



# Enhancement of machinability by workpiece preheating in end milling of Ti-6Al-4V

M.I. Hossain\*, A.K.M. Nurul Amin, A.U. Patwari, A. Karim

Manufacturing and Materials Engineering Department, Faculty of Engineering, International Islamic University Malaysia, Gombak, Kuala Lumpur, Malaysia

\* Corresponding author: E-mail address: i9610093@yahoo.com

Received 22.10.2008; published in revised form 01.12.2008

## Properties

### ABSTRACT

**Purpose:** The main objective of this paper is to investigate the effect of workpiece preheating with high frequency induction heating on improvement of machinability of Ti-6Al-4V during end milling using PVD TiAlN coated inserts. Tool life, cutting force and vibration were investigated during the experiments.

**Design/methodology/approach:** End milling tests were conducted on Vertical Machining Centre (VMC ZPS, Model: MCFV 1060 with quarter immersion cutting. Titanium based alloy Ti-6Al-4V bar was used as the work-piece. Machining was performed with a 20 mm diameter end-mill tool holder (R390-020B20-11M) fitted with one insert. PVD TiAlN coated carbide inserts (R390-11 T3 08E-ML 2030) were used in the experiments. All of the experiments were run at room temperature and preheated conditions. The preheated temperature was maintained at 420°C and no phase change of the workpiece in preheating was ensured from the phase diagram of Ti-6Al-4V. High frequency induction heating was utilized to run the preheated machining.

**Findings:** Preheating helps in substantially increasing tool life and in lowering down the cutting force value, lowering the amplitude of vibration and dynamic forces.

**Practical implications:** The cost of machining Ti-6Al-4V is extremely high because of the relatively low machining speed and short tool life. Therefore, improving the machinability of Ti-6Al-4V is a research topic of much interest, with a number of approaches reported with varied results, such as, cryogenic cutting, high-pressure coolant, rotary-tool, and minimum quantity lubrication (MQL).

**Originality/value:** A new approach of induction preheating to overcome the difficulties in machining of Ti-6Al-4V is presented in this paper. In preheated machining, high frequency induction heating is used as an external heat source to soften the work material surface layer in order to decrease its tensile strength and strain hardening. An experimental study has been performed to assess the effect of workpiece preheating using induction heating system to enhance the machinability of Ti-6Al-4V. The preheating temperature was maintained below the phase change temperature of Ti-6Al-4V.

**Keywords:** Hot machining; Induction heating; Ti-6Al-4V; End-milling; Tool life; Vibration/chatter; Cutting forces

## 1. Introduction

Titanium alloys are widely used in the aerospace industries due to their superior mechanical, chemical and high temperature properties. Titanium alloys are generally used for structural

applications, such as cases and impellers. In fact, they account for 30% of the total engine mass in commercial and 40% in military projects [1]. For these alloys, machining productivity is limited by tool wear which indirectly represents a significant portion of the machining costs as such they are known as difficult-to-cut materials. However, by properly selecting the tool material and

cutting conditions an acceptable rate of tool wear may be achieved and thus lowering the total machining cost [2]. The performance of a cutting tool is normally assessed in terms of its life. Wear criteria are usually used in assessing tool life. Mostly, flank wear is considered, since it largely affects the stability of the cutting wedge and consequently the dimensional tolerance of the machined work surface [3].

Machining of titanium alloys was the subject of interest for many years [4]. Jawaid et al [5] studied the tool wear characteristic in turning titanium alloy Ti-6246. They found that inserts with fine grain size and a honed edge have a longer tool life. At higher cutting speeds the tool failure was due to maximum flank face wear and excessive chipping on the flank edge. Ribeiro et al [6] studied the optimization aspect of titanium alloy Ti-6Al-4V machining. They suggested that the best cutting conditions were close to the suitable conditions for the tool manufacturer. However, it is possible to work in more severe conditions than the manufacturer's conservative conditions.

The use of workpiece preheating (hot machining) as a technique for improving machining operations has been under consideration since the late 19th century. Hot machining is to use an external heat source to soften the work material surface layer in order to decrease its tensile strength and strain hardening [7]. This was informed by understanding that metals tend to deform more easily when heated, thus enhancing machining. The principle behind hot machining is increasing difference in hardness of the cutting tool and workpiece, leading to reduction in the component forces, improved surface finish and longer tool life [8]. Amin and Talantov [9] studied the influence of the furnace method of preheating of workpiece on machinability of titanium alloy BT6 (Russian Standard) and found that all the vertical cutting force component decreases with the increase in the preheating temperature but the radial and the axial components sharply increase to their peak values at a particular temperature. This temperature was termed as the optimum preheating temperature for the investigated titanium alloy. It was observed that the length of chip-tool contact was very small (0.5 mm) compared to that of steels during room temperature machining, but under preheated condition the length of contact increased to 1.0 mm at the optimum temperature. The tool wear rate was also found to be the minimum at this temperature. Expected tool life for an average flank wear of 0.3 mm was calculated for the optimum preheating temperature from the slope of the corresponding curve and was found to be about 3000 sec against 160 sec at room temperature.

Other work has focused on Laser Assisted Machining (LAM) [10] of Inconel 718, reports show that tool wear was decreased by 40%, cutting force was reduced by 18% and metal removal rate was increased by 33% [10]. However, the high costs of high-powered lasers (for example, a 1.5KW CO2 laser costs more than \$150,000) and the large power consumption slowed down the implementation of LAM.

Ozler et al [11] carried out hot-machining operation using austenitic manganese steel as work-piece material using gas flame heating. Leshock et al [12] used numerical and experimental analysis of plasma enhanced machining (PEM) of Inconel 718. They evaluated that peak temperatures must be known so that

thermal damage is prevented or minimized in the workpiece surface. They also found that the ability to predict the temperature distribution is the first step in optimizing thermally enhanced machining.

The main objective of this paper is to investigate the effect of workpiece preheating with high frequency induction heating on improvement of machinability of Ti-6Al-4V during end milling using PVD TiAlN coated inserts. Tool life, cutting force and vibration were investigated during the experiments.

## 2. Experimental details

### 2.1. Workpiece material

The workpiece material used in all experiments was titanium based alloy Ti-6Al-4V with ( $\sigma+\beta$ ) phases. The microstructure of this workpiece is presented in Figure 1. The microstructure consists of both coaxial and columnar alpha phase and intergranular beta phase. The composition of the workpiece (in wt %) is presented in Table 1 and the mechanical properties in Table 2.

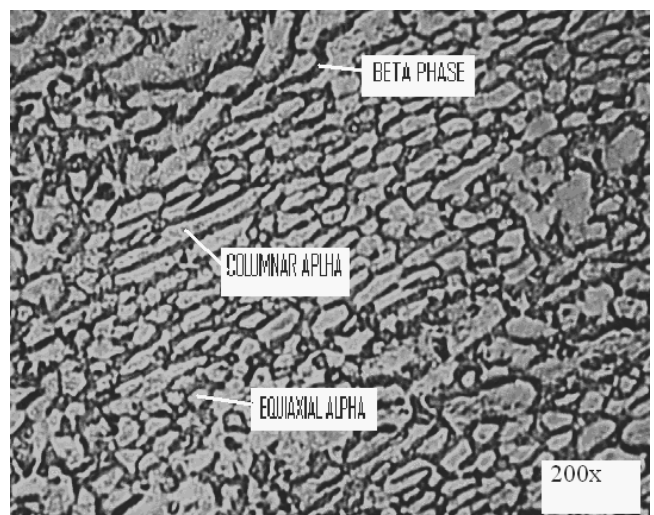

Fig. 1. Microstructure of Ti-6Al-4V with equiaxed and columnar alpha grains (light) with intergranular beta phase (dark); Etchant: 10% HF, 5% HNO<sub>3</sub>, 85% H<sub>2</sub>O

Table 1. Chemical composition of Ti-6Al-4V

Chemical composition of the specimen Ti-6Al-4V in percentage							
H <sub>2</sub>	Al	V	Mo	Fe	C	O <sub>2</sub>	Ti
0.021	5.97	3.8	0.001	0.21	0.06	0.2	Rest

Table 2. The mechanical properties of Titanium Alloy Ti-6Al-4V

Ultimate tensile strength (MPa)	Elongation (%)	Elastic Modulus (GPa)	Hardness (HRC)
897	10	114	36

## 2.2. Cutting tool insert

Sandvick PVD TiAlN coated (4  $\mu\text{m}$  single layer) carbide inserts were used in the experiments. One insert has two cutting edges. The inserts profile and geometry data are presented in Figure 2.

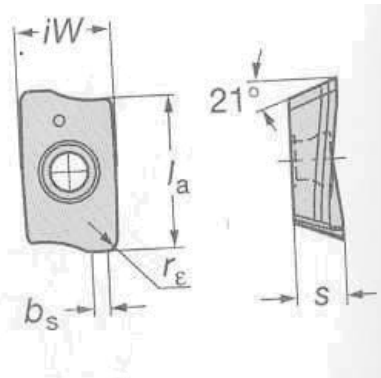

Fig. 2. Tool inserts used for experimentation, PVD TiAlN coated (4 $\mu\text{m}$  single layer) carbide insert. Dimensions, [mm]:  $l_a = 11$ ;  $iW = 6.8$ ;  $s = 3.59$ ;  $b_s = 1.5$ ;  $r_e = 0.8$

## 2.3. Experimental set-up

End milling tests were conducted on Vertical Machining Centre (VMC ZPS, Model: MCFV 1060 with quarter immersion cutting. Titanium based alloy Ti-6Al-4V bar was used as the work-piece. Machining was performed with a 20 mm diameter end-mill tool holder (R390-020B20-11M) fitted with one insert. PVD TiAlN coated carbide inserts (R390-11 T3 08E-ML 2030) were used in the experiments. All of the experiments were run at room temperature and preheated conditions. The preheated temperature was maintained at 420°C and no phase change of the workpiece in preheating was ensured from the phase diagram of Ti-6Al-4V. High frequency induction heating was utilized to run the preheated machining. Selected cutting conditions for the experimentation are presented in Table 3.

Table 3.  
Cutting condition for experimental work

Trial run	Cutting speed, $v$ (m/min)	Feed, $f$ mm/toot $h$	Axial depth of cut, $a_p$ (mm)	Preheated Temperature $\theta$ (°C)
1	80.0	0.07	0.57	420
2	25.0	0.07		
3	256	0.03		
4	80.0	0.16		
5				

The experimental set up for the machining is presented in Figure 3. Depending on the cutting conditions and wear rate, machining was stopped at various interval of cutting length from 100 mm to 200 mm to record the wear of the inserts. Flank wear has been considered as the criteria for tool failure and the wear was measured under a Hisomet II Toolmaker's microscope. Tool

life testing was stopped when an average flank wear achieved exceeded 0.3 mm. Scanning Electron Microscope (SEM) was employed to investigate tool wear and tool morphology. Cutting force and torque measurements were conducted using the Kistler Rotating Cutting Force Dynamometer. Vibration/chatter was monitored and recoded by DASyLab 5.5 software hooked up with National Instrument (NI) Data Acquisition (DAQ) card. Detail experimental set-up of the preheated machining is presented in Figure 3.

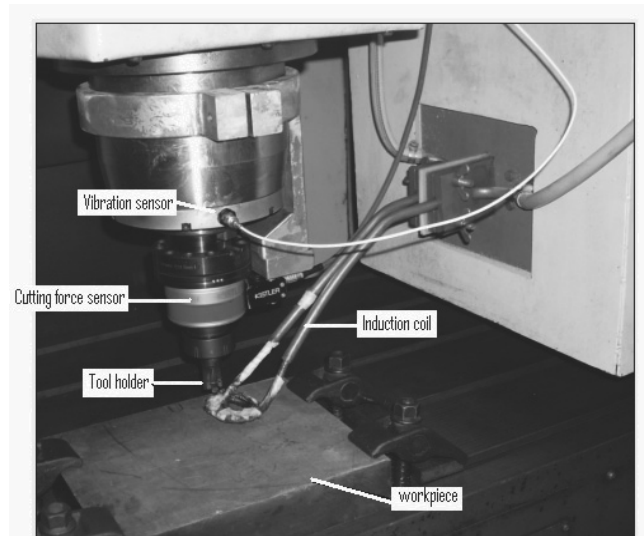

Fig. 3. Experimental set-up

## 3. Results and discussions

### 3.1. Tool life

Fig. 4 shows the tool life (in minute) of PVD TiAlN coated carbide inserts in end milling Ti-6Al-4V both at room temperature and with preheating (420°C). It appears that tool life was significantly influenced by preheating. In all the tool life experiments preheated machining was found superior than the room temperature one with longer tool life. But the advantage of preheating also depends on the cutting conditions i.e. cutting speed and feed as shown in Table 4 and 5. Higher cutting speed gave the better advantage of preheating (Table 4). Lower cutting speeds somewhat suppressed the benefit of preheating. Similarly, highest feed offered the best improvement of tool life by increasing it 80.13% in preheating (Table 5). But reducing feed reduced the preheating benefit and at medium feed the improvement of tool life was only 18.43% (Table 5).

Longer tool life in preheated machining offers an increase of metal removal per tool life. It also offers lesser number of tool changing which in effect increases effective production time. Therefore, the cost of high frequency induction preheating can rightly be justified.

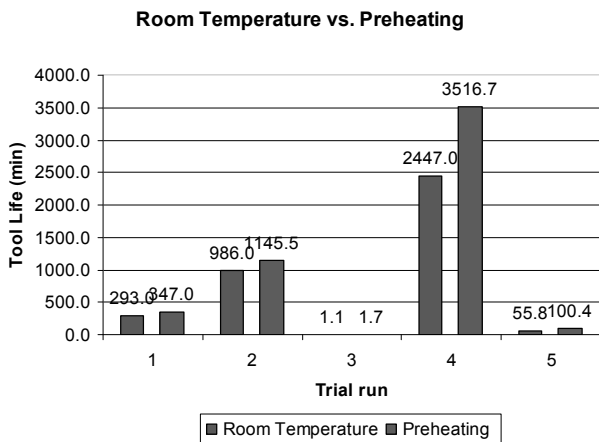

Fig. 4. Comparison between room temperature and preheating in terms of tool life

Table 4. Effect of cutting speed and preheating on tool life

Trial run	Cutting Speed (m/min)	Tool life (room temp) (min)	Tool life (preheating) (min)	Increase in tool life (%)
2	25.0	986.0	1145.5	16.18
1	80.0	293.0	347.0	18.43
3	256.0	1.1	1.7	53.36

Table 5. Effect of feed and preheating on tool life

Trial run	Cutting Speed (m/min)	Tool life (room temp) (min)	Tool life (preheating) (min)	Increase in tool life (%)
4	0.03	2447.0	3516.7	43.71
1	0.07	293.0	347.0	18.43
5	0.16	55.8	100.4	80.13

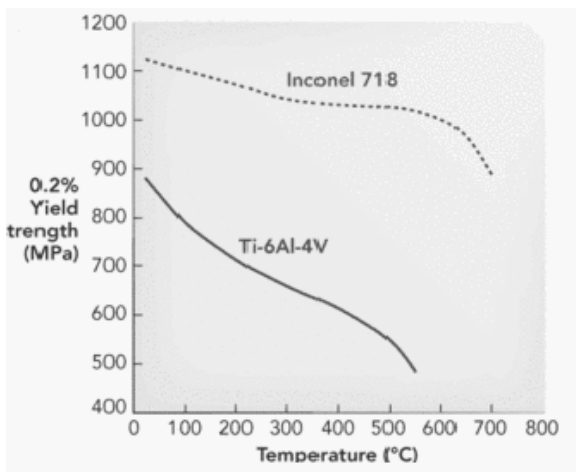

Fig. 5. Yield strength vs. temperature curve for Inconel 718 and Ti-6Al-4V

### Improved Tool Life by Preheating

This very advantage of improved tool life by preheated machining of Ti-6Al-4V might be linked to their yield strength vs. temperature curve as shown in Figure 4.

As found in the Fig. 5, Ti-6Al-4V loses its yield strength rapidly as temperature increases and reaches as minimal as 550 MPa when temperature reaches to 420°C. This plummeting of yield strength at higher temperature gives an upbeat effect on tool wear and eventually enhances tool life.

### 3.2. Cutting forces

Noticeable improvement of tool life was achieved by preheating the workpiece by induction heating in end milling Ti-6Al-4V. This is related to the lowering of cutting force in preheated machining (Fig. 6). The results show that preheating reduces the cutting force in all cutting conditions except at low feed (trial run 4). In trial run 4 preheated machining led to slight increase in the resultant cutting force (Figure 5). But in all other trial runs preheated machining reduced the resultant cutting force by around 10% to 12%. This reduction of resultant cutting force is related to the workpiece softening caused by the preheating. The only exception in trial run 4 where a slight increase of cutting force was reported which may be because of the longer Tool-chip contact length in preheating.

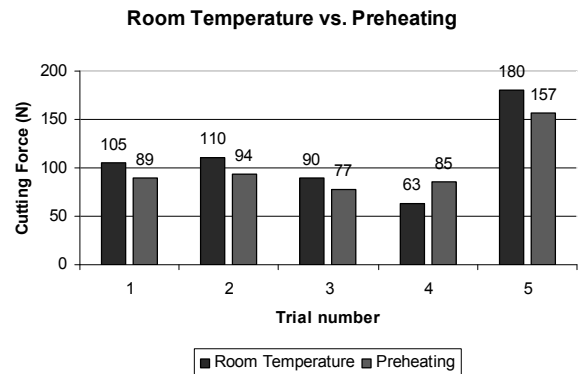
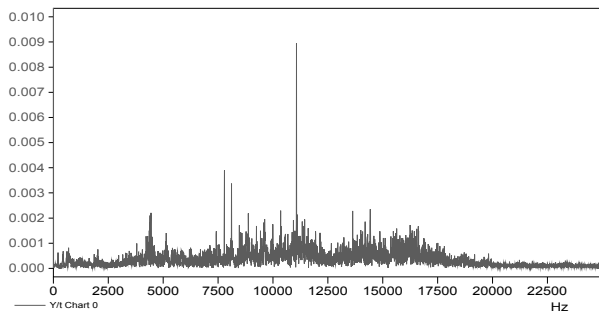

Fig. 6. Comparison between room temperature and preheating in terms of cutting forces

### 3.3. Vibration \ Chatter

Fig. 7 represents the Fast Fourier Transformation (FFT) outputs for room temperature and preheated machining (420°C) for all the 3 different cutting speeds. Fig. 7 presents the effect of preheating in reducing the amplitude of vibration during machining. Significant amount of suppression of chatter was reported during preheated machining of Ti-6Al-4V. It may be observed from Fig. 7 that there were several major peaks in the ranges of 4500 – 5000, 7800-9000, 10500 -11500 Hz. The most significant peak during room temperature cutting was at 4510 Hz with amplitude value of 0.048 mV in trial run 3 (Figure 7(c)(i)). But preheating reduced its amplitude to 0.018 mV (more than 2.6 times) as shown in Figure 7(c)(ii). Preheated machining helped lower the amplitude of machining vibration significantly which can also be found from other vibration results for other cutting speeds in Figure 7(a) (i) and (ii), 7(b) (i) and (ii).



(i) Room temperature condition

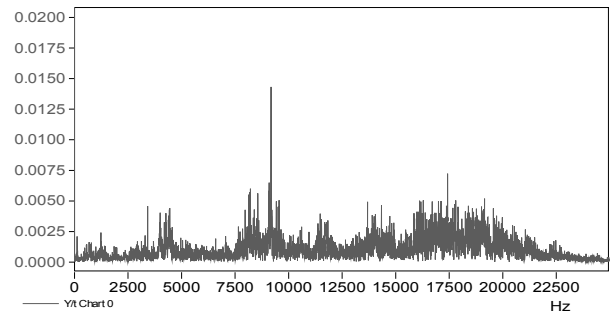

(i) Room temperature condition

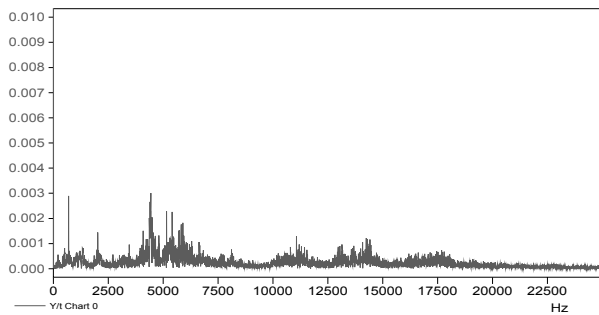

(ii) Preheated condition (420°C)  
(a) Trial run 2, lowest cutting speed (25 m/min)

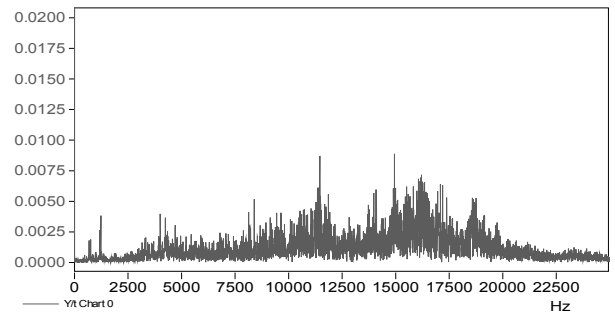

(ii) Preheated condition (420°C)  
(b) Trial run 1, medium cutting speed (80 m/min)

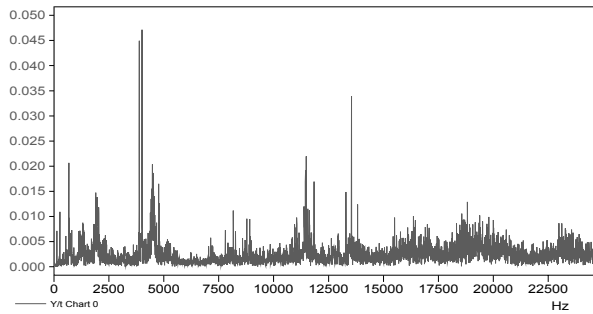

(i) Room temperature condition

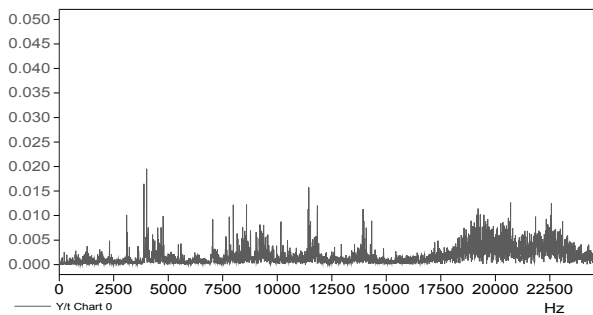

(ii) Preheated condition (420°C)  
(c) Trial run 3, highest cutting speed (256 m/min)

Fig. 7. FFT output of end milling Ti-6Al-4V at various cutting speeds for both room temperature and preheated machining

It is affirmed from above analysis that preheating leads to a reduction in amplitude of vibration and cutting force during cutting. Lower vibration and cutting force will reduce the dynamic loads on the edge which leads to lower tool wear. Softer workpiece reduces the stress acting on the tool, and it has responsible for reducing tool wear and increasing the tool life.

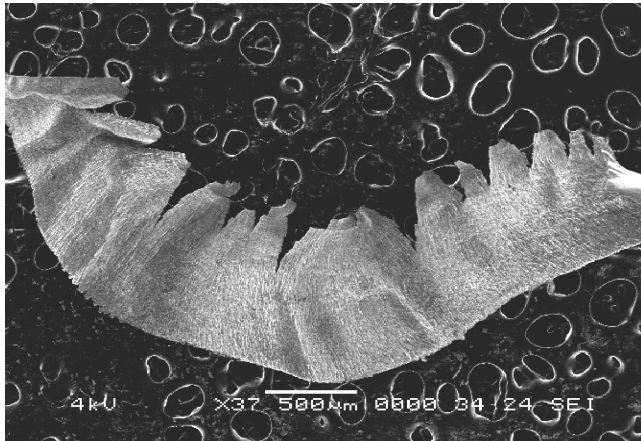

(a) Room temperature condition

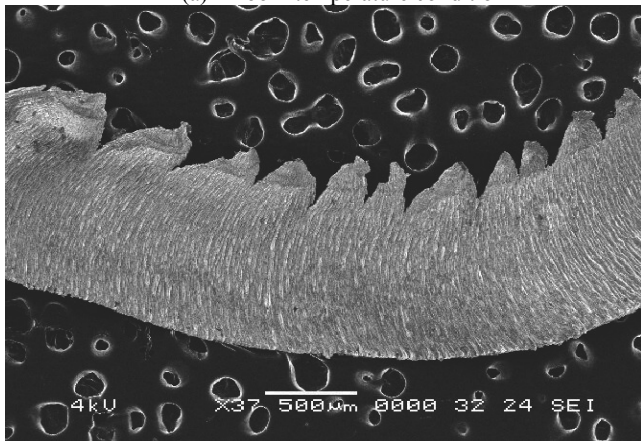

(b) Preheated condition (420 °C)

Fig. 5. SEM photos of the chips for the trial run 1

**Chatter Suppression by Preheating:** To understand the reasons of chatter suppression by preheated machining, the sources or causes of chatter should be identified first. Talantov and Amin [9] have established that chatter arising during turning is a result of resonance, caused by mutual interaction of the vibrations due to the formation of serrated elements of the chip and the natural vibrations of the system components, e.g. the spindle and the tool holder. It may be mentioned here that the frequencies of instability of the chip formation process depends on the work and tool materials and condition of cut. Generally thin chips have the inherent tendency of formation of primary and secondary serrated teeth. It was experimentally found by Amin and Talantov [9] that when the frequency of this teeth serration coincides with any one of the natural frequencies of the system or their lower or higher harmonics, chatter arises in the system. In other words, such a

coincidence results in resonance which is known as chatter. So the type of chip with its typical secondary and some times primary serration leads to the generation of chatter in the machine-tool-fixture-work system.

Chips formed during machining in room temperature conditions are quite thick and strong, with unstable secondary chip serration at the free edge of the chip. This phenomenon can be more clearly observed in the enlarged SEM micrographs of the chips as shown in Fig. 5. Such disintegration of chips in room temperature conditions is not observed in preheated machining. The chips formed during preheated machining are more stable but marks of primary and secondary serrated or saw teeth can be observed in them. In preheated machining the chips seem to be more elongated and thinner than those produced during room temperature machining and hence the cutting forces and stresses applied on the tool are supposed to be lower than those during normal machining. This plays a favourable role in lowering chatter amplitudes and tool wear.

#### 4. Conclusions

The following specific conclusions have been drawn on the work:

- High frequency induction heating was proved as a suitable technique for preheated machining.
- Preheating helps in substantially increasing tool life during end milling Ti-6Al-4V using PVD TiAlN coated carbide inserts. Experimental trial run 5 with high feed gave benefit in increasing tool life by 80.13% in preheating (at 420 °C) compared to the room temperature one
- Preheating helps in lowering down the cutting force values significantly during cutting and reducing acceleration amplitude of vibration. Experiment with preheating at 420 °C can significantly reduce the magnitude of cutting force and acceleration amplitude of vibration and the maximum reductions were reported as 12 % and 300%, respectively.
- Preheated machining lower dynamic forces due to the continuous plastic deformation during chip formation, leading to reduction of chatter.
- Compared to conventional machining, preheated machining has lower hardness near the machined surface due to the lower shear deformation.
- Extensive strain hardening has occurred during machining Ti-6Al-4V, especially at room temperature conditions. Workpiece preheating could substantially reduce the effect of strain hardening.

#### Acknowledgements

The authors wish to thank Ministry of Science, Technology and Innovation (MOSTI) Malaysia for their financial support to the above project through the e-Science Fund Project (Project No.03-01-08-SF0001). And the Research Management Centre IIUM for overall management of the project.

## References

- [1] Y. Honnarat, Issues and breakthrough in the manufacture of turbo-engine titanium parts, *Material Science Engineering A213* (1996) 115-123.
- [2] H.A. Kishawya, C.E. Bece, D.G. McIntosh, Tool performance and attainable surface quality during the machining of aerospace alloys using self-propelled rotary tools, *Journal of Materials Processing Technology* 152 (2004) 266-271.
- [3] E.O. Ezugwu, Z.M. Wang, Titanium alloy and their machinability – a review, *Journal of Materials Processing Technology* 68 (1997) 262-274.
- [4] E.O. Ezugwu, J. Bonney, Y. Yamane, An overview of the machinability of aeroengine alloys, *Journal of Materials Processing Technology* 134 (2003) 233-253.
- [5] Jawaid, C.H. Che-Haron, A. Abdullah, Tool wear characteristics in turning of titanium alloy Ti-6246, *Journal of Materials Processing Technology* 92-93 (1999) 329-334.
- [6] M.V. Ribeiro, M.R.V. Moreira, J.R. Ferreira, Optimization of titanium alloy (6Al-4V) machining, *Journal of Materials Processing Technology* 143-144 (2003) 458-463.
- [7] W. Pentland, C. Mehl, J. Wennberg, Hot machining, *American Machinist/Metalworking Manufacturing* 1 (1960) 117-132.
- [8] E.J. Krabacher, M.E. Merchant, Basic factors in hot machining of metals, *Trans ASME* 73 (1951).
- [9] A.K.M.N. Amin, N.V. Talantov, Influence of the Instability of Chip Formation and Preheating of Work on Tool Life in Machining High temperature Resistance steel and Titanium alloy, *Mechanical Eng. Res. Bull.* 9 (1986) 52-62.
- [10] S.M. Copley, Laser applications, *Handbook of the High Speed Machining Technology*, chapter 16, Chapman and Hall, Dordrecht, Netherlands, 1985.
- [11] L. Ozler, A. Inan, C. Ozel, Theoretical and experimental determination of tool life in hot machining of austenitic manganese steel, *International Journal of Machine Tools and Manufacture* 41 (2000) 163-172.
- [12] C.E. Leshock, J.-N. Kim, Y.C. Shin, Plasma enhanced machining of Inconel 718: modeling of workpiece temperature with plasma heating and experimental results, *International Journal of Machine Tools and Manufacture* 41 (2001) 877-897.