

Tagungsbeitrag zu:
DBG Jahrestagung 2009, Kommission IV
Titel der Tagung:
Böden eine endliche Ressource
DBG, Bonn, 5 – 13. September 2009
Berichte der DBG
(nicht begutachtete online Publikation)

Development of a method for in situ measurement of denitrification in aquifers using ^{15}N tracer tests and membrane inlet mass spectrometry

W. Eschenbach^{1*}, R. Well², H. Flessa²,
W. Walther³ & W.-H.M. Duijnsveld⁴

Summary

We present a new approach for in situ-measurement of denitrification using a combination of ^{15}N -tracer push-pull experiments with in situ analysis of ^{15}N -labeled N_2 and N_2O using membrane inlet mass spectrometry (MIMS).

In the ^{15}N -tracer experiment we present here we supplemented Aquifer material of two depths with ^{15}N labeled nitrate.

The results of our laboratory ^{15}N -tracer test showed a linear increase of denitrification products ($^{15}(\text{N}_2\text{O}+\text{N}_2)$) over time. At the end of our experiment we measured up to 1500 and 3700 $\mu\text{g/L}$ $^{15}(\text{N}_2\text{O}+\text{N}_2)$ in the water samples from the supplemented aquifer material. The online measurement with MIMS enabled us to see during the experiment if and when the production of the labeled denitrification products started.

We took also parallel samples for isotope ratio mass spectrometry (IRMS) analysis to check our MIMS measurements. The measured $^{15}(\text{N}_2\text{O}+\text{N}_2)$ values for IRMS matches the MIMS measurements very well.

¹Soil Science of Temperate and Boreal Ecosystems, Bünsen-Institute University of Göttingen, ²Johann-Heinrich von Thünen-Institute, Institute of Agricultural Climate Research, Braunschweig, ³Formerly with Institute for Groundwater Management, Dresden University of Technology, ⁴Federal Institute for Geosciences and Natural Resources, Hannover,

With the MIMS-method there is no need for sample preparation and so we were able to run the MIMS part of the ^{15}N -tracer test automatically. Later-on this approach will be used in the field.

Key words

^{15}N -tracer experiment, denitrification, denitrification rates, MIMS

Introduction and motivation

Increasing nitrate contamination of groundwater is a problem which has long been recognized but is still a point of permanent concern. One crucial question of nitrate contamination asks how long affected aquifers are able to reduce nitrate before it can reach deeper aquifer zones or surface waters after aquifer passage. This question is especially important for water works and is one of the main topics of our research.

In NO_3^- contaminated aquifers containing reduced compounds like organic carbon or sulfides, denitrification is an intense process. Its characterization is of interest because NO_3^- consumption improves water quality and N_2O production can cause emission of this greenhouse gas to the atmosphere. Spatial distribution of N_2O and N_2 produced by denitrification in groundwater (excess N_2) reflects the NO_3^- input as well as cumulative denitrification during aquifer passage. The amount and spatial distribution of reduced compounds within denitrifying aquifers is not well known. Recent findings from parallel investigations on in situ denitrification and reactive compounds suggests that single-well ^{15}N tracer tests might be a suitable method to characterize the stock of reduced compounds in aquifers (Konrad 2008). Therefore, we want to get an estimation of the long term denitrification capacity of aquifers by single-well ^{15}N tracer tests and the parallel characterization of the reactive compounds of corresponding aquifer material.

Our Motivation behind the experiment presented here was to simplify the instrumental requirements for the analysis of ^{15}N -tracer tests and to make online measurement in the field possible.

Objectives

The overall objective of our studies is to measure the spatial dynamics of denitrification within two sandy aquifers in northern Germany. This includes in situ ^{15}N -tracer push-pull experiments with the analysis of the labeled denitrification products.

The objective for this laboratory ^{15}N -tracer experiment was to develop a new approach for in situ-measurement of denitrification at monitoring wells using a combination of ^{15}N -tracer push-pull experiments with in situ analysis of ^{15}N -labeled N_2 and N_2O using membrane inlet mass spectrometry (MIMS).

Study site and Experimental design

The aquifer material, we used for the ^{15}N -tracer experiment, was taken from two different depths of the Fuhrberger Feld aquifer (Fig 1). One part of the material was taken from 3 m depths from the zone of predominantly heterotrophic denitrification and the other aquifer material originated from 7 m depth, a zone of predominantly autotrophic denitrification in the Fuhrberger Feld Aquifer (Fig 2).

The sediment was then supplemented with ^{15}N -nitrate solution (10 mg $^{15}\text{N}/\text{L}$). Three mesocosms from each depth were filled with 15 L aquifer material, filter units were installed within the mesocosms and were connected via tygon tubings to the automated sampling device (Fig 3).

The sample solution was pumped to the sampling unit for 7 days. The sampling unit consisted of a set of automatically controlled magnetic valves. One small part of the sample was led to the membrane inlet and the other part was collected in glass vials for later IRMS analysis.

The sampling for the MIMS measurement system was carried out automatically.

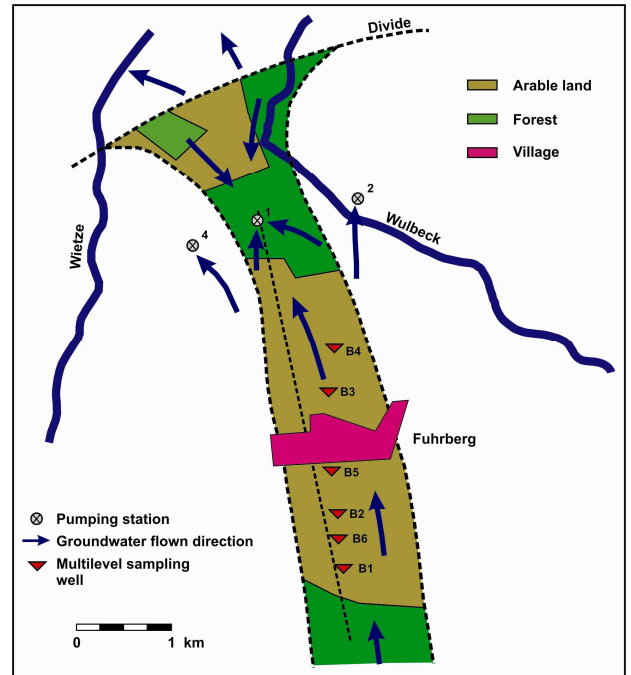

Fig. 1: The Fuhrberger Feld water catchment area (Northwest Germany) with main groundwater flow-line and land use.

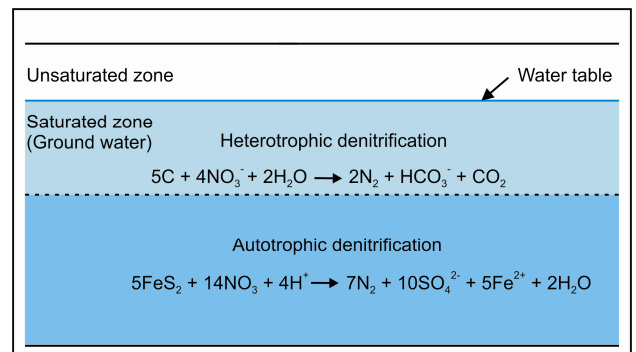

Fig. 1b: The two denitrification zones within the Fuhrberger Feld Aquifer

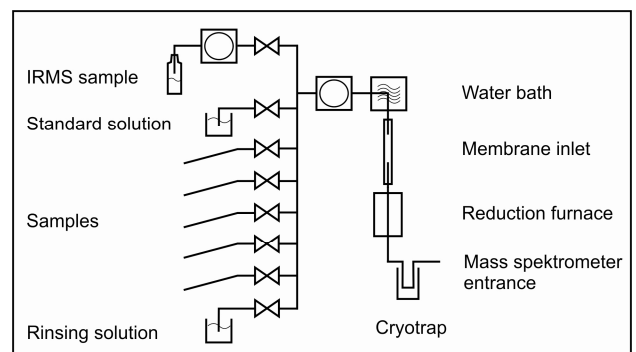

Fig. 3: Schematic figure of the MIMS measuring system (automated sampling device and MIMS).

Results

The results of our measurements showed that the common IRMS technique and the automated MIMS measurement measured the same concentrations of labeled denitrification products ($^{15}\text{N}_2+\text{N}_2\text{O}$) (Fig 4). So it is possible to automate ^{15}N -tracer experiments with MIMS.

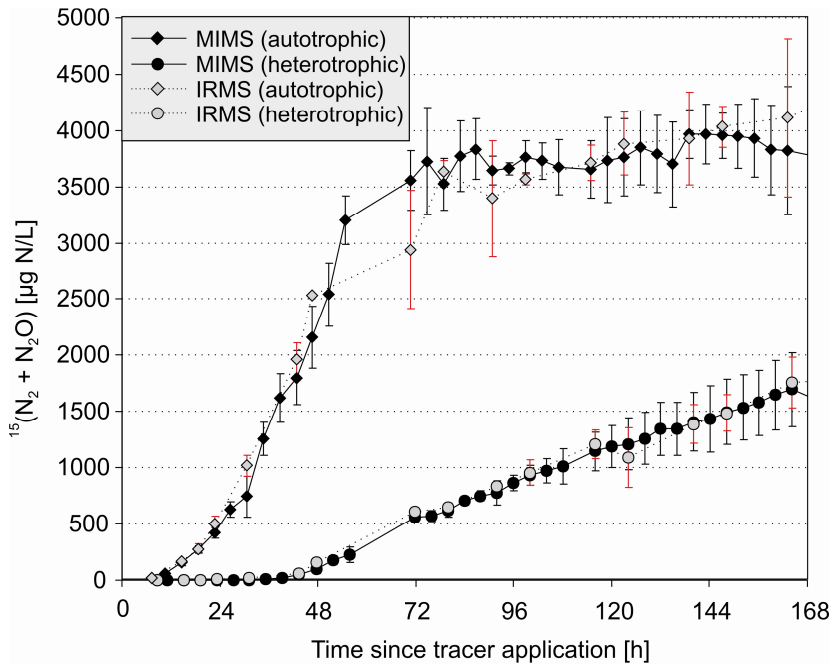

Fig. 4: $^{15}\text{N}_2 + \text{N}_2\text{O}$ values measured with the automated sampling device and MIMS in comparison with the IRMS technique.

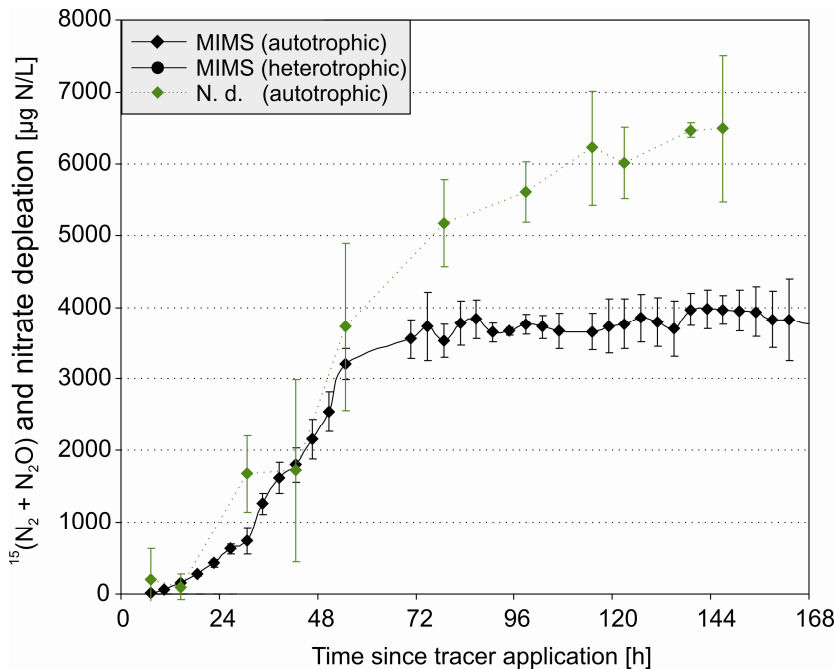

Fig. 5: $^{15}\text{N}_2 + \text{N}_2\text{O}$ values measured with MIMS in comparison with continuous flow measurement of nitrate. (Nitrate depletion = N. d.)

is no need for the laborious sample preparation needed for IRMS measurements.

Figure 4 shows the increase of the measured labeled denitrification products ($^{15}\text{N}_2+\text{N}_2\text{O}$) during the experiment for the material of both denitrification zones of the Fuhrberger Feld Aquifer. The two denitrification zones are clearly distinguishable. The autotrophic denitrification zone showed no lag phase before the production of denitrification products started whereas the mesocosms with aquifer material from the heterotrophic denitrification zone showed a lag phase of 35 hours until a significant production of $^{15}\text{N}_2+\text{N}_2\text{O}$ started.

At the end of our experiment we measured up to 1500 and 3700 $\mu\text{g/L}$ $^{15}\text{N}_2+\text{N}_2\text{O}$ in the water samples from the supplemented aquifer material.

For the autotrophic denitrification zone the measured values of $^{15}\text{N}_2+\text{N}_2\text{O}$ matches the amount of nitrate depletion for the first 55 hours. After 55 hours the $^{15}\text{N}_2+\text{N}_2\text{O}$ values are lower than the nitrate depletion values due to degassing within the aquifer material in the mesocosms.

From this experiment we derived denitrification rates for the heterotrophic material and the autotrophic material which were 310 and 2047 $\text{mg NO}_3^- \text{L}^{-1}\text{yr}^{-1}$ respectively.

Conclusions

With the MIMS system it is possible to automate ^{15}N -tracer experiments in the lab. We expect that this will also be possible in the field. The $^{15}\text{N}_2+\text{N}_2\text{O}$ concentrations

With the MIMS technique it is possible to measure the sample directly and so there

measured with our MIMS system matches the concentrations obtained with common IRMS technique.

Both denitrification zones showed an approximate linear increase of $^{15}(\text{N}_2+\text{N}_2\text{O})$ concentrations at the beginning of the experiment. In the lab test the aquifer material from the two denitrification zones were distinguishable from the steepness of the initial increase of the produced denitrification products. So such ^{15}N -tracer experiments might be a useful tool for the estimation of the denitrification potential of the tested aquifer materials.

Acknowledgements

We thank the deutsche Bundesstiftung Umwelt (DBU) for financial support. Furthermore we want to thank Ingrid Ostermeyer, Karin Schmidt for sample preparation and analysis as well as the Centre for Stable Isotope Research and Analysis (Lars Swzec and Reinhard Langel) and Dr. Michael Brudel for technical support and helpful discussions.

References

- Konrad, C. (2008): Methoden zur Bestimmung des Umsatzes von Stickstoff, dargestellt für drei Pleistozäne Grundwasserleiter Norddeutschlands, PhD thesis, Dresden Univ. of Techn., Germany, 157 pp.
- Well, R. and Myrold, D. D. (1999): Laboratory evaluation of a new method for in situ measurement of denitrification in water-saturated soils, *Soil Biol. Biochem.*, 31, 1109–1119.
- Well, R., Augustin, J., Meyer, K., and Myrold, D.D. (2003): Comparison of field and laboratory measurement of denitrification and N_2O production in the saturated zone of hydromorphic soils, *Soil Biol. Biochem.*, 35, 783–799.