

Manner Assimilation in Korean*

Gyung-Ran Kim

1. Introduction

This study is to show that compared with rule-based analyses, a constraint-based analysis in Optimality Theory presents a better account of manner assimilation in Korean and that Sonority Contact Law operating in the intersyllabic consonants plays a key role in explaining as well as in describing the phenomenon. As typical in the Optimality-theoretic approaches, this study presents another case where the phenomenon under consideration is the result of an appropriate interweaving of the faithfulness and markedness constraints.

Although there has not been any explicit agreement on the definition of sonority, it has been well known that sonority is indispensable to syllabification of a string of segments. The most general cross-linguistic pattern in syllabification is provided by Sonority Sequencing Principle (Jespersen 1904). It requires onsets to rise in sonority toward the nucleus and codas to fall in sonority from the nucleus. Many different scales of sonority have been proposed and the simplest sonority scale for nonsyllabic segments in (1) is suggested by Clements(1990), arranged from least sonorous to most sonorous:

(1) sonority scale

$O < N < L < G$

(O: obstruents, N: nasals, L: liquids, G: glides)

* This paper was presented at the 34th annual linguistic conference at Seoul National University. I would like to thank the audience and two anonymous reviewers for their valuable comments. Of course, all faults and mistakes are mine.

Here obstruents comprise both stops and fricatives. However, these two are treated separately in Jespersen(1904) and Selkirk(1984) among others. In Jespersen voiceless obstruents are less sonorous than the voiced counterparts, while in Selkirk stops rank lower than fricatives and voiceless segments are less sonorous than the voiced counterparts in each group. For this study the sonority scale in (1) is adopted. The following (2) shows the consonant inventory of Korean, where C stands for plain, C' for tense, and C^h for aspirated consonant:

(2) Korean Consonant Inventory

	Labial	Coronal	Dorsal	Glottal
stops	p, p', p ^h	t, t', t ^h	k, k', k ^h	
affricates		c, c', c ^h		
fricatives		s, s'		h
nasals	m	n	ŋ	
liquid		l		

Here coronals include both alveolars /t, t', t^h, s, s', n, l/ and palatals /c, c', c^h/.

As for the syllable in Korean, the maximum size is CVC, where both the onset and coda can be optional: (C)V(C). When a coda is followed by an onset in a sequence of two syllables (C)VC.CV(C), two major assimilations can occur: one is place assimilation and the other manner assimilation. Our concern here is with manner assimilation, whereby, in terms of standard generative phonology, adjacent consonants become similar in the manner features.

Depending on scholars, features assumed to belong to the manner features have been various. For instance in Clements(1985: 248) [nasal], [continuant], and [strident] are dependents of the manner tier. Sagey(1986) puts [nasal] under the soft palate node, with [lateral], [continuant], and [strident] dominated directly by the root node. In McCarthy(1988) the root node directly dominates [nasal] and [continuant], while in Halle(1995), as far as the manner features are concerned, the feature geometry of them is almost the same as that in Sagey. On the other hand Dinnsen(1998) includes [approximant] as well as [nasal] and [continuant] in the manner features. For our discussion of manner assimilation in rule-based accounts, we follow Kim(1987 : 123) and Spencer(1996 : 156) in treating features such as [nasal],

[continuant], and [lateral] as the manner features.

Although we follow the general practice of Korean phonology, the matter of which features belong to the manner features is not critically important here. For our discussion in section 3 is centered around the difference in sonority between a coda and the following onset, where the latter must not rank higher on the sonority scale than the former. This is defined as the Sonority Contact Law Constraint (Murray/Vennemann 1983, Clements 1990, Vennemann 1988, Bat-El 1996):

(3) Sonority Contact Law (Morelli 1999 : 171)

A coda must not be lower in sonority than the following onset.

The principle working behind this law is related with the fact that the sonority slope between the syllable nucleus and the following coda should be slightly slanted, while that between the onset and the following nucleus should be steep (Sonority Dispersion Principle, Clements 1990).

This paper is organized as follows. In section 2, after the introduction of relevant data rule-based accounts using a serial derivation are reviewed and found to be unsatisfactory in explaining manner assimilation in Korean. A constraint-based analysis is given in section 3, where the markedness constraints reflecting Sonority Contact Law are shown to handle the phenomenon more generally and adequately by overcoming the weaknesses of the previous rule-based accounts. The conclusion of the paper is given in section 4.

2. Previous Accounts

Let us take a look at some data relevant to our discussion, where the dot stands for the syllable boundary.

(4) a. obstruent nasalization: $O + N \rightarrow N + N^1$

/pɑpmul/ → [pɑm.mul] 'water used in cooking rice'

/ap^hnal/ → [ɑm.nal] 'future'

/nat^hmal/ → [nɑn.mal] 'word'

¹As in many other languages, the velar nasal [ŋ] is not allowed in the onset position in Korean.

/kas'ni/ → [kan.ni] 'Did you/he/she/they go?'
 /cæni/ → [cæn.ni] 'milk teeth'
 /k'oc^hmal/ → [k'on.mal] or [k'om.mal] 'flower language'
 /kukmin/ → [kuŋ.min] 'nation'

b. /l/-nasalization:

i. O + L → N + N

/kuklan/ → [kuŋ.nan] 'national crisis'
 /pæplyul/ → [pæm.nyul] 'law'

ii. noncoronal N + L → N + N

/kamlo/ → [kam.no] 'sweet dew'
 /kuŋli/ → [kuŋ.ni] 'pondering'

c. /n/-lateralization:

i. /n/ + L → L + L

/konlan/ → [kol.lan] 'difficulty, uneasiness'
 /cunlyəŋ/ → [cul.lyəŋ] 'a high rugged pass'

ii. L + /n/ → L + L

/talnala/ → [tal.la.ra]² 'moon land'
 /mulnoli/ → [mul.lo.ri] 'play in the water'

Traditionally the change in (4a) has been called *obstruent nasalization*, whereby obstruents become nasalized when followed by nasals. (4b) is the case where an onset /l/ becomes [n], which in turn nasalizes the preceding coda obstruent in (4b i). When adjacent to lateral /l/, the coronal nasal /n/ changes into a lateral leading to a sequence of [ll] in (4c).

Now we are going to see how the accounts using rules in a serial derivation describe these phenomena. Prior to the application of nasalization in (4a), coda obstruents are neutralized. That is, continuant, aspirated, and tense obstruents become homorganic plain stops: /p, p', p^h/ → [p], /t, t', t^h, s, s', c, c', c^h/ → [t], and /k, k', k^h/ → [k].³ Neutralization rule in standard generative phonology is formulated as changing the value of [+continuant], [+spread glottis], and [+constricted glottis] of the coda obstruents into the opposite. Then these plain stops become nasalized when followed by nasal segments via a rule in (5) (Kim-Renaud, 1974 : 220). Some examples in (4a) are illustrated in (6).

² In Korean /l/ is realized as [r] between vowels.

³ As pointed out by one reviewer, /h/ is also neutralized to [t] in the coda.

(5) Nasalization

[-continuant] → [+nasal] / ___ [+nasal]

(6)	/ap ^h nal/	/kas'ni/	/kukmin/
syllabification	ap ^h .nal	kas'.ni	kuk.min
neutralization	ap.nal	kat.ni	_____
nasalization	am.nal	kan.ni	kuŋ.min
	[am.nal]	[kan.ni]	[kuŋ.min]

While feature changing rules ordered serially describe the process of nasalization, they do not explain why obstruents undergo nasalization, not the other way around. That is, there is no explanation as to why nasals don't undergo denasalization, resulting in homorganic obstruents.

To the above question, Kim(1987) provides an answer, using the framework of feature geometry combined with underspecification. In this framework, assimilation is regarded as a process in which the marked feature spreads to the underspecified node. Taking /ap^h.nal/ → [am.nal] as an example, the derivation is illustrated below (Kim 1987 : 165):

(7) /ap^h.nal/ 'future'

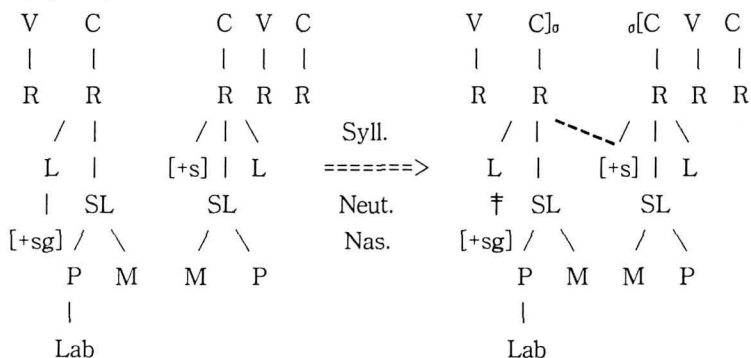

(R: root node, L: laryngeal node, SL: supralaryngeal node, P: place node, M: manner node, [+s]: [+sonorant], Lab: labial, [+sg]: [+spread glottis])

After syllabification, neutralization applies, delinking [+sg] from the laryngeal node. As a result, aspirated bilabial stop /p^h/ changes into plain [p]. Either simultaneously with or after neutralization the marked feature [+sonorant] spreads leftwards to the root node unspecified with the feature [sonorant],

turning the coda [p] into [m] with the application of redundancy rules filling in other underspecified features.

While assimilation as a process of autosegmental feature spreading can explain nasalization in the sequence of O + N, it cannot explain why nasalization does not occur from left to right to the obstruent in a sequence of N + O in (8):

- (8) N + O → N + O, *N + N
 /kamtok/ → [kam.dok], *[kam.nok] 'supervision'
 /kamsu/ → [kam.su], *[kam.nu] 'reduction in product'
 /sinpal/ → [sim.bal], *[sim.mal] 'shoe'

If the marked feature [+sonorant] of nasals spreads to the unmarked position of obstruents, in principle it could also spread rightwards to the following obstruent. In a nutshell, the question is why nasalization occurs only from right to left, not from left to right? Neither feature changing rules nor autosegmental spreading rules can solve this problem.

As for /l/-nasalization in (4b), standard generative phonology describes the process as (9), where /l/ becomes nasal in the onset position:

- (9) /l/-nasalization
 [+lateral] → [+nasal, -cont] / o[___

On the other hand, Kim(1987: 152) describes the process as the delinking of the marked feature [+continuant] from the manner node.

- (10) /l/-nasalization
- | | | |
|-----------|-----|-----------|
| o[C | | o[C |
| | | |
| R | ==> | R |
| / \ | | / \ |
| L [+s] SL | | L [+s] SL |
| / \ | | / \ |
| M P | | M P |
| | | ‡ |
| [+cont] | | [+cont] |

When [+continuant] is delinked from the manner node, the configuration on the right is exactly the same as that of coronal nasal [n]. As in nasalization of (4a), this coronal nasal changes the preceding obstruent into nasal in (4b i). Both feature changing and delinking of autosegment rules can be said to describe /l/-nasalization.

Let us turn to the case of /n/-lateralization in (4c). In standard phonology, this process can be formulated as a mirror image rule:

(11) /n/-lateralization

[+nas, +ant, +cor] → [+lateral, +cont] % [+lateral]

Asking why only the coronal nasal undergoes lateralization, instead of the lateral undergoing nasalization in this environment, Kim(1987) gives the answer in the same way as in the case of (4a). Since the lateral is marked with [+continuant] under the manner node, it is marked compared with the coronal nasal, which is unmarked as far as the continuant feature is concerned. In consequence, it is natural that /n/ become lateralized via spreading of [+continuant] from /l/, not vice versa (Kim 1987 : 149).

(12) /n/-lateralization as [+continuant] spreading (mirror image)

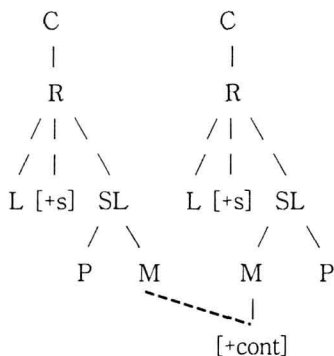

However, in addition to the fact that the serial derivation of feature changing rules and autosegment spreading rules cannot explain the unilateral direction of nasalization from right to left, it has another weakness of treating obstruent nasalization, /l/-nasalization, and /n/-lateralization as separate processes, thus losing generality in explanation as well as in description. We are going to see that these weaknesses can be overcome with an analysis couched in the constraint-based Optimality Theory.

3. A Constraint-Based Account

In this section we are to find that the ranked constraints of Optimality Theory (Prince/Smolensky 1993) or its variant Correspondence Theory (McCarthy/Prince 1995) can solve the problems of directionality and generality in the traditional rule-based accounts. In the now familiar theoretical framework of OT individual grammars result from the ranking of a universal set of constraints, which are violable. There is no derivation in the sense of standard phonology and consequently there are no intermediate levels between the input and the output, either. The optimal output form is selected against the ranked constraints, which are of two types: the faithfulness and markedness constraints. The former require that the input and output be identical and the violation of faithfulness leads to differences between the input and the output. The latter are concerned with specific aspects of phonological and morphological properties. The relative ranking of the faithfulness and markedness constraints determines phonological characteristics of individual languages.

Before going directly to the discussion of manner assimilation in OT, let us compare the data in (4) with those in (13), where (8) is repeated in (b):

- (13) a. O + O → O + O
 /patko/ → [pat.k'o] or [pak.k'o]⁴ 'receive and'
 /kask'in/ → [kat.k'in] or [kak.k'in] 'string of a traditional hat'
 /kuksu/ → [kuk.s'u] 'noodle'
 /kakca/ → [kak.c'a] 'individually'
- b. N + O → N + O
 /kamtok/ → [kam.dok] 'supervision'
 /kamsu/ → [kam.su] 'reduction in product'
 /sinpal/ → [sim.bal] 'shoe'
 /kankokhi/ → [kaŋ.go.k^hi] 'earnestly'
 /caŋkap/ → [caŋ.gap] 'glove'
- c. L + O → L + O
 /kaltɪŋ/ → [kal.t'ɪŋ] 'conflict'
 /kyəlkin/ → [kyəl.gin] 'absence at a workplace'

⁴ An obstruent in Korean is tensed when preceded by another obstruent. In standard phonology it is stated as follows: [-son] → [+tense] / [-son] ____.

- /sulsu/ → [sul.s'ʉ] 'tactic'
 /kulcəl/ → [kul.c'əl] 'bend'
 /solcikhi/ → [sol.c'i.k^hi] 'honestly'
 d. L + /m/ → L + [m]⁵
 /silmyəŋ/ → [sil.myəŋ] 'loss of eye-sight'
 /yəlmu/ → [yəl.mu] 'turnip sprout'

It can be noticed that compared with those in (4), all the intersyllabic consonants in (13) retain the same manner features, although there are some change in the place or laryngeal features: Coronals assimilate in place feature to the following consonant in (13a), while voiceless consonants become voiced between voiced segments in (13b). There is no change as far as the manner features such as [nasal], [continuant], and [lateral] are concerned. The most conspicuous difference is that except for the /l/ + /n/ sequence in (4c ii), the sonority scale of the coda is lower than that of the following onset in the intersyllabic consonants in (4): O + N, O + L, and /n/ + L, while it is not the case in (13): O + O, N + O, L + O, and L + /m/. When a coda is not less sonorous than the following onset, there is no manner assimilation as in (13). Thus it can be said that in Korean manner assimilation occurs only when an onset is more sonorous than the preceding coda as in (4).

The sonority difference in the intersyllabic consonants is defined as Syllable Contact Law (Morelli 1999 : 171), repeated from (3):

(14) Syllable Contact Law

A coda must not be lower in sonority than the following onset.

The case of sonority reversal happens when a coda is less sonorous than the following onset, and that of sonority plateau takes place when the level of sonority is the same between a coda and the following onset (Morelli 1999). From the data in (4) and (13) it is noticed that in Korean sonority reversal is not allowed, while sonority plateau can be tolerated. The following constraints take care of both cases:

(15) *Sonority Reversal(SR): Sonority reversals are disallowed.

*Sonority Plateau(SP): Sonority plateaus are disallowed.

⁵ For the data of L + /n/, see (4c ii). The sequence of L + /ŋ/ is not allowed; cf. note 1).

Since sonority reversal is worse than sonority plateau, *SR ranks higher than *SP: *SR » *SP.

With this much in hand, let us go for other faithfulness and markedness constraints. A closer look at (4) reveals that the value of the [sonorant] feature of the onset in the second syllable remains intact although the [continuant] feature may change as in /pəpɹyul/ → [pəm.nyul] 'law' of (4b i). This is captured as a positional faithfulness constraint:

- (16) Ident[son]_{ONSET}: The value of [sonorant] of the onset in the input should be the same as that of the output.

According to Panini's theorem, this constraint ranks higher than the more general counterpart Ident[son], which requires that the value of [sonorant] of the input be the same as that of the output: Ident[son]_{ONSET} » Ident[son].

The first example of sonority reversal in O + N of (4a) is shown below:

- (17) O + N → N + N: /papmul/ → [pam.mul] 'water used for cooking rice'

papmul	*SR	Id[son] _{ONSET}	*SP	Id[son]
pap.mul	*!			
☞ pam.mul			*	*(p→m)
pap.pul		*!	*	*(m→p)

Although the most faithful to the input, the first candidate incurs the violation of the highest constraint *SR and is thus eliminated from consideration. As for *SP, the second and last candidates fare the same. However, an onset faithfulness constraint Id[son]_{ONSET} selects the former as optimal. The reverse ranking between *SP and Id[son]_{ONSET} can lead to the same result. For now let us assume that there is no ranking hierarchy between the two.

The next example of sonority reversal in O + L of (4b i) is the case involving /l/-nasalization in Korean phonology.

(18) O + L → N + N: /pəplyul/ → [pəm.nyul] 'law'

pəplyul	*SR	Id[son] _{ONSET}	*SP	Id[son]
pəp.lyul	*!			
☞ pəm.nyul			*	*(p→m)
pəm.lyul	*!			*(p→m)
pəm.dyul		*		*!(p/l→m/d)
pəp.dyul		*!	*	*(l→d)

The violation of *SR is fatal to the first and third candidates. The second candidate wins over the fourth one, with one less violation of Id[son]. Comparing the optimal one with the last candidate, we can see again that Id[son]_{ONSET} plays an important part in choosing the optimal one, because the two fare exactly the same except for Id[son]_{ONSET}.

Let us turn to the cases of labial and dorsal nasals /m, ŋ/ + L of (4b ii), another sonority reversal case.

(19) /m, ŋ/ + L → [m, ŋ] + N: /kuŋli/ → [kuŋ.ni] 'pondering'

kuŋli	*SR	Id[son] _{ONSET}	*SP	Id[son]
kuŋ.li	*!			
kuŋ.ni			*	
kul.li			*	

With the constraints given so far it is impossible to decide the optimal form, since there is no difference between the second and third candidate in terms of constraint violation. In order for the second one to be optimal, another constraint that favors it is needed. In the third candidate there is a change of place feature in the coda: Coronal instead of Dorsal. The following faithfulness constraint does the job of preventing the change of the place feature:

(20) Ident[P]: Place feature of the input must be the same in the output.

This constraint is temporarily assigned lower than *SP, since place feature can be optionally deleted: /kamki/ → [kam.gi] or [kaŋ.gi] 'flu,' where the latter form has no Labial as its place feature. The ranking order between Ident[P] and Id[son] does not matter. Tableau (19) will be like the

following:

(21) /ŋl/ → [ŋ.n]: /kuŋli/ → [kuŋ.ni] ‘pondering’

kuŋli	*SR	Id[son] _{ONSET}	*SP	Id[son]	Ident[P]
kuŋ.li	*!				
☞ kuŋ.ni			*		
kul.li			*		*!

Both the second and third candidates tie till *SP on the ranking. However, the second candidate wins over the last one, since the latter additionally violates Ident[P] with its place feature Dorsal changed in the output⁶.

By the way, the optimal output has [-continuant] in the onset of the second syllable, and thus it violates Max[cont], which bans the deletion of the input specification of [+continuant]⁷:

(22) Max[cont]: The [+continuant] feature of the input segments must be preserved in the output.

Since the optimal form [kuŋ.ni] violates it, it should be placed lower than Ident[P], the violation of which militates critically against the competing unsuccessful candidate *[kul.li].

Let us move on to /n/-lateralization in (4c i), where the coronal nasal /n/ is followed by the lateral /l/.

⁶ However, as pointed out by Prof. Yangsoo Moon, this tableau cannot explain why the first candidate sounds better than the third one, although both are not optimal.

⁷ Although tangential to our main concern, this constraint can describe the so-called /l/-nasalization in words beginning with lateral /l/, in combination with another constraint banning a lateral in word initial position, *W[l].

(ex) /loin/ → [no.in] ‘old people’

loin	*w[l]	Id[son] _{ONSET}	Max[cont]
lo.in	*!		
☞ no.in			*
to.in		*!	*

(23) /n/ + L → L + L [ll]: /konlan/ → [kol.lan] ‘difficulty’

konlan	*SR	Id[son] _{ONSET}	*SP	Id[son]	Ident[P]	Max[cont]
kon.lan	*!					
^ε kol.lan			*			
kon.nan			*			*!

The violation of the highest constraint *SR eliminates the first candidate. As for the remaining candidates, the decision is left to Max[cont], which rules out the third candidate by virtue of the deletion of [+continuant] in the onset [l]. On the other hand, the second candidate preserves [+continuant] of the input lateral, thus obeying Max[cont] to be optimal⁸.

So far we have seen cases where Sonority Contact Law is violated in the intersyllabic consonant sequence of the input, and manner assimilation takes place to repair the inappropriate situation. The optimal output results from the constraint ranking where sonority-based markedness constraints banning both sonority reversal and sonority plateau are placed higher than the faithfulness constraints.

The following is a manner assimilation conundrum: L + /n/ → [ll] in (4c ii), where the /n/ sequence does not violate Syllable Contact Law with the coda /l/ more sonorous than the following onset /n/, but manner assimilation still occurs. With the constraint ranking in (23), the following tableau is what we get for the /l/ + /n/ sequence. The columns of both Id[son] and Ident[P] are omitted, since they are not critically relevant here. The mark ^ε means that the candidate is calculated as optimal but cannot be the attested form, which is marked with ☹.

(24) L + /n/ → L + L [ll]: /talnala/ → [tal.la.ra] ‘moon land’

talnala	*SR	Id[son] _{ONSET}	*SP	Max[cont]
^ε tal.na.ra				
☹ tal.la.ra			*!	
tan.na.ra			*!	*

⁸ Although one reviewer suggests using Ident[lateral] instead of Max[cont], it cannot distinguish between the second and third candidate: both candidates would violate Ident[lateral] once, with [-lateral] of the input /n/ changing into [+lateral] in the second candidate and [+lateral] of the input /l/ changing into [-lateral] in the third candidate.

The ranking in this tableau selects the wrong candidate as optimal. The attested candidate [tal.la.ra] should win, but does not. For this candidate to win, it is necessary to have a constraint which the first candidate violates, but the second candidate does not. And the constraint in question should rank above *SP. Putting /n/ → [l] in (23) and /l/ → [l] in (24) together, we can notice that both /n/ and /l/ are coronal sonorants, differing only in continuancy. The output sequence of coronal sonorants is always [+cont][+cont], whether the input is either /n/ or /l/. Considering the sequence of [-cont][-cont] of [n.n] in [cæn.ni] ← /cæni/ 'milk teeth' in (4a) or [kan.ni] ← /kanni/ 'permanent teeth', the sequence of coronal sonorants should be either [+cont][+cont] or [-cont][-cont], neither *[+cont][-cont] nor *[-cont][+cont]. Thus the following constraint should be included in the ranking:

- (25) Coronal Sonorant Sequence(CSS): Adjacent coronal sonorants have the same value of [continuant].

Both /n/ and /l/ are coronals and they are made with the tongue tip raised against the alveolar ridge. Being sonorants, they resonate while the pressure inside and outside the vocal track is roughly equal. The unique difference between these two sounds is that /n/ is made with the velum lowered and the air escapes through the nose, while /l/ is pronounced with the velum raised and the air passes alongside of the tongue. When /n/ and /l/ abut each other, to maintain the pressure inside and outside the vocal track equally, it is assumed to be easier to let the air flow continuously or to block it all the while than to interrupt the flow of air from one segment to another.

In addition, the two sounds are perceptually difficult to distinguish and it is articulatorily rather economical to neglect minor perceptual difference, eliminating the movement of the velum. Thus, when /n/ and /l/ are adjacent, a sequence of [ll] results with the velum maintaining its raised position all the while⁹.

With this constraint ranking above *SP, we get the following tableau for the intersyllable sequence of /ln/:

⁹ Thanks to Prof. Jongho Jun(p.c.).

(26) L + /n/ → L + L [ll]: /talnala/ → [tal.la.ra] 'moon land'

talnala	*SR	CSS	Id[son] _{ONSET}	*SP	Max[cont]
tal.na.ra		*!			
☞ tal.la.ra				*	
tan.na.ra				*	*!

Although the most faithful to the rest of constraints, the first candidate incurs fatally the violation of CSS, making optimal the second one, which in turn wins over the last one due to Max[cont]. Going back to (23) with a sequence of [nl], CSS works prominently in selecting the optimal output between the second and the last candidate. The two violate only one constraint each. However, CSS ranks higher than *SP, which makes the second candidate optimal.¹⁰

(23)' /n/ + L → L + L [ll]: /konlan/ → [kol.lan] 'difficulty'

konlan	*SR	CSS	Id[son] _{ONSET}	*SP	Max[cont]
kon.lan	*!	*			
☞ kol.lan				*	
kon.nan				*	*!
kol.nan		*!			

To conclude, manner assimilation in Korean results from the following constraint ranking, where the two sonority-based constraints *SR and *SP are a key to describing and explaining the phenomenon:

(27) *SR » CSS » Id[son]_{ONSET}, *SP » Id[son], Ident[P] » Max[cont]

¹⁰ In passing, the same ranking of the above constraints can be used for the explanation of the phonological change in the so-called Class I prefix in- 'not' in English. When a base begins with the liquid /l/ or /r/, the alveolar nasal /n/ of the prefix undergoes total assimilation to the following liquid: in + regular → irregular and in + legal → illegal.

in + regular	*SR	CSS	Id[son] _{ONSET}	*SP	Max[cont]
inregular	*!	*			
☞ irregular				*	
innregular				*	*!

4. Conclusion

Both feature changing rules and autosegment spreading rules are found to have two problems in terms of explaining and describing manner assimilation in Korean: the first weakness is related with the directionality of assimilation and the second with generality. First of all, the account using feature changing rules does not explain why nasalization, not denasalization, occurs, not to mention the above two problems.

While providing an answer to this question, another rule-based account in the framework of feature geometry and underspecification still cannot provide an explanation as to why manner assimilation occurs from right to left, not from left to right. If the marked features such as [+sonorant], [+continuant], or [+nasal] spread to the node unmarked with the features in question, there is no reason why the same marked features cannot spread from left to right to the node still unmarked with the manner features.

As for the second problem, the above rule-based accounts treat obstruent nasalization, /l/-nasalization, and /n/-lateralization as three separate processes and thus lacks in generality. In short, the two accounts in section 2 fail to explain why manner assimilation occurs as it does.

On the other hand, the analysis in section 3 has shown that manner assimilation is a result of the constraint ranking whereby the sonority-based markedness constraints *SR and *SP play a pivotal role, interwoven with the faithfulness constraints. With these two constraints, a constraint-based analysis can explain as well as describe why and how manner assimilation happens as it does: that is, to observe Sonority Contact Law. It is natural that the direction of assimilation be from right to left, since a coda must not be less sonorous than the following onset. By using the same constraint ranking, the three processes of obstruent nasalization, /n/-lateralization, and /l/-nasalization can be described as one process to repair inappropriate situations of sonority difference between a coda and the following onset consonant.

In conclusion, it can be said that the constraint-based analysis given here can present a better account of manner assimilation in Korean.

References

- Bat-El, O. (1996) 'Selecting the best of the worst,' *Phonology* 13, 283-328.
- Beckman, J. (1998) *Positional Faithfulness*, Doctoral dissertation, University of Massachusetts at Amherst.
- Clements, G. N. (1985) 'The Geometry of Phonological Features,' *Phonology Yearbook* 2, 225-255.
- Clements, G. N. (1990) 'The Role of Sonority Cycle,' in Kingston, J. & M. Beckman eds., *Papers in Laboratory Phonology I: Between the Grammar and Physics of Speech*, Cambridge, Cambridge University Press, 282-333.
- Dinnsen, D. A. (1998) 'On the Organization and Specification of Manner Features,' *Journal of Linguistics* 34, 1-25.
- Halle, M. (1995) 'Feature Geometry and Feature Spreading,' *Linguistic Inquiry* 26, 1-46.
- Jespersen, O. (1904) *Lehrbuch der Phonetick*, Leipzig, Teubner.
- Kenstowicz, M. (1994) *Phonology in Generative Grammar*, Oxford, Blackwell Publishers.
- Kim, K-H. (1987) *The Phonological Representation of Distinctive Features: Korean Consonantal Phonology*, Doctoral dissertation, University of Iowa.
- Kim-Renaud, Y-K. (1974) *Korean Consonantal Phonology*, Doctoral dissertation, University of Hawaii at Manoa.
- Lombardi, L. (1999) 'Positional Faithfulness and Voicing Assimilation in Optimality Theory,' *Natural Language and Linguistic Theory* 17, 267-302.
- McCarthy, J. (1988) 'Feature Geometry and Dependency: A Review,' *Phonetica* 45, 84-108.
- McCarthy, J. and A. Prince. (1993) 'Prosodic Morphology and Templatic Morphology,' *Phonology and Morphology* 12, 49-88.
- McCarthy, J. and A. Prince. (1995) 'Faithfulness and Reduplicative Identity,' in J. Beckman, S. Urbanczyk & L. Walsh, eds., *University of Massachusetts Occasional Papers in Linguistics in Optimality Theory*, GLSA, University of Massachusetts, Amherst, 249-384.
- Morelli F. (1999) *The Phonotactics and Phonology of Obstruents in Optimality Theory*, Doctoral dissertation, University of Maryland at College Park.

- Murray, R. and T. Vennemann. (1983) 'The Syllabic and Morphological Structure in German Phonology,' *Language* 59, 514-528.
- Prince, A. and P. Smolensky. (1993) *Optimality Theory: Constraint Interaction in Generative Grammar*, Rutgers University and University of Colorado ms.
- Sagey, E. (1986) *The Representation of Features and Relations in Nonlinear Phonology*, Doctoral dissertation, MIT, published by Garland Press, New York, 1990.
- Selkirk, E. (1984) 'On the Major Features and Syllable Theory,' in M. Arnoff and R. Oehrle eds., *Language Sound Structure*, Cambridge, Mass., MIT Press.
- Spencer, A. (1996) *Phonology: Theory and Description*, Oxford, Blackwell Publishers.
- Vennemann, T. (1988) *Preference Law for Syllable Structure*, Berlin, Mouton de Gruyter.
- Zec, D. (1995) 'Sonority Constraints on Syllable Structure,' *Phonology* 12, 85-129.

ABSTRACT

Manner Assimilation in Korean

Gyung-Ran Kim

This study is to show that compared with rule-based analyses, a constraint-based analysis in Optimality Theory presents a better account of manner assimilation in Korean and that Sonority Contact Law operating in the intersyllabic consonants plays a key role in explaining as well as in describing the phenomenon.

The account using feature changing rules does not explain why nasalization, not denasalization, occurs, while another account in the framework of feature geometry and underspecification cannot provide an explanation as to why the manner assimilation occurs from right to left, not to left to right. Both accounts show another weakness of lack in generality by treating

obstruent nasalization, /l/-nasalization, and /n/-lateralization as three separate processes.

On the other hand, the present analysis in Optimality Theory overcomes the problems of directionality and generality of the rule-based analyses. Manner assimilation is a result of the constraint ranking in which, interwoven with the faithfulness constraints, the sonority-based markedness constraints *SR and *SP operate to observe Sonority Contact Law. According to the law, a coda must not be less sonorous than the following onset and thus manner assimilation applies from right to left. By using the same constraint hierarchy the three separate processes can be described as one process of repairing the inappropriate situation of sonority difference between a coda and the following onset.

Department of English Education
Yeungnam University
Dae-dong 214-1, Gyeongsan-si
Gyeongbuk 712-749, Korea
E-mail : grkim@yu.ac.kr