

University of Nebraska - Lincoln

DigitalCommons@University of Nebraska - Lincoln

Final Reports & Technical Briefs from Mid-
America Transportation Center

Mid-America Transportation Center

2003

BRIDGE RAILS AND TRANSITIONS FOR PEDESTRIAN PROTECTION

Nicholas R. Hiser

Ronald K. Faller

Dean L. Sicking

John R. Rohde

John D. Reid

See next page for additional authors

Follow this and additional works at: <https://digitalcommons.unl.edu/matcreports>



Part of the [Civil Engineering Commons](#), and the [Transportation Engineering Commons](#)

This Article is brought to you for free and open access by the Mid-America Transportation Center at DigitalCommons@University of Nebraska - Lincoln. It has been accepted for inclusion in Final Reports & Technical Briefs from Mid-America Transportation Center by an authorized administrator of DigitalCommons@University of Nebraska - Lincoln.

Authors

Nicholas R. Hiser, Ronald K. Faller, Dean L. Sicking, John R. Rohde, John D. Reid, and Karla A. Polivka

*Midwest States' Regional Pooled Fund Research Program
Fiscal Year 1999-2000 (Year 10)
Research Project Number SPR-3(017)
NDOR Sponsoring Agency Code RFPF-00-04*

BRIDGE RAILS AND TRANSITIONS FOR PEDESTRIAN PROTECTION

Submitted by

Nicholas R. Hiser, B.S.M.E., E.I.T.
Graduate Research Assistant

Dean L. Sicking, Ph.D., P.E.
Professor and MwRSF Director

John D. Reid, Ph.D.
Associate Professor

Ronald K. Faller, Ph.D., P.E.
Research Assistant Professor

John R. Rohde, Ph.D., P.E.
Associate Professor

Karla A. Polivka, M.S.M.E., E.I.T.
Research Associate Engineer

MIDWEST ROADSIDE SAFETY FACILITY

University of Nebraska-Lincoln
527 Nebraska Hall
Lincoln, Nebraska 68588-0529
(402) 472-6864

Submitted to

MIDWEST STATE'S REGIONAL POOLED FUND PROGRAM

Nebraska Department of Roads
1500 Nebraska Highway 2
Lincoln, Nebraska 68502

MwRSF Research Report No. TRP-03-127-03

February 20, 2003

Technical Report Documentation Page

1. Report No. SPR-3(017)	2.	3. Recipient's Accession No.	
4. Title and Subtitle Bridge Rails and Transitions for Pedestrian Protection		5. Report Date February 20, 2003	
		6.	
7. Author(s) Hiser, N.R., Faller, R.K. Sicking, D.L., Rohde, J.R., Reid, J.D., and Polivka, K.A.		8. Performing Organization Report No. TRP-03-127-03	
9. Performing Organization Name and Address Midwest Roadside Safety Facility (MwRSF) University of Nebraska-Lincoln 527 Nebraska Hall Lincoln, NE 68588-0529		10. Project/Task/Work Unit No.	
		11. Contract © or Grant (G) No. SPR-3(017)	
12. Sponsoring Organization Name and Address Midwest States' Regional Pooled Fund Program Nebraska Department of Roads 1500 Nebraska Highway 2 Lincoln, Nebraska 68502		13. Type of Report and Period Covered Final Report 1999-2003	
		14. Sponsoring Agency Code RFPF-00-04	
15. Supplementary Notes Prepared in cooperation with U.S. Department of Transportation, Federal Highway Administration			
16. Abstract (Limit: 200 words) <p style="margin-left: 40px;">It is desirable to protect pedestrians on bridges from motor vehicles. However, transition problems arise at the ends of bridges where the bridge rail, bridge rail end treatment, and pedestrian walkway compete for the limited available space. The objective of this study was to identify the most common scenarios in which the protection of pedestrians on bridges is desirable, and then to develop bridge rail and bridge rail end treatment configurations to accommodate those situations. The objective was achieved by performing a field investigation, a survey of state transportation agencies, and a literature review. Recommendations for the placement and general design of standard barrier configurations have been provided in the form of thirteen generalized site drawings. The barrier configurations outlined within this report were based on NCHRP Report No. 350 approved hardware, roadside hardware meeting prior safety standards, hardware believed to provide moderate safety, hardware currently under development, and sound engineering judgement. Therefore, the barrier configurations recommended herein are not equivalent in terms of the level of pedestrian safety provided. As a result, sound engineering judgement is required when determining which barrier configuration to implement for providing pedestrian protection on and near the ends of bridges.</p>			
17. Document Analysis/Descriptors Highway Safety, Roadside Safety, Bridge Railing, Approach Guardrail Transition, Longitudinal Barrier, Pedestrian Protection, Bicycle Protection		18. Availability Statement No restrictions. Document available from: National Technical Information Services, Springfield, Virginia 22161	
19. Security Class (this report) Unclassified	20. Security Class (this page) Unclassified	21. No. of Pages 98	22. Price

DISCLAIMER STATEMENT

The contents of this report reflect the views of the authors who are responsible for the facts and the accuracy of the data presented herein. The contents do not necessarily reflect the official views or policies of the State Highway Departments participating in the Midwest States' Regional Pooled Fund Research Program nor the Federal Highway Administration. This report does not constitute a standard, specification, or regulation.

ACKNOWLEDGMENTS

The authors wish to acknowledge several sources that made a contribution to this project: (1) the Midwest States' Regional Pooled Fund Program funded by the Connecticut Department of Transportation, Iowa Department of Transportation, Kansas Department of Transportation, Minnesota Department of Transportation, Missouri Department of Transportation, Montana Department of Transportation, Nebraska Department of Roads, Ohio Department of Transportation, South Dakota Department of Transportation, Texas Department of Transportation, and Wisconsin Department of Transportation for sponsoring this project; and (2) the University of Nebraska-Lincoln for matching support.

A special thanks is also given to the following individuals who made a contribution to the completion of this research project.

Midwest Roadside Safety Facility

R.W. Bielenberg, M.S.M.E., Research Associate Engineer
J.C. Holloway, M.S.C.E., Research Associate Engineer
Undergraduate and Graduate Assistants

Iowa Department of Transportation

David Little, P.E., Assistant District Engineer
Will Stein, Design Methods Engineer

Kansas Department of Transportation

Ronald Seitz, P.E., Assistant Bureau Chief
Rodney Lacy, P.E., Road Design Leader

Missouri Department of Transportation

Daniel Smith, P.E., Research and Development Engineer
David Silvestor, Design Standards Engineer
Tom Allen, Project Development Engineer

Minnesota Department of Transportation

Erik Wolhowe, Structures Research Engineer
Jim Klessig, Implementation Liaison
Mohammad Dehdashti, P.E., Design Standards Engineer
Andrew Halverson, P.E., former Assistant Design Standards Engineer

Nebraska Department of Roads

Phil Tenhulzen, P.E., Design Standards Engineer
Mark Traynowicz, P.E., Assistant Engineer, Construction Division
Amy Starr, Research Engineer
Leona Kolbet, former Research Coordinator

Ohio Department of Transportation

Dean Focke, P.E., Roadway Standards Engineer
Monique Evans, P.E., Administrator

South Dakota Department of Transportation

Bernie Clocksin, Lead Project Engineer

Texas Department of Transportation

Mark Bloschock, P.E., Supervising Design Engineer
Mark Marek, P.E., Design Engineer

Wisconsin Department of Transportation

Beth Cannestra, P.E., Chief Roadway Development Engineer
Peter Amakobe, Standards Development Engineer

Montana Department of Transportation

Susan Sillick, Research Bureau Chief

Connecticut Department of Transportation

Dionysia Oliveira, Transportation Engineer 3

Federal Highway Administration

John Perry, P.E., Nebraska Division Office

TABLE OF CONTENTS

	Page
TECHNICAL REPORT DOCUMENTATION PAGE	i
DISCLAIMER STATEMENT	ii
ACKNOWLEDGMENTS	iii
TABLE OF CONTENTS	v
List of Figures	viii
List of Tables	x
1 INTRODUCTION	1
1.1 Problem Statement	1
1.2 Background	1
1.3 Objective	2
1.4 Scope	2
2 LITERATURE REVIEW	5
2.1 Introduction	5
2.2 Pedestrian and Bicycle Facilities	5
2.2.1 Pathway Guidance	5
2.2.2 Separation Guidance	7
2.3 Bridge Railings	8
2.4 Bridge Railing End Treatments	9
2.5 Curbs	10
2.6 Relevant Approved Hardware	14
2.6.1 Approach Guardrail Transition with Curb	14
2.6.2 W-beam Guardrail Over Curbs	15
2.6.3 Combination Vehicle/Pedestrian and Combination Vehicle/Bicycle Bridge Rails	15
2.6.4 Low-Height Bridge Rails and Barriers	17
3 STATE STANDARDS, PRACTICES, AND SPECIFICATIONS	18
3.1 Introduction	18
3.2 Iowa Department of Transportation	18
3.2.1 Pedestrian and Bicycle Facilities	18
3.2.2 Bridge Railings	18
3.2.3 Bridge Railing End Treatments	18
3.2.4 Curbs	19
3.2.5 Typical Pedestrian Facilities	19

3.3 Kansas Department of Transportation	19
3.3.1 Pedestrian and Bicycle Facilities	19
3.3.2 Bridge Railings	19
3.3.3 Bridge Railing End Treatments	22
3.3.4 Curbs	22
3.4 Missouri Department of Transportation	22
3.4.1 Pedestrian and Bicycle Facilities	22
3.4.2 Bridge Railings	23
3.4.3 Bridge Railing End Treatments	23
3.4.4 Curbs	25
3.5 Minnesota Department of Transportation	25
3.5.1 Pedestrian and Bicycle Facilities	25
3.5.2 Bridge Railings	26
3.5.3 Bridge Railing End Treatments	26
3.5.4 Curbs	26
3.6 South Dakota Department of Transportation	26
3.6.1 Pedestrian and Bicycle Facilities	27
3.6.2 Bridge Railings	27
3.6.3 Bridge Railing End Treatments	27
3.6.4 Curbs	27
3.6.5 Typical Pedestrian Facilities	28
3.7 Texas Department of Transportation	28
3.7.1 Pedestrian and Bicycle Facilities	28
3.7.2 Bridge Railings	32
3.7.3 Bridge Railing End Treatments	33
3.7.4 Curbs	34
4 FIELD INVESTIGATION	35
4.1 Introduction	35
4.2 No Barrier Separation - Unlimited Approach Length	35
4.2.1 Transitions, Guardrails, and Terminals	35
4.3 No Barrier Separation - Limited Approach Length	37
4.3.1 Curbs and Buffer Zones	37
4.4 Barrier Separation Provided - Unlimited Approach Length	37
4.4.1 Crash Cushions	37
4.4.2 Sloped Concrete End Terminal	40
4.4.3 Transitions, Guardrails, and Terminals	40
4.4.4 Transitions, Guardrails, and Crash Cushions	45
4.5 Barrier Separation Provided - Limited Approach Length	49
4.5.1 Sloped Concrete End Terminal	49
4.5.2 Short Radius Guardrail	49

5 BRIDGE RAIL END TREATMENT CONFIGURATIONS	56
5.1 Introduction	56
5.2 No Barrier Separation	57
5.2.1 Curbs, Placebo Barriers, and Buffer Zones	58
5.2.2 Unlimited Approach Length	61
5.2.2.1 Transitions, Guardrails, and Terminals	61
5.2.2.2 Crash Cushions	64
5.2.2.3 Evaluation - No Barrier Separation, Unlimited Approach Length	64
5.2.3 Limited Approach Length	66
5.2.3.1 Crash Cushions	66
5.2.3.2 Short Radius Guardrails	66
5.2.3.3 Evaluation - No Barrier Separation, Limited Approach Length	68
5.3 Barrier Separation Provided	70
5.3.1 Unlimited Approach Length	70
5.3.1.1 Transitions, Guardrails, and Terminals	70
5.3.1.2 Crash Cushions	76
5.3.1.3 Low-Height Barriers	80
5.3.1.4 Evaluation - Barrier Separation Provided, Unlimited Approach Length	83
5.3.2 Limited Approach Length	84
5.3.2.1 Crash Cushions	84
5.3.2.2 Low-Height Barriers	84
5.3.2.3 Short Radius Guardrails	85
5.3.2.4 Evaluation - Barrier Separation Provided, Limited Approach Length	89
 6 SUMMARY AND CONCLUSIONS	 92
 7 RECOMMENDATIONS	 94
 8 REFERENCES	 96

List of Figures

	Page
1. Vehicle Bumper Trajectory Illustration	13
2. Typical Pedestrian Facility over Bridge, Iowa Department of Transportation	20
3. Typical Pedestrian Facility over Bridge, Iowa Department of Transportation	21
4. Urban bridge with sidewalk, design speed less than or equal to 35 mph (56 km/hr), South Dakota DOT	29
5. Urban bridge with sidewalk, design speed 40 to 45 mph (64 to 72 km/hr), South Dakota DOT	30
6. Urban bridge with sidewalk, design speed 40 to 45 mph (64 to 72 km/hr), South Dakota DOT	31
7. No Barrier Separation - Unlimited Approach Length - Transitions, Guardrails, and Terminals	36
8. No Barrier Separation - Limited Approach Length - Curbs and Buffer Zones	38
9. Barrier Separation Provided - Unlimited Approach Length - Crash Cushion	39
10. Barrier Separation Provided - Unlimited Approach Length - Sloped Concrete End Terminal	41
11. Barrier Separation Provided - Unlimited Approach Length - Transitions, Guardrails, and Terminals	42
12. Barrier Separation Provided - Unlimited Approach Length - Transitions, Guardrails, and Terminals	44
13. Barrier Separation Provided - Unlimited Approach Length - Transitions, Guardrails, and Crash Cushions	46
14. Barrier Separation Provided - Unlimited Approach Length - Transitions, Guardrails, and Crash Cushions	48
15. Barrier Separation Provided - Limited Approach Length - Sloped Concrete End Terminal	50
16. Barrier Separation Provided - Limited Approach Length - Short Radius Guardrail	51
17. Barrier Separation Provided - Limited Approach Length - Short Radius Guardrail	53
18. Barrier Separation Provided - Limited Approach Length - Short Radius Guardrail	54
19. Typical Raised Sidewalk	59
20. No Barrier Separation - Unlimited Approach Length - Curbs, Placebo Barriers, and Buffer Zones	62
21. No Barrier Separation - Unlimited Approach Length - Transitions, Guardrails, and Terminals	63
22. No Barrier Separation - Unlimited Approach Length - Crash Cushions	65
23. No Barrier Separation - Limited Approach Length - Crash Cushions	67
24. No Barrier Separation - Limited Approach Length - Short Radius Guardrails	69
25. Barrier Separation Provided - Unlimited Approach Length - Transitions, Guardrails, and Terminals	72
26. Barrier Separation Provided - Unlimited Approach Length - Transitions, Guardrails, and Terminals	73

27. Barrier Separation Provided - Unlimited Approach Length - Transitions, Guardrails, and Terminals	74
28. Barrier Separation Provided - Unlimited Approach Length - Transitions, Guardrails, and Terminals	75
29. Barrier Separation Provided - Unlimited Approach Length - Crash Cushions	77
30. Barrier Separation Provided - Unlimited Approach Length - Crash Cushions	78
31. Barrier Separation Provided - Unlimited Approach Length - Crash Cushions	79
32. Barrier Separation Provided - Unlimited Approach Length - Low Height Barriers	81
33. Barrier Separation Provided - Limited Approach Length - Crash Cushions	86
34. Barrier Separation Provided - Limited Approach Length - Low Height Barriers	87
35. Barrier Separation Provided - Limited Approach Length - Short Radius Guardrails	88
36. Barrier Separation Provided - Limited Approach Length - Short Radius Guardrails	91

List of Tables

Page

1. Table 4-09.3 from Missouri Department of Transportation Design Manual 24

1 INTRODUCTION

1.1 Problem Statement

Urban arterial streets in heavily populated areas often have bridges that carry large volumes of both vehicular and pedestrian traffic. In these situations, it is desirable to protect the pedestrians from motor vehicles by creating pedestrian facilities that are separated from the motor vehicle lanes. However, transition problems arise at the ends of bridges where the bridge rail, bridge rail end treatment, and pedestrian walkway compete for the limited available space. The configuration of the bridge rail end treatment is further complicated by the geometry of the adjoining roadway or other limiting features at the site, such as roadway drainage and curb usage. For these reasons, roadway designers and engineers have a need for rational guidelines that address pedestrian protection at the ends of bridges. Thus, two questions must be answered: (1) when and to what degree should pedestrians be protected from traffic on bridges; and (2) how should the traffic barriers and transitions be configured for the most common scenarios.

1.2 Background

With the public's increased awareness of environmental concerns, energy efficiency, and individual health benefits, pedestrian traffic is on the rise. As a result, roadway designers must often consider the need for adequate separation between vehicles and pedestrians on roadways, and specifically within the confined conditions on bridges. Bridge design objectives in the past have primarily targeted the accommodation of vehicular traffic, and thus, vehicular bridges are often the only alternatives for pedestrian traffic to cross over obstacles such as interstate highways, railroad tracks, and waterways. When pedestrians and motor vehicles are forced to compete for space, it is apparent that the safety of the pedestrian is inherently at risk. In order to provide for the safety of

the pedestrians on bridges, it is a critical concern to address the separation of these two distinctly different types of traffic during the planning and design process. Currently, there is little in the way of standards or guidelines concerning the various configurations of guardrails and transitions suitable for pedestrian protection near the ends of bridges. The result is that engineers are faced with assessing the site criteria and specifying pedestrian facilities on a case-by-case basis.

1.3 Objective

The first objective of the research project was to identify the most common scenarios in which the protection of pedestrians on bridges is desirable, and then develop bridge rail and bridge rail end treatment configurations to accommodate those situations. In the future, guidelines should be generated to assist designers evaluating pedestrian safety concerns. In addition, a cost-effectiveness or benefit-to-cost ratio approach should be utilized in order to evaluate potential safety improvements when accommodating pedestrians on or near bridges, as well as to aid in the implementation of those pedestrian facilities deemed necessary on bridges, especially near the bridge ends.

1.4 Scope

This study focused on the completion of the first project objective, which included the identification of the most common bridge scenarios that merit the accommodation of pedestrians, as well as the development of the corresponding standard barrier configurations for those scenarios. For this study, it was impractical and unnecessary to conduct full-scale vehicle crash tests for all of the recommended barrier configurations that may be used to provide pedestrian protection. Instead, the barrier configurations outlined within this report were based on several factors. First, when possible, roadside safety hardware that was shown to be acceptable according to the current impact

safety standards provided in the National Cooperative Highway Research Program (NCHRP) Report No. 350 (1) was utilized. Second, if NCHRP Report No. 350-approved hardware was unavailable, then roadside hardware, which either meets prior safety standards, is believed to provide moderate safety, or is currently under development, was considered for providing improved protection and accommodation of pedestrians on or near bridges. Finally, where guidance was unavailable in the literature, sound engineering judgement was also used to aid in the determination of the barrier configurations provided herein. However, it should be noted that the barrier configurations recommended herein are not equivalent in terms of the level of pedestrian safety provided. As a result, the engineer and designer must use sound engineering judgement when determining which barrier configuration to implement.

The first objective of this study was achieved by performing a field investigation, a survey of state transportation agencies, and an extensive literature review. The field investigation and state survey assisted in identifying the most common situations where pedestrian protection is desired. The literature review focused on the many NCHRP Report No. 350 (1) crash tested bridge rails, the various types of bridge rail end treatments, and the standards that pertain to the design of bridge rails, pedestrian rails, sidewalks, curbs, and other pedestrian facilities. Once the field investigation, state survey, and literature review were completed, the information was evaluated, organized, and documented. Recommendations for the placement and configuration of standard barrier configurations were then made in the form of generalized site drawings.

There is a need for design guidelines that would assist roadway and bridge engineers to determine when pedestrian protection on bridges is warranted. It is currently believed that these design guidelines will be developed as a part of NCHRP Project 22-12(2). The procedures used to

establish the guidelines will be based on a detailed Benefit/Cost analysis of the risk to pedestrians associated with unshielded sidewalks on bridges. It is interesting to note that the risk to pedestrians is only moderately higher on bridges than on any sidewalk placed close to a roadway. Hence, it is recommended that protection of pedestrians adjacent to any roadway should be explored in a future study.

2 LITERATURE REVIEW

2.1 Introduction

Many existing publications address the various aspects of pedestrian protection on bridges. Relevant topics include specifications for both bridge and pedestrian railings, combination vehicle/pedestrian railings, bridge railing end treatments, approach guardrail transitions, standard guardrail, guardrail end terminals, curb geometry, sidewalk geometry, and various combinations thereof. A brief summary of the currently available information relevant to the protection of pedestrians on or near bridges is included in the following sections.

2.2 Pedestrian and Bicycle Facilities

Increased pedestrian and bicycle traffic has resulted in an increased demand for engineering guidelines for use in specifying pedestrian and bicycle facilities. Historically, general guidance can be found in several publications on the accommodation of pedestrians and bicyclists as they relate to their corresponding pathways. A literature review summary on those pathways as well as on the separation of pedestrians and vehicles is provided herein.

2.2.1 Pathway Guidance

Sidewalks, walkways, and shared use paths are often placed adjacent to roadways to accommodate pedestrian traffic. As a result, engineers and designers must strive to maintain the safety of the users when specifying the geometry of these pathways. According to *A Policy on Geometric Design of Highways and Streets* (the Green Book), published by the American Association of State Highway and Transportation Officials (AASHTO), walkway width may vary from 1,220 to 2,440 mm, and an additional 610 mm of width should be added when the sidewalk is placed adjacent to a curb (2). In cases where sidewalks are built adjacent to high-speed highways,

buffer zones should be incorporated to separate the pedestrian path from the traveled way for additional pedestrian safety. The guidelines given previously can also be applied to pedestrian accommodations on bridges. However, it is noted that due to unique bridge site features and higher installation costs, pedestrian path details on bridges will often differ from those used along the approach roadway (2). For example, AASHTO's *LRFD Bridge Design Specifications* recommends a 1,524 mm minimum width for a raised sidewalk on a bridge (3), which is 305 mm narrower than the guidelines given in the Green Book.

AASHTO's *Guide for the Development of Bicycle Facilities* (the Bicycle Guide) (4) specifically addresses bicycle path width. It states that any facility designed for use by bicyclists should have a minimum width of 1,220 mm. In locations with high traffic volumes, substantial truck traffic, or vehicle speeds exceeding 80 km/hr, a bicycle path width of 1,524 mm is preferable and additional width is desirable for the accommodation of bicycle traffic (4).

In addition to adequate pathway width and placement, maintaining continuity and consistency of the pathway is important for the safe and efficient movement of pedestrians and bicyclists, especially near bridge approaches (2,4). In general, sidewalks are inappropriate for the accommodation of bicyclists, except for infrequent uses such as crossing long, narrow bridges. Therefore, sidewalks should be reserved for primary use by pedestrians on foot (4,5). Both pedestrian and bicycle paths should have a smooth surface and a 2 percent minimum cross slope in order to provide for adequate water drainage. An adequate cross slope will minimize several safety concerns such as water ponding, accumulation of debris, and ice formation (4). All walkways and sidewalks must also be designed to accommodate the physically handicapped (2).

2.2.2 Separation Guidance

The most desirable method for protecting pedestrians and bicyclists is to separate them from vehicular traffic (6). Separation can be defined as any method used to reduce or eliminate the vehicular hazard to pedestrians and bicyclists. General separation techniques could include horizontal distance, vertical grade, or physical barrier separation. However, it is a difficult task for engineers to match an appropriate separation method with the required facility need due to the lack of available objective guidance regarding pedestrian protection (6). Though desirable, lateral separation over a distance or the use of grade separations are sometimes impractical solutions, and thus, pedestrian and bicycle pathways are often placed adjacent to vehicular traffic lanes.

Because of the inherent differences between pedestrian and vehicular traffic, pedestrians are at high risk from errant vehicles. In these cases, it is often desirable to specify protection for pedestrians in the form of barrier separation. The *Roadside Design Guide (RDG)* (6), recommends the use of a barrier curb to separate vehicles and pedestrians on low-speed roadways with speeds less than 40 km/hr. Although no specific guidance is given, the use of other separation techniques are recommended for roadways with speeds greater than 40 km/hr (6). In addition, the *RDG* states, “In low-speed situations with the bridge railing at the outer edge of the sidewalk, a raised sidewalk may provide some protection for pedestrians”(6). Where bridges are used to accommodate both vehicles and pedestrians, separation is of prime concern due to the limited available width and fewer escape routes for pedestrians. In these cases, separating vehicle and pedestrian lanes with a bridge railing provides the maximum pedestrian protection (6). Specifically, on urban expressway bridges, AASHTO’s *Standard Specifications for Highway Bridges* (7) recommends that pedestrian lanes should be separated from vehicle lanes with combination vehicle/pedestrian bridge railings.

2.3 Bridge Railings

In addition to the available guidance concerning pedestrian and bicycle facilities, there also exists engineering guidelines directed toward specifying bridge railings for pedestrian accommodation and safety. For example, AASHTO's *LRFD Bridge Design Specifications* addresses a situation where a pedestrian pathway is placed between the vehicle lanes and the bridge railing (3). It states that combination vehicle/pedestrian bridge railings, used in conjunction with a raised sidewalk and a 152 to 203-mm tall curb, should only be used on low-speed highways with posted speeds of 72 km/hr or less. AASHTO's *RDG* states that the need for shielding of pedestrians and bicyclists on bridges is based on several factors, such as traffic volumes and vehicle speeds, the volume of pedestrian and bicycle traffic, and the geometrical conditions at the ends of the bridge (6). However, the *RDG* provides no specific guidance as to when a pedestrian path should be protected by a bridge railing system. In cases where a bridge railing is placed between vehicle lanes and the sidewalk, a pedestrian railing is required on the outside edge of the pathway (6). AASHTO's *Standard Specifications for Highway Bridges* is somewhat more specific in its guidance as it recommends the use of combination bridge railings to separate pedestrian and vehicle lanes on urban expressway bridges, with additional pedestrian railings placed on the outside edge of the bridge (7). Finally, AASHTO's *LRFD Bridge Design Specifications* is even more specific in its guidance when it recommends the shielding of pedestrian paths on high-speed roadways, with posted speeds of 80 km/hr or more, using combination bridge railings with additional pedestrian railings on the outside edge of the pathway (3). On bridges, pedestrian-only railings should be a minimum of 1,067-mm tall, bicycle railings should be a minimum of 1,372-mm tall, and combination railings should conform to the respective pedestrian or bicycle railing requirements depending on the facility type

(3,7). AASHTO's Bicycle Guide recommends a minimum railing height of 1,067 mm for both bicycle railings and combination vehicle/bicycle railings (4), which is in contrast to the 1,372-mm railing height specified in AASHTO's Standard and LRFD Bridge Specifications (3,7).

2.4 Bridge Railing End Treatments

The ends of rigid concrete bridge railings provide a significant hazard to vehicles and their occupants, and unfortunately, adequately shielding the ends of bridge rails often presents a significant problem for engineers. Exposed bridge rail ends and sharp changes in railing geometry should be avoided, and a smooth stiffness transition between the bridge rail and the adjoining barrier system should be provided to prevent pocketing and snagging of an impacting vehicle (2, 7). Various bridge rail end treatments or transitional barrier systems are available to protect traffic from direct impact with the bridge rail ends. Incorporation of these transitional structures should not impede pedestrian traffic if an adjacent walkway is present (2). It is required that the entire length of need associated with the hazard or obstruction must be effectively shielded, either by the selected bridge rail end treatment or the bridge rail itself (6). Other obstructions, such as intersecting roadways, streets, and drives often make it difficult to adequately shield the ends of bridge railings and/or provide the required length of need. AASHTO's *RDG* states that the best solution is to relocate the intersecting road and to install a standard bridge rail end treatment (6). When is it not possible to use a standard bridge rail end treatment, other means should be used in an attempt to shield the bridge rail end and the hazard located behind the bridge rail. However, it is noted that using non-standard methods of terminating bridge railings often compromises the barrier's ability to effectively shield the hazards, and often results in some sacrifice in the crashworthiness of the barrier (6).

2.5 Curbs

AASHTO's Green Book defines two types of curbs: vertical curbs and sloping curbs (2). Vertical curbs were originally designed to inhibit or discourage vehicles from leaving the roadway. Vertical curbs are typically between 152 and 229-mm tall and are characterized by their tall, steep faces. On the contrary, sloping curbs were designed to intentionally allow vehicles to mount and cross over them. Sloping curbs are typically between 102 and 152-mm tall and have sloping, well rounded faces (2).

Vertical curbs serve several purposes, such as discouraging vehicles from leaving the roadway, delineating pedestrian walkways or pavement edge, and channeling water runoff (2). According to Olsen et al, it has been shown that vertical curbs are inadequate for redirecting errant vehicles that leave the roadway (8). As a result, the primary use of vertical curbs concerning pedestrian protection is for delineation of the vehicle and pedestrian lanes. Although vertical curbs will not provide shielding of the pedestrian facility, there is some positive effect on delineation as they tend to discourage the mingling of the two distinctly different traffic types. State transportation agencies, surveyed in the ongoing NCHRP study, Project 22-17 *Recommended Guidelines for Curbs and Curb-Barrier Combinations* (9), identified drainage control as the primary or secondary reason for specifying vertical curbs. Walkway support and pavement delineation were also highly rated.

AASHTO's Green Book and *RDG* state that sloping curbs typically provide roadway delineation and channelization of water runoff (2, 6). Although sloping curbs were originally intended to be used in areas where pedestrian protection was not a concern, the failure of vertical curbs to offer any significant protection has prompted some agencies to begin using sloping curb designs adjacent to sidewalks. A state agency survey conducted within NCHRP Report 22-17

revealed that the primary functional purpose for using both vertical and sloping curbs is to provide roadway drainage (9).

Both AASHTO's Green Book and *RDG* state that neither vertical nor sloping curbs should be used on freeways or high-speed roadways (2,6). The *RDG* recommends the use of vertical curbs as a technique to separate vehicles and pedestrians only on low-speed roadways where speeds are less than 40 km/hr (6). For roads with speeds greater than 40 km/hr, other safety provisions should be made to shield pedestrians (6).

There are some conflicting views toward the use of curbs on bridges. AASHTO's *Standard Specifications for Highway Bridges* states that curb heights on bridges should be equal to or greater than curb heights on the approach roadways (7). If there is no curb on the approach roadway, the curb height on the bridge should be between 203 to 254 mm (7). AASHTO's *LRFD Bridge Design Specifications* recommends that the curb height for raised sidewalks on bridges should be a maximum of 203 mm (3).

Currently, there is much concern and controversy regarding curbs used in conjunction with roadside barriers. This fact is primarily due to the limited amount of data that is available. In 1974, NCHRP published Report No. 150, *Effect of Curb Geometry and Location on Vehicle Behavior*, which provided research results concerning the effect that various mountable and barrier curbs have on the trajectory of an impacting vehicle (8). The crash test data revealed that vehicular impacts with curbs can create post-impact trajectories that lead to vehicular vaulting of 686-mm high W-beam guardrail when located behind the curb. Initial front-end dipping of the test vehicle was also observed, subsequently revealing the potential for underride and snagging of the guardrail barrier. An example illustration of a vehicle's bumper trajectory after an impact with a curb is provided in Figure 1.

AASHTO's Green Book and AASHTO's *RDG* both give limited guidance on curb/barrier combinations (2.6). In general, vertical curbs and sloping curbs should not be used in conjunction with traffic barriers because the curb may cause vehicular vaulting of the barrier. In locations where it is not possible to eliminate a curb/barrier combination, the curb should either be located behind the barrier or flush with the barrier face so the vehicle trajectory is not altered prior to impact with the barrier (2.6). Also, the use of a curb no higher than 100 mm and/or stiffening of the guardrail to reduce its deflection may help to maximize the crashworthiness of the curb/barrier combination (6). If extensive use of a curb/barrier combination is planned, and if there is no crash test data from a similar test to make an informed judgement, the curb/barrier combination should be verified with the use of a full-scale vehicle crash test (6).

Effective drainage, while one of the most important features to consider in roadway design, should be implemented in a manner that considers the effect it has on other roadside safety features (6). Thus, curbs and other drainage features (i.e., raised inlets, curb inlets, ditches, or swales) must be designed for both hydraulic efficiency and roadside safety (6). Swales, or drainage ditches, can often be used in lieu of curbs to handle drainage concerns (9). However, engineers should use caution when specifying drainage features to be placed in front of barriers, since those features can lead to vehicular instabilities that can adversely affect the crashworthiness of the barrier system (6). Finally, due to the potential for vehicular vaulting of the guardrail, the slope between the driving lane and the barrier should be no steeper than 10:1 (6).

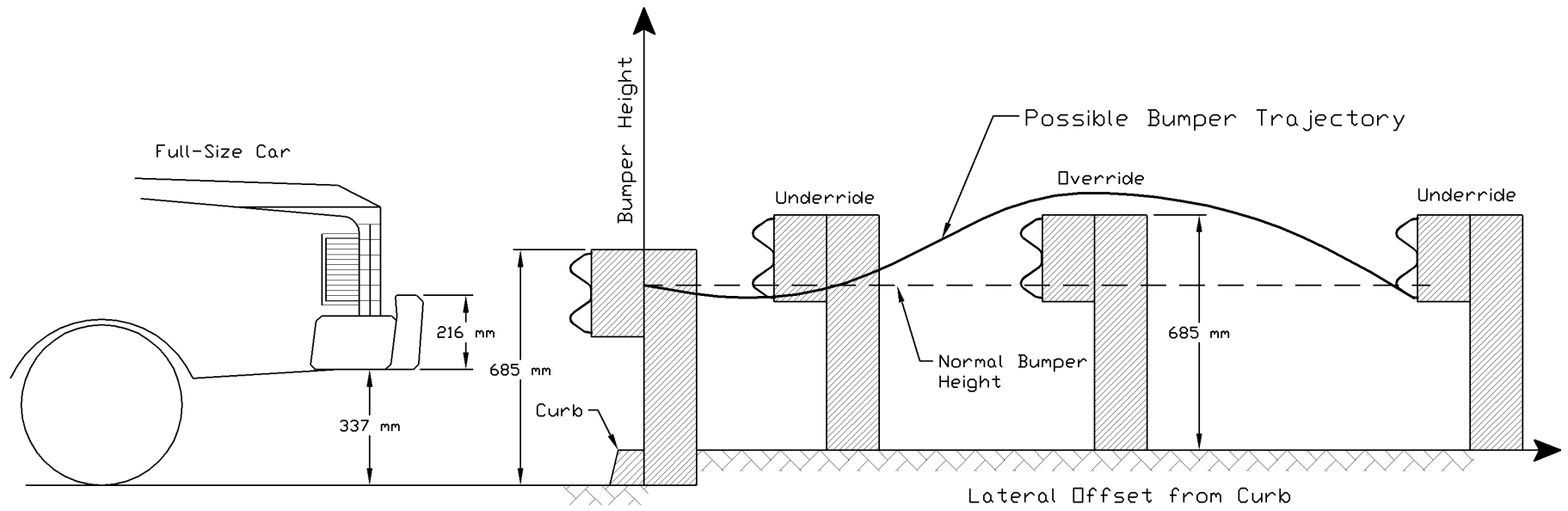

Figure 1. Vehicle Bumper Trajectory Illustration (9).

NCHRP Report 22-17, *Recommended Guidelines for Curbs and Curb-Barrier Combinations*, is an ongoing study that is investigating the consequences of combining curbs and traffic barriers on roadways with vehicle speeds greater than 60 km/hr (9). This study will utilize computer simulation, crash test data analysis, and full-scale crash testing to investigate vehicle behavior during impacts with curb/barrier combinations. When completed, this study should yield some new insights with which objective guidelines concerning curb/barrier combinations can be developed.

2.6 Relevant Approved Hardware

The following is a listing of roadside hardware configurations that have been crash tested and approved for use according to the NCHRP Report No. 350 safety standards. These roadside hardware configurations have been included herein because they are suitable for use in the safe accommodation of pedestrians on or near the ends of bridges.

2.6.1 Approach Guardrail Transition with Curb

Historically, approach guardrail transitions have been used to provide a lateral stiffness transition between the bridge rail and the attached guardrail system and to prevent vehicles from impacting the blunt end of the bridge rail. However, when used in a pedestrian situation, the approach guardrail transition system can also effectively shield the pedestrians behind the barrier.

For some bridge applications, there is also a need to carry the water runoff from the bridge to a point beyond the end of the bridge railing. As a result, a curb system is often utilized below the approach guardrail transition, and even the standard guardrail, in order to provide hydraulic drainage. However, prior crash testing has shown that curbs placed in front of or below guardrail systems can result in override of the barrier as well as vehicular instabilities (8). Therefore, the need exists to have crashworthy approach guardrail transition designs that are acceptable for use with a curb.

In 1998, the Midwest Roadside Safety Facility (MwRSF) developed and crash tested two thrie beam approach guardrail transition systems that incorporated a 102-mm high by 178-mm wide triangular shaped lip curb (10, 11). These two transition systems successfully met the Test Level 3 (TL-3) requirements specified in NCHRP Report No. 350.

2.6.2 W-beam Guardrail Over Curbs

Prior research has shown that the crashworthiness of a guardrail system can be compromised when used in conjunction with or near curbs (8). However, two recent studies have shown acceptable safety performance of W-beam guardrail systems placed over curbs according to the TL-3 standards of NCHRP Report No. 350. In the first study, the Texas Transportation Institute (TTI) successfully crash tested a G4(2W) W-beam guardrail system placed over a 100-mm high asphalt curb according to the TL-3 criteria of NCHRP Report No. 350 (12). In the second study, MwRSF conducted two separate crash tests on guardrail systems placed above a curb. In the first test, a modified G4(1S) W-beam guardrail system, installed over a 102-mm high by 203-mm wide triangular-shaped lip curb, was unsuccessfully crash tested according to the TL-3 criteria of NCHRP Report No. 350 (13). In a follow-up crash test, a modified G4(1S) guardrail system with double nested W-beam rails was placed over a 102-mm high by 203-mm wide triangular-shaped lip curb and successfully crash tested according to the TL-3 criteria of NCHRP Report No. 350 (14).

2.6.3 Combination Vehicle/Pedestrian and Combination Vehicle/Bicycle Bridge Rails

In 1998, MwRSF successfully developed and crash tested a combination vehicle/bicycle bridge rail according to Test Level 4 (TL-4) requirements of NCHRP Report No. 350 (15). This combination bridge railing system incorporated a steel tubular bicycle railing which was attached to the back-side face of a standard New Jersey safety shaped barrier. For this application, both the

vehicle and bicycle traffic were intended to be on the traffic-side face of the bridge railing system. However, if this railing were used to separate the vehicle and bicycle lanes, additional consideration would be necessary to insure that the back side of the railing were free of protruding posts that could pose a hazard to the bicyclists.

TTI successfully developed and crash tested the BR27D and BR27C combination vehicle/pedestrian bridge railings (16). Both railing designs were constructed and crash tested in two configurations - mounted on a raised sidewalk and mounted flush with the bridge deck. The BR27D railing was successfully tested according to the Performance Level 1 (PL-1) criteria found in AASHTO's *Guide Specifications for Bridge Railings* (17) and was later approved for use in applications requiring NCHRP Report No. 350 TL-2 systems. The BR27C railing was successfully tested according to PL-2 criteria found in AASHTO's *Guide Specifications for Bridge Railings* (17) and was later approved by FHWA's crash testing equivalency rating for use in applications requiring NCHRP Report No. 350 TL-4 systems.

Another combination vehicle/pedestrian bridge railing, the Texas Type C411, was successfully developed and crash tested by TTI (18). The combination railing was constructed on top of a raised sidewalk and was crash tested with both 2,000-kg (4409-lb) and 860-kg (1896-lb) vehicles. The crash test results indicated that the railing was suitable for use on low-speed roads of 72 km/hr or less. The Texas Type C411 bridge railing was later approved by FHWA's crash testing equivalency rating for use in NCHRP Report No. 350 TL-2 applications.

Finally, the New England Transportation Consortium (NETC) successfully developed a sidewalk-mounted, combination vehicle/pedestrian steel bridge railing system (19). The four-bar steel railing was successfully tested according to TL-3 criteria of NCHRP Report No. 350.

2.6.4 Low-Height Bridge Rails and Barriers

For low-speed roadways and bridges, low-height barriers are installation options where site restrictions prevent the use of conventional barriers. In some cases, it may be appropriate to use low-height barriers for pedestrian protection. In 1992, TTI developed and crash tested a low-profile portable concrete barrier and a corresponding sloped end treatment which was deemed acceptable for use on low-speed roadways of 72 km/hr or less (20-22). In 2001, MwRSF successfully developed and crash tested a low-profile bridge railing system according to the TL-2 criteria of NCHRP Report No. 350 (23). A sloped-concrete end terminal, based on prior testing of TTI's terminal, was also developed for use with the MwRSF low-profile bridge railing. The University of Florida also successfully developed and crash tested a low-profile work-zone barrier according to the NCHRP Report No. 350 TL-2 criteria (24).

3 STATE STANDARDS, PRACTICES, AND SPECIFICATIONS

3.1 Introduction

A survey of the state highway agencies participating in the Midwest States' Regional Pooled Fund Program was conducted to identify current practices regarding pedestrian protection on bridges. Each of the 11 states in the Pooled Fund Program was asked to submit relevant information that pertains to guidance utilized by engineers when specifying pedestrian facilities on or near bridges. Beneficial information included state derived standards and specifications, commonly accepted design practices, region specific concerns, and other general knowledge that helped guide the study. Below is a summary of the relevant information that was provided.

3.2 Iowa Department of Transportation

The Iowa Department of Transportation contributed the following general guidance which pertains to the protection of pedestrians and bicyclists on and near the ends of bridges.

3.2.1 Pedestrian and Bicycle Facilities

- Barrier separation of pedestrian and traffic lanes is provided on all new projects regardless of traffic speed and type.
- In situations where old bridges with limited available width are being refurbished for pedestrian accommodation, a curbed and elevated sidewalk can be used for delineation between vehicle and pedestrian lanes.

3.2.2 Bridge Railings

- No information on this topic was provided.

3.2.3 Bridge Railing End Treatments

- For state highways with a posted speed of 35 mph (56 km/hr) or greater, a concrete barrier with crashworthy end treatment (either guardrail or impact attenuator) is used to separate vehicular and pedestrian lanes.

- For posted speeds under 35 mph (56 km/hr), a concrete barrier with a sloped concrete end treatment is used between vehicles and pedestrians.

3.2.4 Curbs

- No information on this topic was provided.

3.2.5 Typical Pedestrian Facilities

Figures 2 and 3 illustrate typical pedestrian facilities over bridges that are used by the Iowa Department of Transportation.

3.3 Kansas Department of Transportation

The Kansas Department of Transportation (KDOT) contributed the following guidance which pertains to the protection of pedestrians and bicyclists on and near the ends of bridges.

3.3.1 Pedestrian and Bicycle Facilities

The following guidance that is relevant to pedestrian and bicycle facilities is documented in the KDOT Design Manual, Volume III, Bridge Section, Section 3.2.10.3, Sidewalks (25).

- Sidewalks used on bridges should have a minimum clear width of 1,500 mm.
- Designated bikeways should have a minimum useable clear width of 2,450 mm.
- As a general rule, pedestrians and bicyclists should be separated.

3.3.2 Bridge Railings

The following guidance for bridge railings is documented in the KDOT Design Manual, Volume III, Bridge Section, Section 3.2.10.2, Railings (25).

- “If the design of a (bridge) structure includes a sidewalk, a concrete barrier rail will be used between the traveled way and the sidewalk.”
- “For design speeds less than or equal to 65 km/hr, the minimum height of the separator railing above the sidewalk shall be 600 mm and the railing surface shall be smooth to avoid snag points for pedestrians or cyclists.”

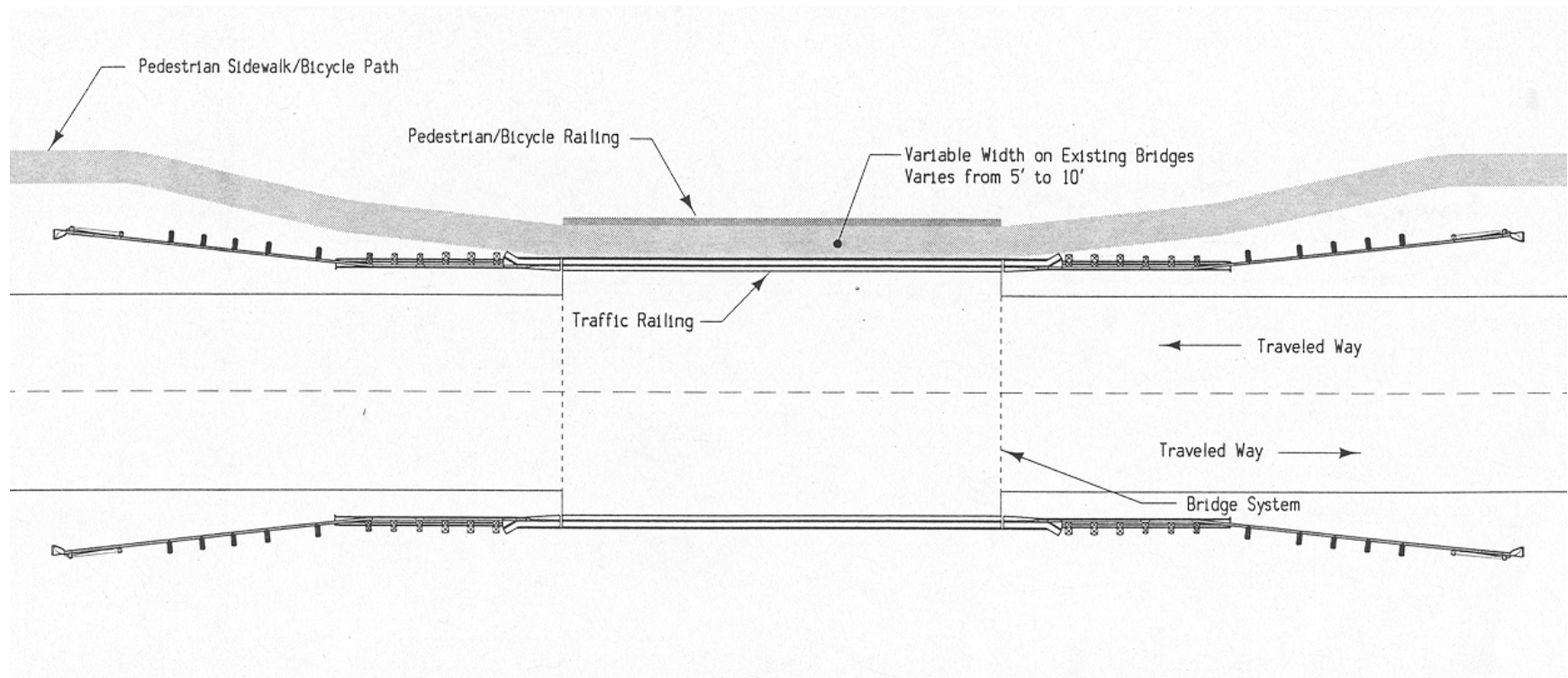

Figure 2. Typical Pedestrian Facility over Bridge, Iowa Department of Transportation

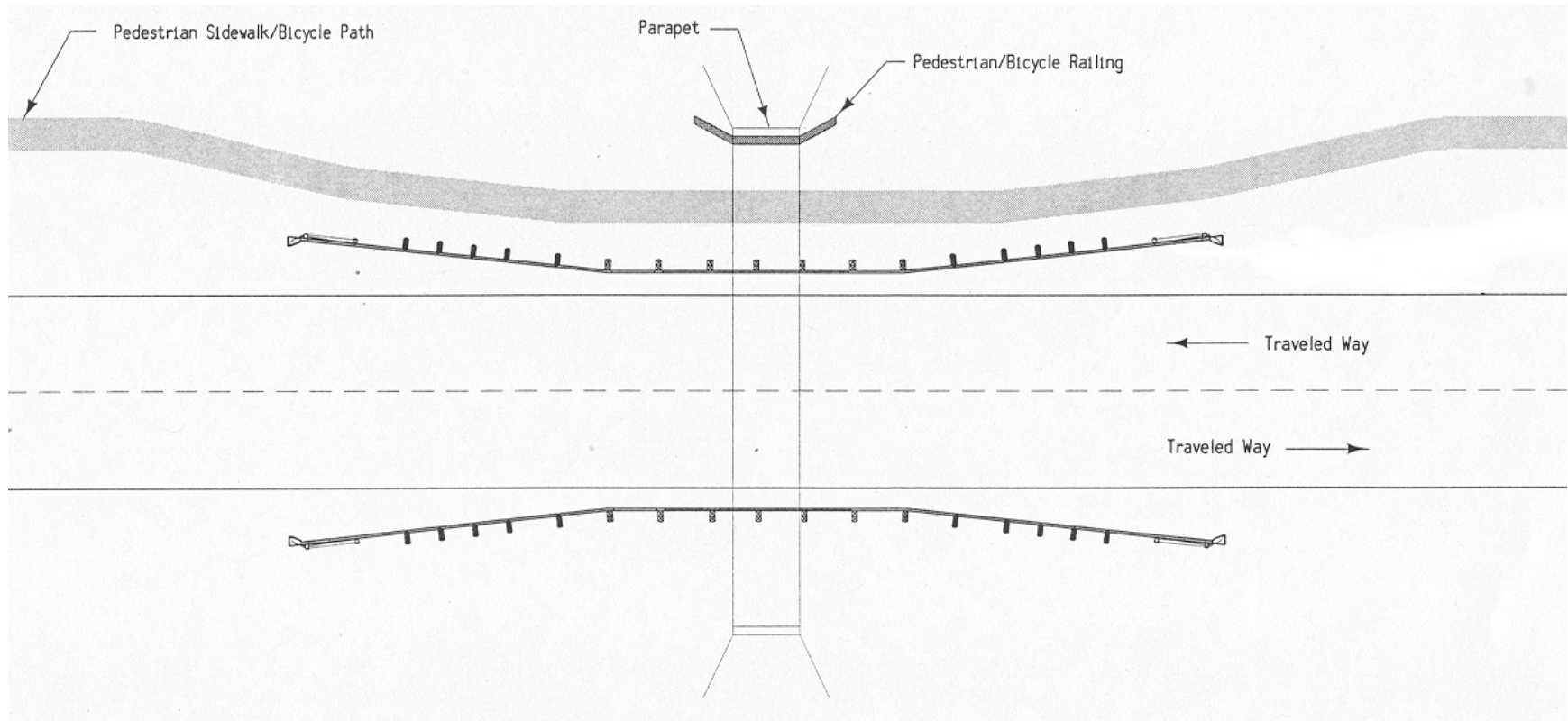

Figure 3. Typical Pedestrian Facility over Bridge, Iowa Department of Transportation

- “For design speeds over 65 km/hr, or if a high volume of bike traffic is expected and the risk involved if a cyclist would fall over the separator is great, use a minimum railing height of 1,070 mm.”
- “The height of the railing on the outside edge of the sidewalk shall be a minimum of 1,070 mm for pedestrians and a minimum of 1,370 mm for bicycles.”
- “Chain link fence on bridges over the Interstate in urban areas shall be 1,830 mm high. At other locations, chain link fence shall be 1,370 mm high.”

3.3.3 Bridge Railing End Treatments

- No information on this topic was provided.

3.3.4 Curbs

The following guidance for curbs is documented in the KDOT Design Manual, Volume III, Bridge Section, Section 3.2.10.1, Curbs (25).

- “Where curb and gutter sections are used on the roadway approach, a closed section of rail on the bridge should match that on the road curb, except it may exceed the road curb height on the approach.”
- “Bridge curbs serve the purposes of drainage control and delineation of pedestrian walkways.”
- “Curbs shall be designed in accordance with AASHTO Articles 2.2.5 and 3.14.2.”, which references AASHTO’s *Standard Specifications for Highway Bridges* (7).
- “Current KDOT policy is not to use brush curbs on bridges.”

3.4 Missouri Department of Transportation

The Missouri Department of Transportation (MoDOT) contributed the following guidance which pertains to the protection of pedestrians and bicyclists on and near the ends of bridges.

3.4.1 Pedestrian and Bicycle Facilities

The following guidance for pedestrian and bicycle facilities is documented in the MoDOT Design Manual, Chapter IV, Detail Design, Section 4-09.26, Bicycle/Pedestrian Facilities (26).

- Pedestrian and/or bicyclist accommodations should be considered when “the route provides access across a natural or man-made barrier, i.e, bridges over rivers, roadways or railroads, or under access-controlled facilities and roadways.”
- “The design and installation of pedestrian and bicycle facilities is at the sole discretion of the director or designee. Documentation should be developed on all projects to support the decision to provide or not provide pedestrian and/or bicycle accommodations.”
- “The AASHTO publication *Guide for the Development of Bicycle Facilities* and FHWA-RD-92-073 *Selecting Roadway Design Treatments to Accommodate Bicycles* provide guidance for bicycle and multi-use facilities.”
- “Table 4-09.3 provides guidance on the application of bicycle/pedestrian facilities with respect to roadway classification.” Refer to Table 1.
- “When provided, sidewalks should have a minimum width of 5 ft (1.5 m). The absolute minimum sidewalk width allowed by ADA (Americans with Disabilities Act) guidelines is 3 ft (0.9 m).”
- “A sidewalk proposed within 2 ft (0.6 m) of a curb should be adjacent to the curb, a minimum of 6 ft (1.8 m) wide and located behind a barrier curb.”
- “A pedestrian grade separation should only be constructed when the need for the safe movement of pedestrians cannot be solved in some simpler and more economical manner.”

3.4.2 Bridge Railings

- No information on this topic was provided.

3.4.3 Bridge Railing End Treatments

The following guidance relevant to bridge railing end treatments is documented in the MoDOT Design Manual, Chapter IV, Detail Design, Section 4-09.7, Guardrail ([26](#)).

- “Approved crashworthy end terminals are provided on guardrail placed for bridge end protection.”
- Approved crashworthy end terminals are defined as terminals that have successfully passed NCHRP 350 test criteria and have been approved by the FHWA.

**TABLE 4-09.3
BICYCLE FACILITIES**

	Bicycle Path	Bicycle Lane	Wide Shared Lane	Bicycle Lane on, or Bicycle Usage of, Shoulder
Interstate	Permitted	Not Permitted	Not Permitted	Possible Solution*
Urban Freeway	Permitted	Not Permitted	Not Permitted	Possible Solution*
Principal Arterial	Permitted	Possible Solution	Possible Solution	Possible Solution
Urban Principal Arterial	Permitted	Possible Solution	Possible Solution	Possible Solution
Minor Arterial	Permitted	Permitted	Permitted	Permitted
Urban Minor Arterial	Permitted	Permitted	Permitted	Permitted
Collector	Permitted	Permitted	Permitted	Permitted
Local	Permitted	Permitted	Permitted	Permitted

Definitions:
Permitted: This design is allowed with this functional class.
Not Permitted: This design is not allowed with this functional class.
Possible Solution: This design may be considered but requires further analysis of geometrics and traffic characteristics to determine proper design for given conditions.
 *This solution should only be considered when all other reasonable alternatives are not practical and this routing is needed to provide continuity of local and cross country bicycle routes.

Table 1. Table 4-09.3 from Missouri Department of Transportation Design Manual (26)

- “All downstream ends on two-way roadways are provided with an approved crashworthy end terminal.”
- “The length of need and the flare rate of the guardrail shall be determined in accordance with the procedures contained in Section 5.6.4 of the AASHTO *Roadside Design Guide*.”
- “Guardrail is not generally used to protect traffic from the ends of bridges carrying a crossroad or street over the through lanes in developed areas where speed controls exist or sidewalks are provided.”

3.4.4 Curbs

The following guidance for curbs is documented in the MoDOT Design Manual, Chapter IV, Detail Design, Section 4-09.3, Curbs (26).

- “Curbs, and curb and gutter, are used to channelize and guide traffic, to mark traffic lanes, to define medians for safety, to simplify handling drainage, and to reduce right of way requirements.”
- “When curbs are constructed directly beneath guardrail the curb height will be 4 in (102 mm).”
- “Curbs are designed and located so that they are not hazardous to traffic.”
- “Barrier type curbs are used in conjunction with other parallel vertical elements such as walls, bridge rails, adjacent to sidewalks, etc.”
- “Barrier type curbs are offset from the edge of traffic lanes by at least 1 ft (300 mm), except curbs adjacent to auxiliary lanes 12 ft (3.6 m). At least a 4 ft (1.2 m) curb offset is desirable for short curb sections and for islands.”

3.5 Minnesota Department of Transportation

The Minnesota Department of Transportation (MnDOT) contributed the following guidance which pertains to the protection of pedestrians and bicyclists on and near the ends of bridges.

3.5.1 Pedestrian and Bicycle Facilities

The following guidance relevant to pedestrian and bicycle facilities is documented in the MnDOT Bridge Design Manual, Section 5-392.201 D, Bridge Sidewalks and Bikeways (27).

- “Bridge sidewalks of 1.8 meters minimum widths should be provided where justified by pedestrian traffic. If bicycle traffic is expected the width should be 2.4 meters minimum and 3.0 meters desirable.”
- “Sidwalks and bikeways shall have a minimum cross slope of 0.01 meters per meter.”

3.5.2 Bridge Railings

The following guidance relevant to bridge railings is documented in the MnDOT Bridge Design Manual, Section 5-392.201 D, Bridge Sidewalks and Bikeways (27).

- “When the design speed on the street is over 60 km/hr a concrete barrier is required between the roadway and the sidewalk (or bikeway) and a pedestrian (or bikeway) railing is required on the outside.”
- “When a barrier is provided between the traffic lanes and the sidewalk, the bridge slab shall normally be used for the walkway.”

3.5.3 Bridge Railing End Treatments

The following guidance for bridge railing end treatments is documented in the MnDOT Bridge Design Manual, Section 5-392.201 E, Protective Rails at Bridge Approaches (27).

- “The ends of bridge railings must be protected from being impacted (except on low speed roads such as city streets). For design speeds over 60 km/hr, a crash tested guardrail transition (normally plate beam guardrail) is required.”

3.5.4 Curbs

The following guidance relevant to curbs is documented in the MnDOT Bridge Design Manual, Section 5-392.201 D, Bridge Sidewalks and Bikeways (27).

- “The curb height for sidewalks adjacent to the roadway (on bridges) is 200 mm minimum.”

3.6 South Dakota Department of Transportation

The South Dakota Department of Transportation (SDDOT) contributed the following guidance which pertains to the protection of pedestrians and bicyclists on and near the ends of

bridges. Chapter 3 of the SDDOT Road Design Manual generally states that AASHTO's *Geometric Design of Highways and Streets* (the "Green Book") is to be referenced for design standard guidance when establishing project criteria, and when the SDDOT Road Design Manual does not provide guidance in a particular design area (28).

3.6.1 Pedestrian and Bicycle Facilities

The following guidance relevant to pedestrian and bicycle facilities is documented in the SDDOT Road Design Manual, Chapter 3, Section 6-i, Traffic Needs, Pedestrian Traffic (28).

- "Reference to national standards will be necessary until South Dakota develops more demand for state standards."
- All new bridges that have sidewalks are required to have a concrete barrier between the vehicular traffic and the sidewalk.
- AASHTO's *Guide for the Development of Bicycle Facilities* is used as a general guideline for bicycle and pedestrian accommodation.

3.6.2 Bridge Railings

- No information on this topic was provided.

3.6.3 Bridge Railing End Treatments

- If the design speed is less than or equal to 35 mph (56 km/hr), a sloped concrete terminal is used to protect the end of the bridge rail.
- If the design speed is 40 to 45 mph (64 to 72 km/hr), a guardrail transition or impact attenuator is used to protect the bridge rail and/or median barrier ends.

3.6.4 Curbs

The following guidance for curb usage is documented in the SDDOT Road Design Manual, Chapter 7, Cross Sections, Curbs (28).

- Curbs "generally serve one or more of several purposes: drainage control, pavement edge delineation, delineation of pedestrian walkways, and assistance in orderly roadside development."

- “In the interest of safety, curbs should be omitted on high-speed rural highways when the same objective can be attained by other acceptable means.”
- “Barrier curbs usually are limited to urban areas for typical street sections, with speeds fo 40 mph (60 km/hr) or less.”
- “Mountable curbs can be used at median edges to outline channelizing islands in intersection areas, with speeds greater than 40 mph (60 km/hr). They also may be used at the outer edge of a shoulder to control drainage, improve delineation, and reduce erosion.”

3.6.5 Typical Pedestrian Facilities

Figures 4 through 6 illustrate typical pedestrian facilities over bridges that are used by the South Dakota Department of Transportation.

3.7 Texas Department of Transportation

The Texas Department of Transportation (TxDOT) contributed the following guidance which pertains to the protection of pedestrians and bicyclists on and near the ends of bridges.

3.7.1 Pedestrian and Bicycle Facilities

The following guidance relevant to pedestrian and bicycle facilities is documented in the TxDOT Bridge Railing Manual, Chapter 5, Section 2, Bridge Railing for Pedestrians (29).

- “A vehicular bridge with a design speed of 45 mph (72 km/hr) or less is considered a low-speed facility, and it does not require a separator railing if pedestrians use it.”
- “A bridge with a design speed above 45 mph (72 km/hr) is a high-speed facility, and it must have a separator railing if pedestrians use it.”

The following guidance relevant to pedestrian and bicycle facilities is documented in the TxDOT Bridge Railing Manual, Chapter 5, Section 4, ADA Requirements for Bridge Railing (29).

- “Bridges in excess of 200 feet (61 m) in length must have a 5-foot (1,525-mm) minimum-width sidewalk or must have passing areas every 200 feet (61 m) projecting from the side of the bridge. Handrails meeting ADA requirements are not required at the sides of pedestrian slopes, but a pedestrian or bicycle railing is required.”

URBAN BRIDGE WITH SIDEWALK Design Speed \leq 35 mph

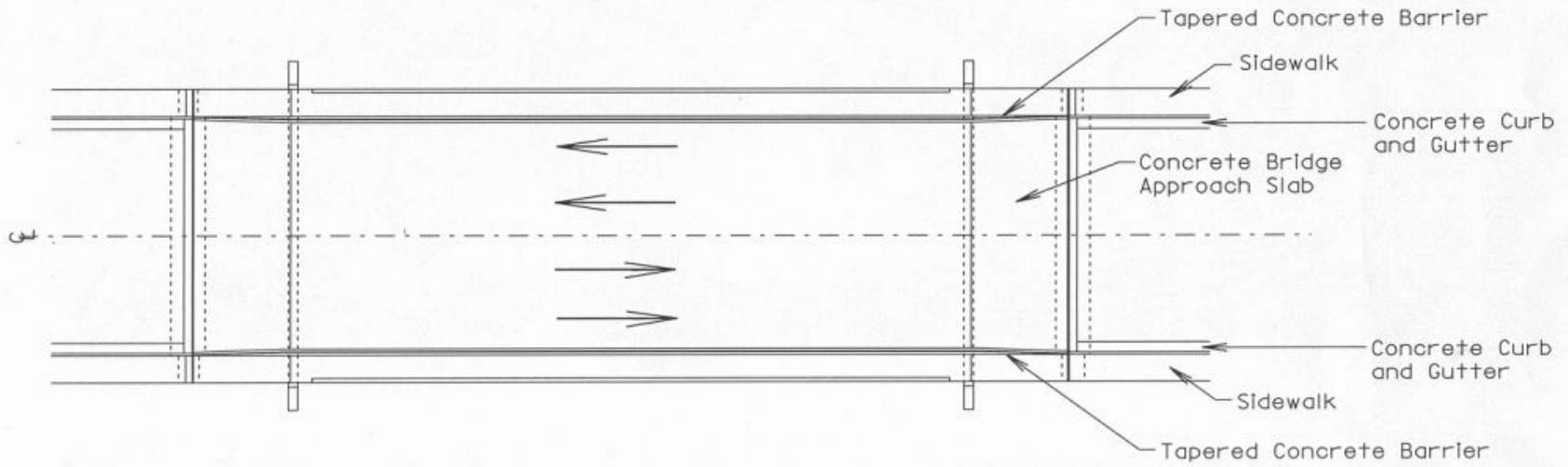

Figure 4. Urban bridge with sidewalk, design speed less than or equal to 35 mph (56 km/hr), South Dakota DOT

SUBURBAN BRIDGE WITH SIDEWALK

Design Speed 40 to 45 mph

30

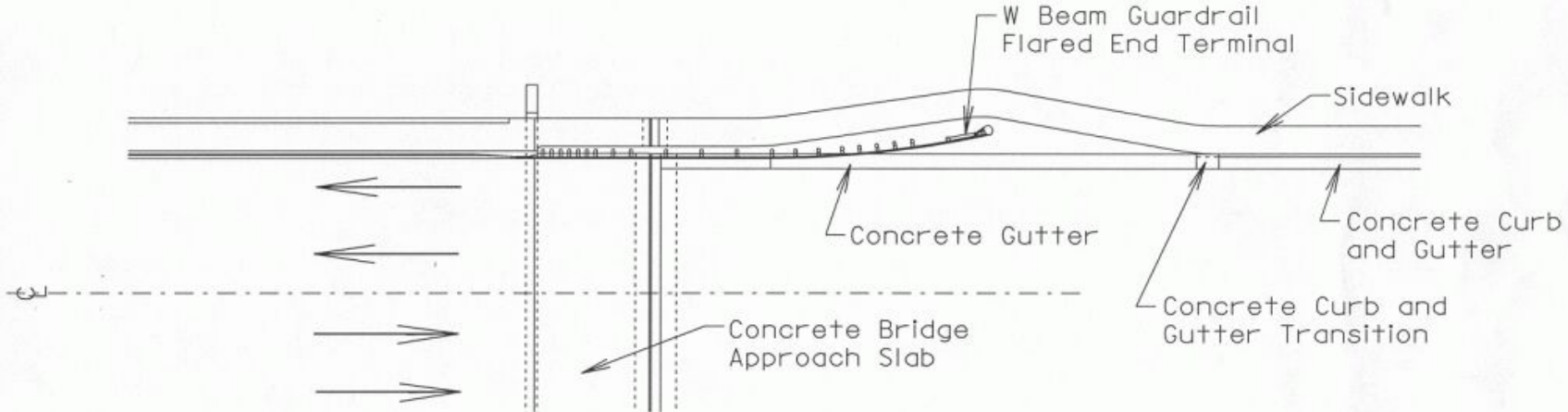

Figure 5. Urban bridge with sidewalk, design speed 40 to 45 mph (64 to 72 km/hr), South Dakota DOT

SUBURBAN BRIDGE WITH SIDEWALK

Design Speed 40 to 45 mph

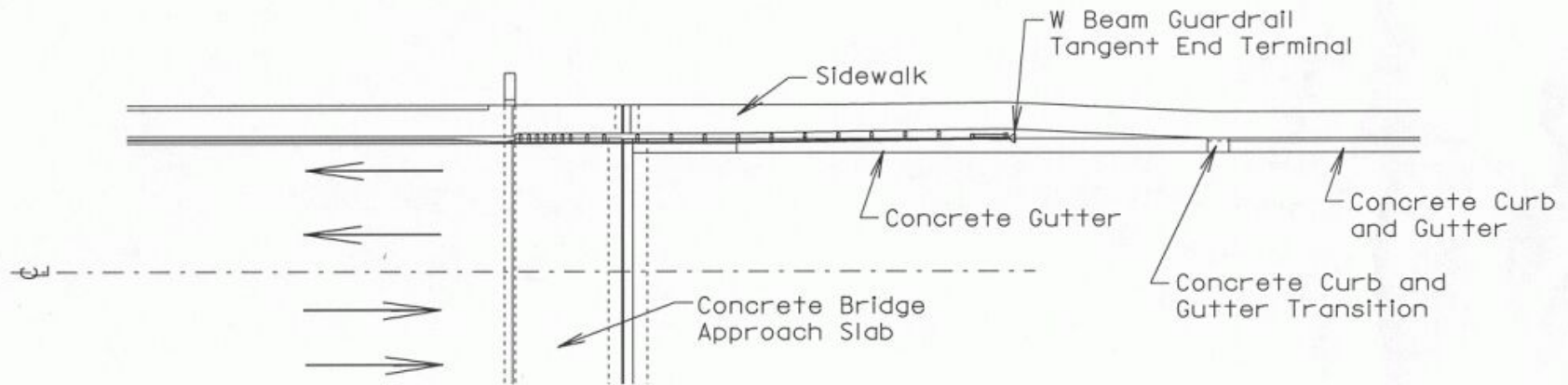

Figure 6. Urban bridge with sidewalk, design speed 40 to 45 mph (64 to 72 km/hr), South Dakota DOT

The following guidance relevant to pedestrian and bicycle facilities is documented in the TxDOT Roadway Design Manual, Chapter 2, Section 6, Sidewalks and Pedestrian Elements (30).

- “Sidewalks provide distinct separation of pedestrian and vehicles, serving to increase pedestrian safety as well as to enhance vehicular capacity.”
- “For pedestrian comfort, especially adjacent to high speed traffic, it is desirable to provide a buffer space between the traveled way and the sidewalk. For curb and gutter sections, a buffer space of 3 ft (915 mm) or greater between the back of the curb and the sidewalk is desirable.”
- “Sidewalks should be wide enough to accommodate the volume and type of pedestrian traffic expected in the area.”
- “The minimum clear sidewalk width is 5 ft (1,525 mm).”
- “Where a sidewalk is placed immediately adjacent to the curb, a sidewalk width of 6 ft (1830 mm) is desirable to allow additional space for street and highway hardware and allow for the proximity of moving traffic.”
- “Sidewalk widths of 8 ft (2,440 mm) or more may be appropriate in commercial areas, along school routes, and other areas with concentrated pedestrian traffic.”

The following guidance relevant to pedestrian and bicycle facilities is documented in the TxDOT Roadway Design Manual, Chapter 6, Section 4, Bicycle Facilities (30).

- “The AASHTO *Guide for the Development of Bicycle Facilities* is the guide for planning, design, construction, maintenance, and operation of bicycle facilities.”

3.7.2 Bridge Railings

The following guidance for bridge railings is documented in the TxDOT Bridge Railing Manual, Chapter 1, Section 3, Texas Policy on Bridge Railing (29).

- “Texas Bridge Railing must meet or exceed design strength specified in the AASHTO *Standard Specifications for Highway Bridges*.”
- “Texas bridge railing on new construction must meet FHWA crash-test criteria as specified in NCHRP Report 350.”

The following guidance for bridge railings is documented in the TxDOT Bridge Railing Manual, Chapter 5, Section 2, Bridge Railing for Pedestrians (29).

- “Combination railing is designed for use on the outside of raised sidewalks when no separator railing is used on a facility with design speeds of 45 mph (72 km/hr) or less. It is sometimes used, though not typically required, as a separator railing between traffic on a high- or low-speed facility and an at-grade sidewalk.”
- “Railing for pedestrian-only bridges in Texas must comply with the geometry and strength requirements of current AASHTO Bridge Design Specifications.”

The following guidance for bridge railings is documented in the TxDOT Bridge Railing Manual, Chapter 5, Section 3, Bridge Railing for Bicyclists (29).

- “Texas has adopted the AASHTO Bridge Design Specifications requirement that railing of bridges that are designated for bicycle traffic should be a minimum of 54 inches (1372 mm) high...”.

3.7.3 Bridge Railing End Treatments

The following guidance for bridge railing end treatments is documented in the TxDOT Bridge Railing Manual, Chapter 5, Section 2, Bridge Railing for Pedestrians (29).

- “When using a separator railing, attach a metal-beam guard fence and terminate it at the end of the roadway shoulder, letting pedestrians walk behind the guard fence.”
- “If needed, a crash cushion can be used to absorb railing end impact energy.”

The following guidance for bridge railing end treatments is documented in the TxDOT Roadway Design Manual, Appendix A, Section 2, Barrier Need (30).

- “Where the prescribed length of the guardrail cannot be installed at a bridge end due to an intervening access point such as an intersecting roadway or driveway, the length of guardrail may be interrupted or reduced. Alternative treatments in these situations include wrapping the guardrail around the radius of the access location, terminating the guardrail prior to the access location with an appropriate end treatment and continuing the guardrail beyond the access location if necessary or using an alternate bridge end treatment.”

3.7.4 Curbs

The following guidance for curbs is documented in the TxDOT Bridge Railing Manual, Chapter 5, Section 2, Bridge Railing for Pedestrians (29).

- “A curb will adversely affect the performance of a barrier terminal.”

The following guidance for curbs is documented in the TxDOT Roadway Design Manual, Chapter 2, Section 6, Curb and Curb and Gutters (30).

- “Curb designs are classified as vertical or sloping. Vertical curbs are defined as those having a vertical or nearly vertical traffic face 6 inches (152 mm) or higher. Vertical curbs are intended to discourage motorists from deliberately leaving the roadway. Sloping curbs are defined as those having a sloping traffic face 6 inches (152 mm) or less in height. Sloping curbs can be readily traversed by a motorist when necessary.”
- “Curbs are used primarily on frontage roads, crossroads, and low-speed streets in urban areas. They should not be used in connection with the through, high-speed traffic lanes or ramp areas except at the outer edge of the shoulder where need for drainage, in which case they should be of the sloping type.”

The following guidance for curbs is documented in the TxDOT Roadway Design Manual, Appendix A, Section 4, Placement of Guardrail (30).

- “Guardrail placed in the vicinity of curbs should be blocked out so that the face of curb is located directly below or behind the face of rail.”
- “To preclude vaulting or impacting at an undesirable position by errant vehicles, care should be exercised in selecting placement location of guardrail with respect to slope conditions. Guardrail may be placed at any lateral location on a side slope only if the slope rate between the edge of the pavement and the face of the barrier is 1:10 or flatter.”

4 FIELD INVESTIGATION

4.1 Introduction

A field investigation was undertaken in order to locate sites that exhibit various methods of providing pedestrian protection on bridges. The bridge sites that were identified in this field investigation have been categorized by two main criteria. The first criteria deals with the presence or absence of a physical barrier between the vehicle and pedestrian lanes. The second criteria deals with the available approach length at the end of the bridge system. The term “unlimited approach length” is used herein to describe the situation where there is effectively unlimited space at the end of the bridge system. In this case, the designer has the freedom to choose which type of bridge rail end treatment to specify. Conversely, the term “limited approach length” is used to describe those situations where limited space at the end of the bridge system constrains the designer with regard to which type of bridge rail end treatment will be used. Approach length is determined by geometric site constraints and land use in the vicinity of the bridge. Examples of these site constraints include the existence of intersecting roadways, streets, or driveways, utility poles, fire hydrants, or other pre-existing roadside hardware at the site. Following is a summary of relevant field sites that were investigated.

4.2 No Barrier Separation - Unlimited Approach Length

4.2.1 Transitions, Guardrails, and Terminals

The bridge site shown in Figure 7 has no barrier separation and unlimited approach length. The bridge railing, which is placed on the outer edge of the sidewalk, is a combination railing for containment of both vehicular and pedestrian/bicycle traffic. The end of the bridge railing is protected by a W-beam approach guardrail transition system, a length of W-beam guardrail, and an



Figure 7. No Barrier Separation - Unlimited Approach Length - Transitions, Guardrails, and Terminals

energy-absorbing guardrail end terminal. The sidewalk is raised relative to the bridge deck and incorporates a curb and gutter between the sidewalk and traffic lanes. A mountable curb is used adjacent to the sidewalk on the bridge approach, and a steep faced barrier curb is used on the bridge itself. In both cases, the curb is intended to delineate the sidewalk and traffic lanes, as well as to facilitate roadway drainage.

4.3 No Barrier Separation - Limited Approach Length

4.3.1 Curbs and Buffer Zones

The bridge site shown in Figure 8 has no barrier separation and limited approach length. This particular site utilizes a curb and buffer zone to separate and delineate 88 km/hr traffic lanes and the pedestrian walkway. The bridge railing, which is placed on the outer edge of the sidewalk, is a combination railing for containment of both vehicular and pedestrian/bicycle traffic. Due to the extremely limited approach length at this site, the bridge railing end is not protected with an end treatment. The 3,050-mm wide sidewalk is directly adjacent to the bridge railing. A buffer zone, comprised of textured, architectural pavement, is then located adjacent to the sidewalk and on the traffic side. The buffer zone and sidewalk are both raised relative to the bridge deck by a barrier curb. The barrier curb is intended to delineate the edge of the vehicular traffic lanes. The textured pavement in the buffer zone is intended to discourage pedestrian use and increase the horizontal separation distance between vehicles and pedestrians.

4.4 Barrier Separation Provided - Unlimited Approach Length

4.4.1 Crash Cushions

The bridge site shown in Figure 9 has barrier separation and unlimited approach length. The bridge rail is a New Jersey-shape concrete barrier with an attached pedestrian/bicycle railing along



Figure 8. No Barrier Separation - Limited Approach Length - Curbs and Buffer Zones



Figure 9. Barrier Separation Provided - Unlimited Approach Length - Crash Cushions

the top edge. A pedestrian/bicycle railing is located on the opposite side of the sidewalk and on the outermost edge of the bridge. The bridge rail end is protected by an energy-absorbing crash cushion, which in this case is damaged. The sidewalk shifts laterally away from the roadway and the crash cushion near the bridge end. The approach sidewalk is elevated by a mountable curb, which terminates just upstream of the end of the crash cushion. The crash cushion is mounted flush with the roadway, and the sidewalk adjacent to the crash cushion tapers gradually to the base of the crash cushion. This configuration places the gutter line at the base of the crash cushion without the use of a curb, and it keeps water from draining onto the sidewalk. Note that even though there is unlimited approach length, the crash cushion does not appear to provide adequate length-of-need to protect traffic from the drop-off hazard behind the bridge rail.

4.4.2 Sloped Concrete End Terminal

The bridge site shown in Figure 10 has barrier separation and unlimited approach length. The bridge rail is a New Jersey-shaped concrete barrier which has a pedestrian/bicycle railing along the top edge. There is a second pedestrian/bicycle railing located on the opposite side of the sidewalk. The concrete barrier is terminated with a sloped-concrete end treatment that transitions smoothly to the mountable curb that exists on the approach roadway. The sidewalk behind the barrier shifts away from the roadway in order to increase the horizontal separation distance between traffic and pedestrians at the end of the bridge. Again, even though there are no site restrictions, the barrier that is used to separate pedestrians and traffic does not appear to provide adequate length-of-need to shield the drop-off hazard behind the barrier.

4.4.3 Transitions, Guardrails, and Terminals

The first bridge site, as shown in Figure 11, has barrier separation and unlimited approach



Figure 10. Barrier Separation Provided - Unlimited Approach Length - Sloped Concrete End Terminal



Figure 11. Barrier Separation Provided - Unlimited Approach Length - Transitions, Guardrails, and Terminals

length. A vertical concrete parapet is used to separate the pedestrian sidewalk from the 64 km/hr vehicle lanes, and a pedestrian/bicycle railing is placed along the top edge. At the end of the bridge, the sidewalk shifts laterally away from the roadway to increase the distance separating the traffic types, as well as to move the pedestrians clear of the flared guardrail and guardrail end terminal. The bridge rail end is protected by a thrie beam approach guardrail transition and a flared W-beam guardrail which is terminated using a guardrail end treatment. Present on the approach roadway is a mountable S-shaped curb which transitions to a triangular-shaped lip curb upstream from the guardrail end terminal. The lip curb is present beneath the guardrail and approach guardrail transition until its junction with the base of the bridge rail. The elevation of the sidewalk tapers to the level of the bridge deck over the length of the approach guardrail transition. The lip curb, positioned under the approach guardrail transition, tapers back to the grade of the bridge deck located behind the approach guardrail transition, thus forming a dike to prevent water runoff from flowing onto the sidewalk. Although this design appears to provide adequate length-of-need to protect motorists from the drop-off hazard behind the bridge rail, the guardrail posts are set in concrete. Crash testing has shown that setting guardrail posts in concrete reduces the redirective capacity of the barrier, and this practice should be avoided if possible.

The second bridge site, as shown in Figure 12, has barrier separation and unlimited approach length. The bridge rail is a vertical concrete parapet which has a pedestrian/bicycle railing along the top edge. A second pedestrian/bicycle railing is located on the opposite side of the sidewalk and on the outermost edge of the bridge. The bridge rail end is protected by a thrie beam approach guardrail transition and a flared W-beam guardrail which is terminated using a guardrail end treatment. At the end of the bridge, the sidewalk shifts laterally away from the roadway to increase



Figure 12. Barrier Separation Provided - Unlimited Approach Length - Transitions, Guardrails, and Terminals

the distance separating the traffic types, as well as to move the pedestrians clear of the flared guardrail and guardrail end terminal. Present on the approach roadway is a mountable S-shaped curb which transitions to a rounded lip curb at the junction of the W-beam to thrie beam transition. The entire length of the W-beam guardrail and guardrail end terminal are placed on top of and behind the mountable S-shaped curb. In addition, cutouts are provided in the sidewalk to allow the guardrail posts to rotate in the soil and maintain the barrier's redirective capacity.

In both Figures 11 and 12, the bridge rail ends are protected by thrie beam approach guardrail transitions and flared W-beam guardrails which are terminated with guardrail end treatments. However, there are some significant differences in curb placement that must be noted. The mountable S-shaped curb on the approach roadway in Figure 11 transitions to a triangular-shaped lip curb upstream of the guardrail end terminal in order to maintain drainage capacity, while minimizing the effects on the trajectory of an impacting vehicle. Alternately, the configuration shown in Figure 12, transitions from a mountable S-shaped curb to a rounded lip curb at the junction of the W-beam to thrie beam transition, thus placing the guardrail and guardrail end terminal systems directly behind the mountable S-shaped curb on the approach roadway. However, past research has shown that the crashworthiness of a guardrail system may be affected by a curb located beneath and/or in front of a barrier system (8). Therefore, it is concluded that the sites shown in Figures 11 and 12 are not equivalent in terms of crashworthiness.

4.4.4 Transitions, Guardrails, and Crash Cushions

The first bridge site incorporating an approach guardrail transition with a crash cushion for pedestrian protection, as shown in Figure 13, has barrier separation and unlimited approach length. A New Jersey-shaped concrete barrier is used to separate the pedestrian sidewalk from the 56 km/hr



Figure 13. Barrier Separation Provided - Unlimited Approach Length - Transitions, Guardrails, and Crash Cushions

vehicle lanes, and a pedestrian/bicycle railing is placed along the top edge. A second pedestrian/bicycle railing is located on the opposite side of the sidewalk and on the outermost edge of the bridge. The end of the bridge rail is protected with an approach guardrail transition, standard guardrail, and a Crash-Cushion Attenuating Terminal (CAT). The CAT is capable of providing redirection for oblique impacts, as well as absorbing energy in end-on impacts. Present on the approach roadway is a mountable S-shaped curb that transitions to a triangular-shaped lip curb at the junction of the W-beam to thrie beam transition. At the end of the bridge, the sidewalk shifts laterally away from the roadway to increase the distance separating the traffic types, as well as to move pedestrians away from the CAT system.

The second bridge site, as shown in Figure 14, has barrier separation and unlimited approach length. A New Jersey-shape concrete barrier is used to separate the pedestrian sidewalk from the 56 km/hr vehicle lanes, and a pedestrian/bicycle railing is placed along the top edge. A second pedestrian/bicycle railing is located on the opposite side of the sidewalk and on the outermost edge of the bridge. The end of the bridge rail is protected with an approach guardrail transition, standard guardrail, and a CAT system. Present on the approach roadway is a mountable S-shaped curb that remains present beneath the approach guardrail transition, standard guardrail, and CAT system until its junction with the base of the bridge railing. At the end of the bridge, the sidewalk shifts laterally away from the roadway to increase the distance separating the traffic types and also to move pedestrians away from the CAT system.

Both Figures 13 and 14 display sites that utilize CAT systems to protect the bridge rail ends. As before, there are some significant differences in curb placement must be noted. The curb on the approach roadway in Figure 13 transitions to a triangular-shaped lip curb at the junction of the



Figure 14. Barrier Separation Provided - Unlimited Approach Length - Transitions, Guardrails, and Crash Cushions

W-beam to thrie beam transition. The full height of the S-shaped curb along the approach roadway is maintained under the transition section shown in Figure 14. The CAT systems in both cases are placed on top of and behind the mountable S-shaped curb on the approach roadway. However, past research has shown that the crashworthiness of a guardrail system may be affected by a curb located beneath and/or in front of a barrier system (8). Therefore, it is concluded that the sites shown in Figures 13 and 14 are not equivalent in terms of crashworthiness.

4.5 Barrier Separation Provided - Limited Approach Length

4.5.1 Sloped Concrete End Terminal

The bridge site shown in Figure 15 has a barrier separating pedestrians and 72 km/hr traffic lanes with an extremely limited approach length. The concrete bridge rail is a New Jersey-shaped barrier with a pedestrian railing mounted along the top edge. A second pedestrian/bicycle railing is located on the opposite side of the sidewalk and on the outermost edge of the bridge. The end of the bridge rail is protected by a sloped concrete end terminal which tapers and transitions with the curb line directly upstream of the bridge railing. The pedestrian sidewalk is raised relative to the bridge deck. This design does not appear to provide adequate length-of-need to protect traffic from the drop-off hazard behind the bridge rail.

4.5.2 Short Radius Guardrail

The first bridge site utilizing short radius guardrail, as shown in Figure 16, has a barrier separating pedestrians and 64 km/hr traffic lanes, along with limited approach length due to its close proximity to an intersecting street. The bridge rail is a vertical concrete parapet with a pedestrian/bicycle railing along the top edge. A second pedestrian/bicycle railing is located on the opposite side of the sidewalk and on the outermost edge of the bridge. A short radius guardrail



Figure 15. Barrier Separation Provided - Limited Approach Length - Sloped Concrete End Terminal



Figure 16. Barrier Separation Provided - Limited Approach Length - Short Radius Guardrail

system is used to shield the bridge rail end, to protect the pedestrians on the sidewalk, and to aid in shielding the obstacle behind the bridge rail. A three beam approach guardrail transition is used between the concrete bridge railing and the W-beam guardrail section of the short radius guardrail. The W-beam guardrail turns the corner and terminates adjacent to the intersecting roadway. The pedestrian sidewalk follows along the backside of the guardrail system and beyond the terminal end. At this location, a pedestrian crosswalk is provided which traverses the roadway. Because the sidewalk is at grade with the bridge deck, a concrete dike is located under the approach guardrail transition and short radius guardrail systems in order to divert water runoff away from the sidewalk.

The second bridge site, as shown in Figure 17, has barrier separation between pedestrians and 56 km/hr traffic lanes, along with limited approach length. A short radius guardrail system, similar to site no. 1, is used to shield the bridge rail end, to protect the pedestrians on the sidewalk, and to aid in shielding the obstacle behind the bridge rail. Unlike site no. 1, a mountable S-shaped curb is installed flush with the face of the W-beam guardrail and transitions to a triangular-shaped lip curb under the three beam transition section.

The third and final bridge site, as shown in Figure 18, has barrier separation between pedestrians and vehicular traffic lanes, along with limited approach length. A short radius guardrail system, similar to site nos. 1 and 2, is used to shield the bridge rail end, to protect the pedestrians on the sidewalk, and to aid in shielding the obstacle behind the bridge rail. Unlike site nos. 1 and 2, the bridge rail does not have a pedestrian/bicycle railing along the top edge. This system is mounted flush with the roadway, and no curbs are present on the bridge approach nor along the approaching roadway.



Figure 17. Barrier Separation Provided - Limited Approach Length - Short Radius Guardrail



Figure 18. Barrier Separation Provided - Limited Approach Length - Short Radius Guardrail

The three short radius guardrail sites, as shown in Figures 16 through 18, appear to be very similar in their design intent and construction. However, there are some significant differences in curb placement that must be noted. Site no. 2, as illustrated in Figure 17, has a curb flush with the face of the short radius guardrail system, while site no. 3, as shown in Figure 18, does not have a curb present at all. Past research has shown that the crashworthiness of a guardrail system may be affected by a curb located beneath or in front of a barrier system (8). Therefore, it is concluded that the sites shown in Figures 17 and 18 are not equivalent in terms of crashworthiness.

It is also worthy to note that differences exist in hydraulic drainage capability at all three sites. Site no. 1, as shown in Figure 16, has the pedestrian walkway placed at the grade of the bridge deck. A variable height concrete dike is placed between the sidewalk and the vehicle lanes to prevent roadway water runoff from draining across the sidewalk. The sidewalk at site no. 2, as shown in Figure 17, is elevated relative to the bridge deck surface. This change in grade prevents roadway water runoff from draining across the sidewalk. Finally, site no. 3, as shown in Figure 18, incorporates no measures to keep roadway water runoff from draining across the sidewalk. Because roadway drainage can contribute to water ponding, debris accumulation, and ice formation on the pedestrian walkway, it is concluded that these three sites are not equivalent in terms of pedestrian safety.

5 BRIDGE RAIL END TREATMENT CONFIGURATIONS

5.1 Introduction

The research previously conducted has helped to identify the most common scenarios in which the protection of pedestrians on bridges is desirable. It has also defined the range of problems and conditions that must be addressed within this study. The recommended solutions outlined herein have been categorized by two main criteria. The first criteria deals with the presence or absence of a physical barrier between the vehicle and pedestrian lanes. The second criteria deals with the available approach length at the end of the bridge system.

Combination vehicle/pedestrian and vehicle/bicycle railings are used on bridges which carry both vehicular and pedestrian/bicycle traffic and are designed to provide redirection capabilities and containment for the vehicles traversing the bridge. These combination railings are commonly incorporated into the bridge design using two basic configurations. For the first configuration, these combination railings are installed at the outermost edge of the bridge structure. In these cases, the pedestrian and bicycle pathways are located directly adjacent to the vehicle lanes and are often placed on a raised sidewalk located on the traffic-side face of the bridge railing. Throughout this report, this situation will be referred to as “no barrier separation.” For the second configuration, these combination railings are placed between the vehicle and pedestrian/bicycle lanes in order to shield the pedestrians and bicyclists from errant vehicles that may leave the traveled way. In these cases, a second pedestrian/bicycle railing must be located on the opposite side of the pathway and along the edge of the bridge structure. Within this report, this situation will be referred to as “barrier separation provided.” However, if barrier separation is provided between the vehicle and bicycle lanes, additional consideration should be given to ensure that the back side of the combination

railing is free from protruding posts that may pose a snagging hazard to bicyclists.

The term “unlimited approach length” is used herein to describe the situation where there is effectively unlimited space at the end of the bridge system, thus allowing the designer the freedom to choose which type of bridge rail end treatment will be implemented. And conversely, the term “limited approach length” is used to describe those situations where limited space at the end of the bridge system constrains the designer with regard to which type of bridge rail end treatment can be installed. Approach length is determined by geometric site constraints and land use in the vicinity of the bridge. Examples of these site constraints might include the existence of intersecting roadways, streets, or driveways, utility poles, fire hydrants, or other pre-existing roadside hardware. It is noted that situations with limited approach length must not compromise the length of need required for the proper placement of the safety barrier. The length of need is defined in the AASHTO’s *Roadside Design Guide* (6) as the length of barrier required to fully protect the hazard located behind the barrier.

Within this chapter, the bridge rail end treatment configurations have been separated into two main categories: “No Barrier Separation” and “Barrier Separation Provided”. These two main categories have been further divided according to the site constraints: “Unlimited Approach Length” and “Limited Approach Length”. Within each of these categories, configurations for treating bridge rail ends have been detailed according to a specific roadside hardware type, such as crash cushions or short radius guardrails.

5.2 No Barrier Separation

In some situations, adequate pedestrian safety can be provided on bridges by creating a walkway that is adjacent to the vehicle traffic lanes without the use of a physical barrier. An

example of a combination vehicle/pedestrian railing placed on an elevated sidewalk is shown in Figure 19. AASHTO's *LRFD Bridge Design Specifications* recommends the use of a combination vehicle/pedestrian railing adjacent to a raised sidewalk on roadways designed for 72 km/hr or less (3). However, it is worthy to note that curbs are generally incapable of shielding the pedestrians traversing elevated sidewalks on bridges, but rather curbs provide delineation between the sidewalk and the traveled way discouraging the mingling of the traffic types. Furthermore, past research has shown that the crashworthiness of a guardrail system may be affected by a curb located beneath and/or in front of a barrier system (8).

Refer to Sections 2.2.2, 2.3, and 2.5 for a comprehensive summary of the current existing guidelines concerning the protection of pedestrians using barrier separation.

5.2.1 Curbs, Placebo Barriers, and Buffer Zones

One major aspect of this study focused on curbs used in conjunction with bridge rail end treatments. To date, there have been no published crash testing efforts performed on guardrail terminals and crash cushions installed over curbs according to the NCHRP Report No. 350 safety standards. Also, there has been very limited successful testing of approach guardrail transitions and guardrail systems installed over curbs (10-14). As such, this study makes recommendations on curb configurations and their placement relative to crashworthy roadside safety hardware based on the following considerations:

- (1) the use of curb/barrier configurations evaluated according to the NCHRP Report No. 350 safety standards;
- (2) the use of curb/barrier configurations that minimize the potential for safety concerns based on prior research and sound engineering judgement; and
- (3) the use of curb/barrier configurations that historically have been shown to provide adequate safety performance in the field.

Notes:

1. All dimensions shown in mm.

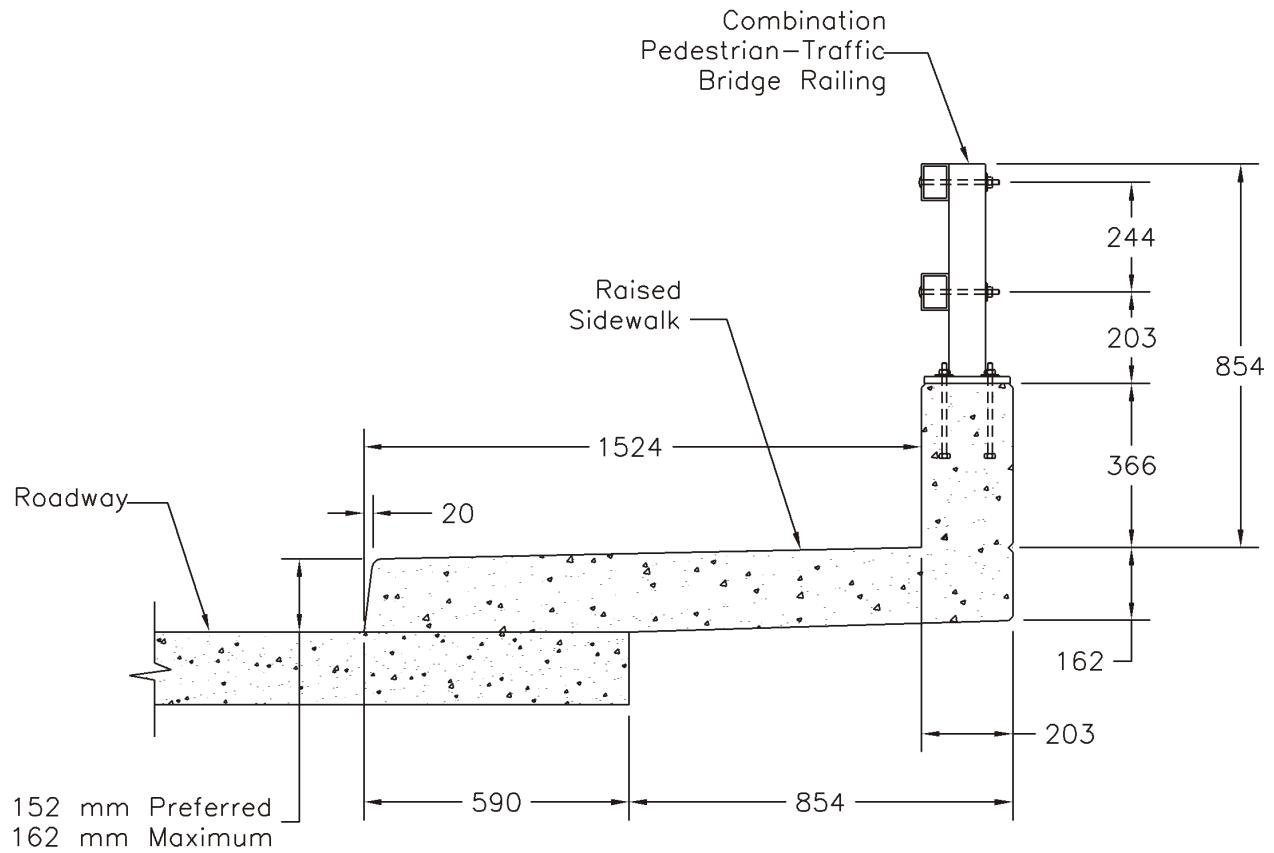

Figure 19. Typical Raised Sidewalk with Combination Vehicle/Pedestrian Bridge Railing (3, 16)

The general cases illustrated herein take into consideration the fact that curbs are present on the approaching roadways for controlling drainage or for other purposes. If curbs are not present or drainage is handled in an alternative manner, it is assumed that crashworthy roadside hardware, at the test level of the roadway in question, is placed at the end of the bridge railing and that the pedestrians and bicyclists have been appropriately accommodated.

The results of NCHRP Report No. 150, *The Effect of Curb Geometry and Location on Vehicle Behavior* (8), were previously noted and are reiterated here for clarity. The potential for vehicular vaulting and/or snagging of barriers following an impact with curbs was demonstrated under various speeds and impact conditions. The possible trajectory of a vehicle's bumper with respect to a guardrail system placed adjacent to or behind a curb following a vehicular impact with a curb is illustrated in Figure 1(9). In general, prior research has shown that roadside barriers may perform inadequately when placed over the top of curbs, and curbs used for delineation do not have the ability to adequately redirect an errant vehicle. As a result, the physical protection of pedestrians and bicyclists on bridges, as well as near the bridge approach, may be compromised due to the presence of curbs (8).

A curb is sometimes called a placebo barrier because curbs, even barrier curbs, are inadequate for preventing a vehicle from leaving the roadway (2). A buffer zone is simply a region of lateral space placed between the vehicle lanes and the walkway. A curb and buffer zone combination can also be placed between the vehicle and pedestrian lanes in order to clearly delineate the separation of lane types as well as to provide increased recovery distance for the drivers of errant vehicles. Both buffer zones and placebo barriers are intended to not only improve the safety of the pedestrian but to also increase the pedestrian's perceived level of safety. A typical example of the

use of curbs, placebo barriers, and buffer zones placed on a bridge and with unlimited approach length is provided in Figure 20. Curbs, placebos, and buffer zones may be beneficial when used in conjunction with other bridge rail end treatments, as well as in situations with limited approach length.

5.2.2 Unlimited Approach Length

The ideal case for designers is a bridge site with ample approach length and lateral width to accommodate both vehicular traffic and pedestrian/bicycle safety features. In this situation, designers can freely specify appropriate pedestrian/bicycle safety facilities as well as bridge railing end treatments without being forced to make compromises based on geometrical site constraints.

5.2.2.1 Transitions, Guardrails, and Terminals

A scenario with no barrier separation and unlimited approach length is illustrated in Figure 21. The ends of the bridge railing can be protected with either a TL-2, TL-3, or TL-4 approach guardrail transition, strong-post guardrail, and guardrail end terminal. As shown in Figure 21, the pedestrians and/or bicyclists are placed on pathways located on the traffic-side face of both the bridge rail and guardrail systems, and a curb is placed at the edge of the traveled way.

For this scenario, two key points need to be addressed. First, in this situation, the pedestrians and bicyclists positioned on the pathway are inherently at greater risk than if they were located behind the barrier systems. This is due to the fact that they remain closer to the traveled way and are unshielded from errant vehicles leaving the roadway. Therefore, research engineers as well as bridge and roadway engineers must determine what increased levels of safety can be achieved when separation is provided between the motorists and pedestrians. Most likely, a benefit-to-cost ratio or cost-effectiveness analysis will be required in order to make this determination.

Notes:

- 1 Curb (placebo barrier) and buffer zone provided – walkway/pathway on front side of bridge rail.
- 2 Adequate approach length available for standard guardrail system.
- 3 FHWA approved TL-2, TL-3, or TL-4 approach guardrail transitions, guardrails, and guardrail end terminals.
- ④ Bridge rail or combination of bridge rail, approach guardrail transition, and strong-post guardrail may be used to protect the hazard behind the bridge rail. However, consideration must be given to the test-level rating of the roadside hardware associated with the required length-of-need.
- ⑤ Further research is required in order to determine appropriate, safe placement of curbs relative to bridge rails, approach guardrail transitions, guardrails, guardrail terminals, and crash cushions.
- ⑥ Increased buffer zone width may be beneficial for increased pedestrian protection where space is available.

62

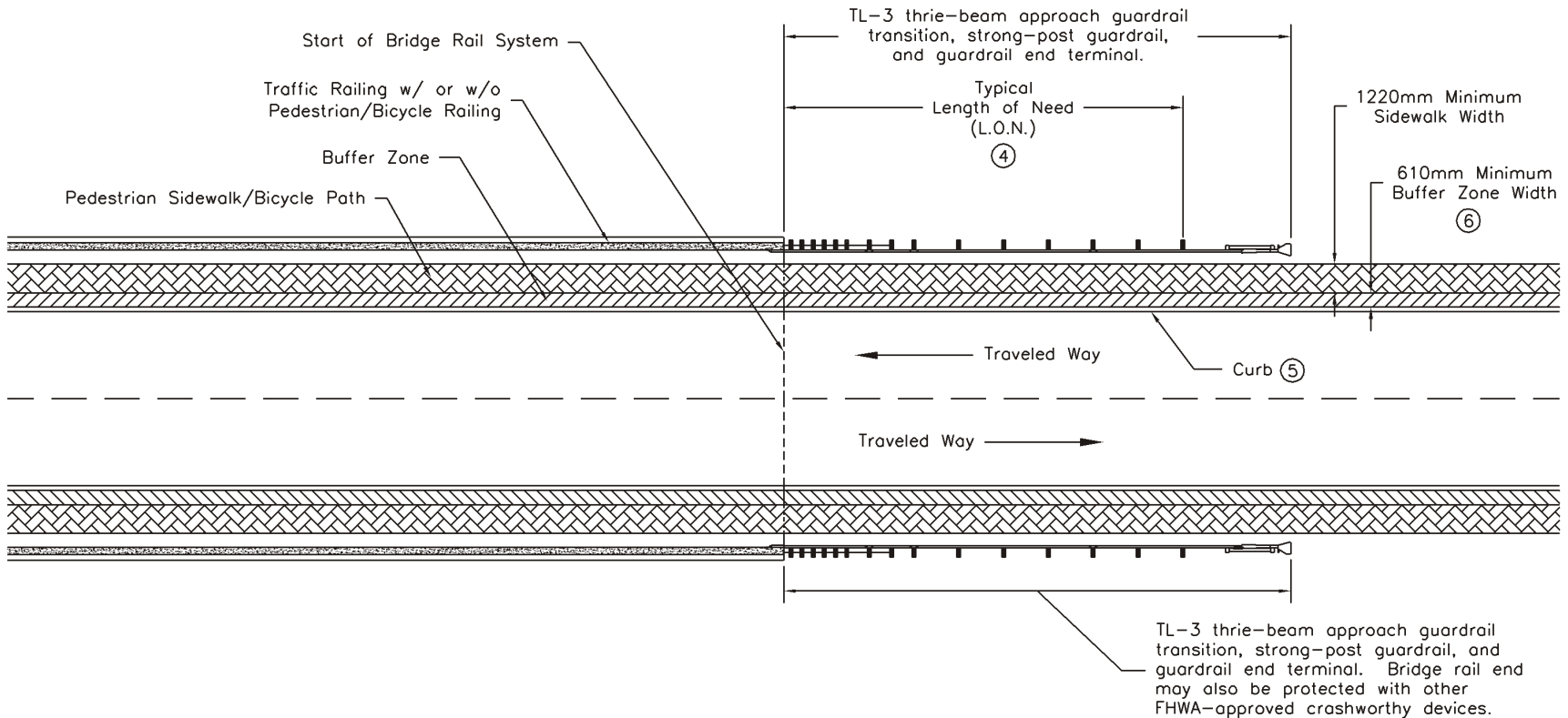

Figure 20. No Barrier Separation - Unlimited Approach Length - Curbs, Placebo Barriers, and Buffer Zones

Notes:

- 1 No barrier separation provided – walkway/pathway on front side of bridge rail.
- 2 Adequate approach length available for standard guardrail system.
- 3 FHWA approved TL-2, TL-3, or TL-4 approach guardrail transitions, guardrails, and guardrail end terminals.
- ④ Bridge rail or combination of bridge rail, approach guardrail transition, and strong-post guardrail may be used to protect the hazard behind the bridge rail. However, consideration must be given to the test-level rating of the roadside hardware associated with the required length-of-need.
- ⑤ Further research is required in order to determine appropriate, safe placement of curbs relative to bridge rails, approach guardrail transitions, guardrails, guardrail terminals, and crash cushions.

63

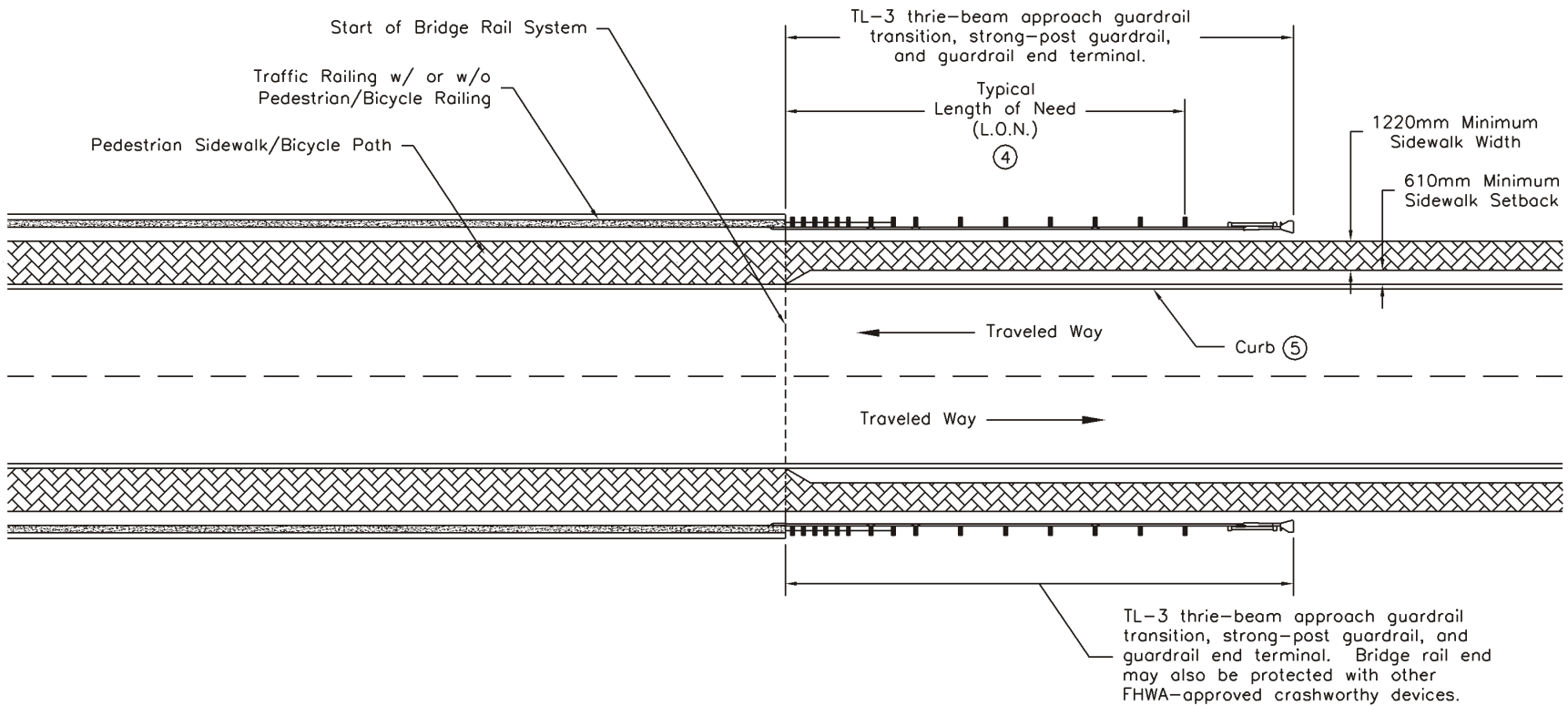

Figure 21. No Barrier Separation - Unlimited Approach Length - Transitions, Guardrails, and Terminals

Second, past research has shown that curbs placed in front of or below guardrail systems may result in vaulting or underride of the barrier as well as vehicular instabilities. Therefore, bridge and roadway engineers should review the standard of practice on curb/barrier combinations and proceed with caution when implementing their use in pedestrian facilities located on or near bridges. However, it should also be noted that future research is required in order to determine the appropriate placement of curbs relative to bridge rails, approach guardrail transitions, guardrails, guardrail terminals, and crash cushions.

5.2.2.2 Crash Cushions

A second scenario with no barrier separation and unlimited approach length is illustrated in Figure 22. In this case, the bridge rail ends are protected with either a TL-2 or TL-3 energy-absorbing crash cushion. As shown in Figure 22, the pedestrian and/or bicyclist pathways are located on the traffic-side face of both the bridge rail and crash cushion systems, and a curb is placed at the edge of the traveled way. Additional discussion on the positioning of the pathways and the curbs is the same as that provided in Section 5.2.2.1.

5.2.2.3 Evaluation - No Barrier Separation, Unlimited Approach Length

Three methods for providing pedestrian protection on bridges where there exists unlimited approach length at the site and barrier separation is not provided have been illustrated in Figures 20 through 22. The roadside hardware utilized at all three sites is equivalent in terms of basic crashworthiness since all hardware has been crash tested according to the NCHRP Report No. 350 impact safety standards. However, it must be noted that placement of these barriers relative to curbs greatly affects crashworthiness due to the potential for vehicular vaulting of the barrier under certain impact conditions. Therefore, further research is required in order to determine the appropriate, safe

Notes:

- 1 No separation provided – walkway/pathway on front side of bridge rail.
- 2 Adequate approach length available for standard guardrail system.
- 3 FHWA approved TL-2 or TL-3 crash cushions.
- ④ Bridge rail or combination of bridge rail and crash cushion may be used to protect the hazard behind the bridge rail. However, consideration must be given to the test-level rating of the roadside hardware associated with the required length-of-need.
- ⑤ Further research is required in order to determine appropriate, safe placement of curbs relative to bridge rails, approach guardrail transitions, guardrails, guardrail terminals, and crash cushions.

65

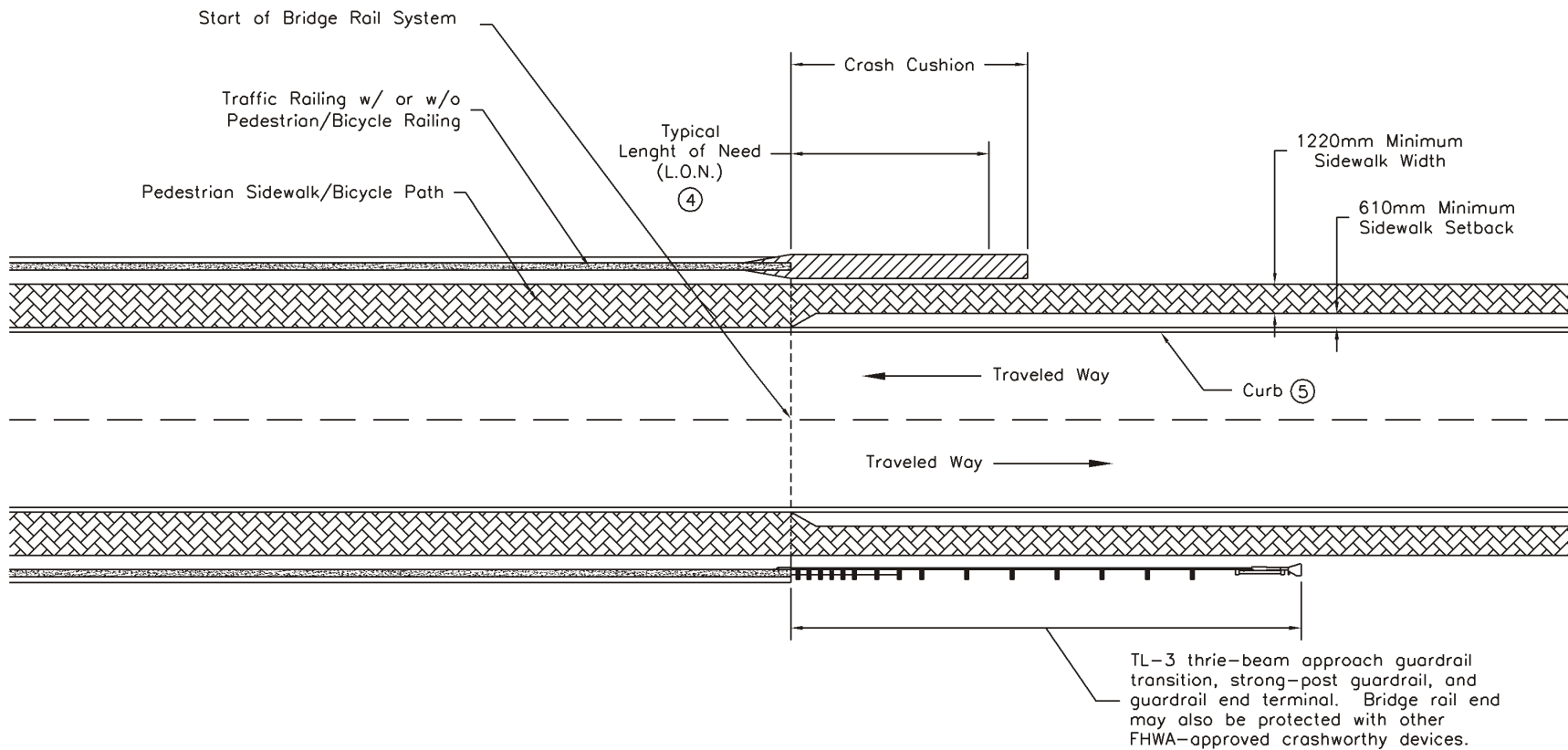

Figure 22. No Barrier Separation - Unlimited Approach Length - Crash Cushions

placement of curbs in these situations. In cases where additional buffer zone width is used to increase lateral separation between the pedestrian walkway and traffic lanes, Figure 20 may provide the highest level of safety to pedestrians. Increased buffer zone width may also help to stabilize the vehicle prior to impact with the barrier, thus improving the crashworthiness of the barrier when located behind the curb.

5.2.3 Limited Approach Length

Bridge sites with limited approach length will not allow the use of conventional approach guardrail transitions, standard guardrail, and guardrail end terminals. In these situations, the designer is forced to specify alternative bridge rail end treatments that appropriately satisfy the safety requirements of the site.

5.2.3.1 Crash Cushions

A scenario that has no barrier separation and limited approach length is illustrated in Figure 23. In this case, the bridge rail ends are protected with either a TL-2 or TL-3 energy-absorbing crash cushion. A crash cushion is used in place of typical approach guardrail transitions, standard guardrails, and guardrail end terminals due to the close proximity of an intersecting roadway, street, or driveway on the approach side of the bridge. As shown in Figure 23, the pedestrian and/or bicyclist pathways are located on the traffic-side face of both the bridge rail and crash cushion systems, and a curb is placed at the edge of the traveled way. Additional discussion on the positioning of the pathways and the curbs is the same as that provided in Section 5.2.2.1.

5.2.3.2 Short Radius Guardrails

A second scenario that has no barrier separation and has limited approach length is shown in Figure 24. In this case, the bridge rail ends are protected by a short radius guardrail system. The

Notes:

- 1 No barrier separation provided – walkway/pathway on front side of bridge rail.
- 2 Approach length is limited.
- 3 FHWA approved TL-2 or TL-3 crash cushions.
- ④ Bridge rail or combination of bridge rail and crash cushion may be used to protect the hazard behind the bridge rail. However, consideration must be given to the test-level rating of the roadside hardware associated with the required length-of-need.
- ⑤ Further research is required in order to determine appropriate, safe placement of curbs relative to bridge rails, approach guardrail transitions, guardrails, guardrail terminals, and crash cushions.

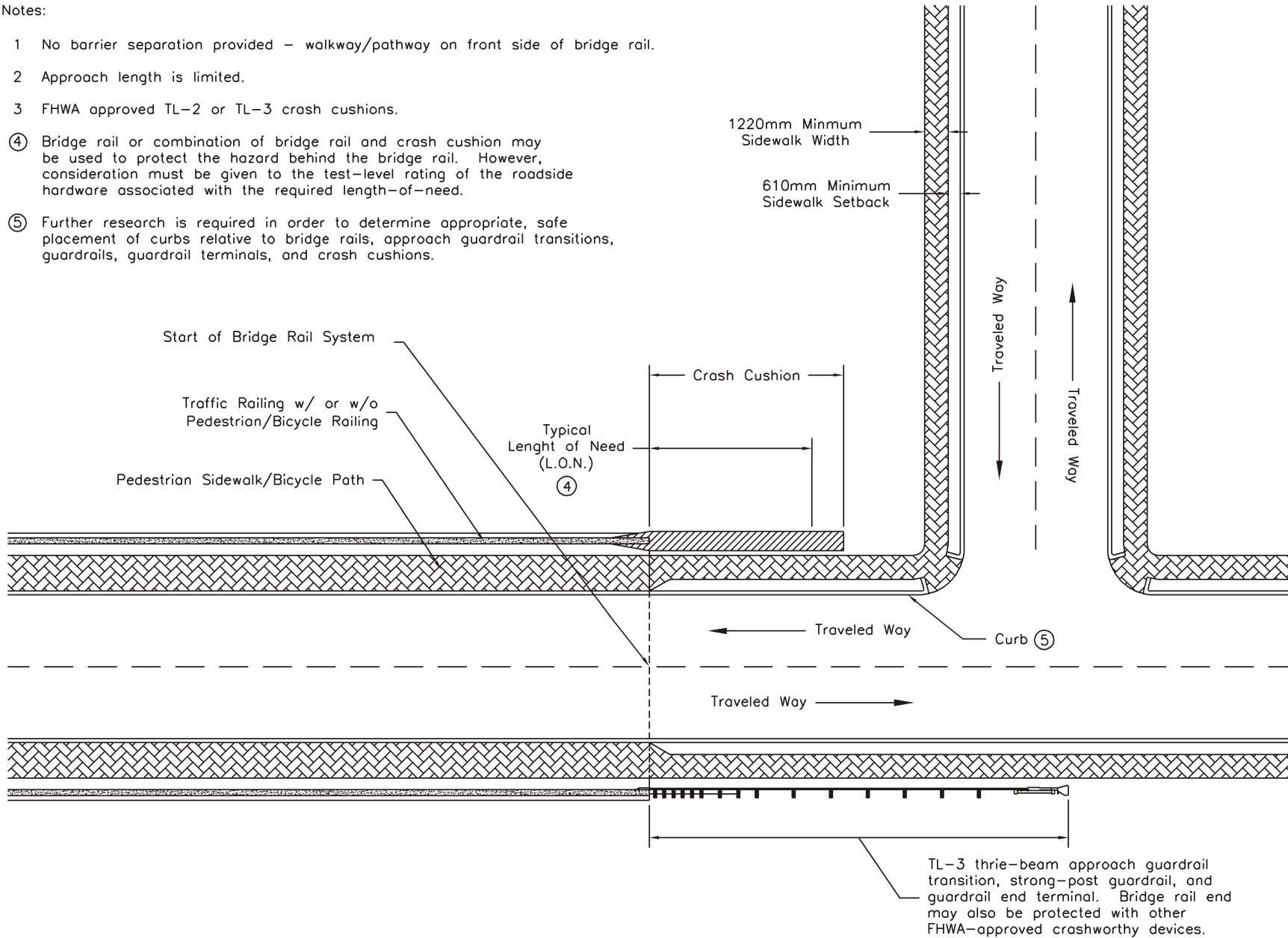

Figure 23. No Barrier Separation - Limited Approach Length - Crash Cushions

short radius guardrail system is provided for situations where typical bridge rail end treatments cannot be used due to the close proximity of an intersecting roadway, street, or driveway. The guardrail section of the barrier curves around the corner and maintains a position behind the pedestrian walkway. At this location, the guardrail is terminated by a standard guardrail end terminal. As shown in Figure 24, the pedestrian and/or bicyclist pathways are located on the traffic-side face of both the bridge rail and short radius guardrail system, and a curb is placed at the edge of the traveled way. Additional discussion on the positioning of the pathways and the curbs is the same as that provided in Section 5.2.2.1.

Finally, it should be noted that this short radius guardrail system is currently under development and has not met the NCHRP Report No. 350 safety standards. However, it has been included herein since it may in the future provide a viable alternative for meeting either the TL-2 or TL-3 impact safety standards.

5.2.3.3 Evaluation - No Barrier Separation, Limited Approach Length

Two methods for providing pedestrian protection on bridges where there exists limited approach length due to an intersecting street and barrier separation is not provided have been illustrated in Figures 23 and 24. Currently, there is not a short radius guardrail system approved to meet the NCHRP Report No. 350 impact safety standards. As a result, an NCHRP Report No. 350-approved crash cushion is probably the best alternative for this situation. For TL-2 applications, a short radius guardrail system approved to the impact safety standards of NCHRP Report No. 230 may be an acceptable alternative. Again, it must be noted that placement of both crash cushions and short radius barriers relative to curbs greatly affects their crashworthiness due to the potential for vehicular vaulting of the barrier. Therefore, further research is required in order to determine appropriate, safe placement of curbs near these systems.

Notes:

- 1 No barrier separation provided – walkway/pathway on front side of bridge rail.
- 2 Approach length is limited.
- 3 Short Radius Guardrails – system is currently under development.
- ④ Bridge rail or combination of bridge rail, approach guardrail transition, and strong-post guardrail may be used to protect the hazard behind the bridge rail. However, consideration must be given to the test-level rating of the roadside hardware associated with the required length-of-need.
- ⑤ Further research is required in order to determine appropriate, safe placement of curbs relative to bridge rails, approach guardrail transitions, guardrails, guardrail terminals, and crash cushions.

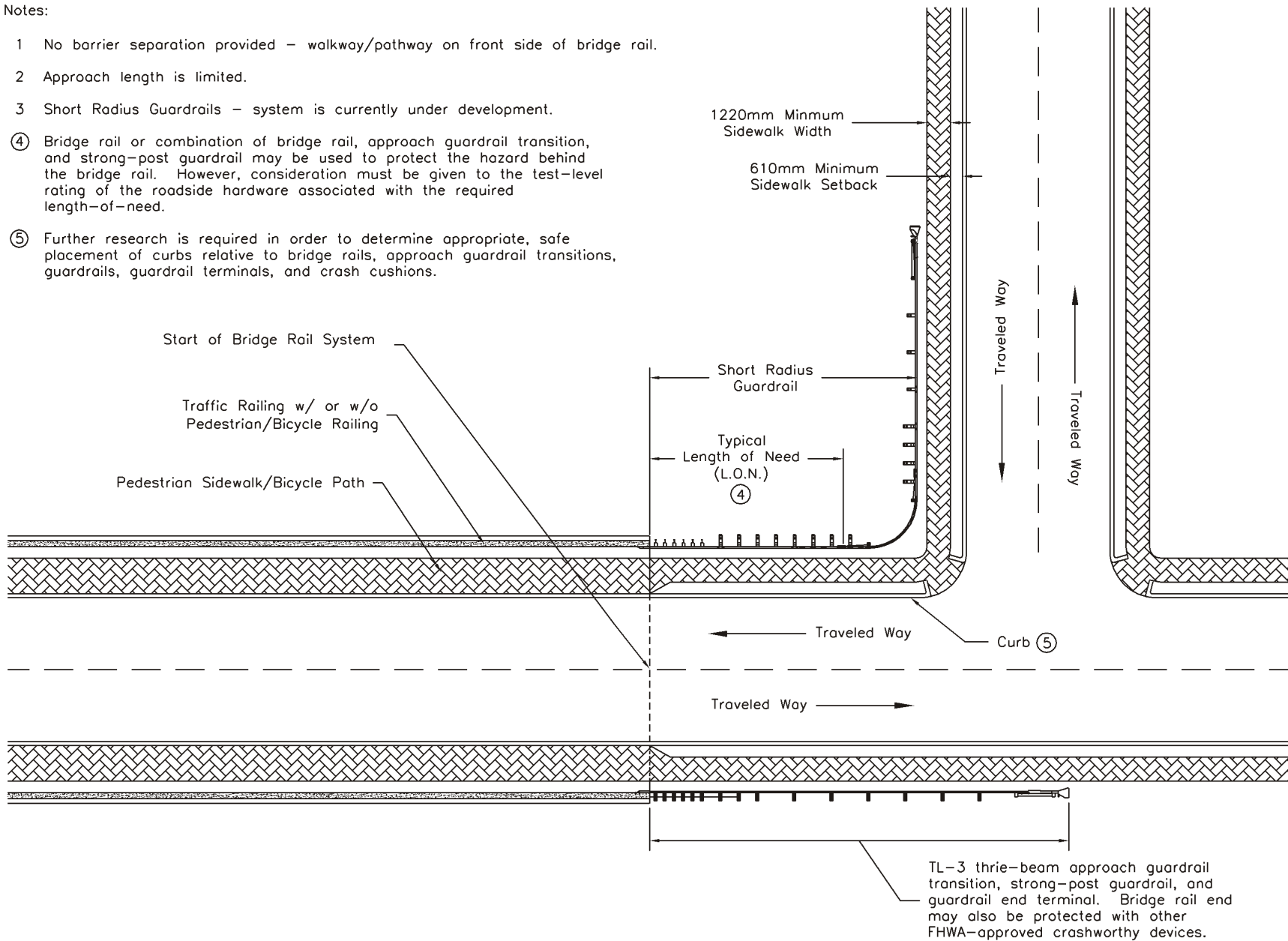

Figure 24. No Barrier Separation - Limited Approach Length - Short Radius Guardrails

5.3 Barrier Separation Provided

Pedestrian safety on bridges is maximized when the vehicle and pedestrian lanes are separated with either an NCHRP Report No. 350-approved bridge railing, a combination vehicle/pedestrian bridge railing, or a combination vehicle/bicycle bridge railing (6). This physical barrier creates positive shielding of the pedestrian lanes, thereby increasing both the actual safety of the pedestrians as well as their perceived level of safety. At the bridge ends, an approved barrier end treatment must be provided in order to prevent errant motorists from impacting the barrier ends as well as to decrease the potential for vehicle snag and pocketing into a barrier system with significant changes in lateral stiffness. However, it is noted that the barrier configuration selected must also conform to the geometrical constraints of the bridge site without impeding the flow of the pedestrian and/or bicycle traffic (2).

Refer to Sections 2.2.2, 2.3, and 2.5 for a comprehensive summary of the current existing guidelines concerning the protection of pedestrians using barrier separation.

5.3.1 Unlimited Approach Length

The ideal case for designers is a bridge site with ample approach length and lateral width to accommodate both vehicular traffic and pedestrian/bicycle safety features. In this situation, designers can freely specify appropriate pedestrian/bicycle safety facilities as well as bridge railing end treatments without being forced to make compromises based on geometrical site constraints.

5.3.1.1 Transitions, Guardrails, and Terminals

A scenario that has unlimited approach length and provides barrier separation is illustrated in Figure 25. The ends of the bridge railing separating the vehicular and pedestrian/bicycle traffic can be protected with either a TL-2, TL-3, or TL-4 approach guardrail transition, strong-post

guardrail, and guardrail end terminal. If a curb is present along the upstream roadway, the curb is transitioned a swale upstream from the guardrail end terminal, as shown in Figure 26. Note that a strong post guardrail system utilizes double blockouts and a flared end terminal to improve hydraulic efficiency by moving the posts away from the gutter line. A swale is a roadside feature that provides hydraulic drainage similar to that of a curb, but unlike a standard curb, it has a flat face sloping up and away from the gutter line. Upon impact by a vehicle, this flattened face should minimize the disruption to the vehicle's trajectory, thereby greatly reducing the potential for vehicular instabilities prior to reaching the guardrail. As a result, it is believed that the use of swales will eliminate the potential for the vehicles to climb and vault over the guardrail systems.

A second scenario that has unlimited approach length, provides barrier separation, and utilizes either a TL-2, TL-3, or TL-4 approach guardrail transition, strong-post guardrail, and guardrail end terminal is shown in Figure 27. In this case, the curb is positioned behind the guardrail and guardrail end terminal, as shown in Figure 28. It is desirable for the curb to be sufficiently set back from the guardrail end terminal so that an errant vehicle will not mount the curb with the right-front tire prior to an end-on impact with the terminal's end. If the curb set-back distance is sufficient, a vehicle will impact the roadside hardware prior to mounting the curb, thus eliminating the curb's influence on the vehicle's trajectory during the impact sequence. In addition, this curb configuration shifts the gutter line behind the guardrail and guardrail end terminal, thus creating potential hydraulic problems. By forcing the gutter line to follow a path underneath and behind the guardrail, selected posts are moved to a location in front of the curb and potentially in the path of water runoff. Therefore, it is recommended that a water drain be placed immediately upstream of the gutter line shift, as shown in Figure 27. Furthermore and in order to minimize the posts' potential

Notes:

- 1 Barrier separation provided - walkway/pathway behind barrier.
- 2 Adequate approach length available for standard guardrail system.
- 3 FHWA approved TL-2, TL-3, or TL-4 approach guardrail transitions, guardrails, and guardrail end terminals.
- ④ Bridge rail or combination of bridge rail, approach guardrail transition, and strong-post guardrail may be used to protect the hazard behind the bridge rail. However, consideration must be given to the test-level rating of the roadside hardware associated with the required length-of-need.
- ⑤ Curb transitions to swale as shown.
- ⑥ Refer to Figure 26 for cross-sectional views A-A and B-B.

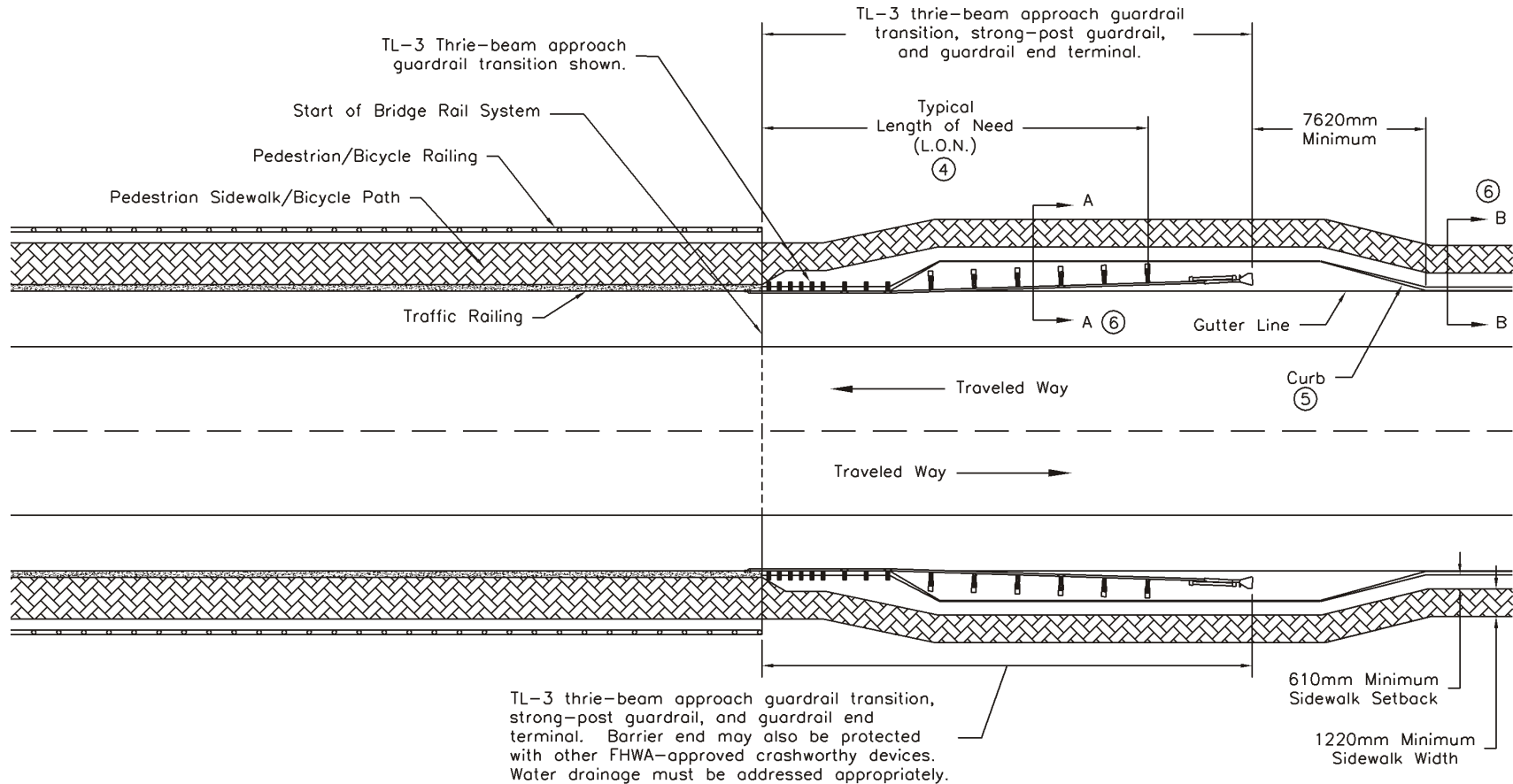

72

Figure 25. Barrier Separation Provided - Unlimited Approach Length - Transitions, Guardrails, and Terminals

Notes:

- 1 All dimensions in mm.
- 2 Upstream curb shown in Section B-B.
- 3 Curb transitions to swale with maximum slope of 10:1, as shown in Section A-A.
- 4 In order to increase hydraulic efficiency, double blockouts are used to increase offset distance between the face of the posts and the gutter line, as shown in Section A-A.

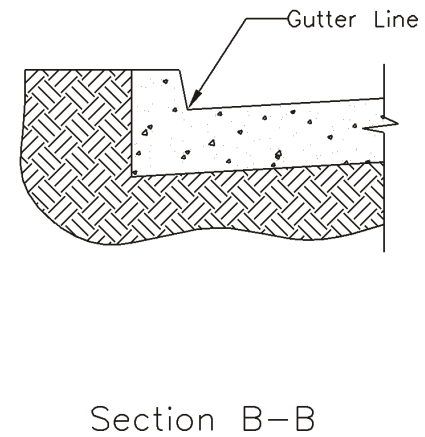
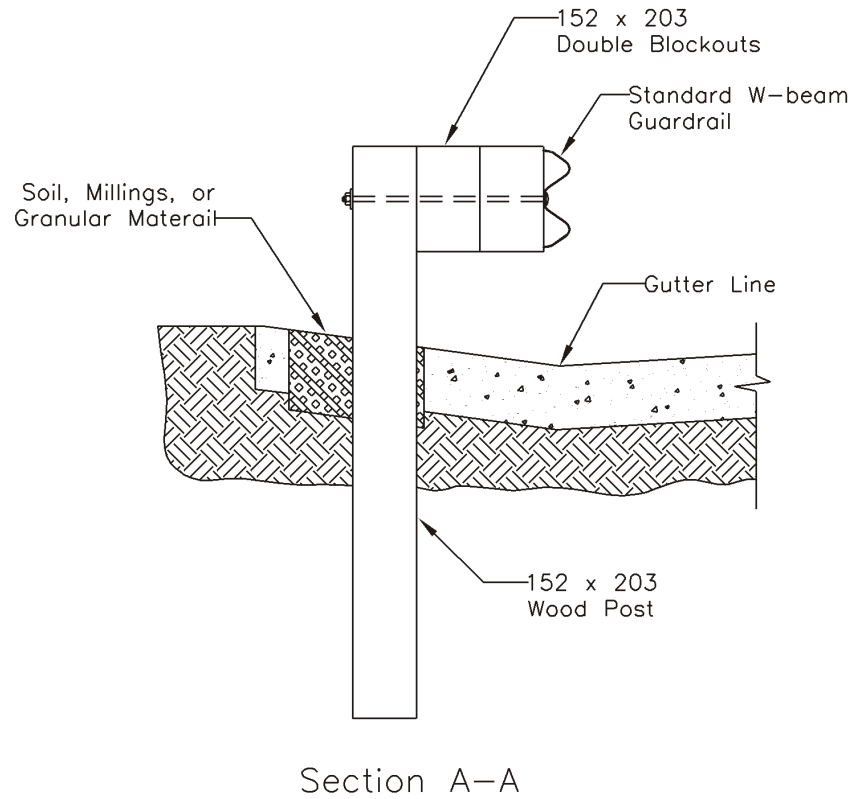

Figure 26. Barrier Separation Provided - Unlimited Approach Length - Transitions, Guardrails, and Terminals

Notes:

- 1 Barrier separation provided – walkway/pathway behind barrier.
- 2 Adequate approach length available for standard guardrail system.
- 3 FHWA approved TL-2, TL-3, or TL-4 approach guardrail transitions, guardrails, and guardrail end terminals.
- ④ Bridge rail or combination of bridge rail, approach guardrail transition, and strong-post guardrail may be used to protect the hazard behind the bridge rail. However, consideration must be given to the test-level rating of the roadside hardware associated with the required length-of-need.
- ⑤ Curb is located behind the guardrail end terminal.
- ⑥ Refer to Figure 28 for cross-sectional views A-A and B-B.

74

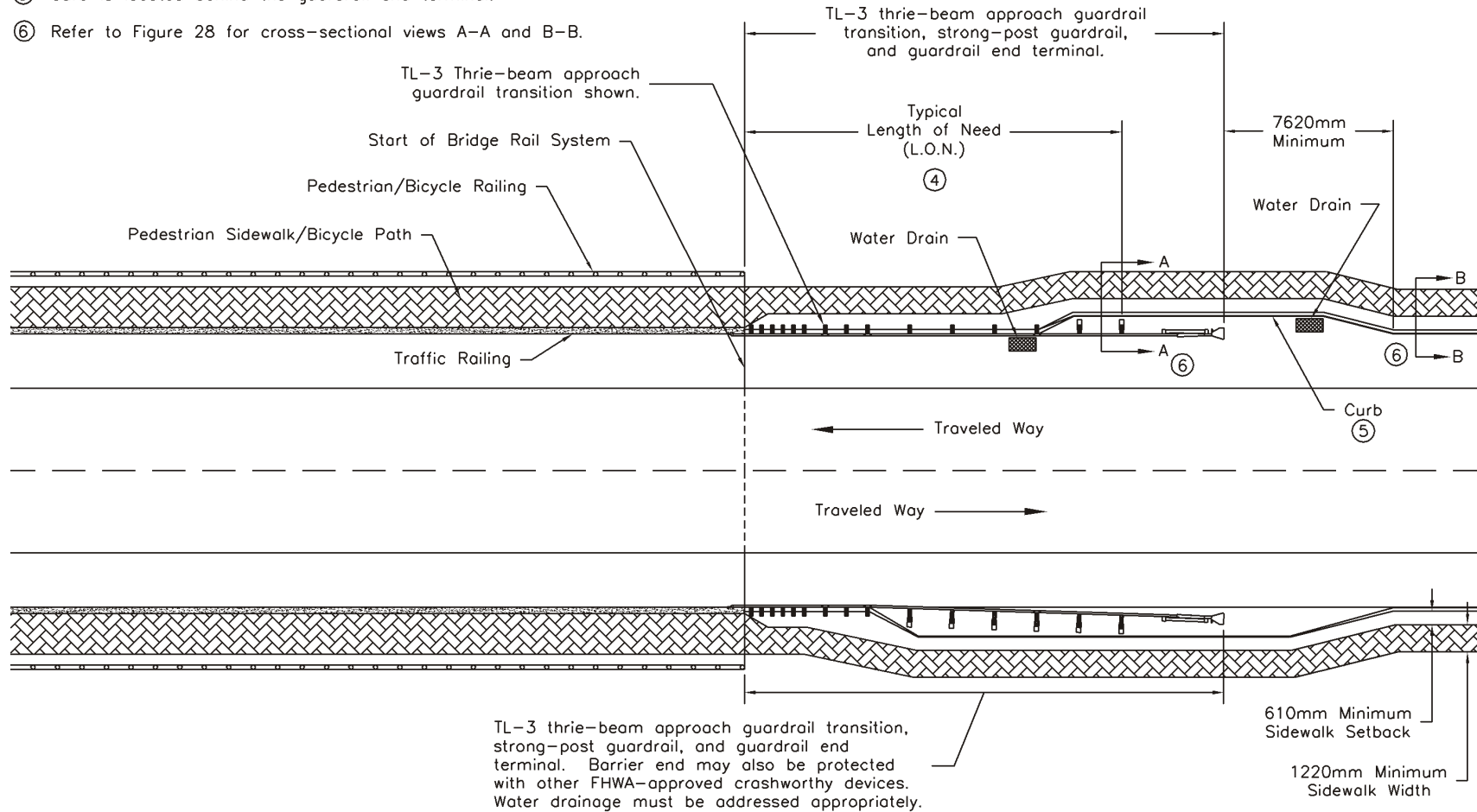

Figure 27. Barrier Separation Provided - Unlimited Approach Length - Transitions, Guardrails, and Terminals

Notes:

- 1 All dimensions in mm.
- 2 Upstream curb shown in Section B-B.
- 3 Curb and gutter line are shifted behind guardrail as shown in Section A-A.
- 4 Curb setback distance located behind the back face of posts should consider hydraulic efficiency requirements.

75

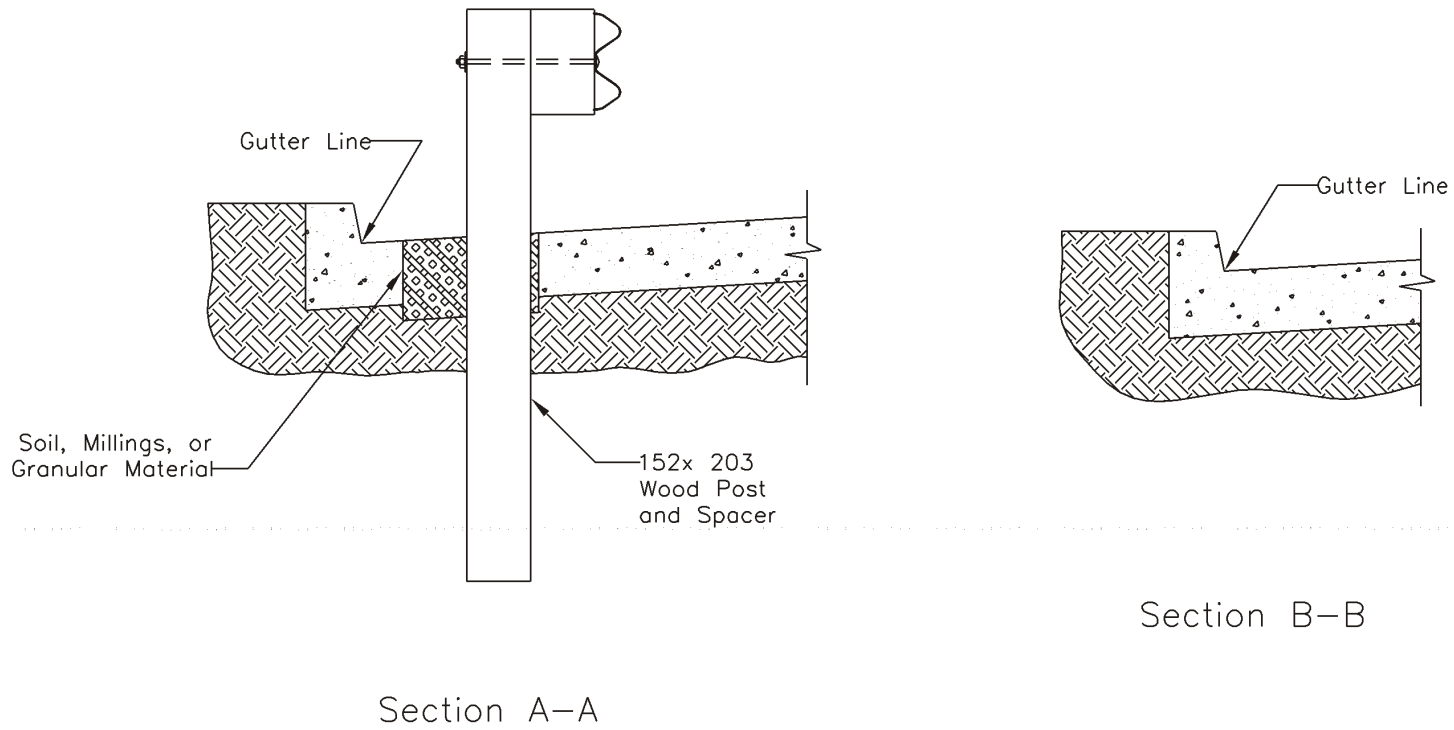

Figure 28. Barrier Separation Provided - Unlimited Approach Length - Transitions, Guardrails, and Terminals

to impede hydraulic flow, the curb and gutter line should be moved sufficiently behind the guardrail. The combination of the sloped roadway and shifted gutter line creates a low-lying pocket which allows water runoff to accumulate in this area. Therefore, a second water drain must also be installed in a manner similar to that shown in Figure 27. Finally, the pedestrian and bicycle pathways may have to be moved farther away from the guardrail and guardrail end terminal systems in order to maintain adequate sidewalk width and continuity of the pedestrian facility.

5.3.1.2 Crash Cushions

A scenario with unlimited approach length and barrier separation provided is shown in Figure 29. In this case, the bridge rail ends are protected with either TL-2 or TL-3 energy-absorbing crash cushions. However, it should be noted that the manufacturer of a crash cushion device is responsible for providing guidance for its proper application and installation. As a general rule, crash cushions should only be used at sites which have adequate level terrain and those which are void of curbs or other physical features that may degrade the device's safety performance (2,6). As shown in Figure 30, the curb was transitioned to a swale at a location upstream from the crash cushion in order to (1) minimize the potential for vehicular instabilities prior to reaching the crash cushion, (2) prevent climbing or vaulting over the barrier system, and (3) eliminate any restrictions on drainage capacity. Finally, it may be necessary to move the pedestrian and bicycle pathways farther away from the crash cushion in order to maintain adequate sidewalk width and continuity of the pedestrian facility.

A second scenario that has unlimited approach length, provides barrier separation, and incorporates TL-2 and TL-3 energy absorbing crash cushions is shown in Figure 31. In this case, the curb, if present on the approach roadway, is positioned behind the crash cushion. This curb

Notes:

- 1 Barrier separation provided – walkway/pathway behind barrier.
- 2 Adequate approach length available for standard guardrail system.
- 3 FHWA approved TL-2 or TL-3 crash cushions.
- ④ Bridge rail or combination of bridge rail and crash cushion may be used to protect the hazard behind the bridge rail. However, consideration must be given to the test-level rating of the roadside hardware associated with the required length-of-need.
- ⑤ Curb transitions to swale as shown.
- ⑥ Refer to Figure 30 for cross-sectional views A-A and B-B.

77

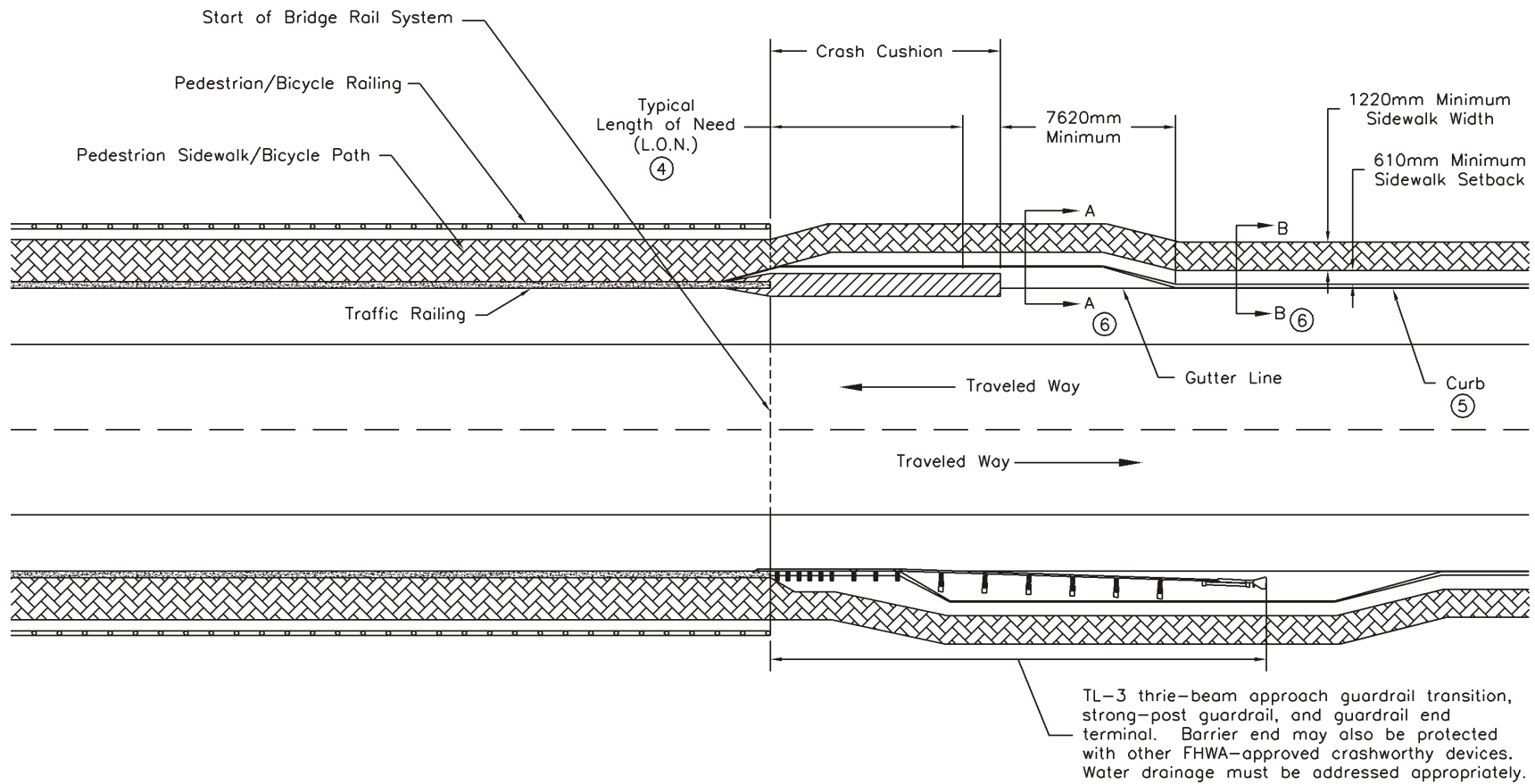
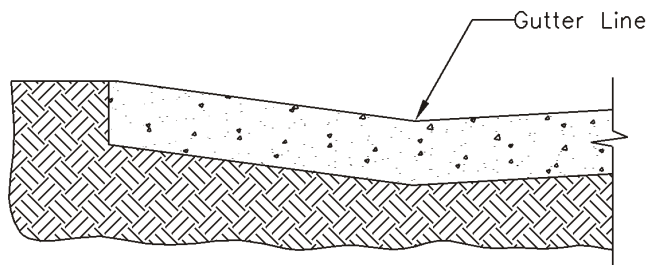

Figure 29. Barrier Separation Provided - Unlimited Approach Length - Crash Cushions

Notes:

- 1 All dimensions in mm.
- 2 Upstream curb shown in Section B-B.
- 3 Curb transitions to swale with maximum slope of 10:1, as shown in Section A-A.

78



Section A-A

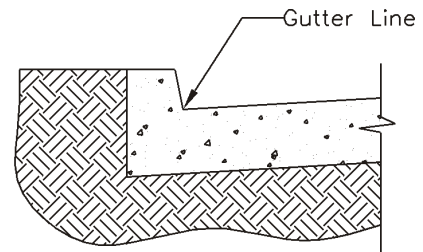

Section B-B

Figure 30. Barrier Separation Provided - Unlimited Approach Length - Crash Cushions

Notes:

- 1 Barrier separation provided – walkway/pathway behind barrier.
- 2 Adequate approach length available for standard guardrail system.
- 3 FHWA approved TL-2 or TL-3 crash cushions.
- ④ Bridge rail or combination of bridge rail and crash cushion may be used to protect the hazard behind the bridge rail. However, consideration must be given to the test-level rating of the roadside hardware associated with the required length-of-need.
- ⑤ Curb is positioned behind the crash cushion.

79

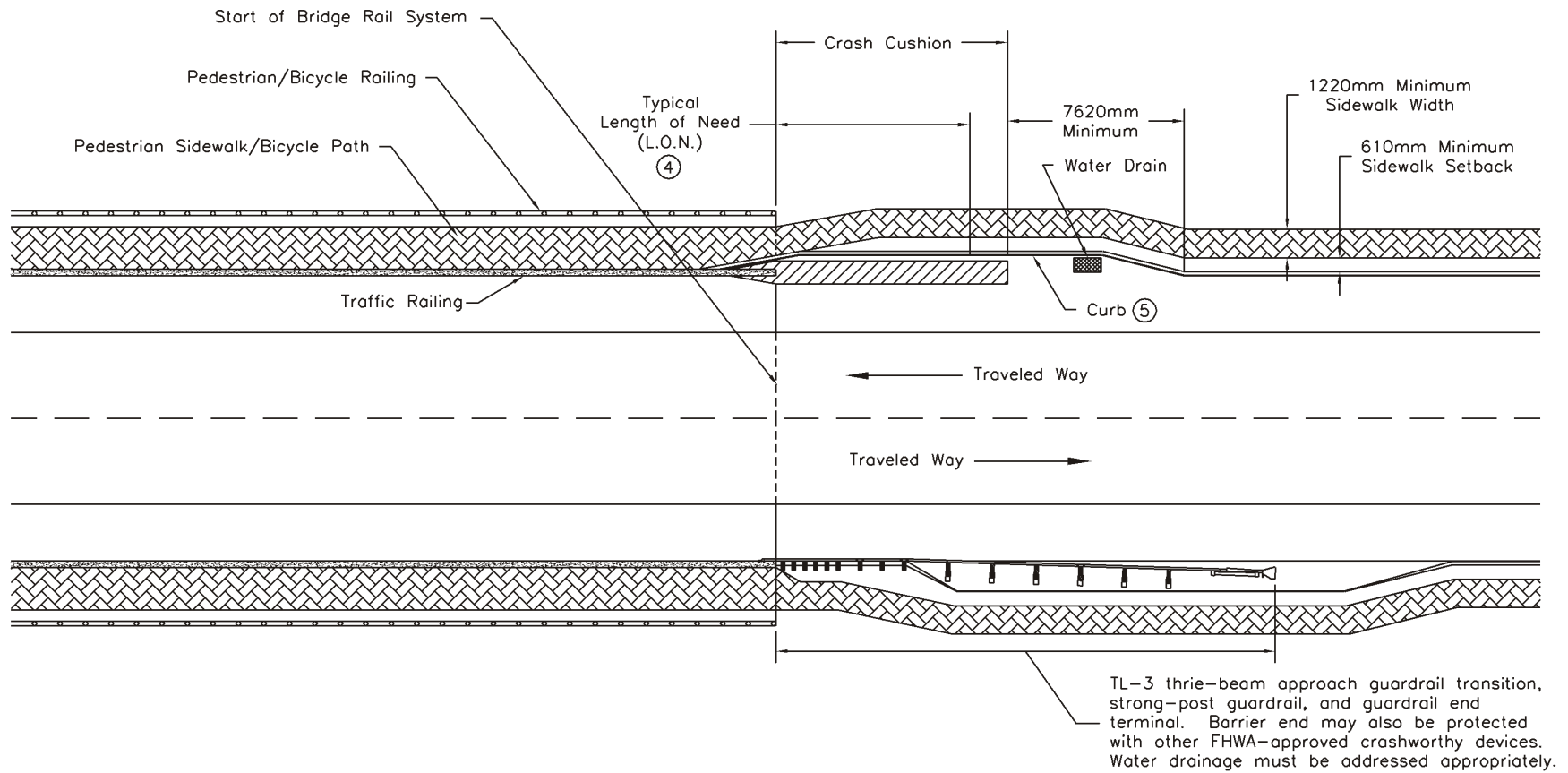

Figure 31. Barrier Separation Provided - Unlimited Approach Length - Crash Cushions

configuration also shifts the gutter line behind the crash cushion. The combination of the sloped roadway and shifted gutter line creates a low-lying pocket which allows water runoff to accumulate in this area. Therefore, a water drain must be installed in a manner similar to that shown in Figure 31. It also may be necessary to move the walkway/pathway away from the crash cushion in order to maintain adequate sidewalk width and continuity of the pedestrian facility.

5.3.1.3 Low-Height Barriers

A scenario that has unlimited approach length and provides barrier separation is shown in Figure 32. For this situation, a low-height barrier is provided and configured with a sloped end treatment, both of which are approved for TL-2 applications (23). Since pedestrians or bicyclists are positioned behind this barrier system, an independent pedestrian or bicycle railing will be required between the vehicle and pedestrian lanes. However, to date, there does not exist a pedestrian/bicycle railing that is approved for use on or directly behind this low-height bridge railing.

Independent pedestrian/bicycle railings are typically designed for only pedestrian/bicycle loading. As a result, potential safety concerns exist when these railings are subjected to vehicular impacts. For example, an impacting vehicle may dislodge structural elements from the pedestrian/bicycle railing and cause hazardous debris to be thrown into the pedestrian or bicycle lanes. In addition, bridge railing components could become fractured and potentially penetrate the vehicle's interior occupant compartment. For both of these scenarios, the pedestrians as well as the vehicles' occupants would be subjected to undue risk. Therefore, if this low-height bridge railing configuration is to be utilized for this application, special consideration must be directed to both the location and the design of the pedestrian/bicycle railing.

Notes:

- 1 Barrier separation provided – walkway/pathway behind barrier.
- 2 Adequate approach length available for standard guardrail system.
- 3 FHWA approved TL-2 low-height barrier.
- ④ The bridge rail end must be used to protect the hazard behind the bridge rail. The sloped end treatment has no redirective capabilities, and therefore, the bridge rail must extend through the required length-of-need.
- ⑤ Sloped end treatment smoothly transitions to the curb line. The sloped end treatment may be used without a curb if other methods are used to provide hydraulic drainage.
- ⑥ For oblique impacts, the pedestrian/bicycle railing must be placed behind zone of intrusion. Barriers 686 mm high or taller have a ZOI of 305 mm. Barrier shorter than 686 mm have a ZOI of 711 mm.
- ⑦ For end-on impacts, the pedestrian/bicycle railing must provide an acceptable safety performance in accordance with NCHRP Report No. 350 (1). It is noted that further research is required for the development of a pedestrian/bicycle railing for use with the low-height barrier.

181

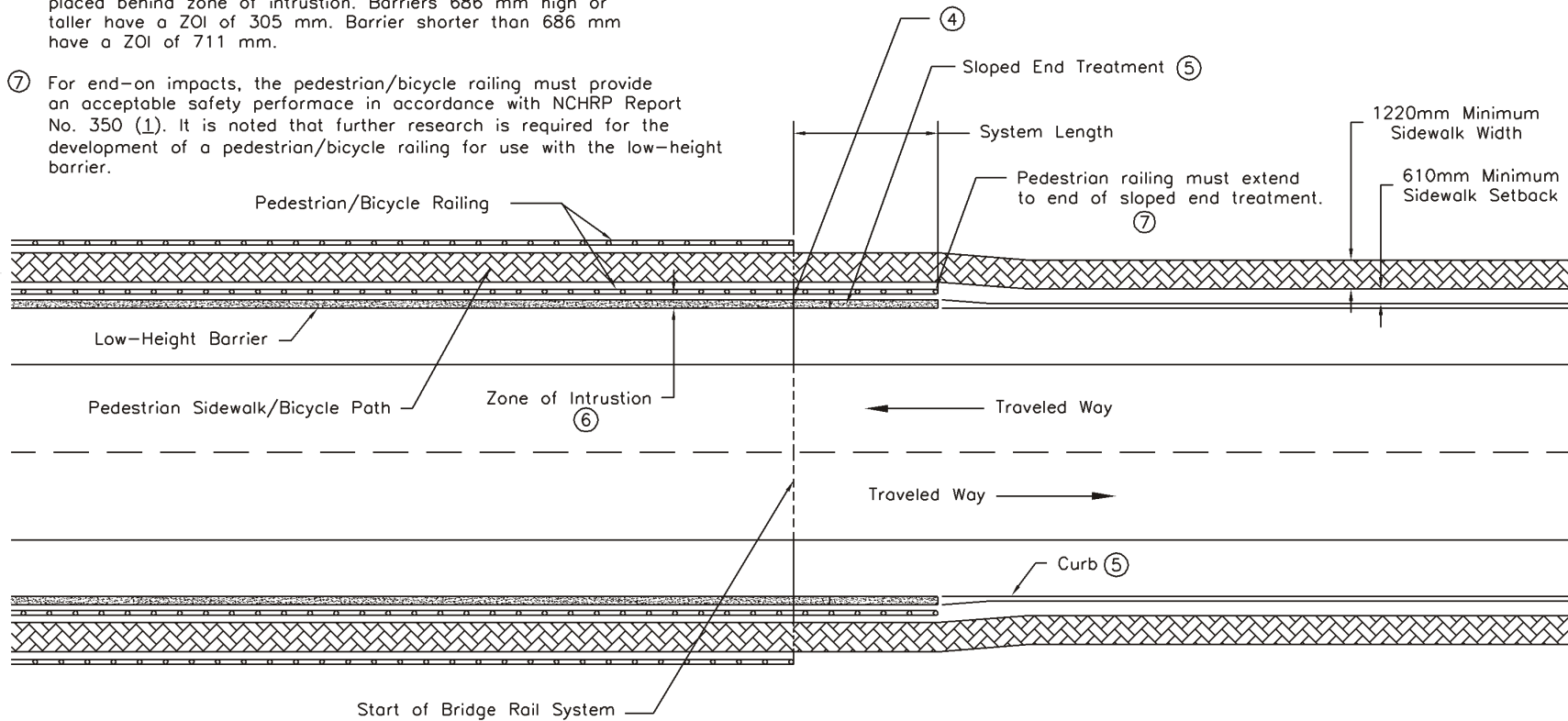

Figure 32. Barrier Separation Provided - Unlimited Approach Length - Low Height Barriers

Two alternatives are available to the engineers when considering the design of pedestrian/bicycle railings for oblique vehicular impacts. First, if the pedestrian/bicycle railing is physically attached to the low-height bridge railing, then full-scale vehicle crash testing in accordance with the NCHRP Report No. 350 impact safety standards would be required. Second, if the pedestrian/bicycle railing is not attached to the low-height bridge railing, then it is recommended that the pedestrian/bicycle railing be placed behind the traffic-side face of the barrier and outside of the zone of intrusion (ZOI). This position should be selected in order to ensure that it will not be struck by an impacting vehicle which may extend over the top of the bridge railing. For this second alternative, additional full-scale vehicle crash testing will not likely be required.

The ZOI for the TL-2 low-height concrete barrier is 711 mm, which is specified for all concrete barriers shorter than 686-mm tall in the MwRSF Report entitled *Guidelines for Attachments to Bridge Rails and Median Barriers* (32). If the railing is to contain pedestrians on foot, it must be a minimum of 1,067-mm tall. For bicycle facilities, the railing must be a minimum of 1,372-mm tall (2-3.7). The main benefits of the low-height barrier in this situation are its redirective capabilities at the TL-2 service level and the shortened height which greatly improves visibility for motorists. The disadvantage of this configuration is that an independent pedestrian/bicycle railing is required between the low-height barrier and the pedestrian/bicycle pathway, likely resulting in additional cost and complexity to the bridge structure.

Finally, the end treatment for the combination low-height and pedestrian/bicycle bridge railing will likely require a much more complex solution. If the combination railing's end terminal is installed tangent to the roadway and close to the back side of the low-height barrier, as shown in Figure 32, then a crashworthy end treatment will be required for both the low-height barrier as well

as the pedestrian/bicycle railing. However, if an independent pedestrian/bicycle railing is constructed sufficiently behind the low-height barrier, then the potential exists for only requiring that the sloped concrete end terminal be crashworthy.

5.3.1.4 Evaluation - Barrier Separation Provided, Unlimited Approach Length

Five methods for providing pedestrian protection on bridges where unlimited approach length exists at the end of the bridge and barrier separation is provided have been illustrated in Figures 25 through 32. If the bridge rail end is to be protected by transitions, guardrails, and guardrail end terminals, the first configuration shown in Figures 25 and 26 is the most suitable in terms of crashworthiness, pedestrian safety, and hydraulic efficiency. A swale, used in lieu of a standard curb, minimizes the potential for vehicular instabilities while providing adequate hydraulic drainage capacity. A second application using transitions, guardrails, and guardrail end terminals is shown in Figures 27 and 28. However, it should be noted that this case will likely be more costly than the first application due to the additional considerations deemed necessary in order to maintain adequate drainage. Crash cushions are the second option to be considered for the termination of bridge rail ends, as well as for the protection of pedestrians and bicyclists. Once again, as shown in Figures 29 and 30, a swale is placed underneath a crash cushion in order to minimize the potential for vehicular instabilities while providing adequate hydraulic drainage capacity. The crash cushion configurations depicted in Figures 29 and 31 are equivalent in terms of their crashworthiness. However, the curb alternative may not be preferred over the swale alternative due to the perceived higher construction costs and additional water inlet requirements. Finally, the low-height barrier with a pedestrian/bicycle railing, as illustrated in Figure 32, can be used to provide adequate pedestrian protection over bridges. However, there currently is not an NCHRP Report No. 350-

approved pedestrian/bicycle railing developed for use with the low-height barrier.

5.3.2 Limited Approach Length

Bridge sites with limited approach length will not allow the use of conventional approach guardrail transitions, standard guardrail, and guardrail end terminals. In these situations, the designer is forced to specify alternative bridge rail end treatments that are appropriate to satisfy the safety requirements of the site.

5.3.2.1 Crash Cushions

A scenario that provides barrier separation and has limited approach length is shown in Figure 33. In this case, the bridge rail ends are protected with either a TL-2 or TL-3 energy-absorbing crash cushion. A crash cushion is used in place of approach guardrail transitions, standard guardrails, and guardrail end terminals due to the close proximity of the intersecting roadway, street, or driveway on the approach side of the bridge. If a curb is required for drainage control, it should be positioned behind the crash cushion in order to maintain the crashworthiness of the device. Finally, it also may be necessary to move the pedestrian and bicycle pathways farther away from the crash cushion in order to maintain adequate sidewalk width and continuity of the pedestrian facility.

5.3.2.2 Low-Height Barriers

A scenario that provides barrier separation and has limited approach length is shown in Figure 34. For this situation, a low-height barrier is once again provided and configured with a sloped end treatment, both of which are approved for TL-2 applications (23). For this example, a curb is provided for drainage control at the edge of the roadway and smoothly transitions to the shape of the upstream end of the sloped concrete end terminal.

One of the situations for which the low-height bridge rail was developed was for the

accommodation of pedestrians or bicyclists when site restrictions prevent the use of conventional bridge rails, approach guardrail transitions, and guardrail end terminals. Since pedestrians or bicyclists are positioned behind this barrier system, an independent pedestrian or bicycle railing will be required between the vehicle and pedestrian lanes. However, to date, there does not exist a pedestrian/bicycle railing that is approved for use on or directly behind this low-height bridge railing. Additional discussion on the design, location, and crashworthiness of the pedestrian and bicycle railing system is the same as that provided previously in Section 5.3.1.3.

The ZOI for the TL-2 low-height concrete barrier is 711 mm, which is specified for all concrete barriers shorter than 686-mm tall in the MwRSF Report entitled *Guidelines for Attachments to Bridge Rails and Median Barriers* (32). If the railing is to contain pedestrians on foot, it must be a minimum of 1,067-mm tall. For bicycle facilities, the railing must be a minimum of 1,372-mm tall (2-3,7). The main benefit of the low-height barrier in this situation is minimal length required to terminate the barrier. The low-height barrier also provides redirective capabilities at the TL-2 service level, and the shortened height greatly improves driver visibility. The disadvantage of this configuration is that an independent pedestrian/bicycle railing is required between the low-height barrier and the pedestrian and bicycle pathways, likely resulting in additional cost and complexity to the bridge structure.

5.3.2.3 Short Radius Guardrails

A third scenario that provides barrier separation and has limited approach length Figure 35. In this case, the bridge rail ends are protected by a short radius guardrail system. A short radius guardrail system is provided for situations where typical bridge rail end treatments cannot be used due to the close proximity of an intersecting roadway, street, or driveway. The guardrail section of

Notes:

- 1 Barrier separation provided – walkway/pathway behind barrier.
- 2 Approach length is limited.
- 3 FHWA approved TL-2 or TL-3 crash cushions.
- ④ Bridge rail or combination of bridge rail and crash cushion may be used to protect the hazard behind the bridge rail. However, consideration must be given to the test-level rating of the roadside hardware associated with the required length-of-need.
- ⑤ Curb is positioned behind the crash cushion.

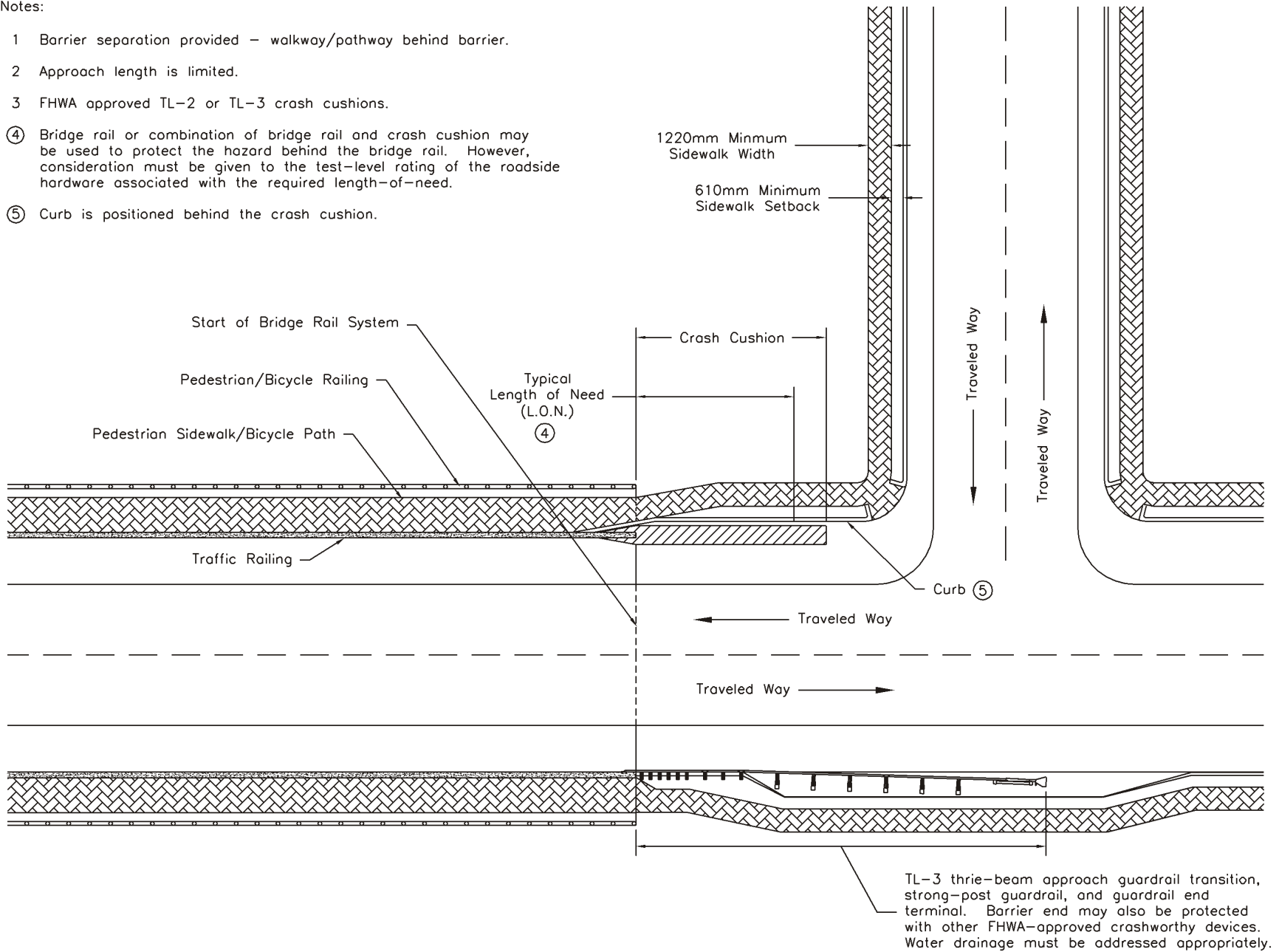

Figure 33. Barrier Separation Provided - Limited Approach Length - Crash Cushions

Notes:

- 1 Barrier separation provided – walkway/pathway on front side of bridge rail.
- 2 Approach length is limited.
- 3 Short Radius Guardrails – system is currently under development.
- ④ Bridge rail or combination of bridge rail and short radius barrier may be used to protect the hazard behind the bridge rail. However, consideration must be given to the test-level rating of the roadside hardware associated with the required length-of-need.
- ⑤ Curb is behind approach guardrail transition, guardrail, and guardrail end terminal.
- ⑥ Refer to Figure 36 for cross-sectional views A-A and B-B.

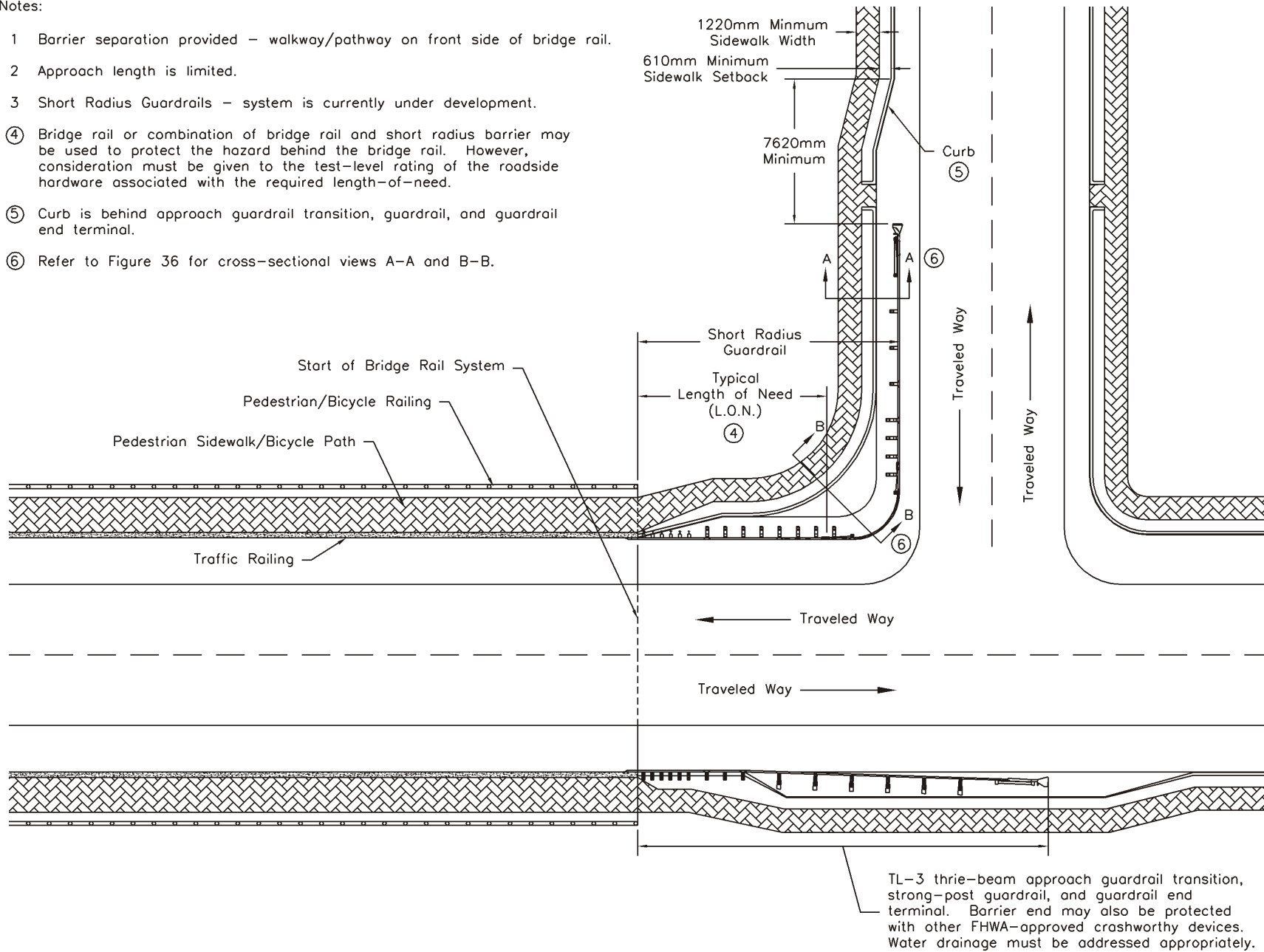

Figure 35. Barrier Separation Provided - Limited Approach Length - Short Radius Guardrails

the barrier curves around the corner and maintains a position between the pedestrian walkway and the traffic lanes. At this location, the guardrail is terminated by a standard guardrail end terminal. A pedestrian crossing is then provided at the end of the guardrail terminal.

If a curb is utilized, it must be moved laterally away from the vehicle lanes and placed behind the guardrail system. As shown in Figure 36, the standard curb is transitioned to a section having a flattened face sloping upward and away from the gutter line and at a location directly behind the elbow of the short radius system. If a vehicle impacts the nose section of the short radius guardrail system, the vehicle's front end should be adequately captured prior to the vehicle's front wheels traversing over the curb. Subsequently, the vehicle will continue to penetrate into the barrier system and then will be brought to a controlled stop. This behavior will be best achieved with the use of a flattened slope measuring no greater than 10:1.

Finally, it should be noted that this short radius guardrail system is currently under development and has not met the NCHRP Report No. 350 safety standards. However, it has been included herein since it may in the future provide a viable alternative for meeting either the TL-2 or TL-3 impact safety standards.

5.3.2.4 Evaluation - Barrier Separation Provided, Limited Approach Length

Three methods for providing pedestrian protection on bridges where there exists limited approach length due to an intersecting street, and barrier separation is provided have been illustrated in Figures 33 through 36. Of these three configurations, an NCHRP Report No. 350-approved crash cushion is the most viable means for terminating the bridge rail ends and for protecting pedestrians and bicyclists, as illustrated in Figure 33. Currently, a short radius guardrail system has not met the NCHRP Report No. 350 impact safety standards. However, a short radius

guardrail system crash tested according to the NCHRP Report No. 230 criteria may be an acceptable alternative for use in TL-2 applications. Finally, the low-height barrier with a pedestrian/bicycle railing, as illustrated in Figure 35, can be used to provide adequate pedestrian protection over bridges. However, currently there is not an NCHRP Report No. 350-approved pedestrian/bicycle railing developed for use with the low-height barrier.

Notes:

- 1 All dimensions in mm.
- 2 Curb placement relative to guardrail shown in Section A-A.
- 3 Swale detail shown in Section B-B.
- 4 Curb setback distance located behind the back face of posts should consider hydraulic efficiency requirements.

16

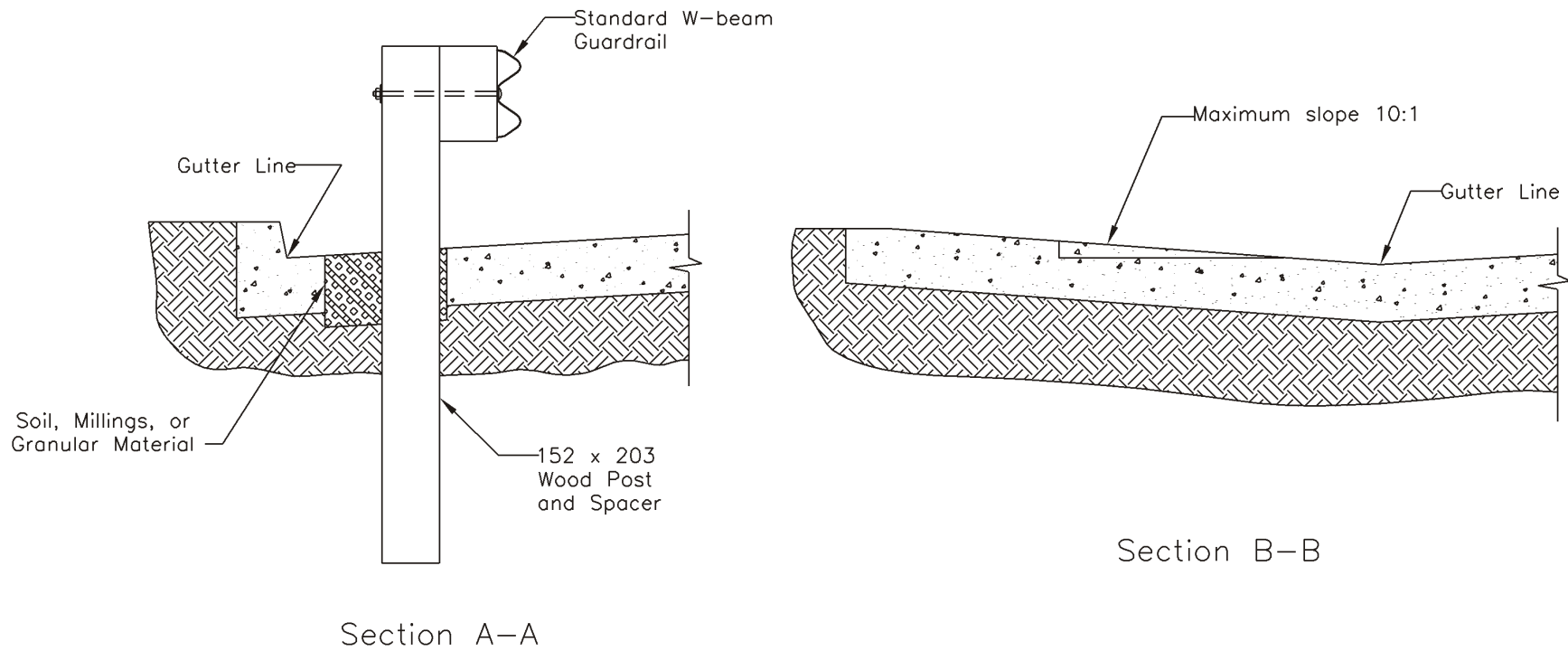

Figure 36. Barrier Separation Provided - Limited Approach Length - Short Radius Guardrails

6 SUMMARY AND CONCLUSIONS

The objectives of this study were to identify the most common scenarios in which the protection of pedestrians on bridges is desirable and then develop bridge rail and bridge rail end treatment configurations to accommodate those situations. The first study objective was achieved by performing a field investigation, a survey of state transportation agencies, and an extensive literature review. The field investigation and state survey resulted in the identification of the most common situations where pedestrian protection is desired. The literature review identified roadside hardware available, or currently under development, for use in providing improved pedestrian protection on or near the ends of bridges. Recommendations for the placement and design of standard barrier configurations have been provided in the form of generalized site drawings. The barrier configurations were developed and organized using two main criteria: (1) the presence or absence of a physical barrier separating the vehicle and pedestrian lanes and (2) the amount of available approach length upstream from the bridge rail ends.

It was impractical and unnecessary to conduct full-scale vehicle crash tests for all of the recommended barrier configurations. Instead, the barrier configurations outlined within this report were based on NCHRP Report No. 350-approved hardware, roadside hardware meeting prior safety standards, hardware believed to provide moderate safety, hardware currently under development, and sound engineering judgement. Therefore, it is noted that the barrier configurations recommended herein are not equivalent in terms of the level of pedestrian safety provided. As a result, sound engineering judgement is required when determining which barrier configuration to implement.

Although this report outlines some suitable barrier configurations for use in the protection

of pedestrians on bridges, the information upon which the recommendations were developed is by no means complete. The barrier configurations illustrated herein were developed based upon the limited data and general guidelines that are currently available. Therefore, it should be recognized that the final product is limited to a similar degree. In that regard, it is concluded that additional research studies and crash testing programs that yield objective results would greatly enhance the present state of knowledge from which these engineering judgements were based. Obtaining more objective data would undoubtedly expand the scope of the solutions presented herein, and ultimately improve the safety of pedestrian facilities on and near the ends of bridges.

7 RECOMMENDATIONS

In a future study, an objective methodology should be established for roadway and bridge engineers to utilize when assessing the need for pedestrian protection as well as to assist in adequately and consistently specifying pedestrian safety facilities on and near the ends of bridges and under various traffic conditions. Development of such an objective methodology will likely be achieved by using the RSAP benefit-to-cost ratio analysis program, resulting in general guidelines that can be applied to most roadside situations. The barrier configurations developed within this report should be evaluated using this objective methodology in order to rank and determine which alternatives provide the greatest pedestrian safety for a given site. The existence of objective assessment and specification techniques for use by engineers and designers will lead to safer pedestrian facilities on or near the ends of bridges.

Curbs, used in conjunction with roadside barriers, is another area where further research is required in order to improve the safety of pedestrian facilities on or near bridges. Currently, engineers and designers have very limited guidance when the placement of roadside barriers behind or above curbs is required. Research studies involving computer simulation modeling and full-scale vehicle crash testing should continue in order to investigate vehicle behaviors during impacts with curb/barrier combinations. The results will provide knowledge and insight with which objective guidelines can later be developed.

There is a need for new TL-2 and TL-3 bridge railing end treatments that can accommodate bridge sites with limited approach length beyond the bridge end. The short radius guardrail system is a natural solution to this problem. However, a short radius guardrail system has not met the TL-2 or TL-3 safety standards found in NCHRP Report No. 350. Therefore, it is apparent that the

development and approval of a short radius guardrail system for use in these situations would greatly benefit the safe accommodation of pedestrians on and near the ends of bridges.

Finally, increased pedestrian safety on or near bridges could be provided with the continued development of crashworthy vehicle/pedestrian and vehicle/bicycle railings. As discussed in Section 2.6.3, only a few NCHRP Report No. 350-approved vehicle/pedestrian and vehicle/bicycle railings are available for use where no barrier separation is provided, and even fewer crashworthy systems are available for situations where barrier separation is provided. With physical barrier separation being the most common and most effective method to separate vehicles and pedestrians, it is apparent that the specification of more crashworthy combination bridge railings would enhance the safety of pedestrians on bridges.

8 REFERENCES

1. Ross, H.E., Sicking, D.L., Zimmer, R.A. and Michie, J.D., *Recommended Procedures for the Safety Performance Evaluation of Highway Features*, National Cooperative Highway Research Program (NCHRP) Report No. 350, Transportation Research Board, Washington, D.C., 1993.
2. *A Policy on Geometric Design of Highways and Streets*, American Association of State Highway and Transportation Officials (AASHTO), Washington, D.C., 2001.
3. *AASHTO LRFD Bridge Design Specifications*, Customary U.S. Units – First Edition, American Association of State Highway and Transportation Officials (AASHTO), 2001 Interim.
4. *Guide for the Development of Bicycle Facilities*, American Association of State Highway and Transportation Officials (AASHTO), Washington, D.C., 1999.
5. Wilkinson, W.C., III, Clarke, A., Epperson, B., Knoblauch, R., *Selecting Roadway Design Treatments to Accommodate Bicycles*, Report No. FHWA-RD-92-073, Submitted to the Office of Safety and Traffic Operations, Federal Highway Administration, Performed by Center for Applied Research, Inc., January 1994.
6. *Roadside Design Guide*, American Association of State Highway and Transportation Officials (AASHTO), Washington, D.C., 2002.
7. *Standard Specifications for Highway Bridges*, 15th Edition, American Association of State Highway and Transportation Officials (AASHTO), Washington, D.C., 1992.
8. Olson, R.M., Weaver, G.D., Ross, H.E. Jr., and Post, E.R., *Effect of Curb Geometry and Location on Vehicle Behavior*, NCHRP Report 150, 1974.
9. Ray, M.H., Plaxico, C.A., *Recommended Guidelines for Curbs and Curb-Barrier Combinations*, NCHRP Interim Report 22-17, October, 2000.
10. Faller, R.K., Reid, J.D., Rohde, J.R., Sicking, D.L., Keller, E.A., *Two Approach Guardrail Transitions for Concrete Safety Shape Barriers*, Final Report to the Midwest State's Regional Pooled Fund Program, Transportation Record No. TRP-03-69-98, Midwest Roadside Safety Facility, University of Nebraska-Lincoln, May 15, 1998.
11. Faller, R.K., Reid, J.D., Rohde, J.R., *Two Approach Guardrail Transitions for Concrete Safety Shape Barriers*, Transportation Record No. 1647, Transportation Research Board, National Research Council, 1998, pp 111-121.

12. Buth, C.E., Menges, W.L., Schoeneman, S.K., *Roadside Safety Hardware Tested in Accordance With NCHRP Report 350*, Report No. 404201-F, Texas Transportation Institute, Texas A&M University, College Station, Texas, February 2001, pp 5-22.
13. Polivka, K.A., Faller, R.K., Sicking, D.L., Rohde, J.R., Reid, J.D., and Holloway, J.C., *Guardrail and Guardrail Terminals Installed Over Curbs*, Final Report to the Midwest State's Regional Pooled Fund Program, Transportation Record No. TRP-03-83-99, Midwest Roadside Safety Facility, University of Nebraska-Lincoln, March 21, 2000.
14. Polivka, K.A., Faller, R.K., Sicking, D.L., Rohde, J.R., Reid, J.D., and Holloway, J.C., *Guardrail and Guardrail Terminals Installed Over Curbs – Phase II*, Final Report to the Midwest State's Regional Pooled Fund Program, Transportation Record No. TRP-03-105-00, Midwest Roadside Safety Facility, University of Nebraska-Lincoln, November 5, 2001.
15. Polivka, K.A., Faller, R.K., Sicking, D.L., Rohde, J.R., Reid, J.D., and Holloway, J.C., *Design & Evaluation of the TL-4 Minnesota Combination Traffic/Bicycle Bridge Rail*, Final Report to the Midwest State's Regional Pooled Fund Program, Transportation Record No. TRP-03-109-01, Midwest Roadside Safety Facility, University of Nebraska-Lincoln, September 5, 2001.
16. Bullard, D.L., Jr., Menges, W.L., Buth, C.E., *Development of Combination Pedestrian-Traffic Bridge Railings*, Transportation Research Record No. 1468, Transportation Research Board, National Research Council, 1994, pp 41-53.
17. *Guide Specifications for Bridge Railings*, American Association of State Highway and Transportation Officials (AASHTO), Washington, D.C., 1989.
18. Hirsch, T.J., Buth, C.E., *Aesthetically Pleasing Combination Pedestrian-Traffic Bridge Rail*, Transportation Research Record No. 1367, Transportation Research Board, National Research Council, 1992, pp 23-35.
19. Kimball, C.E., Mayer, J.B., *Full-Scale Crash Evaluation of the NETC 4-Bar Sidewalk-Mounted Steel Bridge Railing*, Report No. FHWA-RD-99-027, Submitted to the Office of Contracts and Procurement, Federal Highway Administration, Performed by Southwest Research Institute, 1998.
20. Guidry, T.R., Beason, W.L., *Development of a Low-Profile Portable Concrete Barrier*, Transportation Research Record No. 1367, Transportation Research Board, National Research Council, 1992, pp 36-46.
21. Guidry, T.R., Beason, W.L., *Development of a Low-Profile Portable Concrete Barrier*, Research Report No. 990-4F, Texas Transportation Institute, Texas A&M University, College Station, Texas, November 1991.

22. Beason, W.L., Menges, W.L., and Ivey, D.L., *Compliance Testing of an End Treatment for the Low-Profile Concrete Barrier*, Research Report No. 1403-S, Texas Transportation Institute, Texas A&M University, College Station, Texas, April 1998.
23. Polivka, K.A., Faller, R.K., Sicking, D.L., Rohde, J.R., Reid, J.D., and Holloway, J.C., *Development of a Low Profile Bridge Rail for Test Level 2 Applications*, Final Report to the Midwest State's Regional Pooled Fund Program, Transportation Record No. TRP-03-109-02, Midwest Roadside Safety Facility, University of Nebraska-Lincoln, August 20, 2002.
24. Consolazia, G.R., Chung, J.H., Gurley, K.R., *Development of a Low Profile Work Zone Barrier Using Impact Finite Element Simulation*, Presented at the 2002 Annual Meeting of the Transportation Research Board, Washington, D.C., January 2002.
25. Kansas Department of Transportation, Design Manual, Volume III, Version 9/01, Bridge Section, Metric.
26. Missouri Department of Transportation, Project Development Manual, Chapter IV, Revised 4/1/02, Available: <<http://www.modot.state.mo.us/design/ppdm/ppdm.htm>> [2002, June 4].
27. Minnesota Department of Transportation, Bridge Design Manual, July 1998.
28. South Dakota Department of Transportation, Road Design Manual, Available: <http://www.sddot.com/pe/roaddesign/plans_rdmanual.asp> [2002, June 4].
29. Texas Department of Transportation, Bridge Railing Manual, Revised February 2002, Available: <http://manuals.dot.state.tx.us/dynaweb/colbridg/rlg/@Generic__BookView> [2002, June 4].
30. Texas Department of Transportation, Roadway Design Manual, Revised April 2002, Available: <http://manuals.dot.state.tx.us/dynaweb/coldesig/rdw/@Generic__BookView> [2002, June 4].
31. Michie, J.D., *Recommended Procedures for the Safety Performance Evaluation of Highway Appurtenances*, National Cooperative Highway Research Program (NCHRP) Report No. 230, Transportation Research Board, Washington, D.C., March 1981.
32. Keller, E.A., Sicking, D.L., Faller, R.K., Polivka, K.A., Rohde, J.R., *Guidelines for Attachments to Bridge Rails and Median Barriers*, Draft Report to the Midwest State's Regional Pooled Fund Program, Transportation Record No. TRP-03-98-01, Midwest Roadside Safety Facility, University of Nebraska-Lincoln, April 13, 2001.