

University of Nebraska - Lincoln

DigitalCommons@University of Nebraska - Lincoln

---

Final Reports & Technical Briefs from Mid-  
America Transportation Center

Mid-America Transportation Center

---

2009

## DYNAMIC EVALUATION OF A PINNED ANCHORING SYSTEM FOR NEW YORK STATE'S TEMPORARY CONCRETE BARRIERS

Christopher N. Howard

Cale J. Stolle

Karla A. Lechtenberg

Ronald K. Faller

John D. Reid

*See next page for additional authors*

Follow this and additional works at: <https://digitalcommons.unl.edu/matcreports>



Part of the [Civil Engineering Commons](#), and the [Transportation Engineering Commons](#)

---

This Article is brought to you for free and open access by the Mid-America Transportation Center at DigitalCommons@University of Nebraska - Lincoln. It has been accepted for inclusion in Final Reports & Technical Briefs from Mid-America Transportation Center by an authorized administrator of DigitalCommons@University of Nebraska - Lincoln.

---

**Authors**

Christopher N. Howard, Cale J. Stolle, Karla A. Lechtenberg, Ronald K. Faller, John D. Reid, and Dean L. Sicking

---

FINAL REPORT

# DYNAMIC EVALUATION OF A PINNED ANCHORING SYSTEM FOR NEW YORK STATE'S TEMPORARY CONCRETE BARRIERS

Submitted by

**Christopher N. Howard, B.S.M.E., E.I.T.**

Former Graduate Research Assistant

**Karla A. Lechtenberg, M.S.M.E., E.I.T.**

Research Associate Engineer

**John D. Reid, Ph.D.**

Professor

**Cale J. Stolle**

Undergraduate Research Assistant

**Ronald K. Faller, Ph.D., P.E.**

Research Assistant Professor

**Dean L. Sicking, Ph.D., P.E.**

MwRSF Director and Professor

## MIDWEST ROADSIDE SAFETY FACILITY

University of Nebraska-Lincoln

527 Nebraska Hall

Lincoln, Nebraska 68588-0529

(402) 472-0965

Submitted to

## NEW YORK STATE DEPARTMENT OF TRANSPORTATION

50 Wolf Road

6<sup>th</sup> Floor

Albany, New York 12232

MwRSF Research Report No. TRP-03-216-09

September 8, 2009

## TECHNICAL REPORT DOCUMENTATION PAGE

1. Report No. <b>TRP-03-216-09</b>	2.	3. Recipient's Accession No.	
4. Title and Subtitle <b>Dynamic Evaluation of a Pinned Anchoring System for New York State's Temporary Concrete Barriers</b>		5. Report Date <b>September 8, 2009</b>	
7. Author(s) <b>Howard, C.H., Stolle, C.J., Lechtenberg, K.A., Faller, R.K., Reid, J.D., and Sicking, D.L.</b>		8. Performing Organization Report No. <b>TRP-03-216-09</b>	
9. Performing Organization Name and Address <b>Midwest Roadside Safety Facility (MwRSF) University of Nebraska-Lincoln 527 Nebraska Hall Lincoln, Nebraska 68588-0529</b>		10. Project/Task/Work Unit No.	
12. Sponsoring Organization Name and Address <b>New York State Department of Transportation 50 Wolf Road 6<sup>th</sup> Floor Albany, New York 12232</b>		11. Contract © or Grant (G) No.	
15. Supplementary Notes <b>Prepared in cooperation with U.S. Department of Transportation, Federal Highway Administration.</b>		13. Type of Report and Period Covered <b>Final Report: 2008 – 2009</b>	
16. Abstract (Limit: 200 words)		14. Sponsoring Agency Code <b>Project No. TPF-5(193), Supplement #8</b>	
17. Document Analysis/Descriptors <b>Highway Safety, Roadside Appurtenances, Longitudinal Barrier, Temporary Concrete Barrier, Anchored, Pinned, Crash Test, Compliance Test, MASH</b>		18. Availability Statement <b>No restrictions. Document available from: National Technical Information Services, Springfield, Virginia 22161</b>	
19. Security Class (this report) <b>Unclassified</b>	20. Security Class (this page) <b>Unclassified</b>	21. No. of Pages <b>92</b>	22. Price

## **DISCLAIMER STATEMENT**

This report was funded in part through a grant from the Federal Highway Administration, U.S. Department of Transportation. The contents of this report reflect the views of the authors who are responsible for the facts and accuracy of the data presented herein. The contents do not necessarily reflect the official views or policies of the New York State Department of Transportation, the United States Department of Transportation, nor the Federal Highway Administration. This report does not constitute a standard, specification, regulation, product endorsement, or an endorsement of manufacturers.

## **UNCERTAINTY OF MEASUREMENT STATEMENT**

The Midwest Roadside Safety Facility (MwRSF) has determined the uncertainty of measurements for several parameters involved in non-standard testing of roadside safety hardware as well as in standard full-scale crash testing of roadside safety features. Information regarding the uncertainty of measurements for critical parameters is available upon request by the sponsors and the Federal Highway Administration.

## **ACKNOWLEDGEMENTS**

The authors wish to acknowledge several sources that made a contribution to this project:

(1) the New York State Department of Transportation for sponsoring the project and (2) MwRSF personnel for constructing the barrier and conducting the crash test.

A special thank you is also given to the following individuals who made a contribution to the completion of this research project.

### **Midwest Roadside Safety Facility**

J.R. Rohde, Ph.D., P.E., Associate Professor  
J.C. Holloway, M.S.C.E., E.I.T., Test Site Manager  
R.W. Bielenberg, M.S.M.E., E.I.T., Research Associate Engineer  
C.L. Meyer, B.S.M.E., E.I.T., Research Associate Engineer  
S.K. Rosenbaugh, M.S.C.E., E.I.T., Research Associate Engineer  
K.L. Krenk, Maintenance Mechanic  
A.T. Russell, B.S.B.A., Shop Manager  
A.T. McMaster, Laboratory Mechanic  
Undergraduate and Graduate Research Assistants

### **New York State Department of Transportation**

Lyman L. Hale III, P.E., Senior Engineer  
Pratip Lahiri, P.E., Standards and Specifications Section  
Brad Bortnick, P.E., Design Services Bureau  
John Ferry, Construction

### **Federal Highway Administration**

Jim Growney, P.E., New York Division Office

**TABLE OF CONTENTS**

TECHNICAL REPORT DOCUMENTATION PAGE ..... i

DISCLAIMER STATEMENT ..... ii

UNCERTAINTY OF MEASUREMENT STATEMENT ..... ii

ACKNOWLEDGEMENTS ..... iii

TABLE OF CONTENTS ..... iv

LIST OF FIGURES ..... vi

LIST OF TABLES ..... viii

1 INTRODUCTION ..... 1

    1.1 Problem Statement ..... 1

    1.2 Research Objective ..... 3

    1.3 Scope ..... 3

2 LITERATURE REVIEW ..... 4

3 TEST REQUIREMENTS AND EVALUATION CRITERIA ..... 7

    3.1 Test Requirements ..... 7

    3.2 Evaluation Criteria ..... 8

4 TEST CONDITIONS ..... 10

    4.1 Test Facility ..... 10

    4.2 Vehicle Tow and Guidance System ..... 10

    4.3 Test Vehicle ..... 10

    4.4 Data Acquisition Systems ..... 15

        4.4.1 Accelerometers ..... 15

        4.4.2 Rate Transducers ..... 16

        4.4.3 Pressure Tape Switches ..... 16

        4.4.4 High Speed Photography ..... 17

5 DESIGN DETAILS ..... 19

6 FULL-SCALE CRASH TEST NO. NYTCB-4 ..... 33

    6.1 Test No. NYTCB-4 ..... 33

    6.2 Weather Conditions ..... 33

    6.3 Test Description ..... 33

    6.4 Barrier Damage ..... 35

    6.5 Vehicle Damage ..... 36

    6.6 Occupant Risk ..... 37

    6.7 Discussion ..... 38

7 SUMMARY, CONCLUSIONS, AND RECOMMENDATIONS..... 60

8 REFERENCES ..... 62

9 APPENDICES ..... 64

    APPENDIX A. Vehicle Center of Gravity Determination ..... 65

    APPENDIX B. Material Specifications ..... 67

    APPENDIX C. Vehicle Deformation Data..... 71

    APPENDIX D. Accelerometer and Rate Transducer Data Analysis..... 77



## LIST OF FIGURES

Figure 1. Test Vehicle, Test NYTCB-4.....	11
Figure 2. Vehicle Dimensions, Test NYTCB-4.....	12
Figure 3. Target Geometry, Test NYTCB-4.....	14
Figure 4. Camera Locations, Test NYTCB-4.....	18
Figure 5. Pinned Temporary Concrete Barrier System Layout, Test NYTCB-4.....	21
Figure 6. Temporary Concrete Barrier Details, Test NYTCB-4.....	22
Figure 7. Temporary Concrete Barrier Reinforcement Details, Test NYTCB-4.....	23
Figure 8. Connection Key Assembly Details, Test NYTCB-4.....	24
Figure 9. Connection Key Assembly Details, Test NYTCB-4.....	25
Figure 10. Temporary Concrete Barrier Connector Assembly Details, Test NYTCB-4.....	26
Figure 11. Temporary Concrete Barrier Connection Details, Test NYTCB-4.....	27
Figure 12. Bill of Bars, Test NYTCB-4.....	28
Figure 13. Bill of Materials, Test NYTCB-4.....	29
Figure 14. Pinned Temporary Concrete Barrier, Test NYTCB-4.....	30
Figure 15. Connection Key, Test NYTCB-4.....	31
Figure 16. Anchored Barrier Sections, Test NYTCB-4.....	32
Figure 17. Summary of Test Results and Sequential Photographs, Test NYTCB-4.....	39
Figure 18. Additional Sequential Photographs, Test NYTCB-4.....	40
Figure 19. Additional Sequential Photographs, Test NYTCB-4.....	41
Figure 20. Additional Sequential Photographs, Test NYTCB-4.....	42
Figure 21. Documentary Photographs, Test NYTCB-4.....	43
Figure 22. Documentary Photographs, Test NYTCB-4.....	44
Figure 23. Impact Location, Test NYTCB-4.....	45
Figure 24. Vehicle Final Position and Trajectory Marks, Test NYTCB-4.....	46
Figure 25. System Damage, Test NYTCB-4.....	47
Figure 26. Barrier No. 4 Damage, Test NYTCB-4.....	48
Figure 27. Barrier No. 5 Damage, Test NYTCB-4.....	49
Figure 28. Barrier No. 5 Anchor Rod Damage, Test NYTCB-4.....	50
Figure 29. Joint 3-4 Connection Damage, Test NYTCB-4.....	51
Figure 30. Joint 4-5 Connection Damage, Test NYTCB-4.....	52
Figure 31. Joint 4-5 Connection Damage (Cont'd), Test NYTCB-4.....	53
Figure 32. Joint 5-6 Connection Damage, Test NYTCB-4.....	54
Figure 33. Joint 6-7 Connection Damage, Test NYTCB-4.....	55
Figure 34. Vehicle Damage, Test NYTCB-4.....	56
Figure 35. Vehicle Damage, Test NYTCB-4.....	57
Figure 36. Undercarriage Damage, Test NYTCB-4.....	58
Figure 37. Occupant Compartment Deformation, Test NYTCB-4.....	59
Figure A-1. Vehicle Mass Distribution, Test NYTCB-4.....	66
Figure B-1. Temporary Concrete Barrier Mill Specifications, Test NYTCB-4.....	68
Figure B-2. Temporary Concrete Barrier Certificate of Conformity, Test NYTCB-4.....	69
Figure B-3. Steel Pin Specifications, Test NYTCB-4.....	70
Figure C-1. Occupant Compartment Deformation Data – Set 1, Test NYTCB-4.....	72
Figure C-2. Occupant Compartment Deformation Data – Set 2, Test NYTCB-4.....	73

Figure C-3. Occupant Compartment Deformation Index (OCDI), Test NYTCB-4 ..... 74  
Figure C-4. External Vehicle Crush (NASS) - Front, Test NYTCB-4 ..... 75  
Figure C-5. External Vehicle Crush (NASS) - Side, Test NYTCB-4 ..... 76  
Figure D-1. Graph of 10 ms Average Longitudinal Deceleration (EDR-4), Test NYTCB-4 ..... 78  
Figure D-2. Graph of Longitudinal Occupant Impact Velocity (EDR-4), Test NYTCB-4 ..... 79  
Figure D-3. Graph of Longitudinal Occupant Displacement (EDR-4), Test NYTCB-4 ..... 80  
Figure D-4. Graph of 10 ms Average Lateral Deceleration (EDR-4), Test NYTCB-4 ..... 81  
Figure D-5. Graph of Lateral Occupant Impact Velocity (EDR-4), Test NYTCB-4 ..... 82  
Figure D-6. Graph of Lateral Occupant Displacement (EDR-4), Test NYTCB-4 ..... 83  
Figure D-7. Roll, Pitch, and Yaw Angular Displacements (EDR-4), Test NYTCB-4 ..... 84  
Figure D-8. Graph of 10 ms Average Longitudinal Deceleration (DTS), Test NYTCB-4 ..... 85  
Figure D-9. Graph of Longitudinal Occupant Impact Velocity (DTS), Test NYTCB-4 ..... 86  
Figure D-10. Graph of Longitudinal Occupant Displacement (DTS), Test NYTCB-4 ..... 87  
Figure D-11. Graph of 10 ms Average Lateral Deceleration (DTS), Test NYTCB-4 ..... 88  
Figure D-12. Graph of Lateral Occupant Impact Velocity (DTS), Test NYTCB-4 ..... 89  
Figure D-13. Graph of Lateral Occupant Displacement (DTS), Test NYTCB-4 ..... 90  
Figure D-14. Roll, Pitch, and Yaw Angular Displacements (DTS), Test NYTCB-4 ..... 91

**LIST OF TABLES**

Table 1. MASH Test Level 3 Crash Test Conditions ..... 9  
Table 2. MASH Evaluation Criteria for Crash Tests ..... 9  
Table 3. Weather Conditions, Test No. NYTCB-4..... 33  
Table 4. Summary of OIV, ORA, THIV, and PHD Values, Test NYTCB-4..... 38  
Table 5. Summary of MASH Safety Performance Evaluation Results ..... 61

## **1 INTRODUCTION**

### **1.1 Problem Statement**

Over the years, temporary concrete barrier (TCB) systems have been utilized to serve several functions, and include preventing motorists from encroaching into the work space within the work zones; providing positive protection for construction and maintenance workers as well as the associated operations; separating two-way or opposing traffic; shielding vehicles from roadside and median hazards; and separating pedestrians and bicyclists from vehicle traffic.

In general, these temporary concrete barrier (TCB) systems are used in free-standing configurations where the base of each barrier segment is placed on a paved surface but without physical attachment to that surface. Under high-energy impact scenarios, these free-standing, linked concrete barrier segments can be displaced laterally for several feet, thus allowing the barrier system to encroach into the work space. For narrow work areas, this barrier displacement could potentially result in workers being crushed between the barrier system and those objects located within the workspace. Free-standing barrier systems are also often used to shield vertical drop-offs, such as excavations adjacent to the roadway or at the exposed edge of a bridge deck. If TCBs are placed too close to a vertical drop-off and are displaced laterally, there exists a potential for the barrier system to fall onto workers in an excavation or below a bridge, or even onto traffic under the bridge.

Various anchorage and stiffening systems have been incorporated into selected TCB systems in order to reduce barrier deflections and allow their use in restricted work zones with confined space behind the barrier system and/or limited lane width in front of the barrier system. Some of these systems have included the use of stiffening beams placed on the back side of the barriers and across the joints, the placement of vertical pins or rods through either the front toe or

both toes of the barrier and into the pavement or bridge deck surface, as well as the use of an anchorage system that connects the joint hardware to the deck surface. Although various vertical pinning methods have been successfully developed for anchoring TCBs to paved surfaces, including concrete bridge decks, the installation process is often considered to be time-consuming, costly, and ultimately may result in damage to the bridge deck.

Over the last decade, the New York State Department of Transportation (NYSDOT) sponsored considerable research for the crash testing and evaluation of a New Jersey-shape temporary concrete barrier system used in both free-standing and stiffened configurations and with the barrier ends both pinned and unpinned to the pavement surface (1-3). These crash testing programs were conducted according to the Test Level 3 (TL-3) safety performance criteria found either in the National Cooperative Highway Research Program (NCHRP) Report No. 350 (4) or the Manual for Assessing Safety Hardware (MASH) (5). However, it should be noted that these research programs did not explore the use of vertical steel pins placed through the back-side toe of New York State's New Jersey-shape temporary concrete barrier system and inserted into drilled holes within a rigid concrete surface. For TCBs located adjacent to vertical drop-offs, the NYSDOT has deemed it desirable to utilize vertical pins through the back-side toe in order to reduce barrier deflections as well as to reduce the need for workers to be positioned on the traffic-side face of the TCBs while anchoring the barrier segments.

As a result, there existed a need for determining whether the New York State's New Jersey-shape, temporary concrete barrier system could be pinned throughout its length and only on the back-side face of the barrier. In order to reduce construction costs and damage to bridge decks, an investigation was undertaken to evaluate whether barrier deflections would be maintained to reasonable levels with vertical pins placed in every other barrier segment.

## **1.2 Research Objective**

The objectives of this research project were to evaluate the deflection performance and confirm satisfactory safety performance of pinned options of NYSDOT's New Jersey-shape, temporary concrete barrier system. NYSDOT officials were confident that the barrier system would meet all of the impact safety standards. However, the NYSDOT wanted to evaluate the TCB system using the TL-3 safety performance criteria set forth in MASH, which results in a 13.5 percent increase in impact severity over that provided in NCHRP Report No. 350.

## **1.3 Scope**

The research objective was achieved through the completion of several tasks. First, a full-scale vehicle crash test was performed on the pinned temporary concrete barrier system with alternating segments anchored to the pavement surface. The crash test utilized a pickup truck, weighing approximately 5,000 lbs (2,268 kg), as recommended in MASH guidelines (5). The target impact conditions for the test were an impact speed of 62 mph (100 km/h) and an impact angle of 25 degrees. Next, the test results were analyzed, evaluated, and documented. Finally, conclusions and recommendations were made that pertain to the safety performance of the pinned temporary concrete barrier system.

## 2 LITERATURE REVIEW

Previous testing on the NYSDOT TCB system was conducted by the Texas Transportation Institute (TTI) and the Midwest Roadside Safety Facility (MwRSF) (1-3). At TTI, the TCB system was evaluated according to the criteria provided in NCHRP Report No. 350 (4), while at MwRSF the TCB system was evaluated according to the criteria presented in MASH (5).

In 1999, TTI tested a free-standing version of the NYSDOT TCB with unpinned ends (1). In test no. 473220-7, a 4,575-lb (2,075-kg) pickup truck impacted the ten barrier system 3 ft - 11 in. (1.2 m) upstream of the joint between barrier segment nos. 3 and 4 at a speed of 60.9 mph (98.0 km/h) and at an angle of 26.3 degrees. During the impact, three of the barrier joints failed, causing the barrier at the point of impact to overturn. Subsequently, the vehicle overrode the barrier and rolled over. Thus, the test was determined to be unacceptable according to the NCHRP Report No. 350 requirements, since the vehicle did not remain upright after collision with the system. The joint failure was subsequently attributed to substandard welding in the connection joints.

In 2001, TTI retested the properly fabricated unpinned NYSDOT TCB system (2). It should be noted that the end barrier sections were unpinned as well. During test no. 473220-14, a 4,577-lb (2,076-kg) pickup truck impacted the ten barrier system 4 ft - 6 in. (1.38 m) upstream of the joint between barrier segment nos. 3 and 4 at a speed of 62.6 mph (100.8 km/h) and at an angle of 25.6 degrees. During the impact, the vehicle was redirected smoothly, and the test was determined to be acceptable according to the NCHRP Report No. 350 requirements. The barrier system experienced 50 in. (1,270 mm) of dynamic deflection and 50 in. (1,270 mm) of permanent set deflection. During the test, the upstream end was pulled 5 13/16 in. (148 mm)

longitudinally downstream, while the downstream end was displaced 3/16 in. (5 mm) longitudinally upstream, or toward the impact point. The noted lateral barrier deflections would be correlated to the unpinned section ends. It was NYSDOT's concern over this large barrier deflection that caused the state agency to contract with MwRSF to conduct the barrier stiffening research noted below.

In 2008, MwRSF crash tested three different versions of NYSDOT's TCB system (3). The research study included three full-scale vehicle crash tests with 2270P pickup trucks conducted in accordance to the TL-3 evaluation criteria published in MASH. In all three tests, the first and last barrier sections were anchored to the concrete.

The first test, test no. NYTCB-1, consisted of stiffening three joints between barrier nos. 4 and 7 with 6-in. x 6-in. x 3/16-in. (152-mm x 152-mm x 4.8-mm) box beam sections. In this test, a 5,016-lb (2,275-kg) pickup truck impacted the ten barrier system essentially at the target location, which was 51 3/16 in. (1.3 m) upstream from the downstream end of barrier no. 4 at a speed of 61.8 mph (99.5 km/h) and at an angle of 24.6 degrees. During the impact, the vehicle was redirected smoothly, and the test was determined to be acceptable according to MASH requirements. The barrier system with anchored ends experienced 27 5/8 in. (700 mm) of dynamic deflection and 26 in. (660 mm) of permanent set deflection.

The second test, test no. NYTCB-2, consisted of an unstiffened version of the NYSDOT TCB system with anchored ends. In this test, a 5,024-lb (2,279-kg) pickup truck impacted the ten barrier system essentially at the target location, which was 51 3/16 in. (1.3 m) upstream from the downstream end of barrier no. 4 at a speed of 61.2 mph (98.5 km/h) and at an angle of 25.8 degrees. During the impact, the vehicle was redirected smoothly, and the test was determined to be acceptable according to MASH requirements. The barrier system with anchored ends



experienced 40 5/16 in. (1,023 mm) of dynamic deflection and 39½ in. (1,003 mm) of permanent set deflection.

The third test, test no. NYTCB-3, consisted of stiffening six joints between barrier nos. 2 and 8 with 6-in. x 8-in. x ¼-in. (152-mm x 203-mm x 6.4-mm) box beam sections. In addition, this system was installed with the back side of the barrier sections placed 12 in. (305 mm) away from a simulated bridge deck edge. In this test, a 5,001-lb (2,268-kg) pickup truck impacted the ten barrier system essentially at the target location, which was 51 3/16 in. (1.3 m) upstream from the downstream end of barrier no. 4 at a speed of 63.5 mph (102.2 km/h) and at an angle of 24.4 degrees. During the test, the vehicle was redirected smoothly, and the test was determined to be acceptable according to MASH requirements. The barrier system with anchored ends experienced 30⅞ in. (784 mm) of dynamic deflection and 26 in. (660 mm) of permanent set deflection.

### 3 TEST REQUIREMENTS AND EVALUATION CRITERIA

#### 3.1 Test Requirements

Longitudinal barriers, such as temporary concrete barriers, must satisfy impact safety standards in order to be accepted by the Federal Highway Administration (FHWA) for use on National Highway System (NHS) construction projects or as a replacement for existing designs not meeting current safety standards. According to TL-3 of MASH, longitudinal barriers must be subjected to two full-scale vehicle crash tests. The two full-scale crash tests are as follows:

1. Test Designation 3-10 consisting of a 2,425-lb (1,100-kg) passenger car impacting the barrier system at a nominal speed and angle of 62 mph (100 km/h) and 25 degrees, respectively.
2. Test Designation 3-11 consisting of a 5,000-lb (2,268-kg) pickup truck impacting the barrier system at a nominal speed and angle of 62 mph (100 km/h) and 25 degrees, respectively.

A rigid, F-shape bridge rail was successfully impacted by a small car weighing 1,800 lbs (893 kg) at 60.1 mph (96.7 km/h) and 21.4 degrees according to the American Association of State Highway and Transportation Officials (AASHTO) *Guide Specifications for Bridge Railings* (6-7). In the same manner, rigid New Jersey safety shape barriers struck by small cars have also been shown to meet safety performance standards (8-9). In addition, a New Jersey safety shape barrier was impacted by a passenger car weighing 2,579 lbs (1,170 kg) at 60.8 mph (97.9 km/h) and 26.1 degrees according to the TL-3 standards set forth in MASH (10). Furthermore, temporary New Jersey safety shape concrete median barriers have experienced only slight barrier deflections when impacted by small cars and behave similar to rigid barriers (11). Thus, if the NYSDOT's pinned TCB system does not exhibit significant roll when subjected to the pickup truck impact condition, then it may not be necessary to conduct the 2,425-lb (1,100-kg) passenger car test due to expectations for only minor barrier rotations. However, if the pickup

truck impact into the barrier system induces significant barrier rotations, then it also may be necessary to conduct the passenger car test in order to evaluate the propensity for vehicular instabilities upon redirection. The test conditions for TL-3 longitudinal barriers are summarized in Table 1.

For this crash testing program, the NYSDOT's primary objective was to evaluate the deflection performance of a pinned version of the NYSDOT's TCB system when subjected to high-speed, high-energy, pickup truck impacts.

### **3.2 Evaluation Criteria**

According to MASH, the evaluation criteria for full-scale vehicle crash testing are based on three appraisal areas: (1) structural adequacy; (2) occupant risk; and (3) vehicle trajectory after collision. Criteria for structural adequacy are intended to evaluate the ability of the barrier to contain, redirect, or allow controlled vehicle penetration in a predictable manner. Occupant risk evaluates the degree of hazard to occupants in the impacting vehicle. Vehicle trajectory after collision is a measure of the potential for the post-impact trajectory of the vehicle to cause subsequent multi-vehicle accidents. This criterion also indicates the potential safety hazard for the occupants of other vehicles or the occupants of the impacting vehicle when subjected to secondary collisions with other fixed objects. These three evaluation criteria are summarized in Table 2 and defined in greater detail in MASH (5). The full-scale vehicle crash tests were conducted and reported in accordance with the procedures provided in MASH.

In addition to the standard occupant risk measures, the Post-Impact Head Deceleration (PHD) and Theoretical Head Impact Velocity (THIV) were also determined and reported on the test summary sheets. Additional discussion on PHD and THIV is provided in Reference 5.

**Table 1. MASH Test Level 3 Crash Test Conditions**

Test Article	Test Designation	Test Vehicle	Impact Conditions			Evaluation Criteria <sup>1</sup>
			Speed		Angle (deg)	
			mph	km/h		
Longitudinal Barrier	3-10	1100C	62	100	25	A,D,F,H,I
	3-11	2270P	62	100	25	A,D,F,H,I

<sup>1</sup> Evaluation criteria explained in Table 2.

**Table 2. MASH Evaluation Criteria for Crash Tests**

Structural Adequacy	A. Test article should contain and redirect the vehicle or bring the vehicle to a controlled stop; the vehicle should not penetrate, underide, or override the installation although controlled lateral deflection of the test article is acceptable.		
Occupant Risk	D. Detached elements, fragments or other debris from the test article should not penetrate or show potential for penetrating the occupant compartment, or present an undue hazard to other traffic, pedestrians, or personnel in a work zone. Deformations of, or intrusions into, the occupant compartment should not exceed limits set forth in Section 5.3 and Appendix E of MASH.		
	F. The vehicle should remain upright during and after collision. The maximum roll and pitch angles are not to exceed 75 degrees.		
	H. Occupant Impact Velocities (OIV) (see Appendix A, Section A5.3 of MASH for calculation procedure) should satisfy the following limits:		
	Occupant Impact Velocity Limits, ft/s (m/s)		
	Component	Preferred	Maximum
	Longitudinal and Lateral	30 ft/s (9.1 m/s)	40 ft/s (12.2 m/s)
I. The Occupant Ridedown Acceleration (ORA) (see Appendix A, Section A5.3 of MASH for calculation procedure) should satisfy the following limits:			
Occupant Ridedown Acceleration Limits (g's)			
Component	Preferred	Maximum	
Longitudinal and Lateral	15.0 g's	20.49 g's	

## 4 TEST CONDITIONS

### 4.1 Test Facility

The testing facility is located at the Lincoln Air Park on the northwest side of the Lincoln Municipal Airport and is approximately 5 mi (8.0 km) northwest of the University of Nebraska-Lincoln.

### 4.2 Vehicle Tow and Guidance System

A reverse cable tow system with a 1:2 mechanical advantage was used to propel the test vehicle. The distance traveled as well as the speed of the tow vehicle were one-half of that expected for the test vehicle. The test vehicle was released from the tow cable before impact with the barrier system. A digital speedometer on the tow vehicle increases the accuracy of the test vehicle impact speed.

A vehicle guidance system developed by Hinch (12) was used to steer the test vehicle. A guide-flag, attached to the right-front wheel and the guide cable, was sheared off before impact with the barrier system. The 3/8-in. (9.5-mm) diameter guide cable was tensioned to approximately 3,500 lbf (15.6 kN) and supported both laterally and vertically every 100 ft (30.48 m) by hinged stanchions. The hinged stanchions stood upright while holding up the guide cable, but as the vehicle was towed down the line, the guide-flag struck and knocked each stanchion to the ground. For test no. NYTCB-4, the vehicle guidance system was 1,100 ft (335 m) long.

### 4.3 Test Vehicle

For test no. NYTCB-4, a 2002 Dodge Ram 1500 Quad Cab pickup truck was used as the test vehicle. The test inertial and gross static weights were 5,002 lbs (2,269 kg) and 5,172 lbs (2,346 kg), respectively. The test vehicle is shown in Figure 1, and vehicle dimensions are shown in Figure 2.



Figure 1. Test Vehicle, Test NYTCB-4

Date: 1/9/2009 Test Number: NYTCB-4 Model: Ram 1500 Q.C.  
Make: Dodge Vehicle I.D.#: 3B7HA18N72G100780  
Tire Size: 265/70 R17 Year: 2002 Odometer: 146121

\*(All Measurements Refer to Impacting Side)

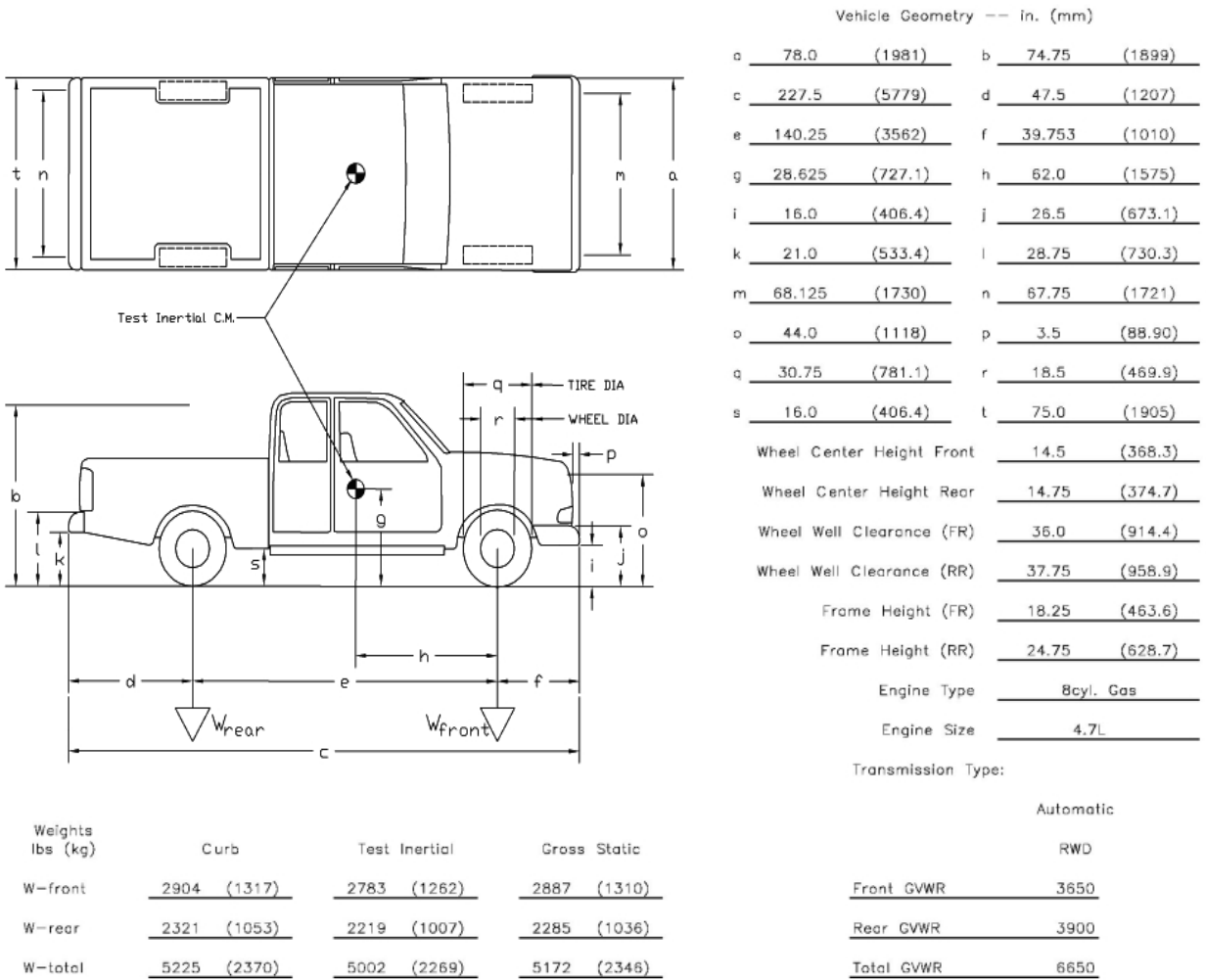

Note any damage prior to test: none

Figure 2. Vehicle Dimensions, Test NYTCB-4

The Suspension Method (13) was used to determine the vertical component of the center of gravity (c.g.) for the pickup truck. This method is based on the principle that the c.g. of any freely suspended body is in the vertical plane through the point of suspension. The vehicle was suspended successively in three positions, and the respective planes containing the c.g. were established. The intersection of these planes pinpointed the location of the c.g. The longitudinal component of the c.g. was determined using the measured axle weights. The location of the final center of gravity is shown in Figures 2 and 3. The c.g. calculations and ballast information are shown in Appendix A. It should be noted that a non-instrumented dummy was positioned in the left-front seat of vehicle and held in place with the onboard safety restraint system.

Square, black and white checkered targets were placed on the vehicle to aid in the analysis of the high-speed AOS videos, as shown in Figure 3. Round, checkered targets were placed on the center of gravity on the left-side door, the right-side door, and the roof of the vehicle. The remaining targets were located for reference so that they could be viewed from the high-speed cameras for video analysis.

The front wheels of the test vehicle were aligned for camber, caster, and toe-in values of zero so that the vehicles would track properly along the guide cable. A 5B flash bulb was mounted near the middle of the vehicle windshield to pinpoint the time of impact with the barrier system on the high-speed video footage. The flash bulb was fired by a pressure tape switch mounted at the impact corner of the bumper. A remote controlled brake system was installed in the test vehicle so the vehicle could be brought safely to a stop after the test.



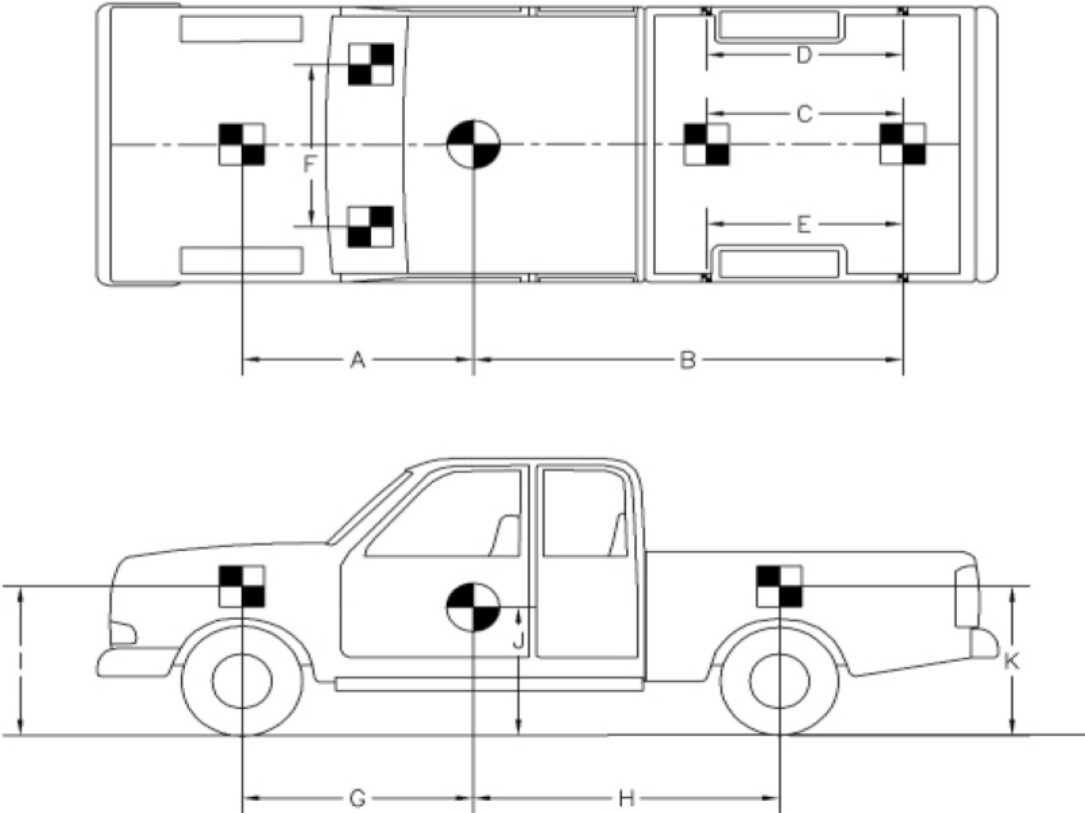

TEST #: NYTCB-4					
TARGET GEOMETRY -- in. (mm)					
A	73.0	(1854)	E	69.0	(1753)
B	99.25	(2521)	F	48.25	(1226)
C	42.0	(1067)	G	62.0	(1575)
D	69.25	(1759)	H	78.25	(1988)
			I	40.25	(1022)
			J	28.625	(727)
			K	42.0	(1067)

Figure 3. Target Geometry, Test NYTCB-4

## **4.4 Data Acquisition Systems**

### **4.4.1 Accelerometers**

One triaxial piezoresistive accelerometer system with a range of  $\pm 500$  g's was used to measure the acceleration in the longitudinal, lateral, and vertical directions at a sample rate of 10,000 Hz. The environmental shock and vibration sensor/recorder system, Model EDR-4M6, was developed by Instrumented Sensor Technology (IST) of Okemos, Michigan and includes three differential channels as well as three single-ended channels. The EDR-4 was configured with 24 MB of RAM memory and a 1,667 Hz anti-aliasing filter. "EDR4COM" and "DynaMax Suite" computer software programs and a customized Microsoft Excel worksheet were used to analyze and plot the accelerometer data.

An additional accelerometer system was used to measure the acceleration in the longitudinal, lateral, and vertical directions at a sample rate of 10,000 Hz. The environmental shock and vibration sensor/recorder system, a two-arm piezoresistive accelerometer, was developed by Endevco of San Juan Capistrano, California. Three accelerometers were used to measure each of the longitudinal, lateral, and vertical accelerations independently. Data was collected using a Sensor Input Module (SIM), Model TDAS3-SIM-16M, which was developed by Diversified Technical Systems, Inc. (DTS) of Seal Beach, California. The SIM was configured with 16 MB SRAM memory and 8 sensor input channels with 250 kB SRAM/channel. The SIM was mounted on a TDAS3-R4 module rack. The module rack is configured with isolated power/event/communications, 10BaseT Ethernet and RS232 communication, and an internal backup battery. Both the SIM and module rack are crashworthy. "DTS TDAS Control" computer software program and a customized Microsoft Excel worksheet were used to analyze and plot the accelerometer data.

#### **4.4.2 Rate Transducers**

An Analog Systems 3-axis rate transducer with a range of 1,200 degrees/sec in each of the three directions (pitch, roll, and yaw) was used to measure the rates of motion of the test vehicles. The rate transducer was mounted inside the body of the EDR-4M6 and recorded data at 10,000 Hz to a second data acquisition board inside the EDR-4M6 housing. The raw data measurements were then downloaded, converted to the appropriate Euler angles for analysis, and plotted. “EDR4COM” and “DynaMax Suite” computer software programs and a customized Microsoft Excel worksheet were used to analyze and plot the rate transducer data.

An additional angle rate sensor, the ARS-1500, has a range of 1,500 degrees/sec in each of the three directions (roll, pitch, and yaw) and was used to measure the rates of rotation of the test vehicle. The angular rate sensor was mounted on an aluminum block inside the test vehicle at the center of gravity and recorded data at 10,000 Hz to the SIM. The raw data measurements were then downloaded, converted to the proper Euler angles for analysis, and plotted. “DTS TDAS Control” computer software program and a customized Microsoft Excel worksheet were used to analyze and plot the angular rate sensor data.

#### **4.4.3 Pressure Tape Switches**

For test no. NYTCB-4, five pressure-activated tape switches, spaced at 6 ft - 6 3/4 in. (2 m) intervals, were used to determine the speed of the vehicle before impact. Each tape switch fired a strobe light which sent an electronic timing signal to the data acquisition system as the left-front tire of the test vehicle passed over it. Test vehicle speed was determined from electronic timing mark data recorded using TestPoint software. Strobe lights and high-speed video analysis are used only as a backup in the event that vehicle speed cannot be determined from the electronic data.

#### **4.4.4 High Speed Photography**

For test no. NYTCB-4, two high-speed AOS VITcam digital video cameras, three high-speed AOS X-PRI digital video cameras, three JVC digital video cameras, and three Canon digital video cameras were used to film the crash test. Camera details, camera operating speeds, lens information, and a schematic of the camera locations are shown in Figure 4. The AOS videos were analyzed using the ImageExpress MotionPlus software. Actual camera speed and divergence factors were considered in the analysis of the high-speed videos.

	No.	Type	Operating Speed (frames/sec)	Lens	Lens Setting
High-Speed Video	2	VITcam CTM	500	Cosmicar 12.5 mm Fixed	-
	3	VITcam CTM	500	Sigma 24-70	1/2 way between 35 & 50
	5	X-PRI	500	Sigma 70-200	100
	6	X-PRI	500	Sigma 50 mm Fixed	-
	7	X-PRI	500	Sigma 24-135	24
Digital Video	1	JVC - GZ-MC500 (Everio)	29.97		
	3	JVC - GZ-MC40u (Everio)	29.97		
	4	JVC - GZ-MC40u (Everio)	29.97		
	7	Canon-ZR90	29.97		
	8	Canon-ZR90	29.97		
	2	Canon-ZR90	29.97		

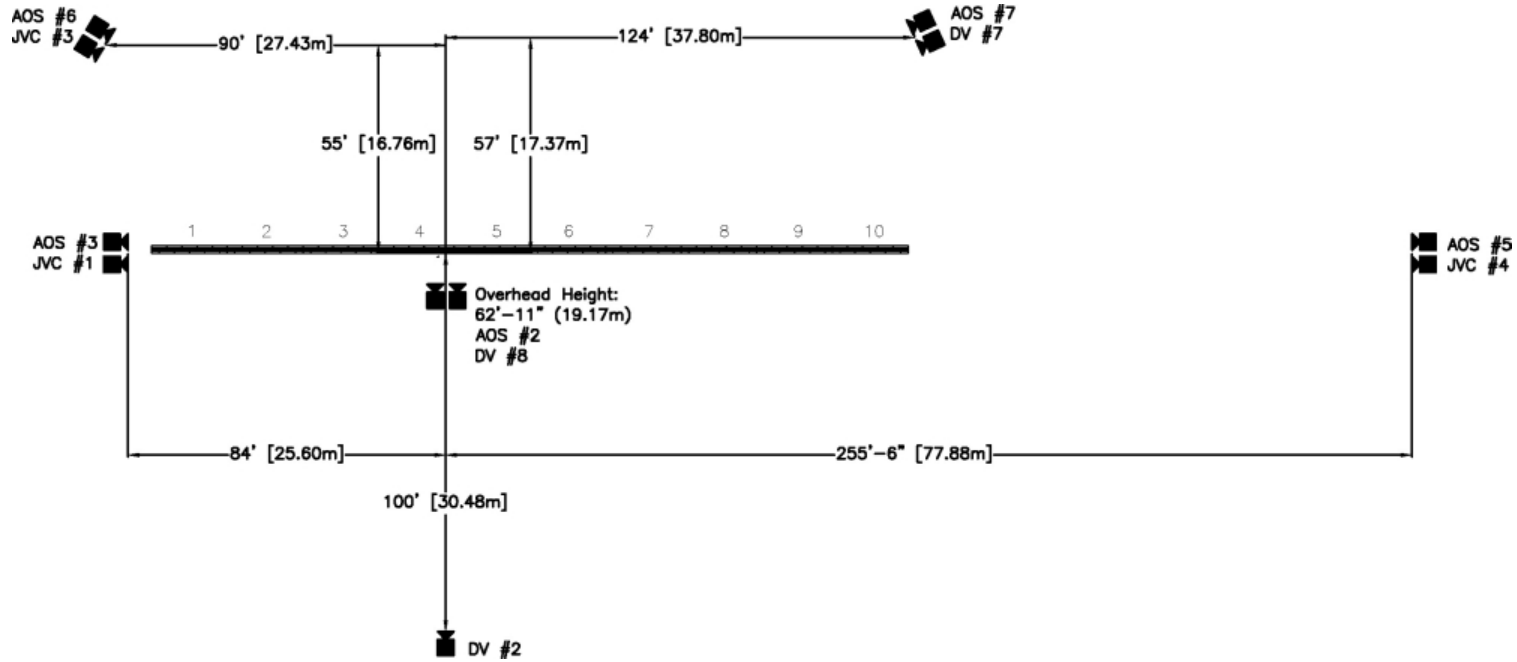

Figure 4. Camera Locations, Test NYTCB-4

## 5 DESIGN DETAILS

The test installation was 200 ft (60.96 m) long, consisting of ten temporary concrete barrier sections in an anchored configuration, as shown in Figures 5 through 13. The 20-ft (6.10-m) long, temporary concrete barrier sections were placed on the rigid concrete surface with barrier section nos. 1, 3, 5, 7, and 9 attached to the concrete surface. Photographs of the test installation are shown in Figures 14 through 16. Purchase documentation, material specifications, mill certifications, and/or certificates of conformity for the system materials are shown in Appendix B.

The concrete used for the barrier sections consisted of a concrete mix with a minimum 28-day compressive strength of 3,000 psi (21.0 MPa). A minimum concrete cover of 1½ in. (38 mm) was used along all rebar in the barrier. All of the steel reinforcement in the barrier was ASTM A615 Grade 60 rebar. The section reinforcement details are shown in Figures 5 through 7 and 12.

Section reinforcement consisted of four No. 6 longitudinal bars, eight No. 4 bars for the vertical stirrups, four No. 6 lateral bars, and nine No. 4 bars for the anchor hole reinforcement loops. Longitudinal rebar consisted of two upper bars and two lower bars, all of which was 19 ft (5.79 m) long. The vertical spacing of the lower and upper longitudinal bars was 6¾ in. (171 mm) and 2 ft – 1½ in. (648 mm) from the ground to their centers, respectively. The vertical stirrup spacing varied longitudinally, as shown in Figure 7. The upper and lower lateral bars were 6 in. (152 mm) and 14 in. (356 mm) long, respectively. The vertical spacing of the lower and upper lateral bars was 7½ in. (191 mm) and 18¾ in. (476 mm) from the ground to their centers, respectively. The 34 1/16-in. (865-mm) long anchor hole loops were bent into a U-shape, and they reinforced the anchor hole area, as shown in Figures 7 and 12.

The barrier sections used a connection key, as shown in Figures 8 through 11. The connection key assembly consisted of ½-in. (13-mm) thick, ASTM A36 steel plates welded together to form the key shape. Two stiffeners were welded to the top plate with their interior faces in contact with the I-beam shape and located 5/16 in. (8 mm) up from the ends of the top plate, as shown in Figures 8 and 9.

A connector key was configured at each end of the barrier section, as shown in Figure 7. The connector key consisted of one ASTM A500 steel tube and three ASTM A36 steel plates. Three U-shaped plates were welded on the sides of the tube, as shown in Figure 10. A connection key was inserted into the steel tubes of two adjoining sections to form the connection, as shown in Figure 11.

Barrier section nos. 1, 3, 5, 7, and 9 were pinned to the rigid concrete pavement with four 1-in. (25-mm) diameter by 15½-in. (394-mm) long, ASTM A36 (hot rolled) steel rods. The steel rods or pins were passed through the precast holes on the back-side toe of the barrier sections, as shown in Figure 6. Each anchor rod was then inserted into a 1⅛-in. (29-mm) diameter, drilled hole in the rigid concrete surface using an embedment depth of 5 in. (127 mm), as shown in Figure 5.

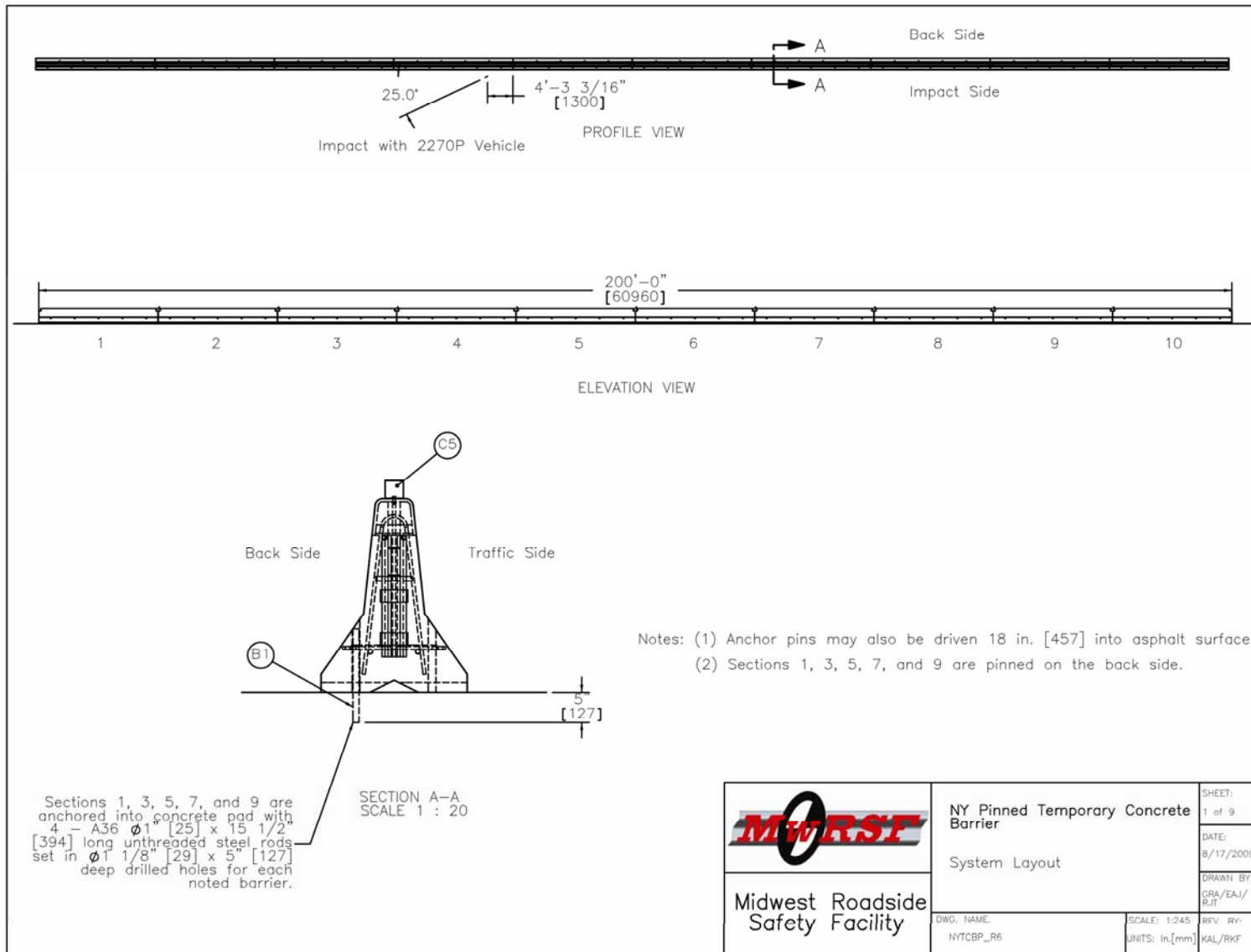

Figure 5. Pinned Temporary Concrete Barrier System Layout, Test NYTCB-4



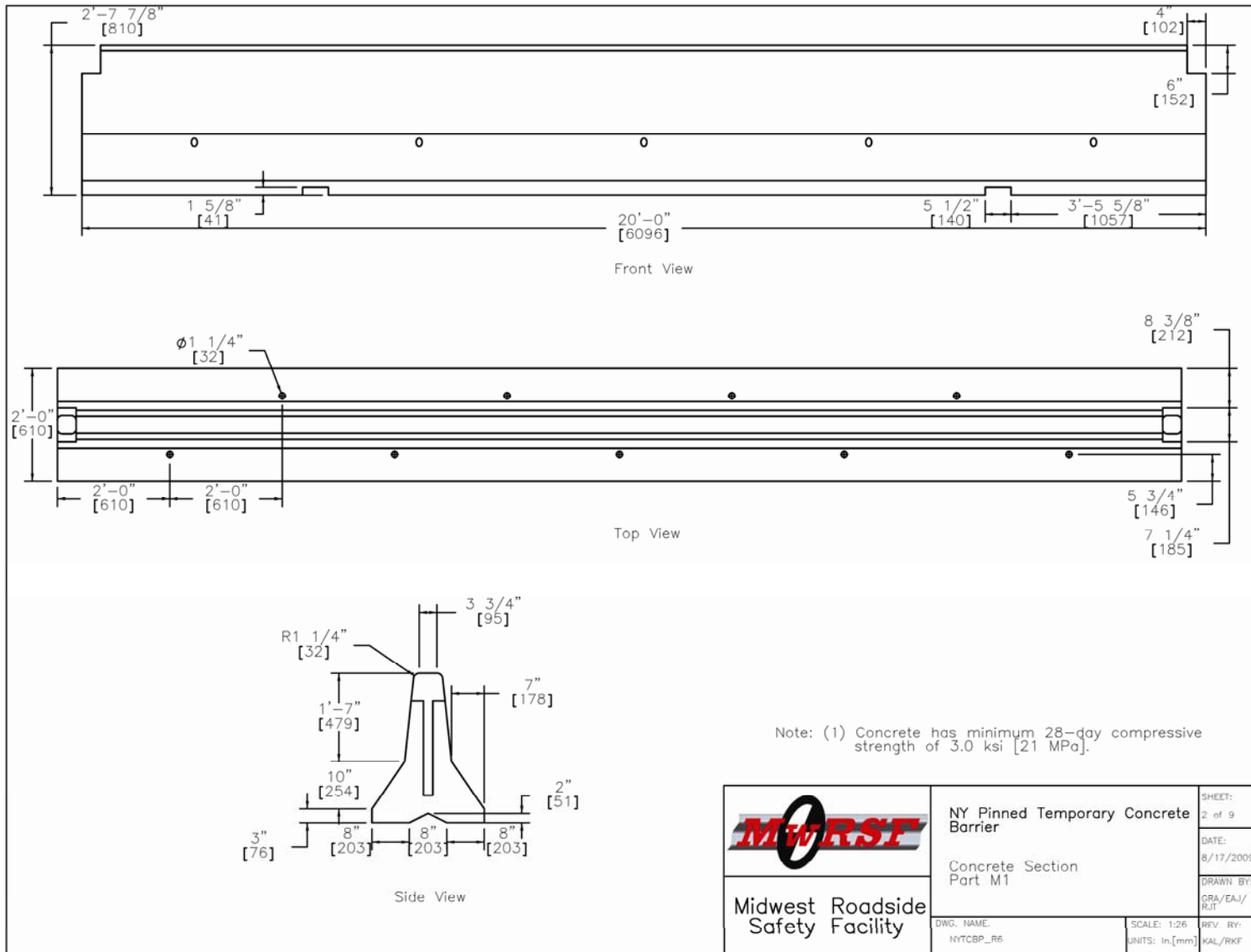

Figure 6. Temporary Concrete Barrier Details, Test NYTCB-4

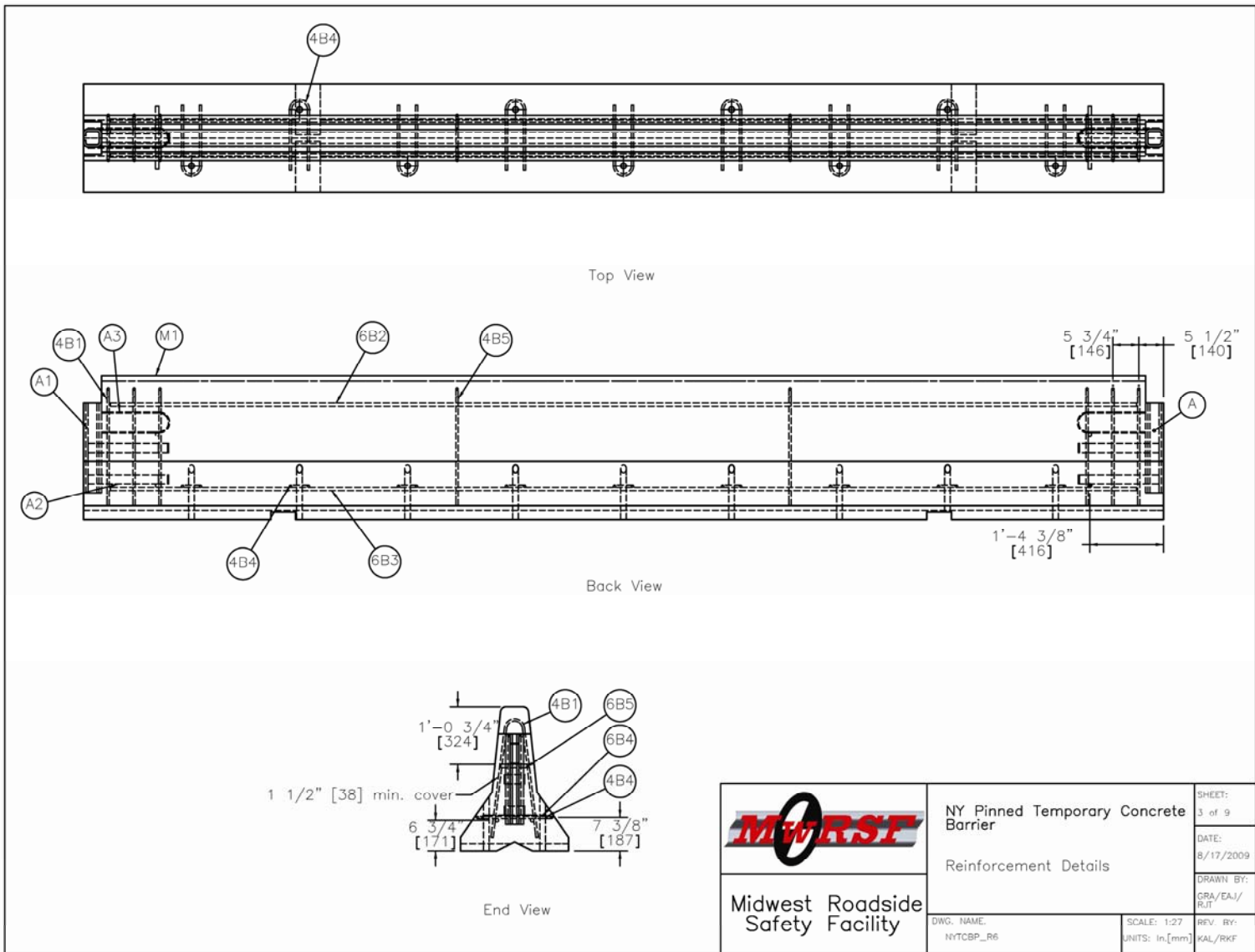

Figure 7. Temporary Concrete Barrier Reinforcement Details, Test NYTCB-4

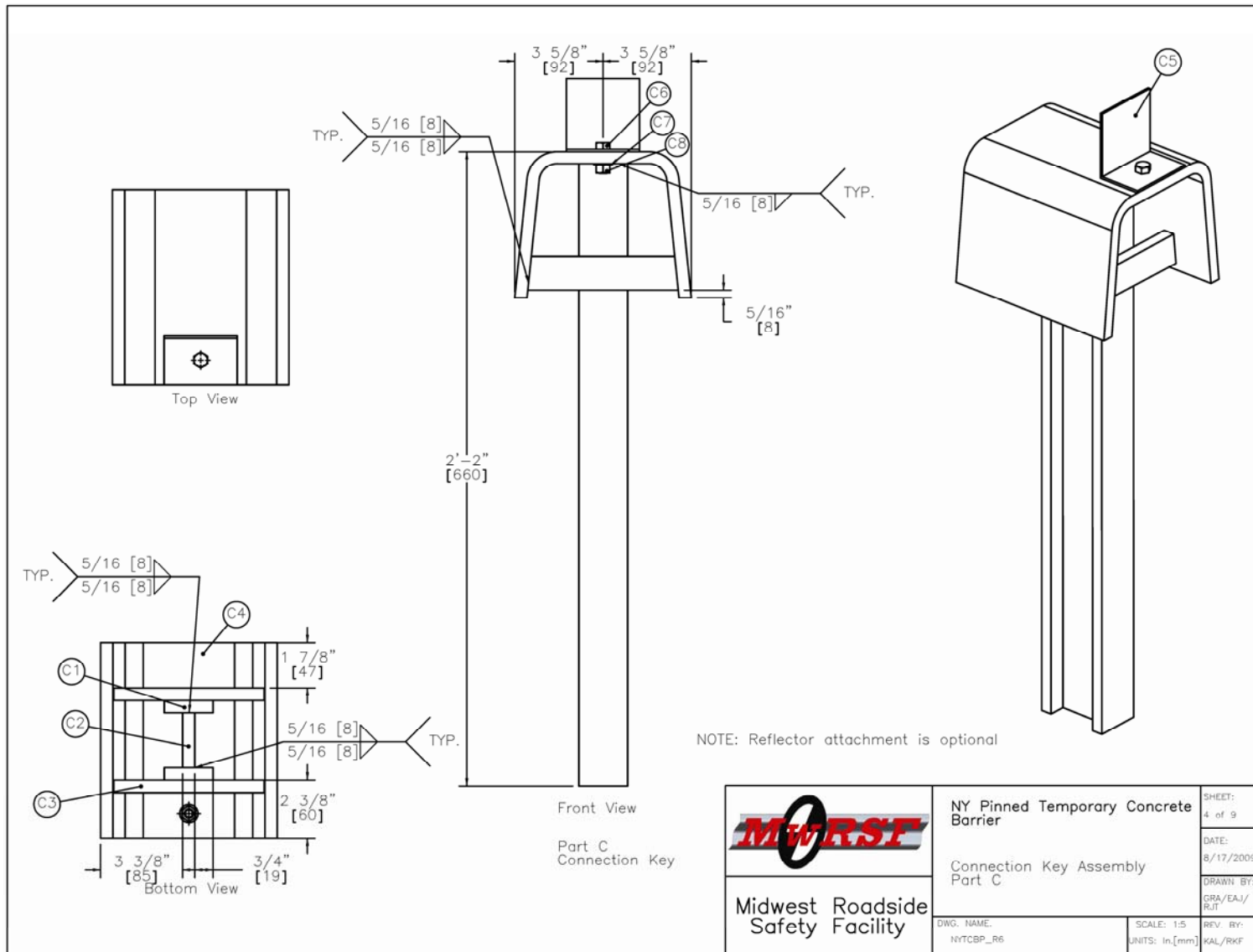

Figure 8. Connection Key Assembly Details, Test NYTCB-4

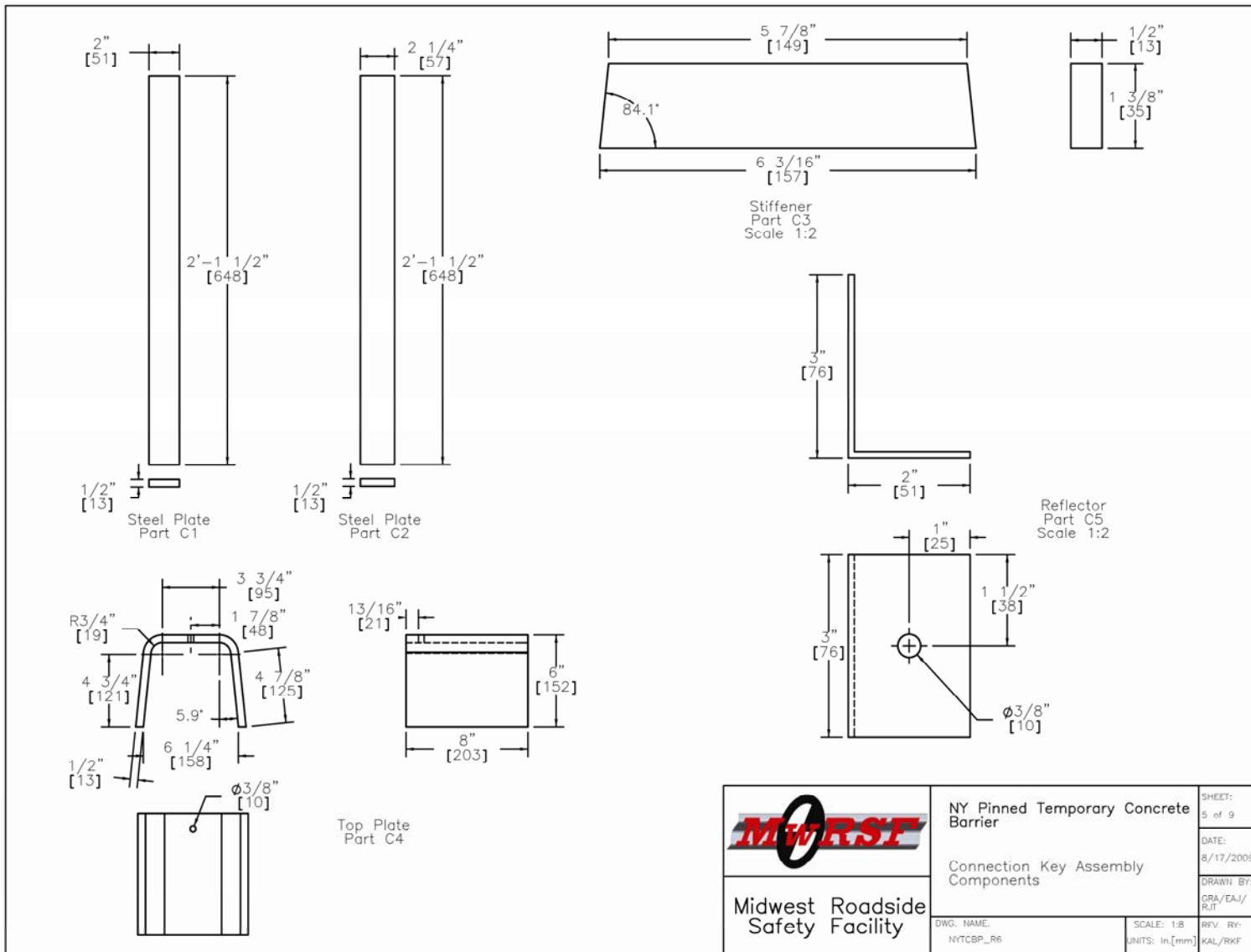

Figure 9. Connection Key Assembly Details, Test NYTCB-4

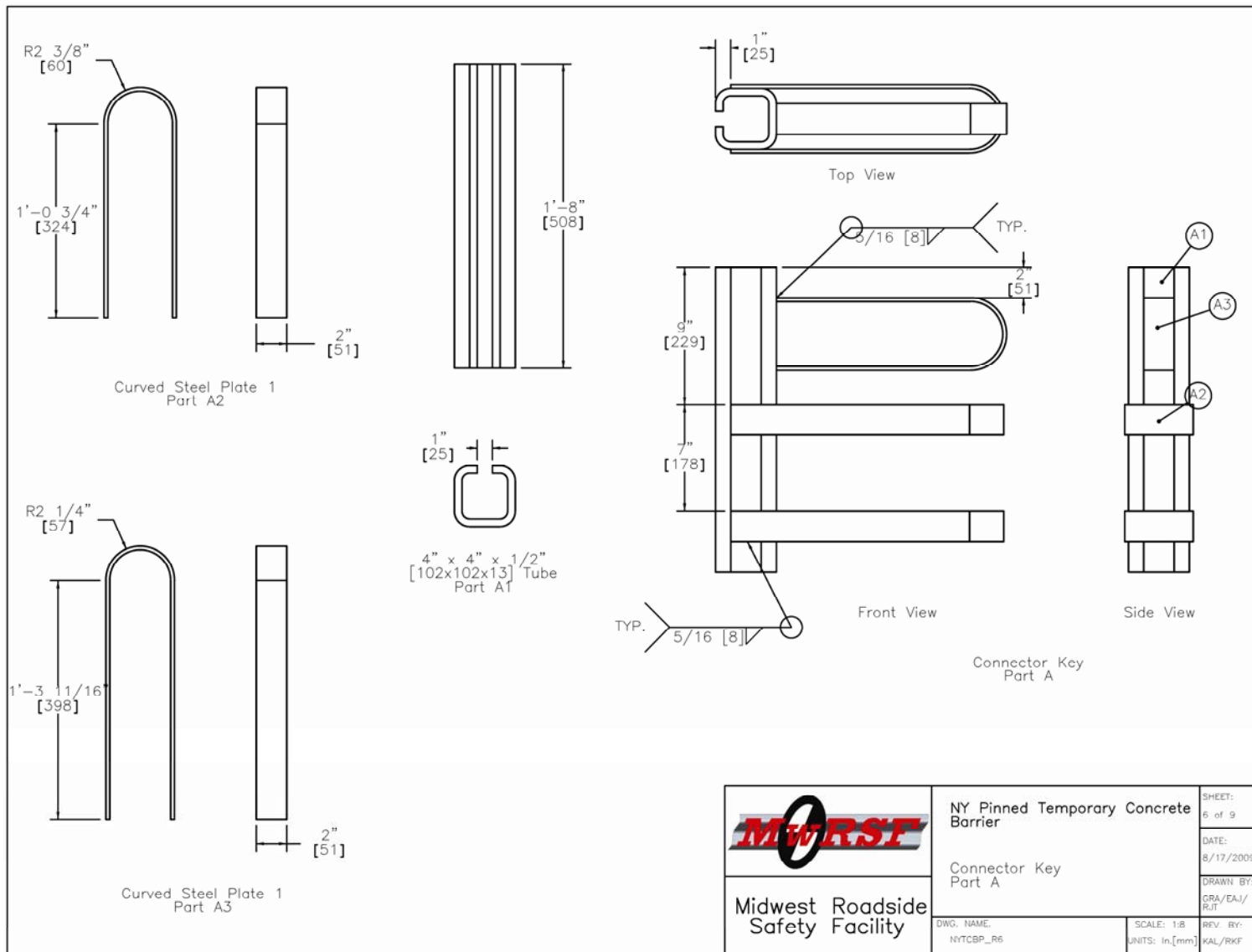

Figure 10. Temporary Concrete Barrier Connector Assembly Details, Test NYTCB-4

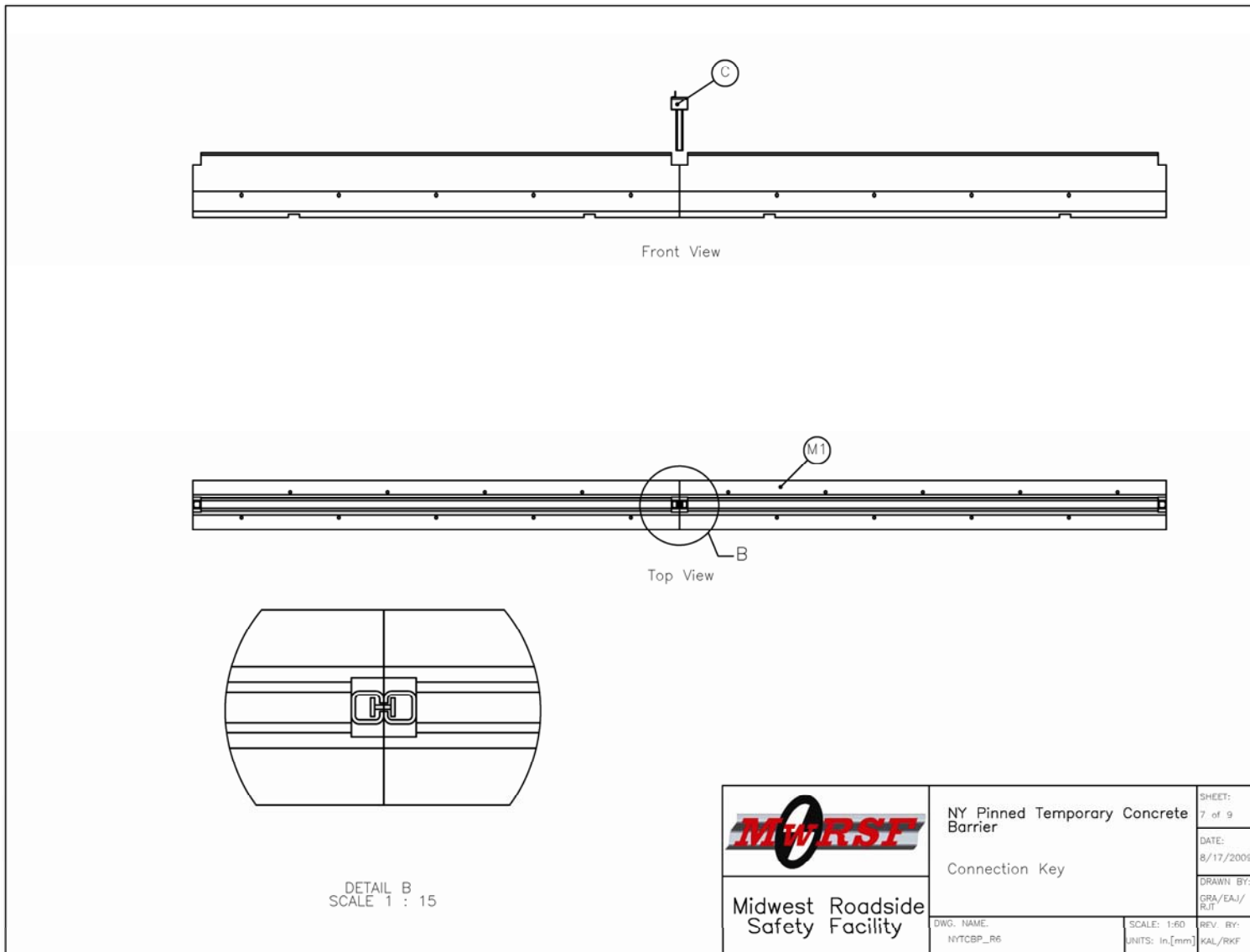

Figure 11. Temporary Concrete Barrier Connection Details, Test NYTCB-4

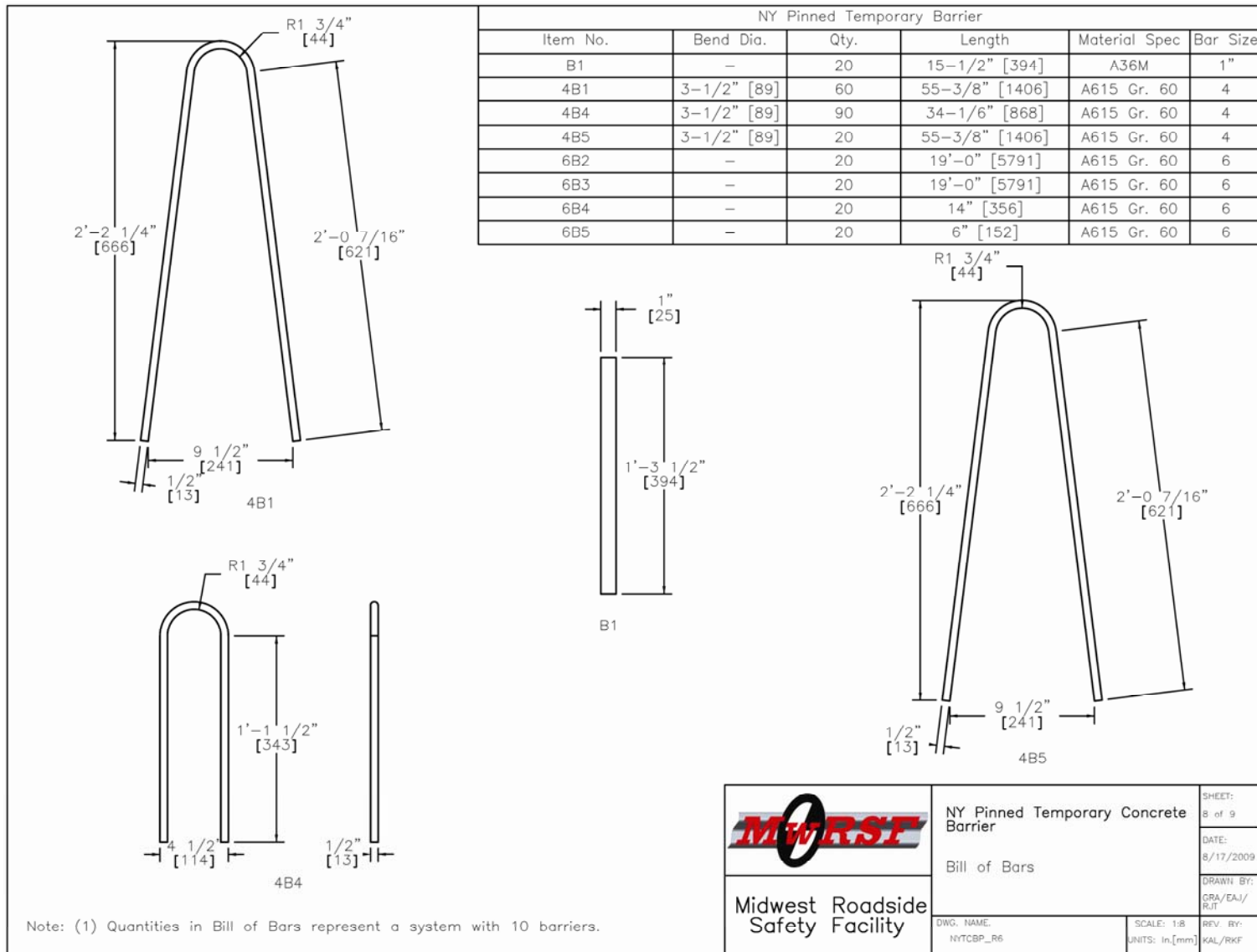

Figure 12. Bill of Bars, Test NYTCB-4

New York Pinned Temporary Concrete Barrier				
Item No.	QTY.	Description	Material Spec	
4B1	60	Rebar 4B1	A615 60	
4B4	18	Rebar 4B4	A615 60	
4B5	20	Rebar 4B5	A615 60	
6B2	20	Rebar 6B2	A615 60	
6B3	20	Rebar 6B3	A615 60	
6B4	20	Rebar 6B4	A615 60	
6B5	20	Rebar 6B5	A615 60	
A1	20	Steel Tube - 4"x4"x1/2" thick x 20" long	A500	
A2	40	Steel Plate	A36	
A3	20	Steel Plate	A36	
B1	20	1" Dia. x 15.5" Unthreaded Rod	A36	
C1	18	Steel Plate	A36	
C2	9	Steel Plate	A36	
C3	18	Steel Plate-1/2"	A36	
C4	9	Steel Plate- 1/2"	A36	
C5	9	Steel Plate	A36	
C6	9	7/16 - 14 UNC x 1" Grade A325 Bolt	A325	
C7	9	7/16" Dia. Lock Washer	F436 Gr. 1	
C8	9	7/16" Dia. Hex Nut	A563	
M1	10	Concrete Section	Min fc = 3,000 psi	
		 Midwest Roadside Safety Facility	NY Pinned Temporary Concrete Barrier Bill of Materials	SHEET: 9 of 9 DATE: 8/17/2009 DRAWN BY: GRA/EAJ/RJT
			DWG. NAME: NYTCBP_R6 SCALE: None UNITS: in,[mm]	REV. BY: KAL/RKF

Figure 13. Bill of Materials, Test NYTCB-4





**Figure 14. Pinned Temporary Concrete Barrier, Test NYTCB-4**



**Figure 15. Connection Key, Test NYTCB-4**



**Figure 16. Anchored Barrier Sections, Test NYTCB-4**

## 6 FULL-SCALE CRASH TEST NO. NYTCB-4

### 6.1 Test No. NYTCB-4

The 5,172-lb (2,346-kg) pickup truck impacted the pinned temporary concrete barrier system at a speed of 62.3 mph (100.3 km/h) and at an angle of 24.3 degrees. A summary of the test results and sequential photographs are shown in Figure 17. Additional sequential photographs are shown in Figures 18 through 20. Documentary photographs of the crash test are shown in Figures 21 and 22.

### 6.2 Weather Conditions

Test No. NYTCB-4 was conducted on January 9, 2009 at approximately 1:15 pm. The weather conditions were reported as shown in Table 3.

**Table 3. Weather Conditions, Test No. NYTCB-4**

Temperature	36 ° F
Humidity	53 %
Wind Speed	24 mph
Wind Direction	350 ° from True North
Sky Conditions	Sunny
Visibility	9 Statute Miles
Pavement Surface	Dry
Previous 3-Day Precipitation	0 in.
Previous 7-Day Precipitation	0 in.

### 6.3 Test Description

Initial vehicle impact was to occur at the target location of 51 3/16 in. (1.3 m) upstream from the centerline of the joint between barrier nos. 4 and 5, as shown in Figure 23. Actual vehicle impact occurred at the targeted impact location. At 0.002 sec after impact, the left corner of the front bumper deflected inward. At 0.004 sec, the left headlight contacted the top of the barrier. At 0.008 sec, the top of barrier nos. 4 and 5 deflected away from impact. At 0.010 sec, the left-front quarter panel deformed. At 0.012 sec, the downstream end of barrier no. 4 deflected

backward. At 0.018 sec, the front grill deformed upward. At this same time, the left-front tire became airborne. At 0.028 sec, the front of the vehicle pitched upward and began redirecting. At this same time, the lower back side of barrier no. 5 experienced concrete spalling. At 0.032 sec, the top of the left-side door became ajar. At 0.038 sec, the upstream end of barrier no. 5 deflected backward. At this same time, the joint between barrier nos. 3 and 4 twisted. At 0.052 sec, the midpoint of barrier no. 4 deflected backward. At 0.068 sec, the left-front tire deflated. At 0.076 sec, the midpoint of the back side of barrier no. 5 encountered significant cracking. At 0.090 sec, the midpoint of barrier no. 5 deflected backward. At 0.104 sec, the right-front tire became airborne. At 0.226 sec, the downstream end of barrier no. 5 and the upstream end of barrier no. 6 deflected away from the vehicle. At this same time, the vehicle became parallel to the system with a velocity of approximately 48.4 mph (77.9 km/h). At 0.270 sec, the left-rear tire became airborne. At 0.276 sec, concrete spalling occurred at the back side of the upstream end of barrier no. 4, and the barrier continued to rotate backward about the upstream end. At 0.278 sec, the left-rear tire impacted the upstream end of barrier no. 5. At this same time, the front of the vehicle began to pitch downward. At 0.312 sec, the vehicle began to roll toward the right. At 0.314 sec, the entire vehicle became airborne as the right-rear tire became airborne. At 0.324 sec, the top portion of the joint between barrier nos. 4 and 5 separated. At 0.357 sec, the pitch angle of the vehicle was zero. At 0.378 sec, concrete spalling occurred at the lower-downstream end of the back side of barrier no. 3. At 0.496 sec, the vehicle exited the system at an angle of 7.6 degrees and a velocity of approximately 46 mph (74 km/h). At this same time, complete joint separation occurred between barrier nos. 4 and 5. At 0.510 sec, the downstream end of barrier no. 4 ceased movement. At 0.642 sec, the right-front tire contacted the ground. At 0.704 sec, the right corner of the front bumper contacted the ground. At 0.716 sec, the vehicle began to roll toward the left.

At 0.730 sec, the upstream end of barrier no. 5 ceased movement. At 0.826 sec, the rear of the vehicle began to pitch downward. At 0.848 sec, the left-front tire contacted the ground. At 0.922 sec, the right-front tire became airborne again. At 1.192 sec, the left-rear tire contacted the ground. At 1.314 the vehicle began to roll toward the right. At 1.356 sec, the left corner of the rear bumper contacted the ground. At 1.464 sec, the right-rear tire contacted the ground. At 1.528 sec, all four tires were in contact with the ground. The vehicle continued downstream before coming to rest 175 ft - 3 in. (53.4 m) downstream from impact and 6 ft - 5 in. (2.0 m) laterally away from the traffic-side face of the barrier. The trajectory and final position of the vehicle are shown in Figures 17 and 24.

#### **6.4 Barrier Damage**

Damage to the barrier was moderate, as shown in Figures 25 through 33. Barrier damage consisted of contact and gouge marks, concrete barrier cracking, and spalling, and joint failure. The length of the vehicle contact along the system was approximately 26.0 ft (7.93 m), which spanned from 72 3/16 in. (1.83 m) upstream from the downstream end of barrier no. 4 through the joint between barrier nos. 5 and 6.

Contact marks were visible on the front face of barrier nos. 4 and 5. Tire marks were found 72 3/16 in. (18.34 mm) upstream of the downstream end of barrier no. 4 and continued through the joint between barrier nos. 5 and 6.

Vertical cracking was found on the front and back sides of barrier no. 5 near the center of the barrier. Major cracking was also found on the back side of barrier no. 5 at 58 in. (1,473 mm). Major cracking was found on barrier no. 6 at 74 in. (1,880 mm) downstream from the joint between barrier nos. 5 and 6. Minor cracking occurred on the back side of barrier no. 6 at the upper-upstream end.

The lower-back corner on the downstream end of barrier no. 3 experienced concrete spalling. The lower-back corners on the upstream and downstream ends of barrier no. 4 experienced concrete spalling, as well as the lower-front corner on the downstream end of the barrier. The lower-back corners on the upstream and downstream ends of barrier no. 5 experienced concrete spalling. Concrete spalling also occurred on the upstream end of barrier no. 5 on both the upper- and lower-front corners. A large piece of concrete was removed from the upper-back side of the upstream end of barrier no. 5 near the connection key. The lower-back face of barrier no. 5 experienced major concrete spalling. Concrete spalling occurred on the lower-back corner of the upstream end of barrier no. 6.

The connection key between barrier nos. 4 and 5 fractured and bent toward the traffic side of the barrier. The connection key connecting barrier nos. 4 and 5 disengaged from barrier no. 4 but remained attached to barrier no. 5. Barrier no. 5 disengaged from the anchor rods. The deformed anchor rods remained embedded in the rigid concrete surface.

The permanent set of the barrier system is shown in Figure 25. The maximum lateral permanent set barrier deflection was 53½ in. (1,359 mm) at the upstream end of barrier no. 5, as measured in the field. The maximum lateral dynamic barrier deflection was 64 13/16 in. (1,646 mm) at the upstream end of barrier no. 5, as determined from high-speed digital video analysis. The working width of the system was found to be 95⅝ in. (2,427 mm).

## **6.5 Vehicle Damage**

The damage to the vehicle was moderate, as shown in Figures 34 through 37. Occupant compartment deformations to the left side and center of the floorboard were judged insufficient to cause serious injury to the vehicle occupants, as shown in Figure 37. Maximum longitudinal deflections of 5½ in. (140 mm) were located near the left-front region of the driver's-side floor

pan. Maximum lateral deflections of 2½ in. (64 mm) were located near the left-front corner of the left-side floor pan. Maximum vertical deflections of 6¾ in. (171 mm) were located near the left-front corner of the driver's-side floor pan. Complete occupant compartment deformations and the corresponding locations are provided in Appendix C.

Damage was concentrated on the left-front corner and left side of the vehicle. The left-front quarter panel deformed inward toward the engine compartment. The left-front wheel and brake line disengaged from the vehicle. The left-rear axle and brake line sheared, and the wheel assembly only remained attached to the vehicle by the emergency brake line. The left-front steel rim was deformed, and the tire bead broke. Scrapes and contact marks were found along the lower portion of the entire left side. The grill was detached and fractured. The hood shifted toward the left. The left headlight assembly and left corner of the front bumper were deformed inward. The left-front corner of the floorboard tore away at the side seam, as shown in Figure 37. The right side of the windshield was cracked. The left-front upper and lower control arm connections were fractured. The left-front vertical stabilizer bar link was bent, and the tie rod end disengaged. The left-rear rotor carrier brackets broke. The rear, roof, and right side of the vehicle as well as all other window glass remained undamaged.

## **6.6 Occupant Risk**

The occupant impact velocities (OIV) and 0.010-sec moving average occupant ridedown accelerations (ORA) are summarized in Table 4. The theoretical head impact velocities (THIV) and post-impact head decelerations (PHD) are also summarized in Table 4. It is noted that the OIV and ORA values were within the recommended limits provided in MASH. The results of the occupant risk, as determined from the accelerometer data, are summarized in Figure 17. The results from the accelerometer and rate transducer data are shown graphically in Appendix D.

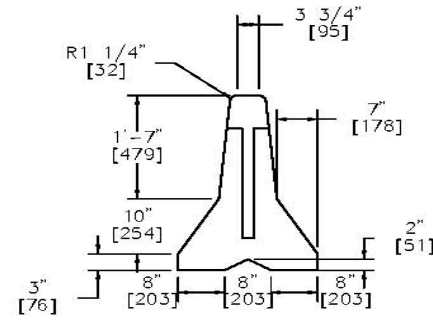
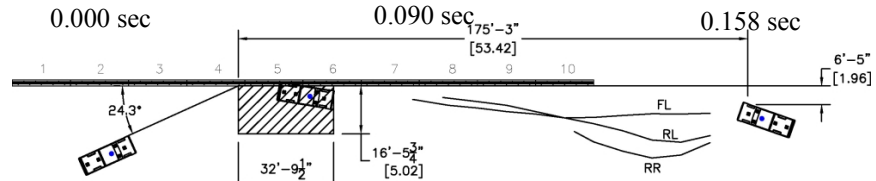

**Table 4. Summary of OIV, ORA, THIV, and PHD Values, Test NYTCB-4**

Occupant Risk Measures		Transducer	
		EDR-4	DTS
OIV ft/s (m/s)	Longitudinal	-17.09 (-5.21)	-15.53 (-4.73)
	Lateral	19.37 (5.90)	18.16 (5.53)
ORA g's	Longitudinal	-8.36	-8.25
	Lateral	7.65	7.53
THIV ft/s (m/s)		23.73 (7.23)	23.60 (7.19)
PHD g's		9.34	9.28

### 6.7 Discussion

The analysis of the test results for test no. NYTCB-4 showed that the pinned temporary concrete barrier system adequately contained and redirected the vehicle with controlled lateral displacements of the barrier system. There were no detached elements or fragments which showed the potential for penetrating the occupant compartment or presented undue hazard to other traffic. Deformation of, or intrusions into, the occupant compartment that could have caused serious injury did not occur. The test vehicle did not penetrate nor ride over the barrier and remained upright during and after the collision. Vehicle roll, pitch, and yaw angular displacements were noted, and they were deemed acceptable because they did not adversely influence occupant risk safety criteria nor cause rollover. After impact, the vehicle's trajectory revealed minimum intrusion into adjacent traffic lanes. In addition, the vehicle exited the barrier within the exit box. Therefore, test no. NYTCB-4 (test designation no. 3-11) was determined to be acceptable according to the TL-3 safety performance criteria found in MASH.



Side View

- Test Agency ..... MwRSF
- Test Number ..... NYTCB-4
- Date ..... 1/9/09
- MASH Test Designation ..... 3-11
- Appurtenance ..... Pinned Temporary Concrete Barrier
- Key Elements - Barrier
  - Description ..... New York TCB with Connection Keys
  - Length ..... 200 ft (60.96 m)
  - Base Width ..... 24 in. (610 mm)
  - Height ..... 32 in. (813 mm)
- Key Elements – Anchored Barrier Sections (1,3,5,7,9)
  - Pin Size ..... 1 in. (25 mm) diameter ASTM A36 rod
  - Pin Length ..... 15 1/2 in. (394 mm)
  - Number of Pins per Barrier ..... 4 on back side of 5 barrier segments
  - Embedment Depth ..... 5 in. (127 mm)
- Type of Support Surface ..... Rigid Concrete Pavement
- Test Vehicle
  - Type/Designation ..... 2270P
  - Make and Model ..... 2002 Dodge Ram 1500 Quad Cab 4x2
  - Curb ..... 5,225 lb (2,370 kg)
  - Test Inertial ..... 5,002 lb (2,269 kg)
  - Gross Static ..... 5,172 lb (2,346 kg)
- Impact Conditions
  - Speed ..... 62.3 mph (100.3 km/h)
  - Angle ..... 24.3 deg
  - Impact Location ..... 51 3/16 in. (1.3 m) upstream from centerline of joint 4-5
- Exit Conditions
  - Speed ..... 46 mph (74 km/h)
  - Angle ..... 7.6 deg
  - Exit Box Criterion ..... Pass
- Post Impact Trajectory
  - Vehicle Stability ..... Satisfactory
  - Stopping Distance ..... 175 ft - 3 in. (53.4 m) downstream  
6 ft - 5 in. (2.0 m) laterally away
- Occupant Impact Velocity (EDR-4)
  - Longitudinal ..... -17.09 ft/s (-5.21 m/s)  
< 40 ft/s (12.2 m/s)
  - Lateral ..... 19.37 ft/s (5.90 m/s)  
< 40 ft/s (12.2 m/s)

- Occupant Ridedown Acceleration (EDR-4)
  - Longitudinal ..... -8.36 g's < 20.49 g's
  - Lateral ..... 7.65 g's < 20.49 g's
- Occupant Impact Velocity (DTS)
  - Longitudinal ..... -15.53 ft/s (-4.73 m/s) < 40 ft/s (12.2 m/s)
  - Lateral ..... 18.16 ft/s (5.53 m/s) < 40 ft/s (12.2 m/s)
- Occupant Ridedown Acceleration (DTS)
  - Longitudinal ..... -8.25 g's < 20.49 g's
  - Lateral ..... 7.53 g's < 20.49 g's
- THIV (EDR-4) (not required) ..... 23.73 ft/s (7.23 m/s)
- THIV (DTS) (not required) ..... 23.60 ft/s (7.19 m/s)
- PHD (EDR-4) (not required) ..... 9.34 g's
- PHD (DTS) (not required) ..... 9.28 g's
- Vehicle Damage ..... Moderate
  - VDS<sup>(14)</sup> ..... 11-LFQ-4
  - CDC<sup>(15)</sup> ..... 11-LYEN3
  - Maximum Deformation ..... 6 3/4 in. (171 mm) left-front corner
- Test Article Damage ..... Moderate
- Test Article Deflections
  - Permanent Set ..... 53 1/2 in. (1,359 mm)
  - Dynamic ..... 64 13/16 in. (1,646 mm)
  - Working Width ..... 95 5/8 in. (2,427 mm)
- Angular Displacements (EDR-4)
  - Roll ..... -30.4 deg
  - Pitch ..... -23.8 deg
  - Yaw ..... -144.1 deg
- Angular Displacements (DTS)
  - Roll ..... -29.8 deg
  - Pitch ..... -23.8 deg
  - Yaw ..... -143.6 deg

Figure 17. Summary of Test Results and Sequential Photographs, Test NYTCB-4



0.000 sec



0.460 sec



0.068 sec



0.642 sec



0.144 sec



0.826 sec



0.226 sec



1.192 sec



0.314 sec



1.528 sec

**Figure 18. Additional Sequential Photographs, Test NYTCB-4**



0.000 sec



0.276 sec



0.068 sec



0.324 sec



0.076 sec



0.378 sec



0.136 sec



0.460 sec



0.204 sec



0.534 sec

**Figure 19. Additional Sequential Photographs, Test NYTCB-4**



0.000 sec



0.460 sec



0.092 sec



0.516 sec



0.218 sec



0.608 sec



0.272 sec



0.914 sec



0.388 sec



1.124 sec

**Figure 20. Additional Sequential Photographs, Test NYTCB-4**

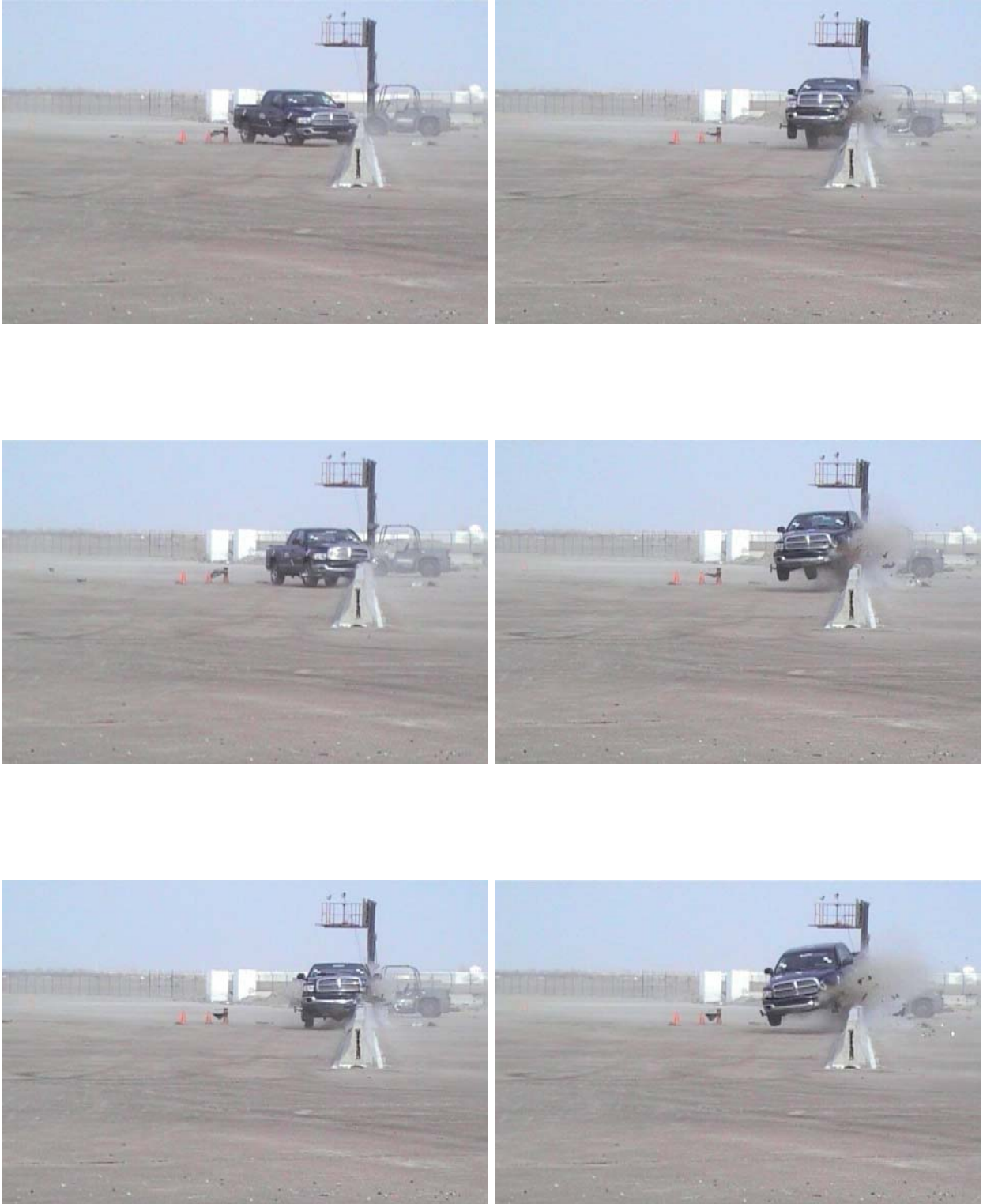

**Figure 21. Documentary Photographs, Test NYTCB-4**



**Figure 22. Documentary Photographs, Test NYTCB-4**



**Figure 23. Impact Location, Test NYTCB-4**





**Figure 24. Vehicle Final Position and Trajectory Marks, Test NYTCB-4**



**Figure 25. System Damage, Test NYTCB-4**



Figure 26. Barrier No. 4 Damage, Test NYTCB-4



**Figure 27. Barrier No. 5 Damage, Test NYTCB-4**



Upstream



Mid-Upstream



Mid-Downstream

**Figure 28. Barrier No. 5 Anchor Rod Damage, Test NYTCB-4**

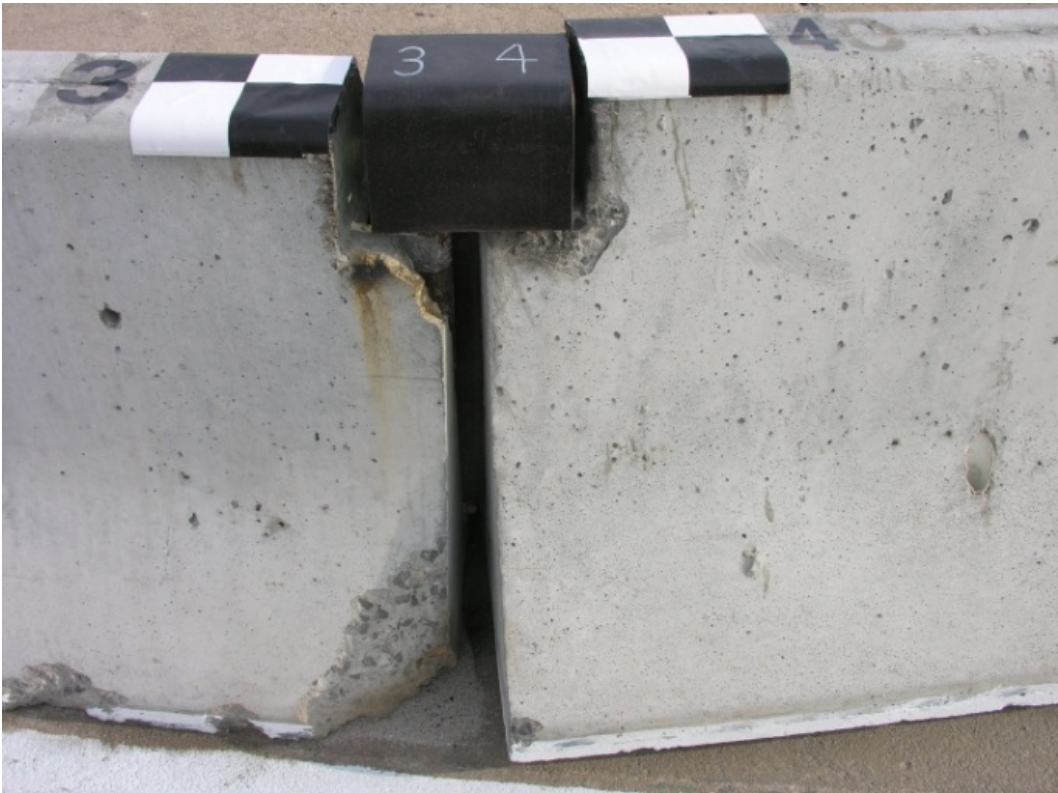

**Figure 29. Joint 3-4 Connection Damage, Test NYTCB-4**



**Figure 30. Joint 4-5 Connection Damage, Test NYTCB-4**



**Figure 31. Joint 4-5 Connection Damage (Cont'd), Test NYTCB-4**





**Figure 32. Joint 5-6 Connection Damage, Test NYTCB-4**



**Figure 33. Joint 6-7 Connection Damage, Test NYTCB-4**



Figure 34. Vehicle Damage, Test NYTCB-4



Figure 35. Vehicle Damage, Test NYTCB-4



**Figure 36. Undercarriage Damage, Test NYTCB-4**



**Figure 37. Occupant Compartment Deformation, Test NYTCB-4**

## 7 SUMMARY, CONCLUSIONS, AND RECOMMENDATIONS

The major goal of this study was to investigate the potential for reducing barrier deflections through the use of vertical steel pins placed through the back-side toe of alternating NYSDOT New Jersey shape TCB sections. A longitudinal barrier system was constructed with ten, 20-ft (6.10-m) long, temporary concrete barrier sections utilizing a connection key between the barrier sections. Five free-standing and five pinned barrier sections formed the test installation. Barrier section nos. 1, 3, 5, 7, and 9 were pinned to the concrete surface with four 1-in. (25-mm) diameter by 15½-in. (394-mm) long steel rods placed through the back-side toe of the noted barrier sections and inserted into drilled holes within the rigid concrete surface.

One full-scale vehicle crash test was conducted, evaluated, and reported according to the TL-3 safety performance criteria found in the MASH guidelines. A summary of the safety performance evaluation of the test is provided in Table 5. Test no. NYTCB-4 (test designation 3-11) consisted of a 5,172-lb (2,346-kg) pickup truck impacting the barrier system at a speed of 62.3 mph (100.3 km/h) and at an angle of 24.3 degrees, resulting in an impact severity of 113.73 kip-ft (154.19 kJ). The target impact location for this test was 51 3/16 in. (1.3 m) upstream from the centerline of the joint between barrier nos. 4 and 5. The maximum permanent set and dynamic deflections were 53½ in. (1,359 mm) and 64 13/16 in. (1,646 mm), respectively. Following an evaluation of the test results, the alternating-pinned, New Jersey-shape, temporary concrete barrier system was found to meet the MASH TL-3 safety requirements for the 2270P pickup truck.

During test no. NYTCB-4, the joint between barrier nos. 4 and 5 completely separated due to the vehicle's tail slap against the barrier, thus resulting in additional dynamic deflection of the barrier system. The joint separation occurred at approximately the same time that the vehicle

had exited the barrier system. The vehicle was contained and safely redirected. Although complete joint separation had occurred and generally is deemed undesirable, it is the researchers opinion that the alternating-pinned, New Jersey-shape, TCB system met the TL-3 safety performance criteria specified in the MASH guidelines for the 2270P impact condition. It should also be noted that joint separation has been observed in prior pickup truck crash tests into other crash-tested, FHWA-accepted, temporary concrete barrier systems (16-17).

**Table 5. Summary of MASH Safety Performance Evaluation Results**

Evaluation Factors	Evaluation Criteria	Test No. NYTCB-4
Structural Adequacy	A. Test article should contain and redirect the vehicle; the vehicle should not penetrate, underride, or override the installation although a controlled lateral deflection of the test article is acceptable.	S
Occupant Risk	D. Detached elements, fragments or other debris from the test article should not penetrate or show potential for penetrating the occupant compartment, or present an undue hazard to other traffic, pedestrians, or personnel in a work zone. Deformations of, or intrusions into, the occupant compartment should not exceed limits set forth in Section 5.3 of Appendix E of MASH.	S
	F. The vehicle should remain upright during and after collision. The maximum roll and pitch angles are not to exceed 75 degrees.	S
	H. Longitudinal and lateral occupant impact velocities should fall below the preferred value of 30 ft/s (9.1 m/s), or at least below the maximum allowable value of 40 ft/s (12.2 m/s).	S
	I. Longitudinal and lateral occupant ridedown accelerations should fall below the preferred value of 15.0 g's, or at least below the maximum allowable value of 20.49 g's.	S

S - Satisfactory  
U - Unsatisfactory  
NA - Not Available



## 8 REFERENCES

1. Mak, K.K., Bligh, R.P., Menges, W.L., Schoeneman, S.K., *NCHRP Report 350 Test 3-11 of the New York DOT Portable Concrete Barrier with I-Beam Connection*, Research Report No. 473220-7, Texas Transportation Institute, The Texas A&M University System, College Station, TX, February 1999.
2. Bligh, R.P., Menges, W.L., Sanders, S.K., *NCHRP Report 350 Test 3-11 of the New York DOT Portable Concrete Barrier with I-Beam Connection (Retest)*, Research Report No. 473220-14, Texas Transportation Institute, The Texas A&M University System, College Station, TX, July 2001.
3. Stolle, C.J., Polivka, K.A., Faller, R.K., Sicking, D.L., Bielenberg, R.W., Reid, J.D., Rohde, J.R., Allison, E.M., and Terpsma, R.J., *Evaluation of Box Beam Stiffening of Unanchored Temporary Concrete Barriers*, Transportation Research Report No. TRP-03-202-08, Midwest Roadside Safety Facility, University of Nebraska-Lincoln, March 14, 2008.
4. Ross, H.E., Sicking, D.L., Zimmer, R.A., and Michie, J.D., *Recommended Procedures for the Safety Performance Evaluation of Highway Features*, National Cooperative Highway Research Program (NCHRP) Report No. 350, Transportation Research Board, Washington, D.C., 1993.
5. Sicking, D.L., Mak, K.K., Rohde, J.R., and Reid, J.D., *Manual for Assessing Safety Hardware – Draft Report*, National Cooperative Highway Research Program (NCHRP), Project 22-14(2) Panel, 2008.
6. Buth, C.E., Hirsch, T.J., and McDevitt, C.F., *Performance Level 2 Bridge Railings*, Transportation Research Record No. 1258, Transportation Research Board, National Research Council, Washington, D.C., 1990.
7. *Guide Specifications for Bridge Railings*, American Association of State Highway and Transportation Officials (AASHTO), Washington, D.C., 1989.
8. Bronstad, M.E., Calcote, L.R., and Kimball, C.E., Jr., *Concrete Median Barrier Research-Vol.2 Research Report*, Report No. FHWA-RD-77-4, Submitted to the Office of Research and Development, Federal Highway Administration, Performed by Southwest Research Institute, San Antonio, TX, March 1976.
9. Buth, C.E., Campise, W.L., Griffin III, L.I., Love, M.L., and Sicking, D.L., *Performance Limits of Longitudinal Barrier Systems-Volume I: Summary Report*, FHWA/RD-86/153, Final Report to the Federal Highway Administration, Office of Safety and Traffic Operations R&D, Performed by Texas Transportation Institute, Texas A&M University, College Station, TX, May 1986.

10. Polivka, K.A., Faller, R.K., Sicking, D.L., Rohde, J.R., Bielenberg, B.W., Reid, J.D., and Coon, B.A. *Performance Evaluation of the Permanent New Jersey Safety Shape Barrier – Update to NCHRP 350 Test No. 3-10 (2214NJ-1)*, Final Report to the Transportation Research Board, National Research Council, National Cooperative Highway Research Program (NCHRP), NCHRP Project No. 22-14(2), Transportation Research Report No. TRP-03-177-06, Midwest Roadside Safety Facility, University of Nebraska-Lincoln, October 13, 2006.
11. Fortuniewicz, J.S., Bryden, J.E., and Phillips, R.G., *Crash Tests of Portable Concrete Median Barrier for Maintenance Zones*, Report No. FHWA/NY/RR-82/102, Final Report to the Office of Research, Development, and Technology, Federal Highway Administration, Performed by the Engineering Research and Development Bureau, New York State Department of Transportation, December 1982.
12. Hinch, J., Yang, T-L, and Owings, R., *Guidance Systems for Vehicle Testing*, ENSCO, Inc., Springfield, VA 1986.
13. Center of Gravity Test Code - SAE J874 March 1981, SAE Handbook Vol. 4, Society of Automotive Engineers, Inc., Warrendale, Pennsylvania, 1986.
14. *Vehicle Damage Scale for Traffic Investigators*, Second Edition, Technical Bulletin No. 1, Traffic Accident Data (TAD) Project, National Safety Council, Chicago, Illinois, 1971.
15. *Collision Deformation Classification – Recommended Practice J224 March 1980*, Handbook Volume 4, Society of Automotive Engineers (SAE), Warrendale, Pennsylvania, 1985.
16. Wright, F.G., Federal Highway Administration (FHWA), *NCHRP 350 Approval Letter No. HSA-B-67 for the Georgia DOT Temporary Concrete Barrier*, To C. Eugene Buth, Texas Transportation Institute, Texas A&M University, College Station, Texas, March 30, 2000.
17. Wright, F.G., Federal Highway Administration (FHWA), *NCHRP 350 Approval Letter No. HSA-B-79 for the Pennsylvania DOT Temporary Concrete Barrier*, To Gary L. Hoffman, Pennsylvania Department of Transportation, Harrisburg, Pennsylvania, December 18, 2000.

## **9 APPENDICES**

## **APPENDIX A. Vehicle Center of Gravity Determination**

NYTCB-4		Vehicle: 2002 Dodge Ram 1500QC				
Vehicle CG Determination						
VEHICLE	Equipment	Weight	Long CG	Vert CG	HOR M	Vert M
+	Unbalasted Truck	5224	62.25	28.5	325194	148884
+	Brake receivers/wires	5	116	51	580	255
+	Brake Frame	5	34	31	170	155
+	Brake Cylinder	22	74	29	1628	638
+	Strobe Battery	6	76	32	456	192
+	Hub	27	0	15	0	405
+	CG Plate (EDRs)	8	54	32	432	256
-	Battery	-47	-7	45	329	-2115
-	Oil	-10	8	19	-80	-190
-	Interior	-76	44	24	-3344	-1824
-	Fuel	-161	111	20	-17871	-3220
-	Coolant	-18	-18	35	324	-630
-	Washer fluid	-8	-15	35	120	-280
BALLAST	Water	10	111	20	1110	200
	Misc. (DTS equip)	15	74	27	1110	405
	Misc.		0	0	0	0
TOTAL WEIGHT		5002			310158	143131
					62.0068	28.61475

wheel base 140.25

NCHRP 350 Targets		CURRENT	Difference
Test Inertial Weight	5000	5002	2.0
Long CG	62	62.01	0.00680
Vert CG	28	28.61	0.61475

Note, Long. CG is measured from front axle of test vehicle

Curb Weight		
	Left	Right
Front	1459	1444
Rear	1170	1151
FRONT	2903	
REAR	2321	
TOTAL	5224	

Actual test inertial weight		
	Left	Right
Front	1383	1400
Rear	1068	1151
FRONT	2783	
REAR	2219	
TOTAL	5002	

Figure A-1. Vehicle Mass Distribution, Test NYTCB-4

## **APPENDIX B. Material Specifications**

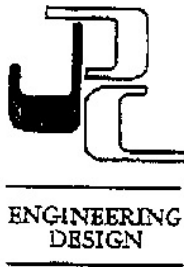

# JERSEY PRECAST CORP.

1000 Somerset St., New Brunswick, NJ 08901  
P.O. Box 7443, North Brunswick, NJ 08902  
Phone: 732-249-8973 • Fax: 732-249-9720  
E-Mail: [jzprecast@aol.com](mailto:jzprecast@aol.com)  
[www.jerseyprecast.com](http://www.jerseyprecast.com)



**Date:** June 13, 2007

**Company:** Midwest Roadside Safety Facility-  
University of Nebraska

**Proposal #** 07-198

**Attention:** Gregg Averill

**Location:** Lincoln, Nebraska

**Phone:** 402-472-2022

**Reference:**

**Fax:** 402-709-2943

[gaverill@bigred.unl.edu](mailto:gaverill@bigred.unl.edu)

**JERSEY PRECAST CORPORATION PROPOSES TO MANUFACTURE AND DELIVER THE FOLLOWING:**

Approximate Lft: 240

12 pcs Precast Temporary Construction Barrier 24" x 32"x 20' @ \$ 31.00 /Lft  
M619-3R1 with pin holes  
4000 psi Grey concrete, uncoated reinforcing, with uncoated steel interlocks

PICKED-UP - 400 LBS/LFT

Excludes: anchor bolts, washers, reflectors, delineators, stripes, fence post sleeves, and layout drawings

**Terms:**  
Quote valid for 30 days  
Payment at time of delivery or pick-up

Plus applicable taxes

Approved by: \_\_\_\_\_  
Purchase Order #:  
**Please sign and return by fax**

Yours truly  
Paul Dentel

Figure B-1. Temporary Concrete Barrier Mill Specifications, Test NYTCB-4

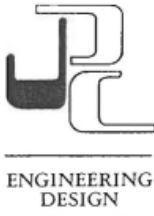

# JERSEY PRECAST CORP.

1000 Somerset St., New Brunswick, NJ 08901  
P.O. Box 7443, North Brunswick, NJ 08902  
Phone: 732-249-8973 • Fax: 732-249-9720  
E-Mail: jrjzprecast@aol.com  
www.jerseyprecast.com



July 5, 2007  
Job #07-084

## CERTIFICATION OF COMPLIANCE NYS DEPARTMENT OF TRANSPORTATION

- 1. Project: Midwest Roadside Safety-MWRSF
- 2. Contractor: University of Nebraska Lincoln  
401 Canfield Admin. Bldg.  
P.O. Box 880439  
Lincoln, NE. 68588-0439
- 3. Material Supplied: Precast Concrete Construction Barrier
- 4. Quantity of Material Supplied: 240 Lft. Typical Barrier
- 5. Means of Identification: Barrier Elements are dated per date of fabrication.
- 6. Date & Method of Shipment: 7/5/07, on Flat Bed Trailer.
- 7. Material Found to Conform: The 240 Lft. of Precast Concrete Temporary Construction Barrier as supplied to the job site has been manufactured using tested and approved materials and meets or exceeds applicable ASTM standards and NY Dept. of Transportation Plan, Specifications and requirements.

8. Signature of Authorization For Jersey Precast Corp:   
Khwaja H. Abbas, General Manager

9. Notary Public Attestment: State of New Jersey  
County of Middlesex  
Sworn and Subscribed Before Me  
The 5<sup>th</sup> Day of July, 2007



**A DISADVANTAGED/MINORITY BUSINESS ENTERPRISE (DBE/MBE)  
CERTIFIED AGENCY APPROVED PRECAST CONCRETE CONSTRUCTOR**  
N.J. DOT • N.Y./N.J. PORT AUTH. • N.Y. DOT • PA. DOT • N.J.T.A. • GSA • N.Y.T.W. • D.I.R.P.A.

Figure B-2. Temporary Concrete Barrier Certificate of Conformity, Test NYTCB-4



Rivers-Metal Products, Inc. 3100 North-38th Street Lincoln NE 68504-1998		Telephone: (402) 466-2329 Main Office Fax: (402) 466-9140 Rotational Molds Division Fax: (402) 466-0937 Internet E-mail: rmp@riversmetal.com
--	---	---

Invoice: 634626	Invoice	Page: 1 of 1 Date: 12/12/2008
-----------------	---------	----------------------------------

<b>Bill To:</b> Accounts Payable University of Nebraska - Lincoln 401 Administration Building Lincoln NE 68588-0439	<b>Ship To:</b> University of Nebraska - Lincoln 401 Administration Building Lincoln NE 68588-0439 <div style="text-align: center; font-weight: bold; font-size: 1.2em;">SHIPPED</div> <div style="text-align: center;">DEC 12 2008</div> <div style="text-align: center; font-weight: bold;">RIVERS METAL PROD.</div>
---	--

PO Number: CREDIT CARD	Terms: Net 30 Days	F.O.B: RMP
Sales Rep: Paul Mara	Ordered: 12/11/2008	Ship Via: Pick-up
Packing Slip:	Sales Tax ID: 0305-256-536	Ship Date: 12/12/2008

Line	Quantity	Part Number/Description	Revision	Unit Price	Ext Price	
1	0.67EA	HR1 1" Hot Roll Round 20' 2EA X 81"		101.12000 EA	\$67.75	
2	2.00EA	CUTTING Cutting		5.00000 EA	\$10.00	
<b>- Taxes -</b>				<b>Taxable Amount</b>	<b>Percent</b>	<b>Amount</b>
				Government	\$77.75	
<b>Payment Schedule</b>				<b>Due Date</b>	<b>Amount</b>	
				1/11/2009	\$77.75	

<b>Please remit this amount:</b>	<b>\$77.75</b>
----------------------------------	----------------

*Ron Faller*

Figure B-3. Steel Pin Specifications, Test NYTCB-4

## **APPENDIX C. Vehicle Deformation Data**

VEHICLE PRE/POST CRUSH INFO  
Set-1

TEST: NYTCB-4  
VEHICLE: 2002 Dodge Ram

POINT	X	Y	Z	X'	Y'	Z'	DEL X	DEL Y	DEL Z
1	30.75	-26.25	0	26.5	-25	5	-4.25	1.25	5.25
2	33.75	-22	-0.5	29	-22	5.25	-4.75	0	6
3	33.75	-15.25	-1	31	-16.25	3	-2.75	-1	4.25
4	29.75	-9	0.75	29.75	-9.25	0.25	0	-0.25	-0.25
5	27.75	-26.5	-3.5	22.25	-24	2.75	-5.5	2.5	6.5
6	30	-21.5	-4.75	25.25	-19	1	-4.75	2.5	6
7	30.5	-15	-5	28.25	-14	-3	-2.25	1	2.25
8	27.75	-7.5	-3.5	27.75	-6.75	-3.75	0	0.75	0
9	23.5	-27.25	-7.5	18.25	-26	-2	-5.25	1.25	5.75
10	23.5	-21	-7.75	20.25	-19	-5.25	-3.25	2	2.75
11	23.5	-14.75	-8	22.75	-12.5	-8.25	-0.75	2.25	0
12	21	-6.5	-2.75	21	-6.25	-3.25	0	0.25	-0.25
13	16.75	-26.75	-8.75	16.25	-24.5	-8.5	-0.5	2.25	0.5
14	16.75	-20.25	-9	16.25	-19	-9	-0.5	1.25	0.25
15	16.75	-14.5	-9.25	16.5	-14.25	-9.5	-0.25	0.25	0
16	14.5	-7.5	-6	14.75	-7	-6.25	0.25	0.5	0
17	13.75	-1.75	-2.5	13.75	-1.75	-2.5	0	0	0.25
18	11	-26.25	-8.25	11.25	-25	-9	0.25	1.25	-0.5
19	11	-20.5	-8.5	11	-19	-9	0	1.5	-0.25
20	11	-14	-8.75	11	-13.25	-9	0	0.75	0
21	9.5	-8.25	-6.5	9.75	-7	-7.25	0.25	1.25	-0.5
22	10.75	-2.5	-2.5	10.75	-2.75	-2.75	0	-0.25	0
23	1	-26.5	-4	1	-26.5	-4	0	0	0
24	0.75	-22	-4.25	0.75	-22	-4.5	0	0	-0.25
25	0.75	-17	-4.5	0.75	-17.25	-4.5	0	-0.25	0
26	0.75	-12.5	-4.5	0.75	-12	-4.75	0	0.5	-0.25
27	1.25	-7.5	-2.75	1.25	-7	-2.75	0	0.5	0
28	1	-1.5	-2.25	1	-1.25	-2.25	0	0.25	0
29							0	0	0
30									

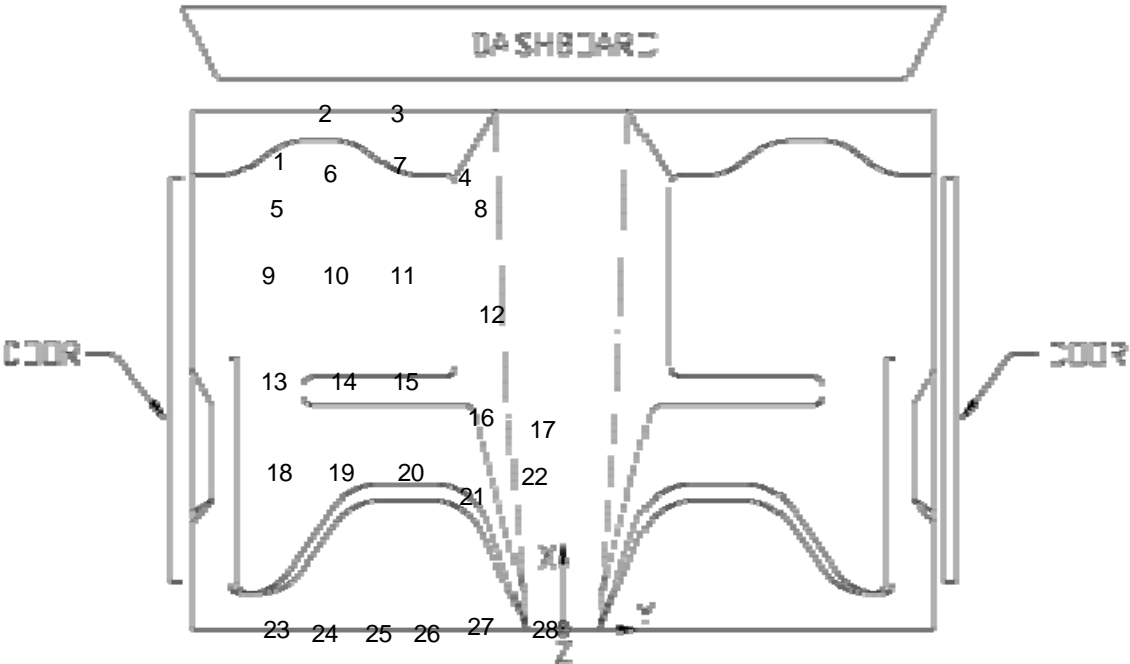

Figure C-1. Occupant Compartment Deformation Data – Set 1, Test NYTCB-4

VEHICLE PRE/POST CRUSH INFO  
Set-2

TEST: NYTCB-4  
VEHICLE: 2002 Dodge Ram

POINT	X	Y	Z	X'	Y'	Z'	DEL X	DEL Y	DEL Z
1	53.75	-31.25	-1	49.5	-30	5	-4.25	1.25	6
2	56.75	-27	-1.25	52	-27	5	-4.75	0	6.25
3	56.75	-20.25	-1.75	54	-21.25	2.5	-2.75	-1	4.25
4	52.75	-14	0	52.75	-14.25	0	0	-0.25	0
5	50.75	-31.5	-4	45.25	-29	2.75	-5.5	2.5	6.75
6	53	-26.5	-5.5	48.25	-24	1	-4.75	2.5	6.5
7	53.5	-20	-5.75	51.25	-19	-3	-2.25	1	2.75
8	50.75	-12.5	-4	50.75	-11.75	-3.75	0	0.75	0.25
9	46.5	-32.25	-7.75	41.25	-31	-2.75	-5.25	1.25	5
10	46.5	-26	-8.5	43.25	-24	-5.75	-3.25	2	2.75
11	46.5	-19.75	-8.5	45.75	-17.5	-8.5	-0.75	2.25	0
12	44	-11.5	-4	44	-11.25	-3.5	0	0.25	0.5
13	39.75	-31.75	-9.5	39.25	-29.5	-8.75	-0.5	2.25	0.75
14	39.75	-25.25	-9.75	39.25	-24	-9.25	-0.5	1.25	0.5
15	39.75	-19.5	-10	39.5	-19.25	-9.75	-0.25	0.25	0.25
16	37.5	-12.5	-6.75	37.75	-12	-6.5	0.25	0.5	0.25
17	36.75	-6.75	-3.25	36.75	-6.75	-3	0	0	0.25
18	34	-31.25	-9	34.25	-30	-9.25	0.25	1.25	-0.25
19	34	-25.5	-9	34	-24	-9.25	0	1.5	-0.25
20	34	-19	-9.5	34	-18.25	-9.5	0	0.75	0
21	32.5	-13.25	-7.5	32.75	-12	-7.5	0.25	1.25	0
22	33.75	-7.5	-3.5	33.75	-7.75	-3.25	0	-0.25	0.25
23	24	-31.5	-4.5	24	-31.5	-4.5	0	0	0
24	23.75	-27	-4.75	23.75	-27	-4.75	0	0	0
25	23.75	-22	-5	23.75	-22.25	-5	0	-0.25	0
26	23.75	-17.5	-5.25	23.75	-17	-5.25	0	0.5	0
27	24.25	-12.5	-3.5	24.25	-12	-3	0	0.5	0.5
28	24	-6.5	-3.25	24	-6.25	-3	0	0.25	0.25
29							0	0	0
30									

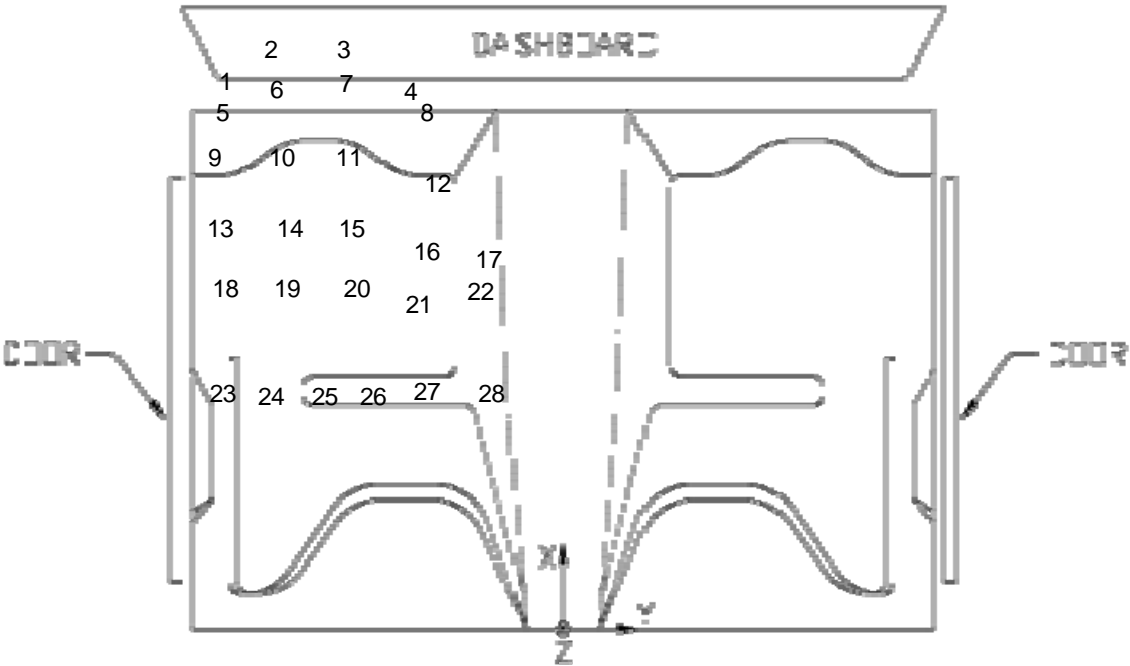

Figure C-2. Occupant Compartment Deformation Data – Set 2, Test NYTCB-4

**Occupant Compartment Deformation Index (OCDI)**

Test No. NYTCB-4  
Vehicle Type: 2002 Dodge Ram

OCDI = XXABCDEFGHI

- XX = location of occupant compartment deformation
- A = distance between the dashboard and a reference point at the rear of the occupant compartment, such as the top of the rear seat or the rear of the cab on a pickup
- B = distance between the roof and the floor panel
- C = distance between a reference point at the rear of the occupant compartment and the motor panel
- D = distance between the lower dashboard and the floor panel
- E = interior width
- F = distance between the lower edge of right window and the upper edge of left window
- G = distance between the lower edge of left window and the upper edge of right window
- H = distance between bottom front corner and top rear corner of the passenger side window
- I = distance between bottom front corner and top rear corner of the driver side window

**Severity Indices**

- 0 - if the reduction is less than 3%
- 1 - if the reduction is greater than 3% and less than or equal to 10 %
- 2 - if the reduction is greater than 10% and less than or equal to 20 %
- 3 - if the reduction is greater than 20% and less than or equal to 30 %
- 4 - if the reduction is greater than 30% and less than or equal to 40 %

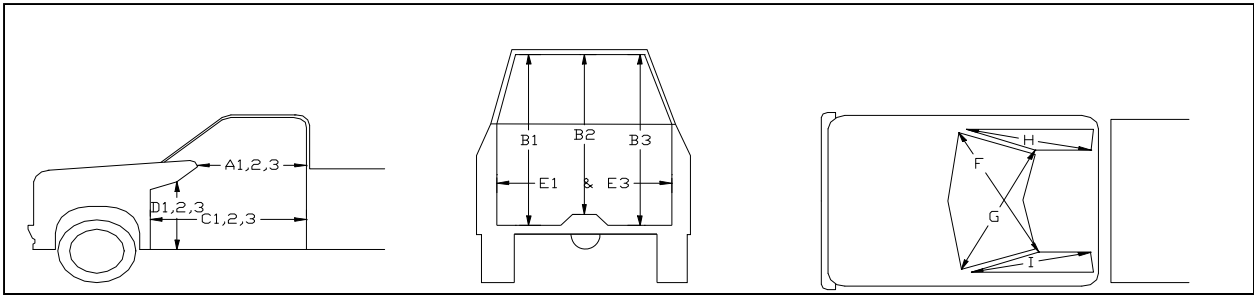

where,  
1 = Passenger Side  
2 = Middle  
3 = Driver Side

**Location:**

Measurement	Pre-Test (in.)	Post-Test (in.)	Change (in.)	% Difference	Severity Index
A1	57.25	57.25	0.00	0.00	0
A2	50.25	50.25	0.00	0.00	0
A3	58.50	58.50	0.00	0.00	0
B1	47.50	48.25	0.75	1.58	0
B2	42.25	42.25	0.00	0.00	0
B3	47.50	47.50	0.00	0.00	0
C1	70.75	68.25	-2.50	-3.53	1
C2	46.75	46.75	0.00	0.00	0
C3	68.75	68.75	0.00	0.00	0
D1	22.75	23.25	0.50	2.20	0
D2	13.50	13.50	0.00	0.00	0
D3	22.25	22.50	0.25	1.12	0
E1	65.25	65.50	0.25	0.38	0
E3	64.75	64.75	0.00	0.00	0
F	60.00	60.00	0.00	0.00	0
G	60.00	60.00	0.00	0.00	0
H	41.00	41.00	0.00	0.00	0
I	41.25	41.25	0.00	0.00	0

Note: Maximum severity index for each variable (A-I) is used for determination of final OCDI value

Final OCDI: XX A B C D E F G H I  
LF 0 0 1 0 0 0 0 0 0

**Figure C-3. Occupant Compartment Deformation Index (OCDI), Test NYTCB-4**

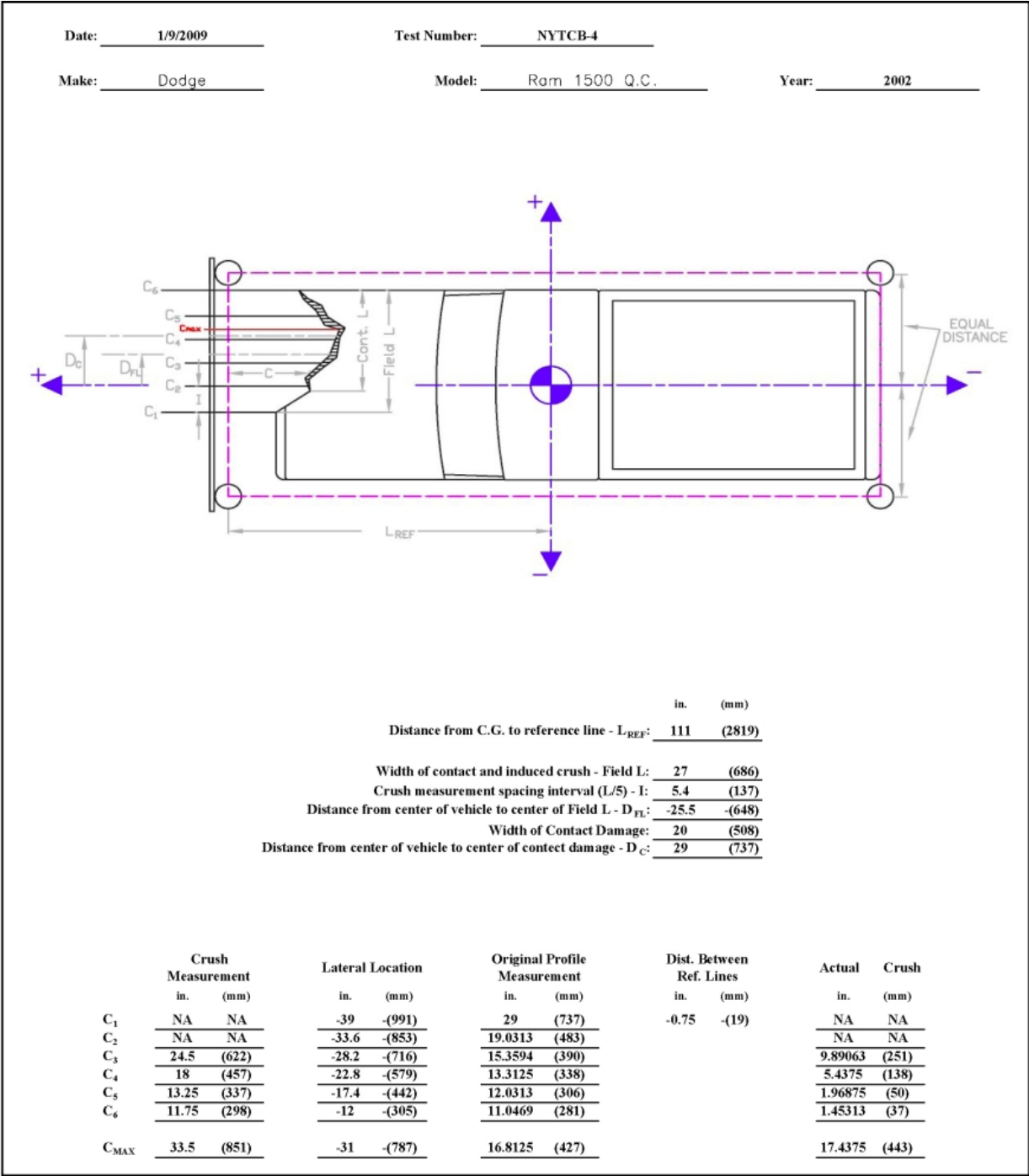

Figure C-4. External Vehicle Crush (NASS) - Front, Test NYTCB-4

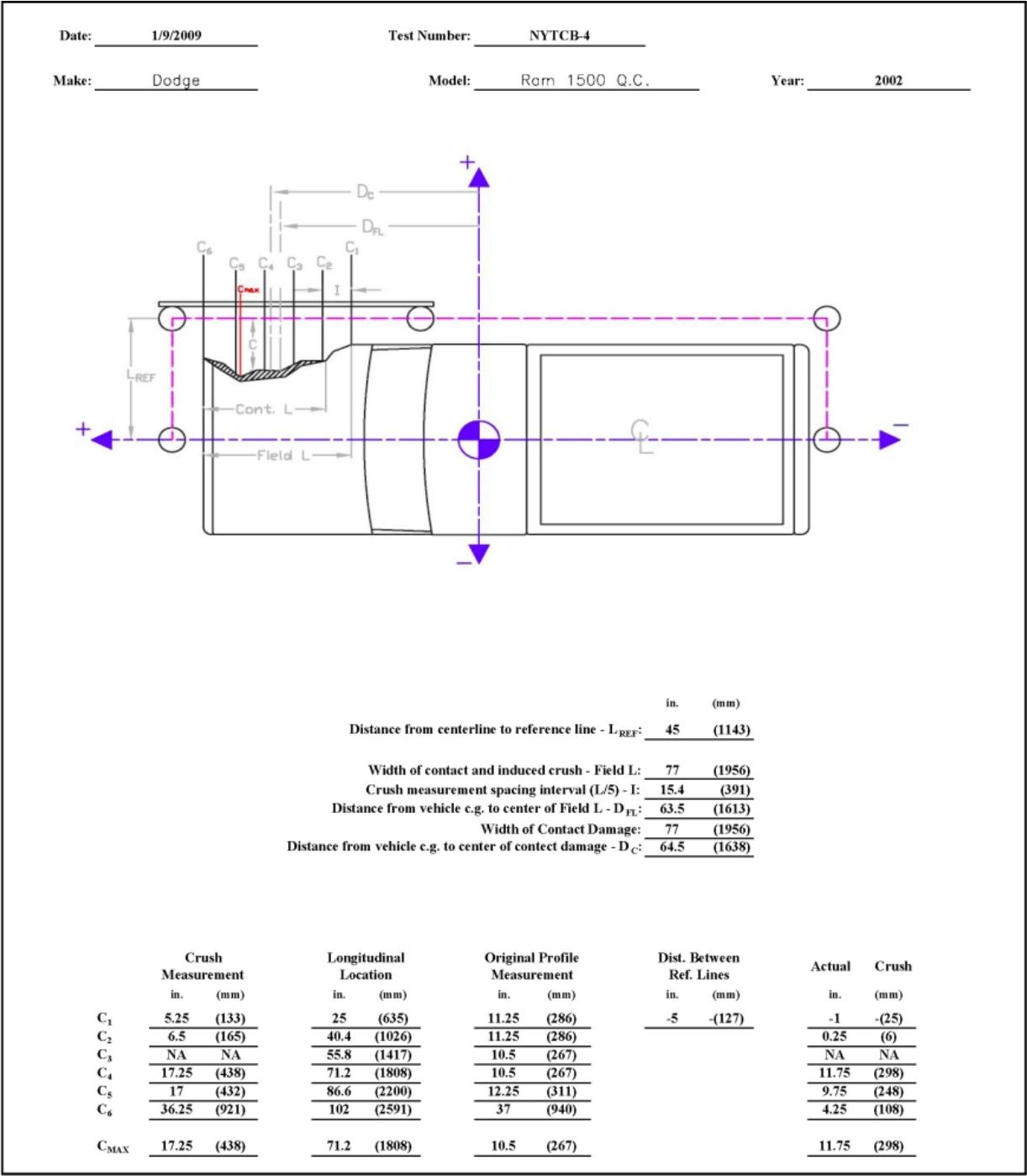

Figure C-5. External Vehicle Crush (NASS) - Side, Test NYTCB-4

## **APPENDIX D. Accelerometer and Rate Transducer Data Analysis**



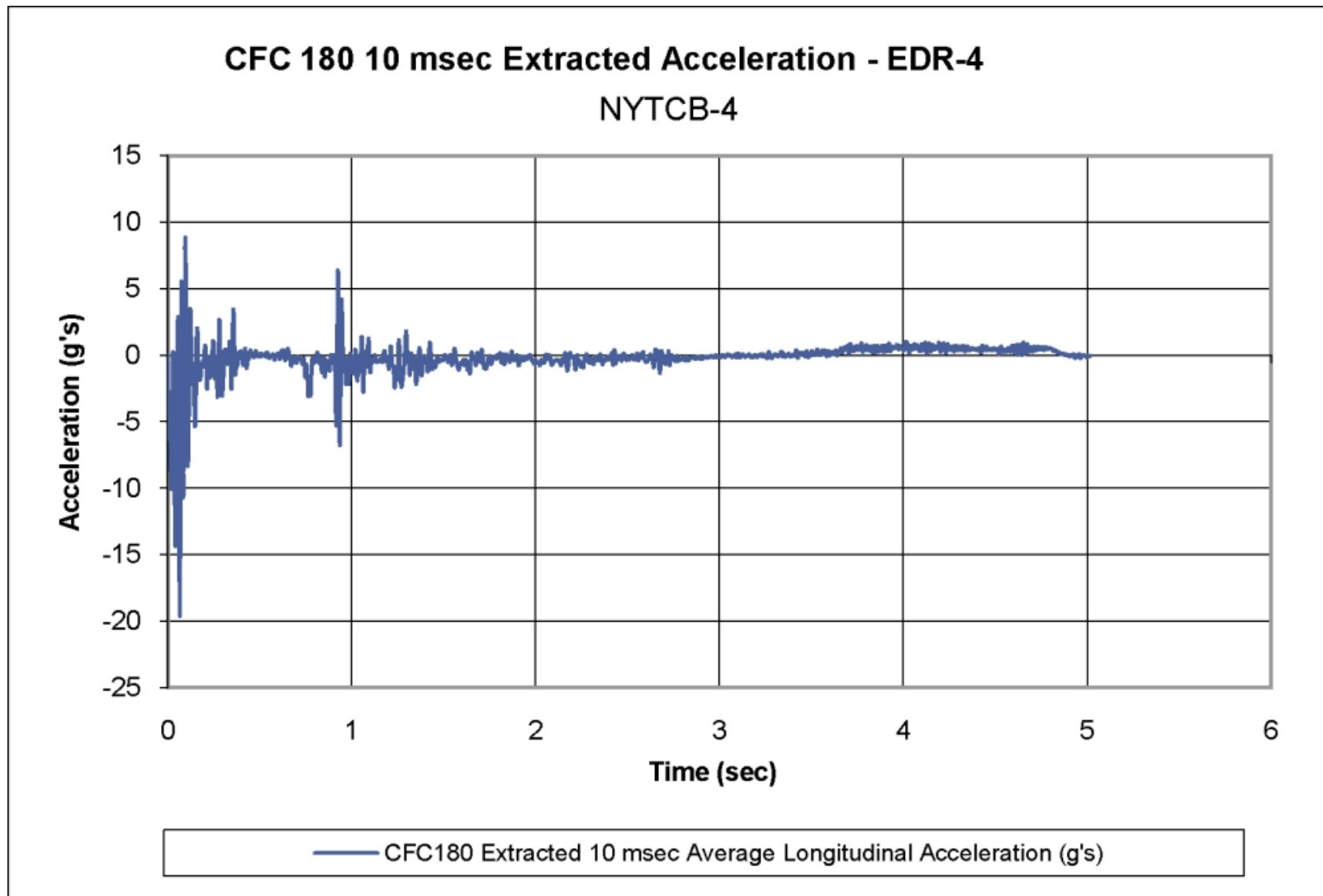

Figure D-1. Graph of 10 ms Average Longitudinal Deceleration (EDR-4), Test NYTCB-4

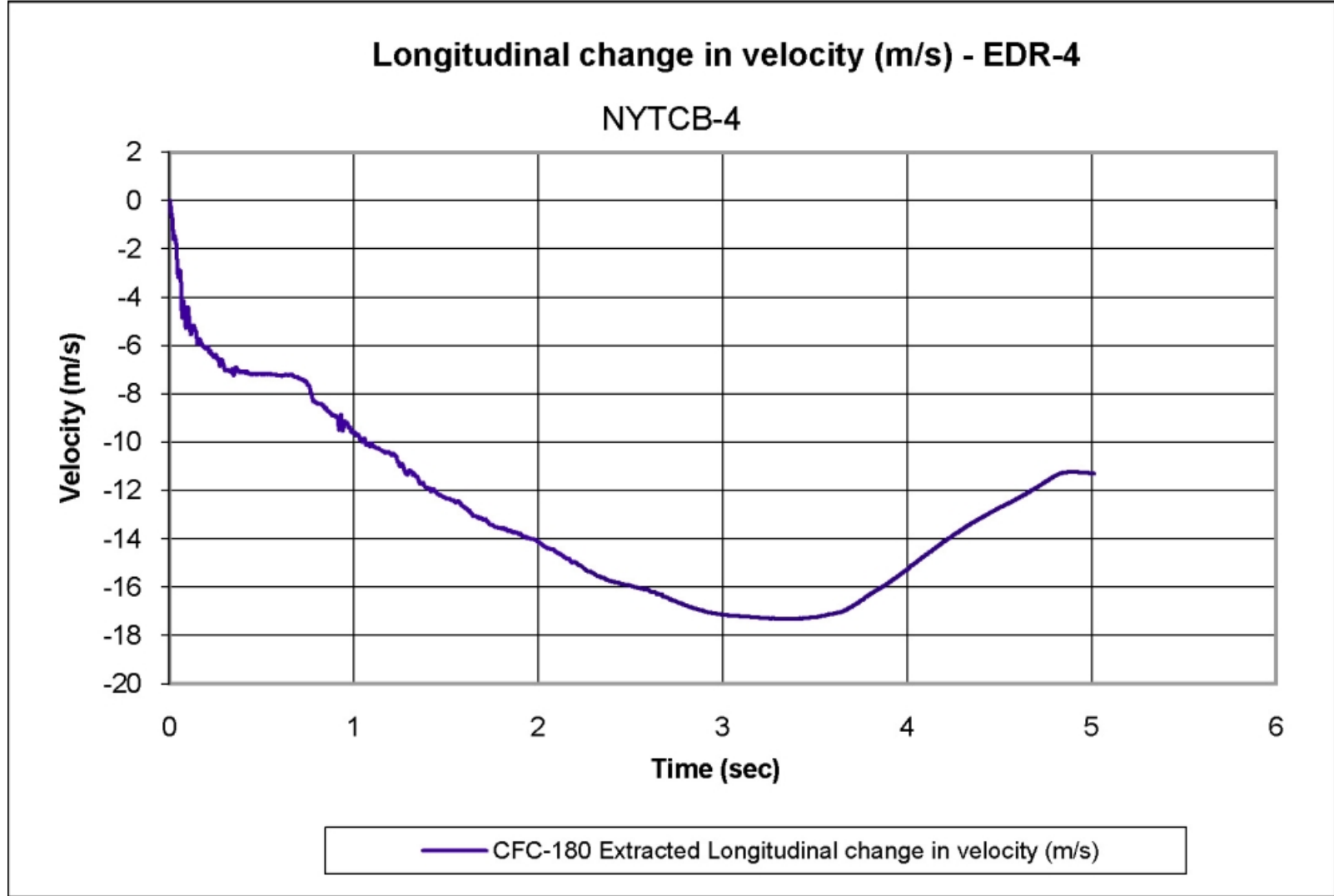

Figure D-2. Graph of Longitudinal Occupant Impact Velocity (EDR-4), Test NYTCB-4

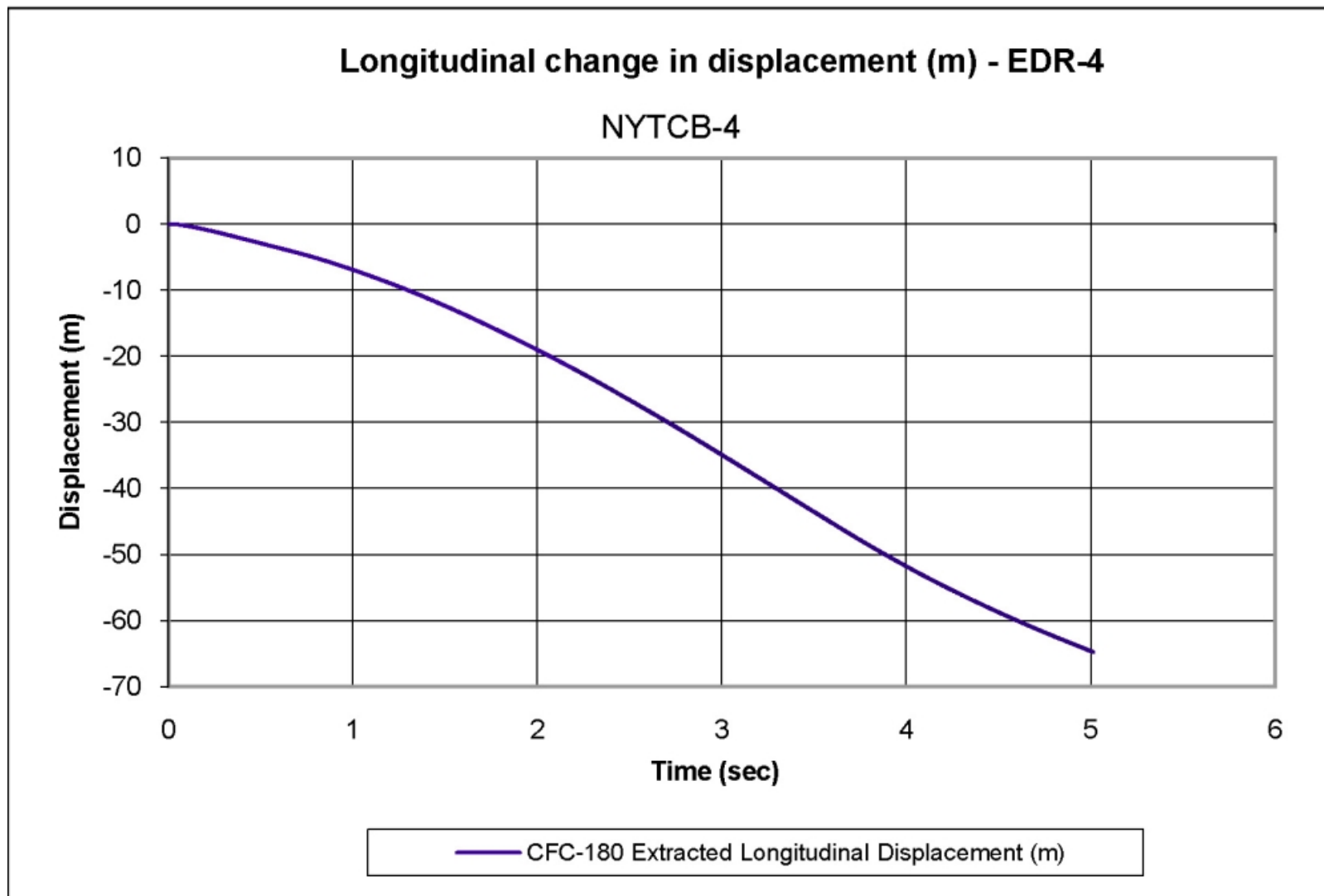

Figure D-3. Graph of Longitudinal Occupant Displacement (EDR-4), Test NYTCB-4

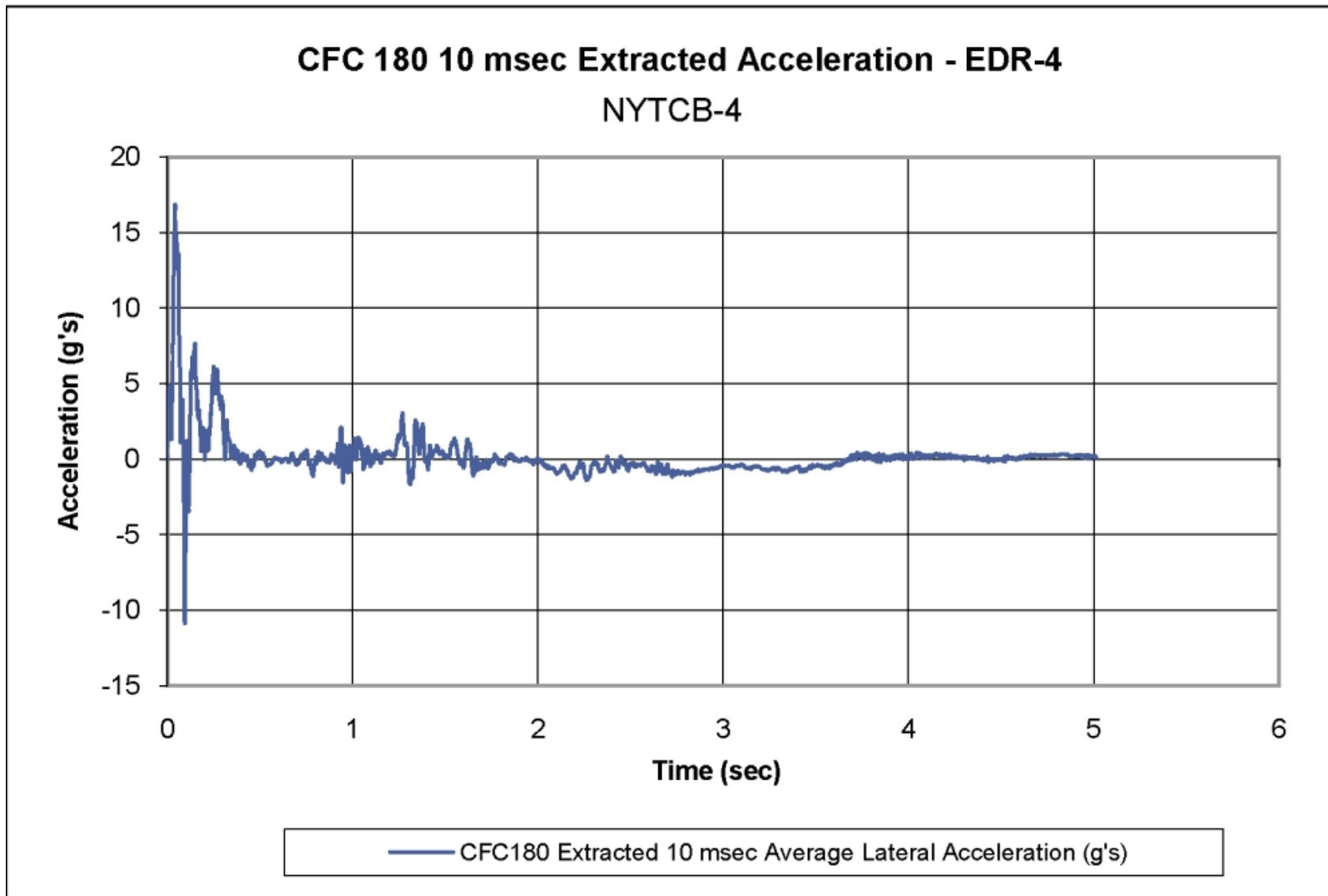

Figure D-4. Graph of 10 ms Average Lateral Deceleration (EDR-4), Test NYTCB-4

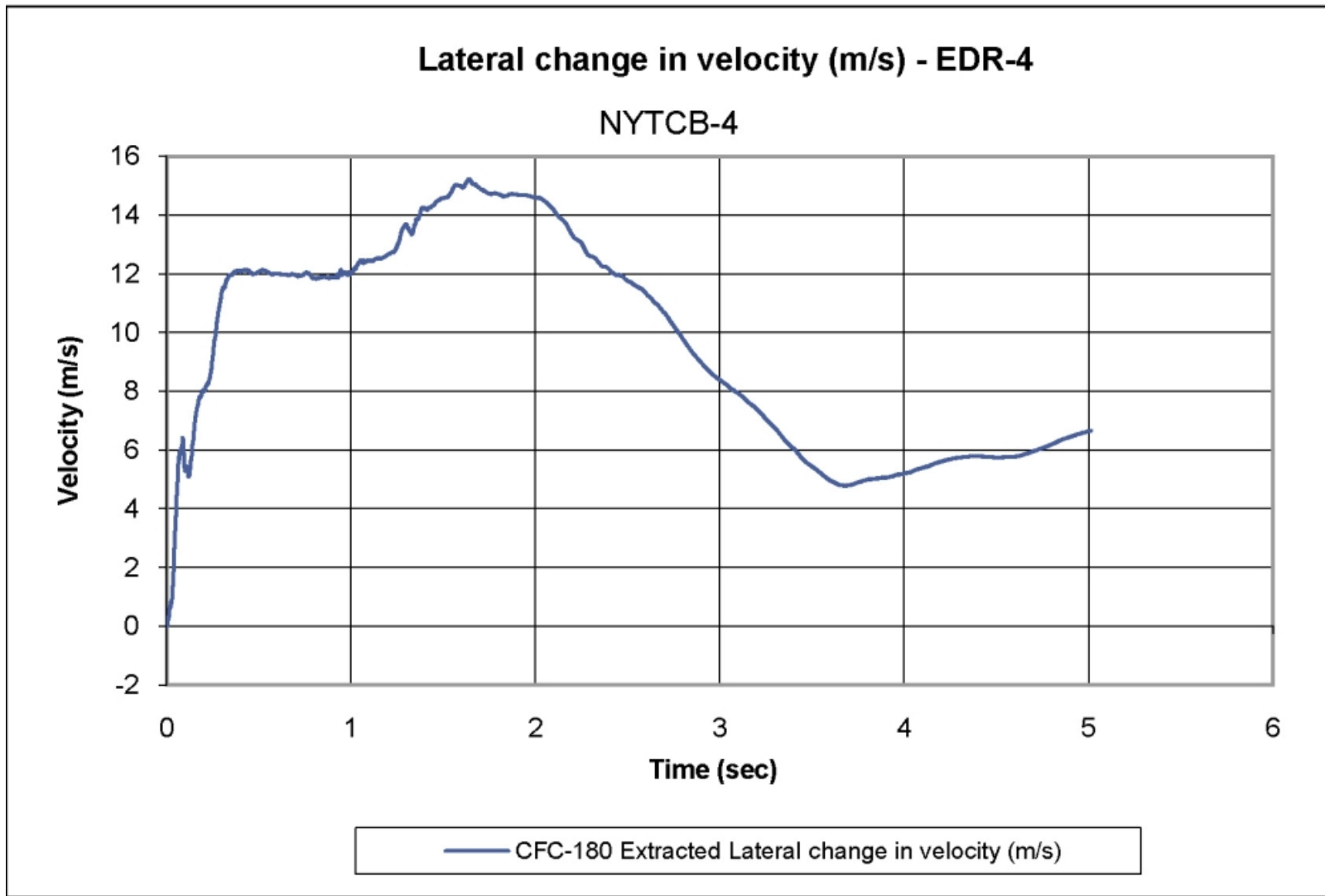
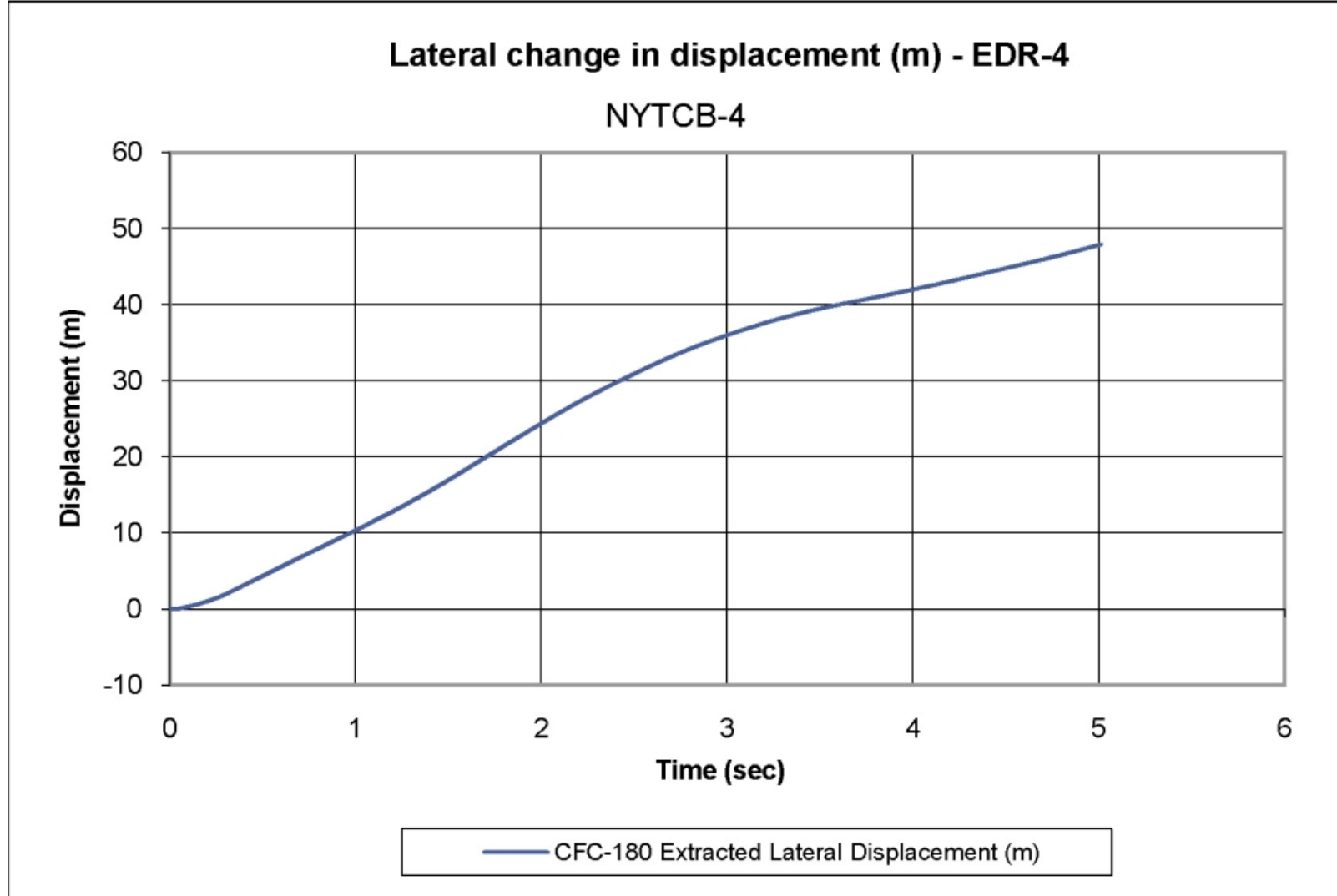
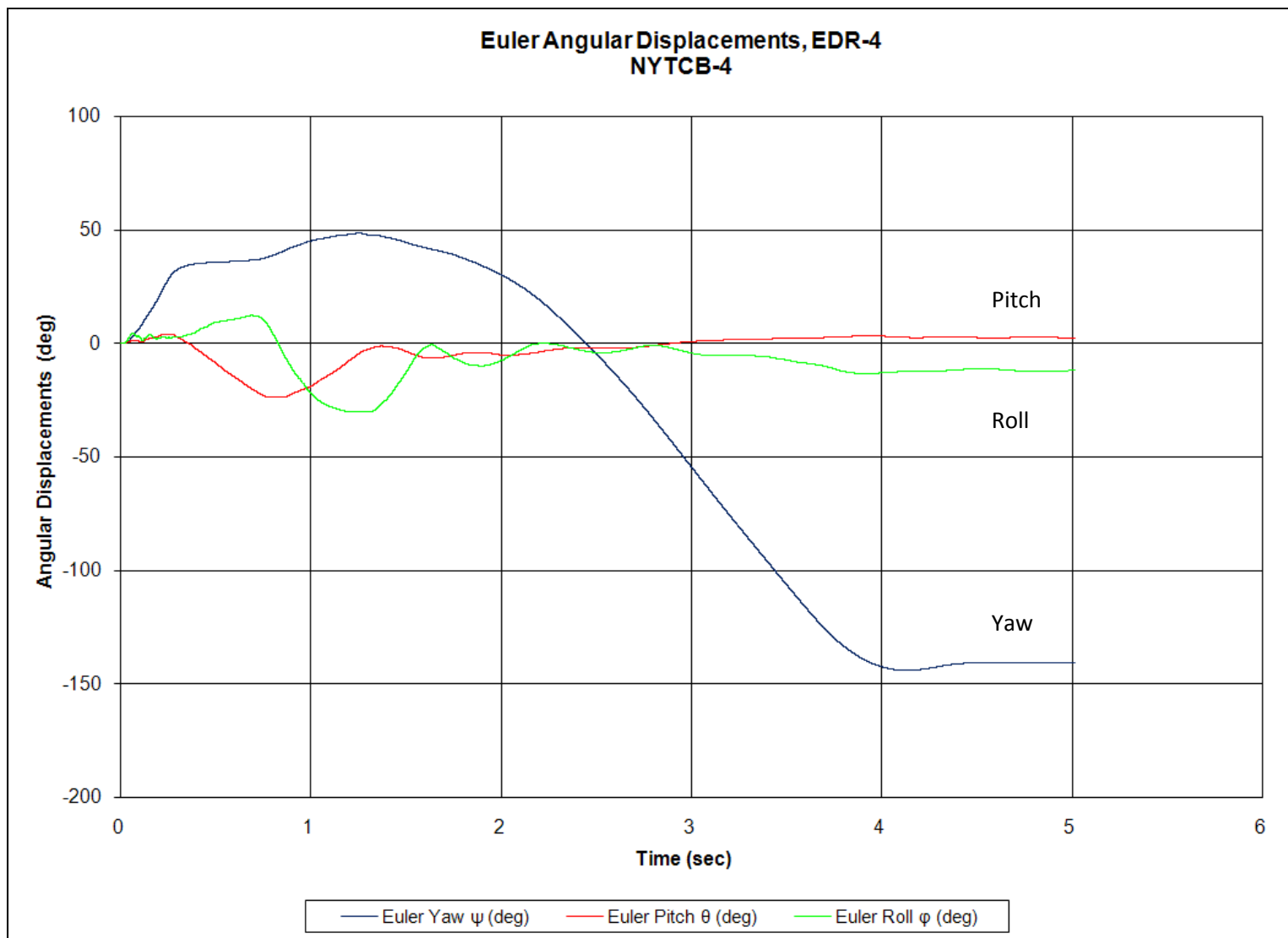

Figure D-5. Graph of Lateral Occupant Impact Velocity (EDR-4), Test NYTCB-4



**Figure D-6. Graph of Lateral Occupant Displacement (EDR-4), Test NYTCB-4**



**Figure D-7. Roll, Pitch, and Yaw Angular Displacements (EDR-4), Test NYTCB-4**

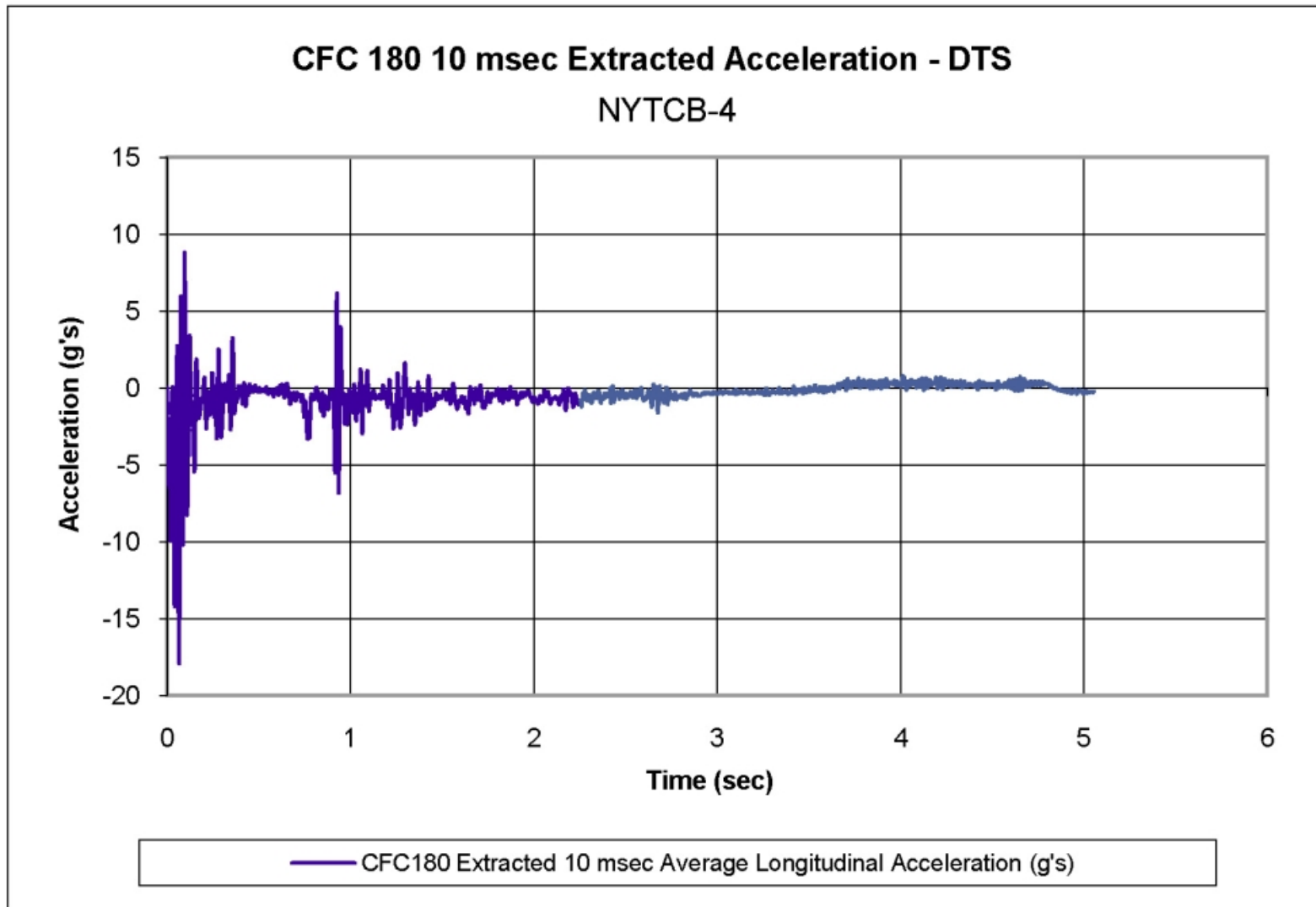

Figure D-8. Graph of 10 ms Average Longitudinal Deceleration (DTS), Test NYTCB-4



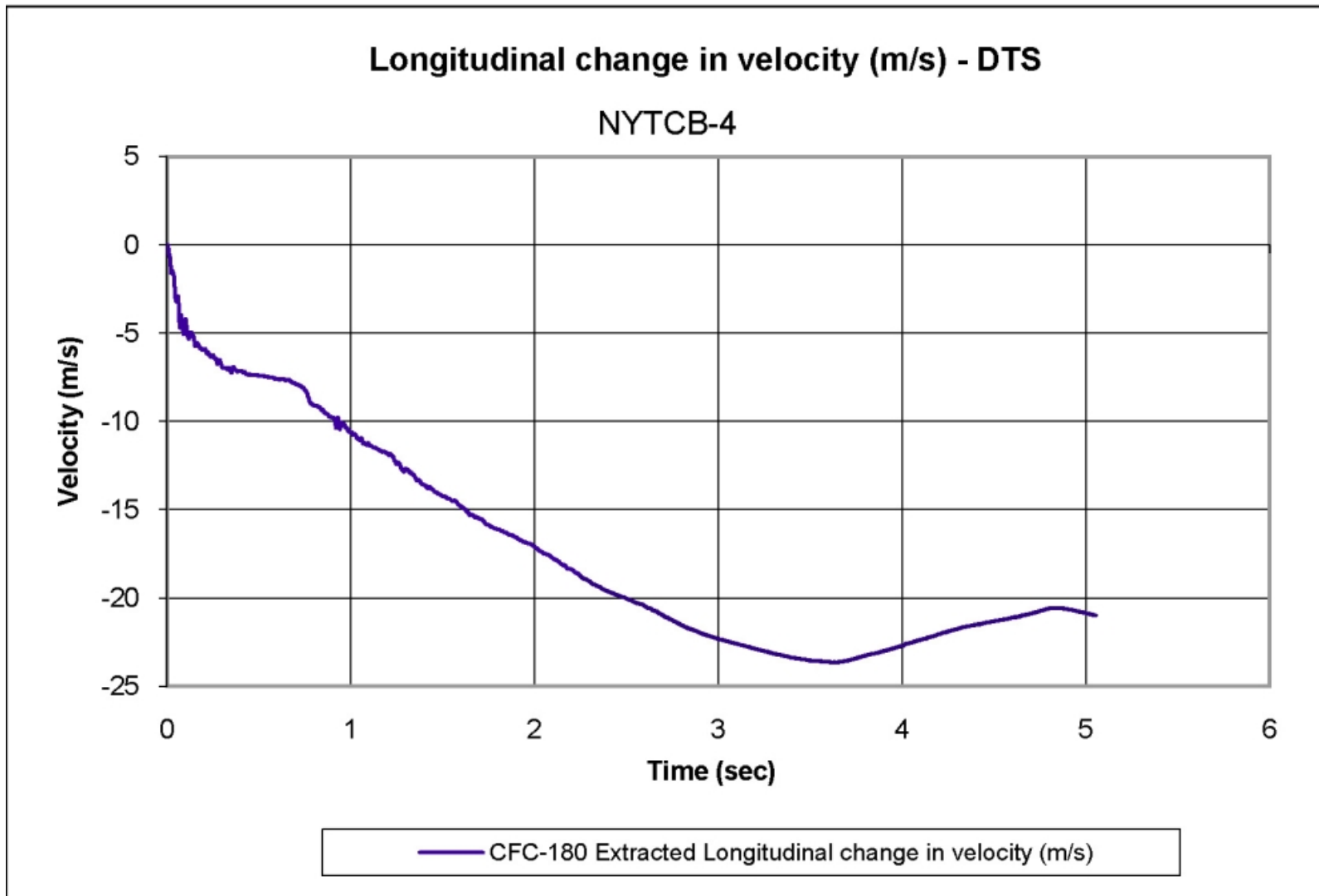

Figure D-9. Graph of Longitudinal Occupant Impact Velocity (DTS), Test NYTCB-4

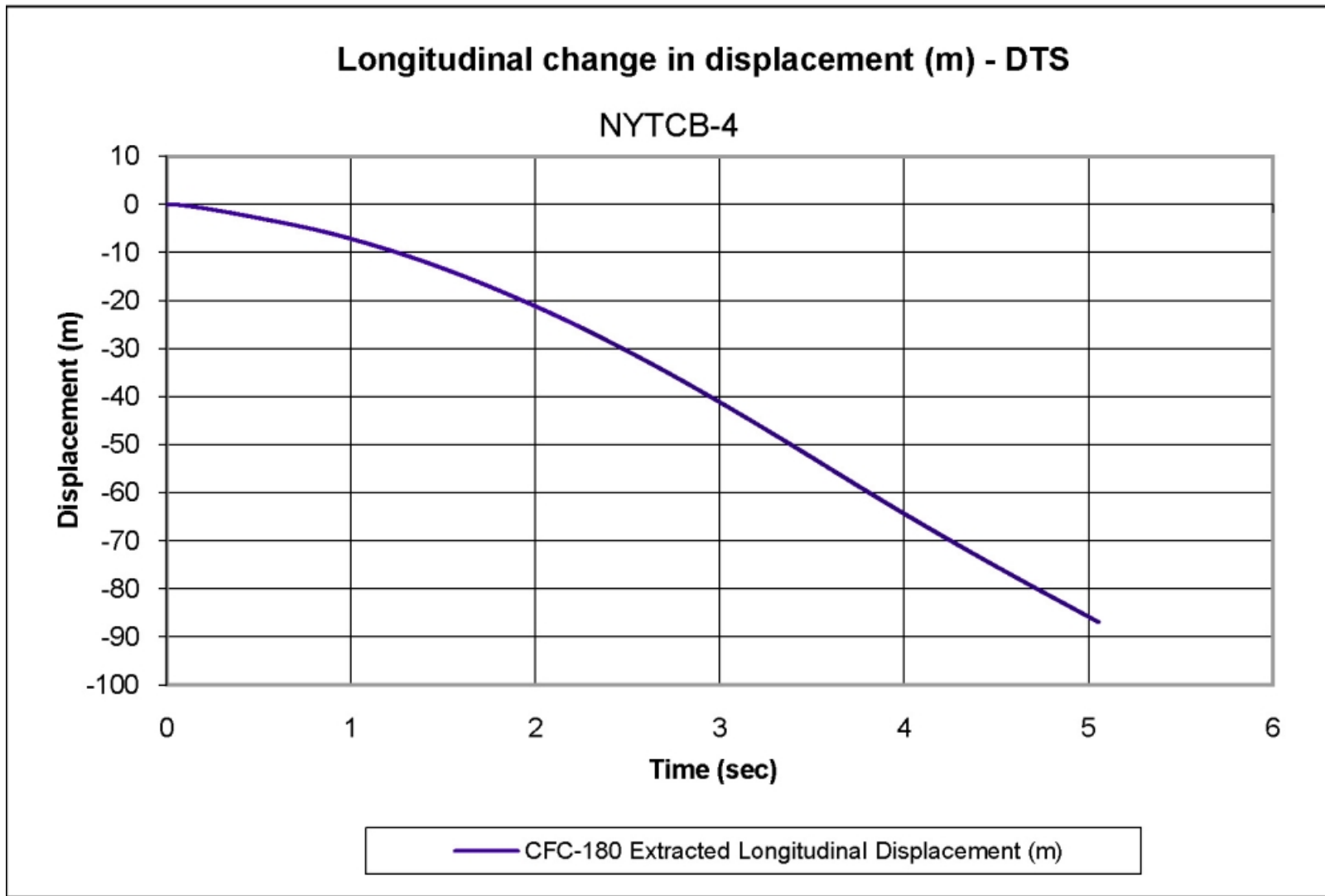

Figure D-10. Graph of Longitudinal Occupant Displacement (DTS), Test NYTCB-4

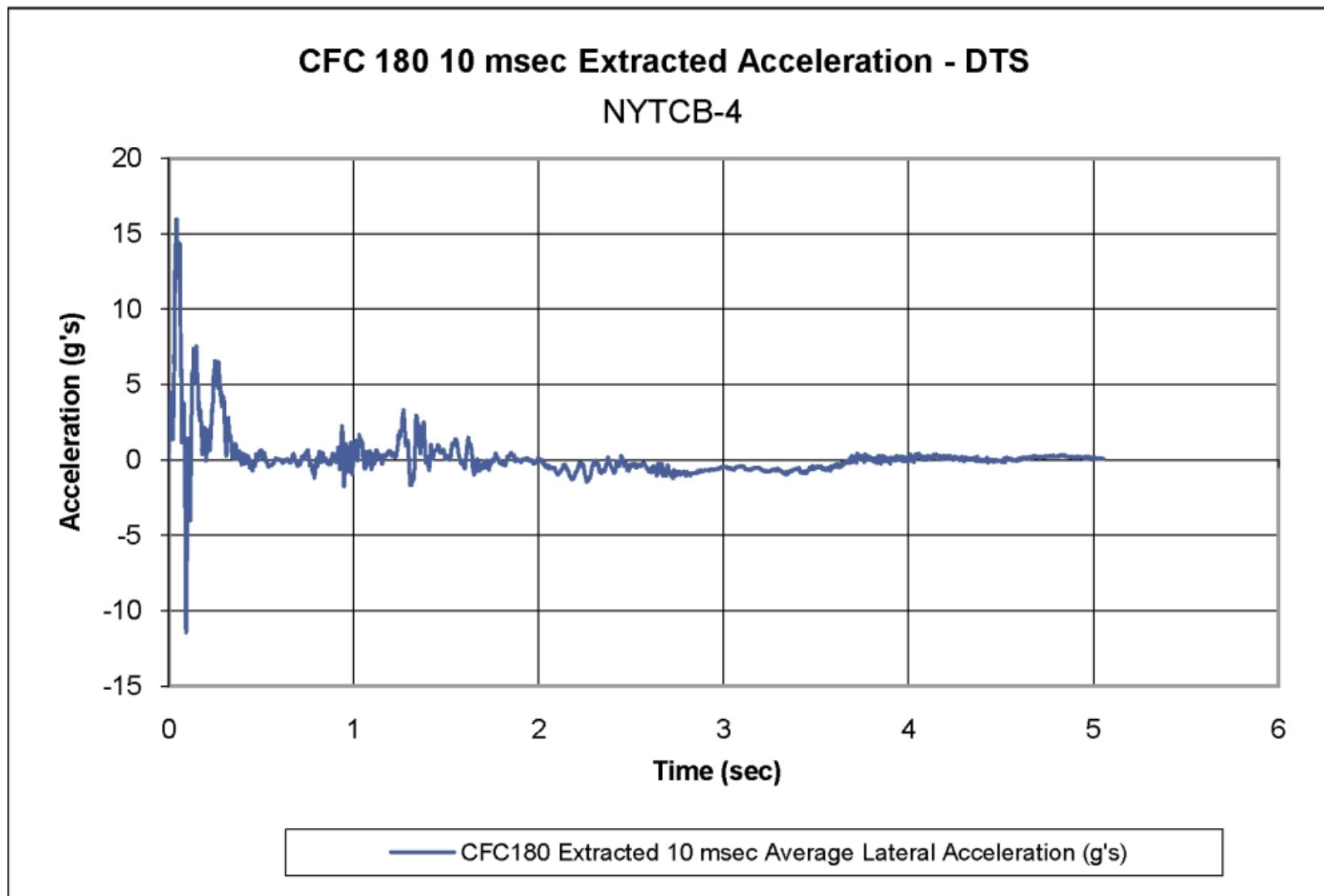
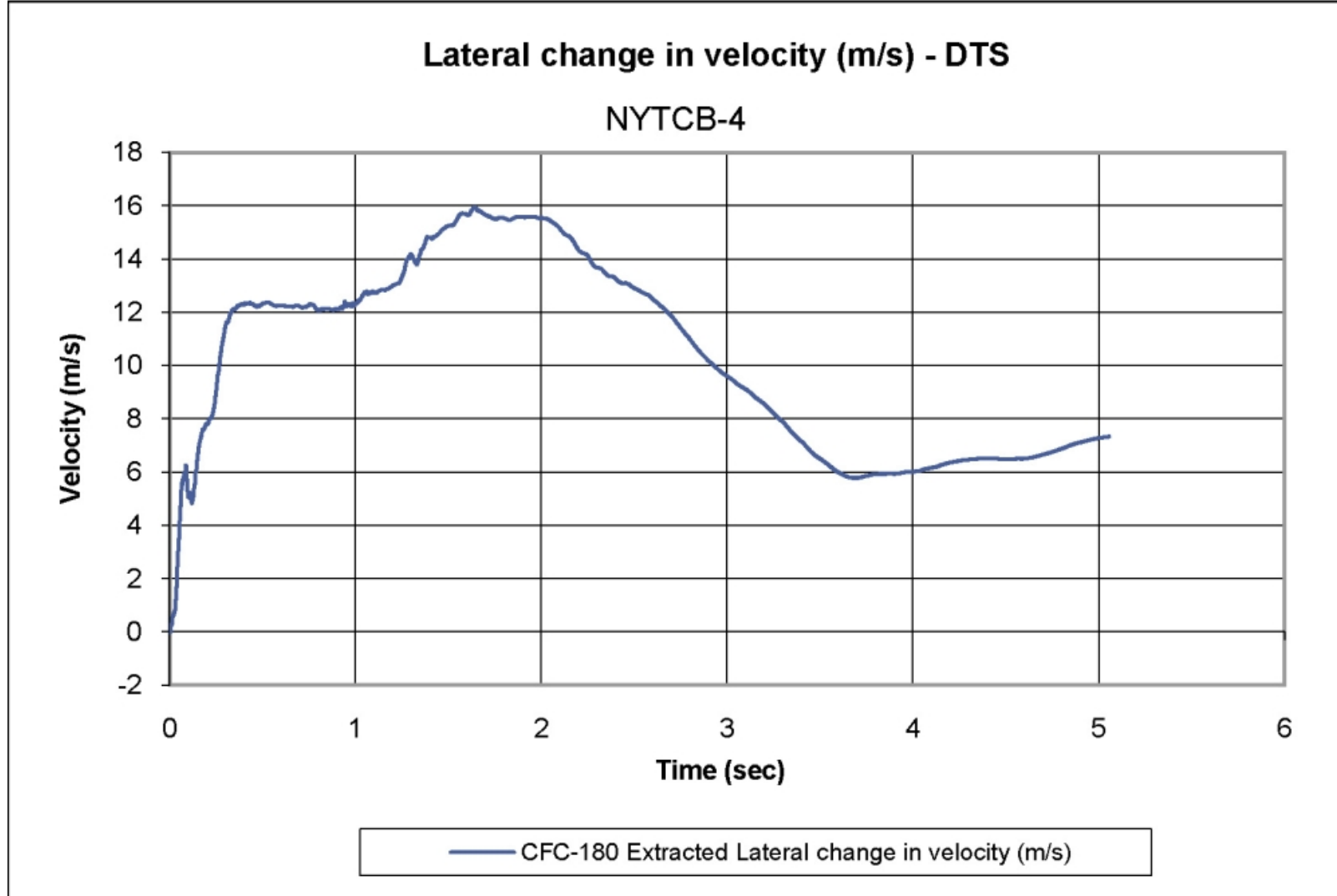

Figure D-11. Graph of 10 ms Average Lateral Deceleration (DTS), Test NYTCB-4



**Figure D-12. Graph of Lateral Occupant Impact Velocity (DTS), Test NYTCB-4**

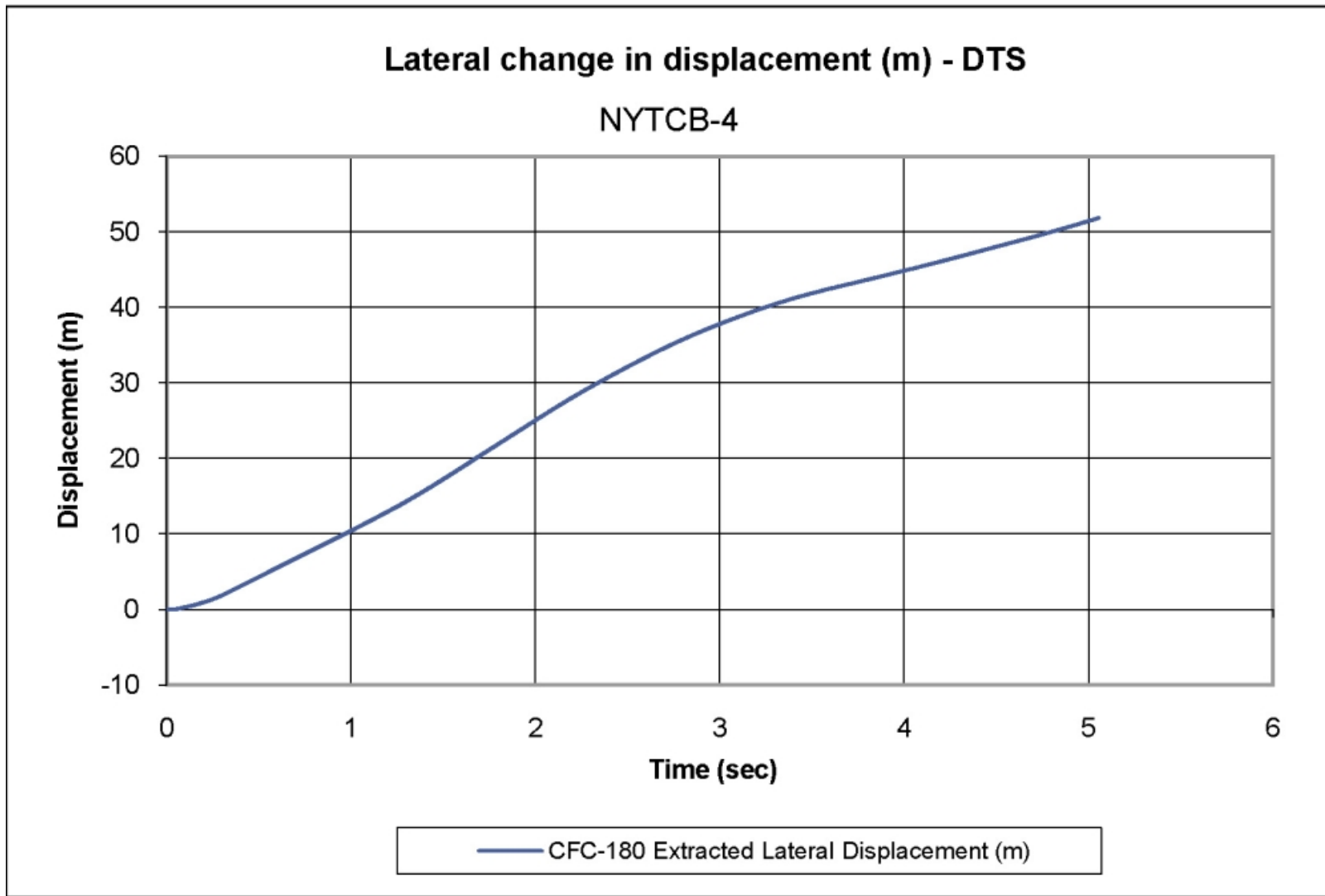
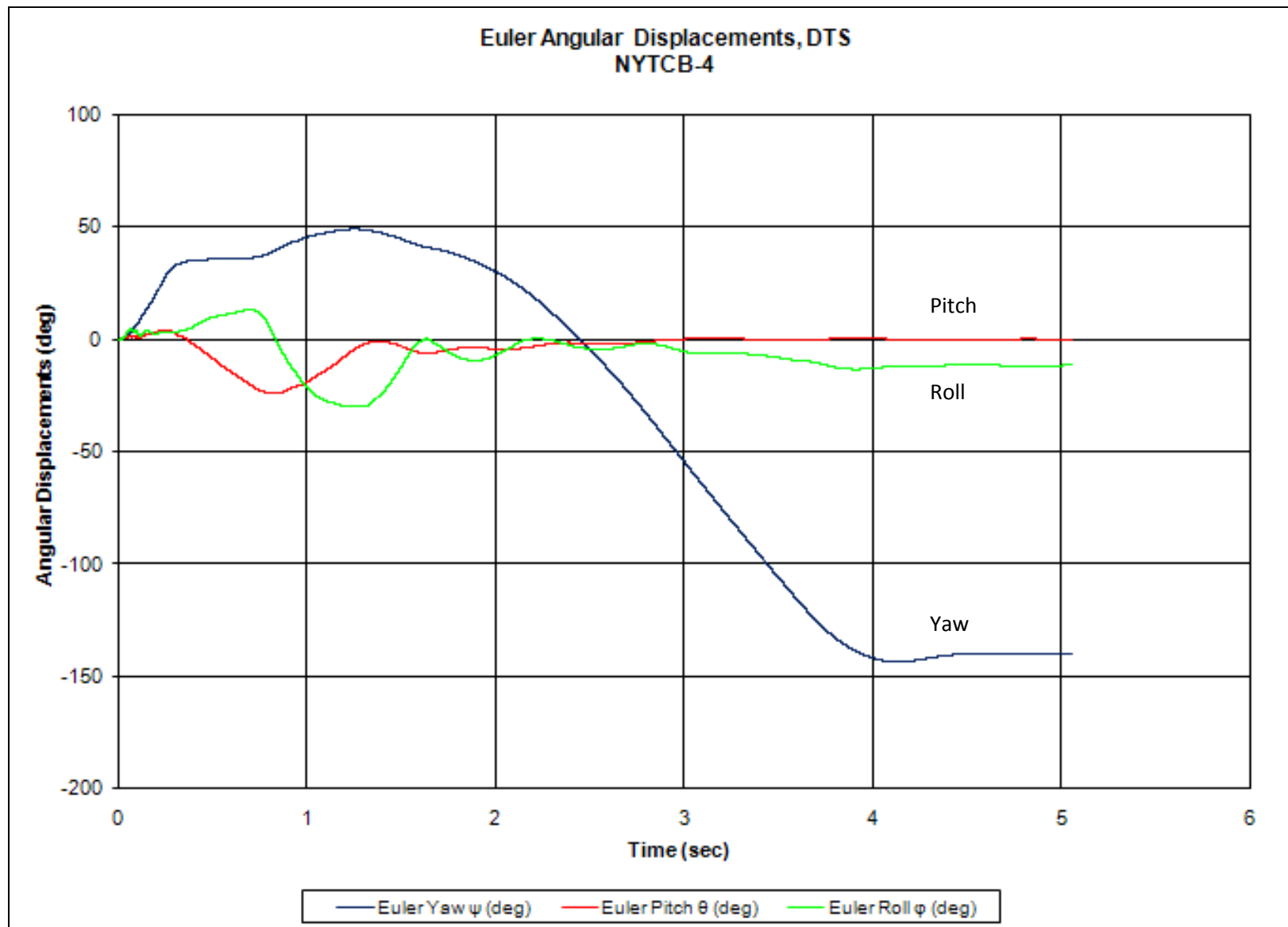

Figure D-13. Graph of Lateral Occupant Displacement (DTS), Test NYTCB-4



**Figure D-14. Roll, Pitch, and Yaw Angular Displacements (DTS), Test NYTCB-4**

**END OF DOCUMENT**