

University of Zagreb

Faculty of Humanities and Social Sciences

Department of English

2012/2013

Vedrana Marinović

Ditransitive Constructions in English and Croatian

Master's Thesis

Mentor:

Irena Zovko Dinković, PhD

Zagreb, 2013

Contents

1. Introduction.....	4
2. Syntactic theories dealing with ditransitive constructions.....	7
2.1 Introduction.....	7
2.2 Relational Grammar.....	8
2.3 Generalized Phrase Structure Grammar.....	10
2.4 Government and Binding Theory.....	12
2.5 Lexical Functional Grammar.....	14
2.6 Role and Reference Grammar.....	15
2.7 Information Structure.....	18
2.8 Construction Grammar.....	22
3. Cognitive grammar.....	25
3.1 Towards Cognitive Grammar.....	25
3.2 Cognitive Grammar.....	27
3.3 Ditransitive constructions in Cognitive Grammar.....	31
4. Ditransitive constructions and dative alternation in Croatian.....	32
5. Research.....	33
5.1 Participants.....	34
5.2 Methods.....	35
5.3 Results and discussion.....	38
5.3.1 Native speakers of English.....	38
5.3.2 Students of English (native speakers of Croatian).....	41
5.3.3 Native speakers of Croatian.....	43

5.3.4	Native speakers of Croatian (students of English).....	51
5.3.5	Native speakers of Croatian (students of Croatian).....	56
6.	Final remarks.....	61
7.	Conclusion.....	62
8.	Appendix 1.....	64
9.	References.....	77

1. Introduction

The aim of this paper is to provide an analysis of sentences with ditransitive constructions in English and Croatian. More specifically, we deal with sentences that undergo the so-called ‘dative alternation’, or ‘dative shift’. The question of ditransitive constructions and the phenomenon of dative alternation have been dealt with by various syntactic theories (e.g. Perlmutter 1980, Gazdar *et al.* 1985, Bresnan 1982, Van Valin 1993, Van Valin & LaPolla 1997). We first give a short overview of those syntactic theories, both of formal and functional approach, and then present the issue from the point of view of cognitive linguistics, that is, cognitive grammar. Our claim is that the phenomenon of dative alternation in ditransitive constructions is best explained precisely by cognitive grammar, because, apart from syntax, it also takes into account semantics, our experience and our knowledge of the world. We therefore consider ditransitive constructions and dative alternation from the point of view of cognitive grammar and attempt to support our thesis by the results of the research we conducted. Although we mainly deal with this issue in English sentences, we also present and analyze its occurrence in Croatian sentences and try to compare the way in which these constructions function in the two languages.

Ditransitive constructions appear in sentences with ditransitive verbs, that is, the verbs that take two objects. An example of this kind of sentence would be

(1) John gave a book to Mary.

This sentence presents a canonical ditransitive construction in English¹. In this kind of construction *a book* is usually referred to as direct object and *to Mary* as indirect object. However, indirect objects in these types of constructions can sometimes become direct objects without affecting the meaning of the sentence as a whole. This change in syntactic relations is commonly known as ‘dative alternation’ or ‘dative shift’. Therefore, when dative alternation occurs, we get a sentence of this form:

(2) John gave Mary a book.

¹ Dryer (1986) gives a different view on which sentence presents a canonical ditransitive construction

Now *Mary* is the direct object, whereas *a book* becomes the indirect object, although the appropriateness of the terms direct and indirect object is often debated (cf. Dryer 1986).

Not all English verbs allow dative alternation; there are some thirty verbs that do, such as

answer, bid, cause, deny, entrust, envy, give, hand, leave, lend, offer, owe, pass, preach, promise, read, recommend, refuse, sell, send, show, sing, teach, telephone, tell, wave, write.

Some of those verbs are used frequently, some less frequently, but what they all have in common is the fact that in a ditransitive construction apart from a direct object they can also have a prepositional expression in the form of *to/for* + NP² which functions as an indirect object. In dative alternation this type of indirect object becomes the direct one (Zovko 2001: 4).

When it comes to ditransitive constructions and dative alternation, the issue of cases is worth mentioning. This is especially important for Croatian, since it is a case-marking language, but case has been an issue in English, too. With regard to English, the main issue has always been whether cases are a morphological, syntactic or semantic category. This issue was addressed from two main points of view – in the first one cases were considered morphological categories in the surface structure having certain syntactic functions in a sentence. The second approach considered cases to be abstract categories in the deep structure that are realized in the surface structure by different formal means (cf. Zovko 2001). Contemporary English is not a case-marking language, although some claim that the case system has been preserved in personal pronouns, especially the dative case, for example, *I* is considered to be in the nominative case whereas *me* is believed to be in the oblique case, that is, dative. The existence of these claims, that English indeed does have some cases, has led to extensive research on cases. Some linguists, like Jespersen (1924), dismissed the idea that there are cases in English like those in Latin, claiming that cases are entirely syntactic categories, not morphological. Chomsky (1965) claimed that cases depend on transformational rules and therefore cannot be a part of the deep structure. Perhaps the most influential approach to cases was presented by Fillmore (1968) who describes cases as abstract universal categories. In the beginning Fillmore differentiated between six cases of the deep structure – *Agentive, Instrumental, Dative, Factitive, Locative* and *Objective*, mentioning also *Benefactive, Time* and *Comitative*.

² Abbreviations S, NP, VP, PP and V are widely accepted in linguistics as symbols representing sentence constituents. They designate sentence, noun phrase, verb phrase, prepositional phrase and verb respectively.

Fillmore updated his list of cases several times, leaving some of them out and adding new cases, finally reaching the list of eight cases – *Agent, Counter-Agent, Object, Result, Instrument, Source, Goal, Experiencer* (Zovko 2001). Important for the topic of our analysis is the fact that Fillmore left out the *Dative* from his list of cases and broke it up into *Experiencer, Goal* and *Object*, thus specifying how the animate being is affected by the state or action (Szabone 2003). Fillmore's cases can be equated neither with the surface cases in inflective languages which are a morphological category, nor with syntactic functions like subject and object, since a given deep case can be realized in the surface structure in different ways. Fillmore's theory was met with a lot of criticism, but it also influenced a large number of subsequent theories, including those of Chafe (1970) and Cook (1979), who emphasized the importance of semantics and the verb as the central sentence element. To quote Cook (1979:44),

‘In any simple sentence the verb is central and has one and only one case frame. This case frame is an explicit array of cases intimately related to the meaning of the verb. For any one meaning of the verb, there is one semantic configuration composed of a well-defined set of cases. The nouns in the proposition, on the other hand, are not cases but ‘case candidates’. (...) Nouns do not exist as cases. They assume case roles in propositions. The case role itself is read into the noun from the verb.’

The so-called deep cases became an integral part of many claims by functional syntax which developed significantly in the 1980s (e.g. Chafe 1970, Cook 1979, Van Valin 1993). This kind of a functional approach proved very useful in analyzing the nature of constructions such as dative alternation (Zovko 2001).

Croatian also allows ditransitive constructions. Since it is a case-marking language, it is usually easy to differentiate between direct and indirect objects – a prototypical direct object is in the accusative case, whereas a prototypical indirect object is in the dative case. However, several combinations of double objects are possible, for example: object in accusative + object in genitive; object in accusative + object in instrumental; object in dative + object in instrumental. Moreover, some verbs allow the combination of an object in the accusative or dative case and a prepositional object, either in the accusative or locative case (Barić et al. 1997: 442-444). Although it is rare in case-marking languages, the phenomenon of dative

alternation is present in Croatian, too. However, only a small number of Croatian verbs allow dative alternation. An example would be sentences like

(3) Ivan je Mariji darovao knjigu.

(4) Ivan je Mariju darovao knjigom.

In the sentence (3), *Mariji* is an object in the dative case, whereas *knjigu* is an object in accusative. In the sentence (4), *Mariju* is an object in accusative, whereas *knjigom* is an object in the instrumental case. What this actually means is that the recipient argument can be expressed in two ways, either as the object in dative or as the object in accusative.

Dative alternation is much more than a simple change of syntactic relations in a sentence. Its existence touches upon many important issues dealt by syntactic theories, such as the problem of defining direct and indirect objects and the relevance of syntactic functions in a given language, the question of transitivity, and the problem of determining the role of semantics, pragmatics (language use) and discourse in dative alternation. It is not then surprising that many theories try to analyze ditransitive constructions exhibiting dative alternation. As mentioned above, we focus mainly on the analysis of this phenomena presented by cognitive grammar because we consider its claims to be the most appropriate when dealing with ditransitive constructions and dative alternation.

2. Syntactic theories dealing with ditransitive constructions

2.1 Introduction

Syntactic theories differ mainly in the way they understand and explain some of the major subjects of syntactic analysis, including ditransitive constructions and dative alternation. Theories such as Relational Grammar (Perlmutter 1980), Generalized Phrase Structure Grammar (Gazdar *et al.* 1985), Lexical Functional Grammar (Bresnan 1982) or Role and Reference Grammar (Van Valin 1993, Van Valin & LaPolla 1997) differ in methods and the way of representing syntactic structures, but also depending on how incorporated semantics is in the syntactic analysis. Although only Relational Grammar and Lexical Functional Grammar grew directly out of Transformational Generative Grammar (Chomsky 1957, 1965), all these theories aim to create a theoretical framework within which it would be possible to

formulate grammars capable of explaining all grammatical sentences in a given language. This is why, in a very broad sense, we could call these theories generative. However, in a narrower sense, the concept of generativity is related primarily to various approaches falling under Principles and Parameters Theory (Culicover 1997 *et al.*), such as, for example, Government and Binding Theory (Chomsky 1981) (Zovko 2001).

Syntactic theories also differ in the way they describe language. Here we differentiate between two basic approaches – formal and functional. Formal approaches see language as a set of grammatical sentences that need to be described without reference to the communicational function of language. Syntax is regarded as autonomous and the most important component, it is considered irrespective of semantics and pragmatics and as having priority over them. All the formal theories generally function within the conceptual framework developed by Chomsky in his Transformational Generative Grammar. On the other hand, functional approaches emphasize the communicational aspect of language, denying the autonomy of syntax, its priority and the existence of different syntactic levels; it is considered that morphosyntax can only be understood and explained in relation to semantic and pragmatic functions of its components. Functional approaches aim not only to describe language competences of the speaker, but also what the speaker knows about using language in different communicational situations. Dative alternation is considered one of the morphosyntactic phenomena in which there is a change in syntactic relations which is why many theories have dealt with its analysis (Zovko 2001). In this chapter we will present different approaches to this construction within several theories of formal and functional orientation.

2.2 Relational Grammar

Relational Grammar (RG) refers to a formal approach to syntax that takes grammatical relations like subject, direct object, and indirect object to be indispensable and primitive notions. According to Perlmutter (1980), they are indispensable for achieving three goals of linguistic theory: to formulate linguistic universals, to characterize the class of grammatical constructions found in natural languages, and to construct adequate and insightful grammars of individual languages. Whereas subject, direct object and indirect object are considered primitive notions because they cannot be defined universally in terms of

relations like linear order or dominance, all the other syntactic relations are defined by their semantic functions, e.g. benefactive or instrumental. As Zovko (2001) puts it, the graphic representation of clause structure in RG is abstract since it does not represent a concrete form of a given sentence; rather, syntactic relations are represented by numbers – 1 = subject; 2 = direct object; 3 = indirect object. In this way, sentences from two different languages with the same relational structure would have the same representation in RG, regardless of the morphosyntactic differences between those two languages.

A crucial assumption of RG, inherited from Transformative Generative Grammar, has been that the description of a clause refers not only to its superficial structure, but also to a deeper structure and possibly to several intermediate levels of structure. In RG, these levels are called strata, and the RG position is that there is no one stratum at which all the properties associated with subject or object hold; rather these are apportioned at different strata. Relations in the initial stratum are linked to semantic roles, e.g., agent, patient (Rosen 1984), whereas relations in the final stratum determine more superficial phenomena like agreement and word order. Clause pairs such as active/passive or dative alternation which express the same proposition in relationally different ways generally share the same initial stratum, accounting for their synonymy, but diverge in later strata (Perlmutter and Postal 1983). Therefore, when it comes to constructions such as dative alternation (in which there is a change in syntactic relations) Relational Grammar introduces a special syntactic relation called *chômeur* for those arguments that lose their status of the primitive, such as the initial subjects of passive constructions. Dative alternation reflects the rule called 3-to-2 advancement (Zovko 2001). For example, in sentences like

(5) John gave a book to Mary. 1 – P – 2 – 3

(6) John gave Mary a book. 1 – P – 2 – 2

there is an advancement of indirect object, *to Mary*, to direct object, *Mary*. Therefore, the initial indirect object of the first sentence/initial stratum, represented by 3 in Relational Grammar, has been advanced to 2, that is, to direct object. By analogy, the initial 2 has become a *chômeur* (lit. an ‘unemployed’ function), also represented by 2 in the second stratum. As direct object, *Mary* may advance further to subject in the passive version/third stratum, in which case we get the following sentence

(7) Mary was given a book by John.

The initial stratum in Relational Grammar, therefore, corresponds to the deep structure in Transformative Generative Grammar, and the final stratum is analogous to the surface structure.

RG played an important part in the evolution of syntactic theory from the 1970s to the 1980s. During this period, languages other than English had significant impact on syntactic theorizing, leading to an increased appreciation of linguistic universals, and the need to distinguish more clearly between the universal and the language-particular. RG represents one early response to these issues (Aissen 2013). In the beginning, it took over transformational rules from Transformative Generative Grammar, but later on it turned them into relational rules. This happened because transformations were language-specific, whereas Relational Grammar with its relational rules managed to create many important generalizations about syntactic constructions in the form that was applicable to more than one language. Its main contribution lies in the fact that at the time when majority of linguistic theories dealt exclusively with English, it introduced a variety of important generalizations by studying many different languages and offered some very interesting solutions. However, some of its main claims still remain debatable.

2.3 Generalized Phrase Structure Grammar

Generalized Phrase Structure Grammar (GPSG) was initially developed in the late 1970s by Gerald Gazdar. As opposed to Relational Grammar, GPSP completely ignored syntactic relations and based its analysis exclusively on English. GPSG presents an attempt to describe the syntax of natural languages with the help of grammar consisting only of the rules of syntactic structure (Zovko 2001). In other words, it tries to show that the syntax of natural languages can be described by context-free grammars and it introduces a sophisticated feature structure system and the so-called "meta-rules", which are rules generating the production of a context-free grammar (Gazdar et al. 1985). In this way, GPSG opposes Transformational Generative Grammar and Chomsky who claimed that those rules are not enough to describe the syntax of natural languages adequately.

As already mentioned, GPSG introduces the concept of syntactic features, whose value is either (+) or (-), but there are also those features whose values are the entire categories. For example,

- (8) [N] {+, -}
 [V] {+, -}
 [SUBJ] {+, -}
 [CASE] {NOM, ACC, DAT, GEN} etc.

S, NP, VP, and V are represented as matrices that specify syntactic features of the corresponding syntactic categories. In GPSG, syntactic relations have no theoretical status and thematic relations are absent, too. Since GPSG is a theory that allows only one level of representation, there are no abstract representations of deep structure or transformational rules. Therefore, GPSG has a different approach to describing constructions in which there is a change in syntactic relations – it introduces the so-called "meta-rules". These are the rules that express systematic relations between lexical rules of immediate dominance (ID) that define mutually related pairs of sentences.

However, dative alternation is not explained by a meta-rule. For example, the verb *give* can appear in the verb phrase that has the form as in the sentence

- (9) John gave a book to Mary.

but it can also appear in the verb phrase that has the form as in the sentence

- (10) John gave Mary a book.

In GPSG, the verb *give* in these two forms would be subcategorized as V [4] and V [5]. Many verbs have more than one subcategorization which is why shared semantic characteristics among different verb phrases in which a verb can occur are explained by semantics more than syntax.

GPSG therefore solves the problem of dative alternation by subcategorizing each verb differently. However, at the same time this solution also presents the problem of this kind of an approach. Namely, GPSG places subcategorization into syntax, whereas it disregards syntactic and thematic relations. Arguments of the verb *give* in the sentences (9) and (10) remain semantically the same – the one who gives, the one who receives and the thing that is given – which is why there is no need to subcategorize the verb *give* in two separate ways, as well as any other verb that allows dative alternation (Zovko 2001).

2.4 Government and Binding Theory

Government and Binding Theory (GB) was developed by Noam Chomsky in the early 1980s and it grew directly out of Transformational Generative Grammar. GB assumes that a large portion of the grammar of any particular language is common to all languages, and is therefore part of Universal Grammar. The GB view is that Universal Grammar can be broken down into two main components: levels of representation and a system of constraints.

GB assumes a derivational model consisting of four levels of representation, as diagrammed in (11). The lexicon lists the idiosyncratic properties of lexical items which constitute the atomic units of the syntax. These properties include what arguments the item subcategorizes for, etc. Lexical items are combined together at D-structure (underlying structure). D-structure is mapped into S-structure, which is the syntactic representation that most closely reflects the surface order of the sentence. S-structure is not directly interpreted itself, but is factored into Phonological Form (PF) and Logical Form (LF). PF is the interface with the Phonology where shapes, sounds, and groupings of items are directly represented. LF is the interface with the Semantics. Predication relationships and the scope of quantifiers and operators of various kinds are explicitly represented in the phrase structure at LF.

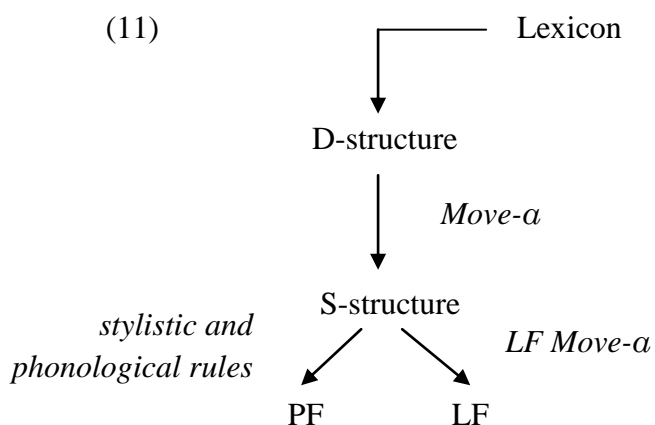

These levels are related to one another by rules (noted in italics in (11)). A single movement rule, *Move-a*, maps between D-structure and S-structure and a similar rule maps S-structure into LF. *Move-a* is stated as a simple rule basically allowing anything to move anywhere, since the system of constraints is responsible for correctly restricting this movement. Stylistic and other phonological rules are assumed to take place at PF (Black, 1999).

In GB, there are no rules for deriving syntactic structures so the deep structure is projected from subcategorizational data in the lexicon. The deep structure acquired in this way must be in accordance with the so-called *X-bar* schema which provides the representation on all levels. General *X-bar* structure of a sentence has the following form

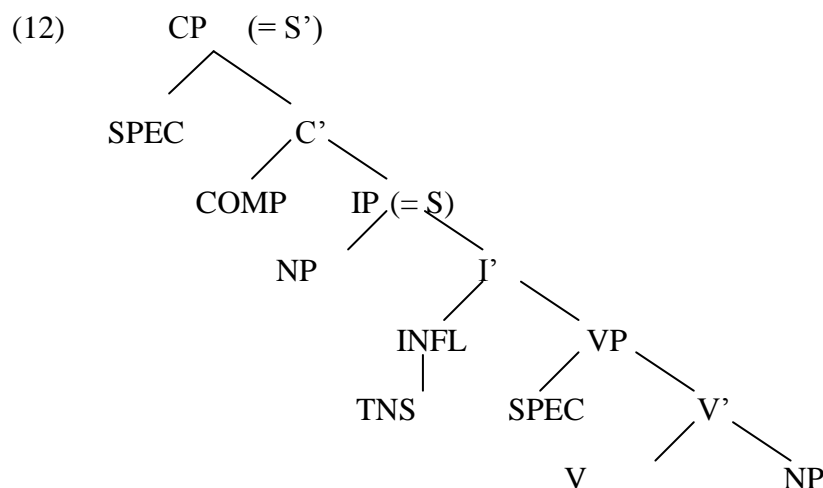

Government and Binding Theory acknowledges only two syntactic relations: subject and direct object. Traditional indirect object is considered simply as prepositional object. Subject is usually called the external argument because it is outside of the verb phrase, whereas direct object is called internal argument since it is inside the verb phrase. Thematic relations between the predicate and its arguments are called *theta* (θ -) *roles*. According to the *Uniformity of Theta Assignment Hypothesis* agent is realized as the external argument, whereas patient is realized as the internal argument.

In Government and Binding Theory there are no rules specific to certain specific constructions such as dative alternation. Rather, they are considered to be the result of interaction between a certain number of universal principles. Chomsky believed that sentences like

(13) John gave Mary a book.

derive from the structure of sentences like

(14) John gave a book to Mary.

by the extraposition of the prepositional phrase, in our case *to Mary*, where indirect object is actually some sort of 'internal object' which forms a constituent with the verb, excluding at

the same time the surface direct object. Indirect object (NP2) is, therefore, in the structural domain of the direct object (NP2), but not the other way around. Chomsky also believed that dative alternation is in its character transformational and resembles passive because the indirect object in the deep structure loses its case, and the subject of the verb phrase loses its θ -role.

Government and Binding Theory, just like Relational Grammar, presupposes several levels of syntactic representation, but it cannot be claimed with certainty that postulating multiple levels of representation of syntactic structure is justified in all languages. Besides, languages in which there is no verb phrase refute one of the central claims of GB – the one that all sentences in all languages have a verb phrase.

2.5 Lexical Functional Grammar

Lexical Functional Grammar (LFG) was developed by Joan Bresnan in the 1970s and it grew out of the classical Transformational Grammar. LFG combines some of the ideas present in GPSG and Relational Grammar at the same time dismisses transformational rules and the concept of abstract deep structure. LFG is unique because it takes into account both the structure of syntactic constituents (c-structure) and relational structure, that is, functional structure (f-structure). Syntactic relations are called syntactic functions, and when it comes to the analysis of constructions such as dative alternation the key role is assigned to lexicon, which is generally very important in LFG (Zovko 2001). According to Bresnan (1982), syntactic functions of simple sentences are divided as follows:

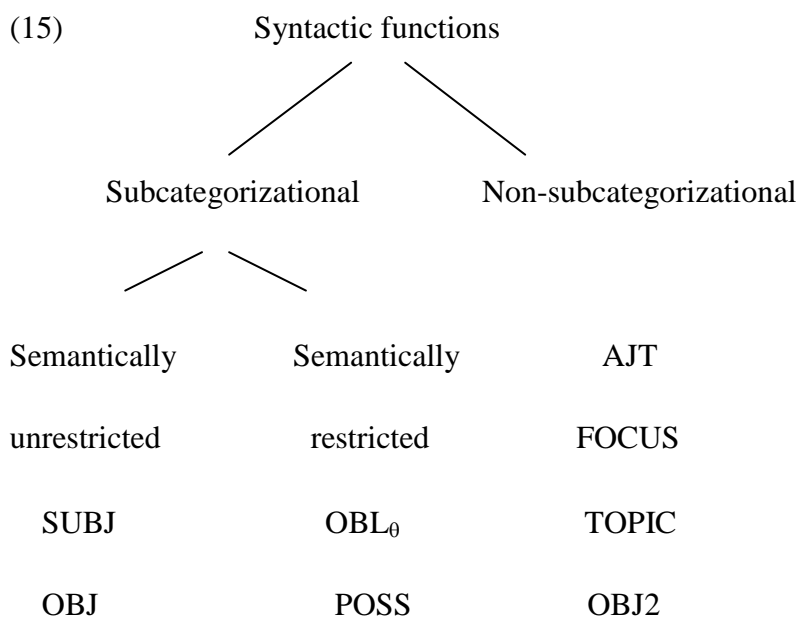

Semantically unrestricted functions are subject, direct object and secondary object, with the secondary object referring to *a book* in a sentence like *John gave Mary a book*. These functions are semantically unrestricted because the arguments that carry them can have a number of semantic roles, that is, they can represent various kinds of participants in what the predicate signifies. Therefore, *a book* has different semantic roles, but its function is the same, whereas semantically restricted syntactic functions such as OBL_{θ} ³ relate to precisely defined semantic roles, for example the recipient in the sentence *John gave a book to Mary*. Traditional indirect object such as *to Mary* is analyzed as OBL_{θ} (cf. Zovko 2001).

In LFG, lexical entry for a verb contains, among other things, its subcategorization and the structure of arguments, and it is called the lexical form. Thus, the changes in syntactic functions in constructions such as passive or dative alternation are considered as the changes in the lexical form of a verb. Since the rules that change the lexical form of a verb apply in the lexicon, they are called the lexical rules (Zovko 2001).

In this way, Lexical Functional Grammar expresses the systematic relations that exist in passive or dative alternation by the rules set in the lexicon, whereas Relational Grammar, Transformational Generative Grammar and Government and Binding Theory presuppose derivationally related syntactic representations and the rules which map one syntactic representation into the other. LFG also deals a lot not only with English and other Indo-European languages, but also with many others, combining the functional approach with the formal rigidity of GPSG and the typological orientation of Relational Grammar.

2.6 Role and Reference Grammar

Role and Reference Grammar (RRG) was developed in the 1980s by Robert Van Valin, Jr.. It grew out of an attempt to answer two basic questions: what would linguistic theory look like if it were based on the analysis of languages with diverse structures such as Lakhota, Tagalog, Dyirbal and Barai, rather than on the analysis of English and how can the interaction of syntax, semantics and pragmatics in different grammatical systems best be captured and explained. RRG takes language to be a system of communicative social action, and accordingly, analyzing the communicative functions of grammatical structures plays a vital role in grammatical description and theory from this perspective. It is a monostratal theory, positing only one level of syntactic representation, the actual form of the sentence.

³ OBL_{θ} denotes a phrase in the oblique case, that is, a prepositional phrase

RRG rejects the standard formats for representing clause structure (grammatical relations, X-bar syntax), because they are not universal and hence necessarily impose aspects of structure on at least some languages where it is not appropriate. The RRG conception of clause structure, the ‘layered structure of the clause’ (LSC), is made up of the ‘nucleus’, which contains the predicate(s), the ‘core’, which contains the nucleus plus the argument(s) of the predicate(s), and the ‘clause’. Syntactic arguments occurring in the core are referred to as ‘core arguments’, and they may be direct or oblique. Direct core arguments are those not marked by an adposition, in languages like English and German, or those marked by direct cases (nominative, accusative, dative or ergative, absolutive, dative) in case-marking languages. Oblique core arguments are marked by adpositions or oblique cases, e.g. instrumental, locative. Modifying each level of the clause is a ‘periphery’, which contains adjunct modifiers, both phrasal (PPs or clauses, modifying the core and clause) and non-phrasal (adverbs, modifying all three layers). These aspects of the LSC are universal (Van Valin 2006).

Semantic representation of a sentence is based on the lexical representation of the verb. The verb does not contain the list of thematic roles since RRG uses the system of lexical decomposition to represent different aspects of the meaning of the verb and other predicates (Zovko 2001). The RRG theory of semantic roles is rather different from that of other theories, in that it posits two types of semantic roles. The first are specific thematic relations, the traditional notions of agent, theme, patient, experiencer, etc. The second are generalized semantic roles called ‘semantic macroroles’; they were introduced by Van Valin and have no exact analog in other theories. There are two macroroles – *Actor and Undergoer* – which represent the highest level of generalization of semantic roles. According to Van Valin and LaPolla (1997:113):

‘The participant role an entity has depends crucially on the state of affairs that the entity is involved in. (1997:85) [This role] is a function of the nature of the state of affairs, and accordingly, it is also the case that the semantic interpretation of an argument is a function of the logical structure in which it is found.’

The two macroroles group in themselves the thematic roles neutralizing in this way semantic contrast between semantic roles. This enables RRG to express better some

linguistic generalizations in the description of constructions such as passive, dative alternation etc. (Zovko 2001).

RRG takes the position that lexical entries for verbs should contain only idiosyncratic information, with as much as possible derived from general lexical principles or rules. Information about transitivity is very important, and RRG defines transitivity in terms of the number of macroroles that a verb takes (Narasimhan 1998): M[acrorole]-transitive = 2, M-intransitive = 1, M-atransitive = 0. In RRG, no syntactic subcategorization information is included in lexical entries; all of the relevant information is derivable from the logical structure of the verb plus information about its transitivity. Thus these principles have the effect of predicting the syntactic subcategorization of a verb from its semantic representation. The prepositions that mark oblique core arguments can in many instances be predicted from the logical structure of the verb and therefore need not be listed in the lexical entry (cf. Jolly 1993, Van Valin & LaPolla 1997). RRG distinguishes lexical from syntactic phenomena in terms of the linking scheme. Basically, any process which affects logical structures or the arguments therein or the mapping between logical structures and macroroles is considered to be lexical. Dative alternation (which is analyzed as variable linking to undergoer) is an example of a lexical phenomenon in RRG. Syntactic phenomena involve the mapping between macroroles and the syntactic representation, e.g. some types of passivization and antipassivization (Van Valin 2006).

If the logical structure of a verb contains two or more arguments, attribution of macroroles is done according to the co-called Actor-Undergoer Hierarchy. According to this hierarchy *a book* in the sentence

(16) John gave a book to Mary.

is predetermined for the macrorole of undergoer. However, the verb *give* allows the alternative possibility, the one that violates the given hierarchy. More specifically, *Mary* can also be an undergoer, in which case we get the sentence

(17) John gave Mary a book.

Role and Reference Grammar analyzes this as variable linking to undergoer as semantic macrorole and considers it to be the point of dative alternation. RRG does not consider traditional syntactic relations (subject, direct object, indirect object) to be universally valid and, therefore, it does not use them as theoretical analytical concepts.

Instead of this, RRG introduces only one concept of syntactic relations specific to each construction – this concept is called the privileged syntactic argument. In other words, in each construction there is a privileged argument that affects the attribution of macroroles and controls the syntactic behavior of other elements. This is why within a sentence that consists of, for example, two constructions, there can be two different privileged arguments the selection of which is affected by the hierarchy of actor.

RRG, thus, does not postulate a concept that would correspond to the direct object, since the qualities of direct objects are described under the concept of undergoer. In the same way, RRG believes that the main shared quality of all indirect objects is semantic, not morphosyntactic – they usually code the recipient of ditransitive verbs. Certain languages treat them either as direct objects or as arguments in oblique cases or they are specifically coded, which is why it is not possible to characterize them morphosyntactically in a consistent manner (Zovko 2001).

2.7 Information Structure

Another interesting theory is that of information structure. Information structure is a term first introduced by Halliday in 1967. This term usually stands for a theory which aims to explain how information is formally packaged within a sentence. As Lambrecht (1994) puts it, the structure of a sentence reflects the speaker's assumptions about the hearer's state of knowledge and consciousness at the time of the utterance. This relationship between speaker assumptions and formal sentence structure is governed by rules and conventions of grammar, in a component called information structure. However, there is still some confusion among linguists when it comes to the nature of information structure and its status within grammar in general. The problems in the study of information structure arise because grammatical analysis at this level deals with the relationship between linguistic form and the mental states of speakers and hearers. This actually means that dealing with information structure includes dealing with communicative, as well as with formal aspects of language at the same time. Despite the difficulties in the analysis of information structure which linguists encounter, all the research done so far in this field has one common idea – it is the idea that we cannot fully understand certain formal properties of a sentence if we don't look at the linguistic and extralinguistic context in which that sentence is embedded. Due to the fact that discourse includes the use of sentences in communicative settings, this kind of research is usually associated with the field of pragmatics.

We deal here with Lambrecht's ideas on information structure, which is why we concentrate more on how the speaker's hypothesis about the hearer's mental states reflects in the grammatical structure of sentences. That he is interested in this relationship between information structure and grammatical structure is clear from the title of his book – *Information Structure and Sentence Form*. Lambrecht (1994) claims that information structure is a component of grammar, more precisely, that it is a component of sentence grammar. In other words, he claims that information structure is a determining factor in the formal structuring of sentences (1994: 3). Lambrecht also proposes his definition of information structure:

'Information structure is that component of sentence grammar in which propositions as conceptual representations of states of affairs are paired with lexicogrammatical structures in accordance with the mental states of interlocutors who use and interpret these structures as units of information in given discourse contexts.' (1994: 5)

There are many important notions and terms in information structure - presupposition and assertion, identifiability and activation, topic and focus – but we do not present each of these categories in detail; rather, we only describe Lambrecht's ideas about these categories shortly. Presupposition and assertion refer to the structuring of propositions which a speaker assumes a hearer already knows or does not yet know. Identifiability and activation refer to a speaker's assumptions about the statuses of the mental representations of discourse referents in the hearer's mind at the time of the utterance. Finally, topic and focus refer to a speaker's assessment of the relative (un)predictability of the relations between propositions and their elements in given discourse situations. Among these categories, we will deal with topic and focus in more detail because this category is important for the analysis of ditransitive constructions, including dative alternation.

Lambrecht therefore concludes that information structure permeates all levels of the grammatical system that carry meaning. It is reflected in the sentence form in prosody, in special grammatical markers, in the form of syntactic constituents, in the position and ordering of those constituents in the sentence, in the form of complex grammatical constructions, and in certain choices between related lexical items. To quote Lambrecht,

‘information-structure analysis is centered on the comparison of semantically equivalent but formally and pragmatically divergent sentence pairs, such as active vs. passive, canonical vs. topicalized, canonical vs. clefted or dislocated, subject-accented vs. predicate-accented sentences etc.’ (1994: 6)

He calls these pairs of sentences allosentences, using a term first introduced by Daneš (1966). Allosentences exist because speakers do not create new structures in order to express new meanings; rather, they make use of existing structures according to what they intend to communicate. This is due to the fact that there is no one-to-one correspondence between speakers’ communicative needs or intentions and the grammatical forms of sentences. Namely, the states of affairs which a speaker can talk about are infinitive, but the grammatical structures which a language can offer to speakers are limited. This is why speakers resort to allosentences when expressing new meanings through already existing structures.

The pairs of sentences that appear in dative alternation, for example,

(18) John gave a book to Mary.

(19) John gave Mary a book.

are also allosentences because they are, as Lambrecht puts it, ‘semantically equivalent but formally and pragmatically divergent sentence pairs’. We will concentrate now on the category of topic and focus in information structure because these two notions play an important role in explaining dative alternation. In the history of information structure the concept of *topic* has been identified with that of *theme* as referring to the element which comes first in the sentence and expresses what is being talked about. It is also sometimes considered *old* or *given information*. Lambrecht dismisses this definition since he claims that the element that comes first in a sentence does not necessarily need to be topic, it can be focus, too. His definition of topic is related to the definition of subject in traditional grammar, that is, the topic of a sentence is the thing which the proposition expressed by the sentence is about. Even though this definition is derived from the traditional definition of subject, Lambrecht emphasizes that topics need not always be grammatical subjects and vice versa. Focus, on the other hand, has usually been identified as *comment*, or the element which expresses what is being said about the topic. It is also sometimes considered as *new information*. Lambrecht

says that the focus of a sentence, or the focus of the proposition expressed by a sentence, is the element of information which cannot be taken for granted at the time of speech – ‘it is the unpredictable or pragmatically non-recoverable element in an utterance. The focus is what makes an utterance into an assertion’ (1994:207). Lambrecht’s concept of focus is similar to that used by Halliday (1967), Chomsky (1965) and Jackendoff (1972), this is especially obvious when we consider Halliday’s definition of focus:

‘Information focus is one kind of emphasis, that whereby the speaker marks out a part (which may be the whole) of a message block as that which he wishes to be interpreted as informative. What is focal is “new” information; not in the sense that it cannot have been previously mentioned, although it is often the case that it has not been, but in the sense that the speaker presents it as not being recoverable from the preceding discourse...The focus of the message, it is suggested, is that which is represented by the speaker as being new, textually (and situationally) non-derivable information.’ (1967: 204)

When it comes to dative alternation, the principles of end-focus and end-weight also play an important role. If we look at the sentence,

(20) John gave a book to Mary.

in this case, *to Mary* is the information that is the newest; it is ‘the unpredictable or pragmatically non-recoverable element’ of the sentence. What is focused here is the recipient role, which appears later in the sentence than the already known element, that is, the theme role. In other words, *to Mary* is focused here because the presupposition is that the hearer already knows that John gave a book to someone – what the hearer does not know is that he gave it precisely to Mary. By analogy, in the sentence

(21) John gave Mary a book.

non-derivable information is the semantic role of theme, in our case *a book*. The theme is focused here because the presupposition in this sentence is that the hearer already knows that John gave something to Mary, but he doesn’t know that it was a book. However, there are also some constraints on structures that undergo dative alternation in terms of the relationship between information structure and sentence form. For example, according to the end-focus

principle, if the recipient role is a pronoun, alternated construction is preferred because pronouns refer to something that has been mentioned before, that is, they have a referent who is supposed to be known to the hearer. Therefore, the focused element is the theme which comes at the end. Also, according to the principle of end-weight, heavy themes have to appear in sentence-final position, that is, the focus has to be on themes if they are heavy NPs.

2.8 Goldberg's Construction Grammar

The last theory we will present before moving to Cognitive Grammar is Adele Goldberg's Construction Grammar. More specifically, we will present her approach to argument structure, which is especially important for us with respect to ditransitive constructions. Since Construction Grammar is in many ways related to cognitive linguistics, we chose to present this theory last to mark the transition between earlier theories and the theory of Cognitive Grammar that we will adopt in this paper.

Construction Grammar was developed in the 1980s, primarily by Charles Fillmore, Paul Kay and George Lakoff, although some of its ideas go back to Generative Semantics. The basic principle of Construction Grammar is that traditional constructions – that is form-meaning correspondences – are the basic units of language. It also claims that there is no strict division between the lexicon and syntax; lexical and syntactic constructions differ in their internal complexity, but they both pair form with meaning. This is not to say that there are no any distinct morphological or syntactic constructions – Construction Grammar simply claims that there are cases between these two types of constructions that make the boundary between them blurry. Construction Grammar also states that there is no strict boundary between semantics and pragmatics – information about focused constituents, topicality and register is present in constructions as well as semantic information. It could be said that Construction Grammar is generative because it tries to account for the infinite number of expressions which the grammar allows, at the same time trying to account for the fact that an infinite number of other expressions is disallowed. Construction Grammar is not transformational because it does not postulate any underlying syntactic or semantic forms. Rather, it is a monostratal theory, just like Lexical Functional Grammar, Role and Reference Grammar, Generalized Phrase Structure Grammar and, finally, Cognitive Grammar (Goldberg 1995).

In her book *Constructions: A Construction Grammar Approach to Argument Structure* (1995), Goldberg studies basic sentence types, or, as she says, 'the simple sentences of traditional grammarians'. She claims that basic English sentences are instances of

constructions, that is, form-meaning correspondences which exist independently of particular verbs. In other words, she argues that constructions themselves carry meaning, independently of the words in the sentence. Goldberg (1995) does not say that individual lexical items carry no information, but she claims that an approach based entirely on lexicon cannot account for the full range of English data, or in other words

‘Particular semantic structures together with their associated formal expression must be recognized as constructions independent of the lexical items which instantiate them’ (Goldberg 1995:1).

As Goldberg states, it has been known for a long time that differences in complement configuration are usually connected with differences in meaning. Many linguists have shown that there are systematic differences in meaning between sentences with the same lexical items in slightly different constructions and it has even been claimed that ‘a difference in syntactic form always spells a difference in meaning’ (Bolinger 1968:127). In her approach, Goldberg claims that argument structure constructions are a special subclass of constructions that provides the basic means of clausal expressions in a language. She analyses five types of English constructions – ditransitive, caused motion, resultative, intransitive motion and conative. These constructions are associated with dynamic scenes – experientially grounded gestalts, such as that of someone volitionally transferring something to someone else, someone causing something to move or change state, someone experiencing something, something moving, and so on. In her approach, systematic differences in meaning between the same verb in different constructions are attributed directly to the particular construction.

Given the topic of our paper, we are primarily concerned with her analysis of ditransitive constructions.

In the constructional approach, aspects of the interpretation involving caused motion, intended transfer or caused result are understood to be contributed by the respective constructions. In other words, skeletal argument structure constructions are capable of contributing arguments. For example, the ditransitive construction is directly associated with agent, patient and recipient roles – it usually involves transfer between a volitional agent and a willing recipient, just like in our examples

(22) John gave Mary a book.

where *John* is a volitional agent, *Mary* a willing recipient, and the thing being transferred (patient) *a book*. Ditransitive constructions are specific (syntactically) because they allow two nonpredicative noun phrases to appear directly after the verb – the fact that English allows this kind of configuration cannot be predicted from other constructions in the language. Also, ditransitive construction is the only one that links the recipient role with the grammatical function of object (Goldberg 1995).

When it comes to the nature of constructional meaning, Goldberg emphasizes the notion of polysemy.

‘Constructions are typically associated with a family of closely related senses rather than a single, fixed abstract sense. Given the fact that no strict division between syntax and the lexicon is assumed, this polysemy is expected’ (1995:31).

For example, it is considered that in ditransitive constructions agent acts volitionally to cause transfer of an object to a recipient – it is argued that this kind of actual successful transfer is the basic sense of ditransitive construction. However, there are many ditransitive constructions which do not imply that the patient is successfully transferred to the recipient. Goldberg gives the following example:

(23) Sally baked her sister a cake.

in this case, we cannot claim that the transfer was successful – we only know that it was intended, that is, we know that Sally baked a cake with the intention of giving it to her sister, but whether she actually gave it to her remains unknown. When it comes to this example, if we do not associate the ‘intended transfer’ aspect of meaning to the construction, we are forced to say that the verb *bake* in itself means something like ‘X intends to cause Y to receive Z by baking’, which is the case with lexically based approaches to grammar.

There are many other ditransitive constructions which involve cases different from its basic sense, that is, many other cases in which the transfer is not actual and successful. This is why Goldberg claims that the semantics involved in all these different cases is best represented as a category of related meanings. In other words, she proposes that the ditransitive construction is associated with a set of systematically related senses which is why we can consider it as a case of constructional polysemy, as opposed to postulating a set of lexical rules. Goldberg also presents different semantic constraints and metaphorical extensions on dative constructions which we will not enumerate here.

Goldberg's approach to argument structure postulates that

'... an entirely lexically based approach to grammar is inadequate, and that lexically unfilled constructions must be recognized to exist independently of the particular lexical items which instantiate them' (1995: 224).

Because it posits the existence of meaningful constructions, Goldberg's approach manages to avoid the claim that syntax and semantics of the clause are projected only from the specifications of the main verb. Therefore, her construction approach to argument structure manages to avoid many problems of previous approaches, such as positing implausible verb senses to account for exceptional examples (as was the case with the verb *bake* in the example 23).

3. Cognitive Grammar

3.1 Towards Cognitive Grammar

So far we have presented several syntactic theories dealing with English ditransitive constructions and dative alternation. Now we will proceed to address the issue from the point of view of Cognitive Grammar, which is the approach we adopt in our analysis of ditransitive constructions and dative alternation. The reason why we chose precisely the theoretical framework of Cognitive Grammar to deal with this issue is because we believe that its ideas provide the most consistent overall account of these phenomena. However, before we move on to the analysis of ditransitive constructions, we will try to explain briefly how Cognitive Grammar is different from other theories in this respect.

Generative theories regarded ditransitive constructions as being derived from one another – most of these theories considered the prepositional construction

(24) John gave a book to Mary.

to be the deep structure from which the alternative sentence was derived. This was the opinion introduced by Fillmore (1968:30) since he believed that all the various categorically

introduced noun phrase types begin with a preposition; however, his view holds only for obligatory arguments. There were also some linguist who disagreed with the opinion that the prepositional construction was the deep structure, primarily Dryer (1986). Later on, linguist became interested in whether transformations changed grammatical relations – we have seen how this issue was dealt with by Relational Grammar in previous chapters (grammatical primitives and 3-to-2 advancement). Step by step, traditional direct and indirect objects were replaced by the notions of *primary* and *secondary* objects – the terms advocated by Dryer who also adopts transformational approach, but claims that double object constructions

(25) John gave Mary a book.

are more basic than paraphrases with *to* (Szabone 2003). This claim by Dryer served as an argument to support his idea about the existence of two grammatical relations - *Primary Object* (PO) and *Secondary Object* (SO) – that were first suggested by Perlmutter and Postal (1984). The PO is the equivalent of the direct object of transitive clauses and it is the first object in ditransitive clauses. By analogy, the SO is the second object in ditransitive clauses. Dryer explains the existence of these categories through what he calls the ‘Natural Class Principle’. This principle states that if many languages have rules that apply specifically to a certain form this form should be considered a natural class. Given that object marking and passive are sensitive to the PO in many languages, the Natural Class Principle implies that the PO exists as a natural class. However, the argument as to whether the categories of the PO and SO exist in English does not affect the question whether double object construction is base generated, as Dryer claims, or derived (Goldberg 1995).

Various formalist and functionalist approaches preceding Cognitive Grammar also dealt with these phenomena. What they all have in common is that they see language as a self-contained system. The properties of this system are contained in grammar, which is a device that generates or defines the set of well-formed sentences which constitute the language. In other words, formalist approaches consider language to be a disembodied object, independent of the speakers who use it and the purposes they use it for (Taylor 2002). On the other hand, functional approaches question the autonomy of language; they emphasize communicational aspect of language and aim to describe both language competences of the speaker, and what the speaker knows about using language in different communicational situations. To quote Dik (1991):

'The language system, therefore, is not considered as an autonomous set of rules and principles, the uses of which can only be considered in a secondary phase; rather it is assumed that the rules and principles composing the language system can only be adequately understood when they are analyzed in terms of conditions of use.' (1991: 247)

Cognitive Grammar is offered as an alternative to the generative tradition and rejects many of its underlying assumptions; however, there are some parallels between Cognitive Grammar and various versions of generative theories, as well as some theories of functional approach. For example, Cognitive Grammar shares with Generative Semantics a concern for dealing explicitly with meaning and for providing a unified account of grammar and lexicon. With GPSG, Cognitive Grammar shares the idea of dismissing transformational derivations altogether. In some instances, Cognitive Grammar is similar to Bresnan's (1982) LFG (especially when it comes to the emphasis on lexicon) and it also resembles Jackendoff's (1977) X-bar syntax (in that it uses schemas to capture cross-category generalizations) (Langacker 1987). However, Cognitive Grammar shares most characteristics with Construction Grammar. Both theories claim that constructions are separate entities within grammar which have their own syntactic, semantic and pragmatic features and that they are form-meaning pairings that cannot be strictly predicted from knowing the rest of the grammar. Another claim they have in common is that simple clause constructions are directly related to semantic structures which reflect scenes basic to human experience – we can view the construction as imposing a certain semantic construal on the scene described (Szabone 2003).

3.2. Cognitive Grammar

'Grammar (or syntax) does not constitute an autonomous formal level of representation. Instead, grammar is symbolic in nature, consisting in the conventional symbolization of semantic structure' (Langacker 1987:2).

This claim by Ronald Langacker represents one of the basic notions of Cognitive Grammar. It is related to the general claim of Cognitive Grammar about the nature of language, that is, that language is symbolic in nature. It enables the speaker to use for communication an open-ended set of linguistic signs or expressions. Each of these expressions consists of a semantic representation of some kind that is in symbolic relation

with a phonological representation. The central position of meaning in Cognitive Grammar is the result of the symbolic nature of language. Cognitive Grammar also claims that semantic structure is not universal: rather, it is, to a considerable degree, language-specific. Semantic structure is based on conventional imagery and it is characterized relative to knowledge structure. Finally, the last important claim of Cognitive Grammar is that there is no meaningful distinction between grammar and lexicon. Lexicon, morphology and syntax form a continuum of symbolic structures which differ along various parameters but can be divided into separate components only arbitrarily (Langacker 1987).

Unlike many other views of language, Cognitive Grammar claims that it is not a separate faculty, but a part of our overall cognitive abilities. In other words, it is an integral part of human cognition. Grammar is not just a set of formal rules; it is the solution that speakers have found to structure their thoughts in order to communicate them to other people. As products of speakers, the words and grammatical structures reflect their physical, psychological and social experiences.

'The distinctions made by the lexicon of a language reflect important specific experiences of our lives, while the distinctions made by its grammar reflect recurrent and generalized experiences. Like the words of a language, the grammar of a language is meaningful, too' (Radden and Dirven 2007:11)

One of the things Cognitive Grammar wishes to achieve is to discover the motivation that underlies grammatical structures. According to Radden and Dirven's (2007) account of Cognitive Grammar,

'The main functions of language are to enable people to symbolize their experiences in a perceptible form and to communicate them to others. In expressing their thoughts, speakers constantly need to decide which words and grammatical constructions to use. Both the inventories of words and constructions of a language provide a set of options which the speaker has to choose from in communicating her thoughts. A cognitive approach to grammar is therefore "usage-based": it looks at the structural choices available and the speaker's reasons for choosing one alternative over the other.' (Radden and Dirven 2007:11)

The idea that the words and grammatical structures we use reflect our physical, psychological and social experiences, that the way in which we perceive the world around us determines our

choice of grammatical structures is central to our analysis of ditransitive constructions and dative alternation. In Langacker's (1987) view, Cognitive Grammar claims that

'Grammar itself serves an 'imagic' function and that much of it has a figurative character. Grammar (like lexicon) embodies conventional imagery. By this I mean that it structures a scene in a particular way for purposes of linguistic expression, emphasizing certain facets of it at the expense of others, viewing it from a certain perspective, or construing it in terms of a certain metaphor. Two roughly synonymous sentences with the same content words but different grammatical structures – including, in particular, sentences generally analyzed as being transformationally related – are claimed instead to be semantically distinct by virtue of their different grammatical organization per se.' (1987: 39)

What this actually means for ditransitive constructions and dative alternation is that both sentences

(26) John gave a book to Mary.

(27) John gave Mary a book.

describe the same event and can be interchanged, but they differ semantically. In other words, the difference between these two constructions is in that they represent different cognitive construals of the same event (Langacker 1987.) For example, the first sentence focuses on the transfer of the object, *a book*, which is indicated by the preposition *to*, which usually has a spatial-directional meaning. The second, alternated sentence, focuses on the recipient, *Mary*, which is expressed as an indirect object (Radden and Dirven 2007). In Langacker's words, the first sentence emphasizes the path traversed by a book with Mary as goal, whereas the second sentence emphasizes the resulting state in which Mary possesses the book. He does not claim that the notion of path is lacking in (27), nor that the notion of possession is lacking in (26) – both are present to some degree in each sentence. However, the relative salience of these two notions differs in the two sentences; the differences in grammatical structure emphasize one facet of the conceived situation at the expense of another. In other words, the two sentences present the scene through different images (Langacker 1987: 39).

In order to present in more detail the view of Cognitive Grammar on how we choose grammatical structures to express our thoughts, that is, on the relationship between events in our mind and linguistic expressions of those events, we resort to Radden and Dirven's account

of the relationship between event schemas and sentence patterns. We focus mainly on the transfer schema and the corresponding ditransitive construction, but first a short overview of some basic linguistic terms related to this issue, such as conceptual core, thematic roles and event schemas, is in need. A conceptual core can be defined as a relation combined with two or more conceptual entities participating in it. Those conceptual entities hold unique functions within a given situation – these functions are called thematic roles (sometimes also semantic roles or case roles). The conceptually prominent roles, which are typically associated with the conceptual core of a situation, are known as participant roles. The most important participant roles are those of an agent, a theme, a cause and an experiencer, whereas less central participant roles are those of location and possessor. There are also some thematic roles that are not part of the conceptual core of a situation. They are called non-participant roles and usually serve to specify the setting of a situation. The configuration of thematic roles determines the schematic meaning of a situation – such configurations of roles are known as event schemas. The set of event schemas includes the emotion schema, the action schema and the transfer schema. Event schemas are expressed in language by the grammatical constructions characterizing basic clauses and sentences. These constructions are known as sentence patterns. There are seven basic sentence patterns in English, but we will deal only with the ditransitive pattern. These sentence patterns form the ‘linguistic grid’ available for expressing event schemas, but we have to bear in mind that there is no one-to-one correspondence between event schemas and sentence patterns. In other words, not every event schema is matched with a sentence pattern of its own and the seven basic sentence patterns make different distinctions from those made by the event schemas. However, the relationship between event schemas and sentence patterns is not completely arbitrary. According to Radden and Dirven (2007), event schemas can be subsumed under three “worlds of experience”: the material world, the psychological world and the force-dynamic world.

‘The material world is understood as the structured world of entities as they exist, change, or undergo processes. The material world also includes humans who do not take an active part in shaping it. The psychological world is the internal world of people’s sensations, emotions, perceptions and thoughts. It is the world as experienced and conceptualized by sentient humans. The force dynamic world is the external world of action, force and cause and their effects. In this world, human agents figure prominently as the instigators of events. It goes without saying that these three worlds of experience are far from clear-cut; they tend to overlap and are much more likely to be understood in a prototypical sense’ (Radden, Dirven 2007:272).

Given the topic of our paper, we will focus on the force-dynamic world and within it the transfer schema, which is expressed linguistically by ditransitive constructions.

3.3 Ditransitive constructions in Cognitive Grammar

As put by Radden and Dirven (2007), the transfer schema describes events in which an agent passes a thing to a recipient. Acts of transfer are often accompanied by a change of possession: the agent gives up her ownership of a thing and transfers it to the recipient, who becomes the new owner. This complex situation can often be expressed in two ways: as a ditransitive construction as in

(28) Phil gave his wife everything.

or as a caused-motion construction as in

(29) Phil gave everything to his wife.

‘It is usually considered that both sentences have the same meaning. This is due to the fact that a prototypical act of giving involves both the transfer of a physical and its change of ownership. The ‘giving’ frame thus neutralizes potential differences in meaning which may arise through using different constructions’ (Radden, Dirven 2007:294).

Although both sentences are usually said to have the same meaning, the difference between them lies in focus. In the first sentence, we focus on the recipient which is expressed as an indirect object, whereas in the second sentence our focus is on the transfer of the object, which is indicated by the preposition *to* in the prepositional phrase *to his wife*. Since these two constructions are obviously interchangeable, they are usually treated as structural alternations and are known as dative alternation or dative shift.

Nevertheless, we have to bear in mind that not all situations of transfer, for example situations of abstract transfer, can be expressed in alternative ways. This brings us to the fact that we can differentiate between various kinds of transfer, namely, physical, abstract, beneficial and metaphorical transfer. We will not describe the authors’ presentation of each of the four types of transfer because it is quite detailed; these different types of transfer will be mentioned later on in the analysis of the results of the research we conducted. The important thing to remember about these types of transfer is that they differ in whether they allow both transitive and caused-motion construction, which, once again, depends on the meaning we wish to convey or the aspect of the transfer we wish to focus on. So far we have presented only a

general overview of Cognitive Grammar and the question of dative alternation; more detailed account of how Cognitive Grammar explains dative alternation and various examples will be provided in the following chapters where we will present the results of our research⁴.

4. Ditransitive constructions and dative alternation in Croatian

As we have already mentioned in the introduction, we will also present the issue of ditransitive constructions and dative alternation in Croatian, although our primary concern was English. First we will give a theoretical background of this issue in Croatian and then we will try to support our claim that Cognitive Grammar is the best theory to explain the phenomena with the results of our research. As already stated, unlike English, Croatian is a case-marking language. Case-marking languages rarely exhibit dative alternation, but Croatian allows this construction with several verbs, which only supports the claim that constructions like dative alternation are semantically, that is, pragmatically motivated. Namely, in case-marking languages, including Croatian, the relation between the predicate and its arguments is coded by cases which is why the change of position of the elements in a sentence does not usually result in the change of syntactic relations; however, dative alternation is an exception to this rule (Zovko 2001).

Croatian exhibits dative alternation with three verbs, eight if we include their aspectual counterparts. Those verbs are: *darivati*, *darovati*, *podariti*, *nuditi*, *ponuditi*, *služiti*, *poslužiti* and *posluživati*. In our research we also included the verb *donirati* which is beginning to appear in dative alternation more often, although we would not yet include it in the list of Croatian verbs that exhibit dative alternation. A typical example of Croatian sentences that undergo dative alternation would be

(30) Ivan je Mariji darovao knjigu.

(31) Ivan je Mariju darovao knjigom.

In the sentence (30), *Mariji* is an indirect object in the dative case and it carries the semantic role of recipient, whereas *knjigu* is a direct object in the accusative carrying the role of patient. In the sentence (31), there was a change in the syntactic relations and *Mariju* became the direct object in the accusative, whereas *knjigom* became the indirect object in an oblique case, namely in the instrumental. As typical of dative alternation, both sentences describe a situation of transfer of a patient (theme) argument between an agent and a recipient and the semantic roles of the arguments have not changed regardless of the change in syntactic

relations. We believe that this advancement of indirect objects into direct ones reflects the speakers' wish to add focus to the recipient and/or emphasize either the process of transfer or the result of that transfer.

Dative alternation in Croatian has been a matter of interest of the researchers, although additional research is needed given the fact that it is a rare phenomenon in case-marking languages such as Croatian. We will base our research of ditransitive constructions in Croatian on the work of Zovko (2001) and Zovko Dinković (2007). We believe that these works have contributed a lot to the study of dative alternation in Croatian and many results of those studies are very useful for our research, too. However, Zovko Dinković (2007) based her analysis on the Role and Reference Grammar, whereas we try to approach it from the Cognitive Grammar point of view. Many examples of sentences we used in our research are taken directly from Zovko (2001) and Zovko Dinković (2007); however, the time span of six and twelve years respectively between our paper and those of Zovko Dinković provides wide enough a period for us to analyze whether the views of Croatian speakers regarding sentences that undergo dative alternation have changed and in what ways. We provide examples and explanations of ditransitive constructions and dative alternation in Croatian in the following chapters where we present the results of our research and compare them to those of Zovko Dinković (2007).

5. Research

In order to support our claim that the phenomenon of dative alternation in ditransitive constructions is best explained precisely by cognitive grammar we devised and conducted a research on speakers of both English and Croatian. Our aim was to see:

- 1) whether the speakers prefer canonical or alternated constructions
- 2) how acceptable some sentences with different types of objects are to them, and
- 3) whether they perceive any difference in meaning between the two constructions.

Since we conducted this research on both speakers of English and Croatian, we devised two similar, but slightly different types of questionnaires since the verbs that allow dative alternation are not the same in English and Croatian. We were also interested in the types of explanations that the speakers used in order to explain their choices because they have provided us with useful insights into how the speakers construe the situations expressed by

two (syntactically) different ways in their minds. Since there were five groups of participants, some native speakers of either English or Croatian, others both native speakers and students of given languages, we expected the native speakers to rely more on their intuition when giving explanations, and the students to provide more ‘grammatical’ explanations. We also wanted to see whether the (English) speakers’ explanations will be in line with the explanations provided by Cognitive Grammar, that is, whether those speakers will also take into consideration semantics, pragmatics, experience and knowledge of the world.

5.1. Participants

Four groups of speakers participated in the research: one group of native speakers of English, one group of students of English, one group of native speakers of Croatian and one group of students of Croatian. However, the (Croatian) students of English were provided with both questionnaires, in English as well as in Croatian, so that we actually collected five sets of data – two groups filled in the questionnaire in English, whereas three groups filled in the questionnaire in Croatian. The first group are 15 native speakers of English – their age ranges from 17 to 66 (31.2 on average) and their level of education from 1st year of high school to Ph.D. The second group are native speakers of Croatian who are at the same time students of English. There are 20 of them and they all attend Faculty of Humanities and Social Sciences in Zagreb (4th and 5th year students of English). They are between 22 and 30 years old (23,95 on average) and they have been studying English for 16 years on average (from 9 to 24). As already mentioned, this group filled in both types of questionnaires since they speak both Croatian and English. The third group are 15 native speakers of Croatian⁴ between 18 and 69 years (32.07 on average). Their level of education ranges from elementary school to master’s degree. They come from different parts of Croatia; however, only one speaker comes from the seaside, all the others are from the continental part of the country⁵. The last, fourth group of speakers are 15 native speakers of Croatian who are at the same time students of Croatian or they have already graduated in Croatian. Their age range is between 22 and 29

⁴ It is important to note that none of them are studying any language so we expected them to base their answers on their native speaker intuition rather than on any specific linguistic knowledge

⁵ We asked the native speakers of Croatian to state the place where they have spent most of their life; however, the place of residence did not prove to be of any importance for our research

(24.5 on average) and their level of education ranges from BA to MA⁶. Participation in the research was voluntary and anonymous.

5.2. Methods

The participants were presented with two types of questionnaires. Two groups filled in the questionnaire in English (native speakers of English and Croatian students of English), whereas three groups filled in the questionnaire in Croatian (native speakers of Croatian, Croatian students of English and Croatian students of Croatian). Both questionnaires had similar types of questions; however, the Croatian one was somewhat longer and contained more questions.⁷ Examples of both types of questionnaires are presented in Appendix 1.

The questionnaire in English had four types of questions. In the first question, the participants were asked to circle the construction they would prefer in everyday communication and briefly explain their choice. This question contained five pairs of sentences and we wanted to see if they preferred the canonical ditransitive construction or the alternated one⁸. The second question had a list of 15 sentences with mixed canonical and alternated constructions of the same sentences. The sentences in this question were examples of both prototypical acts of transfer between a volitional agent and a willing recipient as well as examples of beneficial and metaphorical transfer with different types of object arguments. The participants were asked to circle on the scale from 1 to 5 how acceptable each sentence was for them because we wanted to see how they perceived the sentences which do not involve a prototypical act of transfer⁹. The third question had a list of eight sentences: four expressing a beneficiary as an indirect object in the alternated construction and four expressing metaphorical transfer with the verb *give*, also in the alternated construction¹⁰. The participants were asked to circle the sentences they found most acceptable from the list since

⁶ We asked this group whether they were bilingual (English/Croatian) and 3 out of 15 students said yes; however, their bilingualism also proved not to affect their answers in the Croatian questionnaire

⁷ This is due to the fact that in the Croatian questionnaire we also wanted to research some semantic constraints on dative verbs (such as those of serving and offering), acceptability of certain sentences in which one argument was left out, aspectual differences, passive forms, and the choice between different types of objects (animate/inanimate; partitive/whole)

⁸ The examples were taken from Radden and Dirven (2007:294) and Taylor (2002:426-427)

⁹ The examples for this question were taken from Radden and Dirven (2007: 296-299) and Taylor (2002:426)

¹⁰ All the examples in this question were taken from Radden and Dirven (2007: 296-297)

we wanted to see how acceptable sentences with non-prototypical types of beneficial situations¹¹ and those involving metaphorical transfer are to them. The last, fourth, question consisted of four pairs of sentences with both canonical and alternated construction and the participants were asked whether they felt there was any difference in meaning between the two constructions¹². Our aim was to see (if the speakers felt there was indeed a difference in meaning between the two constructions) what explanations they would provide for their answers and whether those explanations would comply with those provided by Cognitive Grammar.

As mentioned above, the questionnaire in Croatian was somewhat longer and more detailed. It had five different questions, with the fifth one containing three separate subsets of questions. In the first question, the participants were given five pairs of sentences with both canonical and alternated construction and asked to circle the one that sounded more natural to them and briefly explain why¹³. We wanted to see whether the speakers of Croatian preferred canonical construction with the direct object in the accusative case and the indirect one in an oblique case (usually dative) or the alternated one with indirect object becoming the direct one and behaving in such a way¹⁴. The second question contained a set of 15 sentences with different types of objects (animate/inanimate, heavy NPs with different word order) and ditransitive verbs (aspectual counterparts)¹⁵. The participants were asked to circle on the scale from one to five how acceptable each sentence was to them. In this way we wanted to see whether the speakers preferred canonical or alternated constructions, sentences with heavy

¹¹ We took over the examples for this question from Radden and Dirven (2007: 296) who quote a study by Allerton (1978) that asked speakers of English to rate the acceptability of sentences with a beneficiary as an indirect object

¹² The examples for this question were either taken from Radden and Dirven (2007) or our own

¹³ The examples in this question were either based on those in Zovko Dinković (2007) or taken from the Croatian National Corpus

¹⁴ Since Croatian is a case-marking language, it is relatively easy to explain dative alternation in terms of syntax – in canonical constructions, direct objects are in the accusative case and indirect objects appear in one of the oblique cases (most often the dative case, but also genitive, locative and instrumental). In alternated constructions, indirect objects of some verbs can become direct objects and behave as such, which means that they now appear in the accusative case and can become subjects of the corresponding passive sentences. Former direct objects become indirect ones in the alternated construction and receive the instrumental case. This is purely syntactical explanation of dative alternation in Croatian. However, just like in English, we also need to take into account semantics and pragmatics in order to explain the existence of this phenomenon in Croatian since it is very rare in any case-marking language (Zovko Dinković 2007).

¹⁵ The examples for this question were either taken from Zovko Dinković (2007) or our own

NPs as recipients at the end of the sentence or right after the verb, animate or inanimate arguments, actual transfer or metaphorical one etc. The third question had a list of eight sentences: four of them had a heavy NP as the theme argument in both canonical and alternated construction and we wanted to test which word order was most acceptable for the speakers – heavy NP at the end of the sentence or right after the verb. The other four sentences all had the same verb – *ponuditi* (to offer) – in the alternated construction with different theme arguments since we wanted to check if Croatian speakers still dismiss theme arguments that do not refer to food or beverage with the verb *ponuditi*¹⁶ as this is one of the semantic constraints on theme arguments of the verb ‘to offer’ in Croatian. The participants were asked to circle the sentences they found most acceptable among the eight given sentences. The fourth question had four pairs of sentences and the participants had to say whether they felt any difference in meaning between the canonical construction and the alternated one and explain, if it existed, what the difference was¹⁷. We wanted to see whether the speakers will perceive the difference in meaning in the alternated construction due to the semantic constraint on the theme arguments that involve the verb *ponuditi* (offer to eat/drink or offer to buy/take away)¹⁸ as well as whether they will perceive the difference in meaning between the two types of construction with regard to the successfulness of transfer¹⁹. The first subset of questions in the fifth task asked the participants once again to choose the more acceptable sentence in a pair; however, the only difference here was in the aspect of the verb as we wanted to see whether the speakers prefer perfective or imperfective verbs. The second subset of questions contained the sentences in which one argument was omitted, either the recipient or the theme argument and we asked the participants to state whether these sentences were acceptable to them or not and explain their answers. The last subset of questions had pairs of passive sentences with both perfective and imperfective verbs and we wanted to

¹⁶ Zovko Dinković (2007) analyzed the same examples and we wanted to see whether the speakers' perception has changed during the period of six years between her analysis and ours

¹⁷ The examples for this question were taken from Zovko Dinković (2007)

¹⁸ Zovko Dinković (2007) also dealt with this issue concluding that if the theme arguments of the verb *ponuditi* refer to a single entity, then only the alternated construction conveys the meaning ‘offer to eat/drink’, whereas canonical dative constructions in this case are more likely to convey a different meaning, such as ‘offer to buy/take away’ (18).

¹⁹ See also Zovko Dinković (2007:12)

check whether there was any difference in meaning between the two sentences in a pair, as well as which one was more acceptable and/or natural for the speakers²⁰.

There was no time limit for the speakers to fill in either of the questionnaires, and the average time they needed was 15 minutes. However, as expected, the Croatian questionnaire took longer time to fill in due to a larger number of questions and examples (on average 25 min).

5.3 Results and discussion

5.3.1 Native speakers of English

As we expected, native speakers of English relied more on their intuition when explaining their choices, rather than providing any (strictly speaking) grammatical explanations. They all used explanations such as ‘it sounds more natural’, ‘it’s shorter, more straightforward, the meaning is clearer’ or ‘it sounds bad/awful’ and ‘it doesn’t sound right’. In the first question, the speakers preferred the alternated constructions in examples with prototypical acts of transfer and beneficial transfer (e.g. *I’ll mail you the report; Phil gave his wife a big hug; Do your old friend a favor.*), and most of them said that the choice depended on what you wished to emphasize – however, it was interesting to see that, for example, in the first pair of sentences

(32) I’ll mail you the report.

(33) I’ll mail the report to you.

14 out of 15 speakers preferred (32), but their opinions differed with regard to what was emphasized in that sentence. Some said the emphasis was on the recipient, *you* (which would be in accordance with Cognitive Grammar point of view), whereas others said the emphasis was on the report (which would be more in accordance with Information Structure theory). As we expected, native speakers recognized the sentences such as *I’ll donate the charity \$50* and *He announced the delegates his decision* as sounding wrong, choosing the canonical form as the preferred one. However, only 3, that is, 8 speakers respectively found the alternated constructions of these examples ungrammatical. As Taylor (2002) said, with the verb *donate* the focus is on the giving of money, not the benefit of the institution and the speakers said the

²⁰ All the examples in question five were based on Zovko Dinković (2007)

same claiming that it is more important what you are donating than who you are donating it to. The verb *announce*, in Taylor's words, specifically profiles the making public of some information, and only secondarily the informing of an audience (2002:427). All the speakers recognized the alternated construction in this example as wrong or unclear in meaning and chose the canonical construction, but not all of them said it was ungrammatical. Some said that the decision is more important than who you are announcing it to, and some that you are supposed to announce your decision, not the delegates. The most interesting explanation we found was the one saying that 'this is a formal situation and it requires correct English', which means that the speaker took into account pragmatics and their knowledge of the world, relating the act of announcing a decision to some formal event, which is usually the case in everyday life.

The second question was the set of 15 sentences whose acceptability the speakers had to rate on the scale from 1 to 5. The overall quantitative results for this question are presented in Table 1. As we expected, the most acceptable sentences were cases of beneficial transfer in which an agent creates a thing for a beneficiary, as stated by Radden and Dirven (2007:296). Here, the alternated construction was preferred: *I'll bake you a cake, Honey, could you please fix me a hamburger?, He played us a wonderful sonata*. Non-creative actions proved to be preferred with the prepositional construction (*Could you fix my drawer for me?*) which is again in accordance with the explanations provided by Radden and Dirven (2007).

In the third question, the speakers were asked to choose the most acceptable sentences from the list of eight sentences; four of them had a beneficiary as an indirect object in the alternated construction and four expressed metaphorical transfer with the verb *give*, also in the alternated construction. The most acceptable sentences proved to be those expressing metaphorical transfer (*He gave me an idea* and *He gave me a look*, both chosen by 86% of speakers). This is not surprising since the transfer schema is a source domain for many metaphorical extensions, especially when it comes to human interaction. According to Cognitive Grammar, these metaphors are based on our understanding of events and states as (reified) things that can be possessed. In other words, since I 'have' an idea, I can also 'give' it to someone else. However, while things/object are physically transferred and no longer belong to the giver, ideas that we give to someone else remain with us, too (Radden and Dirven 2007: 297). The other four sentences on the list were examples of beneficial transfer with a beneficiary as an indirect object. The examples were taken over from Allerton (1978), quoted in Radden and Dirven (2007), and we found that the only sentence out of these four

chosen by native speakers was the one in which an agent creates a thing for a beneficiary, that is, in which there is some sort of creative act, for example, *Could you cook me a meal?* (66% of the speakers), whereas the other three sentences were not chosen by anyone.

Sentence	NA	AP	RA	A	CA	AM
a) The dressmaker designed me a lovely dress.	0	3	7	2	3	3,3
b) I'll bake you a cake.	0	0	0	4	11	4,7
c) Jennifer sent David's office a bunch of flowers.	2	2	3	4	4	4,7
d) He played us a wonderful sonata.	0	1	3	4	7	4,1
e) Honey, could you please fix me a hamburger?	2	0	5	3	5	3,6
f) He gave a fright to me.	10	5	0	0	0	1,3
g) I'll bake a cake for you.	0	0	2	2	11	4,6
h) Jennifer sent a bunch of flowers to David's office.	0	0	0	3	12	4,8
i) The dressmaker shortened me the dress.	11	3	0	0	1	1,5
j) Could you fix me my drawer?	12	3	0	0	0	1,2
k) Honey, could you please fix a hamburger for me?	4	1	1	3	6	3,4
l) He played us the piano.	6	4	2	2	1	2,2
m) He gave me a fright.	2	0	1	4	8	4,1
n) Could you fix my drawer for me?	0	0	2	2	11	4,6

NA – not acceptable; AP – awkward, but possible; RP – relatively possible; A – acceptable; CA – completely acceptable; AM – average mean

Table 1. Native speakers of English rating the acceptability of ditransitive constructions

In the last, fourth question, the participants were asked whether there was any difference in meaning between the canonical and the alternated construction of four pairs of sentences. An interesting example were sentences

(34) Professor White taught me Cognitive Grammar.

(35) Professor White taught Cognitive Grammar to me.

According to Cognitive Grammar, in acts of showing, teaching and communication, abstract things such as knowledge and ideas are transferred and there is a clear difference in meaning between the two constructions. The alternated construction, such as (34), suggest that professor White's teaching had some effect on me and I may be familiar with Cognitive Grammar now, whereas the canonical construction simply states that I was taught the theory

of Cognitive Grammar (Radden and Dirven 2007). Most participants recognized this difference claiming that (34) means ‘I know Cognitive Grammar now’, whereas (35) means I simply took that course. However, 5 out of 15 of them said there was no difference in meaning between the two sentences. Still, we conclude that the speakers’ reasoning is in line with the explanations provided by Cognitive Grammar. Other examples also show that most speakers perceive the difference in meaning between the two constructions based on their knowledge of the world, e.g. *I sent Cambridge (institution) my new book manuscript* / *I sent my new book manuscript to Cambridge (town)* or based on the thing they wish to emphasize – *He promised his grandchildren the money (grandchildren)* / *He promised the money to his grandchildren (money, as in inheritance)*.

5.3.2 Students of English (native speakers of Croatian)

We gave the same questionnaire in English to a group of 20 Croatian students of English to see whether and how much their answers might differ from those given by native speakers of English. When it comes to the first question, the results of both groups are pretty much the same. The students of English also preferred the alternated construction in cases of prototypical and beneficial transfer, saying that the alternated construction is shorter, more natural and less formal, but also claiming that indirect objects (i.e. recipients) should precede the direct ones (i.e. themes). They also said that the alternated construction as in, for example, *Phil gave his wife a big hug* sounds more personal/intimate which is again a signal that the speakers take into account pragmatics and their experience when choosing the preferred construction to express their thoughts. This is further supported by their claims that the canonical construction of the sentence *Do a favor to your old friend* sounds hostile, sarcastic, or even as if there is a third party in the situation asking one person to do a favor to somebody else. Just like the native speakers, the students of English completely dismissed the sentences *I’ll donate the charity \$50* and *He announced the delegates his decision*, saying that it is more important to stress the amount of money because the verb *donate* already entails ‘to charity’ and that one cannot announce the delegates, but only the decision which makes that sentence ambiguous. Curiously enough, just like the natives, some students also said that the situation expressed by the sentence *He announced his decision to the delegates* sounds better because the context it describes is also formal, once again proving that our knowledge of the world influences the language we use.

In the second question, the results were also very similar to those of the native speakers. Once again, the most acceptable sentences were cases of beneficial transfer expressing a creative act in the alternated constructions, while non-creative act was preferred with the canonical construction. The students of English also dismissed the sentence where metaphorical transfer was expressed by the canonical construction (*He gave me a fright*), rating it as the least acceptable of all 15 sentences. The overall quantitative results for this question are provided in Table 2.

Sentence	NA	AP	RA	A	CA	AM
a) The dressmaker designed me a lovely dress.	0	2	10	5	3	3,45
b) I'll bake you a cake.	0	1	0	3	16	4,7
c) Jennifer sent David's office a bunch of flowers.	4	7	7	1	1	2,4
d) He played us a wonderful sonata.	0	1	4	9	6	4
e) Honey, could you please fix me a hamburger?	0	3	0	6	11	4,25
f) He gave a fright to me.	12	5	2	1	0	1,6
g) I'll bake a cake for you.	0	0	2	6	12	4,5
h) Jennifer sent a bunch of flowers to David's office.	0	0	0	1	19	4,95
i) The dressmaker shortened me the dress.	5	8	4	3	0	2,25
j) Could you fix me my drawer?	7	7	2	1	3	2,3
k) Honey, could you please fix a hamburger for me?	6	3	4	2	5	2,6
l) He played us the piano.	5	5	4	3	3	2,7
m) He gave me a fright.	0	1	0	3	16	4,7
n) Could you fix my drawer for me?	0	0	3	4	13	4,5

*NA – not acceptable; AP – awkward, but possible; RP – relatively possible; A – acceptable; CA – completely acceptable; AM – average mean

Table 2. Students of English rating the acceptability of ditransitive constructions

When it comes to the third question, once again the most acceptable sentences proved to be those expressing metaphorical transfer – all four of them were chosen as most acceptable by at least some speakers (*He gave me an idea* – 95%; *He gave it a look* – 90%; *He gave us a speech* – 70%; *He gave me a thought* – 35%). However, in the other four sentences with a beneficiary as an indirect object (unlike the native speakers who chose only the first sentence - *Could you cook me a meal?*), the students of English dismissed entirely only the sentence *Could you taste me this wine?*, whereas the other two were chosen by 5% of the speakers (*Could you paint me a room?* and *Could you make me my bed?*).

In the fourth question where they were asked about the differences in meaning between the two constructions, for the sentences *Professor White taught me Cognitive Grammar* / *Professor White taught Cognitive Grammar to me* the students of English also said that the first sentence implied successful transfer of knowledge, while the second one implied only attending the course. The most interesting example here were sentences

(36) He promised his grandchildren the money.

(37) He promised the money to his grandchildren.

for which 11 out of 20 students said there was no difference in meaning between them. Those who felt there was a difference had conflicting opinions; some said that (36) was about any money (e.g. pocket money), whereas others said the money was actually inheritance. The same holds for (37); opinions also differ here on whether the money in question is indeed inheritance or some other kind of gift. However, the question of emphasis was quite clear here – the speakers said that in (36) emphasis was on the money, whereas in (37) it was on the grandchildren, which is in accordance with the end-focus principle.

Generally speaking, both groups of participant provided similar answers to the given questions. Native speakers gave answers based on their native speaker intuition – something either sounded right or wrong, and they were sometimes unable to explain why, they simply felt it was either a proper or incorrect English sentence. On the other hand, we expected the students of English to provide more specific explanations for their answers, and mainly they did. Moreover, they mentioned more often language economy and the principle of markedness, which shows that they indeed possess specific linguistic knowledge that influenced their answers. All things considered, we believe that the explanations provided by both groups of participants (especially those referring to the questions of preference and the difference in meaning) follow the general ideas of Cognitive Grammar; namely, the idea that the grammatical structures we use reflect our physical, psychological and social experiences, i.e., that the way in which we perceive the world around us determines our choice of grammatical structures (in this case ditransitive constructions).

5.3.3. Native speakers of Croatian

A group of fifteen native speakers of Croatian was given a similar questionnaire, but somewhat longer and more detailed since dative alternation in Croatian has some language-specific properties not present in English. The first four questions were based on the same

principle as the corresponding ones in the English questionnaire. However, the Croatian questionnaire had one more question, the fifth one, which was divided into three separate subsets of questions – A, B, and C. This was due to the fact that Croatian constructions that undergo dative alternation also exhibit some other features that we wanted to test, such as aspectual differences of the verb, omission of certain arguments and passivization. Just like with native speakers of English, we expected native speakers of Croatian to rely on their intuition when explaining their choices since none of them was a specialist in any language.

In the first questions, the native speakers of Croatian were presented with five pairs of sentences in which they had to choose the one that sounded more natural to them and explain why. It is interesting to note that in 3 out of 5 sentences the speakers were quite undecided as to the construction they preferred. In the first three pairs of sentences, the ratio of canonical versus alternated construction was 8/7, 7/8 and 6/9 respectively. For example, in the first pair of sentences

(38) Domaćin je poslužio gostima kavu i kolače.

‘The host served coffee and cakes to the guests.’

(39) Domaćin je poslužio goste kavom i kolačima.

‘The host served the guests coffee and cakes.’

8 speakers preferred the canonical Croatian construction, saying that it sounded more natural, it was used more often and it was more important to answer who was being served than what. On the other hand, 7 speakers preferred the alternated construction saying that it was more appropriate for the context it described, it sounded nicer and the emphasis was on coffee and cakes. An interesting explanation said that (38) sounded as if a waiter served the guests coffee and cakes, and not the host (e.g. of a party). This also shows that speakers can construe the same situation from two different points of view, depending on how they perceive it. The fact that this particular speaker felt as if a waiter was the one to serve coffee and cakes shows that they rely on their experience, since waiters are usually the ones who serve food and beverage. The other two sentence pairs where the difference in the number of preferred constructions was also close had similar explanations; however, the alternated construction was preferred here due to some semantic constraints on the verbs *darivati* (to give as a gift) and *ponuditi* (to offer). Another interesting example were sentences

(40) Hana je Ivanu darovala poljubac.

‘Hana gave a kiss to Ivan (as a gift).’

(41) Hana je Ivana darovala poljupcem.

‘Hana gave Ivan a kiss (as a gift).’

where only 2 speakers preferred the alternated construction. The other 13 speakers said that (40) sounded more natural and suggested a more intimate relationship, which again proves that speakers’ experience and knowledge of the world influence their choice of construction (kissing normally entails a more intimate relationship).

In the second question, the speakers were presented with a set of 15 sentences with different types of objects (animate/inanimate, heavy NPs with different word order) and ditransitive verbs (aspectual counterparts). The overall quantitative results are given in Table 3.

The most acceptable sentences were those with the verb *darovati/darivati* (aspectual counterparts of the verb to give as a gift) describing a transfer of a theme argument (both animate and inanimate) from a volitional agent to a willing recipient. Sentences with the verb *nuditi* (to offer) also ranked high; here we wanted to test how the heavy NP as a recipient influenced the choice of construction. Since Croatian has free word order, there were four possible combinations in both canonical and alternated construction. The results show that the most acceptable sentences (both canonical and alternated variants) are those in which the heavy NP recipient is at the end of the sentences. Zovko Dinković (2007) came to the same conclusion. In her words, the heaviness constraint does not influence the choice between the canonical and alternated construction in Croatian; it simply conditions the preference of different word orders in both constructions, depending on the heaviness of arguments.

As expected, the least acceptable sentence was the following:

(42) Majka je podarila sina psom.

‘The mother gave the son a dog (as a gift).’

Sentence	NA	AP	RA	A	CA	AM
a) Nudili su svakomu tko je došao na vjenčanje šampanjac.	0	2	8	5	0	3,2
b) Bogati su darivali beskućnike odjećom.	0	2	2	6	5	3,8
c) Majka je darovala sina psom.	7	2	5	1	0	2
d) Novine su darivale dužnosnika pogrdnim izrazima.	6	5	2	1	1	2,1
e) Nudili su šampanjac svakomu tko je došao na vjenčanje.	0	1	3	6	5	4
f) Bogati su darovali beskućnicima odjeću.	1	0	1	3	10	4,4
g) Majka je podarila sinu psa.	4	1	2	5	3	3,1
h) Nudili su svakoga tko je došao na vjenčanje šampanjcem.	2	3	1	5	4	3,4
i) Novine su darivale dužnosniku pogrdne izraze.	7	2	4	2	0	2,1
j) Bogati su darovali beskućnike odjećom.	7	1	1	4	2	2,5
k) Majka je darovala sinu psa.	0	0	0	5	10	4,7
l) Nudili su šampanjcem svakoga tko je došao na vjenčanje.	0	2	4	3	6	3,9
m) Bogati su darivali beskućnicima odjeću.	0	0	2	5	8	4,4
n) Majka je podarila sina psom.	10	2	3	0	0	1,5

*NA – not acceptable; AP – awkward, but possible; RP – relatively possible; A – acceptable; CA – completely acceptable; AM – average mean

The problem with this sentence is not only that the theme argument here is an animate being, but the verb *podariti* (perfective form of the verb *to give as a gift*) in Croatian can also be interpreted as ‘to give birth’, which makes this sentence semantically and logically unacceptable.

The third question had a list of eight sentences: four of them had a heavy NP as the theme argument in both canonical and alternated construction and we wanted to test which word order was most acceptable for the speakers – heavy NP at the end of the sentence or right after the verb. The other four sentences all had the same verb – *ponuditi* (to offer) – in the alternated construction with different theme arguments. The most acceptable sentence among the first four was the canonical construction in which a heavy theme argument was at the end of the sentence (chosen by 86.6% of speakers), with the alternated construction with a heavy theme argument at the end following at 66.6%. This is in line with Zovko Dinković’s

(2007) conclusions: heavy themes have to appear in sentence-final position, and since this is the position of unmarked focus (cf. Lambrecht 1994) in a sentence, we might suppose that the focus has to be on themes if they are heavy NPs. Consequently, heavy themes have to appear in sentence-final position, while heavy recipients are not subject to such a constraint (2007:15). When it comes to the other four sentences, the most acceptable sentence was the one in which the theme argument referred to a beverage. This was expected because the verbs *nuditi/ponuditi* ‘to offer’ in alternated constructions are subject to a constraint due to which their theme arguments are restricted to things that are consumed through the mouth, i.e. food, beverage and cigarettes/cigars (Zovko Dinković 2007). This was confirmed in our research, too, since the sentence with the theme argument ‘money’ was not chosen as most acceptable by anyone, whereas the one with the theme argument ‘transport’ was chosen by only 13.3% of speakers. The remaining sentence, the one in which the theme argument was ‘a cigar’, was chosen by 53.3% of speakers, which confirms the existence of the constraint on the theme arguments of the verbs *nuditi/ponuditi*.

In the fourth question, the participants were offered four pairs of sentences and they had to say whether they felt any difference in meaning between the canonical construction and the alternated one. If they felt the difference, we asked them to explain what the difference was. In all four pairs of sentence more than half participants felt no difference between the two variants. The most interesting example were sentences

(42) Darovali su bolnici medicinsku opremu, ali ju nije dobila.

‘They gave medical equipment to the hospital (as a gift), but it did not get it.’

(43) Darovali su bolnicu medicinskom opremom, ali ju nije dobila.

‘They gave the hospital medical equipment (as a gift), but it did not get it.’

In this case, 12 out of 15 participants did not feel any difference between the two constructions and our expectations were not confirmed since we expected them to feel the difference in the (un)successfulness of transfer. According to Levin and Rappaport Hovav (2002:5),

‘...expression of recipient as possessor generates successful transfer implicature (since the prototypical possessor realizes a possession relation), while expression of recipient as goal may generate an implicature of nonsuccess (theme reaches goal, but goal does not take possession).’

This actually means that in alternated constructions there is the successful transfer implicature, whereas in canonical constructions the transfer need not be successful. Zovko Dinković (2007) analyzed the same example saying that this claim by Levin and Rappaport Hovav (2002) holds for Croatian, too. In her interpretation, sentence (44) is questionable because the first part of the sentence in the alternated construction carries the successful transfer implicature, but the second part claims that the transfer was not successful. In our research only three participants found the sentence (44) wrong and unnatural, but none of them mentioned the (un)successfulness of transfer in their explanation. The only thing they mentioned as the difference was that (43) was about specific medical equipment which the giver already possessed, whereas (44) was about medical equipment in general. Another example that has to do with constraints on theme arguments in alternated constructions of the verbs *nuditi/ponuditi* (to offer) is the following pair of sentences:

(44) Nudili su nam pečenog purana.

‘They offered baked turkey to us.’

(45) Nudili su nas pečenim puranom.

‘They offered us baked turkey.’

According to Zovko Dinković (2007:18), if the verbs *nuditi/ponuditi* (to offer) refer to a single entity, only the alternated construction conveys the meaning ‘offer to eat/drink’. Canonical dative construction in this case usually conveys a different meaning, e.g. ‘offer to buy/take away’. Although 8 out of 15 participants in our research felt no difference in meaning between the canonical and the alternated construction in Croatian, those who did feel the difference said that (45) sounds as if the turkey was offered to them to take away (as a gift), whereas in (46) it was offered to eat. However, they also said that in (45) the turkey was whole and in (46) they were offered only a part of that turkey. The participants also had

differing opinions on whether the turkey was already baked or the agent simply offered to bake it for us. However, they did not agree upon which of these two meanings is expressed by which construction – both constructions were associated with both the already baked turkey and the one that was still not baked!

In the fifth question, the first subset of questions (A) had three pairs of sentences, either in the canonical construction or in the alternated one. The only difference between the two constructions in a pair was in the aspect of the verb, as we wanted to see whether the speakers preferred perfective or imperfective verbs. In 2 out of 3 pairs the participants preferred the variant with a perfective form of the verb. The only exception were sentences

(46) Djeca su darovana slatkišima.

‘The children were given (PERF²¹) candy (as a gift).’

(47) Djeca su darivana slatkišima.

‘The children were given (IMPF²²) candy (as a gift).’

We believe the reason why in this example the imperfective variant was preferred is due to the fact that the two sentences in this example were both passive, and the imperfective form in this case can be interpreted as meaning that the children were the one that were given (theme) to the candy (recipient).

In the subset B, there were six sentences in which one argument was omitted (either the recipient or the theme argument) and we asked the participants to state whether these sentences were acceptable to them or not and explain their answers. Native speakers of Croatian found 3 out of 6 sentences with omitted arguments acceptable, whereas 3 were not acceptable. Among the sentences that were not found acceptable, two had no theme argument, whereas one was missing the recipient. It is interesting to note that all three unacceptable

²¹ Perfective aspect

²² Imperfective aspect

sentences had the verb *darovati* (PERF) in them, which leads us to the conclusion that the reason why these particular sentences were dismissed by native speakers is the situation we associate with the verb *darovati* (to give as a gift) in Croatian (i.e. you usually give something to somebody because you want to), which means that both the theme argument and the recipient arguments have to be stated. Zovko Dinković (2007:5) did a similar research and she found that aspect was the main reason why certain sentences with omitted recipient arguments were preferred over others; namely, sentences with imperfective verb forms were found acceptable even with recipient arguments being omitted, while those same sentences with perfective verb forms were found unacceptable by all speakers. Our research showed the same – native speakers dismissed the sentences with perfective verb forms in which the recipient was omitted.

In the subset C, the participants were presented with four pairs of passive sentences with both perfective and imperfective verbs and we wanted to check whether there was any difference in meaning between the two sentences in a pair, as well as which one was more acceptable and/or natural for the speakers. It is interesting to note that native speakers generally saw no difference in meaning between sentences with perfective and imperfective verbs (they all said the only difference was in the aspect and/or duration of the action); however, they all preferred the sentences with perfective form. The only interesting example in this subset of questions were sentences

(48) Nuđeni smo tortom.

‘We were offered (IMP) a cake.’

(49) Ponuđeni smo tortom.

‘We were offered (PERF) a cake.’

where the participants said that (49) sound as if somebody was bothering us the entire time to have some cake, but the offer no longer stands. Only one person said that (49) sounded more natural because it meant that we actually got the cake, whereas in (50) it was only offered to us.

5.3.4. Native speakers of Croatian (students of English)

A group of 20 students of English was the only one to fill in both questionnaires, in English as well as in Croatian. Although they are native speakers of Croatian we expected this group to provide more ‘scientific’ explanations for their answers because they are at the same time language specialists. However, in completing the questionnaires in Croatian they also relied mostly on their native speaker intuition, describing sentences usually as sounding more natural, better or as being heard more often.

In the first question their results were pretty much the same as those of native speakers of Croatian who are not specialist in any language. Among five pairs of sentences, in two cases the alternated construction was preferred over the canonical one, in the other two the canonical one was preferred. In the first pair of sentences

(50) Domaćin je poslužio gostima kavu i kolače.

‘The host served coffee and cakes to the guests.’

(51) Domaćin je poslužio goste kavom i kolačima.

‘The host served the guests coffee and cakes.’

an equal number of participants choose both variants (10:10). The reasons they provided for their choices either had to do with one sentence sounding more natural or simpler, or sometimes cases (theme in the accusative case, not the instrumental). One interesting explanation said that in (52) the agent is sitting together with the guests and drinking coffee and eating cakes, whereas in (51) he only served the guests. This example again shows how our perception of the world around us influences the language we use (if you have guests, you will usually sit with them and drink coffee instead of just walking around the table and filling other people’s cups).

In the second question as well the results were almost the same. The most acceptable sentences were those with the verb *darovati/darivati* (aspectual counterparts of the verb *to give as a gift*) describing a transfer of a theme argument (both animate and inanimate) from a volitional agent to a willing recipient. Sentences with the verb *nuditi* (to offer) also ranked high and once again sentences with heavy NPs recipients at the end (regardless of their canonical or alternated form) were preferred over those in which heavy NP recipient came right after the verb. However, unlike the first group of native speakers (who found the sentence *Majka je podarila sina psom* the least acceptable), for the students of English the least acceptable sentence was

(52) *Majka je darovala sina psom.*

‘The mother gave the son a dog.’

The only explanation we find for this kind of result is that the theme argument in the alternated construction is preferred when it refers to an inanimate being, as is the case with the sentence *Bogati su darovali beskućnike odjećom*, which was found relatively acceptable by most speakers. The overall quantitative results for this question are provided in Table 4.

In the third question, once again the most acceptable sentence among the first four (with a heavy NP as the theme argument in both canonical and alternated construction) was

(53) *Nudili su gostima šampanjac koji su uvezli iz Francuske.*

‘They offered to the guests the champagne which they imported from France.’

with the heavy NP theme at the end of the sentence (it was chosen by 90% of the speakers). It is interesting that none of the students chose either sentence with the heavy NP theme right after the verb as most acceptable. The results for the other four sentences (with the verb *ponuditi* (to offer) in the alternated construction with different theme arguments – *He offered us a drink* (90%) / *money* (5%) / *transport* (20%) / *a cigar* (60%)) once again prove that there is indeed a semantic constraint on the verb *ponuditi* (to offer) in Croatian due to which their

theme arguments in alternated constructions are restricted to things that are consumed through the mouth, i.e. food, beverage and cigarettes/cigars.

Sentence	NA	AP	RA	A	CA	AM
a) Nudili su svakomu tko je došao na vjenčanje šampanjac.	1	6	4	5	4	3,25
b) Bogati su darivali beskućnike odjećom.	0	3	2	7	8	4
c) Majka je darovala sina psom.	15	4	1	0	0	1,3
d) Novine su darivale dužnosnika pogrdnim izrazima.	10	5	4	1	0	1,8
e) Nudili su šampanjac svakomu tko je došao na vjenčanje.	0	0	1	3	16	4,75
f) Bogati su darovali beskućnicima odjeću.	0	0	1	2	17	4,8
g) Majka je podarila sinu psa.	6	1	3	4	6	3,15
h) Nudili su svakoga tko je došao na vjenčanje šampanjcem.	0	3	4	5	8	3,9
i) Novine su darivale dužnosniku pogrdne izraze.	7	8	2	3	0	2,65
j) Bogati su darovali beskućnike odjećom.	3	7	2	5	3	2,9
k) Majka je darovala sinu psa.	1	0	1	2	16	4,6
l) Nudili su šampanjcem svakoga tko je došao na vjenčanje.	0	2	0	5	13	4,45
m) Bogati su darivali beskućnicima odjeću.	0	0	1	10	9	4,4
n) Majka je podarila sina psom.	11	5	2	2	0	1,75

*NA – not acceptable; AP – awkward, but possible; RP – relatively possible; A – acceptable; CA – completely acceptable; AM – average mean

Table 4. Native speakers of Croatian (students of English) rating the acceptability of ditransitive constructions

In the fourth question (where they were asked if there was a difference in meaning between the canonical and the alternated construction) in 2 out of 4 sentences more than half participants felt no difference between the two constructions, and in the other two sentences approximately 1/3 of the participants felt no difference. The most interesting example in this group were sentences

(54) Tvrтка je bolnici donirala novac.

‘The company donated the money to the hospital.’

(55) Tvrтка je bolnicu donirala novcem.

‘The company donated the hospital the money.’

The verb *donirati* (to donate) in Croatian is not one of the verbs that allow dative alternation and we gave this example to the participants precisely to see whether they will dismiss the alternated construction as ungrammatical. Most speakers said that (56) sounded wrong, but they did not know why. However, six people felt no difference whatsoever between the two constructions which means that the alternated construction with the verb *donirati* (to donate) is not rejected by everyone. Those who did comment on the difference in meaning said that ‘the money’ in (55) was the one which the company had collected (e.g. through fund-raisers) and the hospital can use it for anything it wants, whereas in (56) it was the company’s money which it donated so that the hospital can be built or renovated.

In the first subset of questions (A) in the fifth question (where the only difference within a pair of sentences was in the aspect of the verb), just like with the first group of participants the only example where the imperfective form was preferred was the sentence

(56) Djeca su darivana slatkišima.

‘The children were given (IMP) candy (as a gift).’

most probably due to the fact that the imperfective form in this case can be interpreted as meaning that the children were the ones that were given (theme) to the candy (recipient). In the example with the verbs *služiti/poslužiti* (to serve) the perfective form was preferred; we believe this is so because the imperfective form *služiti* can have another interpretation – to serve somebody, i.e. to be somebody’s servant, whereas the perfective form *poslužiti* is more often in contexts that involve food and beverage. When it comes to the example with the

verbs *nuditi/ponuditi* (to offer), more than half participants found both constructions equally acceptable.

In the subset B, there were 6 sentences in which either the recipient or the theme argument was omitted. Unlike the first group of native speakers of Croatian (where 3 out of 6 sentences with omitted arguments were found unacceptable), the students of English found 4 out of 6 sentences unacceptable. The difference between the two groups was in the sentence

(57) Služeni su kava i kolači.

‘Coffee and cakes were served (IMPF).’

which the first group found acceptable, whereas the students of English dismissed it as unacceptable. It is interesting to note that none of them had a problem with the omitted participant argument; rather, their explanations were that the verb *služiti* (to serve, IMPF) implies something negative (e.g. to serve a master) or that (59) sounds as if ‘coffee and cakes’ are people who are being served. One person also said that (59) did not sound intimate enough, which would suggest that the situation described by this sentence implies for the speakers a more intimate atmosphere (where people who serve that coffee and cakes usually know the people who are being served, or they are even friends in an informal gathering, rather than guests at some formal event).

In the subset C (in which there were four pairs of passive sentences with both perfective and imperfective verbs), the students of English also mainly claimed that the only difference between the two variants was in the verb aspect and/or duration, not in the meaning. Those who did see some specific difference in meaning between the perfective and imperfective variant mentioned other factors that influenced their choice, such as context of situation (formal/informal; intimate or not) or the (un)successfulness of the transfer. Just like the first group, they all found sentences with perfective forms more acceptable and more natural.

5.3.5 Native speakers of Croatian (students of Croatian)

The last group of participants were 15 native speakers of Croatian who are at the same time either students of Croatian or they have already graduated in it. Since these participants were at the same time native speakers and language specialist, we expected them to be more sensitive to syntactic phenomena such as dative alternation and to provide explanations that are based more on their knowledge of language than on their native speakers' intuition.

In the first question, the students of English preferred the canonical construction over the alternated one in 4 out of 5 examples. The most interesting example here were sentences

(58) Katar se odlučio SAD-u donirati 100 milijuna dolara.

‘Qatar decided to donate \$100 million to the USA.’

(59) Katar se odlučio SAD donirati sa 100 milijuna dolara.

‘Qatar decided to donate the USA \$100 million.’

since all 15 participants dismissed (60) as unnatural or wrong. This is not surprising since the verb *donirati* (to donate) is not one of the verbs that allow dative alternation in Croatian. However, the explanations that the students provided for their choice had more to do with the structure of the sentences themselves than with dative alternation. For example, most students said that the best way of describing this situation would be to say *Katar je odlučio SAD-u donirati 100 milijuna dolara*, because the use of reflexive pronoun *se*²³ in (59) and (60) indeed sounds awkward. Only one student said that the verb *donirati* (to donate) does not function well in the alternated construction. This suggests that the other students saw nothing wrong with the verb *donirati* (to donate) itself in the alternated construction; similar thing happened with the second group of participants (students of English) who also did not dismiss the verb *donirati* (to donate) itself in the alternated construction.

²³ This particular example with the reflexive pronoun *se* comes from the *Croatian National Corpus*

In the second question, the results for this group were somewhat different from those of the previous two groups. The most acceptable sentence here was

(60) Majka je darovala sinu psa.

‘The mother gave a dog to the son (as a gift).’

whereas the least acceptable one was its alternated variant

(61) Majka je darovala sina psom.

‘The mother gave the son a dog (as a gift).’

We were surprised to see that the most acceptable sentence was the one whose theme argument was animate, since the other two groups preferred sentences with inanimate theme arguments. On the other hand, all three groups quite disliked the alternated construction. Another example that was quite disliked by the students of English was the sentence

(62) Novine su darivale dužnosniku pogrdne izraze.

‘The newspapers bestowed derogatory words upon the official.’

However, its alternated construction was found relatively acceptable by most speakers. Since these are examples of metaphorical transfer (and given that the other two groups found these examples awkward, but possible), we conclude that in cases of metaphorical transfer the alternated construction is preferred. The overall quantitative results for the second question are presented in Table 5.

Sentence	NA	AP	RA	A	CA	AM
a) Nudili su svakomu tko je došao na vjenčanje šampanjac.	0	3	3	5	4	3,67
b) Bogati su darivali beskućnike odjećom.	1	2	5	4	3	3,4
c) Majka je darovala sina psom.	12	3	0	0	0	1,2
d) Novine su darivale dužnosnika pogrđnim izrazima.	2	7	3	2	1	2,53
e) Nudili su šampanjac svakomu tko je došao na vjenčanje.	0	0	2	3	10	4,53
f) Bogati su darovali beskućnicima odjeću.	0	2	3	0	10	4,2
g) Majka je podarila sinu psa.	2	8	1	3	1	2,53
h) Nudili su svakoga tko je došao na vjenčanje šampanjcem.	1	0	6	3	5	3,73
i) Novine su darivale dužnosniku pogrđne izraze.	7	4	4	0	0	1,8
j) Bogati su darovali beskućnike odjećom.	6	1	3	5	0	2,47
k) Majka je darovala sinu psa.	0	0	1	2	12	4,73
l) Nudili su šampanjcem svakoga tko je došao na vjenčanje.	1	0	4	2	8	4
m) Bogati su darivali beskućnicima odjeću.	2	0	3	3	7	3,87
n) Majka je podarila sina psom.	12	0	3	0	0	1,4

*NA – not acceptable; AP – awkward, but possible; RP – relatively possible; A – acceptable; CA – completely acceptable; AM – average mean

Table 5. Native speakers of Croatian (students of Croatian) rating the acceptability of ditransitive constructions

In the third question, the results for this group were almost the same as those of the previous two groups of participants. Once again the most acceptable sentences among the first four (with a heavy NP as the theme argument in both canonical and alternated construction) were those with the heavy NP theme at the end of the sentence (and the canonical construction ranking slightly better than the alternated one – 66%: 60%). However, none of the speakers dismissed completely the sentences with the heavy NP theme right after the verb (as the students of English did, for example). The results for the other four sentences (with the verb *ponuditi* (to offer) in the alternated construction with different theme once again proved the existence of a semantic constraint on the verb *ponuditi* (to offer) in Croatian due to which their theme arguments in alternated constructions are restricted to things that are consumed

through the mouth, i.e. food, beverage and cigarettes/cigars (the example with ‘a drink’ as the theme argument was chosen as most acceptable by 86.6% of students and the one with ‘a cigar’ by 40%). None of the participants chose the sentences with ‘money’ and ‘transport’ as most acceptable.

In the fourth question (where they were asked if there was a difference in meaning between the canonical and the alternated construction), unlike in the first two groups, most students of Croatian felt some kind of difference in meaning between the two constructions in all four examples. An interesting example were sentences

(63) Ponudio mi je kavu.

‘He offered some coffee to me.’

(64) Ponudio me je kavom.

‘He offered me some coffee.’

where most participants said that in (65) coffee was not yet prepared, i.e. the agent offered to make some coffee for the recipient, whereas in (66) the coffee was already ready to drink. This is interesting because in the other two groups the same explanations were provided, only for different sentences. Native speakers who are not language specialists and the students of English said that (65) meant the coffee was already prepared, while in (66) it still had to be made! These conflicting opinions provide fertile ground for further research into this particular example on a bigger number of participants since it would be more than interesting to see which opinion ‘wins’ in the end.

In the first subset of questions (A) in the fifth question (where the only difference within a pair of sentences was in the aspect of the verb), just like the students of English, the students of Croatian chose the sentence

(65) Djeca su darivana slatkišima.

‘The children were given (IMP) candy (as a gift).’

as the only example where the imperfective form was preferred, for the reason we have already explained in the previous section. In the example with the verbs *služiti/poslužiti* (to serve) the perfective form was preferred; again, we believe this is so because the imperfective form *služiti* can have another interpretation – to serve somebody, i.e. to be somebody’s servant, whereas the perfective form *poslužiti* is more often in contexts that involve food and beverage. When it comes to the examples with the verbs *nuditi/ponuditi* (to offer), 10 out of 15 participants found both constructions equally acceptable.

In the subset B (with 6 sentences in which either the recipient or the theme argument was omitted), the students of Croatian had the same results as the students of English - 4 out of 6 sentences were found unacceptable. The only two sentences that were found acceptable in our opinion have more to do with the semantic constraints on the verbs *služiti/poslužiti* (to serve) and *darovati/darivati* (to give as a gift), rather than with the fact that in both cases the recipient was omitted.

In the subset C (with four pairs of passive sentences with both perfective and imperfective verbs), the students of Croatian again had almost the same results as the students of English. They, too, claimed that the only difference between the two variants was in the verb aspect and/or duration, not in the meaning itself. Those who did see some specific difference in meaning between the perfective and imperfective variant mentioned other factors that influenced their choice, such as context of situation or the (un)successfulness of the transfer (especially with the verbs *nuditi/ponuditi* – to offer). Just like the previous two groups, they all found sentences with perfective forms more acceptable.

If we compare the three groups of native speakers of Croatian, we find that our expectations were mainly confirmed. Native speakers of Croatian who are not specialists in any other language relied mainly on their native speaker intuition when answering the questions and providing explanations for their choices. Their explanations were more often based on their experience and knowledge of the world, since they included specific situations from everyday life (e.g. that waiters usually serve food and beverage and that a relationship needs to be rather intimate to involve a kiss). Generally speaking, we could say that this group

was not as 'critical' towards certain constructions as the other two groups of language students were, since they found some examples of sentences acceptable which in the other two groups were not found acceptable.

The students of English and the students of Croatian had very similar results. However, their explanations proved not to be as based on their knowledge of language as we have expected. In a great number of examples their native speaker intuition prevailed and their answers also said that something is wrong or right just because it sounds more natural. On the other hand, there were examples of sentences where they provided explanations that had to do only with the grammatical form of a sentence, certain words within it, or style, rather than with the difference in meaning or cases (which was what we expected them to comment upon).

6. Final remarks

Ditransitive constructions and dative alternation have attracted the attention of linguists for quite some time. Earlier theories (mainly formal) considered dative alternation to be merely a change in syntactic relations within a sentence and they were primarily concerned with determining which of the two subjects in a ditransitive construction corresponds to the object of a monotransitive construction. It soon became obvious that these kinds of phenomena cannot be explained by syntax only and that semantics has to be taken into account, too. With the introduction of thematic roles into the analysis of ditransitive constructions and dative alternation (mainly functional approaches), the importance of semantics and meaning in these types of constructions was widely recognized. More recent theories, such as Information Structure, Construction Grammar and Cognitive Grammar provide new insights into how the speaker's choice of construction reflects how they construe a situation described by that construction in their minds. We believe that a great contribution of these theories to the analysis of dative alternation (especially Cognitive Grammar) is the way in which they explain situations of metaphorical transfer and it would be useful to do some more research with the constructions that do not include prototypical acts of transfer.

Since dative alternation is quite rare in case-marking languages such as Croatian, we decided to research the way in which it functions in Croatian, too. If we compare the results of the research on the speakers of English and the speakers of Croatian, it becomes more than

obvious that dative alternation in these two languages functions differently. Due to the differences between the two languages (e.g. (non)existence of cases, the question of word order etc.), the functioning of dative alternation is determined in both languages by different semantic, pragmatic and other factors, although there are also some universal features, too.

7. Conclusion

Our claim was that ditransitive constructions and dative alternation are best explained by Cognitive Grammar since it claims that grammar is the solution that speakers have found to structure their thoughts in order to communicate them to other people. As products of speakers, the words and grammatical structures they use reflect their physical, psychological and social experiences. Our primary concern was with the phenomenon of dative alternation in English and we believe that the results of the research on native speakers of English and Croatian students of English support our claim. The answers the participants provided show that their experiences truly influence their choice of construction, i.e. that the way in which we perceive the world around us determines the language we use. Since English allows dative alternation with some 30 verbs, it is fairly common in language use which is why it was easier to test the English speaking participants. Croatian, on the other hand, allows dative alternation with only 3 verbs (8 if we count their aspectual counterparts) and the alternated construction is not as common in use as the canonical one. Moreover, the alternated construction in Croatian is subject to many semantic and pragmatic constraints (due to some inherent meanings of the verbs that allow it), which is why its use is often associated with more formal style (this was also recognized by the Croatian speaking participants who described the alternated construction as stylistically marked or pertaining to more formal situations). When it comes to dative alternation in Croatian, many of the findings by Zovko Dinković (2007) were confirmed by our research, too. However, since there is a time period of some six years between her work and ours (twelve, if we take into account her work from 2001), we showed that some of the speakers' perception on dative alternation has changed. In our opinion, the most interesting example of that change is the use of the verb *donirati* (to donate) in the alternated construction. Although *donirati* is not one of the Croatian verbs that allow dative alternation, we found that the speakers do not dismiss the use of the verb itself in the alternated construction. It would be interesting to do some further research on this issue since it appears that the verb *donirati* (to donate) is becoming acceptable in the alternated

construction, too. Since dative alternation in English has already been dealt with from the point of view of Cognitive Grammar, it would be useful to do some more research in this vein on the issue of dative alternation in Croatian, since the phenomenon is rare in any case-marking language, including Croatian.

8. Appendix 1

a) the questionnaire in English

University of Zagreb

Faculty of Humanities and Social Sciences

Department of English

Student: Vedrana Marinović

This questionnaire is part of the research conducted in order to collect data for a graduation thesis. Participation in the research is voluntary and anonymous.

Age: _____

Level of education: _____

1st language (mother tongue): _____

I. In each pair of sentences circle the one you would prefer in everyday communication and briefly explain why.

1.

a) I'll mail you the report.

b) I'll mail the report to you.

2.

a) Phil gave his wife a big hug.

b) Phil gave a big hug to his wife.

3.

a) I'll donate the charity \$50.

b) I'll donate \$50 to the charity.

4.

a) Do your old friend a favor.

b) Do a favor to your old friend.

5.

a) He announced the delegates his decision.

b) He announced his decision to the delegates.

II. For the following sentences, circle on the scale from 1 to 5 how acceptable they are to you.

1 – not acceptable at all

2 – awkward, but possible

3 – relatively acceptable

4 – acceptable

5 – completely acceptable

- | | | | | | |
|--|---|---|---|---|---|
| a) The dressmaker designed me a lovely dress. | 1 | 2 | 3 | 4 | 5 |
| b) I'll bake you a cake. | 1 | 2 | 3 | 4 | 5 |
| c) Jennifer sent David's office a bunch of flowers. | 1 | 2 | 3 | 4 | 5 |
| d) He played us a wonderful sonata. | 1 | 2 | 3 | 4 | 5 |
| e) Honey, could you please fix me a hamburger? | 1 | 2 | 3 | 4 | 5 |
| f) He gave a fright to me. | 1 | 2 | 3 | 4 | 5 |
| g) I'll bake a cake for you. | 1 | 2 | 3 | 4 | 5 |
| h) Jennifer sent a bunch of flowers to David's office. | 1 | 2 | 3 | 4 | 5 |
| i) The dressmaker shortened me the dress. | 1 | 2 | 3 | 4 | 5 |
| j) Could you fix me my drawer? | 1 | 2 | 3 | 4 | 5 |
| k) Honey, could you please fix a hamburger for me? | 1 | 2 | 3 | 4 | 5 |

- l) He played us the piano. 1 2 3 4 5
- m) He gave me a fright. 1 2 3 4 5
- n) Could you fix my drawer for me? 1 2 3 4 5

III. Circle the sentences you find most acceptable among the following:

- a) Could you cook me a meal?
- b) Could you paint me a room?
- c) Could you make me my bed?
- d) Could you taste me this wine?
- e) He gave me an idea.
- f) He gave it a look.
- g) He gave us a speech.
- h) He gave me a thought.

IV. Are there any differences in meaning between the following sentences? If yes, explain where you see the difference.

1.

- a) Professor White taught me Cognitive Grammar.
- b) Professor White taught Cognitive Grammar to me.

2.

- a) He promised me he won't lie.
- b) He promised he won't lie to me.

3.

a) I sent Cambridge my new book manuscript.

b) I sent my new book manuscript to Cambridge.

4.

a) He promised his grandchildren the money.

b) He promised the money to his grandchildren.

Thank you for your participation!

b) the questionnaire in Croatian

Sveučilište u Zagrebu

Filozofski fakultet

Odsjek za anglistiku

Student: Vedrana Marinović

Ovaj upitnik je dio istraživanja za diplomski rad. Sudjelovanje u istraživanju je dobrovoljno i anonimno.

Dob: _____

Stupanj obrazovanja: _____

Mjesto u kojem ste proveli najveći dio života: _____

I. U svakom od sljedećih parova rečenica zaokruži onu koja ti zvuči prirodnije te ukratko objasni zašto.

1.

a) Domaćin je poslužio gostima kavu i kolače.

b) Domaćin je poslužio goste kavom i kolačima.

2.

a) Djed Mraz je darivao djeci slatkiše.

b) Djed Mraz je darivao djecu slatkišima.

3.

a) Konobar je ponudio gostima šampanjac.

b) Konobar je ponudio goste šampanjcem.

4.

a) Hana je Ivanu darovala poljubac.

b) Hana je Ivana darovala poljupcem.

5.

a) Katar se odlučio SAD-u donirati 100 milijuna dolara.

b) Katar se odlučio SAD donirati sa 100 milijuna dolara.

II. Za sljedeće rečenice zaokruži na skali od 1 do 5 koliko su ti prihvatljive.

1 – uopće nije prihvatljiva

2 – zvuči čudno, ali je moguća

3 – relativno prihvatljiva

4 – prihvatljiva

5 – u potpunosti prihvatljiva

- | | | | | | |
|--|---|---|---|---|---|
| a) Nudili su svakomu tko je došao na vjenčanje šampanjac. | 1 | 2 | 3 | 4 | 5 |
| b) Bogati su darivali beskućnike odjećom. | 1 | 2 | 3 | 4 | 5 |
| c) Majka je darovala sina psom. | 1 | 2 | 3 | 4 | 5 |
| d) Novine su darivale dužnosnika pogrđnim izrazima. | 1 | 2 | 3 | 4 | 5 |
| e) Nudili su šampanjac svakomu tko je došao na vjenčanje. | 1 | 2 | 3 | 4 | 5 |
| f) Bogati su darovali beskućnicima odjeću. | 1 | 2 | 3 | 4 | 5 |
| g) Majka je podarila sinu psa. | 1 | 2 | 3 | 4 | 5 |
| h) Nudili su svakoga tko je došao na vjenčanje šampanjcem. | 1 | 2 | 3 | 4 | 5 |
| i) Novine su darivale dužnosniku pogrđne izraze. | 1 | 2 | 3 | 4 | 5 |
| j) Bogati su darovali beskućnike odjećom. | 1 | 2 | 3 | 4 | 5 |
| k) Majka je darovala sinu psa. | 1 | 2 | 3 | 4 | 5 |
| l) Nudili su šampanjcem svakoga tko je došao na vjenčanje. | 1 | 2 | 3 | 4 | 5 |
| m) Bogati su darivali beskućnicima odjeću. | 1 | 2 | 3 | 4 | 5 |
| n) Majka je podarila sina psom. | 1 | 2 | 3 | 4 | 5 |

III. Zaokruži rečenice koje smatraš najprihvatljivijima između sljedećih:

- a) Nudili su gostima šampanjac koji su uvezli iz Francuske.
- b) Nudili su šampanjac koji su uvezli iz Francuske gostima.
- c) Nudili su goste šampanjcem koji su uvezli iz Francuske.
- d) Nudili su šampanjcem koji su uvezli iz Francuske goste.
- e) Ponudio nas je pićem.
- f) Ponudio nas je novcem.
- g) Ponudio nas je prijevozom.
- h) Ponudio nas je cigarom.

IV. Ima li razlike u značenju između sljedećih rečenica? Ako da, objasni u čemu vidiš razliku.**1.**

- a) Ponudio mi je kavu.
- b) Ponudio me je kavom.

2.

- a) Darovali su bolnici medicinsku opremu, ali ju nije dobila.
- b) Darovali su bolnicu medicinskom opremom, ali ju nije dobila.

3.

- a) Nudili su nam pečenog purana.
- b) Nudili su nas pečenim puranom.

4.

- a) Tvrtka je bolnici donirala novac.
- b) Tvrtka je bolnicu donirala novcem.

V.

A) U sljedećim parovima rečenica odaberi onu koja ti je prihvatljivija. Ako su ti obje rečenice jednako prihvatljive, zaokruži obje.

1)

- a) Djeca su darovana slatkišima.
- b) Djeca su darivana slatkišima.

2)

a) Služili su nas kavom i kolačima.

b) Poslužili su nas kavom i kolačima.

3)

a) Nudili su nam tortu.

b) Ponudili su nam tortu.

B) Za svaku od sljedećih rečenica zaokruži je li ti prihvatljiva ili ne. Ako nije, objasni zašto.

a) Darujte svoje najdraže u našim trgovinama. DA NE

b) Posjetite naše trgovine i darujte jednim od poklon bonova koje nudimo. DA NE

c) Posluženi smo u predvorju. DA NE

d) Služeni su kava i kolači.

DA

NE

e) Djeca su darovana.

DA

NE

f) Djeca su darivana.

DA

NE

C) Ima li razlike u značenju između sljedećih rečenica? Ako da, koja ti je od dvije rečenice prihvatljivija i prirodija?

1)

a) Služeni smo kavom i kolačima.

b) Posluženi smo kavom i kolačima.

2)

a) Gostima su služeni kava i kolači.

b) Gostima su posluženi kava i kolači.

3)

a) Nuđeni smo tortom.

b) Ponuđeni smo tortom.

4)

a) Gostima je nuđena torta.

b) Gostima je ponuđena torta.

Hvala na sudjelovanju!

9. References

- Aissen, J. *Relational Grammar*. <http://ai.ato.ms/MITECS/Entry/aissen.html>. Accessed on: 21 July 2013
- Allerton, D. J. (1978) 'Generating indirect objects in English', *Journal of Linguistics* 14:21-33
- Barić, E. et al. (1997) *Hrvatska gramatika*, Zagreb: Školska knjiga
- Black, C. J. (1999) *A step-by-step introduction to the Government and Binding theory of syntax*, <http://www-01.sil.org/mexico/ling/e002-introgb.pdf>. Accessed on: 23 July 2013
- Bresnan, J. (1982) *The mental representation of grammatical relations*, Cambridge, Mass: MIT Press
- Bolinger, Dwight L. (1968) 'Entailment and the Meaning of Structures', *Glossa* 2: 127
- Chafe, W. L. (1970) *Meaning and the structure of language*, Chicago: University of Chicago Press
- Chomsky, N. (1965) *Aspects of the theory of syntax*, Cambridge, Mass.: MIT Press
- Chomsky, N. (1981) *Lectures on government and binding*, Dordrecht: Foris Publications
- Cook, W. A. (1979). *Case Grammar: Development of the Matrix Model*, Georgetown University Press
- Croatian National Corpus (Hrvatski nacionalni korpus)* (Tadić, M., 2005), Faculty of Philosophy, University of Zagreb

- Daneš, Frantisek. (1966) 'A three-level approach to syntax', in *Travaux linguistiques de Prague vol. 1*, F. Daneš et al. (eds.), Alabama: University of Alabama Press
- Dik, S. C. (1991) 'Functional Grammar', in *Linguistic theory and grammatical description*, F. Droste and J. Joseph (eds.), Amsterdam/Philadelphia: John Benjamins
- Dryer, M. (1986) 'Primary objects, secondary objects and antitativity', *Language* 62:808-845, Linguistic Society of America
- Fillmore, C. (1968) 'The Case for Case', in *Universals in Linguistic Theory*, E. Bach & R. T. Harms (eds.), New York, 1-88
- Gazdar, G., E. Klein, G. Pullum & I. Sag (1985) *Generalized Phrase Structure Grammar*, Cambridge, Mass: Harvard University Press
- Geeraerts, D. & H. Cuyckens (2007), eds. *The Oxford Handbook of Cognitive Linguistics*, Oxford: Oxford University Press
- Goldberg, A. E. (1995) *Constructions*, Chicago: University of Chicago Press
- Halliday, Michael A. K. (1967) "Notes on transitivity and theme in English" part II. *Journal of Linguistics* 3: 204
- Jackendoff, R. (1972) *Semantic interpretation in generative grammar*, Cambridge Mass.: MIT Press
- Jackendoff, R. (1977) *X Syntax: A study of Phrase Structure*. Cambridge, Mass.: MIT Press
- Lambrecht, K. (1994) *Information structure and sentence form*, Cambridge: Cambridge University Press
- Langacker, R. W. (1987) *Foundations of Cognitive Grammar*, vol. I, Stanford: Stanford University Press

- Levin, B. & M. Rappaport Hovav (2002) 'What Alternates in the Dative Alternation?',
handout, RRG Conference, La Rioja, Spain
- Perlmutter, D. (1980) 'Relational Grammar', in *Syntax and Semantics*, vol. XIII: Current
approaches to syntax, E. A. Moravcsik & J. R. Wirth (eds.), New York: Academic
Press, pp. 195-229
- Perlmutter, D., and P. Postal. (1983a) *Towards a universal characterization of passivization*,
in D. Perlmutter (1983), pp. 3-29
- Rosen, C. (1984) *The interface between semantic roles and initial grammatical relations*, in
D. Perlmutter and C. Rosen (1984), pp. 38-77.
- Szabone (2003) *Reconsidering the Dative Shift – A Construction Grammar Approach*,
<http://ganymedes.lib.unideb.hu:8080/dea/bitstream/2437/79661/2/ertekezes.pdf>,
Accessed on: 28 July 2013
- Taylor, J. R. (2002) *Cognitive Grammar*, New York: Oxford University Press
- Van Valin, R. D., Jr. (1993) 'A synopsis of Role and Reference Grammar', in *Advances in
Role and Reference Grammar*, R. D. Van Valin, Jr. (ed.) Amsterdam/Philadelphia:
John Benjamins
- Van Valin, R., Jr. & R. LaPolla (1997) *Syntax: structure, meaning and function*, Cambridge:
Cambridge University Press
- Van Valin, R. D. Jr. (2006) *A Summary of Role and Reference Grammar*,
<http://linguistics.buffalo.edu/people/faculty/vanvalin/rrg/RRGsummary.pdf>.
Accessed on: 29 July 2013

Zovko, I. (2001) *Semantičko-sintaktički odnosi u rečenicama s dvostruko prijelaznim glagolima u engleskom jeziku*, M.A. thesis, Faculty of Philosophy, University of Zagreb

Zovko Dinković, I. (2007) 'Dative Alternation in Croatian', *Suvremena lingvistika* 63: 65–83