

*Int. J. Electrochem. Sci.*, 9 (2014) 8355 - 8366

---

---

**International Journal of  
ELECTROCHEMICAL  
SCIENCE**

[www.electrochemsci.org](http://www.electrochemsci.org)

---

---

## **Influence of Electrolytic Copper Powder Particle Morphology on Electrical Conductivity of Lignocellulose Composites and Formation of Conductive Pathways**

*M. M. Pavlović<sup>1\*</sup>, M. G. Pavlović<sup>2</sup>, V. Čosović<sup>1</sup>, V. Bojanić<sup>3</sup>, N. D. Nikolić<sup>2</sup>, R. Aleksić<sup>4</sup>*

<sup>1</sup>University of Belgrade, ICTM-CMM, 11000 Belgrade, Njegoševa 12, Serbia

<sup>2</sup>University of Belgrade, ICTM-CEH, 11000 Belgrade, Njegoševa 12, Serbia

<sup>3</sup>University of Banja Luka, Agrifaculty, Banja Luka, Republic of Srpska

<sup>4</sup>University of Belgrade, Faculty of Technology and Metallurgy, 11000 Belgrade, Karnegijeva 4, Serbia

\*E-mail: [mpavlovic@tmf.bg.ac.rs](mailto:mpavlovic@tmf.bg.ac.rs)

*Received:* 3 September 2014 / *Accepted:* 17 October 2014 / *Published:* 28 October 2014

---

Composites based on polymers with conductive fillers have been gaining more significant roles in a variety of technological domains and they are getting in the research focus of numerous studies as a part of growing research trend. Galvanostatically produced copper powder with high values of specific area was used as filler for synthesis of electroconductive composite materials prepared by the compression molding of mixtures of lignocellulose and electrochemically deposited copper powder. This article is concerned with characterization of these composites. Analysis of the most significant properties of prepared composites and its components included measurements of electrical conductivity, impedance spectroscopy (IS) behavior and structural and morphological analysis. Volume fraction of the copper powder was varied from 2.0-29.8% (v/v). The significant increase of the electrical conductivity can be observed as the copper powder content reaches the percolation threshold (PT). It was shown that PT depends on both particle shape and type of spatial distribution. IS measurements have shown that particle morphology having pronounced grain boundaries has great effect on appearance of electric conductive layers. The packaging effect and more pronounced interparticulate contact with copper powder particles lead to “movement” of PT, which for the particles <45 μm and highest processing pressure of 27 MPa was 7.2% (v/v). IS response of the composites showed existence of electrical conductive layers, each having different resistivity which increases towards interior of the composite.

---

**Keywords:** impedance spectroscopy, electrolytic copper powder, lignocellulose, composite

## 1. INTRODUCTION

Polymer and fiber reinforced composites play an increasingly important role in commercial, defense, and private sectors. While polymeric systems are well suited for replacing metallic structures with respect to mechanical and processing properties, the electrical properties of polymeric systems are orders of magnitude apart from metals. This transition to polymeric systems occurs concurrently with an increase in utilization of and reliance on digital technologies which are highly sensitive to electromagnetic shielding [1-4].

Traditional metal structures naturally present an electrically conductive and shielding material, as isotropic metals have free valence electrons to facilitate electrical conduction. Polymer matrix composites are naturally not as well suited, consisting of insulating or moderately conducting fibers in an insulating matrix. Thus, the challenge is to find methods of engineering electrical conductivity and shielding properties into polymers and polymer composite systems while preserving fundamental advantages (mechanical, manufacturing, density, cost, etc.) [3-5].

Due to their unique properties and variety of possible applications composite materials play a pivotal role in modern industry and are of great importance for material science in general. By combining insulating polymer with different conductive fillers such as metals and other conductive particles, electrically conductive polymer matrix composites can be obtained. Generally speaking, with the increase of the volume fraction of the conducting filler particles, conductivity of composite increases as the filler particles form the conduction paths through the composite [1-5]. Thus, depending on the amount of the conductive filler that is incorporated into polymer, the obtained composite can retain electrically insulative qualities of polymer or can become electrically semiconductive or conductive. As the volume fraction of the conducting filler reaches a critical value (so-called percolation threshold), an infinite conductive cluster (IC) is formed and, consequently, the composite becomes conductive [4-12]. At low concentrations, below the percolation threshold, the conductivity remains very close to that of the insulating polymer matrix as the electrons still have to travel through the insulating matrix between the conductive filler particles. When a critical volume fraction of the filler, called the percolation threshold, is reached, the conductivity drastically increases by many orders of magnitude. This coincides with the formation of conductive pathways of the filler material forming a three dimensional network, which span the macroscopic sample. The electrons can now predominantly travel along the filler and move directly from one filler to another. Increasing the amount of filler material further, levels off the conductivity, the maximum conductivity of the composite [4-12].

In addition to the conductivity control electroconducting polymer composites have further advantages of lower cost, ease of manufacture, reduced weight, high flexibility, corrosion resistance and mechanical shock absorption ability which makes them rather interesting for many fields of engineering [4-6,13-16].

Numerous studies can be found in literature related to the influence of the type of polymer matrix and filler on the electrical properties of the composites [4-7,17-20]. The studies suggest that the particle size and shape, the nature of the contact between the conductive filler elements, volume

fraction and spatial arrangement of the conducting filler particles all have significant influence on the conductivity of filled polymers [7-12].

Furthermore, increasing environmental awareness combined with increase in crude oil price has opened investigations of eco-friendly and sustainable alternatives to fossil fuel based synthetic polymers and stirred up recent investigations towards biopolymers i.e. biodegradable polymers [13-20]. Accordingly, a large number of these biodegradable polymers are currently commercially available [21].

Biodegradable polymers like lignocellulose (LC) represent a good alternative and energy efficient replacement of polymers from fossil fuels. Lignocellulosic biomass is essentially a nonstarch, fibrous part of plant material which is an attractive resource since it is renewable and very abundant [1-3,21,22]. General route for the preparation of LC is via physical treatment that utilizes high mechanical shear force to generate bundles of microfibrils i.e. cellulose microfibril or microfibrillated cellulose with sizes ranging from several nanometers to micrometers in diameter [4-5,7]. These lignocellulose-based fibers possess a number of interesting mechanical and physical properties. Nevertheless, owing to genetic and environmental influences and their interactions [18] structural and chemical composition of the lignocellulosic feedstock is highly variable. In general, chemical composition of lignocellulosic feedstock has the dominant influence on properties of this biodegradable polymer and its composites [19].

Conducting polymer composites with metal fillers have found uses as conducting adhesives in electronics packaging, underfill for flip chips, in electromagnetic shielding of computers and electronic equipment, cold solders, switching devices, static charge dissipating materials and devices for surge protection [23-25]. Also they found numerous technological applications as photothermal optical recorders, chemical and electrochemical catalysts, self regulating heater, direction finding antennas, chemical detecting sensors used in electronic noses and adsorbents [3,26-31].

In the present study electroconductive composite material was prepared by the compression molding of mixtures of LC and electrochemically deposited copper powder. The starting components and the prepared composites with volume fraction of copper powder in range 2.0-29.8% (v/v) were analyzed in terms of their most significant properties. The analysis included measurements of electrical conductivity, structural investigations and impedance spectroscopy (IS) characterization.

Materials science has found very useful companion in the form of impedance spectroscopy (IS) and its application of materials characterization in the last years. IS is becoming major method of choice for characterizing the electrical behavior of systems. It should be emphasized that the overall system behavior is determined by a number of strongly coupled processes, each proceeding at a different rate [7,32]. Impedance spectroscopy is a relatively new tool, but very powerful when it comes to investigation of the dynamics of bound or mobile charges in the bulk or interfacial regions. Materials investigated can be any kind of solid or liquid. These materials include, but are not limited to ionic, semiconducting, mixed electronic-ionic, and even insulators (dielectrics), solid electrolyte materials (amorphous, polycrystalline and single crystal), solid metallic electrodes, fused salts, aqueous electrolytes and composite materials [32].

## 2. EXPERIMENTAL PART

Copper powder was galvanostatically produced as stated in [33-35]. The powder had large specific area and distinct dendritic morphology. The parameters of electrolysis, deposition times and experimental setup were the same as stated in [4-5,7], i.e. electrolyte contained  $140 \text{ g/dm}^3$  sulfuric acid and  $15 \text{ g/dm}^3$  copper ions, and electrolyte temperature  $(50 \pm 2)^\circ\text{C}$ . The deposition current density was  $3600 \text{ A/m}^2$  and the deposition (brush removal) time was 15 min. The wet powder was washed several times with a large amount of demineralized water until the powder was free from traces of acid, at room temperature, because the acid promotes rapid oxidation of the powder during drying. Obtained copper powder was washed afterwards with sodium soap SAP G-30 solution to protect the powder against subsequent oxidation. After drying in the tunnel furnaces at  $110 - 120^\circ\text{C}$  in a controlled nitrogen atmosphere, the copper powder was sieved through a mesh with  $45\mu\text{m}$  openings.

Celgran<sup>®</sup> C fraction of the corn cob produced by Maize Research Institute "Zemun Polje" was used as a source of lignocellulose. It was milled and then sieved, with particle sizes below  $45 \mu\text{m}$ . Lignocellulose prepared and obtained in this manner was used as natural polymer matrix.

Investigated composites of lignocellulose matrix filled with copper powder were prepared with filler contents in the range  $2.0\% \text{ (v/v)} - 29.8\% \text{ (v/v)}$ , while pure lignocellulose samples were prepared as reference materials. Thoroughly homogenized composite powder mixtures were pressed into 16 mm diameter pellets under pressures of 10, 20 and 27 MPa. at ambient temperature ( $t = 25^\circ\text{C}$ )

Impedance spectroscopy (IS) experiments were performed in potentiostatic mode on all prepared composites. Instrumentation involved Bio-Logic<sup>®</sup> SAS Instrument, model SP-200, guided by EC-Lab<sup>®</sup> software. Samples were put between two metal plates and they responded to the potential input sinusoidal signal of  $\pm 10\text{mV}$  (rms) amplitude. Geometry of the instrument contacts used is such that it minimizes edge effects thus it can be assumed that they do not exist. Experimental IS data were fitted by ZView<sup>®</sup> software [36].

Sample thickness (necessary for the calculation of conductivity) was determined using micrometer, to an accuracy of 0.01 mm. Several thickness measurements were taken per sample and then averaged.

The morphology of the electrochemically deposited copper powder and lignocellulose, as well as composite inner surface was investigated by scanning electron microscopy using a VEGA TS 5130MM microscope (Tescan).

## 3. RESULTS AND DISCUSSION

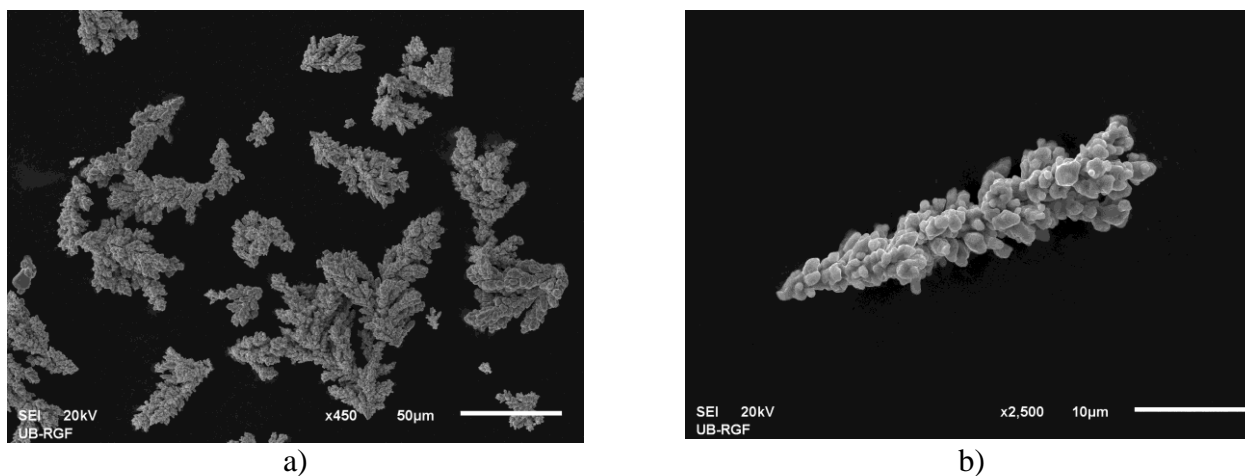
As previously mentioned, the morphology of the conductive filler elements and matrix strongly influences the conductivity of the composites. The conductivity of filled polymers is depends on particle size, shape of the conductive particle filler, apparent density, specific area of the filler particles and nature of the contact between the conductive filler elements. This was shown in [4-5,7] where the copper powder was galvanostatically produced since it should have distinct dendritic morphology and large specific area. Copper powder produced in the same manner was used to alter the electrical

properties of lignocellulose polymer. The apparent density of electrodeposited copper powder was  $0.556 \text{ g/cm}^3$ , and the results of quantitative microstructural analysis for the sieved powders are shown in Table 1.

**Table 1.** Parameters which characterize sieved fraction ( $\leq 45\mu\text{m}$ ) of electrolytic copper powder deposited galvanostatically at current density of  $3600 \text{ A/m}^2$

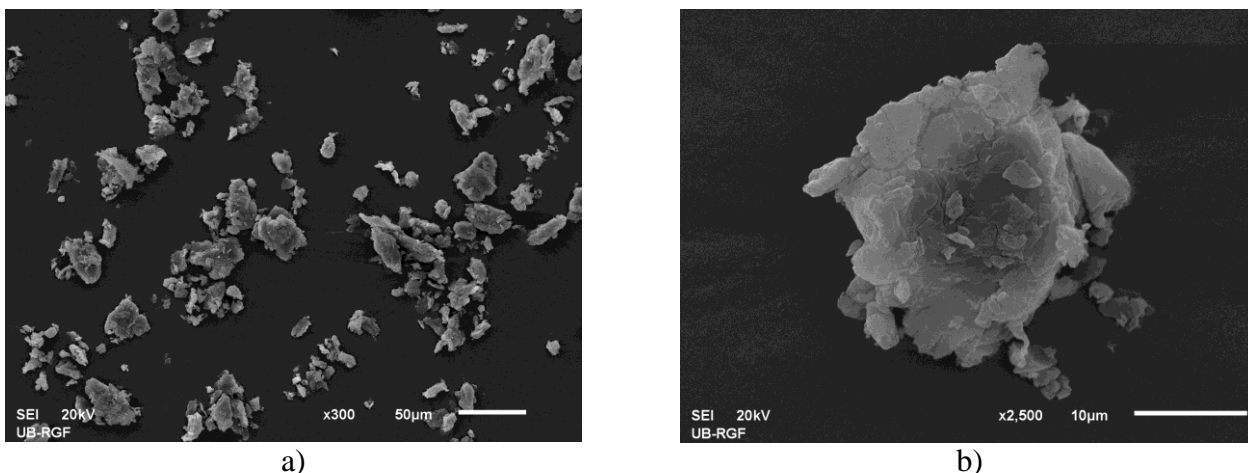
	Max	Min	Mean
$A$ (area) ( $\mu\text{m}^2$ )	578.32	5.71	91.76
$L_p$ (perimeter) ( $\mu\text{m}$ )	181.34	0.98	57.82
$D_{\text{max}}$ ( $\mu\text{m}$ )	50.47	2.91	28.34
$D_{\text{min}}$ ( $\mu\text{m}$ )	12.94	0.98	6.81
$f_A$ (form area)	1.00	0.37	0.75
$f_L$ (form perimeter)	0.87	0.12	0.50
$f_w$ (a shape factor which gives a minimum value of unity for a circle)	1.00	0.73	0.89
$f_R$ (roundness)	3.99	1.22	2.12

The obtained results of the used copper powder show that the powder had very high surface area. The shape factor for roundness of the particles,  $f_R$ , shows very distinct features for high porosity and dendritic particles with large specific areas. Primary and secondary dendrite arms are well developed. This feature can be seen on Figure 1b, which shows typical copper powder particle used in composite preparation, while Figure 1a shows general view of the powder particles. It can be seen that copper powder particles are not rounded, pronounced dendrite branching can be observed as well as high specific area for each particle. Hence, this powder is able to form more interparticle contacts between itself which is lowering the percolation threshold.



**Figure 1.** SEM photomicrographs of copper powder particles obtained in constant current deposition. a) general view b) typical powder particle.

Figure 2a shows SEM photomicrographs of the used lignocellulose and Figure 2b shows its layered structure.

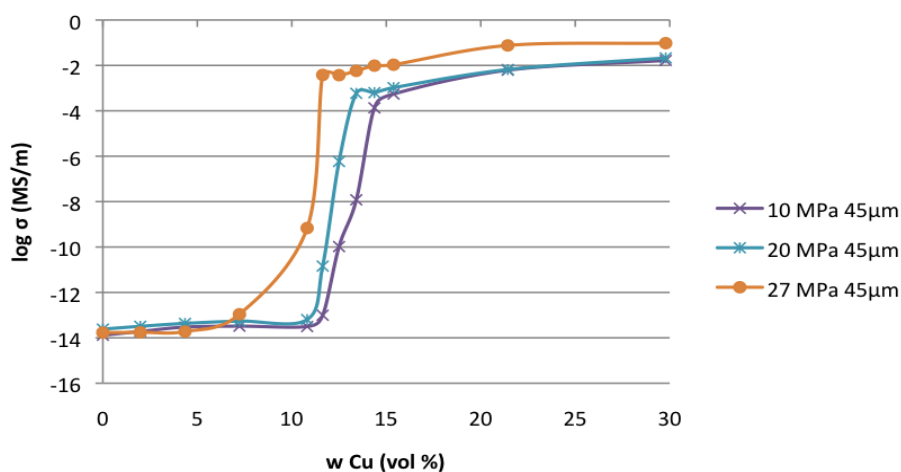


**Figure 2.** SEM photomicrographs lignocellulose matrix used in composite preparation. a) general view b) typical particle view (layered structure).

The electrical conductivity of composites as a function of filler content for all the samples was measured and calculated from impedance characteristics of a composite using Equation (1):

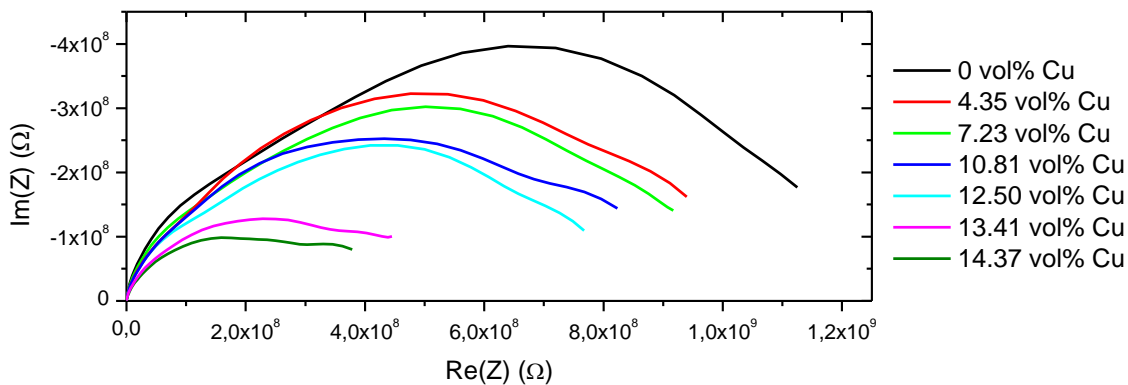
$$\sigma = \frac{1}{\sum_1^7 R_i} \cdot \frac{l}{S} \tag{1}$$

where  $\sigma$  is electrical conductivity,  $R_i$  – resistivity of a layer in equivalent circuit,  $l$  – length and  $S$  – cross-section area of the sample. Measurements of electrical conductivity as a function of filler content are presented in Figure 3.

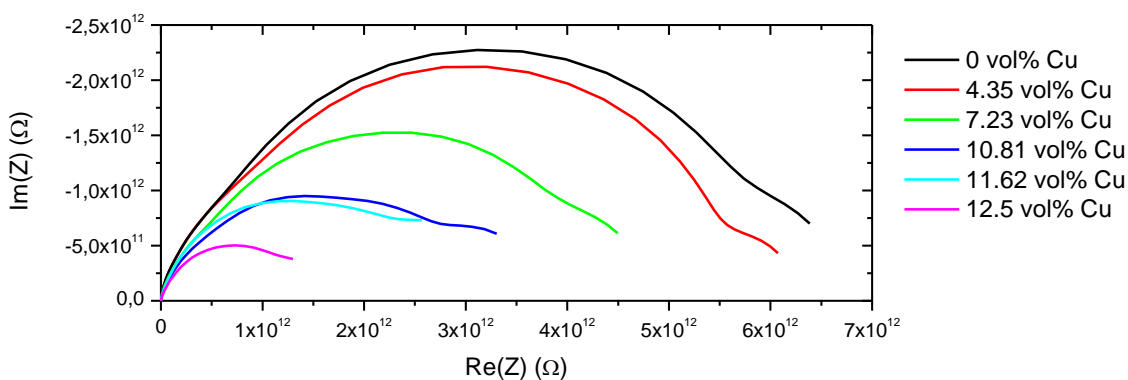


**Figure 3.** Comparison of electrical conductivities, as a function of filler content, of lignocellulose composites filled with copper powder under different processing pressures.

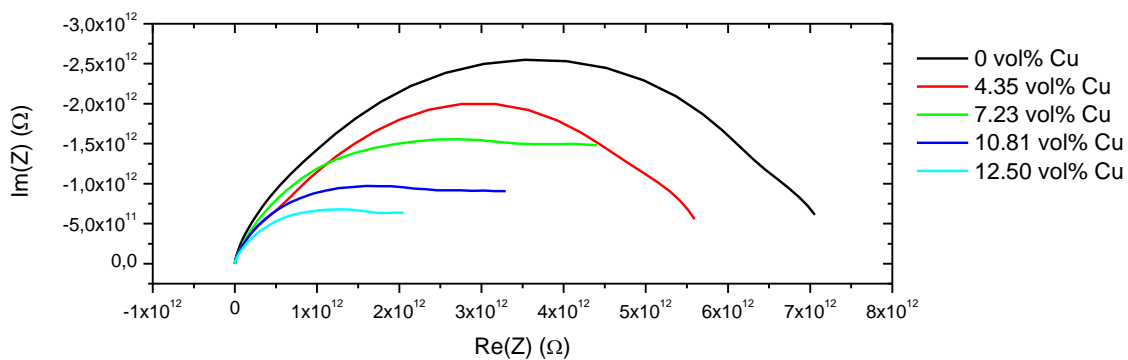
Results of the percolation threshold measured from the experimental data of impedance spectroscopy were obtained from the maximum of the conductivity derivative as a function of filler volume fraction. It should be noticed that they are in good agreement with previously published results [4-5,7].



a)



b)



c)

**Figure 4.** Impedance measurements results showing electric resistance distribution throughout the composite layer in the complex plane for the samples prepared under pressures of a) 10MPa, b) 20 MPa and c) 27 MPa.

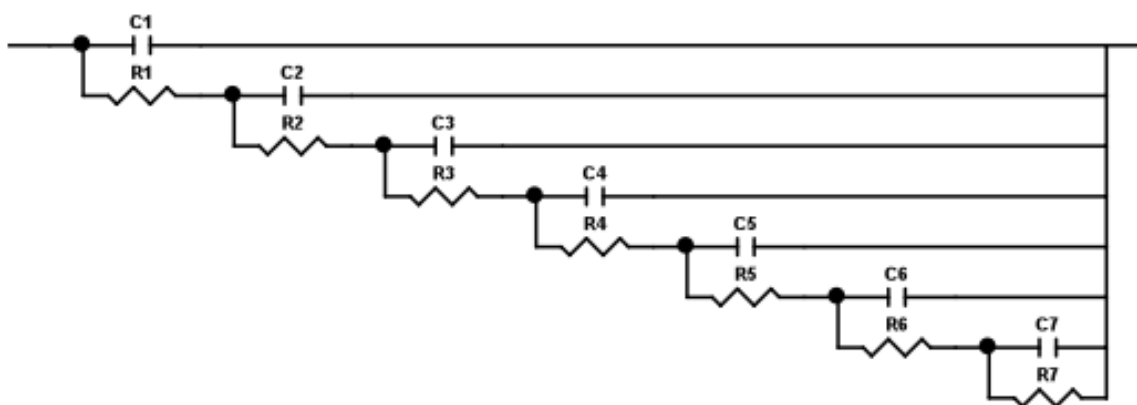
Physical properties like mechanical, crystallographic, compositional, and, particularly, electrical change drastically at an interface between two phases in the composite. Heterogeneous charge distributions (polarizations) reduce the overall electrical conductivity of a system. The morphology of used copper powder (Figure 1) shows that greater interparticulate contact of smaller particles with high values of specific area move percolation threshold towards lower filler content.

Impedance data were simulated by equivalent electrical circuits based on transmission line model [37]. The equivalent electrical circuits which gave the best fitting results (chi-squared based on modulus calculated was below 0.001, with relative error of the parameter values of the elements not exceeding 20%) are schematically presented in Figure 5, while their IS responses are given by lines in Figure 4. A transmission line circuit of the seventh order (i.e., circuit consists of seven transmission branches, Figure 5) best describes the IS behavior.

Typical behavior for nonconductive, at percolation threshold and semiconductive samples for all the composites can be observed. There is great change in the shape of the curve at percolation threshold, and the ohmic resistance is lowering by several orders of magnitude.

These transmission line circuits of the composites represent distributed  $RC$  time constants as a measure of accessibility of different parts of internal surface of a layer. It should be mentioned that the resistance of the composites increases due to the increasing contribution of the part of internal surface of polymer matrix as frequency decreases. In the certain frequency range, capacitance and resistance values are similar.

Number of resistors related to layer resistance,  $R_n$ , from Figure 5, in  $n$  transmission branches depends on morphology of filler and matrix, particle size and porosity and they are related to conductivity in the inner layers.

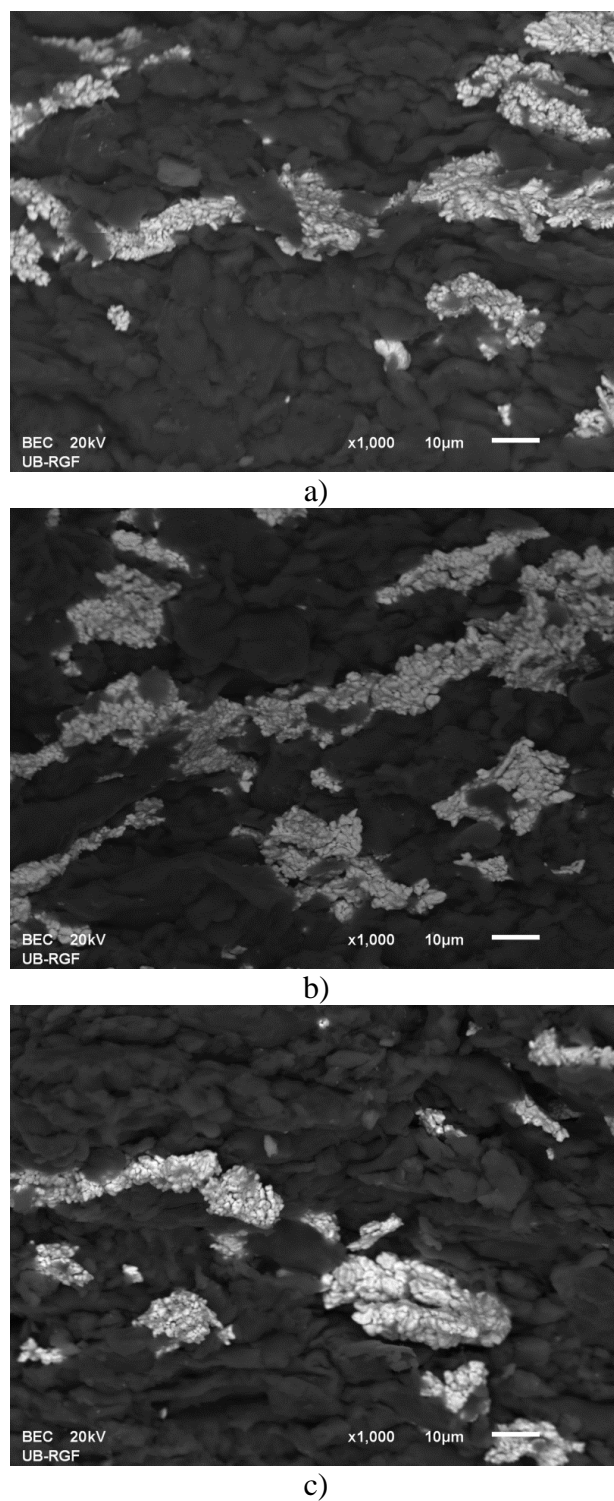


**Figure 5.** The most suitable equivalent electrical circuits used to simulate IS data of LC-Cu composites from Figure 4 [7].

Due to the pronounced interparticle contact with smaller particles having high values of specific area and to the packaging effect, the percolation threshold has appears at lower filler content. Conductive pathways at percolation threshold can be observed on Figure 6. The conductivity of the composite is obtained through conductive pathways of the filler that form in the composites. These



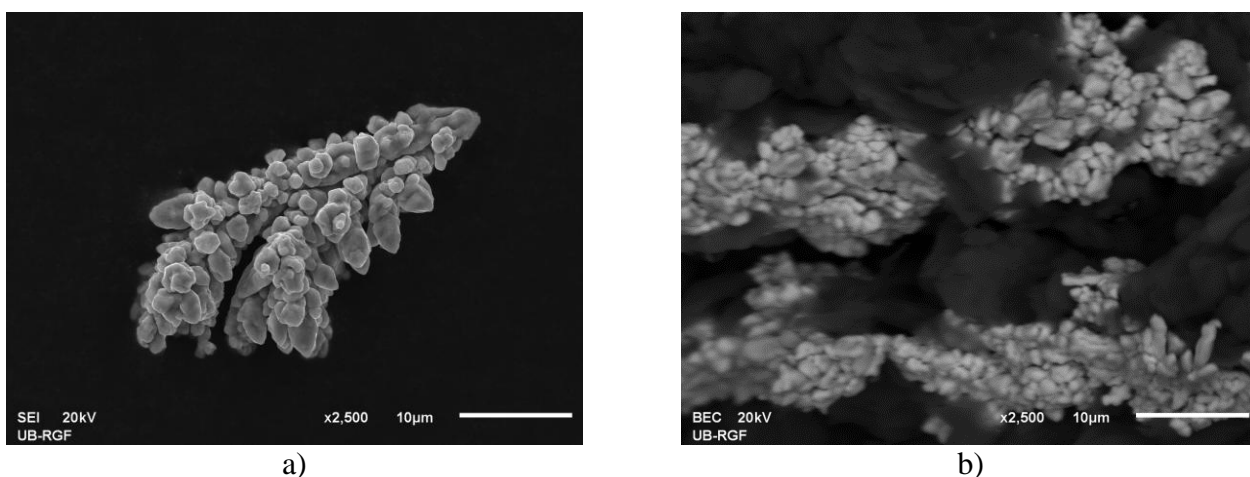
pathways are formed in 3D in a pure random order. SEM images of the inner structure of the composites are prepared after composite preparation and its braking.



**Figure 6.** SEM images of the conductive pathways in the composites at percolation threshold. Composites are prepared under a) 10 MPa, b) 20 MPa and c) 27 MPa. All photographs are prepared at magnification x350.

It should be mentioned that copper powder filler was sieved through mesh with the openings of 45  $\mu\text{m}$ , and the conductive pathways are at much larger scale which can be observed on Figure 6 [38].

There is an influence of the pressure on electrical conductivity of the composites. For the pressure of 10 MPa the percolation threshold was lowered to 12.5% (v/v), for 20 MPa it was 11.6% (v.v), and for 27 MPa was 7.2% (v/v) which is the difference of 5.8% (v/v) in filler content. At higher pressures less filler is needed to form conductive pathways through a composite. However, at the pressure of 27 MPa it can be observed that the starting surface features of electrodeposited copper powder is a bit deformed, although it is still forming conductive pathways (Figure 7). Further tests, at higher pressures will show the future impact of increased pressure on composite conductivity, and whether it starts to decrease after certain point.



**Figure 7.** SEM images of the a) electrodeposited copper powder used as a filler and b) copper powder in the composite prepared at 27 MPa. Magnification x2500.

Flandin et al. [22] state that typical values of 20–40% (v/v) for percolation threshold for spherical filler particles. Hence, electrodeposited copper powder particles represent excellent choice as conductive composite fillers.

#### 4. CONCLUSIONS

Experimental study about the effects of particle morphology of electrodeposited copper powder on the electrical conductivity of lignocellulose composites filled with this powder and formation of conductive pathways has been shown in this article. It has been shown that particle shape of copper powder with very high surface area, specific morphology and pronounced dendrite branching plays significant role on electrical conductivity of the prepared samples. Electrical conductivity was calculated from the results of impedance spectroscopy measurements and it is in agreement with previously published results [7-9]. Layered electrical conductivity through the samples was found, where the resistance of the inner layers is guiding process of the overall resistance of the composite.

Grain boundary plays significant effect. The response is elongated coupled resistance with constant impedance “tail” towards lower frequencies. It can be pointed out that resistance increases due to the increasing contribution of the part of internal surface of polymer matrix as frequency decreases. Polycrystallinity, high surface area, greater number of interparticle contacts and grain boundary effect of the copper powder are key factors influencing percolation threshold in the LC-Cu composites. There is an influence of pressure on the composites electrical conductivity. The conductivity increases for lower filler content as the pressure increases. However there is a change in filler morphology at higher pressures, and more research is needed to investigate the influence of even higher pressures on the percolation threshold. This research has undeniably shown that particle morphology of galvanostatically obtained copper powder and lignocellulose matrix and pressure play significant role in electrical conductivity of the composites.

#### ACKNOWLEDGEMENT

This work was financially supported by Ministry of Education, Science and Technological Development of the Republic of Serbia under the research projects: ON172037 and ON172046.

#### References

1. L. Averous and F. Le Digabel, *Carbohydrate Polymers*, 66 (4) (2006) 480
2. M. Ioelovich, *BioResources*; 3 (4) (2008) 1403
3. V.H. Poblete, M.P. Alvarez and V.M. Fuenzalida, *Polymer Composites*, 30 (2009) 328
4. M.M. Pavlović, V. Čosović, M.G. Pavlović, N. Talijan and V. Bojanić, *Int. J. Electrochem. Sci.*, 6 (2011) 3812
5. M.M. Pavlović, V. Čosović, M.G. Pavlović, V. Bojanić, N.D. Nikolić and R. Aleksic, *Int. J. Electrochem. Sci.*, 7 (2012) 8883
6. G. Pinto, A.K. Maaroufi, R. Benavente and J.M. Perena, *Polym. Compos.*, 32 (2011) 193
7. M.M. Pavlović, M.G. Pavlović, V. Panić, N. Talijan, Lj. Vasiljević, M.V. Tomić, *Int. J. Electrochem. Sci.*, 7 (2012) 8894
8. E.P. Mamunya, V.V. Davydenko, P. Pissis and E.V. Lebedev, *Euro. Polym. J.*, 38 (2002) 1887
9. Q. Xue, *Euro. Polym. J.*, 40 (2004) 323
10. D. Stauffer and A. Aharony, *Introduction to Percolation Theory*, 2nd ed., Taylor and Francis, London (1992)
11. E.P. Mamunya, V.V. Davydenko and E.V. Lebedev, *Compos. Interfaces*, 4 (1997) 169
12. E.P. Mamunya, V.V. Davydenko and E.V. Lebedev, *Polym. Compos.*, 16 (1995) 319
13. M. M. Treacy, T.W. Ebbesen, J. M. Gibson, *Nature*, 381 (1996) 678.
14. S. K. Bhattacharya, editor, *Metal-filled polymers (properties and applications)*, Marcel Dekker, New-York (1986)
15. E.A. Stefanescu, C. Daranga and C. Stefanescu, *Materials*, 2 (2009) 2095
16. C. Singh, V. Sharma, P. Kr Naik, V. Khandelwal and H. Singh, *Digest Journal of Nanomaterials and Biostructures*, 6 (2) (2011) 535
17. S. Nenkova, P. Vele, M. Dragnevskaa, D. Nikolova and K. Dimitrov, *Bioresources*, 6 (3) (2011) 2356
18. M. A. Cohen Stuart et al., *Nature Materials*, 9 (2010) 101
19. P. N. Vele, S. K. Nenkova, M. N. Kulevski, *Bulgarian Chemical Communications*, 44 (2) (2012) 164

20. V. Bojanić, M.G. Pavlović, *New Technology for the Synthesis of New Materials Based on Cellulose and Sorption of Noble Metals, Noble Metals*, S. Yen-Hsun (Ed.), ISBN 978-953-307-898-4, InTech (2012), pp.179-206
21. Q. Xue, *Euro. Polym. J.*, 40 (2004) 323
22. L. Flandin, A. Chang, S. Nazarenko, A. Hiltner and E.J. Baer, *J. Appl. Polymer. Sci.*, 76 (2000) 894
23. C.N. Hamelinck, G.V. Hooijdonk, and A.P. Faaij, *Biomass and Bioenergy*, 28 (2005) 384
24. M.L. Sham and J.K. Kim, *Composites Part A: Appl. Sci. Manuf.*, 35 (2004) 537
25. J. Delmonte, *Metal/Polymer Composites*, Van Nostrand Reinhold, New York (1990)
26. M. Thakur, *Macromolecules*, 21 (1988) 661
27. P. Lafuente, A. Fontecha, J.M. Diaz and A.E. Munoz, *Rev. Plast. Mod.*, 447 (1993) 257
28. V.E. Gul, *Structure and Properties of Conducting Polymer Composites*, VSP: New York (1996)
29. B.C. Munoz, G. Steinthal and S. Sunshine, *Sens. Rev.*, 19 (1999) 300
30. J.B. Patel and P.Sudhakar, *EJEAFChe*, 7 (14) (2008) 2735
31. S. Kirkpatrick, *Rev. Mod. Phys.*, 45 (1973) 574
32. E. Barsoukov, J. R. Macdonald, editors, *Impedance Spectroscopy: Theory, Experiment, and Applications*, John Wiley & Sons, Hoboken, New Jersey (2005)
33. K.I. Popov and M.G. Pavlović, in *Modern Aspects of Electrochemistry*, Electrodeposition of metal powders with controlled particle grain size and morphology, B.E. Conway, J.O'M. Bockris and R.E. White, Eds., Vol. 24, Plenum, New York, (1993) 299–391
34. M.G. Pavlović, K.I. Popov and E.R. Stojilković, *Bulletin of Electrochemistry*, 14 (1998) 211
35. M.G. Pavlović, Lj.J. Pavlović, V.M. Maksimović, N.D. Nikolić and K.I. Popov, *Int. J. Electrochem. Sci.*, 5 (2010) 1862
36. V.V. Panić, R.M. Stevanović, V.M. Jovanović, A.B. Dekanski, *J. Pow. Sour.*, 181 (2008) 186
37. B. Conway, *Electrochemical Supercapacitors—Scientific Fundamentals and Technological Applications*, Plenum Publishers, New York, (1999)
38. M.M. Pavlović, Ma.M. Pavlović, V. Čosović, M. Gligorić, V. Bojanić, *16. YUCORR*, Proceedings, CD, ISBN 978-86-82343-21-9, (2014) 284-293.