

## Wavelet Analysis and Radial Basis Function Neural Network Based Stability Status Prediction Scheme

Emmanuel Asuming Frimpong<sup>1\*</sup>, Philip Yaw Okyere<sup>1</sup>, Johnson Asumadu<sup>2</sup>

<sup>1</sup>Department of Electrical and Electronic Engineering,

Kwame Nkrumah University of Science and Technology, Ghana

<sup>2</sup>Department of Electrical and Computer Engineering, Western Michigan University, United States

\*Corresponding author, e-mail: [eafrimpong.soe@knust.edu.gh](mailto:eafrimpong.soe@knust.edu.gh)

**Abstract**— This paper presents a technique for predicting the transient stability status of a power system. Bus voltages of system generators are used as input parameter. The bus voltages are processed using wavelet transform. Daubechies 8 mother wavelet is employed to extract wavelet entropy of detail 1 coefficients. The sum of wavelet entropies is used as input to a trained radial basis function neural network which predicts the transient stability status. The IEEE 39-bus test system was used to validate the effectiveness and applicability of the technique. The technique is simple to apply and can be implemented in real-time. The prediction accuracy was found to be 86.5% for 200 test cases.

*Keywords* : Radial basis function, Transient analysis and Wavelet transform

### 1. Introduction

The occurrence of severe disturbances such as three-phase faults on transmission lines endangers the stability of power systems. Severe disturbances could cause large separation of the rotor angles between individual generators or groups of generators. This will eventually result in loss of synchronism between generators and groups of generators or between neighbouring utility systems. The loss of synchronism between individual generators or generator groups may lead to equipment damage and power blackouts [1]. An example of this is the August, 2003 blackouts that occurred in United States and Canada [2]. To avoid the harmful effects of loss of synchronism conditions, asynchronous generators need to be quickly isolated and transient stability improvement techniques such as controlled islanding activated [3].

Several methods have been proposed to address loss of synchronism problems. The methods include the development of schemes for detecting and predicting transient instability [3 - 8]. The techniques in literature have not fully addressed the issue of predicting transient instability. For instance, a transient instability prediction scheme needs to operate on-line, act speedily, have high accuracy, must be robust and

simple to implement. These desired features are yet to be found in a single scheme. Therefore, there is the need for further research.

This paper proposes a wavelet analysis and radial basis function neural network (RBFNN) based transient stability status prediction scheme using post-fault generator bus voltages as input parameter. The scheme applies the Daubechies 8 (db8) mother wavelet to decompose generator bus voltages and extracts the wavelet entropies contained in level 1 detail coefficients. The obtained entropies are then summed and used as input to the RBFNN which indicates the system's stability status. The proposed scheme operates on-line and provides speedy response. It is robust and can also be easily implemented. The prediction accuracy is also high.

### 2. Generator Bus Voltage as Input Parameter

Figures 1 and 2 show post-fault voltage trajectories for three-phase bus fault on bus 14 of the test system (described in the Section 6 with varying fault durations. These curves were obtained through dynamic simulation using the Power System Simulator for Engineers (PSS<sup>®</sup>E) software. The curves in Figure 1 represent the

Received date 2018-06-28, Revised date:2018-10-10, Accepted date: 2018-07-25

<https://doi.org/10.25077/jnte.v7n3.559.2018>

This work is licensed under a [Creative Commons Attribution-ShareAlike 4.0 International License](https://creativecommons.org/licenses/by-sa/4.0/).

voltage trajectories of the ten generator buses for a three-phase fault applied at time  $t = 0.1s$  and cleared at time  $t = 0.2s$  by tripping the faulted bus. The system was stable for this fault condition.

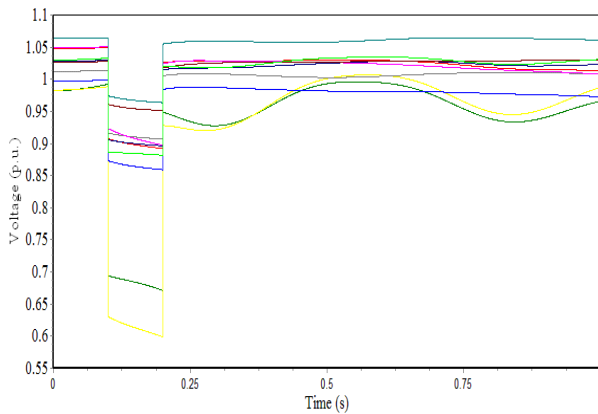

Figure 1. Bus voltage waveforms for a transient stable case.

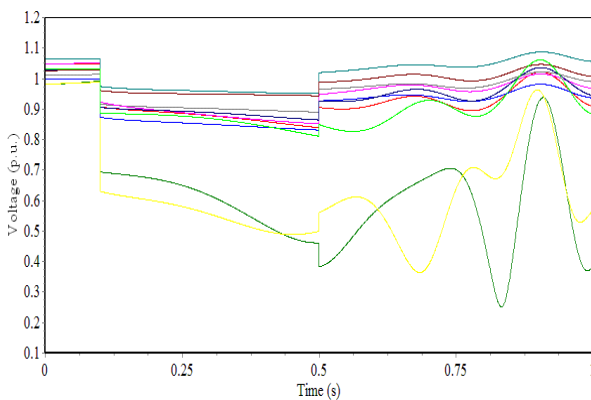

Figure 2. Bus voltage waveforms for a transient unstable case

On the other hand, figure 2 shows the post-fault voltage trajectories for the ten generators for a three-phase fault which lasted for 0.4 seconds. For this fault case, there was transient instability. Comparing the two figures, some significant differences can be observed. For the stable case, all the post-fault voltage trajectories tend to remain somewhat flat. However, for the case resulting in instability, there are significant voltage swings. This difference can be potentially exploited to predict post-fault system stability or instability [8].

The successful use of post-fault bus voltages to predict transient stability or otherwise largely depends on the signal processing approach adopted as well as decision making tool used. In this work, wavelet analysis and RBFNN were

employed for signal processing and decision making respectively.

### 3. Wavelet Analysis

Wavelet analysis is a mathematical tool used to analyze localized variations of power system variables within a time series. It enables the determination of the dominant modes of variability as well as how they vary in time. Wavelet analysis is carried out using mother wavelets. Daubechies wavelets are the most widely used mother wavelets in power system studies [9]. Among the Daubechies mother wavelets, Daubechies 4 and Daubechies 8 are found to be most suitable for the analysis of power system transients [10]. The Daubechies 8 (db8) mother wavelet was used in this work. In the field of engineering, wavelet analysis is popularly done using discrete wavelet transform (DWT) [11].

The breaking up of a signal using DWT results in one approximate coefficient and a number of detail coefficients. Detail coefficients have been found to contain useful information. One useful information that can be extracted from detail coefficients is wavelet entropy. Wavelet entropy (WE) is a measure of the degree of disorder of a signal. Therefore, it can provide valuable characteristics about a signal [12, 13]. The wavelet entropy,  $E_n$  of a detail coefficient,  $d_n$ , is given by [12, 13]:

$$E_n = |d_n|^2 \quad (1)$$

It is expected that the WEs of detail coefficients for a stable condition will be less than those for an unstable condition. This work applies Daubechies 8 mother wavelet to analyse post-fault voltage waveforms and extracts wavelet entropy of detail coefficients for the prediction of transient stability status.

### 4. Radial basis function neural network (RBFNN)

RBFNN is one of the commonly used neural networks. It has remarkable ability to derive meaning from complicated or imprecise data [14]. It was therefore used in this study as a decision tool.

The output  $Y_i$  of a radial basis neuron is given as [15]:

$$Y_i = R(\|w_i \cdot x\|w_{i0}) \quad (2)$$

where  $x$  is the input vector (signal),  $w_i$  is the weight vector of radial neuron  $i$ ,  $\|w_i \cdot x\|$  is the Euclidean distance between the two vectors,  $w_{i0}$  is the bias weight of neuron  $i$ , and  $R$  is a Gaussian function. In MATLAB (the tool used for signal processing in this work),  $R$  is given as:

$$R(n) = e^{-n^2} \quad (3)$$

The output  $O_j$  of neuron  $j$  in the output layer is given as:

$$O_j = Y_i w_{ij} + w_{j0} \quad (4)$$

where  $w_{ij}$  is the weight of the connection between neuron  $i$  in the input layer and neuron  $j$  in the output layer, and  $w_{j0}$  is the bias weight of neuron  $j$ .

### 5. Proposed Technique

Figure 3 shows a flow chart of the proposed stability status prediction technique.

The scheme is triggered after relay operation in response to a disturbance. The operating procedure is outlined as follows:

- (i) Sample bus voltages of all generators using a rate of 32 samples per cycle. This sampling rate is typical of existing numerical relays [16]. At this stage, phasor measurement units are required to aid in the transfer of all data to a centralized location for processing. For each bus voltage sampled, only the first eight samples subdivided into two sets  $S_{1n}$  and  $S_{2n}$ , are required by the proposed algorithm.  $S_{1n}$  and  $S_{2n}$ , are obtained as follows:

$$S_{1n} = \{V_{1n}, V_{2n}, V_{3n}, V_{4n}\} \quad (5)$$

$$S_{2n} = \{V_{5n}, V_{6n}, V_{7n}, V_{8n}\} \quad (6)$$

where  $n = 1, 2, 3, \dots, N$  and  $N$  is the number of generators.

- (ii) For each sample set, the following is done:
  - (a) A 3-level wavelet decomposition is performed using the db8 mother wavelet (this results in three detail coefficients and one approximate coefficient).
  - (b) The

wavelet entropy of detail 1 coefficient is extracted.

- (iii) Obtain the wavelet entropy,  $E_{1n}$ , for detail 1 coefficient of each  $S_{1n}$  sample set and sum all  $E_{1n}$  values to obtain  $E_{1T}$ .

$$E_{1T} = \sum_{n=1}^N E_{1n} \quad (7)$$

- (iv) Also obtain the wavelet entropy,  $E_{2n}$ , of detail 1 coefficient of each  $S_{2n}$  sample set and sum all  $E_{2n}$  values to obtain  $E_{2T}$ .

$$E_{2T} = \sum_{n=1}^N E_{2n} \quad (8)$$

- (v) Separately feed  $E_{1T}$  and  $E_{2T}$  into RBFNN. For each input, the RBFNN gives an output of '0' or '1'. An output set of {0, 0} indicates transient stability while outputs sets of {1, 1}, {1,0} or {0,1} indicate transient instability.

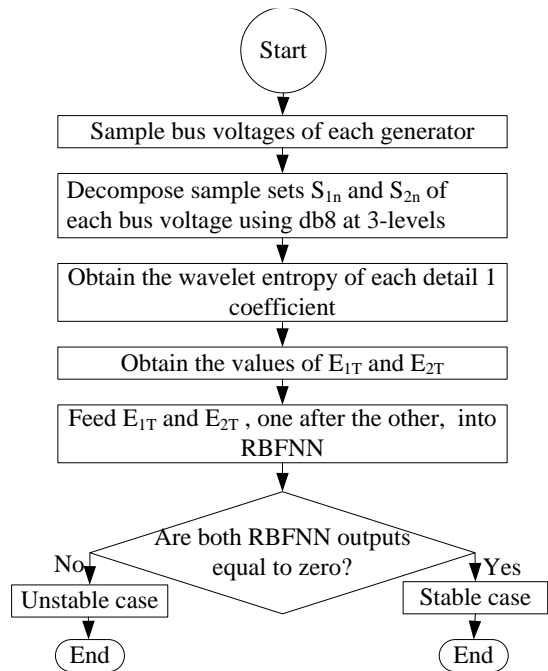

Figure 3. Flowchart of proposed technique

### 6. Used Test System

The IEEE 39-bus test system was used to develop and test the proposed scheme. It is shown as figure 4. This system is a standard

system extensively used for stability studies [3, 7, 8]. It is made up of 10 generators (G1-G10). Generator 1 (G1) represents a large system. The system data for modelling was obtained from [17]. Modelling and simulation was done using the PSS@E software

Two hundred and four (204) line and bus faults were simulated. In the simulations, loading condition, fault type as well as location and duration were varied. This was done to ensure thorough testing. The simulations were done such that 50% resulted in transient stability while the remaining 50% also lead to instability. Data from only four cases was used to train the RBFNN. This represents only 1.96% of the total data generated. Compared with other training cases in literature [8], this is very low. A low volume of training data allows for easy application of scheme to large systems.

### 7. Results and Analysis

The technique was tested with data from 200 simulation cases comprising 100 transient stable and 100 transient unstable cases. Correct prediction was obtained for 91 out of the 100 stable cases. Out of the 100 transient unstable case presented, the technique successfully predicted 82 cases. Overall, the prediction accuracy was found to be 86.5%.

A step by step approach to predict the stability status for two fault cases is presented to demonstrate the operation of the proposed technique. Table 1 and table 2 show  $E_{1n}$  and  $E_{2n}$  values for cases of transient stability and transient instability respectively. This data resulted from three-phase faults on the line between buses 16 and 21 such that there was stability (due to short fault duration) and later instability (due to prolonged fault duration). The table also shows the corresponding  $E_{1T}$  and  $E_{2T}$  values.

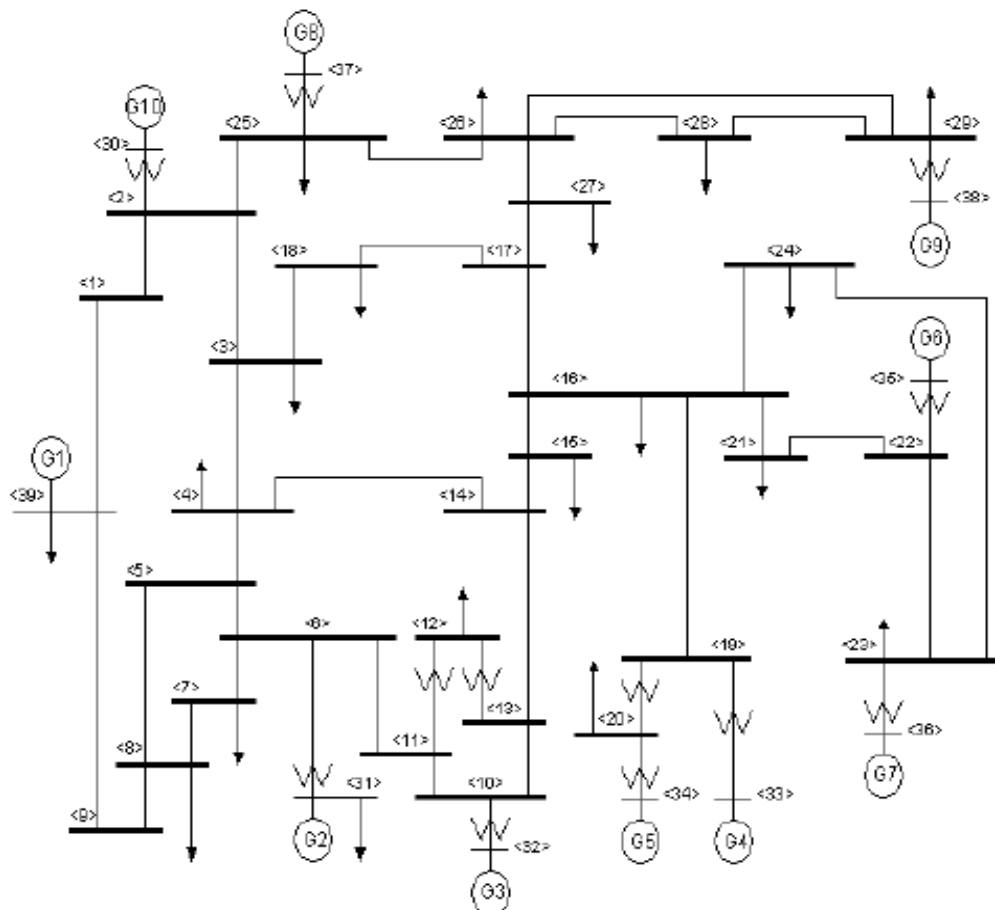

Figure 4. Used test system

Table 1.  $E_{1n}$  and  $E_{2n}$  values for stable case.

Gen.	Stable case	
	$E_{1n} (\times 10^{-7})$	$E_{2n} (\times 10^{-7})$
G1	0.009	0.001
G2	0.111	0.010
G3	0.061	0.012
G4	0.131	0.049
G5	0.063	0.027
G6	0.287	0.260
G7	0.057	0.042
G8	0.021	0.014
G9	0.037	0.054
G10	0.036	0.019
	$E_{1T} = 0.813 \times 10^{-7}$	$E_{2T} = 0.488 \times 10^{-7}$

Table 2.  $E_{1n}$  and  $E_{2n}$  values for unstable case.

Gen.	Unstable case	
	$E_{1n} (\times 10^{-7})$	$E_{2n} (\times 10^{-7})$
G1	0.293	0.294
G2	1.181	0.994
G3	1.664	1.801
G4	0.128	0.244
G5	0.156	0.217
G6	0.541	0.206
G7	0.020	0.003
G8	0.736	0.833
G9	0.299	0.387
G10	0.874	0.974
	$E_{1T} = 5.892 \times 10^{-7}$	$E_{2T} = 5.953 \times 10^{-7}$

It is noted from Tables 1 and 2 that  $E_{1n}$  and  $E_{2n}$  values for the stable case are much lower than those for the unstable case. Hence,  $E_{1T}$  and  $E_{2T}$  values for the stable case are also much lower than those for the unstable case.

Figure 5 shows the architecture of the RBFNN, obtained after training. The input layer has 8 neurons each having a bias while the output layer has 1 neuron, also with a bias. All biases in the input layer have the same weight value of 0.83255. The bias in the output layer has weight value of 10.1085. Table 3 shows all other weight values. To improve the performance of the RBFNN in both training and testing phases, each input value is multiplied by  $10^7$  to remove the  $10^{-7}$  factor in the  $E_{1T}$  and  $E_{2T}$  values.

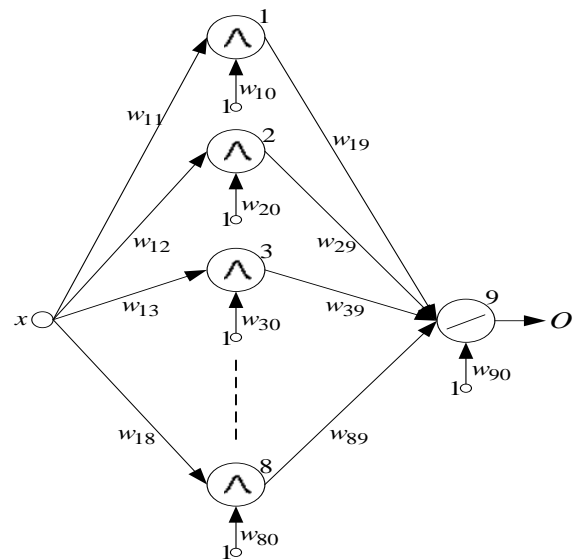

Figure 5. Architecture of trained RBFNN.

Table 3. Weight values of RBFNN.

Input signal – Input layer	Input layer – Output layer
$w_{11} = 6.4$	$w_{19} = -9.1081$
$w_{15} = 0.85$	$w_{59} = -58.9401$
$w_{12} = 64.7$	$w_{29} = -9.1085$
$w_{16} = 0.6898$	$w_{69} = 0$
$w_{13} = 10.2$	$w_{39} = -9.1081$
$w_{17} = 0.6538$	$w_{79} = 78.8915$
$w_{14} = 1.529$	$w_{49} = -1.3852$
$w_{18} = 0.2649$	$w_{89} = -34.2011$

The output of the RBFNN like any other neural network in the testing phase may have an error with respect to its actual value, in a manner similar to what pertains in digital communication networks [3]. In this work, a criterion presented as (9) and (10) is used to derive the final output of the RBFNN.

$$O \geq 0.5 \rightarrow O = 1 \tag{9}$$

$$O < 0.5 \rightarrow O = 0 \tag{10}$$

The RBFNN outputs are computed as follows using (4):

*Stable case*

$$O(E_{1T} = 0.813) = 0.0001$$

$$O(E_{2T} = 0.488) = 0.0062$$

Applying (10), the output set of RBFNN is {0, 0} which indicates transient stability.

*Unstable case*

$$O(E_{1T} = 5.892) = 2.4922$$

$$O(E_{2T} = 5.953) = 2.1783$$

Applying (9), the output set of RBFNN is {1, 1} which indicates transient instability.

## 8. Conclusion

The technique presented uses data captured in a very small time frame (i.e. 4.17 ms for a 60Hz network or 5 ms for a 50Hz network, after a line or bus trip). Such a short data capture window will allow for speedy response in the event of a fault. Generator bus voltages used as input parameter can be captured in real-time, and as a result, permit real-time operation of the presented technique. Wavelet decomposition and radial basis function neural networks are also simple to implement. These factors make the scheme feasible and easy to implement.

## References

- [1] E. A. Frimpong, J. Asumadu and P. Y. Okyere, "Neural Network and Speed Deviation based Generator Out-of-Step Prediction Scheme", *Journal of Electrical Engineering*, vol. 15, no. 2, pp. 1-8, 2015.
- [2] Final Report on the August 14, 2003 Blackout in the United States and Canada: Causes and Recommendations, (April, 2004) Available: <http://www.nerc.com/filez/blackout.html>
- [3] N. Amjady, and S. F. Majedi, "Transient stability prediction by a hybrid intelligent system", *IEEE Transaction on Power Systems*, vol. 22, no. 3, pp. 1275 -1283, 2007.
- [4] H.-Z. Guo, H. Xie, B.-H. Zhang, G.-L. Yu, P. Li, Z.-Q. Bo, and A. Klimek, "Study on Power System Transient Instability Detection Based on Wide Area Measurement System", *European Transactions on Electrical Power*, vol. 20, pp. 184–205, 2010.
- [5] E. A. Frimpong, P. Y. Okyere and J. A. Asumadu, "On-line determination of transient stability status using multilayer perceptron neural network", *Journal of Electrical Engineering*, vol. 69, no. 1, pp. 1-7, 2018.
- [6] A. N. Al-Masri, M. Z. A. A. Kadir, H. Hizam and N. Mariun, "A novel implementation for generator rotor angle stability prediction using an adaptive artificial neural network application for dynamic security assessment", *IEEE Transactions on Power Systems*, vol. 28, no. 3, pp. 2516-2525, 2013.
- [7] D. R. Gurusinghe and A. D. Rajapakse, "Post-Disturbance Transient Stability Status Prediction Using Synchrophasor Measurements", *IEEE Transactions on Power Systems*, vol. 31, no. 5, pp. 3656-3664, 2016.
- [8] A. D., Rajapakse, F. Gomez, O. M. K. K. Nanayakkara, P.A. Crossley and V. V. Terzija, "Rotor angle stability prediction using post-disturbance voltage trajectory patterns", *IEEE Transactions on Power Systems*, vol. 25, no. 2, pp. 945-956. 2010.
- [9] S. Pittner and S. V. Kamarthi, "Feature Extraction from Wavelet Coefficients for Pattern Recognition Tasks", *IEEE Transactions on Pattern Analysis and Machine Intelligence*, vol. 21, no. 1, pp. 83-88, 1990.
- [10] D. Chanda, N. K. Kishore and A. K. Sinha "Application of Wavelet Multiresolution Analysis for Classification of Faults on Transmission lines", in *IEEE Conference on Convergent Technologies for the Asia-Pacific Region*, pp. 1464-1469, 2003.
- [11] M. Uyar, S. Yildirim and M. T. Gencoglu, "An Effective Wavelet-Based Feature Extraction Method for Classification of Power Quality Disturbance Signals", *Electric Power Systems Research*, vol. 78, pp. 1747–1755, 2008
- [12] O. A. Rosso, S. Blanco, J. Yordanova, V. Kolev, A. Figliola, M. Schürmann and E. Başar, "Wavelet entropy: a new tool for analysis of short duration brain electrical signals", *Journal of Neuroscience Methods*, vol. 105, pp. 65-75, 2001.
- [13] Z. He, S. Gao, X. Chen, J. Zhang, Z. Bo and Q. Qian, "Study of a new method for power system transients

- classification based on wavelet entropy and neural network”, *Electrical Power and Energy Systems*, vol. 33, pp. 402-410, 2011.
- [14] A. Karami, “Radial Basis Function Neural Network for Power System Transient Energy Margin Estimation”, *Journal of Electrical Engineering & Technology*, vol. 3, no. 4, pp. 468-475, 2008.
- [15] M. H. Beale, M. T. Hagan and H. B. Demuth, *Neural Network Toolbox™*, *User Guide*, MATLAB, R2016b, 2016.
- [16] D. Hou, “Relay Element Performance During Power, System Frequency Excursions”, in *61st Annual Conference for Protective Relay Engineers College Station*. 2008.
- [17] Y. Song, “Design of Secondary Voltage and Stability Controls with Multiple Control Objectives”, PhD, School of Electrical and Computer Engineering, Georgia Institute of Technology, Georgia, 2009.