

This copy of the thesis has been supplied on condition that anyone who consults it is understood to recognize that its copyright rests with its author and that no quotation from the thesis and no information derived from it may be published without the author's prior consent.



# **Links and Graphs**

by

**Israa Tawfik**

A thesis submitted to the University of Plymouth in partial fulfillment of  
the requirements for the degree of

**DOCTOR OF PHILOSOPHY**

School of Computing and Mathematics

Faculty of Science and Technology

University of Plymouth

July 2013



## Links and Graphs

Israa Tawfik

### Abstract

In this thesis we derive some basic properties of graphs  $G$  embedded in a surface determining a link diagram  $D(G)$ , having a specified number  $\mu(D(G))$  of components. ( The relationship between the graph and the link diagram comes from the tangle which replaces each edge of the graph). Firstly, we prove that  $\mu(D(G)) \leq f(G) + 2g$ , where  $f(G)$  is the number of faces in the embedding of  $G$  and  $g$  is the genus of the surface. Then we focus on the extremal case, where  $\mu(D(G)) = f(G) + 2g$ . We note that  $\mu(D(G))$  does not change when undergoing graph Reidemeister moves or embedded  $\Delta \leftrightarrow Y$  exchanges. It is also useful that  $\mu(D(G))$  changes only very slightly when an edge is added to the graph.

We finish with some observations on other possible values of  $\mu(D(G))$ . We comment on two cases: when  $\mu = 1$ , and the Petersen and Heawood families of graphs. These two families are obtained from  $K_6$  and  $K_7$  respectively by using  $\Delta \leftrightarrow Y$  exchanges.



# Contents

<b>Abstract</b>	<b>v</b>
<b>List of figures</b>	<b>ix</b>
<b>Acknowledgements</b>	<b>xiii</b>
<b>Author's declaration</b>	<b>xv</b>
<b>1 Introduction</b>	<b>1</b>
1.1 Introduction . . . . .	1
1.2 Topological background . . . . .	1
1.3 Links . . . . .	2
1.4 Graphs . . . . .	3
1.5 Previous studies . . . . .	8
1.6 Overview of thesis . . . . .	10
<b>2 Background properties of <math>\mu(D(G))</math></b>	<b>13</b>
2.1 Connected sum . . . . .	13
2.2 Reidemeister 1 moves . . . . .	14
2.3 Reidemeister 2 moves . . . . .	15
2.4 Reidemeister 3 moves . . . . .	18
2.5 Other moves . . . . .	19
<b>3 Extremal plane graphs</b>	<b>21</b>
3.1 Connected plane graphs . . . . .	21

3.2	Extremal plane graphs . . . . .	24
3.3	Two sum and tensor product . . . . .	38
<b>4</b>	<b>Extremal graphs on surfaces of genus <math>g</math></b>	<b>41</b>
4.1	Connected graphs . . . . .	41
4.2	Extremal graph . . . . .	49
4.3	Torus theorems . . . . .	54
<b>5</b>	<b>Graphs with <math>\mu = 1</math></b>	<b>59</b>
5.1	Reidemeister 2 moves . . . . .	59
5.2	Connected sum . . . . .	61
5.3	Reidemeister 3 moves . . . . .	63
5.4	Other moves . . . . .	63
<b>6</b>	<b>Petersen family and Heawood family</b>	<b>65</b>
6.1	Intrinsically linked and intrinsically knotted graphs . . . . .	68
6.1.1	The Petersen family . . . . .	68
6.1.2	The Heawood family . . . . .	74
6.2	The number of components of a link diagram in the Petersen and Heawood families . . . . .	74
6.2.1	Embedded Petersen families . . . . .	74
6.2.2	Embedded Heawood families . . . . .	88
<b>7</b>	<b>Conclusion and further work</b>	<b>95</b>
	<b>Index.</b>	<b>102</b>



# List of Figures

1.1	The three types of Reidemeister move: (A) Reidmeister 1, (B) Reidmeister 2, (C) Reidmeister 3. . . . .	3
1.2	The general tangle . . . . .	4
1.3	The medial graph of an embedded graph, and the link diagram which is got from the medial graph . . . . .	5
1.4	A tangle replacing an edge. The dotted lines marked a, b, c, and d are strands of the link diagram, and the straight line joining the two vertices is the edge of the graph replaced by the tangle T. . . . .	6
1.5	Two different embeddings of one graph in the tours. (A) is a cellularly embedded graph, where (B) is embedded but not cellularly. . . . .	7
1.6	The graphs of Reidemeister moves. . . . .	8
1.7	$Y \leftrightarrow \Delta$ exchanges. . . . .	9
2.1	The dotted curved lines are two strands of a single component of the link diagram because $v$ is a cut vertex of the graph, which separates blocks $B_i$ and $B_{i+1}$ . The straight lines are edges of the graph. . . . .	14
2.2	The contraction of two non-parallel edges incident with a vertex of degree two does not change the number of components of a link diagram. . . . .	16
2.3	The contraction of two parallel edges changes the number of components of a link diagram. . . . .	17
2.4	The deletion of a pair of parallel edges bounding a disc does not change the number of components of a link diagram. . . . .	17

2.5	The graph on the left has a pair of parallel edges which does not bound a disc. In the graph on the right the deletion of these parallel edges has changed the number of components of a link diagram. . . . .	18
2.6	The embedded $\Delta - Y$ exchanges do not change the number of components of a link diagram. . . . .	18
2.7	Adding a new edge to the vertices of different arcs decreases the number of components of a link diagram. . . . .	19
2.8	The number of components of a link diagram does not change, if the endpoints of the arcs $\alpha_1$ and $\alpha_2$ come in the order 1,2,3,4 in the component of a link diagram. . . . .	20
2.9	The number of components of a link diagram is increased, if the endpoints of the arcs $\alpha_1$ and $\alpha_2$ come in the order 1,2,4,3 in the component of a link diagram. . . . .	20
3.1	A component of link diagram of a cycle in the embedded graph. . . . .	23
3.2	Adding a new edge to produce an extremal graph. . . . .	25
3.3	(A) is an extremal graph with $\delta(G) = 2$ . (B) has a new edge which makes $\delta(G) = 3$ and does not increase the number of components of a link diagram	27
3.4	The case of an extremal graph without a bridge. $G_1$ has two distinct vertices each one adjacent to a vertex in $G_2$ to obtain $G$ , where the two vertices in $G_2$ are distinct. . . . .	33
3.5	The case of an extremal graph without a bridge. $G_1$ has two distinct vertices adjacent to $G_2 = K_1$ . . . . .	35
3.6	The case of an extremal graph without a bridge. $G_1$ has a vertex adjacent twice to $G_2 = K_1$ . . . . .	36
3.7	A graph $G$ , constructed from two graphs $G_1$ and $G_2$ joined by two edges. .	37
3.8	The two components $a$ and $b$ of a link diagram, moving from $G_1$ to $G_2$ . .	37
3.9	Example of the tensor product on a bridge $b$ of extremal graph. . . . .	40
4.1	The generators of the first homology group $\mathbb{Z} \oplus \mathbb{Z}$ on the torus. . . . .	41

4.2	(A) is a diagram for a pseudo-tree, and (B) is a diagram for a cellularly embedded graph which is not a pseudo-tree. . . . .	42
4.3	Just these four diagrams of $\lambda$ satisfy Theorem 22. . . . .	44
4.4	$L$ is the new longitude cycle and $M$ is the new meridian cycle of $S_{i+1}$ surface, where $e_L$ is an edge in $L$ , but not in $M$ . $e_M$ is an edge in $M$ not in $L$ . . . . .	45
4.5	$\psi_{i+1} \setminus e_M \setminus e_L$ . . . . .	46
4.6	$e_1$ is an internal edge, where $e_2$ is not a internal edge. . . . .	53
4.7	$\alpha$ and $\beta$ are arcs coming from the same component of a link diagram and passing close to vertex $v$ . . . . .	54
4.8	$\alpha$ and $\beta$ are arcs of the same component of a link diagram passing close to vertex $v$ and crossing at edge $e$ . . . . .	55
4.9	Types of $\lambda$ which are not extremal. . . . .	55
5.1	$\mu(D(G+e)) = 1$ , if the endpoints of the arcs $\alpha_1$ and $\alpha_2$ come in the order 1,2,3,4 in the component of a link digram of $G$ , where $\mu(D(G)) = 1$ . . . . .	63
6.1	The Petersen family . . . . .	65
6.2	The Petersen family scheme. . . . .	66
6.3	The Heawood family as it appeared in (8). Each arrow refers to $\Delta - Y$ exchange. . . . .	67
6.4	The Heawood family scheme. . . . .	68
6.5	$K_{3,3,1}$ . . . . .	69
6.6	The edge crossing itself. . . . .	70
6.7	The adjacent edges are crossing. . . . .	71
6.8	The crossing of non adjacent edges in one cycle. . . . .	71
6.9	The crossing of non adjacent edges in two cycles. . . . .	72
6.10	(A) is a $Y$ in $H'$ , (B) replaces each edge in (A) by a double edge, and (C) removes the vertex $x$ in (B) to get a triangle. . . . .	73
6.11	One embedding of $K_6$ in the torus. . . . .	76
6.12	The embedding of a Petersen subfamily in the torus. . . . .	77

6.13	The embedding of a Petersen subfamily in the torus. . . . .	78
6.14	The embeddings of three members of Petersen subfamily in the torus. . .	79
6.15	An embedding of $K_6$ in the torus. . . . .	79
6.16	The embeddings of a Petersen subfamily in the torus. . . . .	80
6.17	An embedding of $Q_7$ in the torus. . . . .	81
6.18	The embedding of some members of a Petersen subfamily in the torus. . .	81
6.19	The embedding of some members of a Petersen subfamily in the torus. . .	82
6.20	The embedding of some members of a Petersen subfamily in the torus. . .	83
6.21	The embedding of some members of a Petersen subfamily in the torus. . .	84
6.22	An embedding of $K_6$ in the torus. . . . .	85
6.23	Embeddings of some members of Petersen subfamily in the torus. . . . .	86
6.24	An embedding of $Q_7$ in the torus. . . . .	87
6.25	Embeddings of some members of Petersen subfamily in the torus. . . . .	87
6.26	Embeddings of some members of Petersen subfamily in the torus. . . . .	89
6.27	An embedding of Heawood subfamily in the torus. . . . .	91
6.28	An embedding of Heawood subfamily in the torus having the embedding of all members of the Heawood family except the embedding of $N_{11}$ . . . .	93
7.1	An example of a graph having even face but not extremal. . . . .	96
7.2	An example of a graph which is eulerian but not extremal. . . . .	96

## Acknowledgements

Completing a PhD is arduous journey with many challenges to be overcome. However, for me personally it was also a journey of self-discovery that tested both my patience and limits. Patience and dedication are the two vital ingredients in completing any task.

There are a number of people without whom this thesis would not have been possible. First and foremost, I would like to thank my first supervisor **Prof Dr Stephen Huggett** for all the guidance, patience and support he has shown me over the past three years and half. Special thanks are also due to my second supervisor Dr Colin Christopher for his part in making this thesis possible. I would also like to stress the importance of all the support shown to me by my peers and relatives (both here in Plymouth and at my home in Iraq).

Last but not least, I wish to thank my family. I am eternally grateful to my two wonderful children (Khalid and Maryam) for their patience and to my husband who has been my rock throughout. Without my husband's encouragement and kindness I would not have found the courage to pursue a PhD. He inspired and enabled me to do so, thus carrying out the wishes of my late parents.



## Author's declaration

At no time during the registration for the degree of Doctor of Philosophy has the author been registered for any other university award. Relevant scientific seminars and conferences were regularly attended at which some of this work was sometimes presented. One paper was submitted for publication.

**Scientific papers:** *Embedded graphs whose links have the largest possible number of components.*

Stephen Huggett and Israa Tawfik, submitted for publication.

### **Presentations given:**

2013: *Extremal and non-extremal graphs on the torus.*

YRM2013, University of Edinburgh.

2013: *Extremal graphs on the torus.*

Seminar, School of Computing and Mathematics, University of Plymouth.

### **Conferences and Courses attended:**

2013: Geometric and topological graph theory, workshop, University of Bristol.

2012: YRM2012, Conference, University of Bristol

.

2011: The annual meeting of the London Mathematical Society.

2011: The postgraduate meeting, London Mathematical Society.

2011: 23rd British Combinatorial Conference, Exeter University.

2011: Women in Mathematics Day, London Mathematical Society.

**Other**

I have been a membership in London Mathematical Society since 2010.

Signed:.....

Date:.....



# Chapter 1

## Introduction

### 1.1 Introduction

The subject of this thesis is the relationship between the graph theory and knot theory. Graph theory is a part of combinatorics, while knot theory is a part of geometric topology. As usual, we hope that ideas from each of these two disciplines will help the other.

Our study focuses on diagrams of unoriented links in  $\mathbb{R}^3$  and the corresponding graphs embedded on surfaces. We start with a graph embedded on  $\mathbb{R}^2$  and calculate its link diagram, and we study the properties of this link diagram by looking at the embedded graph. The simplest such property of the link diagram is  $\mu$ , the number of components. We want to understand those graphs in which  $\mu$  has the largest possible value.

We also look at the embeddings on other surfaces, and at values of  $\mu$  other than the maximum value.

### 1.2 Topological background

In this section we briefly review some important topological information that we need in this study. A **surface** is a topological space in which every point has a neighbourhood homeomorphic to an open set in  $\mathbb{R}^2$ . A surface is **orientable** if it has two sides. A sphere which has  $g$  *handles* added is called a surface of **genus**  $g$ . We need to work with embedded graphs. An **embedding**  $f$  is a one to one continuous function from a topological space  $X$  to a topological space  $Y$ .  $X$  and  $f(X)$  are then homeomorphic.

### 1.3 Links

In this section we introduce the basic concepts in knot theory which will be used later. A **link** is an embedding of  $\mu$  disjoint copies of  $S^1$  in  $\mathbb{R}^3$ , each circle of the link is a **component**, and the number of components is called  $\mu$ . A **knot** is a link when  $\mu = 1$ . A **link diagram** is the image of a projection of a link from  $\mathbb{R}^3$  to  $\mathbb{R}^2$  in which the only singular points are double points. This means the inverse image of each point in a link diagram either one point or two points in  $S^1$ . If the inverse image of the point in a link diagram is two points in  $S^1$  means the link diagram has a crossing.

The connected sum of two links is an operation to join them and obtain one link. This allow to us to define a connected sum of knots (composition or knot sum) as in (1). Let  $J$  and  $K$  be two projections of knots. The **connected sum** of  $J$  and  $K$  is a knot that is obtained by cutting one arc of both  $J$  and  $K$  then joining the four endpoints to create two new arcs, denoted by  $J\#K$ .

Since each link has many diagrams, we need to find the relationship between any two of these diagrams. This is done by using **Reidemeister moves**. The **first Reidemeister move**, wherein an untwisted strand of any component of link becomes twisted and vice versa, is designated **Reidemeister 1**, as shown in figure 1.1 (A).

The **second Reidemeister move** is designated **Reidemeister 2**, and is shown in figure 1.1 (B).

The final type is called the **third Reidemeister move**. Here, there is a crossing in the projection and a strand which slides from one side of the crossing to the other. This type is designated **Reidemeister 3**, and is illustrated in figure 1.1 (C).

**Theorem 1** *Any two diagrams of a link are related by a finite sequence of Reidemeister moves.*

#### Proof

See (6). □

Let  $C_1$  and  $C_2$  be two individual circles of a link in  $\mathbb{R}^3$ . Then the number of times

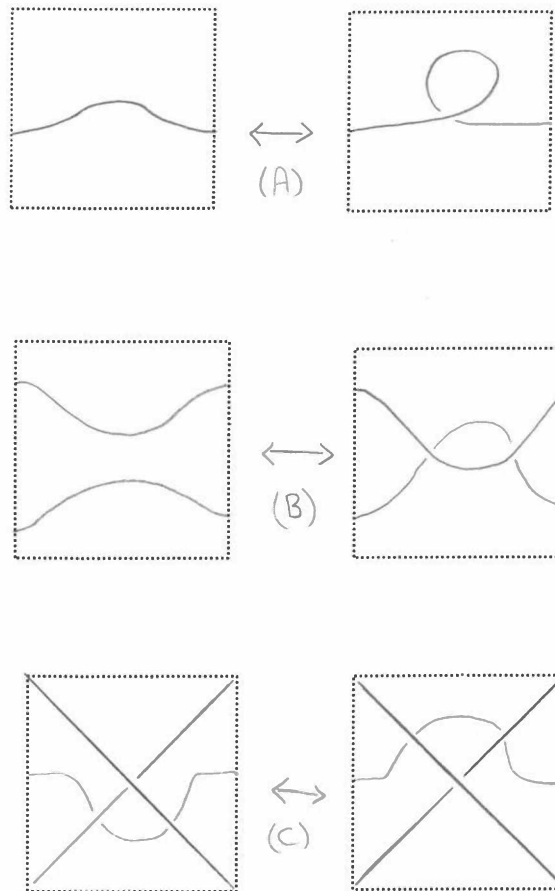

Figure 1.1: The three types of Reidemeister move: (A) Reidemeister 1, (B) Reidemeister 2, (C) Reidemeister 3.

$\text{mod}(2)$  that  $C_1$  crosses over  $C_2$  in the link diagram is called the **mod 2 linking number** of  $C_1$  and  $C_2$ , denoted by  $lk(C_1, C_2)$ .

## 1.4 Graphs

A **graph**  $G$  is a pair of sets. The first, a non empty set of vertices,  $V$ , is denoted by  $V(G)$ , and the second, a non empty set of edges,  $E$ , is denoted by  $E(G)$ . Each edge joins a pair of vertices  $v_i, v_j$ . These vertices are called the **endvertices of edge**  $(v_i, v_j)$ . If  $V(G)$  and  $E(G)$  are finite then  $G$  is called **finite graph**. A graph  $H$  is called a **subgraph** of  $G$  if  $V(H) \subset V(G)$  and  $E(H) \subset E(G)$ . A subgraph  $H$  of  $G$  is called a **spanning** subgraph of

graph  $G$  if  $V(H) = V(G)$ . Suppose that  $e(G)$  is the number of edges in  $G$ , and  $v(G)$  is the number of vertices in  $G$ .

Let  $G$  be a finite graph, then  $G$  is a sub topological space induced in  $\mathbb{R}^3$ . Where we can represent each vertex of a graph as a point in the topological space and each edge of a graph as a closed set. An **embedding** of graph  $G$  is a one to one continuous function from graph  $G$  to a surface. Then  $G$  and  $f(G)$  are homeomorphic. The component of the complement of an embedded graph  $G$  is a **face**, a non empty set of faces of the embedding graph  $G$  denoted  $F(G)$ . Suppose that  $f(G)$  is the number of faces in  $G$ ,

A **plane graph** is a graph embedded on a sphere.

The relationship between the graph and the link diagram is through the tangle which replaces each edge of the graph. A **tangle** in a link projection is defined as a region within the projection plane. This region can be surrounded by a shape (usually a rectangle) which is crossed precisely four times by the link.

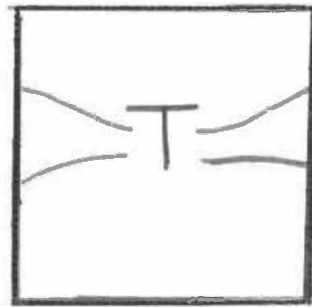

Figure 1.2: The general tangle

A **medial graph**  $M(G)$  of a plane graph  $G$  is a plane graph whose vertices are the edges of  $G$ , any two of the vertices of  $M(G)$  being connected by an edge whenever they are located in the same face of  $G$ , on two adjacent edges of  $G$ .

Using the medial construction, a graph  $G$  embedded on a surface determines a link diagram  $D(G)$ , which has a certain number  $\mu$  of components of a link diagram, as in figure 1.3.

Let us consider the following three cases for the tangle, which appear in figure 1.4:

1. Strand a is joined to c, and b is joined to d. In this case the number of components of the link diagram can vary, but it does not depend on the detail of the tangle. So, we

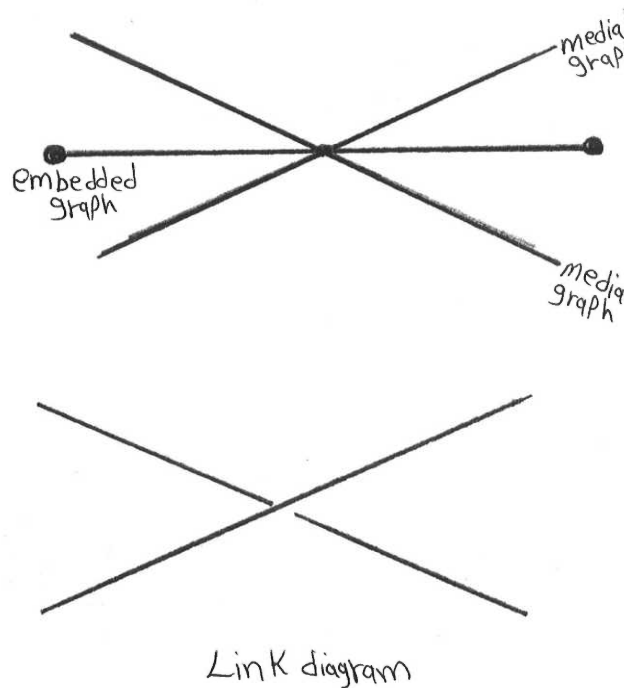

Figure 1.3: The medial graph of an embedded graph, and the link diagram which is got from the medial graph

may as well draw this as though each edge of the graph were replaced by a simple crossing in the link diagram.

2. Strand a is joined to b, and c is joined to d. In this case  $\mu$  is always equal to the number of faces  $f$  of the embedded graph.
3. Strand a is joined to d, and b is joined to c. In this case  $\mu$  is always equal to the number of vertices  $V$  of the embedded graph.

Evidently, the first case is the only one of interest, where  $\mu$  depends on the structure of  $G$ .

We sometimes work with **cellularly embedded graphs**, in which each of the faces of the embedded graph is homeomorphic to a disc. This definition is significant because we investigate  $\mu$  on a connected embedded graph.

### Example

Figure 1.5 is the embeddings of one graph. One is a cellularly embedded and another is embedded but not cellularly.

**Deleting an edge** or **contracting an edge**  $e$  in a graph  $G$  are operations used often in

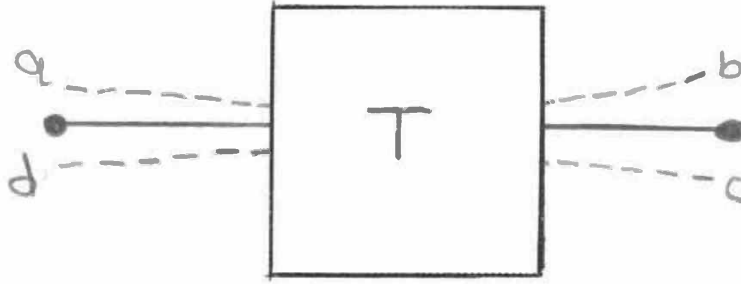

Figure 1.4: A tangle replacing an edge. The dotted lines marked a, b, c, and d are strands of the link diagram, and the straight line joining the two vertices is the edge of the graph replaced by the tangle T.

this thesis. The notation  $G \setminus e$  denotes the graph  $G$  with edge  $e$  deleted. It has the same vertex set as  $G$ , but one less edge. The notation  $G/e$  denotes the graph  $G$  with edge  $e$  contracted. Here the edge  $e$  is deleted and its endvertices identified. It has one less vertex and one less edge than  $G$ .

If  $G$  is a plane graph, the **dual graph**  $G^*$  is defined as having a vertex corresponding to each face of  $G$ , and an edge joining two vertices corresponding to neighbouring faces in  $G$ . We note the following:

1.  $f(G) = v(G^*)$ .
2.  $E(G) \cong E(G^*)$ .
3.  $v(G) = f(G^*)$ .

**Lemma 1** *If  $G$  is a plane graph, then  $D(G) = D(G^*)$ .*

### Proof

Any pair of edges  $e \in E(G)$  and  $e^* \in E(G^*)$  related by the isomorphism in 2 above give rise to the same crossing in the link diagram.  $\square$

If two edges have the same endvertices they are called **parallel edges**. If two edges have one common vertex of degree two they are called **series edges**.

We denote by  $I_k$  the dual graph of the cycle  $C_k$  having  $k$  edges and  $k$  vertices, where  $I_k$  is a graph of two vertices and  $k$  edges which are all parallel.

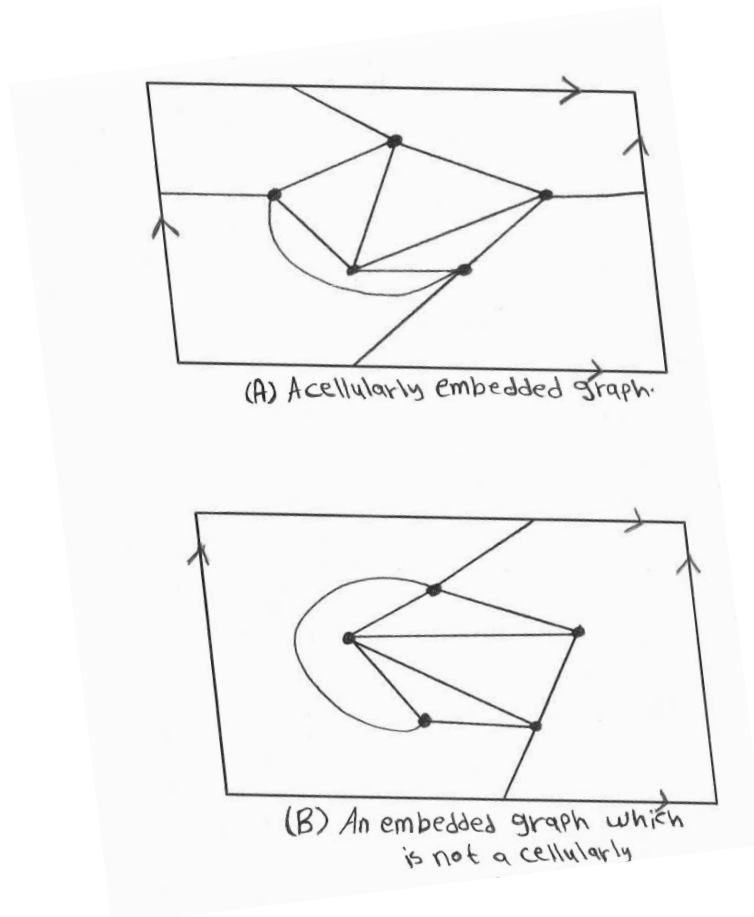

Figure 1.5: Two different embeddings of one graph in the torus. (A) is a cellularly embedded graph, where (B) is embedded but not cellularly.

Some of our results deal with a **bridge**, which is an edge whose deletion increases the number of components of the graph. Moreover, we deal with a **loop** which is an edge whose end vertices are equal. The definition of **blocks** refers to a **cut vertex**, which is a vertex whose deletion increases the number of components of the graph. A nontrivial connected graph which does not have a cut vertex is called a **nonseparable** graph. A subgraph  $H$  of graph  $G$  is called a block if it is a maximal nonseparable subgraph.

The Reidemeister 1 move on a link diagram corresponds to a bridge or a loop, as in figure 1.6 (A). The Reidemeister 2 move on a link diagram corresponds to a pair of parallel edges or series edges, as in the figure 1.6 (B). The Reidemeister 3 move on a link diagram corresponds to a **Y**  $\leftrightarrow$   **$\Delta$**  exchange on the graph, as in the figure 1.6 (C).

This replaces a “Y” (which is a vertex of degree 3) by a triangle, or vice versa, as in figure 1.7.

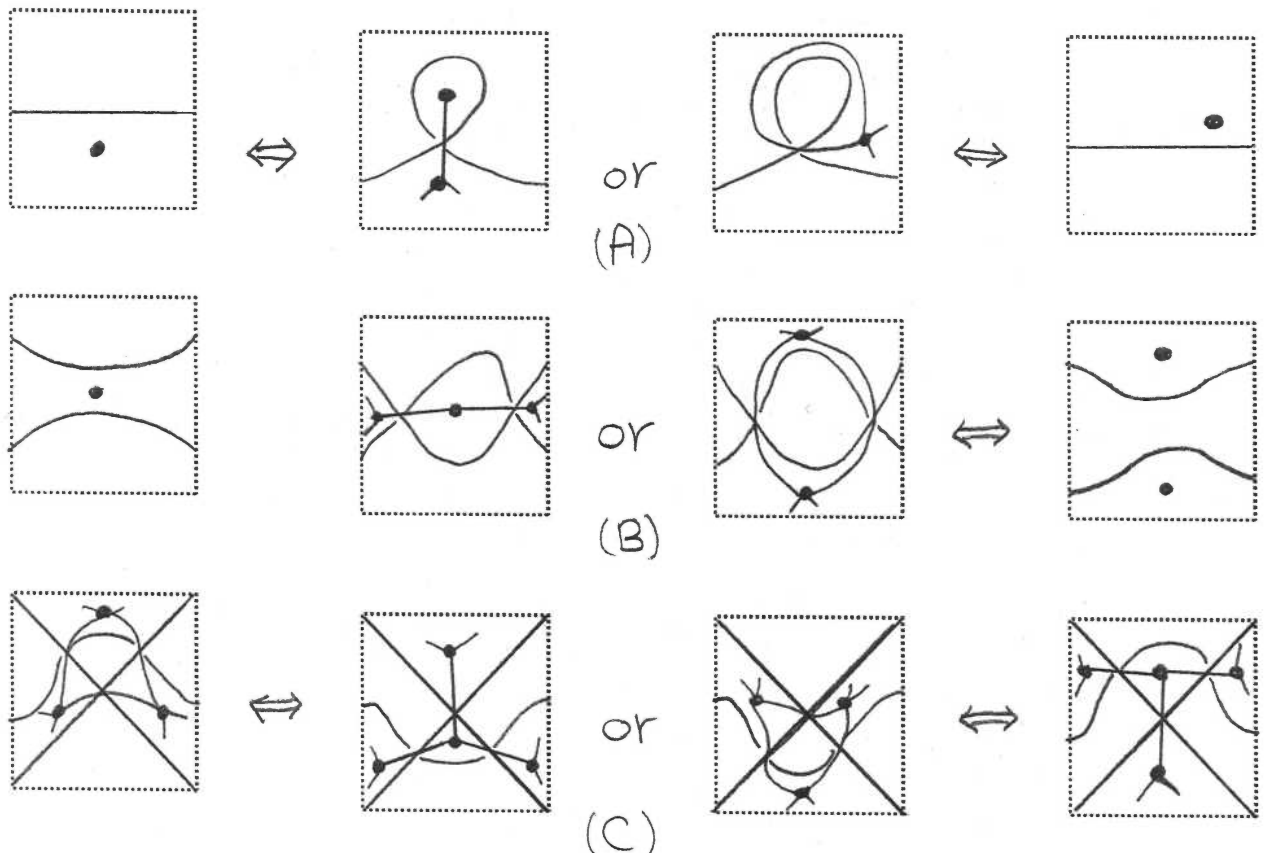

Figure 1.6: The graphs of Reidemeister moves.

For our purposes, we need the graph to be embedded in a surface and the triangle to bound a disc on that surface. Then we refer to the  $Y \leftrightarrow \Delta$  exchanges as **embedded**.

We are also interested in working with graphs embedded in the torus, or indeed any orientable surface of genus  $g$ .

## 1.5 Previous studies

The relationship between a graph and the number of components in the corresponding link diagram has been studied by several people.

In 1978, Martin published an article (18) on this relationship for any connected plane graph. This article studied the Tutte polynomial for a special value of  $x = y = -1$ , where the **Tutte polynomial** is defined as in the following:



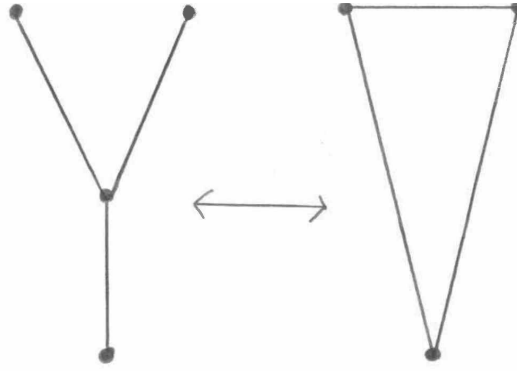

Figure 1.7:  $Y \leftrightarrow \Delta$  exchanges.

$$T(G, x, y) = \begin{cases} xT(G/e, x, y) & \text{if } e \text{ is a bridge;} \\ yT(G \setminus e, x, y) & \text{if } e \text{ is a loop;} \\ T(G/e, x, y) + T(G \setminus e, x, y) & \text{otherwise.} \end{cases}$$

Martin shows the following relationship between the Tutte polynomial and  $\mu$ :

$$T(G; -1, -1) = (-1)^{q(G)} (-2)^{\mu(D(G)) - 1}, \quad (1.1)$$

where  $q(G)$  is the number of edges in  $G$ . In (16), equation (1.1) is generalised to the projective plane and the torus.

Mphako, in (20), actually calculated  $T(G; -1, -1)$ , and hence  $\mu$ , but only for fans, wheels, and 2-sums of graphs which is defined in Chapter 3 Section 3.3. (An  $n$ -**fan** graph is a plane graph consisting of  $K_1$  joined to each vertex of a path of  $n$  vertices. An  $n$ -**wheel** graph is a plane graph consisting of  $K_1$  joined to each vertex of a cycle of  $n$  vertices.)

The number  $\mu$  is the same as the number of “straight-ahead” walks in medial graphs, as described in (23). The focus in (15) is to characterise the plane graphs  $G$  whose  $\mu(D(G))$  is as large as possible, which is the **nullity** plus one; these are the “extremal” graphs. The nullity, denoted  $n(G)$ , is defined by

$$n(G) = |E(G)| - |V(G)| + k(G),$$

where  $k(G)$  is the number of components (maximal connected subgraphs) of  $G$ .

Maximising  $\mu$  is also our principal interest here, although we will study graphs embedded on various orientable surfaces.

The background material can be found in (3), (4), (6), (9), (13) and (1).

## 1.6 Overview of thesis

In chapter 2 we give some background properties of  $\mu$  for graphs embedded on any orientable surface. Section 2.1 shows how  $\mu$  depends on the blocks of the graph  $G$ , which corresponds to undoing a connected sum operation on  $D(G)$ . We note that  $\mu$  does not change when the graph undergoes a graph Reidemeister move or an embedded  $Y \leftrightarrow \Delta$  exchange. The resulting relations are given in sections 2.2, 2.3 and 2.4. In section 2.5, we show that  $\mu$  changes only slightly when an edge is added to the graph.

Chapter 3 introduces some results of extremal graphs in three sections. In section 3.1, we identify the upper bound of the number of components of the link diagrams of cellularly embedded plane graphs. Some of our results replicate those in (15), but our emphasis is different because we are preparing to work on other surfaces.

Section 3.2 introduces the definition of extremal plane graph by using the number of faces of the embedded graph instead of the nullity (as in (15)). We find various properties of extremal graphs. In section 3.3 we describe ways of constructing new extremal graphs using the operations of 2-sum and tensor product.

Chapter 4 extends the idea of an extremal graph to surfaces of genus  $g$ . We restrict our results to cellularly embedded graphs. In section 4.1 we define a **pseudo-tree**, which is a spanning subgraph, comprising a single face, of a graph cellularly embedded in a surface of genus  $g$ . In Chapter 2 Corollary 1 we prove that each plane tree has  $\mu = 1$ , while in this section we prove that the number of components of the link diagram of a pseudo-tree embedded in the torus is less than or equal to three. This allows us to prove further that the number of components of the link diagram of a pseudo-tree embedded in the surface of genus  $g$  is less than or equal to the double the genus plus one. Then we find the upper bound of  $\mu$  for cellularly embedded graphs in surfaces of genus  $g$ .

In section 4.2 we define extremal graphs embedded in surfaces of genus  $g$ . This leads

us to the discovery of some new properties for this type of graph. Not all pseudo-trees are extremal, but each extremal graph has a spanning pseudo-tree which is extremal, which is a useful property. For example, we show that the degree of any vertex in an extremal graph is equal to the number of components of the link diagram passing close to that vertex. The final section in this chapter considers special properties and conjectures in the case of a cellularly embedded graph in the torus.

In chapter 5 we investigate graphs having  $\mu = 1$ .

Chapter 6 focuses on two interesting families of graphs, the **Petersen family** and the **Heawood family**. All the graphs in these two families are cellularly embedded in the torus, but these embeddings are not unique. Our first section centres on previous studies of these families. Almost all are focused on another relationship between knots and graphs. This concerns the intrinsically linked and intrinsically knotted graphs. A graph  $G$  is called **intrinsically linked** (IL) if in any embedding of  $G$  in  $\mathbb{R}^3$  there is a pair of disjoint cycles  $(C_1, C_2)$  with  $lk(C_1, C_2) \neq 0$ . A graph  $G$  is called **intrinsically knotted** (IK) if any embedding of graph  $G$  in  $\mathbb{R}^3$  contains a nontrivial knot. In this section we derive some new results using abstract  $\Delta \leftrightarrow Y$  exchanges.

Section 6.2 has two subsections studying the embedding process of the Petersen and Heawood families. Embedded  $\Delta \leftrightarrow Y$  exchanges restrict the abstract  $\Delta \leftrightarrow Y$  exchanges to an embedded triangle bounding a disc. We find different subfamilies of embedded Petersen and Heawood families by restricting to embedded  $\Delta \leftrightarrow Y$  exchanges, and choosing specific embeddings of  $K_6$  and  $K_7$ . We use the fact that  $\Delta \leftrightarrow Y$  exchanges do not alter the value of  $\mu$ , which is proved in chapter 2, to deduce that those sub-families have fixed  $\mu$  values.



## Chapter 2

# Background properties of $\mu(D(G))$

In this chapter we derive some of the underlying properties of the number of components of the link diagram of a graph. These theorems apply to graphs embedded on any surface. We will find them useful in subsequent chapters. The results of this chapter investigate the properties of a purely local of the embedded graph. These results deal with an embedded graph in any surface, and work with a cellularly or not cellularly embedded graph.

### 2.1 Connected sum

Splitting a connected embedded graph at a cut vertex corresponds to undoing a connected sum operation on the link diagram. The next theorem uses this fact to calculate the number of components of the link diagram of a graph containing  $k$  blocks. The specific case of the following theorem was proved in (15) for a plane graph. Here, the result is generalised to apply to any surface.

**Theorem 2** *Let  $G$  be a connected embedded graph with blocks  $B_1, B_2, \dots, B_k$ . Then*

$$\mu(D(G)) = \sum_{i=1}^k \mu(D(B_i)) - (k - 1).$$

#### **Proof**

For any two adjacent blocks  $B_i$  and  $B_{i+1}$  of  $G$  with common vertex  $v$ , splitting  $G$  at  $v$  into two graphs increases the number of components of a link diagram by one, as in figure

2.1. So splitting  $G$  into  $k$  blocks increases the number of components of a link diagram by  $k - 1$ , and hence the result. (This is a purely local operation, and it therefore applies on any surface.)  $\square$

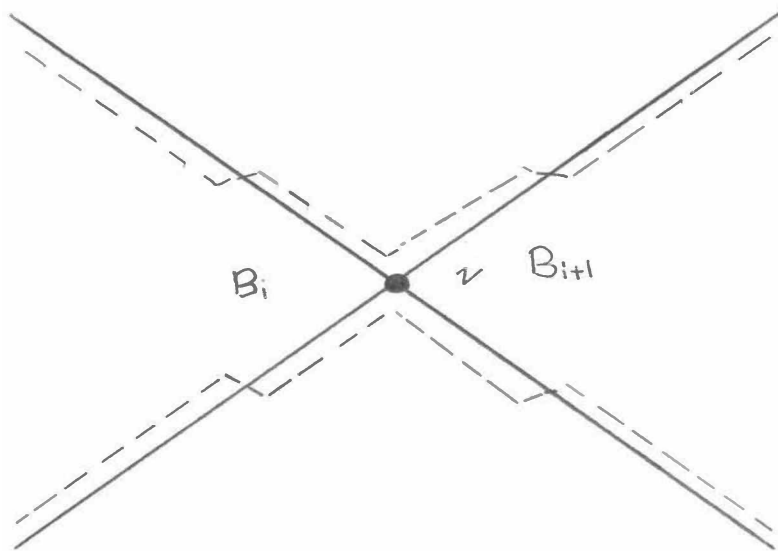

Figure 2.1: The dotted curved lines are two strands of a single component of the link diagram because  $v$  is a cut vertex of the graph, which separates blocks  $B_i$  and  $B_{i+1}$ . The straight lines are edges of the graph.

## 2.2 Reidemeister 1 moves

The number of the components of the link diagram of an embedded graph is invariant under Reidemeister 1 moves. This involves the graph having a bridge.

The following theorem is from (15), but it was proved for the plane graph.

**Theorem 3** *Let  $G$  be a connected embedded graph with a bridge  $e$ . Then*

$$\mu(D(G)) = \mu(D(G/e)).$$

### Proof

Let  $G_1$  and  $G_2$  be the two components of graph  $G \setminus e$ , and let  $B$  be the block in  $G$

containing  $e$ . Then by Theorem 2

$$\begin{aligned}\mu(D(G)) &= \mu(D(G_1)) + \mu(D(G_2)) + \mu(D(B)) - 2 \\ &= \mu(D(G_1)) + \mu(D(G_2)) - 1,\end{aligned}$$

because  $\mu(D(B)) = 1$ . However,  $G/e$  consists of blocks  $G_1$  and  $G_2$ , so by Theorem 2 again

$$\mu(D(G/e)) = \mu(D(G_1)) + \mu(D(G_2)) - 1,$$

and hence the result. □

The following corollary appears in (15) as a lemma. Here it is an elementary corollary; we generalise it in chapter four to cases of surfaces with any number of genus.

**Corollary 1** *Let  $T$  be a tree embedded in the plane, then  $\mu(D(T)) = 1$ .*

**Proof**

We contract all the edges in  $T$  until we obtain the graph  $U$  having just one edge. By Theorem 3,

$$\mu(D(T)) = \mu(D(U)) = 1.$$

□

## 2.3 Reidemeister 2 moves

$\mu(D(G))$  is not affected by the Reidemeister 2 moves. What do these moves correspond to in the graph? We are interested in graphs containing a pair of parallel edges bounding a disc or graphs which contain a pair of edges (not parallel) having a common vertex of degree two.

The following two theorems are proved in (15), but for the embedding of the graph in the plane. Here they are proved for a graph embedded on any orientable surface, as we mentioned earlier in this chapter.

**Theorem 4** *Let  $G$  be an embedded graph. If  $a_1$  and  $a_2$  are edges incident with a common vertex of degree 2, but not parallel, then*

$$\mu(D(G)) = \mu(D(G/a_1/a_2)).$$

**Proof**

This result follows from Reidemeister 2 moves, as in figure 2.2. □

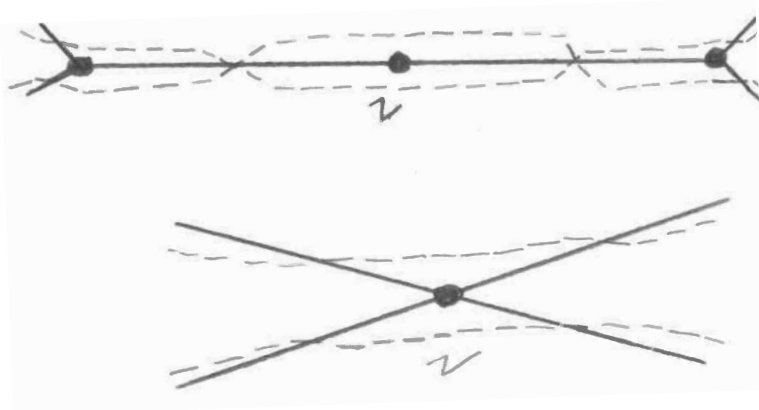

*Figure 2.2:* The contraction of two non-parallel edges incident with a vertex of degree two does not change the number of components of a link diagram.

The following example shows a pair of edges having a vertex of degree two parallel. When they are contracted, then the number of components of a link diagram decreases.

**Example:**

See figure 2.3

In a plane graph parallel edges always bound a disc, but for graphs embedded on other surfaces this is not always going to happen. To generalise this case as in the following theorem, we need to focus on the case of two parallel edges which do bound a disc.

**Theorem 5** *Let  $G$  be an embedded graph. If  $b_1$  and  $b_2$  are two parallel edges bounding a disc in  $S$ , then*

$$\mu(D(G)) = \mu(D(G \setminus b_1 \setminus b_2)).$$

**Proof**



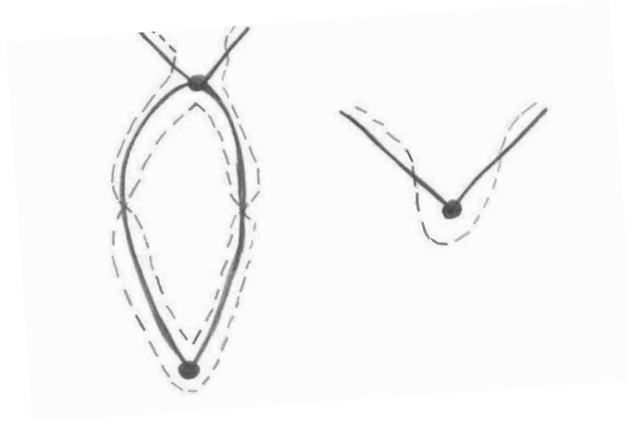

Figure 2.3: The contraction of two parallel edges changes the number of components of a link diagram.

This result follows from Reidemeister 2 moves too, as in figure 2.4. □



Figure 2.4: The deletion of a pair of parallel edges bounding a disc does not change the number of components of a link diagram.

The following example shows that when a pair of parallel edges not bounding a disc is deleted, the number of components of a link diagram changes.

**Example:**

Let  $G$  be a graph embedded in the torus, where  $G = K_5 + e_1$ , and  $e_1$  with its parallel edge  $e_2$  does not bound a disc. Then  $\mu(D(G)) = 1$ , but  $\mu(D(G \setminus e_1 \setminus e_2)) = 3$ , as in figure 2.5.

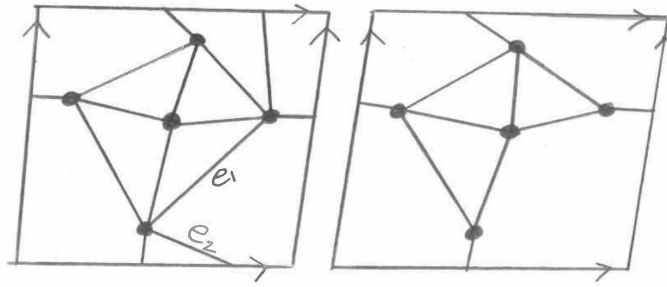

Figure 2.5: The graph on the left has a pair of parallel edges which does not bound a disc. In the graph on the right the deletion of these parallel edges has changed the number of components of a link diagram.

## 2.4 Reidemeister 3 moves

There is another move which keeps the number of components of a link diagram unchanged, the Reidemeister 3 moves. This move is discussed in the following theorem.

**Theorem 6** *Let  $G$  be an embedded graph. Graph  $H$  is derived from  $G$  using embedded  $\Delta - Y$  exchanges. Then both graphs have the same number of components of a link diagram.*

### Proof

The result follows from the Reidemeister 3 moves, as in figure 2.6. □

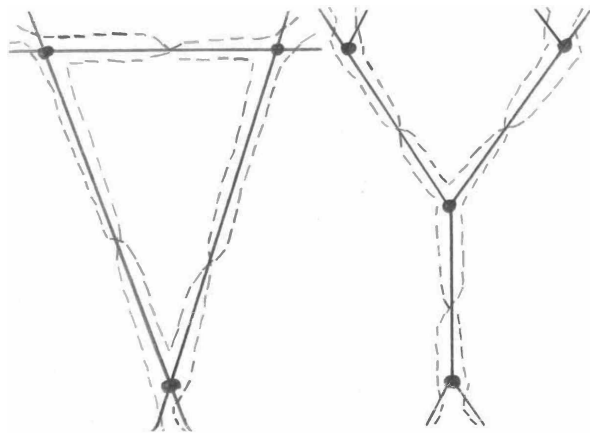

Figure 2.6: The embedded  $\Delta - Y$  exchanges do not change the number of components of a link diagram.

## 2.5 Other moves

In this section the operations on the graph do not always keep the number of components of a link diagram unchanged. They will nevertheless be useful to us in later chapters.

The idea of the next proof comes from (15).

**Theorem 7** *Let  $e$  be a new edge connecting two vertices in the same face of a connected embedded graph  $G$ . Then*

$$\mu(D(G)) - 1 \leq \mu(D(G+e)) \leq \mu(D(G)) + 1.$$

### Proof

If  $e$  is a loop and it bounds a disc then

$$\mu(D(G)) = \mu(D(G+e)),$$

so the result holds.

If  $e$  is a loop which does not bound a disc, or  $e$  is not a loop then there are two cases:

**1** If the arcs  $\alpha_1$  and  $\alpha_2$  are contained in different components of  $D(G)$ , then

$$\mu(D(G+e)) = \mu(D(G)) - 1,$$

as in figure 2.7.

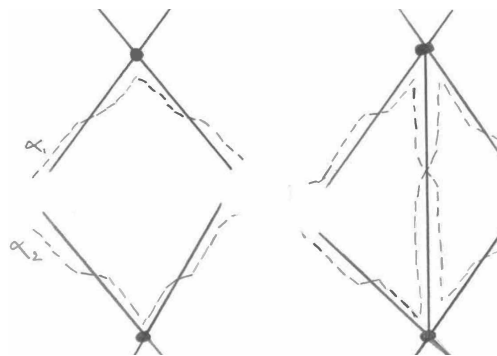

Figure 2.7: Adding a new edge to the vertices of different arcs decreases the number of components of a link diagram.

2 If the arcs  $\alpha_1$  and  $\alpha_2$  are contained in the same component of  $D(G)$ , then there are two further cases.

a Along this component of a link diagram, if the order of the four endpoints of the two arcs  $\alpha_1$  and  $\alpha_2$  is 1, 2, 3, 4 then  $\mu(D(G+e)) = \mu(D(G))$ , as in figure 2.8.

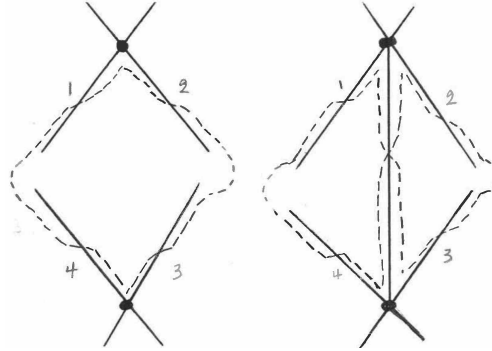

Figure 2.8: The number of components of a link diagram does not change, if the endpoints of the arcs  $\alpha_1$  and  $\alpha_2$  come in the order 1,2,3,4 in the component of a link diagram.

b If the order of the four endpoints of the two arcs  $\alpha_1$  and  $\alpha_2$  is 1, 2, 4, 3 then

$$\mu(D(G+e)) = \mu(D(G)) + 1.$$

□

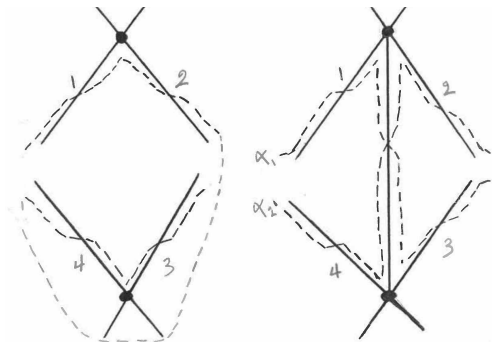

Figure 2.9: The number of components of a link diagram is increased, if the endpoints of the arcs  $\alpha_1$  and  $\alpha_2$  come in the order 1,2,4,3 in the component of a link diagram.

# Chapter 3

## Extremal plane graphs

In this chapter the upper bound of the number of components of the link diagrams of cellularly embedded plane graphs is identified. This number depends on the number of faces in the graph. We also introduce the definition of extremal plane graph, as in (15). In (15) the authors do not use the number of faces. They use instead the nullity.

Some of our results can be found in (15), and we will refer to them as appropriate.

### 3.1 Connected plane graphs

Theorem 8 is the main theorem in this section. It relates the number of components of the link diagram to the number of faces in the graph.

**Theorem 8** *Let  $G$  be a connected plane graph. Then*

$$1 \leq \mu(D(G)) \leq f(G).$$

#### **Proof**

Let  $T$  be a spanning tree of the graph  $G$ . Then  $f(T) = 1$ , and by Corollary 1 we have  $\mu(D(T)) = 1$ , which means the theorem is true for  $T$ .

Now add, one by one, edges to  $T$  in order to obtain  $G$ .

We obtain a sequence of graphs

$$T = G_0, G_1, \dots, G_{s-1}, G_s = G.$$

The insertion of an edge increases the number of faces by exactly one, so for  $i = 0, \dots, s - 1$  we have

$$f(G_{i+1}) = f(G_i) + 1 = f(G_0) + i + 1.$$

By Theorem 7

$$\mu(D(G_{i+1})) \leq \mu(D(G_i)) + 1 \quad (3.1)$$

$$\leq \mu(D(G_0)) + i + 1. \quad (3.2)$$

Since  $\mu(D(G_0)) = f(G_0)$ , we must have  $\mu(D(G_{i+1})) \leq f(G_{i+1})$  for each  $i$ , which means that  $\mu(D(G)) \leq f(G)$ .  $\square$

If  $G^*$  is the plane dual of the graph  $G$ , then  $v(G) = f(G^*)$ . Also, by Lemma 1  $D(G^*) = D(G)$ .

**Corollary 2** *Let  $G^*$  be a connected plane graph. Then  $\mu(D(G)) \leq v(G)$ .*

**Proof**

From Theorem 8

$$\mu(D(G^*)) \leq f(G^*) = v(G).$$

Since  $D(G)$  and  $D(G^*)$  are same by Lemma 1, then  $\mu(D(G)) = \mu(D(G^*))$  and the result follows immediately.  $\square$

The following theorem is important in finding some special significant cases. These will be introduced throughout this chapter in the next section, when we will define the status of  $\mu(D(G)) = f(G)$ . This status is impossible in the condition of a connected graph containing a pair of parallel edges, if the deletion of this pair keeps the graph connected.

**Theorem 9** *Let  $G$  be a connected plane graph with a pair of parallel edges  $a$  and  $b$ . If  $G \setminus a \setminus b$  is connected, then*

$$\mu(D(G)) \leq f(G) - 2.$$

**Proof**

Since  $a$  and  $b$  are parallel edges, by Theorem 5

$$\mu(D(G)) = \mu(D(G \setminus a \setminus b)).$$

But  $G \setminus a \setminus b$  is connected, so

$$f(G) = f(G \setminus a \setminus b) + 2.$$

Therefore

$$\mu(D(G)) = \mu(D(G \setminus a \setminus b)) \leq f(G \setminus a \setminus b) = f(G) - 2$$

□

The following two lemmas are helped in proof of Theorem 10.

**Lemma 2** *Each component of the link diagram of a graph traces an even cycle in the graph.*

**Proof**

Suppose that  $\gamma$  is one component of the link diagram of the graph  $G$ .  $\gamma$  determines a cycle  $C$  in  $G$ . We need to prove that  $C$  is an even cycle.

Since  $\gamma$  crosses the edges of  $C$  from left to right and vice versa, we can label the vertices of cycle  $C$  by  $R$  and  $L$ , as in figure 3.1. No two consecutive vertices have the same

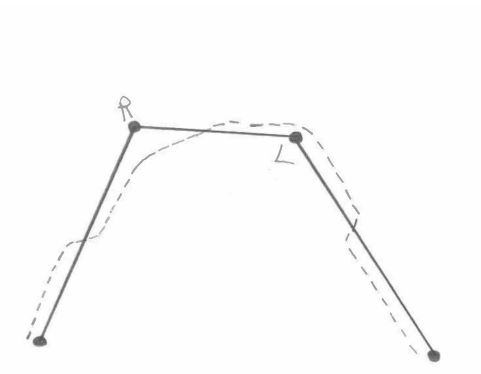

Figure 3.1: A component of link diagram of a cycle in the embedded graph.

label, and so the cycle  $C$  must be even.  $\square$

**Lemma 3** *Each component of the link diagram of a graph has an even number of odd faces.*

**Proof**

Suppose  $C$  is an even cycle in the embedded graph  $G$ . We can choose one side of this cycle which has an even number of odd faces. If a new edge is added to one face of  $C$  then the number of odd faces is increased either zero or two. If the new edge is added to an even face then the number of odd faces either increased two or does not increase. If the new edge is added to an odd face then the number of odd faces does not increase.  $\square$

## 3.2 Extremal plane graphs

If  $G$  is a connected plane graph then  $G$  is called **extremal** if

$$\mu(D(G)) = f(G).$$

A face of a plane graph is called **even** if it has an even number of edges.

Theorem 10 was proved in (15), but using a different method.

**Theorem 10** *If  $G$  is extremal then each face of  $G$  is even.*

**Proof**

Let  $T$  be a spanning tree of  $G$ , and let

$$T = G_0, G_1, G_2, \dots, G_s = G,$$

be a sequence of graphs as in the proof of Theorem 8. Since  $T$  and  $G$  are extremal then each  $G_i$  in the sequence is extremal. Otherwise  $\mu(D(G_i)) < f(G_i)$ , and then from Theorem 7 we would have  $\mu(D(G_{i+1})) < f(G_{i+1})$  and eventually  $\mu(D(G)) < f(G)$ .



$T$  has one even face because each edge in  $T$  counts two times. Suppose that there is a graph in this sequence with an odd face, and let  $G_{i+1}$  be the first such graph.  $G_{i+1} = G_i + e$ , where  $e$  has been inserted into a necessarily even face in  $G_i$ , creating two odd faces  $f_1$  and  $f_2$  in  $G_{i+1}$ .

Because all the graphs in the sequence are extremal, we must be in case 2b of Theorem 7.

Choose a component of  $D(G_{i+1})$  containing face  $f_1$  and including arc 13, as in figure 3.2. This component of a link diagram defines an even cycle in the edges of  $G_{i+1}$ . But the faces inside this cycle are all even except  $f_1$ , because all except  $f_1$  come from  $G_i$ , which is a contradiction by Lemma 2 and Lemma 3.  $\square$

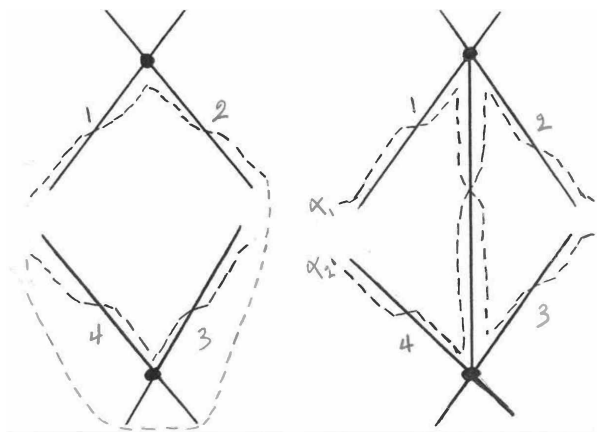

Figure 3.2: Adding a new edge to produce an extremal graph.

By the definition of the dual graph and the previous theorem we can deduce that the following corollary. This corollary has used the relationship between eulerian cycles and even faces of the graph, where (9) has proved “ a connected graph  $G$  is eulerian if and only if every vertex of  $G$  is even.

**Corollary 3** *If  $G$  is extremal then  $G^*$  is eulerian.*

**Proof**

From Theorem 10 each vertex in  $G^*$  has even degree, so  $G^*$  is eulerian.  $\square$

The converse of this corollary is not true. For example, let  $G$  be the dual graph of

$K_{2,2}$ . Then  $G^*$  is  $I_4$  and it is eulerian but  $G$  is not extremal because  $\mu(D(G)) = 2$  when  $f(G) = 4$ .

The relationship between eulerian cycles and bipartite graphs has been given in (14), where each plane graph is eulerian if and only if its dual bipartite, and given us the following corollary.

**Corollary 4** *If  $G$  is extremal then  $G$  is bipartite.*

**Proof**

This follows from Corollary 3 and the well known result that the dual of an eulerian graph is bipartite (14). □

Define  $\delta(G)$  to be the **minimum degree** of  $G$ .

The following theorem was proved in (15) by showing that the embedding of any plane graph is not extremal if  $\delta(G) \geq 3$ .

**Theorem 11** *If  $G$  is extremal, then  $\delta(G) < 3$ .*

**Proof**

Let

$$T = G_0, \dots, G_{i-1}, G_i, \dots, G_s = G$$

be a sequence of extremal graphs, where each of

$$G_0, \dots, G_{i-1}$$

has  $\delta(G) < 3$  and each of

$$G_i, \dots, G_s$$

has  $\delta(G) \geq 3$ . In this case  $G_{i-1}$  has  $\delta = 2$ . When we add an edge to  $G_{i-1}$  to get  $G_i$  we get a contradiction with Theorem 8, because the number of faces increases in  $G_i$  but the number of components does not, as in figure 3.3. □

We can use Theorem 11 to determine whether or not a plane graph is extremal. The following theorem uses a **simple plane graph** which means a connected plane graph having no loops and parallel edges.

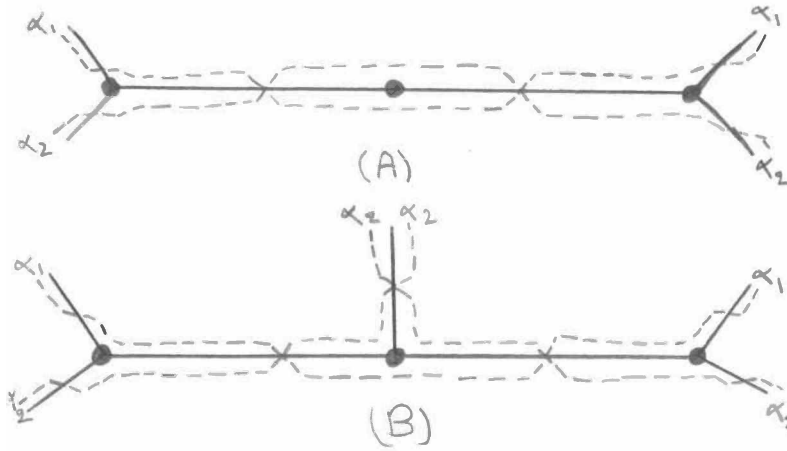

Figure 3.3: (A) is an extremal graph with  $\delta(G) = 2$ . (B) has a new edge which makes  $\delta(G) = 3$  and does not increase the number of components of a link diagram

**Theorem 12** *Let  $G$  be a connected plane graph with at least one edge, then  $G$  is simple if and only if  $G^*$  is not extremal.*

**Proof**

Suppose  $G$  is a simple connected plane graph with at least one edge.  $G^*$  cannot have a vertex of degree 0, because  $G$  has at least one edge. It cannot have a vertex of degree 1, because  $G$  does not have a loop. Finally, it cannot have a vertex of degree 2, because  $G$  does not have parallel edges.

So by Theorem 11,  $G^*$  is not extremal. The same method yield the converse.  $\square$

The idea of the previous theorems can be developed in two ways. First, we can provide a specific case of the relationship between the number of components of the link diagram and the number of vertices of any connected plane graph. We use the facts that  $f(G) = v(G^*)$  and  $\mu(D(G)) = \mu(D(G^*))$ .

**Theorem 13** *Let  $G$  be a connected plane graph with at least one edge. Then  $\mu(D(G)) < v(G)$  if and only if  $G^*$  is not extremal.*

**Proof**

If  $G^*$  is not extremal then by Theorem 8

$$\mu(D(G^*)) < f(G^*),$$

which means that

$$\mu(D(G)) < v(G).$$

□

Secondly, the idea of Theorem 12 is further developed in order to obtain another bound for  $\mu$ .

**Theorem 14** *If  $G$  is an extremal simple plane graph with at least two edges then*

$$\mu(D(G)) \leq v(G) - 2.$$

**Proof**

Since  $G$  is extremal then by Theorem 10 each face in  $G$  is even.

Let  $F_i$  be the number of faces with  $i$  edges. Simple counting arguments give

$$f(G) = F_4 + F_6 + \dots$$

$$2e(G) = 4F_4 + 6F_6 + \dots$$

and

$$4f(G) = 4F_4 + 4F_6 + \dots$$

Therefore

$$4f(G) \leq 2e(G),$$

which means that

$$f(G) \leq e(G)/2, \tag{3.3}$$

By using the Euler equation for the plane graph

$$f - e + v = 2,$$

we have

$$f(G) = 2 + e(G) - v(G). \quad (3.4)$$

By 3.3 and 3.4

$$\begin{aligned} e(G) - v(G) + 2 &\leq e(G)/2, \\ e(G)(1 - (1/2)) &\leq v(G) - 2, \\ (1/2)e(G) &\leq v(G) - 2, \\ f(G) &\leq v(G) - 2. \end{aligned}$$

Since  $G$  is extremal then

$$\mu(D(G)) \leq v(G) - 2.$$

□

We can get the following corollary for a graph with the same properties as Theorem 14 to prove the dual of it is not extremal.

**Corollary 5** *Let  $G$  be an extremal simple plane graph with at least two edges, then  $G^*$  is not extremal.*

**Proof**

Since  $G$  is extremal then by Theorem 14

$$\mu(D(G)) \leq v(G) - 2,$$

which means that

$$\mu(D(G^*)) \leq f(G^*) - 2.$$

Hence the result. □

Theorem 15 has an interesting relationship between the extremal graph and the structure of the dual graph (as proved in (15)).

**Theorem 15** *Let  $G$  be a simple connected plane graph with a non-trivial dual. Then  $G$  is extremal if and only if there is an even non-negative number of edges between each pair of vertices of  $G^*$ .*

**Proof**

Let  $G$  be extremal and suppose that  $G^*$  has an odd number of edges between a pair of vertices. When we delete each pair of parallel edges and loops in  $G^*$ , we get  $H$ , a simple plane graph with at least one edge. By Theorem 5

$$\mu(D(G^*)) = \mu(D(H)),$$

by Theorem 12  $H^*$  is not extremal and by Theorem 13

$$\mu(D(H)) < v(H) = v(G^*),$$

this gives

$$\mu(D(G^*)) < v(G^*).$$

By Corollary 2  $G$  is not extremal and this is a contradiction.

Now, if  $G^*$  has an even non-negative number of edges between each pair of vertices, then we delete all pairs of parallel edges in it, to obtain a graph with an empty set of edges. By Theorem 5 this does not change the number of components, and so

$$\mu(D(G)) = \mu(D(G^*)) = v(G^*) = f(G).$$

Therefore  $G$  is extremal. □

Furthermore, Theorem 16 gives important and useful relationships between extremal

graphs.

**Theorem 16** *Let  $G$  be a connected plane graph. Then the following statements are true.*

- a** *Let  $e$  be a bridge of  $G$ . Then  $G/e$  is extremal if and only if  $G$  is extremal.*
- b** *Let  $v$  be a vertex of degree 2 with exactly one adjacent vertex. Then  $G \setminus v$  is extremal if and only if  $G$  is extremal.*
- c** *Let  $v$  be a vertex of degree 2 with two different adjacent vertices  $x$  and  $y$ . Then  $G/(v,x)/(v,y)$  is extremal if and only if  $G$  is extremal.*
- d**  *$G$  is extremal if and only if each block of  $G$  is extremal.*
- e** *Let  $G$  be extremal, and  $e$  not a bridge in  $G$ . Then  $G \setminus e$  is extremal.*

**Proof**

- a** Let  $G$  be extremal. By Theorem 3

$$\mu(D(G/e)) = \mu(D(G)) = f(G) = f(G/e).$$

Therefore  $G/e$  is extremal. The same method gives the converse.

- b** Let  $G$  be extremal.  $G \setminus v$  is a connected plane graph, and by Theorem 5

$$\mu(D(G)) = \mu(D(G \setminus v)) + 1.$$

Also,

$$f(G) = f(G \setminus v) + 1.$$

So  $G \setminus v$  is extremal. The same method yields the converse.

- c** Let  $G$  be extremal.  $G/(v,x)/(v,y)$  is a connected plane graph, and by Theorem 4

$$\mu(D(G)) = \mu(D(G/(v,x)/(v,y))).$$

Also,

$$f(G) = f(G/(v,x)/(v,y)).$$

So  $G/(v,x)/(v,y)$  is extremal. The same method gives the converse.

**d** Let  $B_1, B_2, \dots, B_k$  be the blocks of  $G$ , and suppose that  $G$  is extremal. Then from Theorem 2 we have

$$\sum_{i=1}^k \mu(D(B_i)) - k + 1 = \mu(D(G)) \quad (3.5)$$

$$= \sum_{i=1}^k f(B_i) - k + 1. \quad (3.6)$$

Therefore

$$\sum_{i=1}^k \mu(D(B_i)) = \sum_{i=1}^k f(B_i),$$

because  $\mu(D(B_i)) \leq f(B_i)$ , so each  $B_i$  is extremal. The converse is proved similarly.

**e** Since  $e$  is not a bridge,  $G \setminus e$  is a connected plane graph and

$$f(G) = f(G \setminus e) + 1.$$

By Theorem 7

$$\mu(D(G)) \leq \mu(D(G \setminus e)) + 1,$$

but

$$\mu(D(G)) = f(G) = f(G \setminus e) + 1,$$

and so

$$\mu(D(G \setminus e)) \geq f(G \setminus e).$$

Hence by Theorem 8  $G \setminus e$  is extremal.  $\square$

In the next theorem we show that all plane extremal graphs can be obtained from  $K_1$  through the use of some processes on the graph. Note that this theorem was proved in (15)



by using the same idea of the following proof; in this proof we need the graph  $G_i/(x_i, y_i)$  which means graph  $G_i$  obtained from  $G$  by identifying the vertices  $x_i$  and  $y_i$ . First we need to give the following example which contains some details of equations 3.7 and 3.8.

### Example

Let  $G$  be an extremal graph has  $\mu = 4$  and  $f = 4$ , as in figure 3.4.

Let  $G_1$  be an extremal subgraph of  $G$  has  $\mu = 2$  and  $f = 2$ , and  $G_2$  be an extremal subgraph of  $G$  has  $\mu = 2$  and  $f = 2$ , as in figure 3.4. Then  $G_1/(x_1, y_1)$  is an extremal graph having  $\mu = 3$  and  $f = 3$ , and  $G_2/(x_2, y_2)$  is an extremal graph having  $\mu = 3$  and  $f = 3$ . The splitting of the new vertex obtained by identification gives the components of link diagram as it appear in figure 3.8.

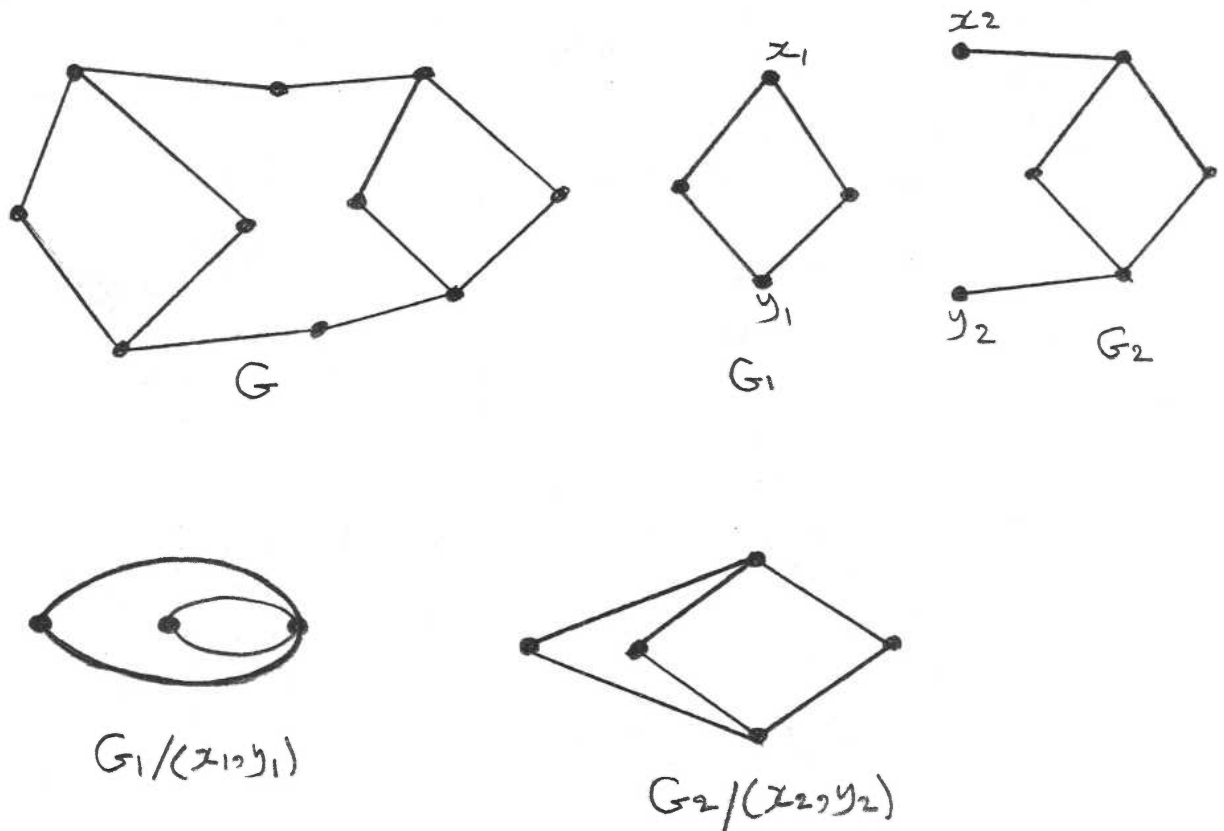

Figure 3.4: The case of an extremal graph without a bridge.  $G_1$  has two distinct vertices each one adjacent to a vertex in  $G_2$  to obtain  $G$ , where the two vertices in  $G_2$  are distinct.

**Theorem 17** *Let  $G$  be a plane graph.  $G$  is extremal if and only if it satisfies one of the following criteria:*

**1**  $G = K_1$

**2**  $G$  has an edge  $e$  whereby  $G \setminus e$  consists of two disjoint extremal graphs.

**3**  $G$  has edges  $e_x = x_1x_2$ ,  $e_y = y_1y_2$  whereby  $G \setminus e_1 \setminus e_2$  consists of two disjoint graphs  $G_1$  and  $G_2$  with  $x_i, y_i \in v(G_i)$  and  $G_i / (x_i, y_i)$  is extremal, for  $i = 1, 2$ .

**Proof**

Denote by  $f$ ,  $f_1$ , and  $f_2$  the numbers of faces of  $G$ ,  $G_1$ , and  $G_2$  respectively. Similarly, denote by  $\mu$ ,  $\mu_1$ , and  $\mu_2$  the numbers of components in their link diagrams. Let  $G$  be an extremal graph, so that  $\mu = f$ , and suppose that  $G$  has at least one edge.

If  $G$  has a bridge  $e$ , then

$$f = f_1 + f_2 - 1,$$

because  $G_1$  and  $G_2$  share a common face. Now by Theorem 2

$$\mu = \mu_1 + \mu_2 - 1.$$

Since  $G$  is extremal

$$\mu_1 + \mu_2 - 1 = \mu = f = f_1 + f_2 - 1.$$

Therefore

$$\mu_1 + \mu_2 - 1 = f_1 + f_2 - 1,$$

which means that

$$\mu_1 + \mu_2 = f_1 + f_2.$$

Since  $\mu_i \leq f_i$  for each  $i$ , we now have

$$\mu_1 = f_1$$

and

$$\mu_2 = f_2$$

as required.

Next, let  $G$  be an extremal graph without a bridge. By Theorem 11 it must have a vertex  $v$  with degree less than 3. However, if  $d(v) = 0$  then  $G = K_1$ , and if  $d(v) = 1$  we have a bridge. So  $d(v) = 2$ . Now there are two cases.

- a** If  $v$  is adjacent to two distinct vertices  $x_1$  and  $y_1$ , as in figure 3.5, then  $x_1 \neq y_1$  in  $G_1$  and  $G_2 = K_1$  (the vertex  $v$ ). Clearly  $\mu_2 = f_2$ . Suppose  $\mu_1$  is the number of components of the link diagram of  $G_1/(x_1, y_1)$ , and  $f_1$  is the number of faces of  $G_1/(x_1, y_1)$ . Then  $\mu_1 = \mu$  and  $f_1 = f$  because the identification of  $x$  and  $y$  does not affect the number of components of the link diagram of  $G_1$  or the number of faces of  $G_1$ , which means that  $G_1/(x_1, y_1)$  is extremal.

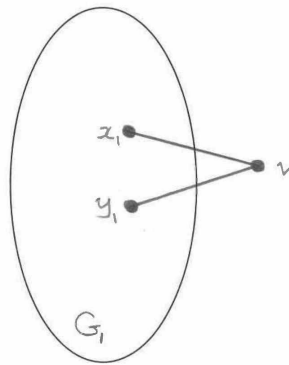

Figure 3.5: The case of an extremal graph without a bridge.  $G_1$  has two distinct vertices adjacent to  $G_2 = K_1$ .

- (b)** If  $v$  is a vertex adjacent twice to another vertex, as in figure 3.6, then  $G_2 = K_1$  as before, and since  $x_1 = y_1$  then  $\mu = \mu_1 + 1$  and  $f = f_1 + 1$ . Since  $G$  is extremal then  $G_1/(x_1, y_1)$  is extremal.

Conversely, suppose that one of the three conditions holds. Then we will show that  $G$  is

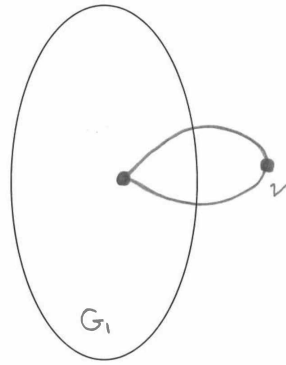

Figure 3.6: The case of an extremal graph without a bridge.  $G_1$  has a vertex adjacent twice to  $G_2 = K_1$ .

extremal.

(1) If  $G = K_1$  then  $G$  is extremal because  $\mu(G) = f(G) = 1$ .

(2) If  $G$  consists of the two extremal graphs  $G_1$ ,  $G_2$  and the bridge  $e$  between them, then  $\mu_1 = f_1$  and  $\mu_2 = f_2$  and since  $e$  is a bridge then  $\mu = \mu_1 + \mu_2 - 1$ . There is a common face between  $G_1$  and  $G_2$ , so  $f = f_1 + f_2 - 1$ , which gives  $f = f_1 + f_2 - 1 = \mu_1 + \mu_2 - 1 = \mu$ . Therefore  $G$  is extremal.

(3) Suppose that the plane graph  $G$  is constructed from two connected plane graphs  $G_1$  and  $G_2$  by adding two new edges  $e_1$  and  $e_2$ , where  $e_1 = (x_1, x_2)$ ,  $e_2 = (y_1, y_2)$  and  $x_i, y_i \in V(G_i)$ , as in figure 3.7. Let  $\mu_i$  be the number of components of the link diagram of  $G_i/(x_i, y_i)$  and  $f_i$  the number of faces of  $G_i/(x_i, y_i)$ . Then

$$f = f_1 + f_2 - 2 \tag{3.7}$$

because we will get two new faces, one in  $f_1$  and another one in  $f_2$ , when we identify  $x_i$  and  $y_i$ . In order to count the components in the various link diagrams, start with  $G_i/(x_i, y_i)$

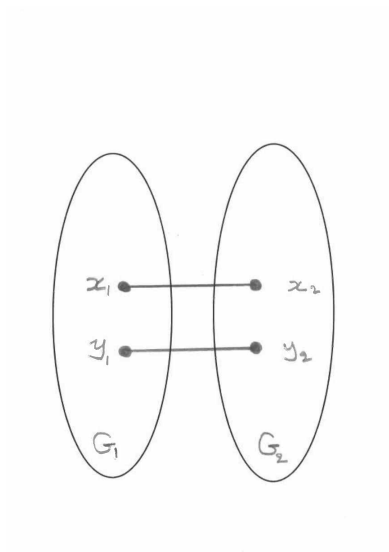

Figure 3.7: A graph  $G$ , constructed from two graphs  $G_1$  and  $G_2$  joined by two edges.

and then “split” the vertices into  $x_i$  and  $y_i$ , obtaining the arrangement shown in figure 3.8.

Hence

$$\mu = \mu_1 + \mu_2 - 2. \quad (3.8)$$

From equations (3.7) and (3.8),  $\mu = f$ . □

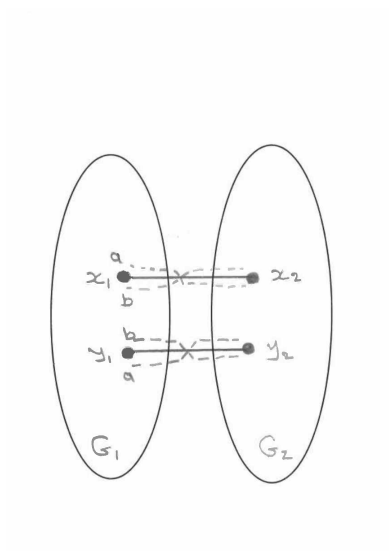

Figure 3.8: The two components  $a$  and  $b$  of a link diagram, moving from  $G_1$  to  $G_2$ .

### 3.3 Two sum and tensor product

This section describes ways of constructing new extremal graphs using the operations of 2-sum and tensor product.

The following two definitions are given in (12) in terms of matroids, but here they are defined for any embedded graph. Let  $G$  and  $H$  be two graphs. Then:

1. If  $G$  and  $H$  have distinguished edges  $a \in E(G)$  and  $b \in E(H)$ , the **2-sum**  $G \oplus_2 H$  is the graph obtained by identifying  $a$  with  $b$  (and hence their end vertices) and deleting this new edge. Note that there may be two different ways of doing this.
2. If  $H$  has a distinguished edge  $b \in E(H)$ , the **tensor product**  $G \otimes H$  is obtained by applying the two sum successively to all edges of  $G$  with  $b \in H$ .

The tensor product of any connected plane graph with a triangle gives a “2-extended” graph, as defined in (21).

**Theorem 18** *Let  $G$  be a connected plane graph, and let  $H$  be a triangle. Then  $G \otimes H$  is extremal.*

**Proof**

By applying Theorem 4 many times to  $G \otimes H$ , we obtain  $K_1$ , which is extremal. Hence by Theorem 16(c)  $G \otimes H$  is extremal. □

The tensor product of any graph  $G$  with  $I_3$  gives a “2-thickening” graph, which is also defined in (21), but this graph is not extremal.

**Theorem 19** *Let  $G$  be an extremal bridgeless graph. Then  $G \otimes I_3$  is not extremal.*

**Proof**

Suppose that  $H = G \otimes I_3$ . Then  $H$  is a graph has an even number of edges between each two adjacent vertices in  $G$ .

Since  $G$  is extremal and bridgless then  $H \setminus \{e_1, e_2\}$  is a connected plane graph, where  $e_1$  and  $e_2$  are two parallel edges in  $H$ . By Theorem 9

$$\mu(D(H)) \leq f(H) - 2.$$

Hence  $H = G \otimes I_3$  is not extremal. □

We can extend Theorem 18 to any odd cycle as in the following theorem. We can prove it by using the same idea of the proof of Theorem 18.

**Theorem 20** *Let  $G$  be any connected plane graph and  $H$  be an odd cycle. Then  $G \otimes H$  is extremal.*

**Proof**

By applying Theorem 4 many times to  $G \otimes H$ , we obtain  $K_1$ , which is extremal. Hence by Theorem 16(c)  $G \otimes H$  is extremal. □

If the distinguished edge in the following theorem is a bridge then the theorem is false.

**Theorem 21** *Let  $G$  be a tree and  $H$  be extremal. Then the tensor product  $G \otimes H$ , in which the distinguished edge in  $H$  is not a bridge, is extremal.*

**Proof**

Suppose  $e$  is not a bridge in  $H$ , and  $H$  is extremal, then by Corollary 16(e)  $H \setminus e$  is extremal.

$G \otimes H$  is a connected plane graph consisting of extremal blocks, each block in  $G \otimes H$  being  $H \setminus e$ . Then by Theorem 16(d)  $G \otimes H$  is extremal. □

The following example shows why  $e \in H$  must not be a bridge in the above theorem.

**Example**

Let  $G$  be a tree of two edges and  $H$  be an extremal graph consisted from two pairs of parallel edges linking by bridge  $b$ , then  $G \otimes H$  on  $b$  is not a connected plane graph, as in the figure 3.9, and it is not extremal. If we choose another edge in  $H$  then  $G \otimes H$  is extremal.

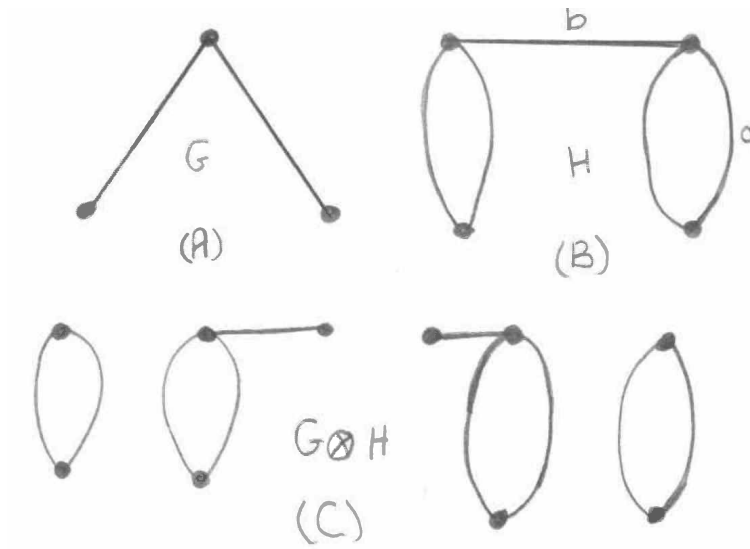

Figure 3.9: Example of the tensor product on a bridge  $b$  of extremal graph.



## Chapter 4

# Extremal graphs on surfaces of genus $g$

This chapter deals with cellularly embedded graphs on a surface of genus  $g$ . Sometimes, we call them *c.e.* graphs.

We use two different cycles in the torus the surface of genus one, which are called the **longitude** and the **meridian**. These two cycles are defined in (24) and are the generators of the first homology group  $\mathbb{Z} \oplus \mathbb{Z}$  of the torus.

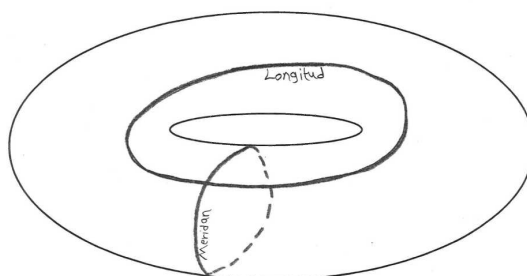

Figure 4.1: The generators of the first homology group  $\mathbb{Z} \oplus \mathbb{Z}$  on the torus.

### 4.1 Connected graphs

A cellularly embedded graph  $\psi$  of one face is called a **pseudo-tree**. The spanning subgraph of a cellularly embedded graph  $G$  is a pseudo-tree. In chapter two we proved that  $\mu(D(T)) = 1$  where  $T$  is a tree, but in the next proof we show that

$$\mu(D(\psi)) \leq 3,$$

where  $\psi$  is a pseudo-tree embedded on the torus.  $\psi$  embedded on the torus can have two cycles around the handle which is not bounding a disc. The following example has two diagrams one for a pseudo-tree and another one for an embedded graph which is not a pseudo-tree.

### Example

Figure 4.2 show us an example and non-example of a pseudo-tree.

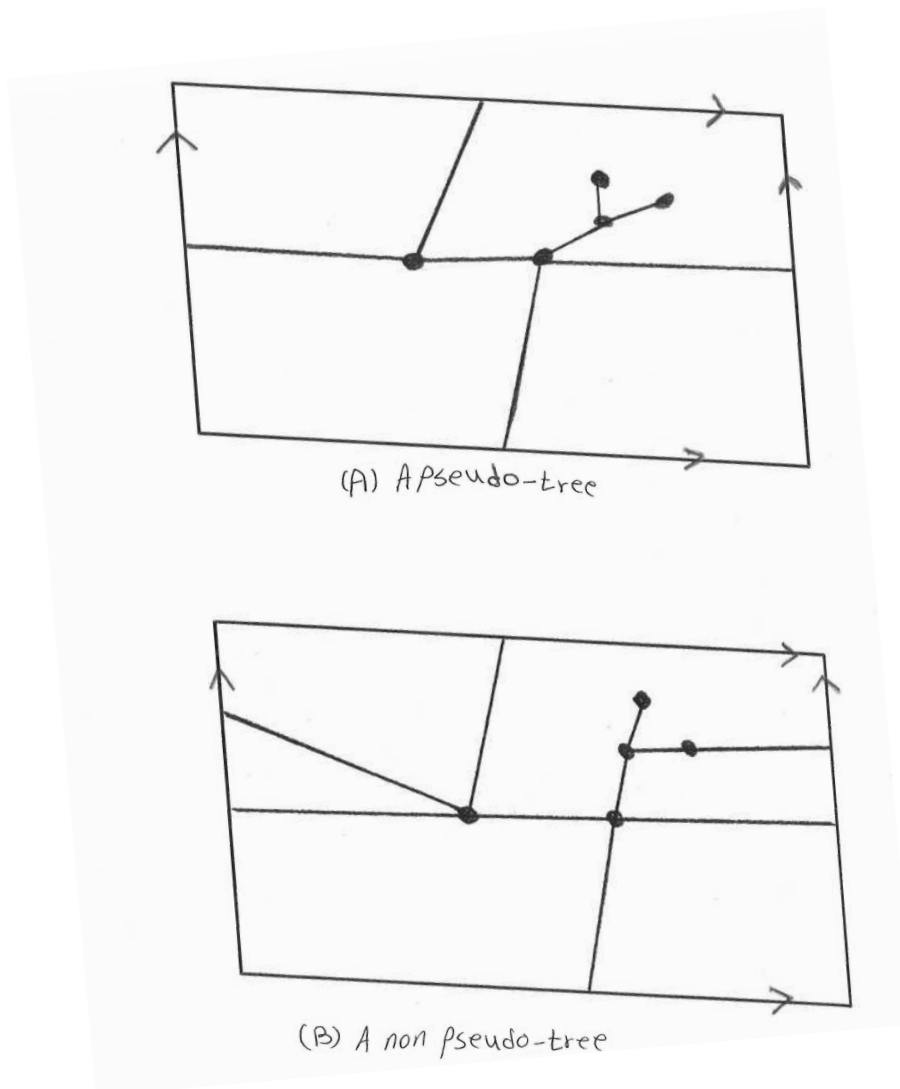

Figure 4.2: (A) is a diagram for a pseudo-tree, and (B) is a diagram for a cellularly embedded graph which is not a pseudo-tree.

**Theorem 22** Let  $\psi$  be a pseudo-tree on the torus. Then

$$\mu(D(\psi)) \leq 3.$$

**Proof**

There are several steps in this proof.

- 1 In this step each bridge, and each pair of non-parallel edges incident with a common vertex of degree two, are contracted. From Theorem 3 and Theorem 4, this step constructs a graph  $\lambda$ , with one face and the same number of components of a link diagram as  $\psi$ .
- 2 Since  $\lambda$  is got by contracting edges, which is a purely local operations on  $\psi$ , then these contractions preserve faces bound discs. Therefore  $\lambda$  is a cellularly embedded graph on the torus, and so it must have at least one meridian cycle and one longitude cycle. If  $\lambda$  had two or more meridian cycles, then it would have two or more faces, and this is a contradiction. So it has just one meridian cycle. Similarly, it has just one longitude cycle.
- 3 Let  $M$  and  $L$  denote the meridian and longitude cycles, and let  $p$  and  $q$  be the end vertices of the path  $M \cap L$ . If  $M \cap L$  were not connected then there would be more than one longitude or meridian. If  $\lambda$  has more than one longitude or meridian that makes new faces bound discs, which is a contradiction.
- 4 We show that each vertex in  $\lambda$  has degree 2, except for  $p$  and  $q$  which have degree 3 or 4. By step 1  $M \cap L$  is either one vertex or a path of one edge, because more than one edge in this path would allow for further contractions. If  $M \cap L$  is one vertex then  $p = q$ . If the degree of  $p$  were more than four then there would be at least five edges incident with  $p$ . Four of these five edges are accounted for: two for  $M$  and two for  $L$ . The fifth edge, if it exists, cannot be a bridge because of step 1, so it must be connected with another part of  $\lambda$ , which makes a second face, which is a contradiction. If  $M \cap L$  is a path of one edge then the degrees of  $p$  and  $q$  are three. Otherwise, we arrive at the same contradiction as in the previous case. Also for this reason, any another vertex in  $\lambda$  must be of degree two.
- 5 Suppose  $\lambda$  contained more than three vertices. In this case we can find pairs of edges,

each pair incident with a common vertex of degree two. But in step 1 we removed all such pairs.

6 There are just four possible graphs  $\lambda$ , as in figure 4.3. □

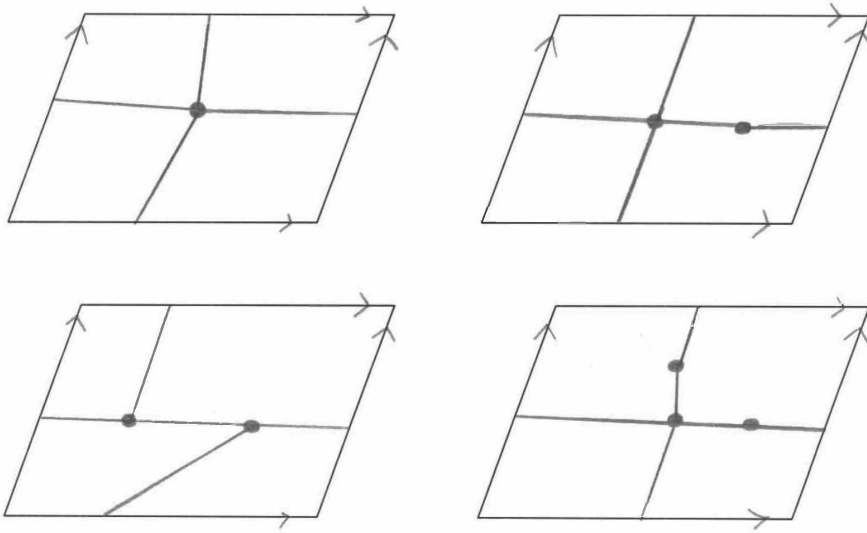

Figure 4.3: Just these four diagrams of  $\lambda$  satisfy Theorem 22.

Theorem 23 is a most important theorem. It gives an upper bound for the number of components of the link diagram of a pseudo-tree embedded in the surface of genus  $g$ . This number depends on  $g$ .

**Theorem 23** *Let  $\psi$  be a pseudo-tree embedded on a surface of genus  $g$ . Then  $\mu(D(\psi)) \leq 1 + 2g$ .*

### Proof

We are going to complete the proof by induction on the number of genus.

Suppose that  $g = 0$ . Then by Theorem 1  $\mu(D(\psi)) \leq 1$ ;  $\psi$  here is a tree.

Let  $\psi_i$  be a pseudo-tree embedded in a surface  $S_i$  of genus  $g$ , we have  $\mu(D(\psi_i)) \leq 1 + 2g$ .

Let  $S_{i+1}$  be a surface of genus  $g + 1$ , and  $\psi_{i+1}$  be a pseudo-tree embedded in  $S_{i+1}$ . We are going to prove:

$$\mu(D(\psi_{i+1})) \leq 1 + 2(g + 1) = 3 + 2g.$$

This means that we will prove that  $\psi_{i+1}$  has at most two more components than  $\psi_i$ .

Consider one of the handles of  $S_{i+1}$ , and let  $L$  and  $M$  be the longitude and meridian cycles in  $\psi_{i+1}$  for this handle, see figure 4.4.

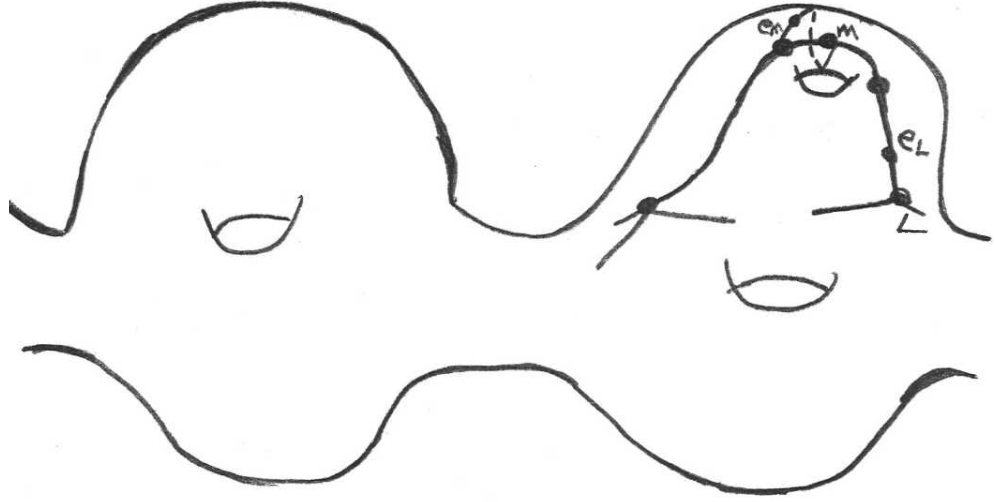

Figure 4.4:  $L$  is the new longitude cycle and  $M$  is the new meridian cycle of  $S_{i+1}$  surface, where  $e_L$  is an edge in  $L$ , but not in  $M$ .  $e_M$  is an edge in  $M$  not in  $L$ .

Choose one edge  $e_L$  in  $L$ , but not in  $M$ , and then delete this edge. By Theorem 7

$$\mu(D(\psi_{i+1})) \leq \mu(D(\psi_{i+1} \setminus e_L)) + 1.$$

Repeat the same process with  $M$  by choosing one edge  $e_M$  in  $M$ , but not in  $L$ , and we get

$$\mu(D(\psi_{i+1})) \leq \mu(D(\psi_{i+1} \setminus e_M)) + 1.$$

These two deletions yield a graph which is no longer  $\psi$  a pseudo-tree on  $S_{i+1}$ , but is a pseudo-tree on the surface of genus  $g$  obtained from  $S_{i+1}$  by removing the handle under consideration, as in figure 4.5. This gives

$$\mu(D(\psi_{i+1})) \leq \mu(D(\psi_i)) + 2.$$

□

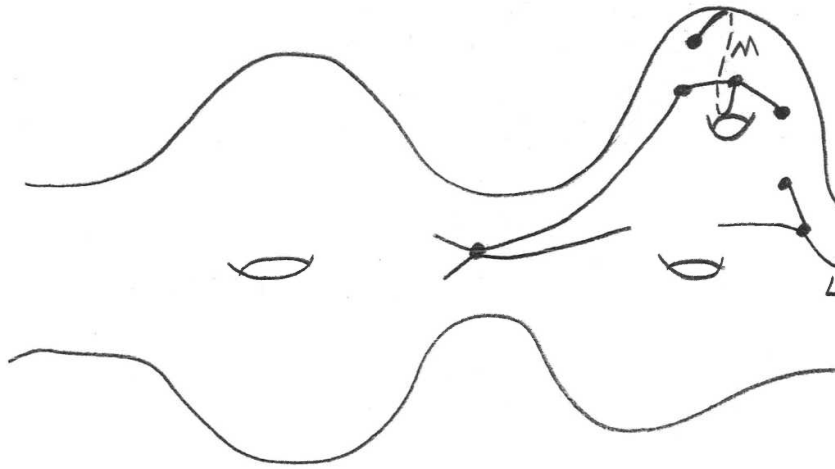

Figure 4.5:  $\psi_{i+1} \setminus e_M \setminus e_L$ .

The following theorem finds an upper bound for the number of components of a link diagram in a cellularly embedded graph by finding the relationship between the number of components of the link diagram and the number of faces in any *c.e.* graph.

**Theorem 24** *Let  $G$  be a cellularly embedded graph on a surface of genus  $g$ . Then*

$$1 \leq \mu(D(G)) \leq f(G) + 2g.$$

**Proof**

Suppose that  $G$  is a cellularly embedded graph in the surface of  $g = 0$ . Then  $G$  is a connected plane graph, and by Theorem 8

$$1 \leq \mu(D(G)) \leq f(G) + 2g.$$

The theorem holds.

If this theorem is correct for any cellularly embedded graph in a surface of genus  $g - 1$ , then assume  $G$  is a cellularly embedded graph in surface  $S$  of genus  $g$ . Now we need to

prove that

$$1 \leq \mu(D(G)) \leq f(G) + 2g.$$

Let  $\psi$  be a spanning pseudo-tree of  $G$ , where  $\psi$  is a cellularly embedded graph with one face. Then by Theorem 23

$$\mu(D(\psi)) \leq 1 + 2g$$

This means the theorem holds, because  $\psi$  has one face. One by one, edges are added to  $\psi$  in order to get  $G$ . This insertion increases the number of faces by exactly one each time, because each new edge joins two vertices in  $\psi$ , where we have two types of new edges one when this edge is round a disc and it is clear there is a new face, another type when this edge is around a handle the new face would be bounded between two meridian or longitude cycles. Then this addition of edges gives the following sequence of graphs embedded in  $S$ .

$$G_0 = \psi, G_1, \dots, G_{s-1}, G_s = G.$$

So when  $i = 0, \dots, s-1$

$$f(G_{i+1}) = f(G_i) + 1 = f(G_0) + i + 1 = f(\psi) + i + 1,$$

and

$$\mu(D(G_{i+1})) \leq \mu(D(G_i)) + 1 \tag{4.1}$$

$$\leq \mu(D(G_0)) + i + 1. \tag{4.2}$$

Since  $\mu(D(G_0)) \leq f(G_0) + 2g$ , we have

$$\mu(D(G_{i+1})) \leq \mu(D(G_0)) + i + 1 \tag{4.3}$$

$$\leq f(G_0) + 2g + i + 1 \tag{4.4}$$

$$\leq f(G_{i+1}) + 2g. \tag{4.5}$$

$$\mu(D(G_{i+1})) \leq f(G_{i+1}) + 2g$$

for each  $i$ , which means that

$$\mu(D(G)) \leq f(G) + 2g.$$

□

We use the fact of  $v(G) = f(G^*)$  again in a *c.e.* graph to prove the following corollary:

**Corollary 6** *Let  $G^*$  be a cellularly embedded graph on a surface of genus  $g$ , then*

$$\mu(D(G)) \leq v(G) + 2g.$$

**Proof**

By Theorem 24

$$\mu(D(G^*)) \leq f(G^*) + 2g,$$

$$f(G^*) = v(G),$$

and

$$\mu(D(G)) = \mu(D(G^*)),$$

then

$$\mu(D(G)) \leq v(G) + 2g.$$

□

$$\mu(D(G)) = f(G) + 2g$$

is impossible in the case of any graph containing parallel edges bounding a disc, where deleting this pair of parallel edges will produce a connected graph. This case will be proved in next theorem.

**Theorem 25** *Let  $G$  be a cellularly embedded graph on a surface of genus  $g$  with a pair of parallel edges  $a$  and  $b$ . If  $a$  and  $b$  bound a disc and  $G \setminus a \setminus b$  is a cellularly embedded*



graph, then

$$\mu(D(G)) \leq f(G) + 2g - 2.$$

**Proof**

If  $a$  and  $b$  are parallel edges bounding a disc, and  $G \setminus a \setminus b$  is a cellularly embedded, then by Theorem 24

$$\mu(D(G)) \leq f(G) + 2g$$

and

$$\mu(D(G \setminus a \setminus b)) \leq f(G \setminus a \setminus b) + 2g,$$

but

$$f(G) = f(G \setminus a \setminus b) + 2,$$

which means that

$$\mu(D(G)) = \mu(D(G \setminus a \setminus b)) \leq f(G \setminus a \setminus b) + 2g = f(G) - 2 + 2g.$$

□

## 4.2 Extremal graph

If  $G$  is a cellularly embedded graph on a surface of genus  $g$ , then  $G$  is called **extremal** if

$$\mu(D(G)) = f(G) + 2g.$$

Theorem 25 helps us to distinguish some properties of extremal graphs as in the following theorem:

**Theorem 26** *Let  $G$  be extremal, with a pair of parallel edges  $a$  and  $b$  bounding a disc. Then  $G \setminus a \setminus b$  is not a cellularly embedded graph.*

**Proof**

Suppose  $G$  has a pair of parallel edges bounding a disc ( $a$  and  $b$ ), and  $G \setminus a \setminus b$  is a cellularly embedded graph. By Theorem 25

$$\mu(D(G)) \leq f(G) + 2g - 2,$$

but this is a contradiction because  $G$  is extremal and

$$\mu(D(G)) = f(G) + 2g.$$

□

The same argument as in Theorem 16 is used in the following theorem.

**Theorem 27** *Let  $G$  be a graph cellularly embedded in a surface of genus  $g$ . Then the following statements are true.*

- a** *Let  $e$  be a bridge of  $G$ . Then  $G/e$  is extremal if and only if  $G$  is extremal.*
- b** *Let  $v$  be a vertex of degree 2 with exactly one adjacent vertex with these two edges bounding a disc. Then  $G \setminus v$  is extremal if and only if  $G$  is extremal.*
- c** *Let  $v$  be a vertex of degree 2 with distinct adjacent vertices  $x$  and  $y$ . Then  $G/(v,x)/(v,y)$  is extremal if and only if  $G$  is extremal.*
- d** *See Conjecture 1 in Chapter 7.*
- e** *Let  $G$  be extremal and  $e$  not an internal edge in  $G$ . Then  $G \setminus e$  is extremal.*

**Proof**

- a** We use the same method of proof as in (a) in Theorem 16.
- b** We use the same method of proof as in (b) in Theorem 16.
- c** We use the same method of proof as in (c) in Theorem 16.

$e$  Since  $e$  is not an internal edge,  $G \setminus e$  is a cellularly embedded graph and

$$f(G) = f(G \setminus e) + 1.$$

By Theorem 7

$$\mu(D(G)) \leq \mu(D(G \setminus e)) + 1,$$

but

$$\mu(D(G)) = f(G) + 2g = f(G \setminus e) + 2g + 1,$$

and so

$$\mu(D(G \setminus e)) \geq f(G \setminus e) + 2g,$$

and hence  $G \setminus e$  must be extremal. □

The following lemma has a role in the proofs of many of our later theorems.

**Lemma 4** *Let  $G$  be extremal. Then a component of  $D(G)$  only ever crosses itself on a bridge of  $G$ .*

**Proof**

Suppose  $e$  is an edge in  $G$ , not an internal edge, and suppose a component of  $D(G)$  crosses itself on this edge.

By Theorem 27- $e$ ,  $G \setminus e$  is extremal.

When we delete  $e$  we get two arcs  $\alpha_1$  and  $\alpha_2$  at the end vertices  $v_1$  and  $v_2$  of  $e$ . There are two cases:

**Case 1.** If  $\alpha_1 \neq \alpha_2$  then the number of components of a link diagram has increased but the number of faces has dropped. This is impossible because  $G \setminus e$  is extremal.

**Case 2.** If  $\alpha_1 = \alpha_2$  then

$$\mu(D(G)) = \mu(D(G \setminus e)),$$

and

$$f(G) = f(G \setminus e) + 1,$$

but this is a contradiction because  $G \setminus e$  is extremal.  $\square$

Now, we can show that no extremal graph has a loop bounding a disc.

**Corollary 7** *Let  $G$  be extremal. Then  $G$  does not have a loop bounding a disc.*

**Proof**

If  $G$  had a loop bounding a disc, then  $G$  would have an edge on which a component of  $D(G)$  crosses itself.  $\square$

**Theorem 28** *Let  $G$  be extremal and  $\psi$  be a spanning pseudo-tree of  $G$ . Then  $\psi$  is extremal.*

**Proof**

Since  $G$  is extremal

$$\mu(D(G)) = f(G) + 2g \dots (1)$$

If one edge  $e$  on  $G$  is deleted, where  $e$  is not an internal edge, then

$$f(G \setminus e) = f(G) - 1 \dots (2),$$

and by Theorem 7

$$\mu(D(G \setminus e)) \geq \mu(D(G)) - 1.$$

By (1) and (2)

$$\begin{aligned} \mu(D(G \setminus e)) &\geq f(G) + 2g - 1, \\ &\geq f(G \setminus e) + 1 + 2g - 1, \\ &\geq f(G \setminus e) + 2g. \end{aligned}$$

By Theorem 24

$$\mu(D(G \setminus e)) > f(G \setminus e) + 2g$$

is impossible, and so

$$\mu(D(G \setminus e)) = f(G \setminus e) + 2g.$$

Hence by Theorem 27-e deleting any edge  $e$  from  $G$  which is not an internal edge which keeps  $G \setminus e$  a cellularly embedded graph gives an extremal graph.

If we continue with this operation we will get a sequence of extremal graphs

$$\psi = G_0, G_1, \dots, G_s = G,$$

where  $G_0$  is a spanning pseudo-tree  $\psi$ . □

We suppose  $\mu(v)$  is the number of components of a link diagram which pass close (this means the local arcs of the components of a link diagram on the neighbours of  $v$ ) to  $v$ . The following proof deals with an internal edge, an **internal edge** is an edge incident with only one face. The next theorem gives a local consequence of  $G$  being extremal. Before the proof we would like to clarify the meaning of the internal edge through the following example.

### Example

The diagram on figure 4.6

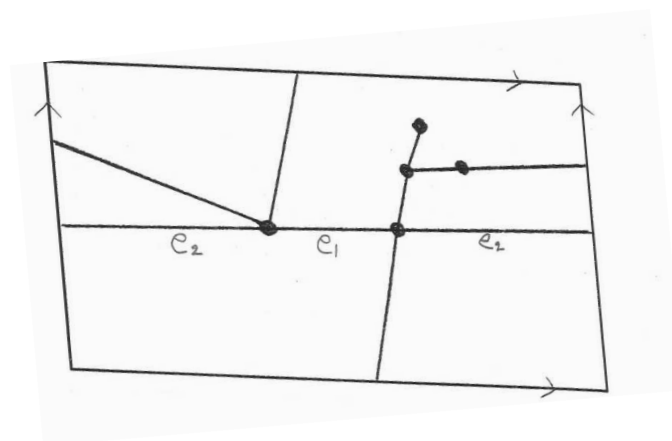

Figure 4.6:  $e_1$  is an internal edge, where  $e_2$  is not a internal edge.

**Theorem 29** Let  $G$  be an extremal graph and  $v \in V(G)$  not a cut-vertex. Then  $d(v) = \mu(v)$ .

**Proof**

Note that in any case  $d(v) \geq \mu(v)$ .

Suppose  $d(v) > \mu(v)$ , where  $v$  is one end vertex of the edge  $e$  in  $G$ . We also suppose that  $v$  is not a cut vertex, and that  $e$  is not an internal edge (so that  $G \setminus e$  is still cellularly embedded). Let

$$G_0 = \psi, \dots, G_s = G,$$

be the sequence of extremal graphs arising from the previous theorem.

Suppose that arcs  $\alpha$  and  $\beta$  in figure 4.7 come from the same component of a link diagram. If one edge is deleted, we will get an extremal graph. When we continue with

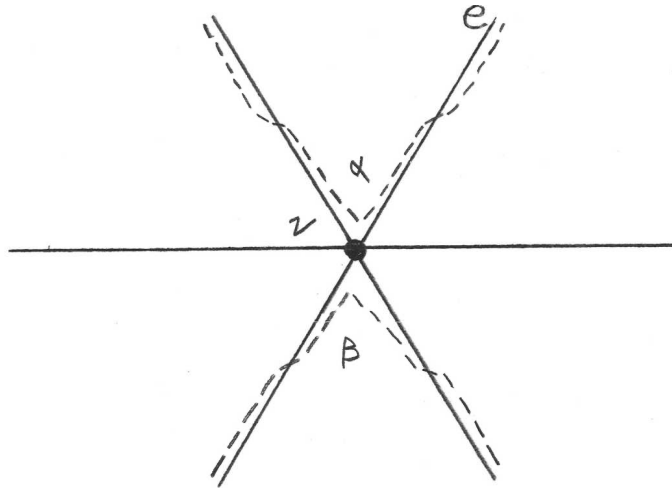

Figure 4.7:  $\alpha$  and  $\beta$  are arcs coming from the same component of a link diagram and passing close to vertex  $v$ .

this deletion of the edges, we will get the case of edge  $e$  where the component of a link diagram crosses itself. If  $e$  is deleted then the number of faces decreases, as in figure 4.8, but the number of components of a link diagram remains unchanged. By Theorem 27-e this is a contradiction. Therefore this graph will not be extremal.  $\square$

### 4.3 Torus theorems

Theorem 22 and Theorem 28 allow to us to take into consideration the intersection path between a longitude cycle and a meridian cycle in an extremal graph which is cellularly

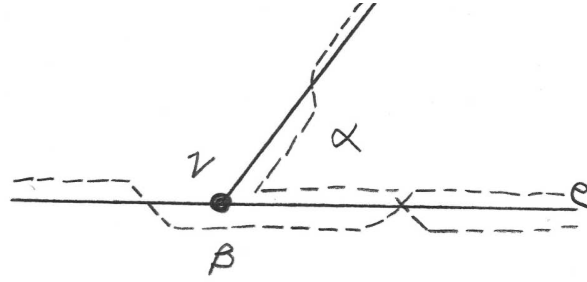

Figure 4.8:  $\alpha$  and  $\beta$  are arcs of the same component of a link diagram passing close to vertex  $v$  and crossing at edge  $e$ .

embedded on the torus. A **length of path** is the number of edges on a path.

**Theorem 30** *Let  $G$  be an extremal graph on the torus. Then each longitude cycle and meridian cycle intersect in a path  $P$  with odd length.*

### Proof

Let  $P$  be the intersection of a longitude cycle and a meridian cycle in  $G$ . Suppose  $P$  has an even number of edges, then we have several cases to consider.

**Case (1)** : Suppose  $P$  has zero length, which means that  $M \cap L = \{v_1\}$ , where  $v_1 \in V(G)$ .

Then there is a spanning pseudo-tree of  $G$  having a path of zero length. If we make all possible contraction we obtain  $\lambda$  which is one graph in figure 4.9. This  $\lambda$  has a zero path of  $M \cap L$  which is not extremal, then by Theorem 28 this is a contradiction.

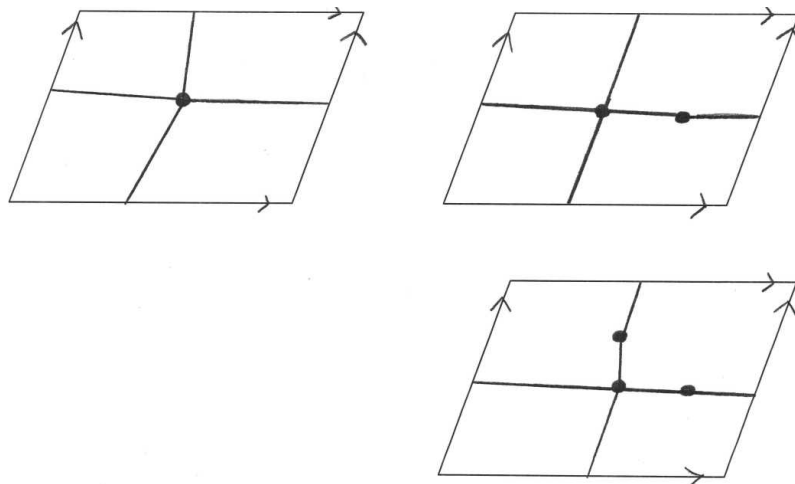

Figure 4.9: Types of  $\lambda$  which are not extremal.

**Case (2)** : Suppose  $P$  is a path of length two, then  $P$  contains three vertices. Let the middle vertex be  $v$ . Then there are two possibilities:

- (a) If  $v$  is a vertex of degree 2, then by Theorem 4  $P$  has zero length. By Theorem 28 this is a contradiction, as in Case (1).
- (b) If the degree of  $v$  is greater than two and there is a bridge incident with  $v$  which is not in  $P$ , then by Theorem 27-a we can contract this bridge and get a new torus extremal graph.

Now if there is an edge incident from  $v$  which is not a bridge, then by Theorem 27-e when this edge is deleted the new graph is an extremal graph.

We continue with these contractions and deletions in order to get a case of  $v$  with degree 2, which is a contradiction as we have already seen.

**Case (3)** Suppose  $P$  is a path of length  $n - 1$ , where  $n$  is the number of vertices of  $P$ .

For any internal vertex of  $P$  of degree greater than 2, we can proceed as in Case (2).

□

We can distinguish the extremal graph on the torus through the longitude cycle and meridian cycle.

**Theorem 31** *The meridian and longitude cycles in an extremal graph are even.*

**Proof**

Suppose  $G$  is an extremal graph with an odd meridian cycle. By Theorems 27-(e) edges are deleted in order to get a spanning pseudo-tree *with* this meridian cycle, which is not extremal. Because by Theorems 3 and 4 the new pseudo-tree has a zero length of path. Then by Theorems 30 and 28 this is a contradiction. □

**Corollary 8** *There is no loop in any of the extremal graphs embedded on the torus.*



**Proof**

Since  $G$  is extremal, then by Corollary 7  $G$  does not have a loop bounding a disc. Since  $G$  is extremal, then by Theorem 31  $G$  does not have an odd meridian or longitude cycle. Since any loop is an odd cycle then  $G$  does not have a loop which not bounding a disc. □



# Chapter 5

## Graphs with $\mu = 1$

In this chapter we are going to study the case of embedded graphs with the minimum number of components of a link diagram,  $\mu(D(G)) = 1$ . We try to discover as many such graphs as possible.

### 5.1 Reidemeister 2 moves

The most obvious graphs with  $\mu = 1$  are the trees and the odd cycles. We have proved that trees have  $\mu = 1$ . Now we need to prove that odd cycles  $\mu = 1$ .

**Theorem 32** *Every odd cycle has  $\mu = 1$ .*

#### Proof

Suppose  $O$  is an odd cycle.

If  $O$  is a loop then the theorem holds.

If  $O$  has more than two edges, then contract each pair of adjacent edges. By Theorem 4 this process does not change the number of components of a link diagram of the original graph. We obtain a loop. Hence the theorem holds.  $\square$

The dual graph of the odd cycle is a graph consisting of an odd number of parallel edges, it is  $I_n$  with  $n$  odd number. This fact helps us to find another case of a graph with one component of a link diagram.

**Theorem 33** *For any odd positive integer  $n$ ,  $\mu(D(I_n)) = 1$ .*

**Proof**

Since the dual graph of  $I_n$  is an odd cycle and  $\mu(D(I_n)) = \mu(D(I_n^*))$ , then by Theorem 32  $\mu(D(I_n)) = 1$ .  $\square$

By deleting a pair of parallel edges or contracting a pair of edges incident with a vertex of degree two in a graph, we do not change  $\mu$ . Hence the following theorem

**Theorem 34** *Let  $G$  be an embedded graph with  $\mu = 1$ . If  $a_1$  and  $a_2$  are parallel edges  $a$  and  $b$  bounding a disc, then*

$$\mu(D(G \setminus a_1 \setminus a_2)) = 1.$$

*If  $b_1$  and  $b_2$  are edges incident with a common vertex of degree 2, then*

$$\mu(D(G/b_1/b_2)) = 1.$$

**Proof**

This follows from Theorem 4 and Theorem 5.  $\square$

The next theorems are consider the 2-sum. We can not use any graph containing one component in the link diagram in this theorem because this case is not guaranteed with any graph has  $\mu = 1$  just with cycles.

**Theorem 35** *Let  $G$  be a cycle and  $H$  be  $I_n$  where  $n$  is odd and each pair of parallel edges of  $I_n$  bounds a disc. Then*

$$\mu(D(G \oplus_2 H)) = 1.$$

**Proof**

Graph  $G \oplus_2 H$  has even number of parallel edges arising from  $I_n$ . If Theorem 5 applies many times and all these pairs of parallel edges are deleted, then we get a tree. Hence, the theorem holds.  $\square$

In the next theorem we can use any graph with  $\mu = 1$ , but the  $n$  in  $I_n$  has to be even.

**Theorem 36** *Let  $G$  be a graph with  $\mu(D(G)) = 1$  and  $H$  be  $I_n$ , where  $n$  is an even number and each pair of parallel edges in  $I_n$  bounds a disc. Then  $\mu(D(G \oplus_2 H)) = 1$ .*

**Proof**

When each pair of parallel edges of  $G \oplus_2 H$  in the distinguished edge (this means just in graph  $G \oplus_2 H$ , but not in graph  $G$ ) is deleted, this work gives a graph  $G$ . Then by Theorem 5

$$\mu(D(G \oplus_2 H)) = \mu(D(G)) = 1$$

□

The following theorem is true because  $(G \oplus_2 I_n)^* = G^* \oplus_2 C_n$ . Where  $C_n$  is a cycle and  $I_n$  is a dual graph of  $C_n$ .

**Theorem 37** *Let  $G$  be a graph with  $\mu(D(G)) = 1$  and  $H$  be an even cycle. Then  $\mu(D(G \oplus_2 H)) = 1$ .*

**Proof**

Suppose  $e \in G$  and  $e = (v_1, v_2)$ , graph  $G \oplus_2 H$  on edge  $e$ . Then  $e$  on graph  $G \oplus_2 H$  becomes an odd path. If each pair of edges in this path is contracted, then we get graph  $G$ . Hence the theorem holds. □

## 5.2 Connected sum

The connected sum of knots is the composition of knots. This composition is the link diagram of a graph consists of blocks. In this section we restrict Theorem 2 to the case of graph consists of blocks, where each block has  $\mu = 1$ .

**Theorem 38** *Let  $G$  be a connected embedded graph. Then  $\mu(D(G)) = 1$  if and only if  $\mu(D(B_i)) = 1$  for  $i = 1, \dots, k$ , where  $\{B_i\}_{i=1}^k$  is the set of all the blocks comprising  $G$ .*

**Proof**

Firstly, let  $\mu(D(G)) = 1$ . Then by Theorem 2

$$1 = \sum_{i=1}^k \mu(D(B_i)) - k + 1,$$

which means that  $\sum_{i=1}^k \mu(D(B_i)) = k$ . Now  $\mu(D(B_i)) \geq 1$ , and hence  $\mu(D(B_i)) = 1$ .

Secondly, if  $\mu(D(B_i)) = 1$  for each  $i = 1, \dots, k$ , then by Theorem 2

$$\mu(D(G)) = k - k + 1 = 1$$

□

We can use Theorem 38 to study the case of a graph whose blocks are trees or odd cycles.

**Theorem 39** *Let  $G$  be a graph whose blocks are trees or odd cycles. Then  $\mu(D(G)) = 1$ .*

**Proof**

Let  $G$  be a graph whose blocks are trees or odd cycles. By Corollary 1 each tree  $T$  has  $\mu(D(T)) = 1$ , and by Theorem 32 each odd cycle  $O$  has  $\mu(D(O)) = 1$ . Then by Theorem 38

$$\mu(D(G)) = 1.$$

□

**Theorem 40** *Let  $G$  and  $H$  be graphs with  $\mu(D(G)) = \mu(D(H)) = 1$ , and let  $H$  have a vertex  $v$  of degree one. If  $v$  is identified with any vertex in  $G$ , the new graph  $F$  has  $\mu(D(F)) = 1$ .*

**Proof**

$F$  has three blocks:  $B_1 = G$ ,  $B_2 = H \setminus v$ , and  $B_3 = K_2$ . Each of these blocks has  $\mu = 1$ .

□

### 5.3 Reidemeister 3 moves

Since the embedded  $\Delta - Y$  exchanges for any graph do not alter the value of  $\mu$ , we have the following theorem.

**Theorem 41** *Let  $G$  and  $H$  be related by embedded  $\Delta - Y$  exchanges and  $\mu(D(G)) = 1$ . Then  $\mu(D(H)) = 1$ .*

### 5.4 Other moves

In the following theorem we have a case of  $\mu(D(G+e)) = 1$  where  $\mu(D(G)) = 1$  and  $e$  is a new edge added to  $G$  to get the new graph.

**Theorem 42** *Let  $G$  be a graph with  $\mu(D(G)) = 1$ ,  $v_1, v_2 \in V(G)$  are two different vertices and the component of a link diagram of  $G$  is organised as in figure 5.1. Then a new edge joins  $v_1$  and  $v_2$  does not change the number of components of a link diagram.*

#### Proof

This theorem is case 2a in Theorem 7. □

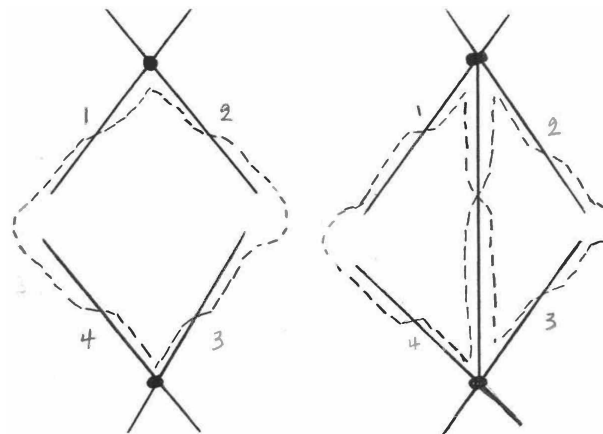

Figure 5.1:  $\mu(D(G+e)) = 1$ , if the endpoints of the arcs  $\alpha_1$  and  $\alpha_2$  come in the order 1,2,3,4 in the component of a link digram of  $G$ , where  $\mu(D(G)) = 1$ .





# Chapter 6

## Petersen family and Heawood family

In this chapter we work with two interesting families of graphs. These families have a constant value of the number of components of the link diagrams, neither the maximum nor the minimum. The first family is Petersen family  $\mathcal{P}$  and the second is Heawood family  $\mathcal{H}$ . All the graphs in these two families are embedded in the torus.

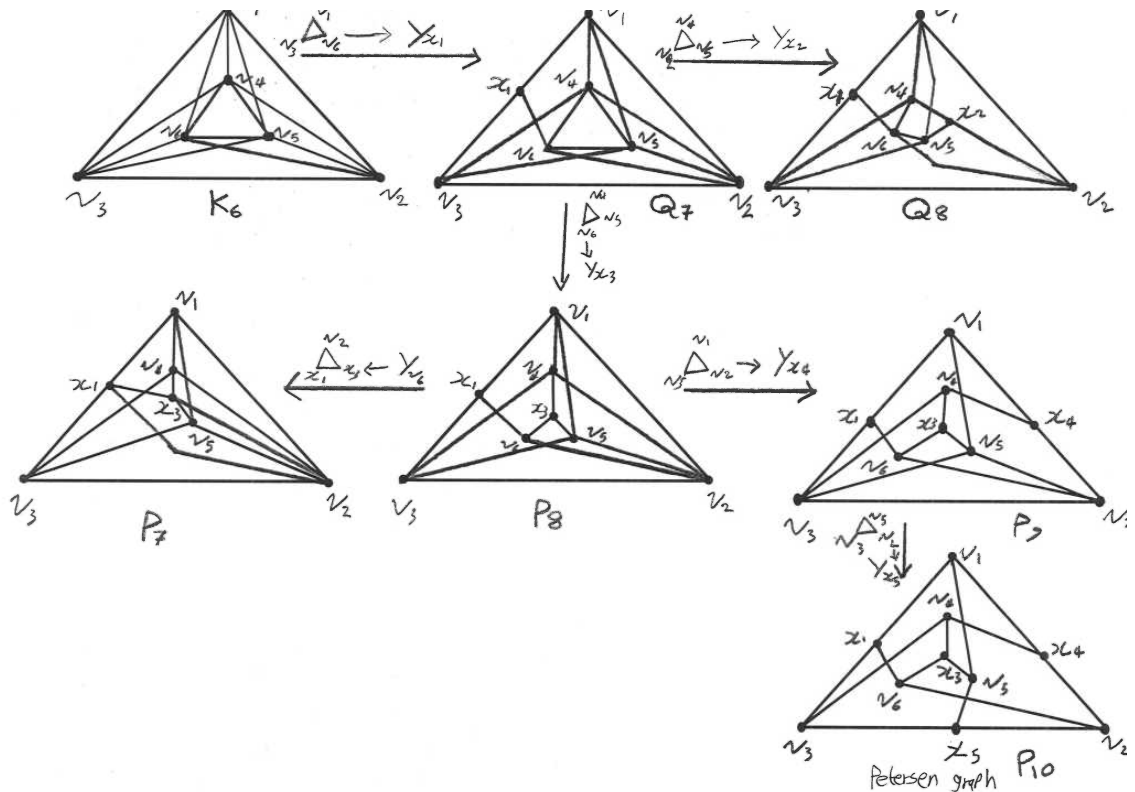

Figure 6.1: The Petersen family

Each graph in  $\mathcal{P}$  can be obtained from  $K_6$  by a finite sequence of abstract  $Y \rightarrow \Delta$  or

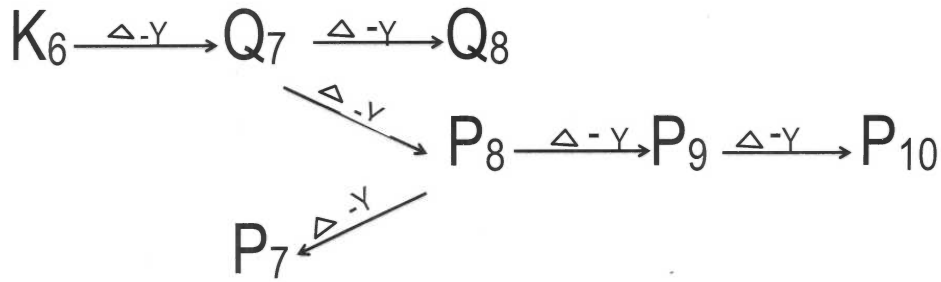

Figure 6.2: The Petersen family scheme.

$\Delta \rightarrow Y$  exchanges, figure 6.1.

This set  $\mathcal{P}$  contains exactly seven graphs. Note that:

1. There are five elements of this family obtainable from  $K_6$  by  $\Delta \rightarrow Y$  exchanges only.
2. One of these five graphs, which contains ten vertices, is called the **Petersen graph**.
3.  $K_{3,3,1}$  is an element of this family. It is derived from  $K_6$  by two  $\Delta \rightarrow Y$  exchanges and one  $Y \rightarrow \Delta$  exchange.

The set of all graphs that can be obtained from  $K_7$  by finite sequences of abstract  $Y \rightarrow \Delta$  or  $\Delta \rightarrow Y$  exchanges is the **Heawood family**  $\mathcal{H}$ , figure 6.3.

This set contains exactly twenty graphs. Note that:

1. There are fourteen elements of this family reached from  $K_7$  by  $\Delta \rightarrow Y$  exchanges.
2. One of these fourteen graphs, which contains fourteen vertices, is called the **Heawood graph**.
3. Another six graphs of this family are obtained from  $K_7$  by  $\Delta \rightarrow Y$  exchanges and  $Y \rightarrow \Delta$  exchanges.

We have used the graph names for  $\mathcal{P}$  and  $\mathcal{H}$  given in (8).

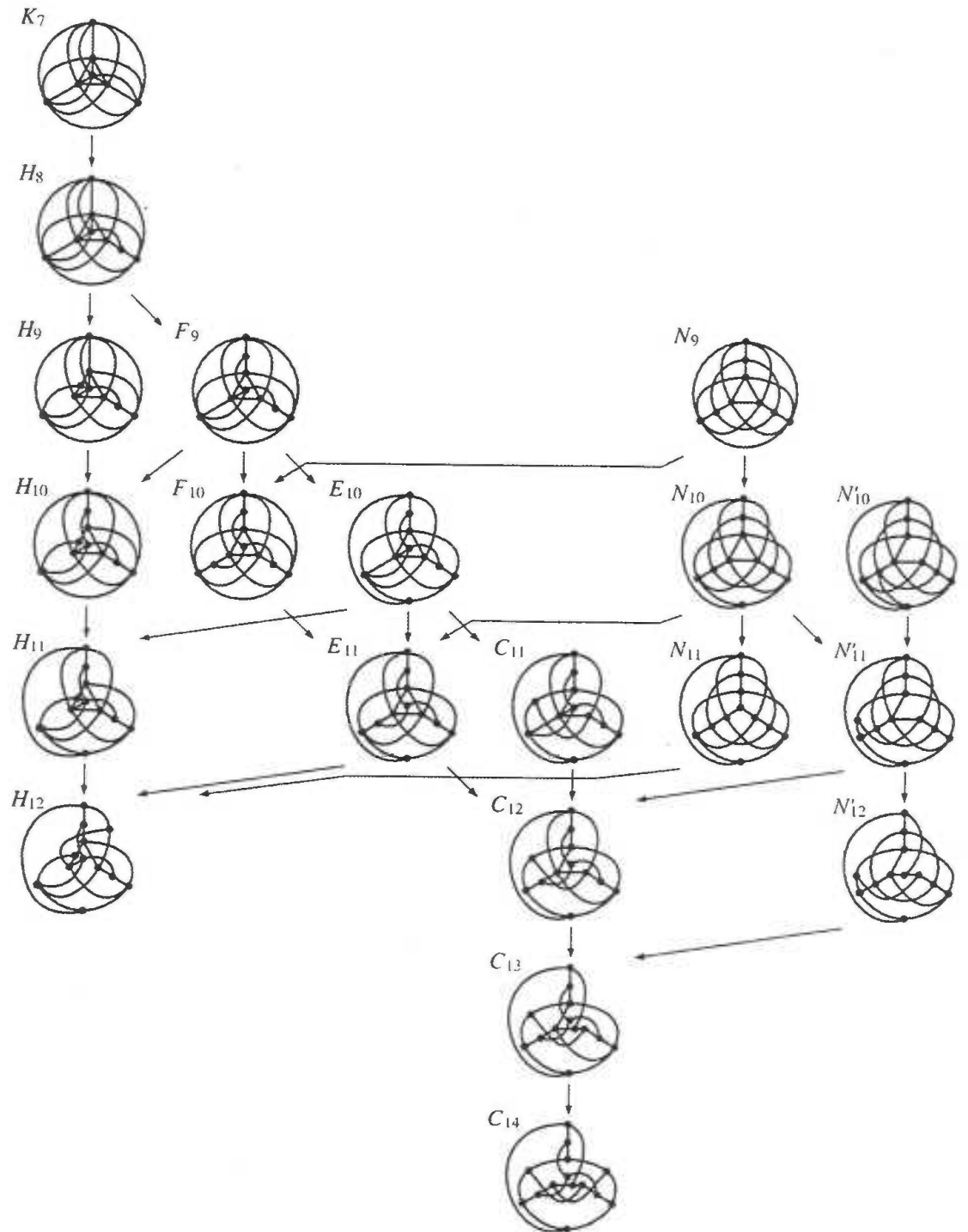

Figure 6.3: The Heawood family as it appeared in (8). Each arrow refers to  $\Delta - Y$  exchange.

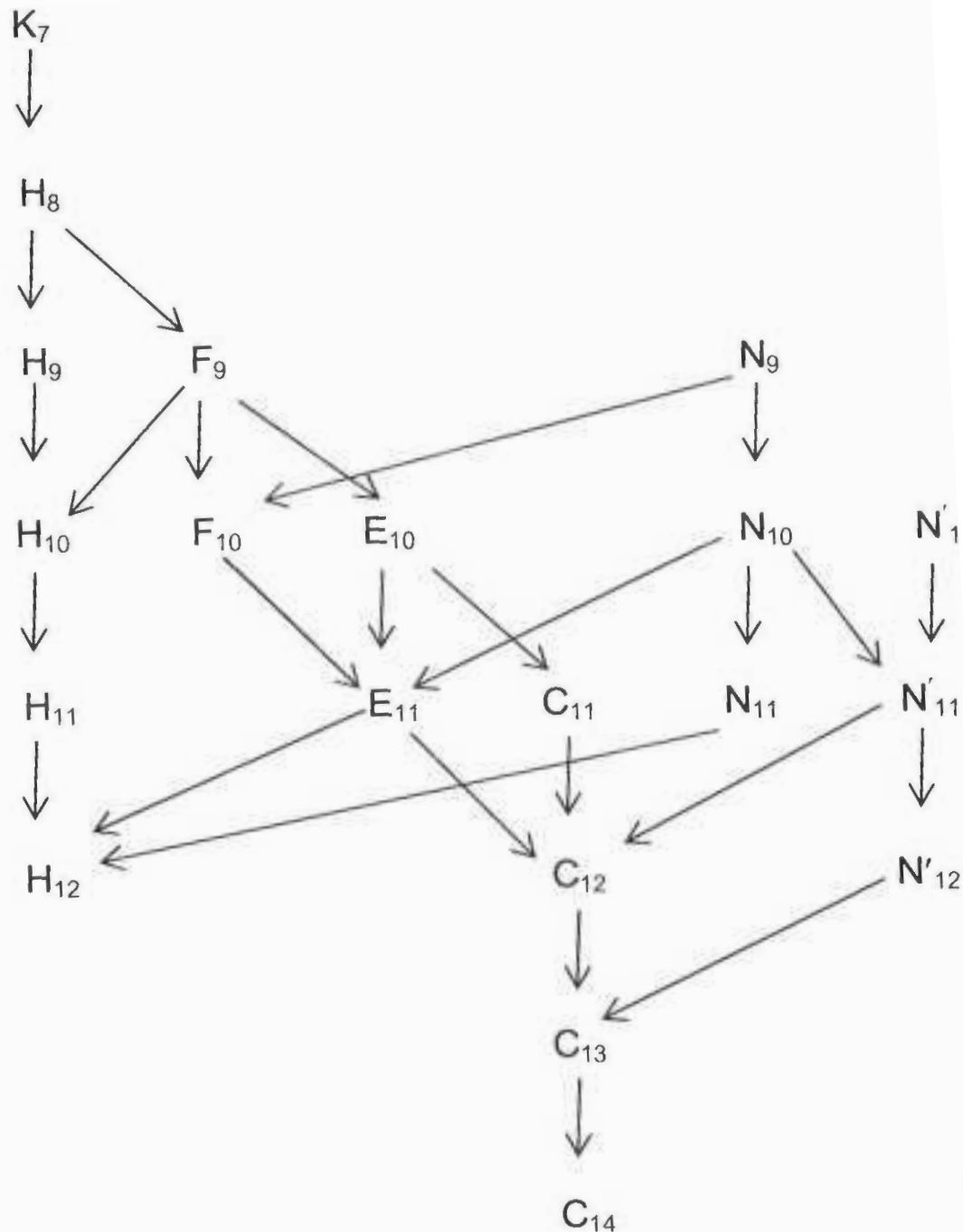

Figure 6.4: The Heawood family scheme.

## 6.1 Intrinsically linked and intrinsically knotted graphs

### 6.1.1 The Petersen family

There are many studies which deal with the Petersen family. Almost all of these studies are focused on the important property that each member is intrinsically linked (IL) which

is defined in Chapter 1. A graph  $G$  is called **intrinsically linked** (IL) if in any embedding of  $G$  in  $\mathbb{R}^3$  there is a pair of disjoint cycles  $C_1$  and  $C_2$  with  $lk(C_1, C_2) \neq 0$ .

We state below the key results.

**Theorem 43**  $K_6$  is IL.

**Proof**

See (5)

□

By using the same method as in the proof of Theorem 43, the following theorem can be proved. The graph  $\mathbf{K}_{3,3,1}$  is defined as follows. Its vertex set is the disjoint union of three subsets  $V_1, V_2$  and  $V_3$ .  $V_1$  contains one vertex, while  $V_2$  and  $V_3$  each contain three vertices. The two endpoints of every edge in  $G$  lie in different subsets, and every pair of vertices taken from different subsets have an edge joining them.

**Theorem 44**  $K_{3,3,1}$  is IL.

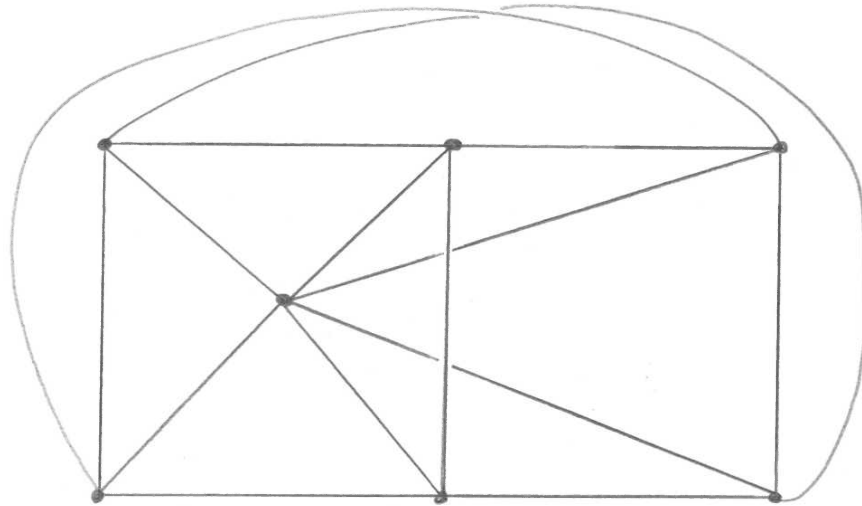

Figure 6.5:  $K_{3,3,1}$ .

**Proof**

Let  $\lambda = \sum lk(C_1, C_2)$  so that  $\lambda \in \mathbb{Z}_2$ .

There are infinitely many ways of embedding  $K_{3,3,1}$  in  $\mathbb{R}^3$ . These are all obtained from each other by crossing changes on a plane diagram of the embedding. We need to discover what happens to  $\lambda$  when a crossing change is made.

There are 9 different pairs of disjoint cycles in  $K_{3,3,1}$ .

Firstly, let the crossing be of an edge with itself as in figure 6.6. This means that for any pair of disjoint cycles  $(C_1, C_2)$ ,  $lk(C_1, C_2)$  remains unchanged when we change this crossing, and this leads to  $\lambda$  being unchanged.

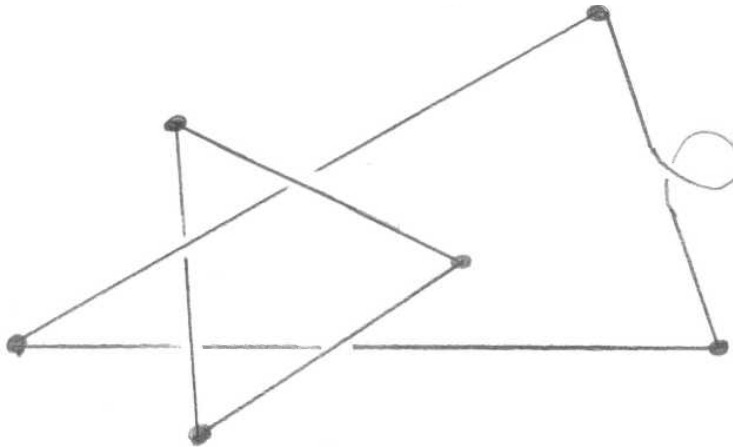

Figure 6.6: The edge crossing itself.

Secondly, if the crossing is of adjacent edges, as in figure 6.7, this means again that for any pair of disjoint cycles  $\{C_1, C_2\}$ ,  $lk(C_1, C_2)$  remains unchanged when we change this crossing, and this leads to  $\lambda$  being unchanged.

Thirdly, consider a crossing of nonadjacent edges. There are two cases: in the first case, these two edges are in the same cycle, as in figure 6.8. This means yet again that for any pair of disjoint cycles  $\{C_1, C_2\}$ ,  $lk(C_1, C_2)$  is unchanged, which leads to  $\lambda$  being unchanged.

In the second case, let the edges of this crossing be in two disjoint cycles, as in figure 6.9. Now we show that for the specific embedding of  $K_{3,3,1}$  shown in figure 6.5,  $\lambda = 1$ . We see a crossing of the edges and two pairs of distinct cycles containing this crossing.

The linking number of just one of these two pairs is equal to one and all other linking numbers of disjoint cycles in this graph are equal to zero. Hence  $\lambda = 1$ .

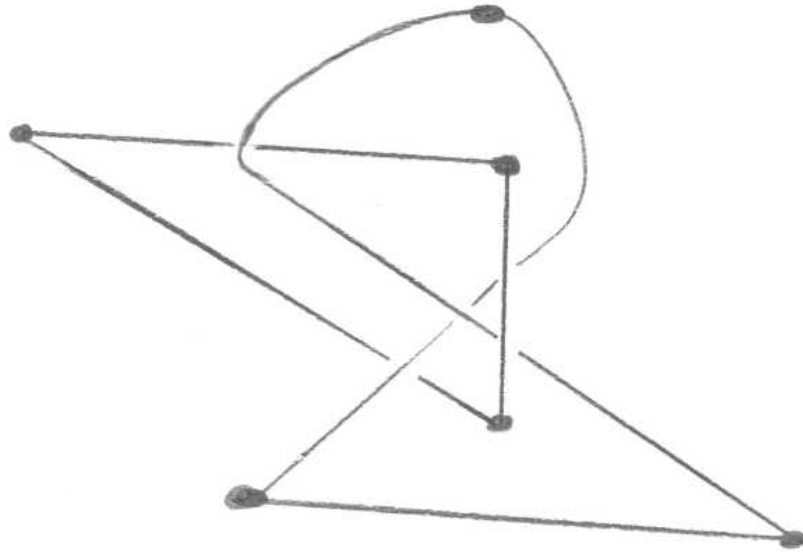

Figure 6.7: The adjacent edges are crossing.

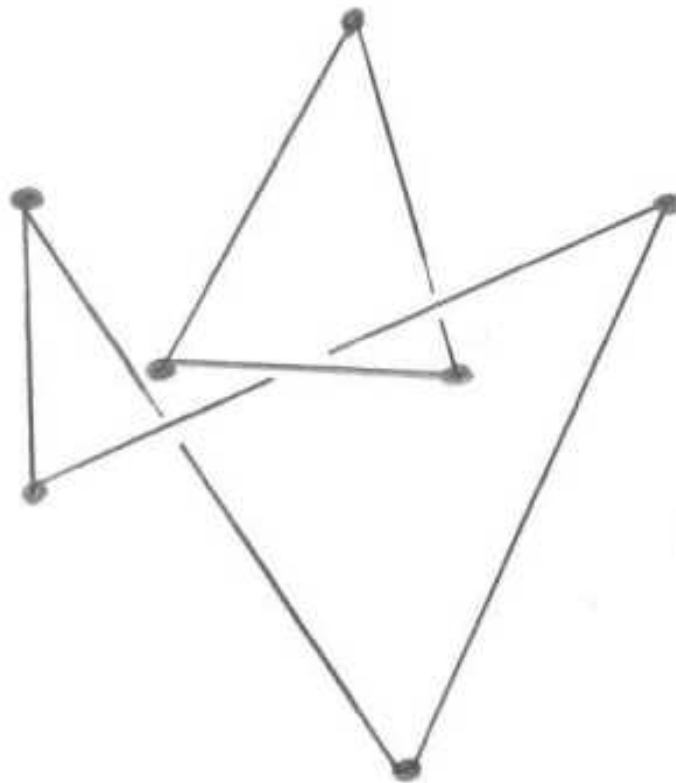

Figure 6.8: The crossing of non adjacent edges in one cycle.

Let the pair with linking number be  $(C_1, C_2)$ , the first edge be  $A_1 \in C_1$ , and the second edge be  $A_2 \in C_2$ . We can always find another pair of distinct cycles  $(C_3, C_4)$  such

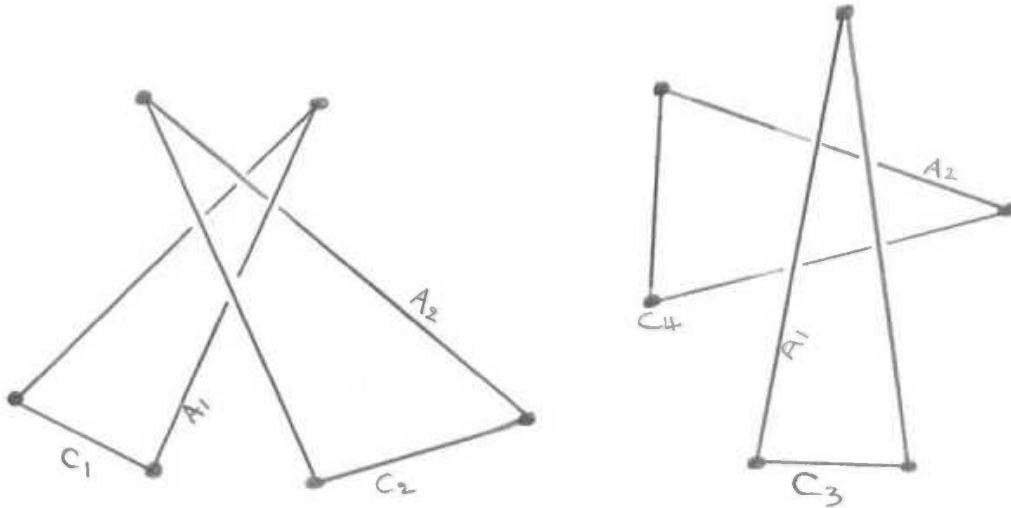

Figure 6.9: The crossing of non adjacent edges in two cycles.

that  $A_1 \in C_3$  and  $A_2 \in C_4$ . It can be noted that if  $lk(C_1, C_2) = 1$  then  $lk(C_3, C_4) = 0$ . When changing this crossing, we get  $lk(C_1, C_2) = 0$ , and  $lk(C_3, C_4) = 1$ ; therefore  $\lambda$  is unchanged.

□

Theorem (45) below is proved in (19). Here, we give a slightly modified version. We need before introduce the following definition. If  $K_1$  and  $K_2$  are two knots,

$$H : \mathbb{R}^3 \times [0, 1] \longrightarrow \mathbb{R}^3,$$

is a continuous function where  $H(x, 0) = K_1$  and  $H(x, 1) = K_2$ ,  $x \in \mathbb{R}^3$ , then  $K_1$  and  $K_2$  are **ambient isotopy**.

**Theorem 45** *If  $G$  is IL, and  $G'$  is a graph obtained from  $G$  by abstract  $\Delta \rightarrow Y$  exchanges then  $G'$  is IL.*

### Proof

Suppose that  $H'$  is a linkless embedded graph of  $G'$ . We use this embedding to construct an embedded graph of  $G$ , denoted  $H$ , which is linkless. This would be a contradiction.



Let  $(u,x)$ ,  $(v,x)$  and  $(w,x)$  be the edges in  $H'$  as in figure 6.10 (A). By changing these edges to double edges as in figure 6.10 (B), then deleting  $x$  and joining these edges as in figure 6.10 (C), we then obtain the triangle  $uvw$  and construct  $H$ . This operation does not change the linking structure of  $H'$  by ambient isotopy.

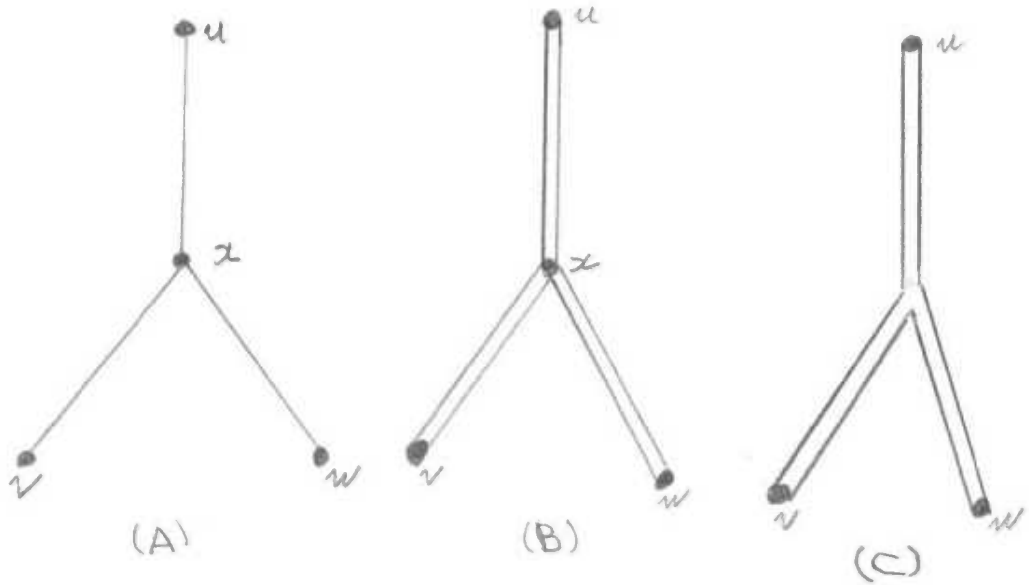

Figure 6.10: (A) is a  $Y$  in  $H'$ , (B) replaces each edge in (A) by a double edge, and (C) removes the vertex  $x$  in (B) to get a triangle.

Since  $H'$  is a linkless embedding of  $G'$  then the triangle  $uvw$  can not be linked with any other cycle in  $H$ . Let  $C_1$  and  $C_2$  be two linked cycles in  $H$ , and suppose  $C_1$  uses the edges of this triangle, but not as a cycle. Assume  $C_1$  enters into the triangle at  $v$  and leaves it at  $w$ . This can be done in two ways:  $C_1$  can use the edge  $(v,w)$  or the other two edges  $(v,u)$  and  $(u,w)$ . There is the same cycle in  $H'$  as  $C_1$  and this cycle is denoted  $C'_1$  but uses the edges  $(v,x)$  and  $(x,w)$ .

This gives us the relationship between  $C'_1$  and  $C_2$  in  $H'$  which is the same as one existing between  $C_1$  and  $C_2$  in  $H$ . This is a contradiction.  $\square$

From Theorems 43, 44 and 45 we obtain the following.

**Theorem 46** *All the graphs in  $\mathcal{P}$  are IL.*

**Proof**

The Petersen family has seven different graphs. The first is  $K_6$ , which is *IL* by Theorem 43. Another member of the Petersen family is  $K_{3,3,1}$ , and this graph is *IL* by Theorem 44. The remaining five graphs in the Petersen family were obtained from  $K_6$  by  $\Delta \rightarrow Y$  exchange, and this means that these graphs are *IL* by Theorem 45.  $\square$

### 6.1.2 The Heawood family

Almost all of the research into  $\mathcal{H}$  studies the intrinsically knotted (*IK*) features of some members in this family. (*IK*) is defined in Chapter 1.

**Theorem 47**  $K_7$  is *IK*.

**Proof**

See (5).  $\square$

**Theorem 48** If  $G$  is *IK* and  $G'$  is a graph obtained from  $G$  by  $\Delta \rightarrow Y$  exchanges, then  $G'$  is *IK*.

**Proof** See (19).  $\square$

But if  $G'$  is obtained from  $G$  by  $Y \rightarrow \Delta$  exchanges, then  $G'$  is not always *IK*. Graph  $N_{11}$  is one example of this case.

## 6.2 The number of components of a link diagram in the Petersen and Heawood families

Embedded  $Y \leftrightarrow \Delta$  exchanges do not alter the value of  $\mu$ , as we saw in Theorem 6. But if we restrict to embedded  $Y \leftrightarrow \Delta$  exchanges then we may not get the same families of graphs, of course. So in this section we explore this question by studying particular embeddings of  $K_6$  and  $K_7$ .

### 6.2.1 Embedded Petersen families

We know that all of the (abstract) graphs  $\mathcal{P}$  can be cellularly embedded in the torus. These embeddings are not unique, however. Therefore, we have different values of  $\mu$  depending

on the embedding. We start with  $K_6$ , and we restrict to the embedded of  $Y \leftrightarrow \Delta$  exchanges. Choosing particular embeddings of  $K_6$  give us subfamilies of  $\mathcal{P}$  whose members all have the same value of  $\mu$ .

The summary of preliminary results can be found in the table below, where we use the graph names given in (8). We prove these results in the theorems following.

the choice of embedding	$\mu$	the family obtained using embedded $Y \leftrightarrow \Delta$ exchanges
(a)	3	$\mathcal{P}$
(b)	3	$\mathcal{P} \setminus \{Q_8\}$
(c)	3	$\mathcal{P} \setminus \{P_{10}, Q_8\}$
(d)	5	$\mathcal{P} \setminus \{P_{10}, Q_8\}$
(e)	5	$\mathcal{P} \setminus \{P_{10}\}$
(f)	7	$\mathcal{P} \setminus \{P_{10}\}$

In the following theorem we obtain three subfamilies of  $\mathcal{P}$  from the embedded  $\Delta \leftrightarrow Y$  exchanges, where  $\mu = 3$ .

**Theorem 49** *Consider the embedding of  $K_6$  given in figure 6.11. The embedded  $\Delta \leftrightarrow Y$  exchanges on this embedding give rise to the following three subfamilies of  $\mathcal{P}$ :*

1.  $\mathcal{P}$ .
2.  $\mathcal{P} \setminus \{Q_8\}$ .
3.  $\mathcal{P} \setminus \{P_{10}, Q_8\}$ .

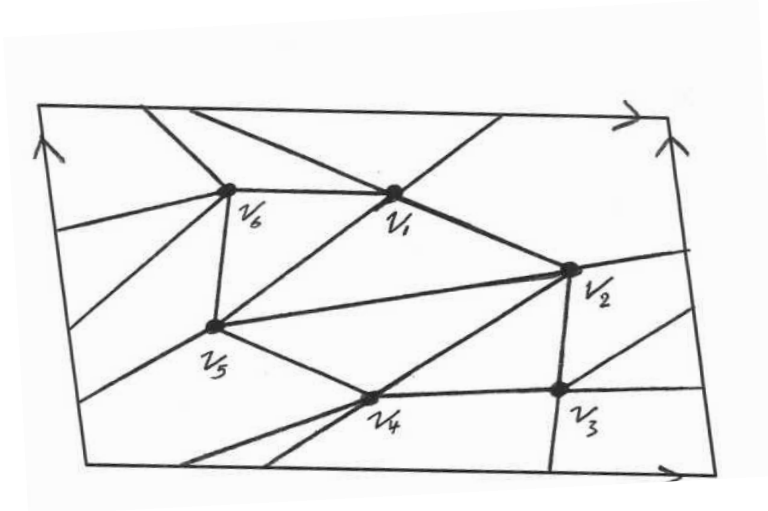

Figure 6.11: One embedding of  $K_6$  in the torus.

### Proof

Figure 6.11 of the embedding of  $K_6$  contains eight triangles, each bounding a disc. There is a disjoint pair of these triangles,  $\{v_1, v_5, v_6\}$  and  $\{v_2, v_3, v_4\}$ . Suppose triangle  $\{v_1, v_5, v_6\}$  is chosen to be changed to  $Y_{x_1}$  (where  $x_1$  is the new vertex added to the graph) to get the embedding of  $Q_7$  shown in figure 6.12.

This embedding of  $Q_7$  has four triangles. One of these is  $\{v_2, v_3, v_4\}$ , and when it is changed to a  $Y$  the embedding of  $Q_8$  is obtained as shown in figure 6.12.

Now we have three members of  $\mathcal{P}$ . If we choose any one of the three remaining triangles in  $Q_7$  to change to a  $Y_{x_3}$ , we get an embedding of  $P_8$ . Suppose the triangle chosen is  $\{v_4, v_2, v_5\}$ , as in figure 6.12.

The embedding of  $P_8$  has three vertices of degree three, one of these vertices being  $v_5$ . Let  $Y_{v_5}$  be changed to the triangle  $\{v_3, x_1, x_3\}$ , which yields the embedding of  $K_{3,3,1}$  as in figure 6.12, to increase the number of members  $\mathcal{P}$  to five.

Now, if triangle  $\{v_3, v_2, v_6\}$  is changed to  $Y_{x_4}$ , then the embedding of  $P_9$  is obtained, as in figure 6.12.

The embedding of  $P_9$  has one triangle and when this is changed to  $Y_{x_5}$  the embedding of the Petersen graph is acquired, as in figure 6.12.

So our subfamily is in fact  $\mathcal{P}$ .

Return to the embedding of  $K_6$  and choose any other triangle which is not one of the

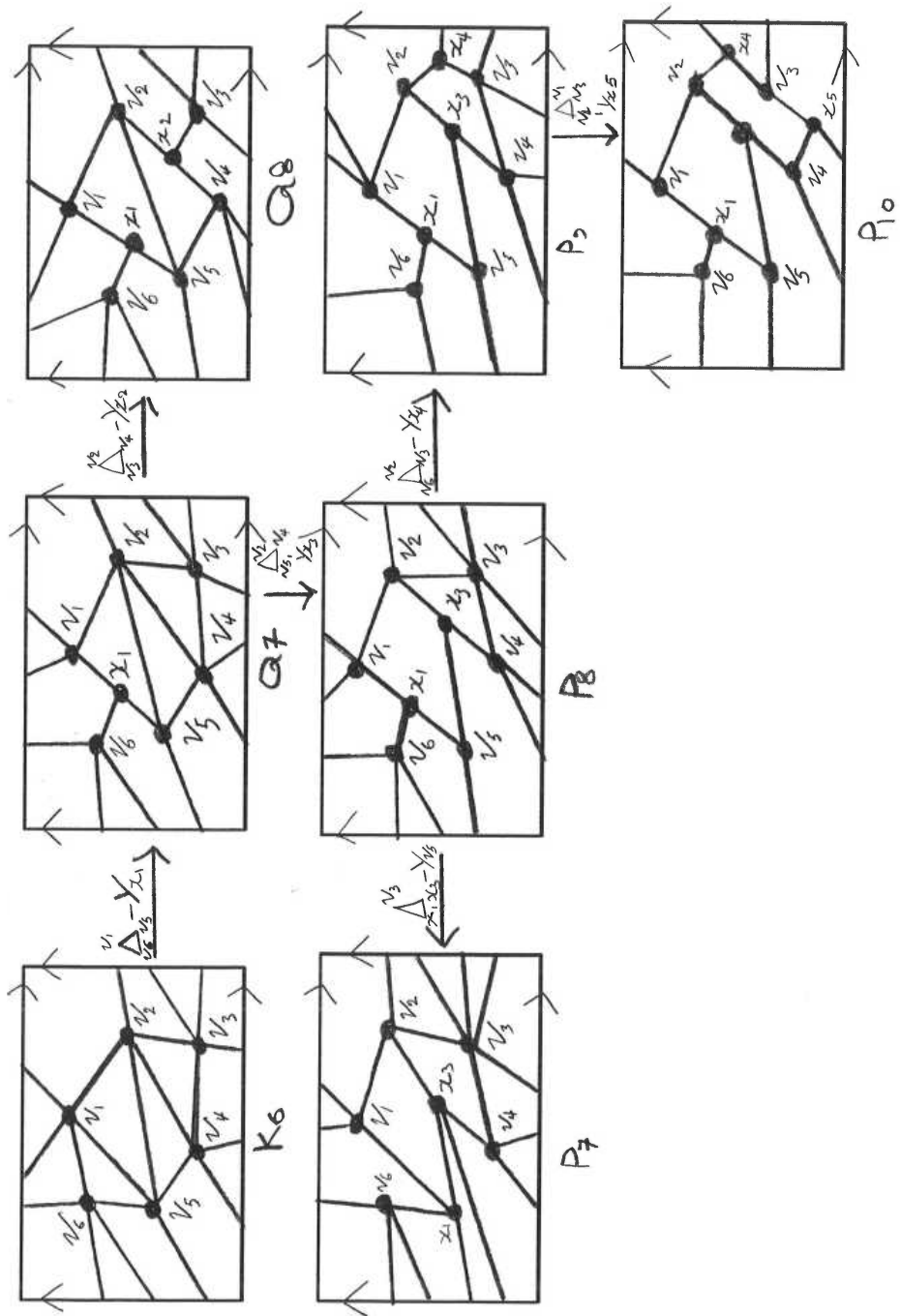

Figure 6.12: The embedding of a Petersen subfamily in the torus.

pair of the disjoint triangles  $\{v_1, v_5, v_6\}$  and  $\{v_2, v_3, v_4\}$ . Let this triangle be  $\{v_2, v_5, v_4\}$ . Then we get the embedding of  $Q_7$  when this triangle is changed to  $Y$ , as in figure 6.13.

To get the embedding of  $Q_8$  we would need triangle  $\{v_1, v_3, v_6\}$ , but this does not bound a disc. So far we have two members of  $\mathcal{P}$ . The embedding of  $Q_7$  has five triangles bounding a disc. If we choose any one of the following triangles  $\{v_1, v_5, v_6\}, \{v_2, v_3, v_6\}$ ,

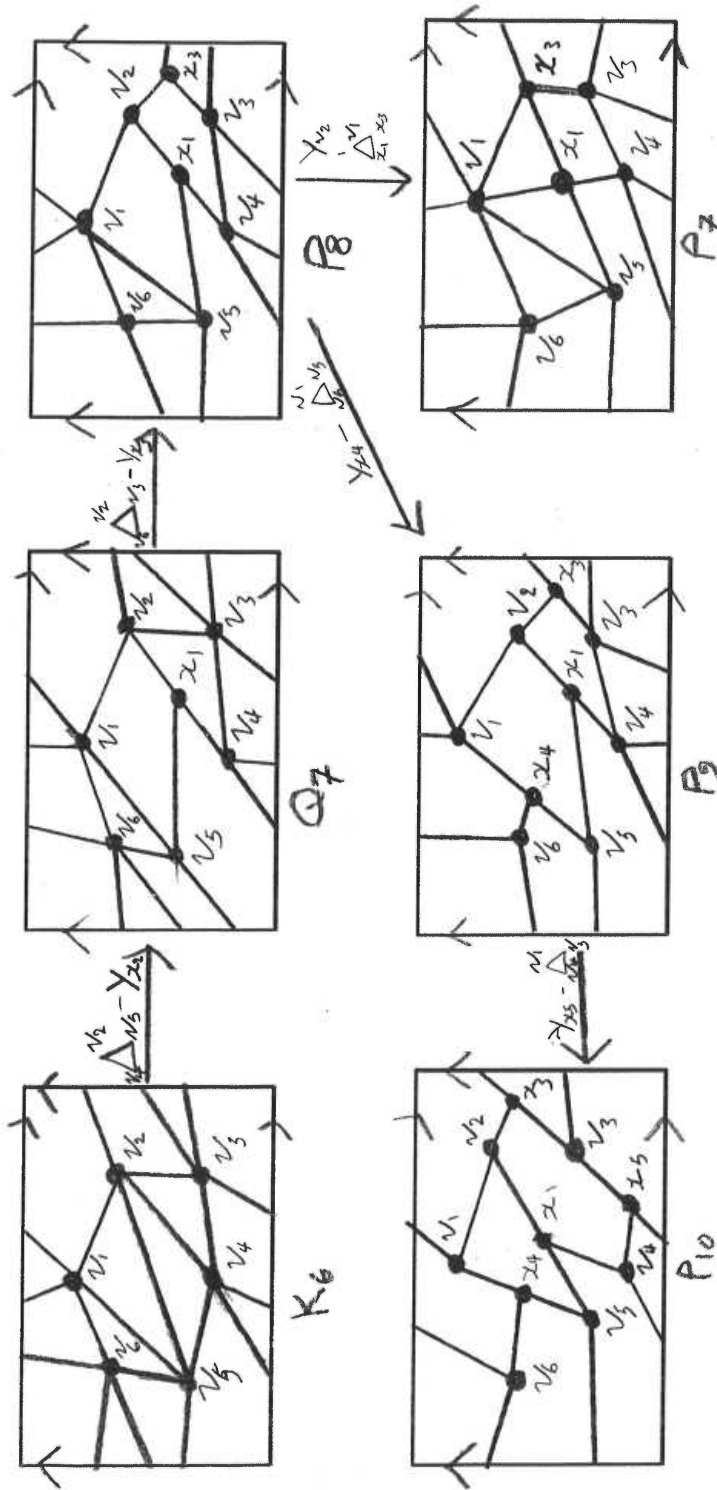

Figure 6.13: The embedding of a Petersen subfamily in the torus.

or  $\{v_1, v_3, v_4\}$  we obtain members of the subfamily  $\mathcal{P} \setminus \{Q_8\}$  as in figure 6.13.

Now, let us return to the final embedding of  $Q_7$  in figure 6.13 and choose either triangle  $\{v_1, v_4, v_6\}$  or  $\{v_5, v_3, v_6\}$ . We get an embedding of  $P_8$ . Then from this we can obtain the

embeddings of  $P_7$  and  $P_9$ , but  $P_{10}$  needs triangle  $\{v_1, v_2, v_3\}$ , which is impossible, as shown in figure 6.14.

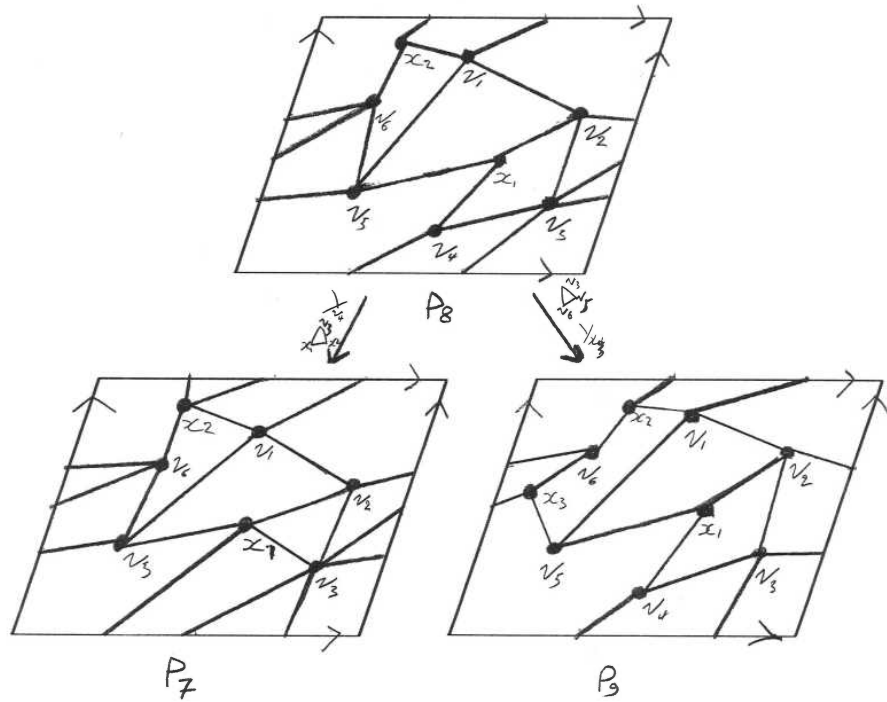

Figure 6.14: The embeddings of three members of Petersen subfamily in the torus.

Hence we have the third subfamily in the statement of the theorem. □

The following theorem is for another embedding of  $K_6$  having  $\mu = 3$ , different from the

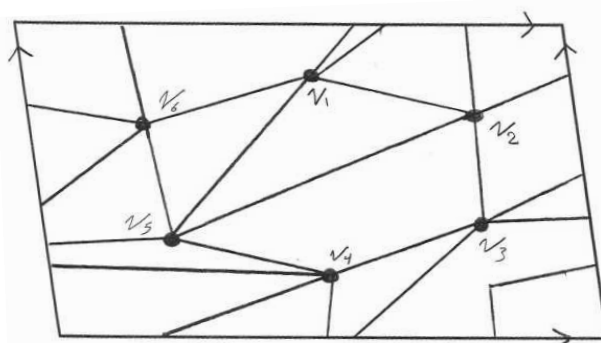

Figure 6.15: An embedding of  $K_6$  in the torus.

embedding of the previous theorem. It gives rise to two subfamilies of  $\mathcal{P}$ .

**Theorem 50** Consider the embedding of  $K_6$  given in figure 6.15. The embedded  $\Delta \leftrightarrow Y$  exchanges on this embedding give rise to the following  $\mathcal{P}$ :

1.  $\mathcal{P} \setminus \{Q_8, P_{10}\}$ .

2.  $\mathcal{P} \setminus \{Q_8\}$ .

**Proof**

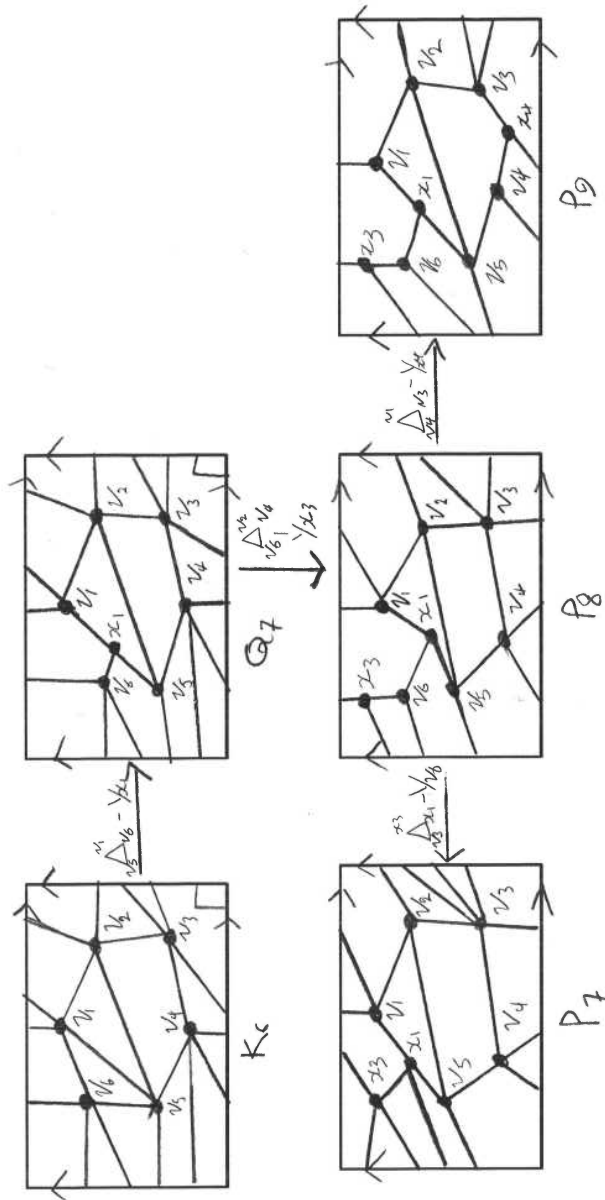

Figure 6.16: The embeddings of a Petersen subfamily in the torus.

The embedding of  $K_6$  in figure 6.15 has seven triangles each bounding a disc. These seven triangles do not include a pair of disjoint triangles. Therefore, an embedding of  $Q_8$  cannot be reached by embedded  $\Delta \leftrightarrow Y$  exchanges.



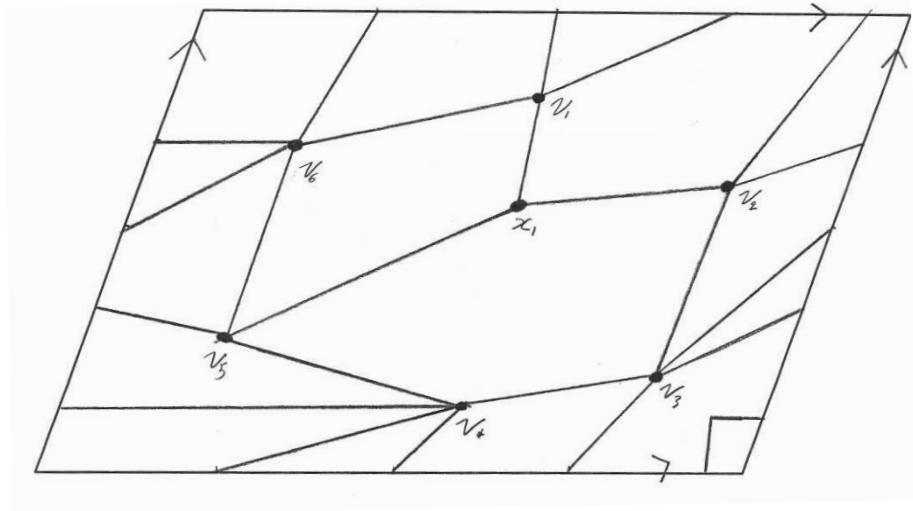

Figure 6.17: An embedding of  $Q_7$  in the torus.

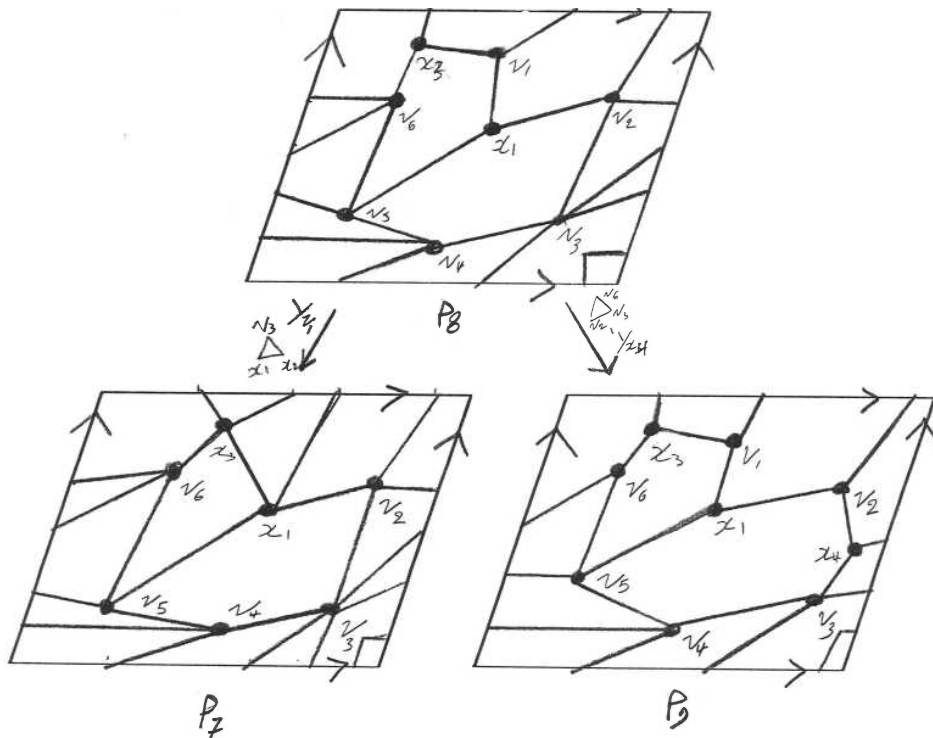

Figure 6.18: The embedding of some members of a Petersen subfamily in the torus.

We now choose one of these seven triangles. Suppose triangle  $\{v_1, v_6, v_5\}$  is chosen, where each edge in this triangle is an edge of another triangle. In this case we obtain the embedding of  $Q_7$  with three triangles, as in figure 6.16. Two of these three triangles share an edge, they are  $\{v_2, v_3, v_6\}$  and  $\{v_2, v_4, v_6\}$ . If one of these two triangles is changed to  $Y$  we get the embedding of  $P_8$  which will contain just one triangle bounding a disc, as

in figure 6.16. This triangle is  $\{v_1, v_3, v_4\}$ , and when it is changed to  $Y$  we get  $P_9$ , as in figure 6.16.  $P_{10}$  is impossible because it needs triangle  $\{v_2, v_3, v_5\}$  which does not bound a disc. We can get the embedding of  $P_7$  from the embedding of  $P_8$ , and hence obtain the subfamily  $\mathcal{P} \setminus \{Q_8, P_{10}\}$ .

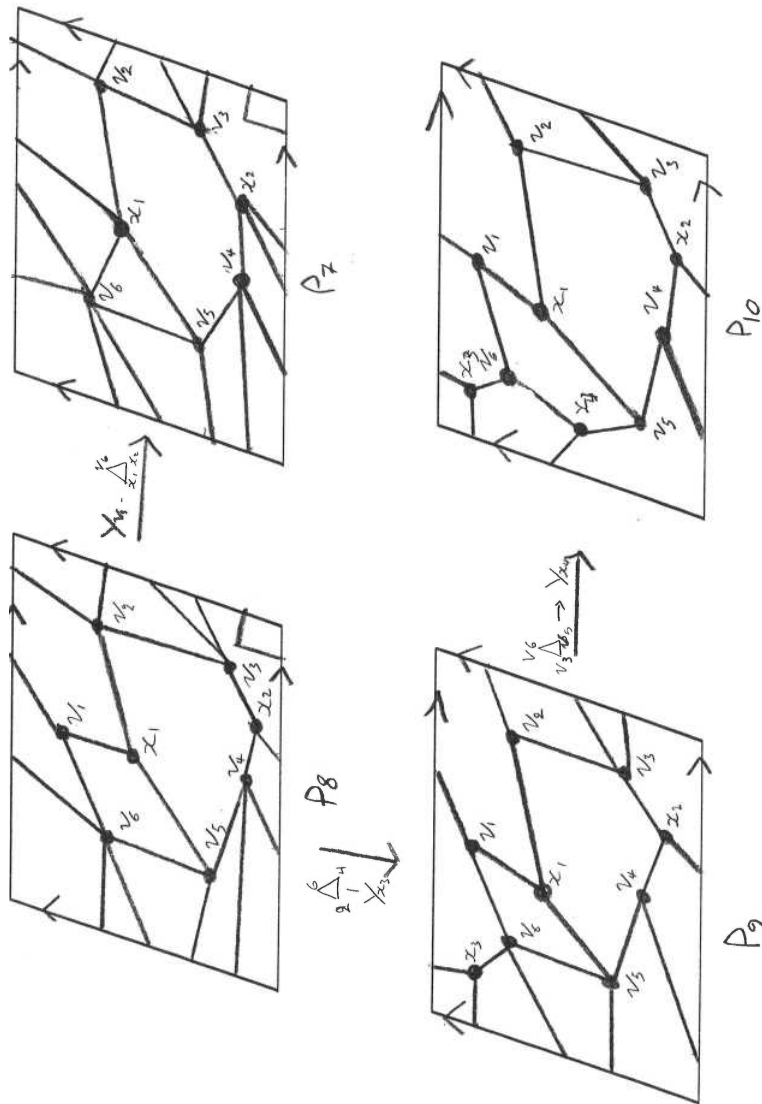

Figure 6.19: The embedding of some members of a Petersen subfamily in the torus.

The same result can be obtained by choosing triangle  $\{v_1, v_6, v_4\}$  or  $\{v_1, v_3, v_4\}$  in the embedding of  $K_6$ . However, if we choose triangle  $\{v_1, v_2, v_5\}$  from the embedding of  $K_6$ , where this triangle has a common edge with triangle  $\{v_1, v_6, v_5\}$ , we get the embedding

of  $Q_7$  having five triangles, as in figure 6.17.

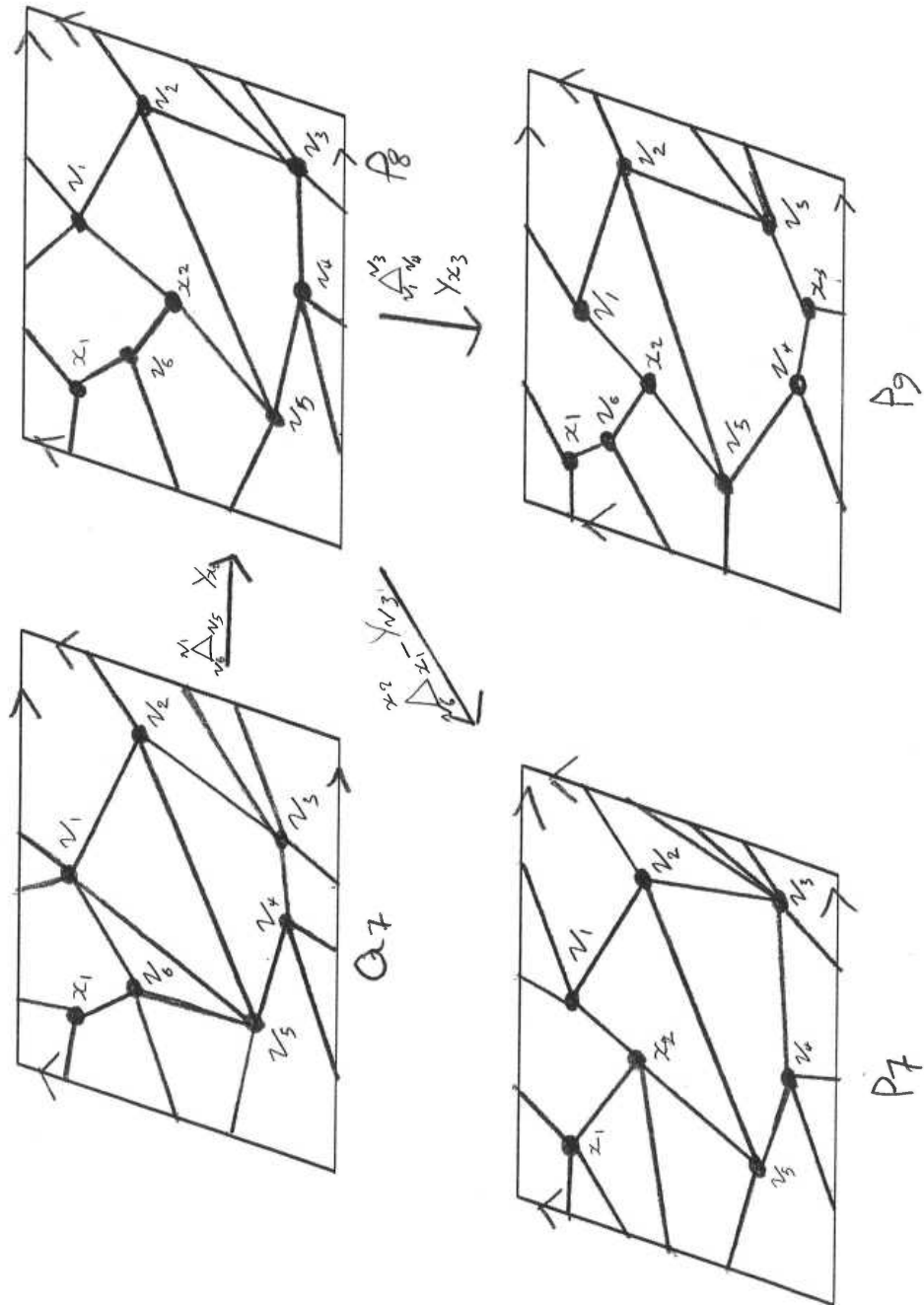

Figure 6.20: The embedding of some members of a Petersen subfamily in the torus.

This embedding of  $Q_7$  can give two subfamilies. The first is  $\mathcal{P} \setminus \{Q_8, P_{10}\}$ , when we choose either  $\{v_1, v_4, v_6\}$  or  $\{v_2, v_3, v_6\}$ , as in figure 6.18.

The second subfamily is  $\mathcal{P} \setminus \{Q_8\}$ , when we choose one of the following triangles  $\{v_1, v_3, v_4\}$ ,  $\{v_3, v_5, v_6\}$ , or  $\{v_2, v_4, v_6\}$ , as in figure 6.19.

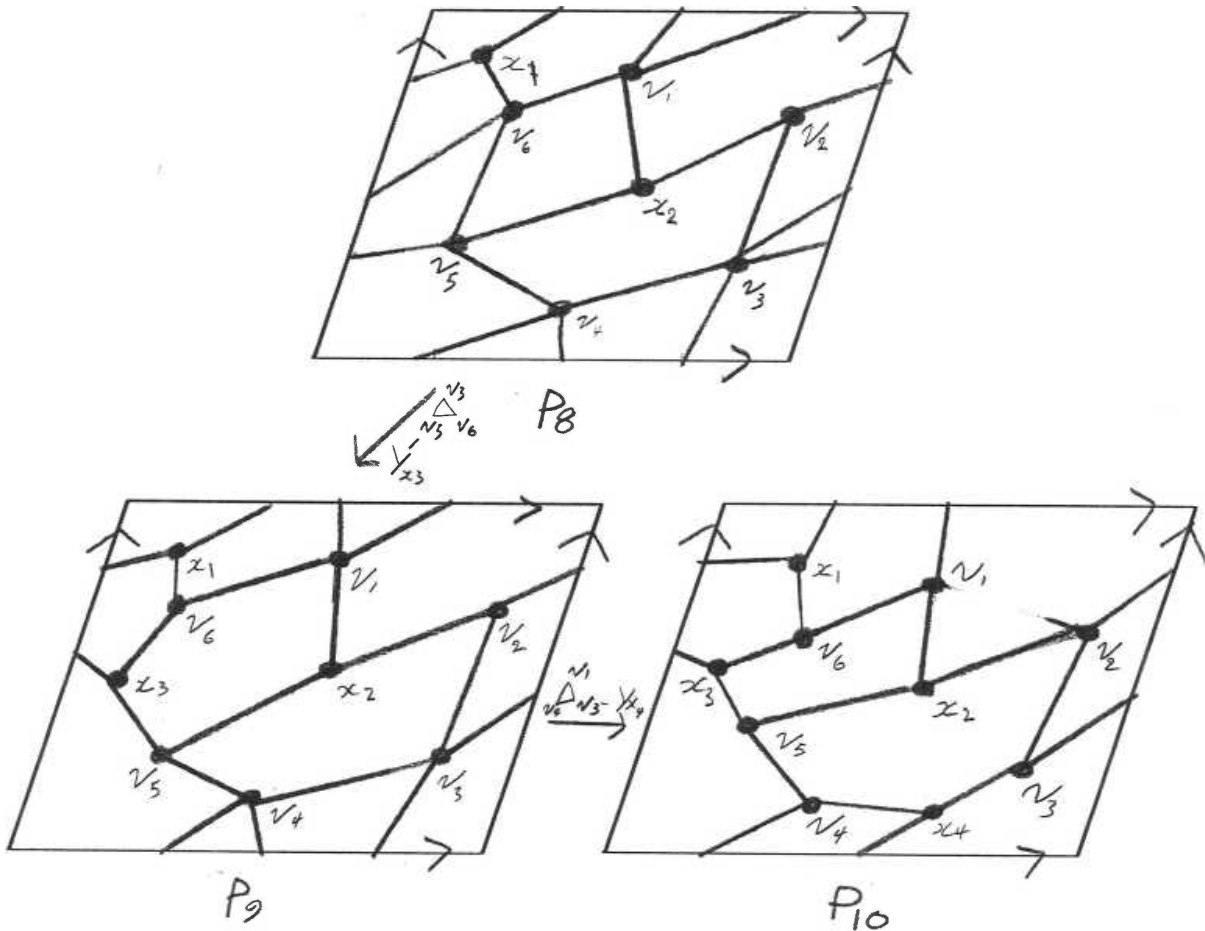

Figure 6.21: The embedding of some members of a Petersen subfamily in the torus.

Each of the remaining three triangles of the embedding of  $K_6$  has two common edges with two different triangles. If any one of these three triangles is changed to a  $Y$ , as in figure 6.20, then the embedding of  $Q_7$  has four triangle, one of which has a property where it shares two edges with other triangles. If it is changed we obtain the embedding of  $P_8$  having one triangle which means that the embedding of  $P_9$  is possible. It is easy to get the embedding of  $P_7$  from the embedding of the last  $P_8$ , and hence the family  $\mathcal{P} \setminus \{Q_8, P_{10}\}$  is achieved. But when we choose another triangle of the embedding of  $Q_7$  in figure 6.20 we obtain the subfamily  $\mathcal{P} \setminus \{Q_8\}$ , as in figure 6.21. □

The following theorem is for another embedding of  $K_6$ , which has  $\mu = 5$ . It gives a

different collection of Petersen subfamilies.

**Theorem 51** Consider the embedding of  $K_6$  given in figure 6.22. The embedded  $\Delta \leftrightarrow Y$  exchanges on this embedding give rise to the two following subfamilies of  $\mathcal{P}$ :

1.  $\mathcal{P} \setminus \{P_{10}\}$ .
2.  $\mathcal{P} \setminus \{Q_8, P_{10}\}$ .

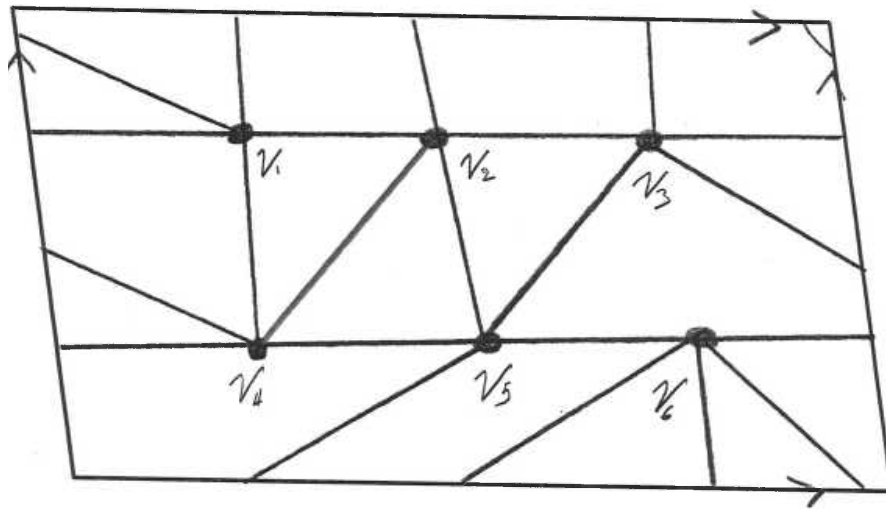

Figure 6.22: An embedding of  $K_6$  in the torus.

### Proof

The embedding of  $K_6$  in figure 6.22 has a pair of disjoint triangles bounding a disc, which are  $\{v_1, v_3, v_6\}, \{v_2, v_4, v_5\}$ . If a change is made to one of these triangles, we obtain  $Q_8$ . Suppose triangle  $\{v_1, v_3, v_6\}$  in  $K_6$  is changed to  $Y$ , then the embedding of  $Q_7$  is obtained as in figure 6.23. This embedding has three triangles bounding a disc.

One of these triangles is  $\{v_2, v_4, v_5\}$ , having two common edges with the other triangles. Changing this triangle gives  $Q_8$  as in figure 6.23. Let us return to  $Q_7$ , choosing any other triangle and changing it to  $Y$ . The embedding of  $P_8$  is acquired and it contains one triangle. If this triangle is changed to  $Y$ , we get the embedding of  $P_9$ , but in this case the embedding of  $P_{10}$  is impossible as in figure 6.23.

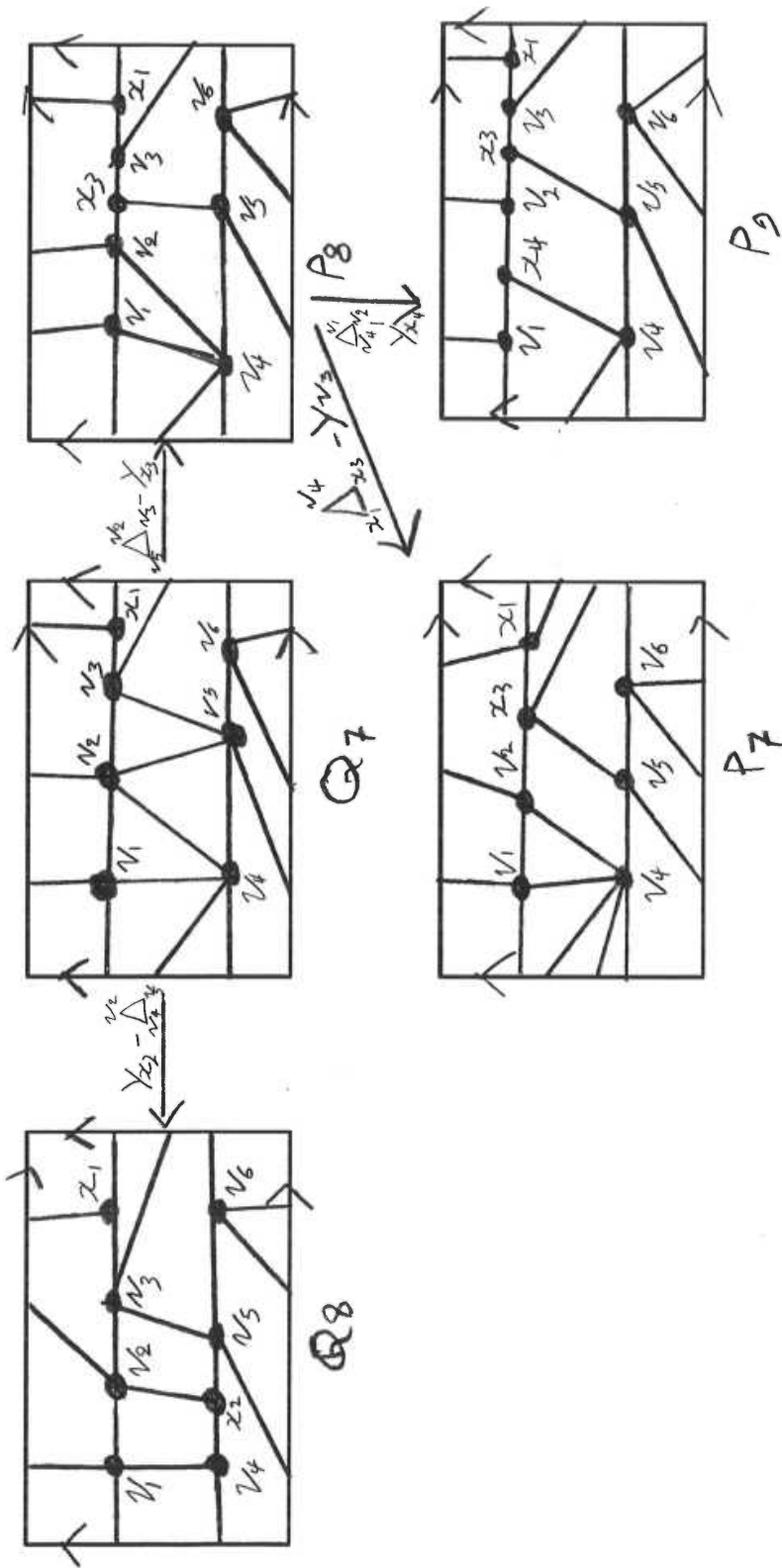

Figure 6.23: Embeddings of some members of Petersen subfamily in the torus.

To get  $P_{10}$  we need triangle  $\{v_4, v_5, v_6\}$  in  $P_9$ , which does not bound a disc. The embedding of  $P_7$  is clear. Hence we obtain the subfamily  $\mathcal{P} \setminus \{P_{10}\}$ . The same subfamily can be obtained by making changes to triangle  $\{v_2, v_4, v_5\}$ .

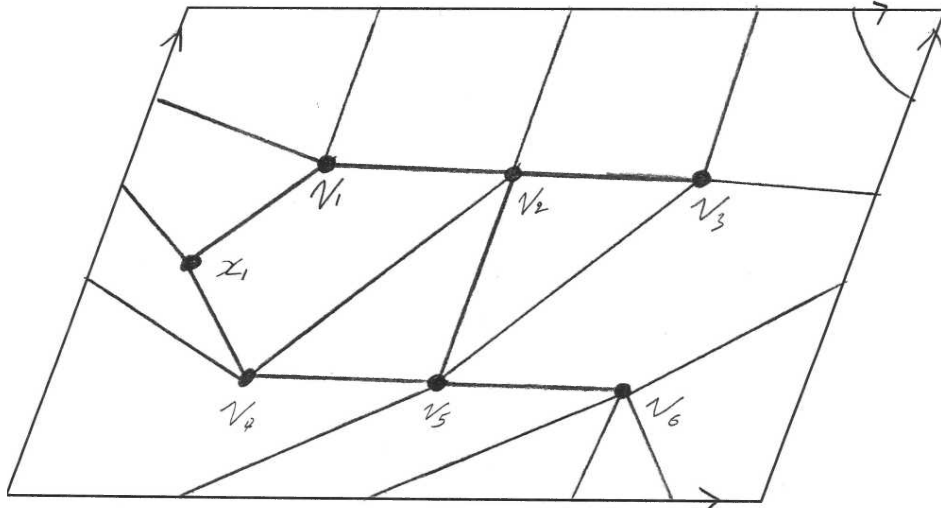

Figure 6.24: An embedding of  $Q_7$  in the torus.

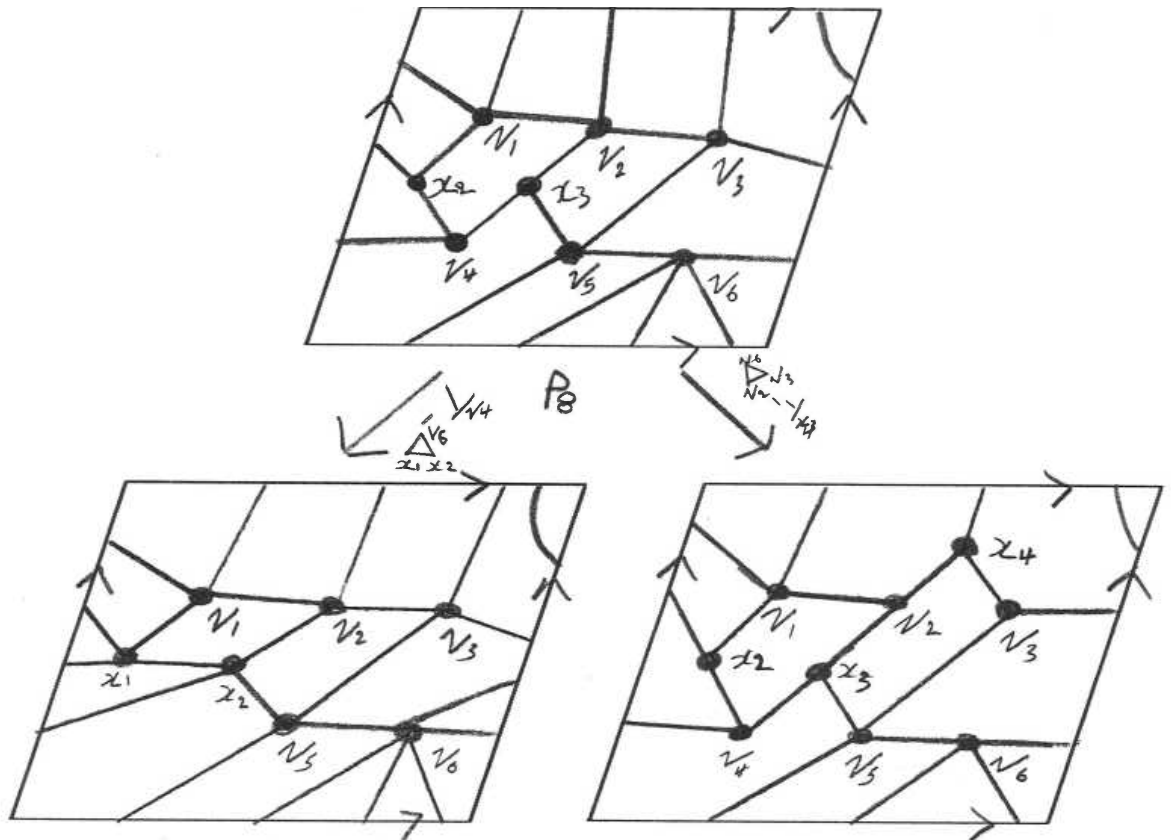

Figure 6.25: Embeddings of some members of Petersen subfamily in the torus.

To achieve the subfamily  $\mathcal{P} \setminus \{Q_8, P_{10}\}$  we need to start by choosing another triangle, which is not one of the pair of disjoint triangles. Let triangle  $\{v_1, v_3, v_4\}$  be chosen. When it is changed to  $Y$ , the embedding of  $Q_7$  is obtained as in figure 6.24. This embedding has three triangles. Changing any of these gives  $P_8$ , which has one triangle, as in figure 6.25. This means  $P_9$  and  $P_7$  are achievable, but  $P_{10}$  is not.  $\square$

In the next theorem we have an embedding of  $K_6$  having  $\mu(D(G)) = 7$  and six triangles. Each triangle belongs to a pair of disjoint triangles, which means this embedding has three pairs of disjoint triangles.

**Theorem 52** *Consider the embedding of  $K_6$  given in figure 6.26. The embedded  $\Delta \leftrightarrow Y$  exchanges on this embedding give rise to the subfamily  $\mathcal{P} \setminus \{P_{10}\}$ .*

**Proof**

This embedding of  $K_6$  has six triangles, each bounding a disc. The properties of these triangles are as follows: They are three pairs of disjoint triangles and each triangle has two common edges with two other triangles. Therefore, changes made to any triangle will give the same family. Suppose we are starting with triangle  $\{v_1, v_2, v_4\}$ , where the other triangle in this pair is  $\{v_3, v_5, v_6\}$ . An embedding of  $Q_7$  is obtained and it contains three triangles. One of these three triangles is  $\{v_3, v_5, v_6\}$ , and when this is changed to  $Y$ , we will obtain an embedding of  $Q_8$ . If we choose any other of the two remaining triangles in  $Q_7$ , we get the same result. Where the embedding of  $P_8$  has one triangle the embeddings of  $P_9$  and  $P_7$  are possible. To obtain the embedding of  $P_{10}$  in this subfamily we need triangle  $\{v_4, v_5, v_6\}$  in the embedding of  $P_9$ , but this triangle does not bound a disc which make the embedding of  $P_{10}$  is impossible, as in figure 6.26.  $\square$

## 6.2.2 Embedded Heawood families

As we mentioned at the beginning of this chapter this family consists of twenty members obtained from  $K_7$  by abstract  $\Delta \leftrightarrow Y$  exchanges, and all are cellularly embedded in the



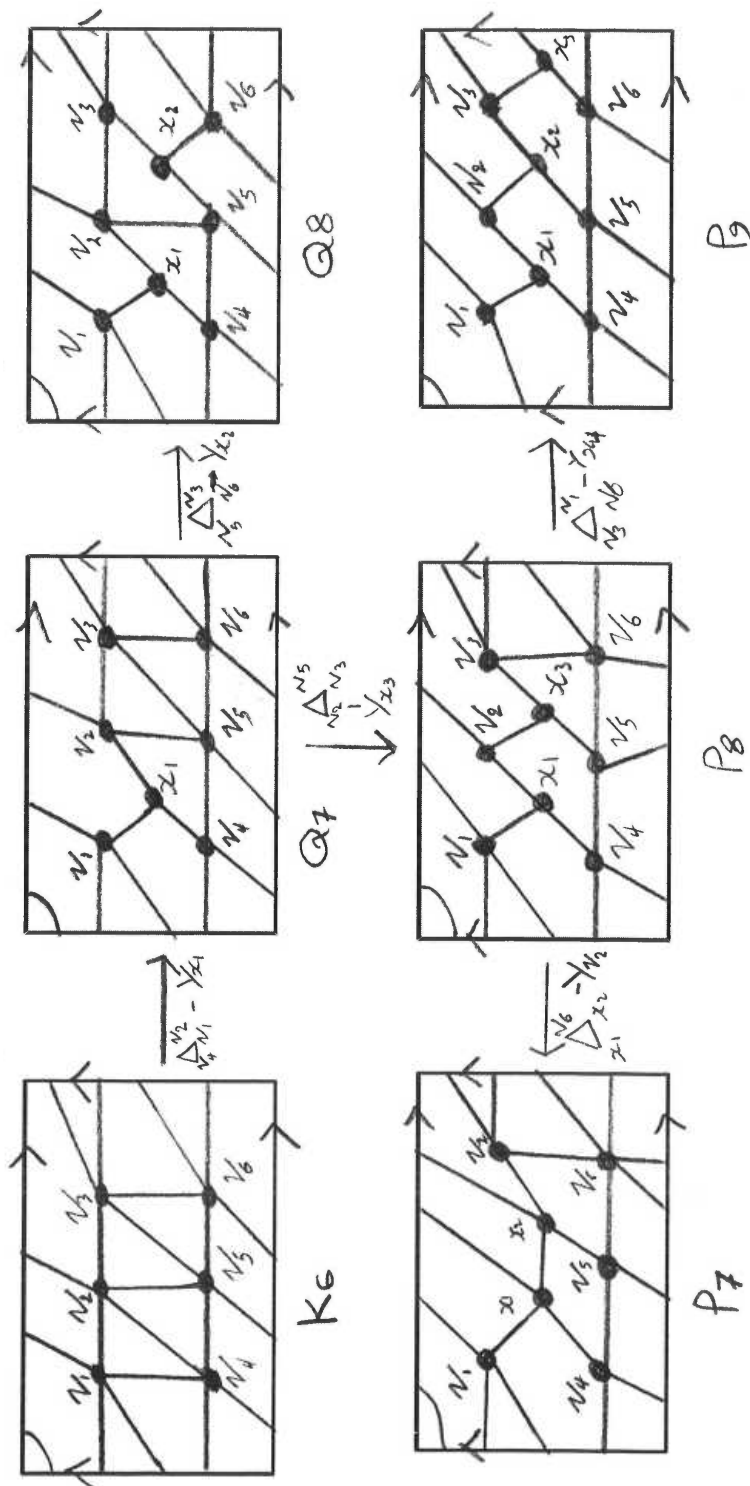

Figure 6.26: Embeddings of some members of Petersen subfamily in the torus.

torus. These embeddings are also not unique, but in cases where we have discussed always get  $\mu = 3$ . It is harder to find the embedding of  $K_7$ , therefore it is not easy to find construct the embedded Heawood families graphs like the embedded Petersen families graphs.

In this section we study two different embeddings of  $K_7$ , each giving rise to a different subfamily of the Heawood family.

In fact, other subfamilies could also be obtained, even for just these two embeddings of  $K_7$ , by making different choices of triangles. But the Heawood family is more complicated than the Petersen family, so we limit ourselves to these result as illustrations of what can happen.

**Theorem 53** *Consider the embedding of  $K_7$  given in figure 6.27. A choice of embedded  $\Delta \leftrightarrow Y$  exchanges gives rise to the subfamily*

$$\mathcal{H}_1 = \{K_7, H_8, H_9, F_9, H_{10}, E_{10}, H_{11}\}.$$

### Proof

In this embedding of  $K_7$  all faces bounding a disc are triangles.

Let us start with triangle  $\{v_1, v_3, v_7\}$  and change it to  $Y_{x_1}$  to get the embedding of  $H_8$  shown in the figure 6.27.

If triangle  $\{v_2, v_4, v_5\}$  is then changed in the embedding of  $H_8$  to  $Y_{x_2}$ , then an embedding of  $H_9$  is obtained, in which this triangle is separated from  $\{v_1, v_3, v_7\}$  in  $K_7$ . To get an embedding of  $H_{10}$  we need to change triangle  $\{v_1, v_2, v_6\}$  to  $Y_{x_3}$ , as in figure 6.27. If, instead, we change triangle  $\{v_3, v_4, v_6\}$  in  $H_{10}$  to  $Y_{x_4}$  we get an embedding of  $H_{11}$ . If the triangle  $\{v_7, v_5, v_6\}$  were changed by an abstract  $\Delta \leftrightarrow Y$  exchanged to  $Y$  in the embedding of  $H_{11}$ , an embedding of  $H_{12}$  would be acquired, but this case is impossible because triangle  $\{v_7, v_5, v_6\}$  does not bound a disc, as can be seen in figure 6.27.

So far, we have five members of this subfamily. Let us return to the embedding of  $H_8$  and choose triangle  $\{v_1, v_2, v_6\}$ , which bounds a disc and has a common vertex with triangle  $\{v_1, v_3, v_7\}$  in  $K_7$ . Change this triangle to  $Y_{x_5}$  to get an embedding of  $F_9$ . From

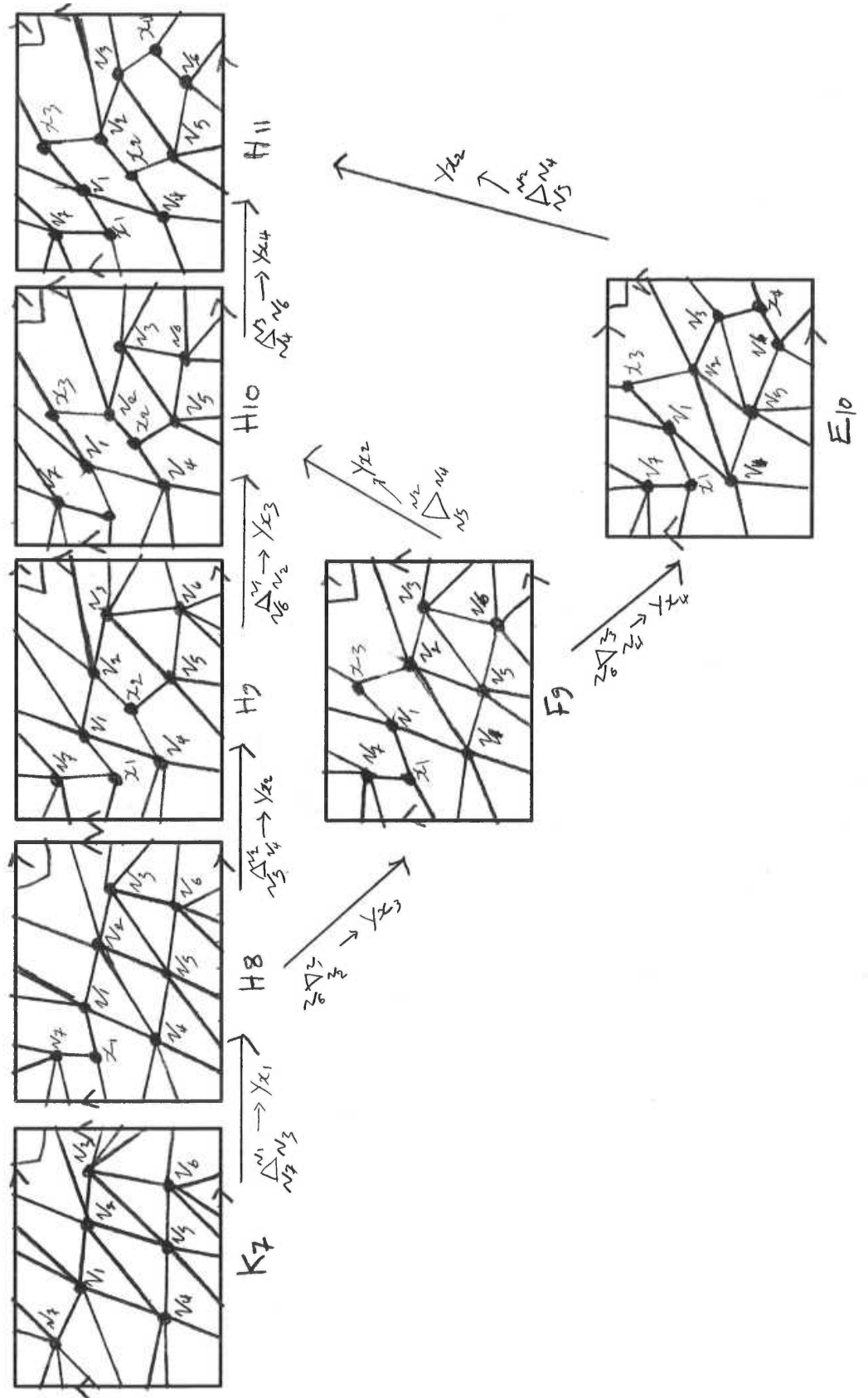

Figure 6.27: An embedding of Heawood subfamily in the torus.

this embedding we can get an embedding of  $E_{10}$  by changing triangle  $\{v_4, v_3, v_6\}$  to  $Y_{x_6}$ , as in figure 6.27. Other members are not possible because they need triangles which do not bound discs. Hence is the desired result.  $\square$

The following theorem constructs another subfamily of  $\mathcal{H}$  containing all members except  $N_{11}$ . We mentioned at the beginning of this section, all members of this subfamily also have a constant  $\mu = 3$ .

**Theorem 54** *Consider the embedding of  $K_7$  is given in figure 6.28. A choice of embedded  $\Delta \leftrightarrow Y$  exchanges gives rise to the subfamily*

$$\mathcal{H}_2 = \mathcal{H} \setminus \{N_{11}\}.$$

**Proof**

We omit the details of the proof of this theorem. They are similar to those in the previous theorem, and can be reconstructed from figure 6.28.  $\square$

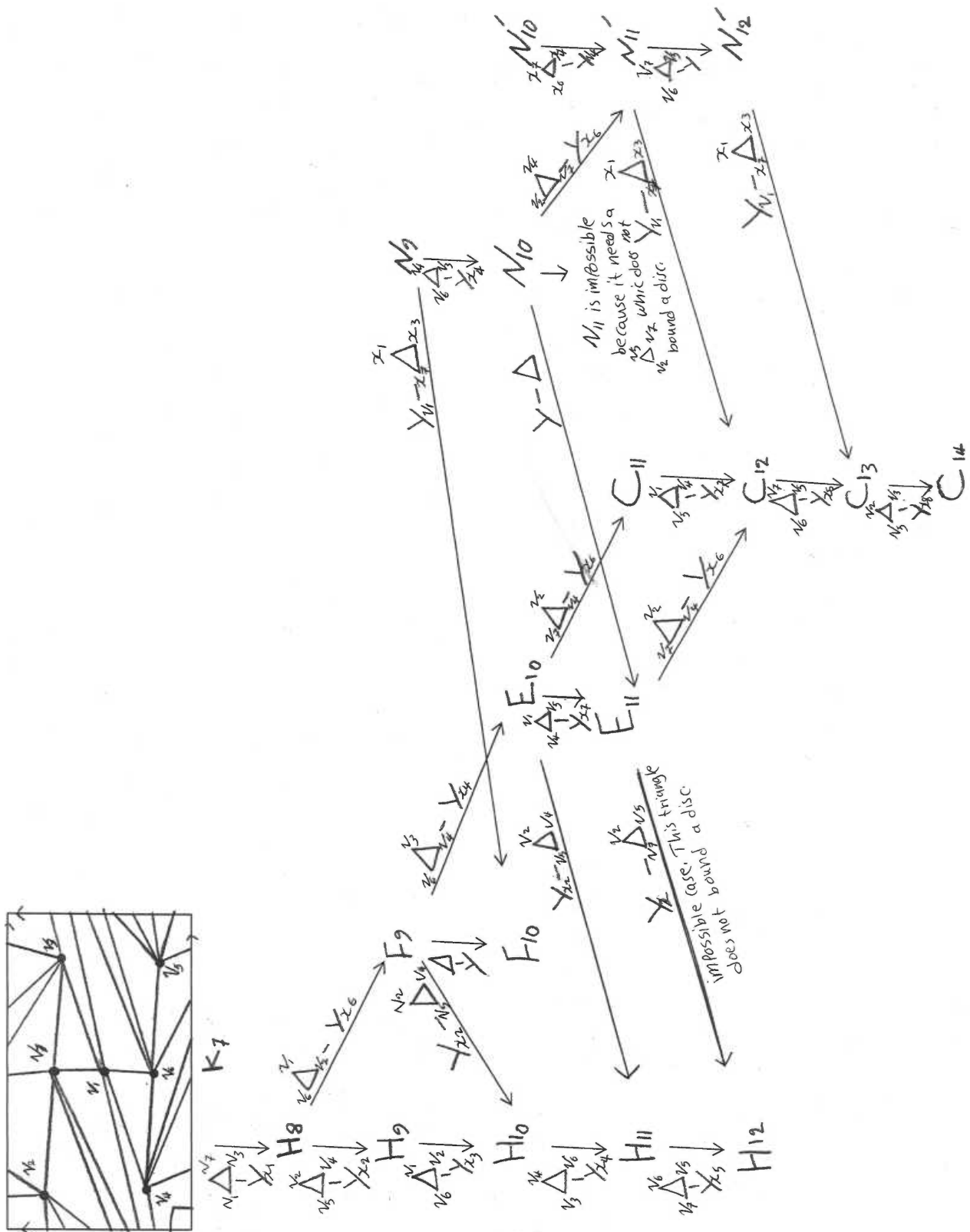

Figure 6.28: An embedding of Heawood subfamily in the torus having the embedding of all members of the Heawood family except the embedding of  $N_{11}$ .



# Chapter 7

## Conclusion and further work

This thesis studied one relationship between knot theory and graph theory, constructed by embedding a graph  $G$  in an orientable surface and determining the corresponding link diagram  $D(G)$  via the medial graph of  $G$ .

This link diagram has  $\mu(D(G))$  components, and we proved that for any connected embedded graph  $G$  on an orientable surface of genus  $g$

$$\mu(D(G)) \leq f(G) + 2g.$$

A cellularly embedded graph  $G$  is called extremal if it has the maximum value of  $\mu$ :

$$\mu(D(G)) = f(G) + 2g.$$

We derived some properties of extremal plane graphs. Some of these properties seemed also to be correct for embedded graphs on the torus, in that we found no counterexamples, but we could not prove them. Therefore we have put them here as conjectures.

**Conjecture 1** *Let  $B_i$  be the blocks of a graph  $G$  cellularly embedded on a surface of genus  $g$ . Then for each  $i$ ,  $B_i$  is a graph which can be cellularly embedded on a surface of genus  $g_i$ , where  $\sum_i g_i = g$ .*

If the graph is embedded on the torus, then the conjecture simply says that one of its blocks is cellularly embedded, and its other blocks are plane graphs.

If this conjecture were true then we would be able to prove (d) in Theorem 27

**d**  $G$  is extremal if and only if each block of  $G$  is extremal.

The following conjecture was proved in the plane. We thought it is true for the extremal graph embedded in the torus, but we so far have not been able to prove it.

**Conjecture 2** *Let  $G$  be an extremal graph on the torus. Then each face of  $G$  is even.*

The converse of this conjecture is not true, as can be seen from the following example.

**Example**

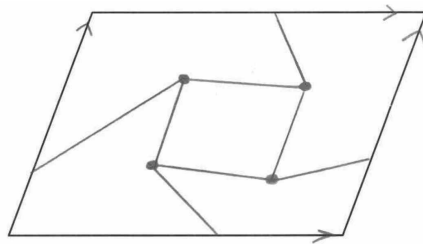

Figure 7.1: An example of a graph having even face but not extremal.

If conjecture 2 is true, then by (9) the dual graph of any extremal graph embedded in the torus is eulerian, because the dual graph of each extremal graph embedded in the torus is a graph having an even degree in each vertex.

**Conjecture 3** *Let  $G$  be an extremal graph on the torus. Then  $G^*$  is eulerian.*

The converse of this conjecture is also not true.

**Example** Figure 7.2 show this example.

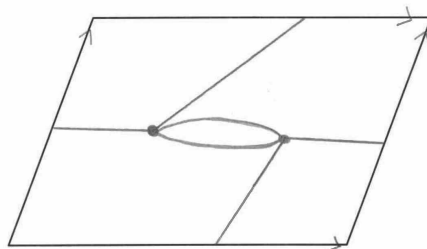

Figure 7.2: An example of a graph which is eulerian but not extremal.

In (9) it was proved that “a graph is bipartite if and only if all its cycles are even.” By using this result the following conjecture will be true if Conjecture 2 is true.



**Conjecture 4** *Let  $G$  be an extremal graph on the torus, then  $G$  is bipartite.*

We also investigated embedded graphs having  $\mu = 1$ .

Finally, we were interested into two families of graphs, the Petersen and Heawood families. All graphs in these two families are embedded on the torus. We identified subfamilies on which  $\mu$  took a constant value, neither the maximum nor the minimum. We obtained several subfamilies of the Petersen family depending on the embedding of  $K_6$ , and also for Heawood family depending on the embedding of  $K_7$ . In the Peterson family we discovered that the value of  $\mu$  depended on the embedding of  $K_6$ .

In further work we aim to study extremal graphs on non-orientable surfaces such as the projective plane and the Klein bottle. We could also investigate graphs with other values of  $\mu(D(G))$  on these surfaces.

We plan to continue to study the Petersen and Heawood families where our conjectures and questions are the following:

1. There are cases of embeddings of  $K_6$  which have the same value of  $\mu(D(K_6))$ . We will try to find common properties among these embeddings.
2. We could try to find all possible values of  $\mu$  taken by different embeddings of  $K_6$ .
3. We will try to find an embedding of  $K_7$  with  $\mu(D(K_7)) \neq 3$ .
4. Is there an embedding of  $K_7$  having a face bounding a disc which is not a triangle?

Furthermore, it may be possible to develop this study through the use of polynomial invariants of knots or graphs.



## List of references

- [1] Adams, C, *The Knot Book*, American Mathematical Society, 2004.
- [2] Alfonsin, J L, *Knots and links in spatial graphs: A survey*, *Discrete Mathematics* **302**, 225–242, 2005.
- [3] Armstrong, M, A, *Basic Topology*, Springer-Verlag, 1983.
- [4] Bollobas, B, *Modern Graph Theory*, Springer-Verlag, 2002.
- [5] Conway, J H, and Gordon, C McA, *Knots and Links in Spatial Graphs*, *Journal of Graph Theory* **7**, 445–453, 1983.
- [6] Cromwell, P, *Knots and Links*, Cambridge University Press, 2004.
- [7] Fellows, M R, and Langston, M A, *Nonconstructive Tools for Proving Polynomial-Time Decidability*, *Journal of the Association for Computing Machinery*, **35**, no. 3, 727–739, 1988.
- [8] Hanaki, R, Nikkuni, R, Taniyama, K, and Yamazaki, A, *On Intrinsically Knotted or Completely 3-Linked Graphs*, arXiv:1006.0698v4 [math.GT].
- [9] Harary, F, *Graph Theory*, Addison-Wesley, 1971.
- [10] Holton, D A, and Sheehan, J, *The Petersen Graph*, Cambridge University Press, 1993.
- [11] Hu, Sze-Tsen, *Elements of General Topology*, Holden-Day, 1964.
- [12] Huggett, S, *On tangles and matroids*, *Journal of Knot Theory and Its Ramifications*, **14**, number 7, 919–929, 2005.

- [13] Huggett, S, and Jordan, D, *A Topological Aperitif*, Springer-Verlag, 2009.
- [14] Huggett, S, and Moffatt, I, *Bipartite partial duals and circuits in medial graphs*, *Combinatorica*, 33, no.2, 231–252, 2013.
- [15] Jin, X, Dong, F, Tay, E, *On graphs determining links with maximal number of component via medial construction*, *Journal of Discrete Applied Mathematics*, **157**, 3099–3110, 2009.
- [16] Las Vergnas, M, *On Eulerian partitions of graphs*, *Research Notes in Mathematics*, **34**, 62–75, 1979.
- [17] Lin, Y, Noble, S D, Jin, X, and Cheng, W, *On plane graphs with link component number equal to the nullity*, *Journal of Discrete Applied Mathematics*, **160**, 1369–375, 2012.
- [18] Martin, P, *Remarkable Valuation of the Dichromatic Polynomial of Planar Multigraphs*, *Journal of Combinatorial Theory B*, **24**, 318–324, 1978.
- [19] Motwani, R, Raghunathan, A, and Saran, H, *Constructive results from graph minors: Linkless embedding*, *Proc. 29th Symposium on the Foundations of Computer Science*, Yorktown Heights, 1988.
- [20] Mphako, E G, *The component number of links from graphs*, *Proceedings of the Edinburgh Mathematical Society*, **45**, 723–730, 2002.
- [21] Noble, S D, Welsh, D J A, *Knot graphs*, *Journal of Graph Theory*, **34**, 100–111, 2000.
- [22] Patterson, E M, *Topology*, Oliver and Boyd, Edinburgh, 1956.
- [23] Pisanski, T, Tucker, T, and Žitnik, A, *Straight-ahead walks in Eulerian graphs*, *Discrete Mathematics*, **281**, 237–246, 2004.
- [24] Lickorish, W B R, *An Introduction to Knot Theory*, Springer-Verlag, 1997.

- [25] Robertson, N, Seymour, P, and Thomas, R, *Sachs' linkless embedding conjecture*, Journal of Combinatorial Theory, Series B, **64** (2), 185–227, 1995.
- [26] Robertson, N, Seymour, P, and Thomas, R, *Linkless embedding of graphs in 3-space*, Bulletin of the American Mathematical Society, **28**, 1, 84–89, 1993.
- [27] Scharlemann, M, and Thompson, A, *Detecting Unknotted Graphs in 3-Space*, J. Differential Geom. **34**, 539–560, 1991.

# Index

- $\mu$ , 2
- $n$ -fan, 7
- $n$ -wheel, 7
- 2-extended, 34
- 2-sum, 34
- 2-thickening, 35
  
- blocks, 6
- bridge, 5
  
- component, 2
- connected sum of two knots, 2
- contracted edge, 4
  
- delete edge, 4
- dual graph, 5
  
- embedded  $Y \leftrightarrow \Delta$ , 6
- embedding, 1
- endvertices of an edge, 3
- even face, 22
- extremal graph in plane, 22
  
- finite graph, 3
- first Reidemeister move, 2
  
- genus, 1
  
- graph  $G$ , 3
  
- Heawood family, 61–63
  
- intrinsically knotted, 9, 68
- intrinsically linked, 9
- intrinsically linked , 63
  
- length of path, 52
- link, 2
- link diagram, 2
- loop, 5
  
- medial graph, 8
- minimum degree, 23
- mod 2 linking number, 2
  
- nonseparable, 6
- nullity, 8
  
- orientable, 1
  
- parallel edges, 5
- Petersen family, 61
- Petersen graph, 62
- plane graph, 3
- pseudo-tree, 8
  
- Reidemeister moves, 2

series edges, 5

simple plane graph, 24

spanning, 3

subgraph, 3

surface, 1

tangle, 3

tensor product, 34

Tutte polynomial, 7

$Y \leftrightarrow \Delta$  exchange, 6

