

**EXTENDED NOTATION
THE DEPICTION OF THE UNCONVENTIONAL**

by

CHRISTIAN DIMPKE

A thesis submitted to the University of Plymouth
in partial fulfilment for the degree of

DOCTOR OF PHILOSOPHY

School of Humanities and Performing Arts
Faculty of Arts

December 2012

Copyright statement

This copy of the thesis has been supplied on condition that anyone who consults it is understood to recognise that its copyright rests with its author and that no quotation from the thesis and no information derived from it may be published without the author's prior consent.

Abstract

Most extended instrumental playing techniques are still deprived of a conventional method of notation. In order to facilitate the utilisation of these unconventional musical elements, a coherent and consistent notation system is developed in this thesis. It comprises chapters on string instruments, wind instruments, percussion instruments, plucked instruments and keyboard instruments. A systematic notation of unconventional instrumental playing techniques has not yet been attempted, nor have all techniques subject to this work yet been explained in detail.

In order to coherently depict unconventional playing techniques, a set of criteria is defined. These criteria postulate that all developments are supposed to be 1. As exact as possible and 2. As simple as possible while the system may 3. Not be contradictory to traditional notation, but should instead extend and be closely related to it. Further, in order to guarantee that the additions are consistent, they need to be compatible with, and distinct from, all other signs of the system.

Each unconventional playing technique is classified and explained in detail. Subsequently, previous methods of its notation are presented and discussed with regard to the previously defined criteria. Finally, a suggestion for the notation that agrees with the postulations is provided. In the next step the application of the developments is then described by presenting examples from compositions that were either produced during the writing of the thesis or revised by replacing old methods of notation with the developments from this thesis. Altogether examples from eight instrumental works that employ the new methods are displayed.

Contents overview

List of figures	13
Chapter 1 Introduction	24
Chapter 2 The techniques of string instruments	51
Chapter 3 The techniques of wind instruments	144
Chapter 4 The techniques of percussion instruments	229
Chapter 5 The techniques of plucked instruments	293
Chapter 6 The techniques of keyboard instruments	343
Chapter 7 Practical example I – Klanggruppen	393
Chapter 8 Practical example II – pieces nos. 2 to 4, 7 and 8	404
Chapter 9 Conclusion	446
Appendix A: IPA chart	460
Appendix B: Piano models	461
Appendix C: Scores and recordings	466
Appendix D: Record of activities	467
List of references	468

Table of contents

List of figures	13
1. Introduction	24
1.1 The criterion of exactness	26
1.2 The criterion of simplicity	29
1.3 The criterion of close relation to traditional notation	30
1.4 Context of the thesis	35
1.5 Pursued approach	42
1.6 Summary	48
2. The techniques of string instruments	51
2.1 Extended <i>pizzicato</i> techniques and their notation	53
2.2 Extended <i>glissando</i> techniques	57
2.2.1 The harmonic- <i>glissando</i> without bowing and its notation	57
2.2.2 The bow- <i>glissando</i>	61
2.2.2.1 Previous methods of notation	62
2.2.2.2 Discussion	65
2.2.2.3 Suggestion for the notation of the bow- <i>glissando</i>	66
2.3 Extended bowing techniques	72
2.3.1 Exaggerated bow pressure	72
2.3.1.1 Previous methods of notation	73
2.3.1.2 Discussion	75
2.3.1.3 Suggestion for the notation of exaggerated bow pressure	77
2.3.2 Extended <i>battuto</i> and <i>tratto</i> techniques and their notation	77
2.3.3 The <i>saltando</i> , <i>balzando</i> and <i>toccato</i> and its notation	82
2.3.4 The rolling bow and its notation	86
2.4 Extended playing positions on the string	88
2.4.1 The highest possible tone and its notation	89
2.4.2 Fingering in between fingerboard and bridge and its notation	91
2.4.3 Bowing on the bridge	93
2.4.3.1 Previous methods of notation	93
2.4.3.2 Discussion	95
2.4.3.3 Suggestion for the notation of bowing on the bridge	96
2.4.4 Playing behind the bridge	98
2.4.4.1 Previous methods of notation	98

2.4.4.2	Discussion	100
2.4.4.3	Suggestion for the notation of bowing behind the bridge	101
2.4.5	Fingering behind the bridge and its notation	102
2.5	Playing exceptional spots	103
2.5.1	Bowing the tailpiece	104
2.5.1.1	Previous methods of notation	104
2.5.1.2	Discussion	105
2.5.1.3	Suggestion for the notation of bowing the tailpiece	105
2.5.2	Bowing the side of the bridge	107
2.5.2.1	Previous methods of notation	107
2.5.2.2	Discussion	108
2.5.2.3	Suggestion for the notation of bowing the side of the bridge	109
2.5.3	Playing the tuning pegs, peg box and scroll	111
2.5.3.1	Previous methods of notation	111
2.5.3.2	Discussion	113
2.5.3.3	Suggestion for the notation of playing the tuning pegs, peg box and scroll	114
2.5.4	Bowing the body of the instrument	115
2.5.4.1	Previous methods of notation	116
2.5.4.2	Discussion	117
2.5.4.3	Suggestion for the notation of bowing the body of the instrument	118
2.6	Extended stopping techniques	119
2.6.1	Half harmonic stops and their notation	120
2.6.2	Exact muting stops and their notation	121
2.7	Percussive effects	125
2.7.1	Strokes on the body and their notation	126
2.7.2	Strokes on the strings and their notation	129
2.8	Preparing the instrument and its notation	133
2.9	Rare extended playing techniques and their notation	135
2.10	Summary	141
3.	The techniques of wind instruments	144
3.1	Extended <i>vibrato</i>, <i>tremolo</i> and trill techniques and their notation	146
3.2	Extended tongue techniques	153
3.2.1	The flutter tongue and its notation	154
3.2.2	The <i>pizzicato</i> effect and its notation	157
3.2.3	The slap tongue	159
3.2.3.1	Previous methods of notation	160
3.2.3.2	Discussion	161

3.2.3.3	Suggestion for the notation of the slap tongue	162
3.2.4	The tongue ram	163
3.2.4.1	Previous methods of notation	164
3.2.4.2	Discussion	165
3.2.4.3	Suggestion for the notation of the tongue ram	165
3.3	Extended embouchure techniques	166
3.3.1	The trumpet embouchure	166
3.3.1.1	Previous methods of notation	167
3.3.1.2	Discussion	168
3.3.1.3	Suggestion for the notation of the trumpet embouchure	169
3.3.2	The closed embouchure and its notation	171
3.3.3	Teeth embouchure	172
3.3.3.1	Previous methods of notation	173
3.3.3.2	Discussion	174
3.3.3.3	Suggestion for the notation of the teeth embouchure	175
3.3.4	The recorder embouchure and its notation	177
3.4	Pitch bending – the extended <i>glissando</i>	178
3.4.1	Previous methods of notation	178
3.4.2	Discussion	180
3.4.3	Suggestion for the notation of pitch bending	181
3.5	Extended blowing techniques	182
3.5.1	The playing and singing technique and its notation	183
3.5.2	The speaking and playing technique and its notation	185
3.5.3	The air and tone technique	188
3.5.3.1	Previous methods of notation	189
3.5.3.2	Discussion	190
3.5.3.3	Suggestion for the notation of the air and tone technique	191
3.5.4	Vocalisation and its notation	193
3.6	Preparing the instrument	194
3.6.1	Detaching the headjoint/mouthpiece/reed/bocal and its notation	195
3.6.2	Constructional modifications and their notation	197
3.7	Whistle techniques	198
3.7.1	Whistle tones and their notation	199
3.7.2	The jet whistle	200
3.7.2.1	Previous methods of notation	201
3.7.2.2	Discussion	202
3.7.2.3	Suggestion for the notation of the jet whistle	202
3.8	Muting	203

3. 8. 1	The application of mutes	203
3. 8. 1. 1	Previous methods of notation	204
3. 8. 1. 2	Discussion	205
3. 8. 1. 3	Suggestion for the notation of the application of mutes	207
3. 8. 2	The wah-wah effect	207
3. 8. 2. 1	Previous methods of notation	208
3. 8. 2. 2	Discussion	208
3. 8. 2. 3	Suggestion for the notation of the wah-wah effect	209
3. 9	Percussive effects	209
3. 9. 1	Key/valve clicks	210
3. 9. 1. 1	Previous methods of notation	210
3. 9. 1. 2	Discussion	211
3. 9. 1. 3	Suggestion for the notation of key/valve clicks	212
3. 9. 2	Strokes on the body	213
3. 9. 2. 1	Previous methods of notation	214
3. 9. 2. 2	Discussion	215
3. 9. 2. 3	Suggestion for the notation of strokes on the body	216
3. 10	Resonance effects	218
3. 4. 1	Previous methods of notation	218
3. 4. 2	Discussion	220
3. 4. 3	Suggestion for the notation of resonance effects	220
3. 11	Rare extended playing techniques and their notation	222
3. 12	Summary	226
4.	The techniques of percussion instruments	229
4. 1	The extension of the percussive apparatus	231
4. 1. 1	Special agents of attack and their notation	231
4. 1. 2	Special percussion instruments and their notation	233
4. 2	Extended modes of attack	233
4. 2. 1	The extended utilisation of the agents of attack	234
4. 2. 1. 1	Previous methods of notation	234
4. 2. 1. 2	Discussion	236
4. 2. 1. 3	Suggestion for the notation of the extended utilisation of the agents of attack	238
4. 2. 2	Extended striking techniques	240
4. 2. 2. 1	Previous methods of notation	240
4. 2. 2. 2	Discussion	241
4. 2. 2. 3	Suggestion for the notation of extended striking techniques	242
4. 2. 3	The point of impact	243
4. 2. 3. 1	Previous methods of notation	243

4.2.3.2	Discussion	245
4.2.3.3	Suggestion for the notation of the point of impact	247
4.2.4	Rubbing and bowing motions	252
4.2.4.1	Previous methods of notation	253
4.2.4.2	Discussion	256
4.2.4.3	Suggestion for the notation of rubbing and bowing motions	258
4.2.5	Articulations without agents of attack	265
4.2.5.1	Previous methods of notation	265
4.2.5.2	Discussion	267
4.2.5.3	Suggestion for the notation of articulations without agents of attack	269
4.2.6	Playing the snares	272
4.2.6.1	Previous methods of notation	272
4.2.6.2	Discussion	274
4.2.6.3	Suggestion for the notation of playing the snares	276
4.3	'Pitch' bending – the extended <i>glissando</i>	278
4.3.1	Previous methods of notation	278
4.3.2	Discussion	279
4.3.3	Suggestion for the notation of 'pitch' bending	280
4.4	Muting	282
4.4.1	The application of mutes and its notation	282
4.4.2	Hand muffling and its notation	282
4.4.3	The stop attack and its notation	286
4.4.4	The wah-wah effect and its notation	287
4.5	Preparing the instrument and its notation	290
4.6	Summary	291
5.	The techniques of plucked instruments	293
5.1	Extended <i>pizzicato</i>, <i>tremolo</i> and trill techniques and their notation	295
5.2	Common and extended playing positions on the string and their notation	298
5.3	Extended <i>glissando</i> techniques	302
5.3.1	The progressive modification of the point of plucking and its notation	303
5.3.2	The pitch bending technique and its notation	305
5.3.3	The vertical <i>glissando</i> with/without plucking	307
5.3.3.1	Previous methods of notation	307
5.3.3.2	Discussion	309
5.3.3.3	Suggestion for the notation of the vertical <i>glissando</i> with/without plucking	311

5.3.4	The harmonic- <i>glissando</i> without plucking and its notation	313
5.3.5	<i>Glissando</i> variants on the harp and their notation	314
5.3.6	The pedal- <i>glissando</i>	316
5.3.6.1	Previous methods of notation	317
5.3.6.2	Discussion	318
5.3.6.3	Suggestion for the notation of the pedal- <i>glissando</i>	319
5.4	Extended modes of attack	321
5.4.1	The <i>toccato</i> and its notation	321
5.4.2	The utilisation of a bow and its notation	322
5.4.3	The utilisation of beaters and its notation	323
5.4.4	Extended <i>battuto</i> techniques and their notation	325
5.4.5	Strumming and its notation	326
5.5	Playing exceptional spots and its notation	327
5.6	Muting and its notation	329
5.7	Extended stopping techniques	331
5.7.1	Exact muting stops and their notation	331
5.7.2	Half harmonic stops and their notation	335
5.7.3	<i>Barré</i> stops and their notation	335
5.8	Percussive effects and their notation	336
5.9	Preparing the instrument and its notation	339
5.10	Summary	340
6.	The techniques of keyboard instruments	343
6.1	Extended <i>pizzicato</i> techniques	344
6.1.1	The <i>pizzicato</i> on the keys and its notation	344
6.1.2	The <i>pizzicato</i> on the strings and its notation	345
6.2	Common and extended playing positions on the strings and their notation	349
6.3	The <i>glissando</i>	350
6.3.1	The <i>glissando</i> on the keys	351
6.3.1.1	Previous methods of notation	351
6.3.1.2	Discussion	353
6.3.1.3	Suggestion for the notation of the <i>glissando</i> on the keys	354
6.3.2	The <i>glissando</i> on the strings and its notation	355
6.3.3	The progressive modification of the point of plucking and its notation	356
6.3.4	The vertical <i>glissando</i> on the strings with/without playing and its notation	357
6.4	Extended modes of attack	360
6.4.1	The <i>toccato</i> and its notation	361

6.4.2	The utilisation of beaters and its notation	361
6.4.3	Extended battuto techniques and their notation	363
6.5	Muting and its notation	363
6.6	Extended stopping techniques	364
6.6.1	Clusters	364
6.6.1.1	Previous methods of notation	365
6.6.1.2	Discussion	367
6.6.1.3	Suggestion for the notation of clusters	367
6.6.2	Depressing the keys silently and its notation	369
6.6.3	Exact muting stops/harmonics and their notation	371
6.6.4	'Half harmonic' stops and their notation	375
6.7	Pedal effects	376
6.7.1	Extended pedal changes	376
6.7.1.1	Previous methods of notation	376
6.7.1.2	Discussion	378
6.7.1.3	Suggestion for the notation of extended pedal changes	379
6.7.2	Pedal strokes	381
6.7.2.1	Previous methods of notation	381
6.7.2.2	Discussion	382
6.7.2.3	Suggestion for the notation of pedal strokes	383
6.8	Percussive effects and their notation	383
6.9	Preparing the instrument and its notation	390
6.10	Summary	391
7.	Practical example I – Klanggruppen	393
7.1	Part A	393
7.2	Part B	397
7.3	Part C	399
7.4	Summary	403
8.	Practical example II – pieces nos. 2 to 4, 7 and 8	404
8.1	Wind instruments	405
8.2	Percussion instruments	411
8.3	Plucked instruments	427
8.4	Keyboard instruments	432
8.5	Summary	445
9.	Conclusion	446
9.1	Discussion	447
9.1.1	On the practicability of the extensions	449

9. 1. 2	On the limitations of the exactness criterion	450
9. 1. 3	On the preferences of composers	450
9. 1. 4	On the constraints of the paper size	452
9. 2	Practical experiences	452
9. 3	Final remarks	457
Appendix A: IPA chart		460
Appendix B: Piano models		461
Appendix C: Scores and recordings on the CD		466
Appendix D: Record of activities		467
List of references		468

List of figures

Please see the respective chapter/list of references for full citation.

1. Introduction

Figure 1: Gubaidulina, Dots, p. 6.

Figure 2: Brown, December 1952, no page named.

Figure 3: Kagel, Staatstheater, p. 3 [Repertoire].

2. The techniques of string instruments

Figure 4: Lachenmann, Staub, no page named [foreword].

Figure 5: Holliger, Duo II, p. 11.

Figure 6: Cervetti, Zinctum, p. 13.

Figure 7: The bow-screw *pizzicato*.

Figure 8: Lachenmann, Pression, p. 2.

Figure 9: The harmonic-*glissando* without bowing.

Figure 10: Scratching over the fingerboard.

Figure 11: The harmonic-*glissando* with a sponge.

Figure 12: Dittrich, Streichquartett III, p. 85.

Figure 13: Haubenstock-Ramati, Séquences, p. 27.

Figure 14: Lachenmann, Torso, p. 3.

Figure 15: Lachenmann, Torso, no page named [foreword].

Figure 16: Dittrich, Streichquartett III, p. 34.

Figure 17: The bow-*glissando* on the common positions.

Figure 18: The extended bow-*glissando*.

Figure 19: Complex motions during the extended bow-*glissando*.

Figure 20: Placing the bow between fingerboard and body.

Figure 21: The bow-*glissando dietro il tasto*.

Figure 22: Ferneyhough, Incipits, no page named [foreword].

Figure 23: Dittrich, Streichquartett III, p. 3.

Figure 24: Crumb, Echoes, p. 12.

Figure 25: Lachenmann, Staub, no page named [foreword].

Figure 26: Henze, 4th string quartet, p. 7.

Figure 27: Kagel, Match, p. 4.

Figure 28: The pressure degrees.

Figure 29: The *de-/crescendo* of pressure degrees.

Figure 30: *Battuto* with the screw.

Figure 31: Lachenmann, Toccata, p. 3.

Figure 32: *Battuto* with the screw on the fingerboard.

Figure 33: Kagel, Streichquartett I/II, p. 12.

Figure 34: Sevsay, Handbuch, p. 81.

Figure 35: Left-hand *battuto*.

Figure 36: The *saltando* and *balzando* techniques.

Figure 37: Lachenmann, Klangschatten, p. 35.

Figure 38: The *col legno toccato*.

Figure 39: Lachenmann, Torso, p. 2.

Figure 40: The rolling bow.

Figure 41: Sevsay, Handbuch, p. 30.

Figure 42: Szalonek, Concertino, p. 4.
 Figure 43: Cervetti, Zinctum, no page named [appendix].
 Figure 44: The highest possible tone.
 Figure 45: The highest possible harmonic.
 Figure 46: Pröve, Firebird, p. 7.
 Figure 47: Fingering in between fingerboard and bridge.
 Figure 48: Sevsay, Handbuch, p. 58.
 Figure 49: Lachenmann, Mouvement, p. 1.
 Figure 50: Lachenmann, Pression, p. 2.
 Figure 51: Holliger, Duo II, p. 21.
 Figure 52: Dittrich, Streichquartett III, p. 2.
 Figure 53: Bowing on the bridge.
 Figure 54: Bowing on the bridge and *sul ponticello* simultaneously.
 Figure 55: Sevsay, Handbuch, p. 58.
 Figure 56: Crumb, Echoes, p. 9.
 Figure 57: Maderna, Widmung, p. 6.
 Figure 58: Penderecki, Threnody, p. 3.
 Figure 59: Lachenmann, Klangschatten, no page named [foreword].
 Figure 60: Lachenmann, Pression, p. 6.
 Figure 61: Playing behind the bridge.
 Figure 62: Fingering behind the bridge.
 Figure 63: Holliger, Duo II, p. 20.
 Figure 64: Lachenmann, Klangschatten, no page named [foreword].
 Figure 65: Lachenmann, Torso, p. 11.
 Figure 66: Bowing the tailpiece.
 Figure 67: Bow-*glissando* on the tailpiece.
 Figure 68: Holliger, Duo II, p. 20.
 Figure 69: Lachenmann, Mouvement, no page named [foreword].
 Figure 70: Lachenmann, Pression, p. 4.
 Figure 71: Bowing the side of the bridge.
 Figure 72: Lachenmann, Toccata, p. 5.
 Figure 73: Lachenmann, Staub, no page named [foreword].
 Figure 74: Lachenmann, Mouvement, no page named [foreword].
 Figure 75: Cervetti, Zinctum, p. 2.
 Figure 76: Lachenmann, Klangschatten, no page named [foreword].
 Figure 77: Bowing the tuning pegs, peg box and scroll.
 Figure 78: Bowing the nut and *pizzicato* in the pegbox.
 Figure 79: Lachenmann, Klangschatten, p. 39.
 Figure 80: Lachenmann, Pression, p. 5.
 Figure 81: Kagel, 1931, p. 4.
 Figure 82: Bowing the body of the instrument.
 Figure 83: Pröve, Firebird, p. 7.
 Figure 84: Kagel, Streichquartett I/II, p. 31.
 Figure 85: Half harmonic stops.
 Figure 86: Stone, Notation, p. 312.
 Figure 87: Lachenmann, Toccata, p. 2.
 Figure 88: Cerha, Enjambements, no page named [foreword].
 Figure 89: The three variants of the buzz-*pizzicato*.
 Figure 90: Kagel, Match, p. 5.
 Figure 91: Szalonek, Concertino, p. 4.

Figure 92: The knuckles and the side of the fist.
 Figure 93: Parts of the hand.
 Figure 94: Strokes on the body.
 Figure 95: The right and left side of a violincello/contrabass.
 Figure 96: Stop attack with the hand.
 Figure 97: Stop attack with the wood of the bow.
 Figure 98: Holliger, Duo II, p. 13.
 Figure 99: Kagel, Streichquartett, p. 1.
 Figure 100: Kagel, Streichquartett I/II, p. 20.
 Figure 101: Lachenmann, Torso, p. 14.
 Figure 102: Playing under the strings in between fingerboard and bridge.
 Figure 103: Playing under the strings behind the bridge.
 Figure 104: Holliger, Duo II, p. 20.
 Figure 105: Scratching *sulla cordiera*.
 Figure 106: Kagel, Streichquartett I/II, p. 32.
 Figure 107: Blowing into the instrument.

3. The techniques of wind instruments

Figure 108: Bartolozzi, Klänge, p. 27.
 Figure 109: Ferneyhough, Mnemosyne, p. 1.
 Figure 110: The *smorzato*.
 Figure 111: Levine and Mitropoulos-Bott, Flute, p. 42.
 Figure 112: Sevsay, Handbuch, p. 147.
 Figure 113: Gallois, Bassoon, p. 65.
 Figure 114: The *bisbigliando* effect.
 Figure 115: Kelemen, Changeant, p. 44.
 Figure 116: Serocki, Segmenti, p. 4.
 Figure 117: Berio, Gesti, p. 3.
 Figure 118: Xenakis, Linaia, p. 13.
 Figure 119: Xenakis, Linaia, p. 3.
 Figure 120: Michael, Invocaciones, p. 6.
 Figure 121: Holliger, Pieces, p. 5.
 Figure 122: Kagel, Schattenklänge, p. 3.
 Figure 123: Weiss and Netti, Saxophone, p. 146.
 Figure 124: The slap tongue articulation.
 Figure 125: Hosokawa, Sen I, p. 4.
 Figure 126: Sciarrino, Giardino, p. 30.
 Figure 127: Braun, Tuba, p. 4.
 Figure 128: The tongue ram effect.
 Figure 129: Holliger, Sonate, p. 4.
 Figure 130: The trumpet embouchure and the transposition system.
 Figure 131: Holliger, Sonate, p. 4.
 Figure 132: Dittrich, – the – m –, p. 25a.
 Figure 133: Serocki, Swinging, p. 12.
 Figure 134: Lachenmann, Niente, no page named [foreword].
 Figure 135: Holliger, Pneuma, p. 6.
 Figure 136: The teeth embouchure.
 Figure 137: Lachenmann, Allegro, p. 11.
 Figure 138: Kelemen, Changeant, p. 29.

Figure 139: Ferneyhough, Incipits, p. 19.
Figure 140: Foss, Echoi, p. 28.
Figure 141: Köszeghy, Mortualium, p. 5.
Figure 142: Dick, Klang, p. 8.
Figure 143: Pitch bending on the B \flat clarinet.
Figure 144: Michael, Epigramme, p. 6.
Figure 145: Hosokawa, Sen I, p. 9.
Figure 146: Crumb, Echoes, p. 18.
Figure 147: Sotelo, Aura, p. 13.
Figure 148: Speaking and playing.
Figure 149: Nono, Klarsein, p. XIV.
Figure 150: Kagel, Schattenklänge, p. 2.
Figure 151: Katzer, Dialog, p. 1.
Figure 152: Air and tone.
Figure 153: Gallois, Bassoon, p. 22.
Figure 154: Vocalisation.
Figure 155: Weiss and Netti, Saxophone, p. 149.
Figure 156: Szalonek, Concertino, p. 3.
Figure 157: Playing on the headjoint of a flute.
Figure 158: Sciarrino, All'aure, p. 6.
Figure 159: Lachenmann, Gefühle, no page named [foreword].
Figure 160: Holliger, Sonate, p. 4.
Figure 161: Lachenmann, Staub, no page named [foreword].
Figure 162: The jet whistle.
Figure 163: Halffter, Lineas, p. 7.
Figure 164: Kelemen, Changeant, p. 29.
Figure 165: Ligeti, Apparitions, p. 2.
Figure 166: Kagel, Atem, p. 4 [foreword].
Figure 167: Holliger, Siebengesang, p. 58.
Figure 168: Berio, Sequenza X, p. 7.
Figure 169: Lachenmann, Gefühle, p. 47.
Figure 170: Saariaho, Laconisme, p. 4.
Figure 171: Lachenmann, Staub, no page named [foreword].
Figure 172: Varèse, Density, p. 2.
Figure 173: Gaber, Voce II, no page named [foreword].
Figure 174: Key clicks.
Figure 175: Ligeti, Aventures, p. 6.
Figure 176: Lachenmann, NUN, p. V.
Figure 177: Alsina, Consecuenza, p. 7.
Figure 178: Strokes on the body of a trumpet.
Figure 179: Lachenmann, Gefühle, p. 43.
Figure 180: Berio, Sequenza X, no page named [foreword].
Figure 181: Foss, Echoi, p. 29.
Figure 182: Resonance effects on the grand piano.
Figure 183: Lachenmann, Mouvement, no page named [foreword].
Figure 184: Breath accents.
Figure 185: Moving the bell.

4. The techniques of percussion instruments

- Figure 186: Szalonek, Concertino, p. 3.
Figure 187: Kagel, Dressur, no page named [foreword].
Figure 188: Redel, Musik, p. 2.
Figure 189: Penderecki, Dimensions, p. 4.
Figure 190: Lachenmann, Accanto, p. 2.
Figure 191: Kagel, Match, p. 23.
Figure 192: Kagel, Match, p. 23.
Figure 193: Lachenmann, Accanto, p. 18.
Figure 194: The normal attack and the extended utilisation of the beater.
Figure 195: Lachenmann, NUN, p. VIII.
Figure 196: Kagel, Anagrama, p. 23.
Figure 197: Zimmermann, Canto, no page named [foreword].
Figure 198: Lachenmann, Staub, no page named [foreword].
Figure 199: Kotoński, Batterie, p. 3.
Figure 200: Redel, Rounds, no page named [appendix].
Figure 201: Varèse, Ionisation, p. 21.
Figure 202: Kagel, Bruit, p. 11a.
Figure 203: Penderecki, Fluorescences, p. 3.
Figure 204: Complex attacks on a bass drum.
Figure 205: Hitting the shell of a timpano.
Figure 206: Strokes on the front and back of a cymbal.
Figure 207: Striking a drumstick lying on the surface of an instrument.
Figure 208: Striking different spots simultaneously.
Figure 209: Six rim shot variants.
Figure 210: Nono, Dallapiccola, p. 1 [reproduction of the score].
Figure 211: Eloy, Equivalences, no page named [foreword].
Figure 212: Lachenmann, Staub, no page named [foreword].
Figure 213: Lachenmann, NUN, p. IX.
Figure 214: Stockhausen, Mikrophonie I, Moment "TUTTI forte".
Figure 215: Lachenmann, Accanto, p. 13.
Figure 216: Szalonek, Concertino, p. 4.
Figure 217: Halffter, Fibonaciana, p. 24.
Figure 218: Lachenmann, Air, p. 47.
Figure 219: Singular rubbing motions.
Figure 220: Repetitive rubbing motions.
Figure 221: Rubbing motions on the resonators of a vibraphone.
Figure 222: 'Circular' rubbing motions.
Figure 223: Complex motions with two beaters.
Figure 224: Rubbing motions that involve the rim.
Figure 225: Bowing percussion instruments.
Figure 226: Lachenmann, NUN, p. X.
Figure 227: Kagel, Bruit, p. 10a.
Figure 228: Kagel, Match, p. 8.
Figure 229: Stockhausen, Kontakte, p. 5.
Figure 230: Kagel, Bruit, p. 30a.
Figure 231: Striking and swinging a Chinese cymbal.
Figure 232: Special rubbing motions.
Figure 233: Special circular motions.

Figure 234: Spinning and shaking a concert bongo.
 Figure 235: Dropping items into/on instruments.
 Figure 236: Kagel, 1931, p. 91.
 Figure 237: Holliger, *Pneuma*, p. 37.
 Figure 238: Kagel, *Bruit*, p. 6a.
 Figure 239: Kagel, *Bruit*, p. 7a.
 Figure 240: Playing on the snares.
 Figure 241: Motions on the snares and head.
 Figure 242: Stone, *Notation*, p. 223.
 Figure 243: Cage, *First construction*, p. 5.
 Figure 244: Crumb, *Mundus*, p. 8.
 Figure 245: 'Pitch' bending and shifting the point of impact.
 Figure 246: Lachenmann, *NUN*, p. VII.
 Figure 247: Foss, *Echoi*, p. 18.
 Figure 248: Hand muffling (*lasciar vibrare*).
 Figure 249: Hand muffling (*non lasciar vibrare*).
 Figure 250: Lachenmann, *NUN*, p. VII.
 Figure 251: The stop attack.
 Figure 252: Kagel, *Fürst*, p. 11.
 Figure 253: Stone, *Notation*, p. 223.
 Figure 254: The wah-wah effect on a hi-hat.

5. The techniques of plucked instruments

Figure 255: The tuning key *pizzicato*.
 Figure 256: The lateral *Bartók pizzicato* on two adjacent strings.
 Figure 257: The *bisbigliando* effect.
 Figure 258: Fingering in between fretboard and saddle.
 Figure 259: Playing on the fretboard.
 Figure 260: The progressive modification of the point of plucking on the guitar.
 Figure 261: Pitch bending on the harp.
 Figure 262: Kelemen, *Changeant*, p. 46.
 Figure 263: Stone, *Notation*, p. 255.
 Figure 264: Kagel, *Anagrama*, p. 9.
 Figure 265: Holliger, *Partita (II)*, p. 20.
 Figure 266: Sevsay, *Handbuch*, p. 238.
 Figure 267: The vertical *glissando* with/without plucking.
 Figure 268: The *trémolo éoliens* or trill-*glissando*.
 Figure 269: Berio, *Sequenza II*, p. 1.
 Figure 270: Kagel, *Sonant*, p. 21.
 Figure 271: Holliger, *Partita (II)*, p. 24.
 Figure 272: The pedal-*glissando*.
 Figure 273: The extended trill with items.
 Figure 274: Brouwer, *Elogio*, p. 5.
 Figure 275: Strumming.
 Figure 276: *Pizzicato* on the neck.
 Figure 277: The normal muting.
 Figure 278: Isolated tones (*lasciar vibrare*).
 Figure 279: Exact muting stops on the harp.
 Figure 280: Cluster muting with a threaded rod.

- Figure 281: The buzz-*pizzicato* on the harp.
 Figure 282: Lachenmann, Salut, no page named [foreword].
 Figure 283: Strokes on the body of a harp.
 Figure 284: *Sons timbaliques*.

6. The techniques of keyboard instruments

- Figure 285: Lachenmann, Guero, no page named [foreword].
 Figure 286: Stone, Notation, p. 263.
 Figure 287: Henze, Sinfonia N. 6, p. 7.
 Figure 288: Kagel, Norden, p. 85.
 Figure 289: Brahms, Hungarian, p. 28.
 Figure 290: The diatonic and chromatic key *glissando*.
 Figure 291: The vertical *glissando* with/without plucking.
 Figure 292: Cowell, Vestiges, p. 3.
 Figure 293: Cowell, Vestiges, p. 3.
 Figure 294: Cage, Holocaust, p. 29.
 Figure 295: Kagel, Anagrama, p. 6.
 Figure 296: Diatonic and chromatic clusters.
 Figure 297: Additive and subtractive *glissandi*.
 Figure 298: Schoenberg, Drei Klavierstücke, p. 3.
 Figure 299: Silently depressed diatonic and chromatic clusters.
 Figure 300: Exact muting stops/harmonics and playing on the keyboard.
 Figure 301: Exact cluster muting stops/harmonic clusters.
 Figure 302: Kagel, Passé, p. 26.
 Figure 303: Stockhausen, Klavierstück VI, p. 25.
 Figure 304: Sevsay, Handbuch, p. 264.
 Figure 305: Gradual pedal changes.
 Figure 306: Delás, Outremer, p. 31.
 Figure 307: Sevsay, Handbuch, p. 265.
 Figure 308: Pedal changes and strokes.
 Figure 309: The interior of a grand piano.
 Figure 310: Strokes on the keyboard lid and wooden strip.
 Figure 311: Cage, Changes III, p. 62.
 Figure 312: Slamming and opening the keyboard lid.
 Figure 313: The diatonic and chromatic *glissando* without depressing the keys.
 Figure 314: Glissandi on the tuning pins.

7. Practical example I: Klanggruppen

- Figure 315: Klanggruppen, p. 1.
 Figure 316: Klanggruppen, p. 2.
 Figure 317: Klanggruppen, p. 3.
 Figure 318: Klanggruppen, p. 4.

7. Practical example II: Pieces nos. 2 to 4, 7 and 8

- Figure 319: Materialbegriff, p. 1.
 Figure 320: Materialbegriff, p. 2.
 Figure 321: Materialbegriff, p. 30.
 Figure 322: Materialbegriff, p. 9.

Figure 323: Entgleisungen, p. 12.
Figure 324: Entgleisungen, p. 12.
Figure 325: Materialbegriff, p. 15.
Figure 326: Materialbegriff, p. 1.
Figure 327: Materialbegriff, p. 1.
Figure 328: Entgleisungen, p. 17.
Figure 329: Materialbegriff, p. 12.
Figure 330: Filterspiel, no page named [foreword].
Figure 331: Entgleisungen, p. 23.
Figure 332: Filterspiel, p. 2.
Figure 333: Filterspiel, p. 6.
Figure 334: Filterspiel, p. 3.
Figure 335: Filterspiel, p. 6.
Figure 336: Entgleisungen, p. 19.
Figure 337: Entgleisungen, p. 22.
Figure 338: Filterspiel, p. 4.
Figure 339: Filterspiel, p. 3.
Figure 340: Filterspiel, p. 3.
Figure 341: Entgleisungen, p. 14.
Figure 342: Filterspiel, p. 15.
Figure 343: Filterspiel, p. 9.
Figure 344: Entgleisungen, p. 12.
Figure 345: Filterspiel, p. 15.
Figure 346: Entgleisungen, p. 1.
Figure 347: Filterspiel, p. 12.
Figure 348: Filterspiel, p. 1.
Figure 349: Entgleisungen, p. 6.
Figure 350: Filterspiel, p. 13.
Figure 351: Entgleisungen, p. 3.
Figure 352: Entgleisungen, p. 31.
Figure 353: Filterspiel, p. 21.
Figure 354: Filterspiel, p. 19.
Figure 355: Entgleisungen, p. 1.
Figure 356: Filterspiel, p. 13.
Figure 357: Filterspiel, p. 5.
Figure 358: Filterspiel, p. 26.
Figure 359: Entgleisungen, p. 37.
Figure 360: Filterspiel, p. 4.
Figure 361: Filterspiel, p. 4.
Figure 362: Filterspiel, p. 25.
Figure 363: Songs, p. 1.
Figure 364: Songs, p. 1.
Figure 365: Songs, p. 1.
Figure 366: Songs, p. 13.
Figure 367: Songs, p. 15.
Figure 368: Songs, p. 17.
Figure 369: Songs, p. 7.
Figure 370: Songs, p. 4.
Figure 371: Songs, p. 5.
Figure 372: Songs, p. 13.

Figure 373: Entgleisungen, p. 6.
Figure 374: Entgleisungen, p. 41.
Figure 375: Interventionen, p. 1.
Figure 376: Interventionen, p. 4.
Figure 377: Entgleisungen, p. 17.
Figure 378: Entgleisungen, p. 28.
Figure 379: Entgleisungen, p. 29.
Figure 380: Interventionen, p. 3.
Figure 381: Interventionen, p. 6.
Figure 382: Entgleisungen, p. 40.
Figure 383: Entgleisungen, p. 23.
Figure 384: Interventionen, p. 12.
Figure 385: Entgleisungen, p. 1.
Figure 386: Interventionen, p. 12.
Figure 387: Interventionen, p. 1.
Figure 388: Interventionen, p. 2.
Figure 389: Entgleisungen, p. 27.
Figure 390: Interventionen, p. 12.
Figure 391: Entgleisungen, p. 41.
Figure 392: Interventionen, p. 13.
Figure 393: Entgleisungen, p. 11.
Figure 394: Interventionen, p. 4.
Figure 395: Entgleisungen, p. 6.
Figure 396: Entgleisungen, p. 35.

Acknowledgements

I would like to sincerely thank my first supervisor Prof Eduardo Miranda for his constant support, his suggestions and for believing in the importance of the thesis. Without him I could not have written the work. I would also like to thank my second supervisor Dr David Bessell for his great help during the process of writing the thesis.

Further, I would like to express my sincere appreciation to the University of Plymouth's Graduate School for the studentship I was awarded. It enabled me to fully focus on the thesis as a full time student.

Finally, I would like to give thanks to the colleagues I had the chance to meet at the Interdisciplinary Centre for Computer Music Research, especially Alexis Kirke, Noris Mohd Norowi and Hanns Holger Rutz. It was a pleasure working with you.

Author's declaration

At no time during the registration for the degree of Doctor of Philosophy has the author been registered for any other university award without prior agreement of the Graduate Committee.

This study was financed with the aid of a studentship from the Centre for Humanities and Performing Arts Research (HuMPA) of the University of Plymouth.

A record of activities can be found in Appendix D.

Word count of main body of the thesis: 108,957

Berlin, 17 December 2012

(Christian Dimpker)

1. INTRODUCTION

The origin of this thesis lies within a piece I composed in January 2010 called *Tatsachen in zwei Sätzen*¹ for violin alone. In this work I utilised a large number of extended instrumental playing techniques. However, the employment of uncommon ways of sound production caused a lot of difficulties. This was because for most of the playing techniques applied in the piece a conventional method of notation had not been established. When willing to make use of such techniques, one is hence forced to develop one's own methods or select existing unconventional methods that serve one's needs and explain these sufficiently whilst the interpreters are then confronted with the task to comprehend the new notations before they can start rehearsing.

In the course of the year, I further extensively studied the extended playing techniques of woodwinds, the piano, percussion instruments and string instruments during the composition process of a piece called *Entgleisungen*² for flute, B \flat clarinet, piano, percussion, violin and violincello as well as a piano work called *Zu vier Händen – Interventionen für Konzertflügel*³ for piano and assistance. The examination of the technical instrumental possibilities and methods of their notation resulted in the desire to develop a coherent system of depiction for the unconventional means of instrumental sound production. I thought that such a system would, firstly, simplify the composition process because one would no longer be forced to either develop methods of notation before actually starting with a composition or *ad hoc* invent such methods during the writing of a piece. Secondly, if adopted by other composers, it could facilitate the performance of extended playing techniques because the instrumentalists could become used to these methods of notation.

¹ Facts in two movements.

² Derailments.

³ For four hands – Interventions for grand piano.

In this thesis a coherent and consistent notation system for most of the unconventional extended instrumental playing techniques is developed with regard to string instruments, wind instruments, percussion instruments, plucked instruments and keyboard instruments. In order to fulfil this task, a set of criteria is defined. It may be used to judge previous methods of notation. On the basis of such analyses, new methods that completely agree with the postulations are then designed. In order to verify their practicability, musical works that make use of the methods are composed. Moreover, the subsequent realisation of these pieces could show how the methods are adopted by the interpreters and whether they are suitable for the depiction of the respective technique.

The criteria used within this thesis have evolved during my practice as a composer when studying and developing methods of notation for extended playing techniques. However, they might not be accepted by all other composers. This is because by implementing them, some methods of notation – that might be regarded as a useful way of depicting unconventional musical elements – are rejected. After defining the criteria, it is, therefore, explained why they are considered to be important, shown which methods of notation are rejected by employing them as well as which methods of notation agree with the premisses and may hence be utilised for the development of a coherent system that depicts the unconventional. Nevertheless, it needs to be noted that even though there are good reasons for postulating these criteria, they remain subjective, and anyone who cannot accept them might not be satisfied with the results of this work. In such a case, other methods may be, however, derived from the presented suggestions and this thesis be used to study unconventional instrumental playing techniques.

In order to coherently depict all playing techniques subject to this work, three criteria are postulated. These criteria require that all suggested methods of notation are

1. **As exact as possible.**
2. **As simple as possible.**
3. **Not contradictory to traditional notation, but should instead extend and be closely related to it.**

Further, in order to guarantee that the additions are legitimate and consistent, they need to be – as Dahlhaus declares – **compatible with, and distinct from, all other signs of the system**¹.

1. 1 The criterion of exactness

The criterion of exactness is related to the fundamental function of notation systems, as defined by Wittgenstein in the *Tractatus logico-philosophicus*². In this work Wittgenstein equates the natural sciences with musical notations: “[a] gramophone record, the musical idea, the written notes, and the sound-waves, all stand to one another in the same internal relation of depicting that holds between language and the world. They are all constructed according to a common logical pattern”³. Generally, all sonic events can be regarded as facts. This is because the production of a sound can be repeated and observed. When the parameters are the same, the experiment will always lead to the same result. However, there are better and worse pictures of facts: “[a] picture agrees with reality or fails to agree; it is correct or incorrect, true or false. (...) The agreement or disagreement of its sense with reality constitutes its truth or falsity”⁴. With regard to

¹ Carl Dahlhaus: Notenschrift heute [Notation today]. In: Ernst Thomas (ed.): Notation Neuer Musik [Notation of New Music]. Darmstädter Beiträge zur Neuen Musik IX [Darmstadt’s contributions to New Music IX]. Mainz 1965, pp. 9-34, here: pp. 15f.

² Cf. Ludwig Wittgenstein: *Tractatus logico-philosophicus*. Translation by D. F. Pears and B. F. McGuinness. Reprinted with corrections. London et al. 1972, pp. 7-49 [odd pages in English].

³ *Ibid.*, p. 39.

⁴ *Ibid.*, pp. 17 and 19.

music, pictures that agree with reality can be described as exact notations whilst pictures that fail to agree with reality are inexact or approximate. When being in possession of an exact picture of a musical fact, it is possible to re-use it with the certainty that it will always result in the desired sound. Therefore, the criterion of exactness is postulated here. It aims at creating correct depictions of musical facts and developing notation systems that are as clear as the depiction of a tone produced by an acoustic instrument.

The verification of this criterion is reliant on conducting several experiments. This means that a method of notation that tries to depict a particular fact is examined by making various performers realise it and hence produce the notated sound. When the results equal each other, a particular method may be described as exact. However, such an observation requires a large number of performers and huge effort. This is why a sufficient number of experiments could not be conducted during the making of this thesis. But nevertheless, it could be investigated which parameters the production of a particular sound involves and if they are adequately represented in the depiction. The more parameters a particular method of notation describes, the more exact it is. Another limitation to the criterion of exactness is the factor of interpretation, which leads to the creation of versions of the same piece. When interpreting a piece, the performers bring the work into existence by means of artistic expression. This may lead to an uncertainty between the picture of and the realised sonic events. Another reason for the uncertainty between the depiction and the realisation is the human factor of inaccurate performance, e. g. slight deviations between the requested and the actual tempo. The liberty of interpretation is, however, always dependent on the exactness of the underlying notation system. The less exact it is, the more will the versions differ from each other and vice versa. Further, inaccuracy is only a small factor when working with highly-trained

performers. But nevertheless, it needs to be admitted that the factors of interpretation and inaccuracy limit the exactness of a notation system.

When determining that the developments are supposed to be as exact as possible, two inexact methods of notation called **qualitative notation** and **approximate notation**, need to be excluded. To give an example, Pousseur, in *Caractères 1a, 1b*¹, makes use of qualitative notation. The metre is, in this work, supposed to be derived from numbers, “which appear either in place of normal tempo indications (...) or above the chrometric subdivision in question”². They are “not to be regarded in a strict quantitative sense”³, but “are symbols for the concrete values of an approximated, progressive scale (...). All these values must be felt as units, whose relations are of a qualitative nature”⁴. By introducing such a method of notation, the performer is liberated from the determination of a strict metre. Further, Gubaidulina, in *Dots, lines and zigzag*⁵, makes use of approximate notation. She does, for instance, not use traditional rests, but six unspecified replacements – 1. ♪ 2. ” 3. ”” 4. ^ 5. ∩ 6. □⁶ – that need to be interpreted by the instrumentalists. Moreover, two playing techniques are notated in an approximate way, the *glissando* on the piano’s bass strings and the pitch bending⁷ of the clarinet. As can be seen in figure 1, the range of the bass strings is indicated by a two-headed arrow whilst the *glissando* action is depicted by means of a line that approximately describes the motion the pianist is supposed to perform. Simultaneously, the clarinetist produces harmonics. Gubaidulina determines that the pitch of the harmonics is approximate

¹ Henri Pousseur: *Caractères 1a, 1b*. Piano solo. Vienna 1962.

² *Ibid.*, no page named [foreword].

³ *Ibid.*, no page named [foreword].

⁴ *Ibid.*, no page named [foreword].

⁵ Sofia Gubaidulina: *Dots, lines and zigzag*. For bass clarinet and piano. Hamburg 1995.

⁶ Cf. *ibid.*, p. 2.

⁷ On the clarinet the pitch can be adjusted via changes in lip tension or embouchure and/or opening and closing tone holes. This technique is referred to as pitch bending (cf. section ‘3. 4 Pitch bending – the extended *glissando*’).

whilst the pitch bending technique is depicted similarly to the *glissando* on the bass strings by a line. However, when postulating exactness, qualitative and approximate notation need to be excluded because – as apparent from the examples – in both methods the parameters are only approximately indicated¹.

*) Flageolett-Akkorde, ungefähre Tonhöhe / Chordal harmonics, approximate pitch
 **) Glissandi auf den Baßsaiten / Glissandos on the bass strings
 ***)  = Ziffer / fig. 15 - 16 quasi Cadenza, improvvisare ad lib.

H.S. 1870

Fig. 1 Gubaidulina, Dots, p. 6.

1. 2 The criterion of simplicity

The criterion of simplicity is related to the introduction of new methods of notation. As mentioned, it is necessary to explain these to performers who are supposed to realise a particular work. Their task is to comprehend the explanation, presumably learn uncommon playing techniques and their notation as well as – after having done so – to rehearse the piece. In order to facilitate the performance, it is hence necessary to construct the notation system – which depicts the unconventional elements – in the simplest possible way. However, it needs to be noted that the method of depiction can be only as simple as the sonic material it is trying to depict. When the production of a sound is very complicated because it involves many parameters or complex actions, the method of notation needs to adapt. This criterion can also be verified by conducting expe-

¹ Cf. Erhard Karkoschka: Notation in New Music. A critical guide to interpretation and realisation. Translation by Ruth Koenig. 1st published in German 1966. New York and Washington 1972, p. 3.

periments. Any experiment, i. e. realisation, helps examine the practicability and hence simplicity of the developments.

1.3 The criterion of close relation to traditional notation

The postulation of simplicity is linked to the third criterion. This is because the depiction of unconventional sonic events is easier to understand when they are constructed with regard to the common method of notation because instrumentalists are used to traditional notation. By contrast, the introduction of a fundamentally different notation system would cause the performers a great deal of additional work and might lead to rejection or irritation. This might have been the reason why, for example, the reform attempts *Klavarscribo* or *Equitone* have not been established¹. Moreover, since the traditional system is, and will be, utilised to depict the conventional elements of music and there is, further, no need to replace it – because the common elements of notated music can be adequately depicted by this system – additional elements can be only introduced when they do not interfere with the conventional elements. When doing so, the unconventional may be combined with the conventional and the interpreters' effort be reduced.

In order to fulfil the third criterion, two main elements of traditional notation need to be, in any case, preserved. These are, respectively, the traditional durations or the time axis and the instantaneous comprehension. The latter rests upon learnable directions, e. g. *sul ponticello*, symbols, e. g. for the *Bartók pizzicato*, diagrams or schemes (see below). When these can be read and understood in a quick manner, the performer may simultaneously read and play or the recipient read and listen, respectively. The instan-

¹ Cf. *ibid.*, pp. 11-15.

taneous comprehension is not only fundamental for the performance of music, but also adds a visual level of perception to an acoustic work of art.

The postulation of the premisses 1 and 3 leads to the exclusion of two methods called **graphic notation** and **descriptive notation**. In the lexicon graphic notation is characterised as the final stage of a random and approximate method of notation, which does not indicate any musical relations. Further, Goebels defines musical graphics as pure drawings without verbal comment or constricting semantic determination of signs and adds that graphic notation does not make use of an obligatory sign system¹. However, most works that make use of graphic notation imply a relation between the utilised signs and the realisation. An example for such a method of notation is Brown's *December 1952*², which is presented in figure 2. In the foreword Brown explains how the score is supposed to be read: "[t]he composition may be performed in any direction from any point in the defined space for any length of time (...). [T]he thickness of the event indicates the relative intensity and/or (where applicable instrumentally) clusters". Hence even though the interpretation of the score is arbitrary, the drawings have semantic content. In other works of the same kind, as Logothetis' *Styx*³ or Moran's *Four visions*⁴, the employed signs are, for instance, related to articulations, the dynamic level or the tempo. Generally, what graphic notations have in common is that the interpreter needs to become a composer when performing them⁵. This is because these notations are very

¹ Franzpeter Goebels: *Gestalt und Gestaltung musikalischer Grafik* [Shape and design of musical graphics]. In: *Melos. Zeitschrift für Neue Musik* [Journal for New Music]. Mainz 1972, pp. 23-34, here: p. 23.

² Earle Brown: *December 1952*. For one or more instruments and/or sound-producing media. In: Earle Brown: *Folio and 4 systems*. New York 1961, no page named.

³ Anestis Logothetis: *Styx*. Composition for any combination of instruments. Cologne 1972.

⁴ Robert Moran: *Four visions*. For flute, harp and string quartet. London 1974.

⁵ Cf. Györgi Ligeti: *Neue Notation – Kommunikationsmittel oder Selbstzweck?* [New notation – medium of communication or self purpose?] In: Ernst Thomas (ed.): *Notation Neuer Musik* [Notation of New Music]. Darmstädter Beiträge zur Neuen Musik IX [Darmstadt's contributions to New Music IX]. Mainz 1965, pp. 35-50, here: p. 40.

inexact and indeterminate. Graphic notation can hence be understood as ambiguous notation¹ and a provocation to improvisation². In most cases, the traditional time axis is, further, non-existent while composers that make use of graphic notation aim rather at replacing traditional notation than at extending it.

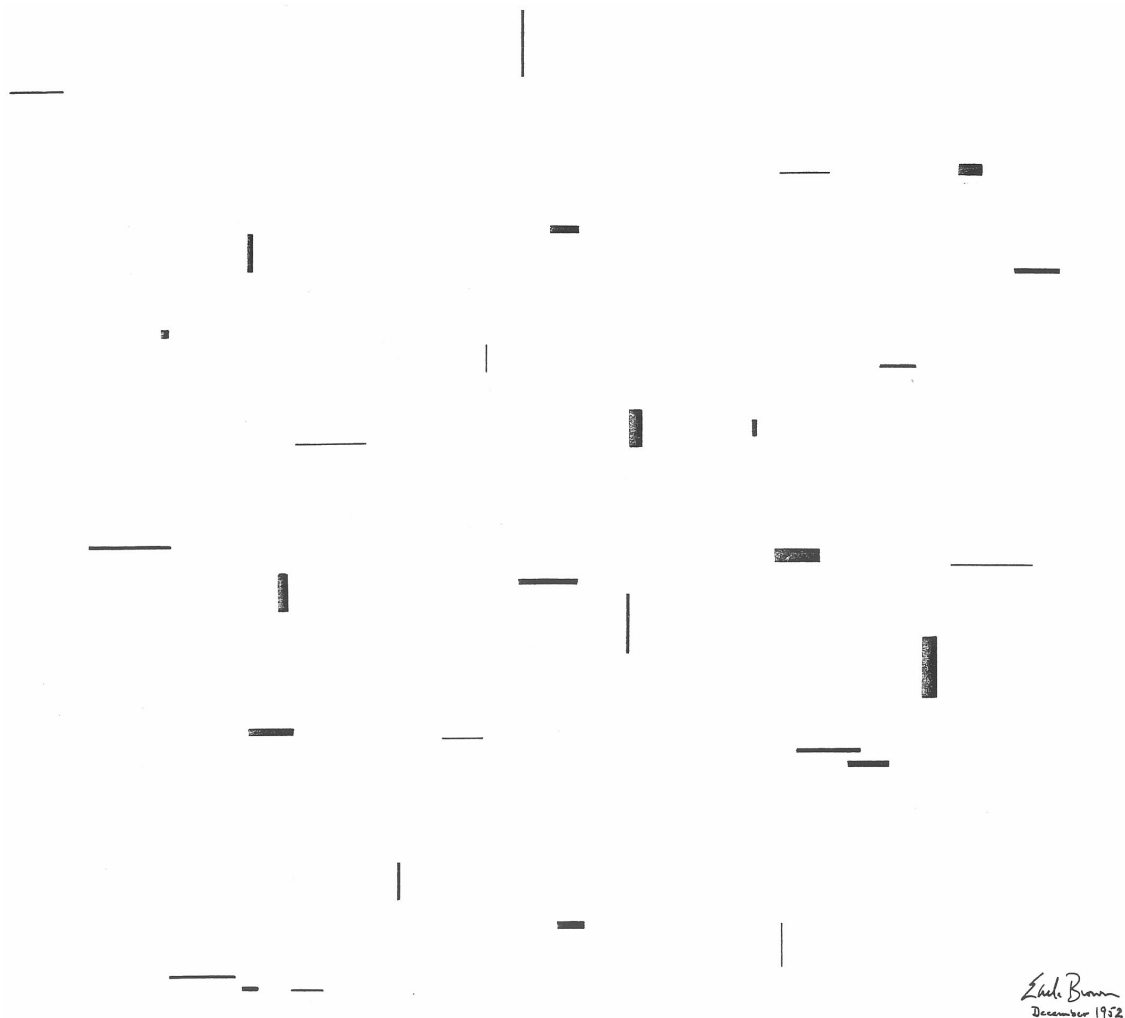

Fig. 2 Brown, December 1952, no page named.

Further, descriptive notation completely abandons the utilisation of a notation system. The action that leads to a sonic result is, in such a case, depicted by writing it down in

¹ Cf. Dahlhaus, *Notation*, p. 30.

² Roman Haubenstock-Ramati: *Notation – Material und Form* [Notation – material and form]. In: Ernst Thomas (ed.): *Notation Neuer Musik* [Notation of New Music]. *Darmstädter Beiträge zur Neuen Musik IX* [Darmstadt's contributions to New Music IX]. Mainz 1965, pp. 51-54, here: p. 52.

the traditional manner¹. An example for such a method of notation is König's electro-acoustic composition *Essay*². It mainly consists of technical instructions presented in the form of a book. The sonic material and its transformation, as well as the organisation of the events in time, are exactly described in the work. However, the score lacks the time axis and the instantaneous comprehension of traditional notation. As shown, graphic notation does not fulfil the first and third criteria because it may be described as approximate and the time axis is often not preserved. Generally, it aims rather at replacing traditional notation than at extending it. Further, descriptive notation does not preserve the time axis and instantaneous comprehension. It is hence opposed to the third criterion.

The exclusion of approximate, qualitative, graphic and descriptive notation leaves four main methods of notation that agree with the postulated criteria. They are called **action notation**, **symbolic notation**, **diagrammatic notation** and **schematic notation**. The first three methods are commonly used in traditional notation. As mentioned, instantaneous comprehension inter alia rests on learnable directions. When these directions do not indicate the resultant sound, but the action leading to it, action notation is utilised. The instruction *sul ponticello* – (bowing) close to the bridge – does not, for instance, describe the sound itself, which consists of higher partials and implies an increase of bowing noise, but tells the string player what kind of action he needs to perform in order to produce it³. However, in order to preserve instantaneous comprehension, the directions need to be limited to a small number of words. Further, the closer they are related to traditional notation, the better do these directions fulfil the third criterion.

¹ Cf Karkoschka, Notation, p. 3.

² Gottfried Michael König: *Essay*. Composition for electronic sounds. Vienna 1960.

³ Cf. Karkoschka, Notation, p. 3.

Moreover, symbolic notation makes use of symbols that depict the performance of particular actions. The symbol for the *Bartók pizzicato* (ϕ), for instance, requests to pluck the string vertically and make it rebound off the fingerboard, producing a percussive effect that complements the fingered tone. Theoretically, any sonic event might be depicted by symbolic notation. However, in order to fulfil the criterion of simplicity, the performers should not be forced to learn a huge number of new symbols while the process of learning new symbols could be facilitated when these are related to the action they are supposed to depict instead of being an abstract representation of it.

Furthermore, traditional notation itself may be regarded as a musical diagram because it is a two-dimensional geometric symbolic representation of sonic events¹: the (horizontal) x-axis represents time in a geometric symbolic way by utilising sequences of note values or rests, respectively, whilst the (vertical) y-axis represents the pitch or frequency (in tempered notation) by means of the factor $^{12}\sqrt{2}$ and with the help of accidental symbols. However, the traditional musical diagram can be modified in order to notate parameters other than pitch. As long as the time axis is preserved extended, or other forms of diagrams, may be used to depict any kind of parameter in accordance with the third criterion.

The fourth method of notation, which implies the utilisation of schemes in order to depict a sonic event, has not been commonly used in traditional notation. However, many examples of schematic notation can be, for instance, found in Kagel's *Staats-theater*². As can be seen in figure 3, Kagel makes use of a simple schematic drawing in

¹ Diagrams are, as Brasseur explains, abstract graphic portrayals of the subject matter they represent. This definition includes any visual formatting device that does not display quantitative data, has simple shapes and is connected by lines, arrows or other visual links. The characteristics of a good diagram was, according to him, elegance, clarity, ease, pattern, simplicity and validity. Moreover, these kinds of visuals are very good at showing actions, processes, events or ideas (cf. Lee Brasseur: *Visualizing technical information. A cultural critique.* New York 2003, p. 71). In fact, a musical diagram may resemble a scatter plot or line chart whilst one of the coordinates is normally time.

² Kagel, Mauricio: *Staats-theater.* Scenic composition. London 1971.

order to explain that a performer is supposed to open a hollow sphere. This process is then depicted in time by means of traditional durations¹.

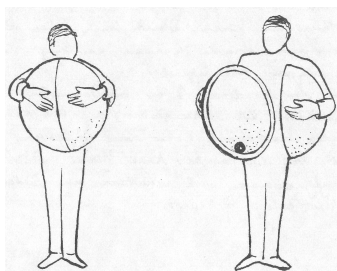

Fig. 3 Kagel, Staatstheater, p. 3 [Repertoire].

Generally, schematic notations need to be as exact and simple as possible in order to fulfil the first and second criteria. Additionally, when schemes become part of a score, they have to be – as in the example – depicted by means of a traditional timeline in order to comply with the third criterion.

1. 4 Context of the thesis

This thesis grapples with instrumentation and specifically with the problems that have evolved by introducing numerous new extended playing techniques in the second half of the 20th century. The utilisation of ‘special instrumental effects’ cannot be reduced to the late 20th century. For instance, the *pizzicato* on string instruments, which is a very conventional playing technique today, was once considered a ‘special effect’². However, in the post-war era numerous “adventurous instrumentalists have been striving to broaden the possibilities which are in their hands”³ and many composers have employed these huge amounts of new techniques in their works. The exchange between composers

¹ Cf. *ibid.*, p. 3 [Repertoire].

² Cf. Ertuğrul Sevsay: *Handbuch der Instrumentationspraxis* [Handbook of instrumentation practice]. Kassel et al. 2005, p. 62.

³ Pierre Boulez: Preface. In: Pascal Gallois. *The techniques of bassoon playing*. Kassel et al. 2009, p. 7, here: p. 7.

and instrumentalists has been of great importance since “in the majority of cases, the composer certainly has imagination, but not practical use of most of the instruments”¹. However, in order to limit the extent of this thesis, it cannot be examined in detail how each unconventional technique was actually discovered and who was involved in this process. Nevertheless, some of the notable performers and ensembles are mentioned here in order to provide a brief insight into the connections between the composers who made use of extended techniques in their pieces and the performers who realised these works, explored the limits of their instruments and/or discovered these techniques.

Among the notable string players are Gidon Kremer and the members of the Arditti String Quartet. For instance, Kremer worked closely with Luigi Nono on composing his work *La lontananza nostalgica utopica futura*² and also premiered it in Berlin³. The Arditti Quartet, founded in 1974 by Irvine Arditti, premiered numerous works, e. g. by John Cage, Luigi Nono, Karlheinz Stockhausen or György Ligeti, and many composers composed pieces especially for this quartet⁴. Among the notable wind players are Roberto Fabbriciani and Ciro Scarponi who frequently collaborated with *Nono*, inter alia on composing his works *Das atmende Klarsein*⁵ and *A Pierre*⁶. Further, Steven Schick can be described as one of the most important modern percussionists. He has commissioned numerous pieces from renowned composers, including Brian Ferneyhough with whom he worked together at the University of California, San Diego⁷.

¹ Ibid., p. 7.

² Luigi Nono: *La lontananza nostalgica utopica futura*. For solo violin, 8 magnetic tapes and 8 to 10 music stands. Milan 1988.

³ Cf. Gidon Kremer: *Obertöne [Overtones]*. 3rd edition. Salzburg and Vienna 1977, pp. 206-214.

⁴ 1999 Ernst von Siemens Musikpreis [1999 Ernst von Siemens Music Prize]. Arditti Quartett [Arditti Quartet]. Edited by the Ernst von Siemens Foundation. Zug 1999, pp. 5f.

⁵ Luigi Nono: *Das atmende Klarsein*. For small chorus, bass flute, live electronics and magnetic tape. Milan 2005, p. IV.

⁶ Luigi Nono: *A Pierre*. *Dell'azzurro silenzio, inquietum*. For contrabass flute in G, contrabass flute in B flat and live-electronics. Final version. No city named [Italy] 1996, p. II.

⁷ Steven Schick: *The percussionist's art. Same bed, different dreams*. Rochester 2006, pp. 90 and 249.

Moreover, among the notable players of plucked instruments are Carlo Salzedo and Leo Brouwer. Already in 1921, Salzedo composed the work *Modern study of the harp*¹, which employs a number of extended techniques, while Leo Brouwer, a Cuban guitarist and composer, developed a number of extended guitar techniques and augmented the possibilities of the guitar as an interpreter and as a composer². Among the notable pianists are David Tudor and Maurizio Pollini. Since Tudor's debut at the Donaueschingen Festival in 1954 and his residency at the Darmstadt International Summer Courses for New Music in 1958, he has functioned as the most catalytic representative of experimentalism in Western Europe³. Tudor collaborated with and has had an impact on the works of many important composers of the 20th century⁴. Pollini is another great pianist whose commitment to the cause of Pierre Boulez and Karlheinz Stockhausen has not wavered and is unparalleled among pianists of his stature⁵. Furthermore, among the notable ensembles are the Ensemble interContemporain, the Ensemble Modern Frankfurt, the ensemble 'die Reihe' and the Ensemble Recherche. The Ensemble interContemporain, founded in 1975 by Pierre Boulez, premiered several works, e. g. by Luciano Berio, Brian Ferneyhough, Iannis Xenakis or Karlheinz Stockhausen⁶. The Ensemble Modern Frankfurt, founded in 1980, is dedicated to performing music from the 20th and 21st centuries. The ensemble worked closely with essential composers,

¹ Carlos Salzedo: *Modern study of the harp*. New York 1921.

² Alain Pâris: *Klassische Musik im 20. Jahrhundert [Classical music in the 20th century]*. 2nd extended, completely revised edition. Munich 1997, p. 106.

³ Cf. Amy C. Beal: *New Music, new allies. American experimental music in West Germany from the zero hour to the reunification*. Berkeley et al. 2006, p. 84.

⁴ Cf. Frank Hilberg: *David Tudors Konzept des 'elektrifizierten Klaviers' und seine Interpretation von John Cages 'Variations II' (1961) [David Tudor's concept of the 'electrified piano' and his interpretation of John Cage's 'Variations II' (1961)]*. Saarbrücken 1996, p. 14.

⁵ Stanley Sadie (ed.): *The new Grove dictionary of music and musicians*, vol. 20. 2nd edition. No city named 2001, pp. 43f.

⁶ Ludwig Finscher (ed.): *Die Musik in Geschichte und Gegenwart [Music in the past and present]. Personenteil [Persons]*. Kassel et al. 2001, pp. 375-378.

such as Karlheinz Stockhausen or Helmut Lachenmann. Moreover, the Ensemble 'die Reihe', founded by Friedrich Cerha et al. in 1958, premiered works by Krzysztof Penderecki and György Ligeti. Finally, the Ensemble Recherche, founded in 1985, is one of the most distinguished ensembles for New Music: with over 400 premieres it has made a substantial contribution to the development of chamber and ensemble music¹.

Furthermore, in order to understand the historical implications of this work, one needs to be aware of the most important developments in the post-war era: after World War II ended, composers started to discover various new possibilities in music. New composition techniques were developed or, respectively, older techniques further developed. Composers, such as Milton Babbitt, Olivier Messiaen, Pierre Boulez, Karlheinz Stockhausen and Henri Pousseur, made use of complex serial techniques² that were derived from the twelve-tone technique as applied by Arnold Schönberg and Anton Webern³. Moreover, in the middle of the 20th century, chance music/aleatoric music⁴ emerged⁵. John Cage was one of the pioneers in using aleatoric methods to compose music and also played an important part in developing open concepts that granted the performers more responsibility concerning the realisation of notated music⁶. Such new methods of notation were, for instance, applied by Stockhausen in his

¹ Cf. Luigi Nono: *Prometeo, tragedia dell'ascolto*. For singers, speakers, chorus, solo strings, solo winds, glasses, orchestral groups and live electronics. Booklet, recording 2003. No city named [Vienna] 2007, p. 68.

² Serialism: a method of composition in which a fixed permutation, or series, of elements is referential, i. e. the handling of those elements in the composition is governed, to some extent and in some manner, by the series.

³ Cf. Mark Delaere (ed.): *Rewriting recent music history. The development of early serialism 1947-1957*. Leuven 2011, p. 9.

⁴ Aleatory: a term applied to music whose composition and/or performance is, to a greater or lesser extent, undetermined by the composer.

⁵ Jongwon Joe and S. Hoon Song: Roland Barthes' 'text' and aleatoric music: is the 'birth of the reader' the birth of the listener? In: *Muzikologija* 2, issue 2. No city named 2002, pp. 263-281, here: p. 263.

⁶ Matthias Hermann: *Weiterentwicklung des Serialismus [Further development of serialism]. Aleatorik [Aleatory]. Reaktionen auf den Serialismus [Reactions to serialism]. Postserielle Konzepte [Post-serial concepts]*. Stuttgart 2002, p. 56.

*Klavierstück XI*¹ (1956). In this piece, he gives the performer the liberty to decide which of the 19 (form) groups he starts with and how he further proceeds from group to group². Scores that make use of graphic notation can be regarded as extreme examples of open concepts that give performers utmost responsibility (see above). Furthermore, new musical material was introduced or, respectively, new methods of manipulating the material were used. In 1943 Pierre Schaeffer founded a research unit for radiophonic art, which was the source for autonomous loudspeaker music. Schaeffer's first *Concert des bruits* [Concert of noises] was broadcast in 1948 by the Radiodiffusion Télévision Française [French Radio and Television Broadcasting] in Paris³. He referred to this music as *musique concrète* [concrete music]. It was based on preexistent, borrowed elements – noises or instrumental sounds – that were organised in an experimental, non-theoretical manner⁴. The sonic material is described as being concrete because it is recorded before the actual realisation of a composition and because it is not notated (and hence not abstract), but stored in a physical (and hence concrete) way on a medium, i. e. magnetic tape⁵. The basic materials for his compositions were not only European, exotic or prepared instruments, but also common noises. Schaeffer made recordings at train stations and factories, as well as recording wind, rain, water or animals⁶. Such sounds were for a long time declared as being ugly and banned from art music. John Cage, in his 1937 manifesto *The future of music – credo*, is one of the earliest

¹ Karlheinz Stockhausen: *Klavierstück XI*. 8th edition. London 1998.

² Cf. Konrad Boehmer: *Zur Theorie der offenen Form in der Neuen Musik* [On the open form theory in New Music]. Darmstadt 1967, pp. 71-73

³ Martin Supper: *Elektroakustische Musik und Computermusik* [Electroacoustic music and Computer Music]. Darmstadt 1997, p. 19.

⁴ Hans Ulrich Humpert: *Elektronische Musik* [Electronic music]. Mainz et al. 1987.

⁵ Cf. Supper, *Musik*, p. 19.

⁶ Cf. Humpert, *Musik*, p. 23 and Pierre Schaeffer: *Musique concrète*. Translated by Josef Häusler. Stuttgart 1974, p. 21 and Rainer Nonnenmann: *Angebot durch Verweigerung* [Offerings by denial]. *Die Ästhetik instrumentalkonkreten Komponierens in Helmut Lachenmanns frühen Orchesterwerken* [The aesthetic of instrumental-concrete composition in Helmut Lachenmann's early orchestral works], Mainz et al. 2000, p. 30.

composers to accept noises as musical material. Moreover, in his early works he had already started to explore new instrumental possibilities as well as all sorts of noises that can be produced by common items¹. Further, in 1948 Louis and Bebe Barron started to manipulate recorded sonic materials by means of tape recorders. They became part of the group Music for Magnetic Tape, founded by John Cage in 1951 in New York, which consisted of Earle Brown, Morton Feldman, David Tudor and Christian Wolff². In Cologne another approach was adopted by a group of composers including Robert Beyer, Herbert Eimert, Karlheinz Stockhausen, Karel Goeyvaerts and Gottfried Michael König. These composers used the studios of the Nordwestdeutscher Rundfunk [North-West German Radio] to create *elektronische Musik* [electronic music]³, which consisted, in its strictest sense and opposed to Schaeffer's *musique concrète*, solely of synthetically produced sonic material and was constructed serially⁴. The first electronic compositions were produced by Beyer and Eimert: *Klang im unbegrenzten Raum* (1951-1952), *Klangstudie I* (1952) and *Klangstudie II* (1952-1953)⁵. Additionally, new performance strategies were introduced. They can be described by the term live-electronics, which refers to instrumental performances that are complemented by playing back pre-recorded sonic material, instrumental performances that are complemented by electronic manipulation, the utilisation of synthesisers, electronic ensembles and/or computer-based, interactive systems. Cage's *Imaginary Landscape No. 1*⁶ (1939) is considered to be one of the earliest live-electronic pieces, while Varèse's *Déserts*⁷

¹ Cf. Hilberg, David, pp. 3-5.

² Supper, Musik, p. 17.

³ Cf. Peter Manning: *Electronic and Computer Music*. Oxford 1985, pp. 43-45.

⁴ Cf. Supper, Musik, p. 22.

⁵ Manning, *Electronic*, p. 45.

⁶ John Cage: *Imaginary landscape no. 1*. For records of constant and variable frequency, large Chinese cymbal and string piano. New York 1960.

⁷ Edgard Varèse: *Déserts*. For 15 instruments, percussion and tape. Milan 2000.

(1949-1954) is a very early example of the playback of pre-recorded sonic material in an instrumental performance¹.

Hence an enormous amount of new possibilities opened up after the Second World War: firstly, new or further developed composition techniques, secondly, new or further developed methods of notation and, thirdly, new or emancipated sonic materials were introduced. In the further course of the century, these possibilities were further refined or (partially) dropped. For instance, Iannis Xenakis refined serialism by introducing stochastic laws into composition and using computers to calculate the organisation of parameters such as pitch, articulation, duration and dynamic level². In contrast, Nono started to use serial techniques in a less strict sense than he still did when constructing *Il canto sospeso*^{3/4}. Moreover, Morton Feldman, one of the pioneers of indeterminate music, changed his concept of notation radically in 1970 and began to notate his music again precisely, if not more precisely than before⁵. Further, Lachenmann, inspired by Schaeffer's *musique concrète*, started to use the term *musique concrète instrumentale* to describe his works in 1970. However, he was not concerned with the recording of sounds or the non-theoretic construction of music, but rather with producing some of the sonic materials utilised by Schaeffer – common noises – by utilising orchestral instruments in an extended way⁶. Moreover, in terms of these materials' treatment,

¹ Martin Supper, *Musik*, p. 13.

² Iannis Xenakis: *Formalized music. Thought and mathematics in composition*. Bloomington and London 1972, pp. 12-21 and 131-154 or Iannis Xenakis: ST/4-1,080262. String quartet. London et al. 1967, no page named [foreword].

³ Luigi Nono: *Il canto sospeso*. For soprano, contralto, and tenor soli, mixed chorus and orchestra. London et al. 1957.

⁴ Cf. Wolfgang Motz: *Konstruktion und Ausdruck [Construction and expression]*. Analytische Betrachtungen zu *Il canto sospeso* (1955/56) von Luigi Nono [Analytical examinations of Luigi Nono's *Il canto sospeso* (1955/56)]. Saarbrücken 1996, p. 8.

⁵ Cf. Morton Feldman: *Slee Lecture*, February 2, 1973. Baird Hall, University at Buffalo, The State University of New York. Transcription by Nicola Walker-Smith. No city named 2001, no page named.

⁶ Cf. Helmut Lachenmann: *Musik als existentielle Erfahrung [Music as existential experience]*. Schriften 1966-1995 [Writings 1966-1995]. Wiesbaden 1996, pp. 149f. and 152.

Lachenmann's approach is opposed to Schaeffer's: in Schaeffer's works everyday sounds are recorded and, despite being manipulated, they can always be associated with their original context. Hence they are, due to their everyday-world-semantics, always linked to reality. In contrast, in Lachenmann's (early) works, the instrumental sounds are not supposed to refer to the everyday world, but merely present the mechanic-energetic conditions of the instrumental sound production¹. Further, he is also opposed to the approach of the *musique concrète* to use a device as an instrument and, for instance, create an *ostinato* figure with a (recorded) jet of tap water or steam whistle, but rather uses instruments as devices².

1.5 Pursued approach

This thesis is concerned with suggesting a common language for unconventional elements of the so-called *musique concrète instrumentale* and hence with the introduction of new or emancipated sonic materials by means of new or further developed methods of notation. This language can theoretically be employed in an old-fashioned way and, hence, in combination with obsolete rhythmic structures or in tonal works, but is also open to serial/aleatoric (or intuitive) construction methods. Moreover, it is not opposed to open concepts in general (e. g. Stockhausen's open form concept in *Klavierstück XI* could be combined with this language), but is, as shown above, distinct to the approach of notating approximate values and extreme examples of open concepts.

In compliance with Lachenmann's approach outlined in *Musik als existentielle Erfahrung*, traditional notation is used whenever possible. However, opposed to his *ad hoc* invention of new signs or symbols, this language is based upon a theoretic

¹ Cf. Nonnenmann, *Angebot*, pp. 32f. and Lachenmann, *Erfahrung*, p. 150.

² Cf. Frank Hilberg: *Geräusche?* [Noises?] In: Ulrich Tadday (ed.): *Helmut Lachenmann*. Munich 2009, pp. 60-75, here: pp. 72f.

reflection of the methods that are introduced with regard to previous methods of notation and the criteria postulated above¹. Most of the extended techniques discussed in this thesis can be used to produce noises, and all techniques are opposed to the traditional verdict that instruments should produce ‘pure’ and clear tones². The notation system introduced in this thesis encourages composers and interpreters to explore the sonic world of noises and non-traditional tones. However, one needs to be aware that, especially when requesting techniques that produce noises, composers cannot control all aspects of the produced sound itself. For instance, in the case of employing percussive effects on the keyboard lid, changing the piano model would have a great impact on the resulting sound, but it is, in most cases, impossible to determine that only a single model should be used. Moreover, this uncontrollable impact on the quality of the sound is greater than distinguishing different spots on the keyboard lid. Nevertheless, by making the player knock on different spots, and not just a single one, he will notice that there are slight nuances between the sound that is produced by knocking on one or the other spot. This is because noises are very complex and subtle sounds. By distinguishing a number of spots on the keyboard lid, the pianist is encouraged to examine the texture of the available lid and the careful listener might get a sense of this subtlety, especially when additionally studying the score (cf. section ‘6. 8 Percussive effects and their notation’). The same is valid when requesting various so-called agents of attack or requesting the player to hit a number of different spots on the head of a bass drum, referred to as ‘points of impact’. The term ‘agent of attack’ is used to describe all sorts of items, including normal mallets, which can be used to attack an instrument (or device). A drumstick is a normal agent of attack, but there are also special, or unusual,

¹ Cf. Lachenmann, *Erfahrung*, p. 151.

² Cf. Nonnenmann, *Angebot*, pp. 21f.

agents of attacks, such as pens, tuning forks or carpet beaters. These items are neither traditional nor common and, therefore, distinguished from normal agents. Further, as in the case of the piano example, changing the model of an agent of attack may have a greater impact on the produced sound than switching between hard, medium and soft bass drum mallets or between a pencil and ballpoint pen (cf. section '4. 1. 1 Special agents of attack and their notation'). Likewise, changing the model of the utilised bass drum may have a greater impact than distinguishing various spots on its head (cf. section '4. 2. 3 The point of impact'). Nonetheless, as in the case of the keyboard lid, it will make the player and careful listener explore the sound-wise nuances of the specific available agents and/or instruments with regard to the approach adopted in the score.

Furthermore, when solely studying scores, it is quite irrelevant if they can be easily read or need to be deciphered and if the utilised methods of notation contain a great amount of so-called instantaneous comprehension or not. This is because the analyst does have a sufficient amount of time to clarify the unclear. However, when performers are supposed to realise a composition, it is more comfortable for them if the score does not need to be deciphered first and contains a great amount of instantaneous comprehension, meaning that they can easily read and play at the same time. In order to guarantee clarity and instantaneous comprehension, utilised directions should not be too long, symbols should be clearly identifiable and drawings unambiguous. When this is the case, the performers needs to manage an easier task as well as they may be more satisfied than if clarity and instantaneous comprehension were not given. However, this is not the only advantage: when producing a composition of this kind and recording the work, the recipient may more easily read the score and listen to the music at the same time. Since I consider this one of the most beautiful experiences that music is able to generate, I am deeply concerned about producing and facilitating the possibility of such

an experience. Therefore, all directions, symbols and drawings introduced in this work are intended to be very clear and plain. This aesthetical preference results, for instance, in all utilised drawings resembling technical drawings. Examples of this are the drawing used to explain a violincello/contrabass technique where the player is supposed to place the bow in the space between the fingerboard and the body and scratch the back of the fingerboard (cf. figure 20 in the chapter on string instruments) or the depiction of the interior of a grand piano (cf. figure 309 in the chapter on keyboard instruments). The same is valid for new methods of notation that had to be introduced in order to depict special effects or certain sounds with indefinite pitch. One important new method is referred to in this thesis as the transposition or ‘transposition’ system. It is first introduced in section ‘3. 3. 1 The trumpet embouchure’ and used to describe any kind of transposition that cannot be described by means of the pitch-based notation system, either because the resulting pitch is unclear or because sounds with indefinite pitch are ‘transposed’. In the case of the latter, the term transposition is in inverted commas because it actually only refers to altering the pitch. However, the effect is similar when ‘transposing’ sounds with indefinite pitch because either brighter (‘higher’) or darker (‘lower’) noises (‘pitches’) are produced. An example of such a ‘transposition’ is the technique presented in section ‘4. 3 ‘Pitch’ bending – the extended *glissando*’; for instance, on membranophones (with indefinite pitch), the ‘pitch’ may be raised by controlled hand or elbow pressure. Moreover, the transposition/‘transposition’ system itself can be thought of as a two-dimensional coordinate system. The x-axis always represents the time by means of rests. Rests, and not notes, are used because the sound is, in the case of such transpositions/‘transpositions’, transformed and no additional sound is produced (which would be suggested by notes). The y-axis of this system always depicts the degree of transposition/‘transposition’. The positive y-axis represents

upward transpositions/‘transpositions’ (higher or brighter sounds) and the negative y-axis downward transpositions/‘transpositions’ (lower or darker sounds). Dots (◊◆) are then used to depict the transposition/‘transposition’ in time, while white dots are normally used. To give an example of a transposition: when one white dot is placed on position (0/+2) and another on position (crotchet/-2), a *glissando* from transposition level +2 to transposition level -2 is supposed to be performed for the duration of a crotchet. Since the maximum amount of upward and downward transposition levels is given (e. g. +/-6), the player estimates to what degrees the transposition levels +2 and -2 are referring to. Moreover, a special case is exemplified in figure 130 in the chapter on wind instruments. Here a wind player is supposed to produce four distinct crotchets with the same fingering, but each tone is transposed in another way by changing the lip tension and/or shape of the mouth. The first crotchet is constantly transposed to level -2, the second to level +4, the third to level +2 etc. Because using only white note heads would lead to an ambiguous notation, additional black note heads are introduced. By doing so, it is clearly depicted that constant transpositions are requested. If this was not the case, the player would not know whether to transpose the crotchets constantly or to play a *glissando* from -2 to +4 for the duration of crotchet, followed by a *glissando* from -2 to +4 (or +2) for the duration of another crotchet and a *glissando* from +2 (or +4) to the next value etc.

Further, another special notation system used in this thesis is referred to as the string clef system and introduced in section ‘2. 4. 2 Fingering in between fingerboard and bridge and its notation’. This system is, however, more common than the transposition system. It can be used when sounds with indefinite pitch are supposed to be produced on the strings of a string instrument or a guitar and simply describes on which string a particular technique is executed. The technique itself is then described by means of the

utilised note head. For instance, playing behind the bridge is requested by means of the string clef system and x-shaped note heads. Thus when an x-shaped note head is placed in the space between two lines that refers to the G-string of a violin, the violinist is requested to play behind the bridge on the G-string (cf. section ‘2. 4. 4 Playing behind the bridge’).

Finally, instrumental preparations play an important role in producing new sonic materials by means of traditional instruments. As shown in chapter ‘2. 8 Preparing the instrument and its notation’, most preparations can be easily notated by explaining preparations in the foreword of a work. However, when preparing an instrument and, by doing so, potentially creating a new, modified instrument, new playing techniques may at the same time be created. Since the prescribed extent of this work is clearly limited, the possibilities of preparing traditional instruments are nearly limitless and – because they are more common and ‘natural’ – the focus lies on unconventional extended techniques of unprepared instruments, unconventional extended techniques of prepared instruments cannot be discussed in detail. Likewise, since the prescribed extent of this thesis is clearly limited, not every single instrument of the Western orchestral apparatus can be discussed. For instance, the electric guitar/bass as well as the harpsichord and organ are disregarded here in order to limit the scope of the work. In serious music these instruments are rarer than the instruments examined in this thesis and, therefore, omitted. Additionally, vocal techniques cannot be considered. However, they are, due to their importance for the orchestral apparatus, part of a followup work. This followup work also includes electroacoustic techniques. Additionally, it is desirable to further augment the work by suggesting methods of notation for the extended techniques of the rarer, but still important, (prepared and unprepared) instruments described above as well as to scrutinise Asian instruments.

This thesis is divided into theoretical and practical parts. In the theoretical part, the unconventional elements of most string, wind, percussion, plucked and keyboard instruments are examined, and previous approaches towards their notation are presented and discussed, as well as suggestions for their notation being introduced. The practical part then displays compositional works in order to explain how the developments can be applied. It needs to be noted that the developments presented in this work are regarded as suggestions that aim to fulfil the defined criteria. They do not claim to be a universal method of notation, but can instead rather be understood as an initial approach towards the coherent depiction of the unconventional that may be further elaborated, adapted to the needs of the composer who makes use of them or be inspired by the analyses of the techniques.

1.6 Summary

Most of the extended instrumental playing techniques are still deprived of a conventional method of notation. In order to facilitate the utilisation of these elements, this thesis aims to develop a coherent and consistent notation system. To coherently depict all playing techniques subject to this work, three criteria are defined. They postulate all suggested methods of notation being as exact as possible and as simple as possible. Moreover, they may not be contradictory to traditional notation, but should instead extend and be closely related to it. Further, in order to guarantee that the additions are legitimate and consistent, they need to be compatible with, and distinct from, all other signs of the system. By implementing these criteria, some methods of notation are rejected because they cannot be reconciled with them. These methods are approximate notation, qualitative notation, graphic notation and descriptive notation. This exclusion leaves four other methods of notation that can be utilised in accordance with the three

criteria. They are referred to as action notation, symbolic notation, diagrammatic notation and schematic notation.

Generally, this thesis grapples with instrumentation and specifically mostly with the unconventional playing techniques developed after World War II by numerous essential composers and/or instrumentalists. The aim of the work is to suggest a common language for the unconventional elements of the *musique concrète instrumentale* described by Lachenmann. The language can be combined with traditional and progressive composition concepts, but is rather opposed to the idea of notating approximate values and extreme examples of open concepts. Most of the extended techniques discussed in this work can be used to produce noises, and all techniques cannot be used to produce ‘pure’ and clear tones. It encourages composers and interpreters to explore the sonic world of noises and non-traditional tones. When doing so, one needs to be aware that it is not always possible to control the quality of the sound itself. However, the system rather stimulates the examination of the subtlety of noises and the textures of sound producers. Another main characteristic is the focus on ensuring instantaneous comprehension because it facilitates the performance of extended techniques and because it enables the recipient to easily read the score and simultaneously listen to the music it depicts. Therefore, all directions, symbols and drawings introduced in this work are intended to be very clear and plain.

Since the extent of this thesis is limited, instrumental preparations that lead to new playing techniques cannot be examined in detail, and chapters on some instruments also had to be omitted, e. g. the electrical guitar/bass, harpsichord, organ and vocal techniques are not discussed. The thesis is divided into theoretical and practical parts. In the theoretical part, a notation system for unconventional elements of most string, wind,

percussion, plucked and keyboard instruments is developed. The practical part then displays compositions that employ the notation system.

2. THE TECHNIQUES OF STRING INSTRUMENTS

String instruments are considered here to be a homogeneous group¹. The extended playing techniques demonstrated in this chapter only vary slightly from instrument to instrument. Therefore, most methods of depiction can be easily transferred from, for instance, a violin to a contrabass and are explained here in a general way. In the case of a particular playing technique being limited to some of the four instruments, it is outlined which string instruments can be used to perform the technique. In order to limit the extent of the work, this chapter solely focuses on the violin, viola, violincello and contrabass. All historic string instruments, such as the rebab, the viola de braccio or the lira de gamba are disregarded here. The harp and guitar are discussed in the chapter on plucked instruments.

As mentioned in the introduction, in notated instrumental music problems evolve when a conventional method of depiction has not been established for a particular playing technique. There are conventions for notating such elements as tones, most harmonics or *glissandi*. Again other aspects of instrumental music, such as the instrumental production of most noises, can quite clearly be determined as unconventional due to that either these sounds have been used seldom or their method of notation varies strongly from composer to composer. Whether a conventional method of depiction exists for a particular playing technique, can be determined by comparing the methods utilised by the essential composers and referring to the handbooks that grapple with instrumentation. When no adequate examples for the notation of a particular effect may be presented, the suggested method of notation needs to be developed without a previous discussion. However, such cases are generally rare.

¹ Cf. Sevsay, Handbuch, p. 27.

In the case of string instruments, the notation of the *vibrato* and trill, stops, clusters (cf. section ‘6. 6. 1 Clusters’), the basic *pizzicato* and *Bartók pizzicato*, the basic *glissando*, the common bowing positions and techniques, the application of mutes, the production of harmonics and the *scordatura* (previous to, or simultaneous with, playing) are regarded here as conventional¹. Their notation can be accessed through the essential handbooks on instrumentation whilst most composers use the method of depiction that can be found there. Whereas, the main unconventional elements of sound production presented in this chapter are extended *pizzicato* techniques, extended *glissando* techniques, extended bowing techniques, extended playing positions on the string, playing exceptional spots, extended stopping techniques, percussive effects and preparing the instrument. Concerning the dynamic level of these articulations, indications are – as far as possible – presented when the execution of the action is, in terms of the loudness, limited. Further, the notation of microtones is ambiguous. This is because although microtones have been used frequently in the 20th century, no main method of depiction has been established. In most cases accidentals, derived from the traditional accidentals, are employed². However, an extensive discussion of this topic is, in this thesis, dismissed.

¹ Cf. Sevsay, Handbuch, pp. 27-86.

² Cf. Brian Ferneyhough: *Terrain*. Solo violin and chamber ensemble. London et al. 1993, p. 3, Luigi Nono: *Framente-Stille*, an Diotima. For string quartet. Milan 1980, no page named [foreword] or Iannis Xenakis: *Eonta*. London et al. 1967, no page named [foreword].

2. 1 Extended *pizzicato* techniques and their notation

Besides the basic *pizzicato* and the *Bartók pizzicato*, there are a number of extended plucking techniques that are more or less notated in a standardised manner. One of them is the performance of a ***pizzicato with the left hand***. This technique is either notated by using a plus sign (+)¹ whilst sometimes the addition left or left hand (abbreviated L. H. or LH) is given² or – as employed by Kagel in *Streichquartett IIII*³ – by giving the direction *LH: pizz.*⁴.

The *pizzicato* with the left hand is a variation of the basic *pizzicato*, which is conventionally requested by means of a direction. When depicting it by means of a plus sign, a new symbol is introduced in order to merely request the utilisation of the left hand instead of the right. However, it would be simpler to only present a variation of the original method of notation. Therefore, it is preferred here to depict the *pizzicato* with the left hand similarly to the original articulation, rather than by introducing a new symbol. It is hence suggested employing the direction *LH: pizz.* or the Italian variants *mano sinistra: pizz.* or *pizz. (mano sinistra)*, abbreviated *m. s.*, in order to notate it. When doing so, this technique is depicted in close relation to traditional notation. Nevertheless, since the plus sign is a widely utilised method⁵, and performers are hence used to it, it might also be desirable to employ it. For this reason, the plus sign is regarded here as an alternative to requesting the left-hand *pizzicato* by means of direction.

¹ Cf. Sevsay, Handbuch, p. 63 and Stone, Notation, p. 313.

² Cf. Heinz Holliger: Duo II. For violin and violincello. Mainz et al. 2005, p. 11 or Beat Furrer: Spur. For string quartet and piano. Kassel 1998, no page named [foreword].

³ Mauricio Kagel: Streichquartett I/II. London 1974.

⁴ Cf. *ibid.*, p. 12.

⁵ Cf. its utilisation in Luciano Berio: Sequenza VIII. For violin alone. Milan 1977, p. 11.

Another simple augmentation of the basic *pizzicato* articulation is achieved by involving the fingernail when plucking the string. This technique is usually requested by means of a fingernail symbol. Lachenmann, in *Staub*¹, makes use of such a symbol to depict the **fingernail pizzicato**:

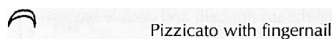

Pizzicato with fingernail

Fig. 4 Lachenmann, *Staub*, no page named [foreword].

Alternatively, the fingernail symbol may be drawn the other way round². However, since it is not as common as, for instance, the symbolic representation of the *Bartók pizzicato* and may also be utilised in combination with other articulations that involve the fingernails, it should be complemented by the direction *pizzicato*. Moreover, a **pizzicato tremolo** may also be requested. It can be depicted by combining the common *pizzicato* and *tremolo* notation while additionally mentioning the fingers the instrumentalist is supposed to utilise in the same way as on the piano³, e. g. 1, 2 or 1, 2, 3⁴.

Furthermore, it is in some compositions required to pluck the string with a pick instead of with the fingers. In *Duo II* Holliger requests such a **plectrum pizzicato** by giving the direction *pizzicato* and presenting a drawing of the plectrum:



Fig. 5 Holliger, *Duo II*, p. 11.

¹ Helmut Lachenmann: *Staub*. For orchestra. Wiesbaden et al. 1997.

² Stone, *Notation*, p. 313.

³ Cf. Sevsay, *Handbuch*, p. 65.

⁴ 0 = thumb, 1 = index finger, 2 = middle finger, 3 = ring finger, 4 = little finger.

The displayed method of notation is related to the depiction of the fingernail *pizzicato*, may be easily comprehended and is often employed. Therefore, it is recommended here being used for the plectrum *pizzicato*. A variant is to hold the violin or viola like a mandolin when plucking it with the plectrum, which is normally requested by the direction *pizzicato al mandolino*¹.

However, when items other than a plectrum are utilised for the performance of a *pizzicato*, no conventional method of notation has been established. The most common item that is used aside from a pick is the screw or nut of the bow. As can be seen in figure 6, in *Zinctum*² Cervetti requests such a **bow-screw pizzicato** by giving the direction *pizzicato* with the nut in a footnote³.

Fig. 6 Cervetti, *Zinctum*, p. 13.

Moreover, in *Toccatina*⁴ Lachenmann depicts a technique referred to as the bow-screw *pizzicato* by means of note heads shaped similarly to the symbolic representation of the *Bartók pizzicato*. However, he explains that the articulation is not performed in the same way as a *pizzicato*, but the player is supposed to hit the fingerboard and string⁵.

¹ Cf. Sevsay, *Handbuch*, p. 65.

² Sergio Cervetti: *Zinctum*. For string quartet. Celle 1969.

³ As apparent from figure 6, two or three tones are supposed to be plucked simultaneously by each player. However, since such an action is impossible to be performed, presumably an *arpeggio* symbol is missing.

⁴ Helmut Lachenmann: *Toccatina*. Study for violin alone. Wiesbaden et al. 2006.

⁵ Cf. *ibid.*, no page named [Appendix].

Therefore, this way of producing sound is discussed in section ‘2. 3. 2 Extended *battuto* and *tratto* techniques and their notation’.

When requesting a *pizzicato* that is performed with the screw of the bow, a method of notation similar to the one employed by Cervetti may be used as it fulfils the requirements of simplicity and exactness. However, in order to achieve a greater degree of instantaneous comprehension, it may be more appropriate to notate the direction (bow-)screw *pizzicato/pizzicato della vite*, over the the note instead of in a footnote or to depict the screw of the bow by a symbol:

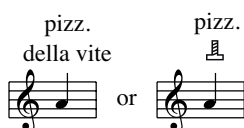

Fig. 7 The bow-screw *pizzicato*.

If any other item, e. g. a nail file, pencil or metal rod, is supposed to be used for the production of a *pizzicato*¹ and hence a so-called *pizzicato with items* is employed, its notation can be achieved similarly to the method of depiction displayed in figure 5 and 7 (also cf. figure 11). However, it needs to be noted that a graphic depiction of the item contains, in most cases, a greater degree of instantaneous comprehension.

Further, there is a *pizzicato* variant that may be referred to as the **lateral Bartók pizzicato**. When requested, the player is supposed to pull the lowest string to the side instead of upwards. When doing so, the string bounces back on the fingerboard and may even hit its adjacent string. The articulation sounds best on violincellos and contrabasses². Sevsay suggests that this technique should be depicted by means of a previously defined symbol or verbal explanation, but does not mention any examples.

¹ Cf. Sevsay, Handbuch, p. 66.

² Ibid., p. 66.

As this articulation is closely related to the more common *Bartók pizzicato*, it can be, however, easily depicted by means of a variation of the symbol used for its notation (⊖) and common note heads that determine which string is supposed to be plucked (the C-string in the case of the violincello and the E-string in the case of the contrabass). Moreover, Sevsay mentions another technique called the pinch-*pizzicato*, which refers to the string being plucked by two fingers. However, because the sound-wise result is not very different from the common way of performing a *pizzicato*, this technique is neglected here and rather regarded as a means of expression. Further, three other techniques that are related to performing the *pizzicato* articulation – *pizzicato* behind the bridge, *pizzicato* in the pegbox and the buzz-*pizzicato* – are discussed in sections ‘2. 4 Extended playing positions on the string’, ‘2. 5 Playing exceptional spots’ and ‘2. 6 Extended stopping techniques’.

2. 2 Extended *glissando* techniques

The basic *glissando* (notation: *gliss.* and a line) is regarded here as to include *pizzicato glissandi*, chordal *glissandi*, harmonic *glissandi*, microtonal *glissandi* etc.¹ whilst the unconventional *glissando* techniques are considered here to be the performance of a **harmonic-*glissando* without bowing** and the **bow-*glissando***.

2. 2. 1 The harmonic-*glissando* without bowing and its notation

Lachenmann, in *Pression*², makes excessive use of the harmonic-*glissando* without bowing. He explains that the cellist is supposed to use the tips of his fingers to slide – quasi *flageolet* – up and down on the string. In order to depict this motion,

¹ Cf. *ibid.*, pp. 59f.

² Helmut Lachenmann: *Pression*. For one cellist. Cologne 1972.

Lachenmann utilises a ‘bridge clef’. This special clef is in his compositions employed “when not the pitch but the place on the surface of the instrument (...) is indicated”¹. The motion the player is required to perform is – as apparent from figure 8 – represented by a line. Moreover, the traditional timeline is replaced by division lines whilst a “division line represents a quarter-note value”². In the example the cellist plays on the bridge (for this technique cf. section ‘2. 4 Extended playing positions on the string’) and simultaneously moves the tip of one finger, after the duration of a minim and two triplet quavers, initially on string I [I. Saite] up and down. When bowing on the bridge, stopping does not modify the sound production by the bow. Therefore, two distinct sounds can be perceived, the bowing noise and the sliding noise. When the player is supposed to slide on more than one string, additional lines are utilised. In the end of the example the cellist is supposed to slide on string I and II.

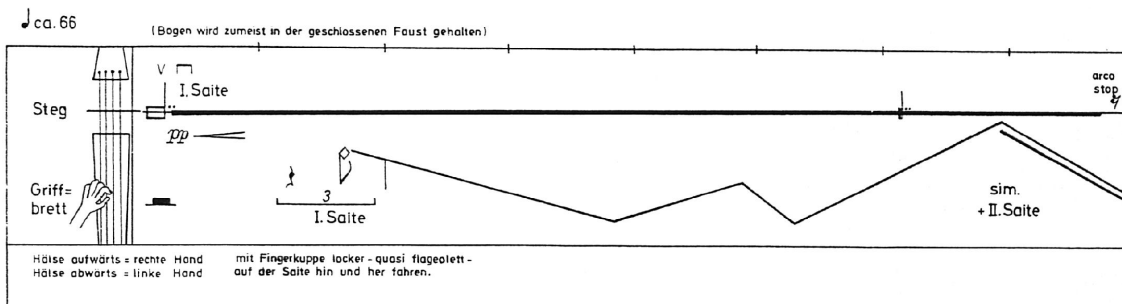

Fig. 8 Lachenmann, *Pression*, p. 2.

However, Lachenmann’s approach does not comply with the first and third premises: both the duration and the length of the *glissando* are only depicted in an approximate way whilst the traditional timeline is dismissed. The action Lachenmann requests is, however, simply a *glissando* that involves harmonic fingering and is performed without using the bow. Hence it can be depicted in the same way as, for instance, a common

¹ Lachenmann, *Toccatina*, no page named [appendix].

² Lachenmann, *Pression*, p. 1.

harmonic-*glissando* when determining that the player is, in this case, not supposed to bow. Because the exact duration could then be notated by means of common note heads (as it is partially done in *Pression*) and the length of the *glissando* be determined more accurately by means of pitch-based notation, the articulation may be requested in a more exact and even simpler manner as well as in closer relation to traditional notation.

Therefore, the harmonic-*glissando* without bowing is suggested here being requested by means of pitch-based notation. As apparent from figure 9, diamond-shaped note heads are used for the depiction of the motion (also cf. section ‘2. 6. 2 Exact muting stops and their notation’). This is because these note heads are also used for the notation of artificial harmonics and certain natural harmonics. The direction *senza arco* (which is related to the direction *arco* that requests normal bowing) determines that the bow is not utilised. Hence when performing this articulation only the scratching noise that is produced by the fingers sliding on the strings can be heard. Moreover, the *glissando* is – in order to achieve a greater clearness and enable the depiction of *glissando* motions that do not involve changes in pitch (see below) – requested here by means of an arrow and not in the traditional manner. Alternatively, the common method of depiction may be restored.

In figure 9 a cellist is supposed to perform a continuous harmonic-*glissando* without bowing. The starting point is the $h/B3$ on the A-string. For the duration of a dotted crotchet the player is required to perform a motion to $c^2/C5$, followed by a motion to e^b1/E^b4 , which is performed for the duration of a crotchet. Subsequently, a motion to $f^2/F5$ is executed for the duration of a crotchet. When this position is reached, the player starts sliding on the A- and D-string simultaneously: from $b^1 - f^2/B^b4 - F5$ to $g^1 - d^2/G4 - D5$ for the duration of a quaver and finally to $c^{\#2} - a^b2/C^{\#5} - A^b5$ for the duration of

another quaver. The demisemiquaver is applied pro forma since the sound production actually ends at this point.

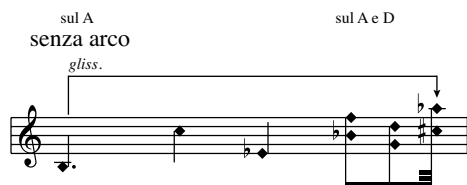

Fig. 9 The harmonic-*glissando* without bowing.

This articulation can be only performed with a very low dynamic level. Moreover, it needs to be noted that the interval of the ‘harmonic chords’ is constantly a fifth. Especially when more than two fingers are involved, this interval (or, in the case of the contrabass, a fourth) should be chosen in order to facilitate the performance of this articulation. This is because when doing so, all fingertips are directly adjacent to each other.

A variant of this articulation is to perform the motion directly on the fingerboard and hence in between the strings. In this case, the player is supposed to **scratch the fingerboard**. This technique is notated here in the same way as the harmonic-*glissando* without bowing. In order to outline that the action is, however, supposed to be executed directly on the fingerboard, the additional direction *il tastò* (the fingerboard) is given. The notes hence depict in this context fingerboard positions.

As can be seen in figure 10, the cellist is supposed to place three fingers in between all four strings (*tra A, D, G e C*) and execute a single motion from the position $a^b - e^b - b^1 - f^2/A^b3 - E^b4 - B^b4 - F5$ to $h - f^\sharp - c^\sharp - a^b2/B3 - F^\sharp4 - C^\sharp5 - A^b5$ for the duration of a crotchet (the demisemiquaver is again applied pro forma). This articulation may be performed with a higher dynamic level than the harmonic-*glissando*.



Fig. 10 Scratching over the fingerboard.

Another variant is to perform a **harmonic-glissando with items**, e. g. a sponge, bottleneck, pencil etc. These items can be depicted in the same way as they are in the case of the *pizzicato* with items and hence by means of a drawing. In the example presented in figure 11, the cellist is supposed to use the rough side of a sponge in order to slide on all four strings. The dynamic level of such an articulation is normally low, but varies from item to item. Moreover, when using, for instance, a bottleneck, simultaneous bowing or plucking the string would lead to a clearly perceivable *glissando* sound while the notes then depict the pitch that is produced. In this case, the direction *senza arco* needs to be replaced by directions *arco* or *pizzicato* and – if appropriate – common note heads with small circles above them be used.

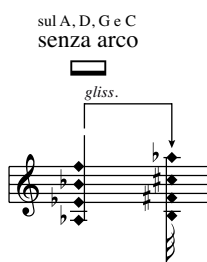

Fig. 11 The harmonic-*glissando* with a sponge.

2. 2. 2 The bow-*glissando*

The extended *glissando* articulations displayed in the previous section are related to a bowing technique that may be referred to as bow-*glissando*, elliptic bowing or the

rotating bow. When this technique is applied, the player is supposed to move the bow not only from the left to the right or right to the left (here designated as horizontal), but also up and down/away from and towards the body (here designated as vertical). This technique has been employed in various compositions and is at most times limited to the three common bowing positions. Further, more seldom utilisations of the bow-*glissando* are to make the player slide the bow on the fingerboard or to solely request a vertical shift, which does not involve any horizontal motion.

2. 2. 2. 1 Previous methods of notation

In Dittrich's *Streichquartett III*¹ all four strings move the bow simultaneously from *sul tasto* to *ordinario* for the duration of a dotted semiquaver and back to *sul tasto* for the duration of another dotted semiquaver. This vertical motion is notated by connecting the bowing position with arrows:

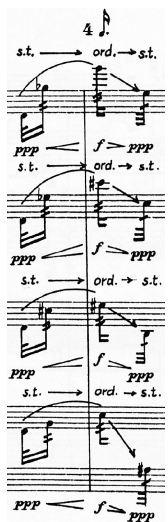

Fig. 12 Dittrich, *Streichquartett III*, p. 85.

¹ Paul-Heinz Dittrich: *Streichquartett III*. Nacht-Musik. Wiesbaden et al. 1995.

Moreover, in *Séquences*¹ Haubenstock-Ramati uses a similar method of depiction in order to make a violinist constantly change the bowing between the indicated areas². In the example presented in figure 13, the player at first repetitively moves the bow between the positions *sul tasto* and *ordinario*. Then he is supposed to play only on the *ordinario* position, before moving the bow from *sul tasto* to *ordinario* to *sul ponticello* to *ordinario* etc.

Fig. 13 Haubenstock-Ramati, *Séquences*, p. 27.

Further, in *Gran torso*³ Lachenmann makes augmented use of the vertical bowing motion. He depicts this articulation by again employing a bridge clef. Additionally, he introduces drawings that request various complex motions, such as an irregular motion in the form of an ‘eight’, an irregular circular motion, an oblique motion or a vertical motion⁴. In the example presented in figure 14, a violinist is supposed to perform a bow-*glissando* in between the *sul ponticello* [Steg] position and a fingered chord. The action starts on the G-string (III) and is then translocated to the D-string (II). Two drawings are additionally employed. The first one requests an irregular circular motion

¹ Roman Haubenstock-Ramati: *Séquences*. Music for violin and orchestra. London 1961.

² Cf. Howard Risatti: *New music vocabulary. A guide to notational signs for contemporary music*. Chicago and London 1975, p. 78.

³ Helmut Lachenmann: *Gran torso*. Music for string quartet. Wiesbaden 1972.

⁴ Cf. *ibid.*, no page named [foreword].

and the second one an irregular motion in the form of an eight¹. The plus sign expresses that “the indicated direction does not annul the previous motion, but increases it”². When these drawings occur, the motion seems to involve all four strings.

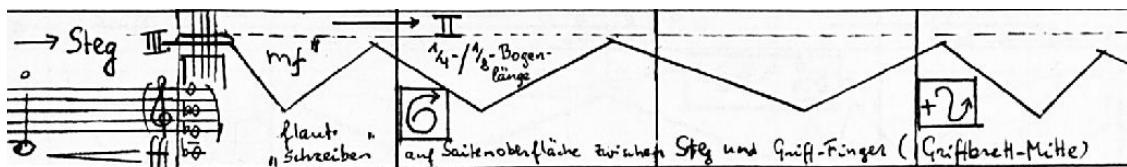

Fig. 14 Lachenmann, Torso, p. 3.

Lachenmann explains that normally the “shifts of the bow on the surface of the string are oblique, that is, they always contain an upbow or downbow motion”³ whilst “[v]ertical shifts of the bow at an angle of 90° to the usual horizontal motion occur only where an arrow pointed upwards or downwards is drawn into the first note tail of (..) a passage”⁴:

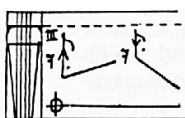

Fig. 15 Lachenmann, Torso, no page named [foreword].

Further, Dittrich, in his *Streichquartett III*, also employs presumably a solely vertical motion⁵ by introducing a special note head that requests to wipe over the string with the

¹ Cf. *ibid.*, no page named [foreword].

² *Ibid.*, no page named [foreword].

³ *Ibid.*, no page named [foreword].

⁴ *Ibid.*, no page named [foreword].

⁵ Dittrich does not clearly outline if this motion is complemented by horizontal bowing. But since the articulation only occurs in combination with a low dynamic level (cf. Dittrich, *Streichquartett III*, pp. 34f.), it is assumed here that solely vertical bowing is supposed to be performed.

bow¹. The articulation is always performed simultaneously by all four instruments on string IV while the extent of the motion is not determined²:



Fig. 16 Dittrich, Streichquartett III, p. 34.

2. 2. 2. 2 Discussion

Dittrich's approach (cf. figure 12) may be described as simple and exact. However, it does not comply with the third criterion: the gradual change of the bowing position is regarded here as a *glissando* because the bow travels on the string in a similar way as the fingers do, e. g. in the case of the harmonic-*glissando*. Therefore, it is preferred to depict a change in the bowing position by means of requesting a *glissando* between these. When doing so, the technique is requested in close relation to traditional notation. The same applies to Haubenstock-Ramati's method of notating a continuous switch between two common bowing positions (cf. figure 13). Actually, this action may be referred to as a trill-*glissando* because the bow is repetitively moved between the positions *sul tasto* and *ordinario*. It could hence be notated by combining the method of notation for trills and *glissandi*. Further, his approach towards the depiction of such a trill-*glissando* between all three common bowing positions may be described as

¹ Dittrich, Streichquartett III, p. 2.

² Cf. *ibid.*, pp. 34f.

containing redundant elements. This is because there is no need to mention that the bow passes the ordinary bowing position when travelling from *sul tasto* to *sul ponticello* and the other way round. Additionally, both methods need to be augmented when the bow is supposed to travel further down the fingerboard.

Lachenmann depicts such an extended bow-*glissando* by means of the bridge clef (cf. figure 14). However, since the motions, as mentioned, resemble a harmonic-*glissando*, it may be, in this case, also stated that there is no need for introducing a special clef in order to notate them. Instead, they can be depicted in the same way as the harmonic-*glissando* with items (cf. figure 11) and hence by means of the pitch-based notation system. Further, with regard to the vertical shifts that do not involve any horizontal motion, another method of notation needs to be developed. This is because Lachenmann's method of adding symbols to the note tail (cf. figure 15) might lead to confusion when semibreves are employed and Dittrich's approach towards the notation of such a wiping (cf. figure 16) is inexact – because he does not outline whether the articulation involves horizontal bowing or not and the extent of the bow-*glissando* is not determined.

2.2.2.3 Suggestion for the notation of the bow-*glissando*

Thus vertical motions of the bow are depicted here by means of the *glissando* notation. In order to outline that the bow (and not the hand) travels on the string, the additional direction *glissando d'arco* is given. In the example presented in figure 17, the method of notation for the bow-*glissando* on the common bowing positions is displayed. Here a violinist is supposed to bow a $c^1/C4$ whilst moving the bow from *sul ponticello* to *sul tasto* for the duration of a dotted crotchet and to *ordinario* for the duration of a quaver. After a crotchet rest a trill-*glissando* between *sul tasto* and *sul ponticello* is performed

for the duration of a minim. During this second bow-*glissando* the player fingers a $g^1/G4$. In the case of combining the trill-*glissando* of the bow with a normal trill(-*glissando*), an additional trill(-*glissando*) symbol would have to be used and placed below the one for the bow.



Fig. 17 The bow-*glissando* on the common positions.

Moreover, when the bow is supposed to leave the common bowing positions and slide on the fingerboard, an additional notation system needs to be used. This second system is placed above the one that depicts the stops. As can be seen in figure 18, the violinist is supposed to finger the same tones as in the previous example, but this time moves the bow from *sul ponticello* to the position $a^1/A4$ on the fingerboard for the duration of a dotted crotchet and subsequently performs a trill-*glissando* with $h^1/B4$ (double sharp) for the duration of a quaver. After a crotchet rest the player starts bowing the D-string on position $a^1/A4$ and hence close to the fingered $g^1/G4$. The bow is then moved to the normal position for the duration of a dotted crotchet, which is subsequently bowed for the duration of a quaver.

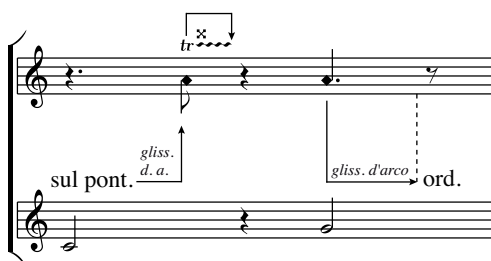

Fig. 18 The extended bow-*glissando*.

Diamond-shaped note heads are employed here because the bow is – as in the case of the harmonic fingering – attached to the string, but does not depress it. It needs to be noted that the further the bow travels down the fingerboard, the more difficult it becomes for the player to bow one string only. This inexactness of performance might result in additional strings being bowed (especially when fingering tones on the middle strings). Further, when, for instance, two strings are supposed to be bowed simultaneously, two notes need to be employed. In the case of their interval being a fifth (or, in the case of the contrabass, a fourth), the bow is aligned at right angles to the string. When changing this interval, the alignment of the bow is altered. Such an alteration may also be performed during the performance of the *bow-glissando*. When sliding onto the fingerboard, it is possible to make the player bow more than two strings at the same time. Additionally, the introduced method of notation may be used to request the player to bow on a lower position than the tone he fingers, i. e. closer to the pegbox¹. Alternatively, the additional notation system could also be used to depict the duration of the *bow-glissandi* on the common bowing positions independently (cf. figure 260 in the chapter on plucked instruments). When using an additional system, it could be designated as ‘right hand’ or ‘bow’ in order to clearly distinguish it from the left-hand system.

A variant of this motion is, as mentioned, to perform a vertical shift without any horizontal motion. Its notation is achieved here by simply giving the additional direction *non tratto*. When doing so, it needs to be noted that the dynamic level is – except for when exaggerated bow pressure is applied (cf. section ‘2. 3. 1 Exaggerated bow pressure’) – always relatively low. The articulation can be reversed by either giving the direction *tratto* or *arco*. Further, vertical motions can also be executed by means of the

¹ Cf. Gardner Read: Contemporary instrumental techniques New York and London 1976, p. 210.

hand itself or any kind of item. In such a case, the player needs to place down the bow. The method of notation introduced in the previous section (cf. figure 11) may then be employed for the right hand.

Further, it is theoretically possible to notate any kind of complex vertical bowing motion on the string by means of a second notation system. However, because one would have to constantly determine the string to which the depicted position is related, the appearance of the score would become confusing. Therefore, it is suggested here employing a variant of depiction, which enables the notation of switching strings during a vertical shift. In this method the strings upon which the bow is not placed are bracketed whilst a tetrad of fifths (or fourths) is the home position.

As can be seen in the example presented in figure 19, a violinist is supposed to attach his fingers to all strings on position $ab - eb^1 - b^1 - f^2/Ab3 - Eb4 - Bb4 - F5$ (for a detailed explanation of suchlike muting techniques see section '2. 6 Extended stopping techniques') for the duration of a semibreve. Simultaneously, a bow-*glissando* is performed: in the beginning solely vertical bowing is applied since the direction *non tratto* is given. The motion starts on the fingerboard. Because the two highest notes of the additional notation system are bracketed, the player applies the bow to the G- and D-string on position $g^1 - d^2/G4 - D5$. By passing the A-string, the bow is then moved down to $a^2/A5$ on the E-string for the duration of a crotchet. Hence the violinist needs to switch strings during the shift and performs a kind of oblique motion. Subsequently, the bow is moved to position $e^3/E6$ on the same string for the duration of another crotchet. When this position is reached, horizontal bowing (*tratto*; down-bow) complements the vertical shift, and the dynamic level is suddenly increased from *piano pianissimo* to *mezzopiano*. The bow is then moved to position $a^1 - eb^2/A4 - Eb5$ on the A- and D-string. Whilst moving the bow down, the player needs to additionally turn his wrist

since the interval is reduced to a tritone. Subsequently, the violinist performs a motion to the common *sul tasto* position (up-bow).

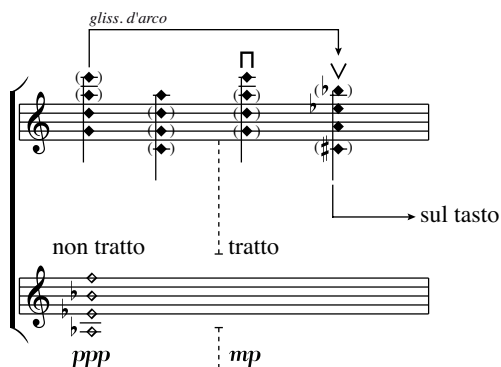

Fig. 19 Complex motions during the extended bow-*glissando*.

When the bow-*glissando* is performed on the common bowing positions, it is not possible to make the player turn his wrist since the alignment on the strings is not depicted. Moreover, when bowing one of the two outer strings in the area of the body, the player might be forced to additionally bow the body (cf. section ‘2. 5. 4 Bowing the body of the instrument’). Further, the bow-*glissando* may also be performed in combination with bowing techniques, such as *tremolo*, *col legno battuto*, *col legno tratto*, *gettato* etc. whilst the paradigm for the performance of complex motions on the string may be used to depict to all complex variants of the harmonic-*glissando* without bowing. Further, solely vertical *glissandi* may be performed with the wood of the bow, the screw (*glissando della vite*) or items, for example, in combination with a left-hand *pizzicato*.

Finally, there is an uncommon variant of the bow-*glissando* that can be only performed on the violincello and the contrabass. When requested, the player is supposed to place the bow in the space between fingerboard and body (*dietro il tasto*) and scratch the back of the fingerboard either with the hair or the wood of the bow. Such a vertical shift does normally not involve any horizontal motion. When employing this articulation, it may be useful to present an image of the action:

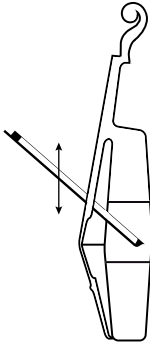

Fig. 20 Placing the bow between fingerboard and body.

In figure 20 it can be seen that a cellist is supposed to attach the wood of the bow to the back of the fingerboard and move it up and down. This **bow-glissando dietro il tasto** is depicted here by a notation system similar to Lachenmann's bridge clef. A special method of depiction needs to be used because the motion cannot be related to pitch. It consists of two components, a traditional timeline and a representation of the length of the fingerboard's back. The timeline is employed in order to establish a stronger relation to traditional notation whilst arrows depict what kind of motion the player is supposed to perform.

As apparent from figure 21, the cellist initially moves the bow up (here: towards the pegbox) for the duration of a crotchet and then back down for the duration of another crotchet. Subsequently, a two-headed arrow is employed. It requests the execution of a similar motion to the one previously defined as *trill-glissando*. Since all articulations are connected by a *legato* slur, they need to be performed in a continuous way and hence without releasing the bow. The dynamic level of these actions is always low. After a dotted quaver the player is then required to perform a *col legno battuto*. The point that is supposed to be hit with the bow's wood is depicted by a dot (also cf. section '4. 2. 6 Playing the snares').

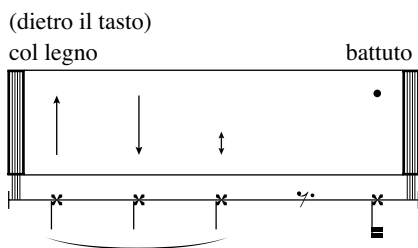

Fig. 21 The bow-*glissando dietro il tasto*.

2.3 Extended bowing techniques

Besides the basic bowing techniques, such as *legato*, *portato*, *staccato*, *gettato*, *tremolo* etc., as well as the basic *col legno battuto* and *tratto*, there are a number of extended techniques that are deprived of a conventional method of notation. These are the **exaggerated bow pressure**, **extended *battuto* and *tratto* techniques**, the articulations ***saltando*, *balzando* and *toccato*** and the **rolling bow**.

2.3.1 Exaggerated bow pressure

The technique of applying exaggerated bow pressure has been used by various composers. When requested, the player is supposed to increase the string tension, e. g. by means of the right thumb¹, and/or apply more pressure to the string as usual. The resulting sound may be described as rough and scratchy², a dry rattling³ or noisy and grating⁴.

¹ Sevsay, Handbuch, p. 82.

² Ibid., p. 82.

³ Lachenmann, Torso, no page named [foreword].

⁴ Brian Ferneyhough: Incipits. Solo viola, percussion and six instruments. London et al. 2002, no page named [foreword].

2.3.1.1 Previous methods of notation

The articulation is notated in many different ways. One is to employ a special note head, as utilised by Ferneyhough in *Incipits*:

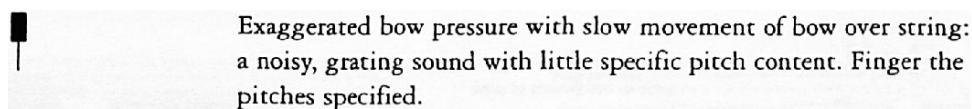

Fig. 22 Ferneyhough, *Incipits*, no page named [foreword].

Further, Dittrich makes in his *Streichquartett III* use of two different note heads that depict two degrees of bow pressure, high [starker] and extremely high bow pressure [mit überstarkem Bogendruck]:

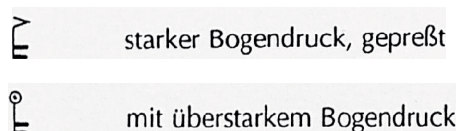

Fig. 23 Dittrich, *Streichquartett III*, p. 3.

Another method is to complement the note by a symbol. For instance, Crumb, in *Echoes of time and the river*¹, makes use of a symbol that resembles the depiction of a *vibrato*. As apparent from figure 24, a gradual decrease of the bow pressure is depicted by a direction and changing the shape of the line (see the four lowest notation systems).

¹ George Crumb: *Echoes of time and the river*. Four processions for orchestra. New York 1986.

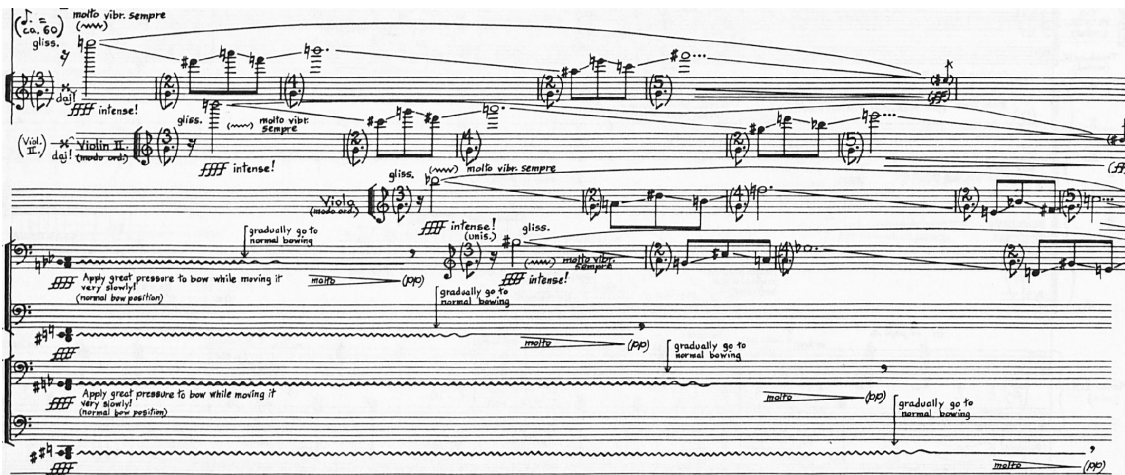

Fig. 24 Crumb, *Echoes*, p. 12.

Moreover, Lachenmann, in *Staub*, notates the technique in a similar manner. Here the symbol may be clearly differentiated from a *vibrato*, but no degrees of pressure are determined:

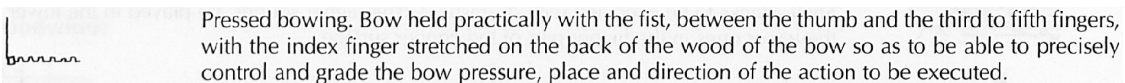

Fig. 25 Lachenmann, *Staub*, no page named [foreword].

Further, Henze, in his *4th string quartet*¹, utilises no note heads, but a symbol that replaces the note:



Fig. 26 Henze, *4th string quartet*, p. 7.

¹ Hans Werner Henze: *4th string quartet*. Mainz 1976.

Finally, some composers place symbols over the note that is supposed to be bowed with exaggerated pressure. Most commonly, they are derived from the common up-bow and down-bow symbol. Examples for this can be, for instance, found in Holliger's *Vier Lieder ohne Worte*¹ or Kagel's *Streichquartett I/IP* and *Match*³:

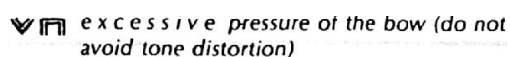

Fig. 27 Kagel, *Match*, p. 4.

2.3.1.2 Discussion

Concerning the first approach of depicting exaggerated bow pressure by means of special note heads, it may be said that Dittrich's method (cf. figure 23) may be preferred to that of Ferneyhough (cf. figure 22) since it is more exact with regard to notating different degrees of bow pressure. However, it may generally be difficult to request the transition between two degrees of pressure or, for instance, sounds that already require special note heads, such as harmonics, in combination with exaggerated bow pressure when employing such a method of notation. Moreover, each of the three note heads cannot be used in the case of notating minims or semibreves.

Further, when compared, Lachenmann's method of complementing the note by a symbol (cf. figure 25) may be preferred to that of Crumb (cf. figure 24). This is because Crumb's method makes use of a symbol that is normally employed for requesting *vibrati*. Such an addition can hence, as mentioned, not be regarded as legitimate since it is not distinct to another sign of the system even though an unrelated action is depicted. In order to guarantee consistency, only similar articulations should be depicted by similar symbols and all signs used in a distinctive way. However, despite being

¹ Cf. Heinz Holliger: *Vier Lieder ohne Worte*. Mainz 1987, p. 15.

² Cf. Kagel, *Streichquartett I/II*, p. 2.

³ Mauricio Kagel: *Match*. For three players. London 1967.

preferred to Crumb's method, Lachenmann's approach lacks exactness when concerned with the notation of different pressure degrees as well as with the depiction of the action's exact duration. Further, the extension of Lachenmann's method by more than one pressure degree – as it is kind of applied by Henze (cf. figure 26) – would still remain inexact because the duration of the action was not clearly indicated. Additionally, Henze's approach barely enables the depiction of the fingering. A more exact variant of notation would rather place a symbol over the note and depict the fingered pitch than to replace or complement the note head.

In the case of requesting exaggerated bow pressure by a means of a symbol, a simple method would be quickly identifiable as a depiction of the articulation it requests. Since the symbol displayed in figure 27 is stronger related to applying pressure to the bow, it is preferred here to those introduced by Lachenmann and Henze. However, it would have to be further extended when depicting more than one pressure degree (e. g. by means of an additional up-bow or down-bow symbol) whilst the transition between pressure degrees could then be depicted by utilising *de-/crescendo* symbols. Nevertheless, the extended up-bow or down-bow symbol would, due to its relation to bowing techniques, always refer to string instruments. Hence when requesting increased pressure in any other context another sign would have to be introduced and by doing so, the number of symbols increased. Therefore, a general symbol for the increase of pressure – which may also be utilised when requesting similar actions on other instruments¹ – is in the following section introduced.

¹ The increase of bow pressure is the only unconventional articulation the symbol is used for in this work. However, pressure degrees may be, for instance in the case of producing multiphonics on woodwinds, employed for an increased lip tension or blowing pressure.

2. 3. 1. 3 Suggestion for the notation of exaggerated bow pressure

Two degrees of bow pressure – 1. Increased pressure and 2. Highest possible pressure – are used here and, as apparent from figure 28, depicted by two similar symbols. A low pressure could analogously be depicted by means of two white arrows.

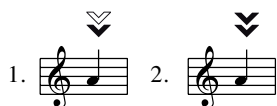

Fig. 28 The pressure degrees.

In figure 29 the player is supposed to bow a semibreve *a¹/A4* and, while doing so, increase the bow pressure from ‘increased pressure’ to ‘highest possible pressure’ for the duration of a crotchet. Subsequently, the bow pressure is decreased to the ordinary level – which is requested by the direction *arco* – for the duration of a minim. For the rest of the note’s duration, common bow pressure is applied.

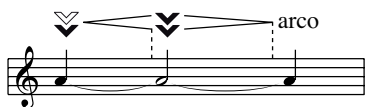

Fig. 29 The *de-/crescendo* of pressure degrees.

The dynamic level is always high when applying exaggerated bow pressure. Furthermore, this technique may complement the bow-*glissando*¹, including the solely vertical variant (cf. section ‘2. 2. 2 The bow-*glissando*’).

2. 3. 2 Extended *battuto* and *tratto* techniques and their notation

There are a number of ways to extend the normal *col legno battuto* and *tratto*. In the case of the former, the hit on the strings may also be performed by applying the bow’s

¹ As, for instance, requested in Helmut Lachenmann: „... zwei Gefühle ...“, Musik mit Leonardo. For speakers and ensemble. Wiesbaden et al. 2002, pp. 1f., 7, 9-12 etc.

wood and hair simultaneously (notation: *1/2 legno battuto* or *mezzo legno battuto*)¹ or only the bow's hair (notation: *col arco battuto*)². Similarly, the latter technique may also simultaneously involve the bow's wood and hair (notation: *1/2 legno tratto* or *mezzo legno tratto*)³. Since these three articulations derive from, and are strongly related to, the common *col legno battuto* and *tratto*, they can be notated in the same way: by employing the displayed directions.

However, there are some extended *battuto* articulations that need to be examined more thoroughly. One is to hit the string (and fingerboard) with the screw of the bow. The most common way of applying such a ***battuto with the screw*** can – as in the case of the bow-screw *pizzicato* (cf. figure 7) and in accordance with all other *battuto* techniques – be requested by the direction *colla vite battuto* or a symbolic representation of the screw:

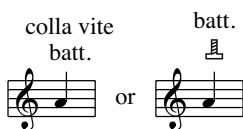

Fig. 30 *Battuto* with the screw.

The displayed method of depiction, however, needs to be further augmented when the hit is supposed to be performed on the fingerboard. This articulation is applied by Lachenmann in *Toccatina*. As can be seen in figure 31, a violinist is, during the performance of such actions on the fingerboard, supposed to constantly mute the E-, A- and G-string as well as finger the first node of the fifth partial on the D-string (cf. section ‘2. 6. 2 Exact muting stops and their notation’). Moreover, Lachenmann makes use of squared note heads to depict the position on the fingerboard where the screw hits

¹ Cf. Kagel, *Match*, p. 3.

² Cf. Lachenmann, *Torso*, no page named [foreword] or *Nono*, *Fragment*, p. 1.

³ Cf. Brian Ferneyhough: *Third string quartet*. London et al. 1988, p. 3.

the string and, if needed, a second transposed notation system. As mentioned, he additionally employs a technique designated by him as *screw pizzicato*, which is depicted by means of note heads that resemble the shape of a *Bartók pizzicato* symbol and refer to the position where the player mutes the strings with the left hand. However, this action may be rather regarded as a *battuto* since the screw of the bow is used to knock on the fingerboard and, when doing so, slightly touches the string before the fingerboard is hit^{1/2}.

Dämpfgriff nicht zu locker, damit die Tonhöhen der „Schrauben-Pizzicati“ hörbar sind
Muting stop, not too loose, firm enough to enable the pitch of the "screw pizzicati" to be heard

Fig. 31 Lachenmann, Toccata, p. 3.

As shown in section ‘2. 2. 2 The bow-*glissando*’, bowing on the fingerboard is, in this work, depicted by means of an additional notation system and diamond-shaped note heads. Diamond-shaped note heads are used because the string is not depressed. This is also the case when playing a *battuto* with the screw on the fingerboard. Moreover, since the *screw pizzicato* was defined here as rather being a *battuto*, and the hit on the fingerboard is related to the *harmonic-glissando il tasto* (cf. section ‘2. 2. 1 The *harmonic-glissando* without bowing and its notation’), there is no need to introduce a special note head and refer to the muting stop when hitting the fingerboard. In order to notate the described articulations in a uniform manner, Lachenmann’s approach needs to be

¹ Lachenmann, Toccata, no page named [appendix].

² The English translation of the appendix is, in this case, confusing because it is explained that the “screw of the bow knocks on the fingerboard and touches the string at the same time” even though these actions are in the original German version clearly indicated as being successive.

slightly altered: in figure 32 the first ‘bar’ of the example presented in the previous figure, is adapted to the manner the bow-*glissando* was notated in figure 18. Hence the exact duration of the muting action is given, diamond-shaped note heads are used instead of squared ones, as well as the *battuto* on the fingerboard is uniformly depicted by means of an additional notation system and the direction *battuto*. Further, the symbol for the screw *pizzicato* is replaced by two connected note heads and the direction *il tasto* (which requests – similarly to the harmonic-*glissando il tasto* – to play the fingerboard itself). In the example the player is required to constantly hit the string (or fingerboard) with the bow’s screw (*sempre colla vite battuto* or, alternatively, a symbol for the screw and the direction *sempre battuto*) and four times slightly touches the string before the fingerboard is hit. In order to restore the original articulation, the direction *ordinario* is given. The direction is employed in brackets because it does not refer to the ordinary bowing position, but the *battuto* on the string. This method of notation may also be applied in the case of any other right hand articulation on the fingerboard, e. g. ordinary bowing, *pizzicato* or *col legno battuto*, and the left-hand *pizzicato* (cf. section ‘2. 1 Extended *pizzicato* techniques and their notation’).

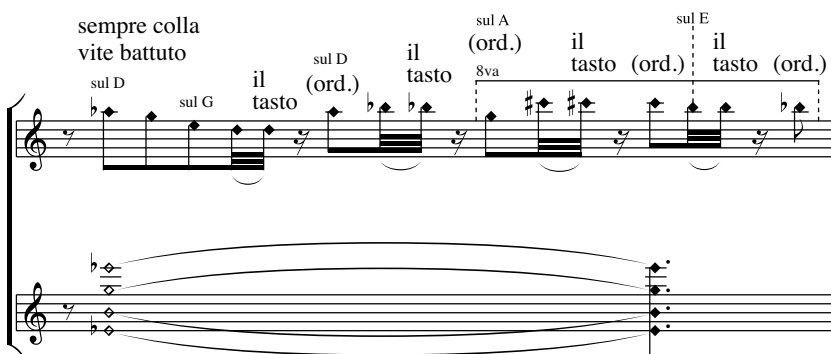

Fig. 32 *Battuto* with the screw on the fingerboard.

Another articulation is to utilise items other than the bow to hit the strings. This *battuto with items* is inter alia employed by Kagel in *Streichquartett III*. As can be seen in

figure 33, a cellist is supposed to hit the string close to the bridge with a knitting needle [mit Stricknadel am Steg geschlagen]. Additionally to giving the direction *battuto sul ponticello*, Kagel makes use of a triangular symbol that represents the needle.



Fig. 33 Kagel, Streichquartett I/II, p. 12.

Kagel's method of notation complies with the method employed for the depiction of the *pizzicato* with items. However, since the symbol Kagel utilises in figure 30 is commonly used for the plectrum *pizzicato* (cf. figure 5), another symbol – which is more strongly related to the actual shape of a knitting needle – should be chosen.

Finally, it is also possible to produce tones by fingering the strings without bowing. When doing so, the finger needs to strongly hit the string and push it against the fingerboard¹. This articulation is also sometimes referred to as tapping. Sevsay suggests that it should be notated by means of a circled plus sign:

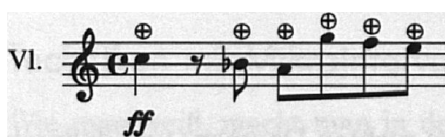

Fig. 34 Sevsay, Handbuch, p. 81.

However, since this action resembles the ordinary *battuto* articulation and can be compared to the performance of a left-hand *pizzicato*, it is rather regarded here as a **left-hand *battuto*** than a special manner of sound production. Therefore, it is suggested notating it, according to the left-hand *pizzicato*, as an extended *battuto* articulation by

¹ Sevsay, Handbuch, p. 81.

the direction *battuto* (*mano sinistra*), abbreviated *batt. (m. s.)*. Because the string is depressed and the fingered pitch evolves, a common note head needs to be employed:



Fig. 35 Left-hand *battuto*.

Two or more fingers may be, in the case of this technique, also involved as well as variations, such as a trill, trill-*glissando* or *vibrato* without bowing, be performed. In the case of requesting trills or *vibrati*, it might be useful to additionally explain that the action is performed *senza arco*¹. Further, another extended *battuto* technique, referred to as strokes on the string, is discussed in section ‘2. 7 Percussive effects’. This is because it is strongly related to a percussive technique designated as stop attack or dead stroke.

2. 3. 3 The *saltando*, *balzando* and *toccato* and its notation

There are a further three more articulations that may be regarded as variations of the common *col arco/legno gettato* and *col arco/legno battuto*. Lachenmann makes use of these and defines them adequately. ***Saltando***: “[d]ense shake of the bow after striking the string. (...) It is particularly important to avoid muddying the envisaged (...) pitches by accidental horizontal motions of the bow during the shake”². ***Balzando***: “[a] gentle ‘bouncing’ of the bow on the string by its own weight. This produces a very gradual accelerando of the bouncing sound”³. Both actions may be performed *col arco* and *col legno*.

¹ Cf. *ibid.*, p. 81.

² Lachenmann, *Torso*, no page named [foreword].

³ *Ibid.*, no page named [foreword].

Further, Lachenmann utilises two different methods for their notation: in *Klangschatten – mein Saitenspiel*¹ a special note (and the addition *legno saltando*) is used for the depiction of the *col legno saltando*², but none of the other techniques are applied³, whereas in *Gran torso* the articulations are notated by giving the directions *saltando*, *legno saltando* and *arco balzando* (whilst the *legno balzando* does not occur)⁴. Further, in the case of the *balzando* articulation, Lachenmann differentiates between a bowed and an unbowed performance: “[i]n this performance technique, a vertical arrow in the note tail (..) signifies that an up- or down-bow motion should be avoided”⁵.

However, since the described techniques may be, as mentioned, regarded as variations of the *col arco/legno gettato* and *col arco/legno battuto* and these articulations are conventionally depicted by means of directions, the introduction of special notes would mean to give up a close relation to traditional notation. Moreover, it would result in a more complex notation system. Hence in order to notate these articulations in a uniform manner, they are requested here by means of directions:



Fig. 36 The *saltando* and *balzando* techniques.

Furthermore, concerning the *balzando*, the unbowed performance of this technique is regarded here as the standard variant. In order to request a bowed performance, the direction *gettato* may be used in combination with a low dynamic level, which then

¹ Helmut Lachenmann: *Klangschatten – mein Saitenspiel*. For 48 strings and 3 grand pianos. Cologne 1978.
² Cf. *ibid.*, p. 19.
³ Cf. *ibid.*, no page named [foreword].
⁴ Cf. Lachenmann, *Torso*, no page named [foreword], pp. 1 and 4f.
⁵ *Ibid.*, no page named [foreword].

requests not to throw the bow, but merely requires the combination of the *balzando* bouncing with an up- or down-bow motion. As a reminder, the *gettato* may generally be only performed with a high dynamic level. However, a soft variant of this technique may also be executed¹. In such a case, the bow rather bounces on the string instead of being thrown. The lower the dynamic level, the less forceful is the initial attack. A variant of notation would be to introduce a special direction for the soft *gettato* analogously to the differentiation between the *saltando* (which can be regarded as an unbowed *gettato*) and *balzando* (which can be regarded as an unbowed soft *gettato*). The *saltando* can analogously not be performed with a very low dynamic level and the *balzando* not with a very high dynamic level whilst higher dynamic levels are generally produced by using the wood of the bow.

Moreover, it needs to be noted that the *saltando* may be kept going: “[t]he phase of the most rapid bouncing up and down is prevented from dying out when the bow is tossed upwards again and again by a minimal and highly sensitive push in a down-bow motion – nothing more than a minute horizontal frictional resistance. The dense final phase of the rapid bouncing then perpetuates itself in this manner without interruption ad infinitum”². Its notation can be achieved by simply utilising longer durations and *ad libitum* the direction *perpetuo*, meaning that the action is performed in a perpetual way. Additionally, all motions may be performed vertically and on the fingerboard.

The third variation, here designated as *toccato*, can be only performed *col legno*. A sound effect is achieved when the previously struck string is still vibrating. The technique is most effective on the cello and contrabass. Lachenmann, in *Klangschatten – mein Saitenspiel*, makes use of this technique only in combination with contrabasses:

¹ Cf. Sevsay, Handbuch, p. 41.

² Lachenmann, Torso, no page named [foreword].

“[a]fter the left hand has jerked the string sharply, place the bow stick very gently on the string. The vibrating string should thus clatter loudly upon contact with the wood of the bow. In order to have the rattling sound last as long as the given duration, the contact of the bow stick with the vibrating string must be brought about very cautiously”¹. He depicts the *legno toccato* [legno berühren] by means of a special note tail, which is complemented by a sign resembling a ‘Z’:



Fig. 37 Lachenmann, *Klangschatten*, p. 35.

However, the *col legno toccato* is – as are the *saltando* and *balzando* articulations – strongly related to traditional bowing techniques. Therefore, it is suggested here not depicting it by means of a special symbol, but requesting it by means of a direction. The point of attachment may be either determined by means of the three common bowing positions or – in the case of attaching the bow on the fingerboard – in the same way as the bow-*glissando* and hence by means of an additional notation system and diamond-shaped note heads (cf. section ‘2. 2. 2 The bow-*glissando*’). In the example presented in figure 38, the *toccato* articulation is depicted. A contrabassist initially plays a *pizzicato sul tasto* on the open E-string with the dynamic level *fortissimo*. After the duration of a quaver, he subsequently performs a *col legno toccato* on the same position. Moreover, the *legato* slur underlines that the string lingers on when the player starts touching it

¹ Lachenmann, *Klangschatten*, no page named [foreword].

with the wood of the bow. The dynamic level of the *col legno toccato* is always dependent on the dynamic level of the preceding articulation and cannot be varied.



Fig. 38 The *col legno toccato*.

Additionally, it is also possible to execute a ***col legno toccato with the screw*** (*colla vite toccato*) or **with items**. A method of notation for these actions can be derived from the previous examples (cf. figure 7 for the screw *pizzicato* and figure 30 for the *battuto* with the screw, section ‘2. 1 Extended *pizzicato* techniques and their notation’ for the *pizzicato* with items and the previous section for the *battuto* with items). Further, another *toccato* articulation, referred to as the *buzz-pizzicato*, is discussed in section ‘2. 6. 2 Exact muting stops and their notation’. This is because it is strongly related to the depiction of muting stops.

2.3.4 The rolling bow and its notation

The technique designated as the rolling bow is rarely used in compositions. When requested, the bow is, as normal, attached to the string and “the wood of the bow pressed into the hair of the bow (...). As a result of the rolling motion of the pressed wood of the bow, the combined friction of the bow hair, the string and the wood of the bow produces a dryly crackling grinding”¹.

¹ Lachenmann, Torso, no page named [foreword].

Lehmann employs this technique in *Arco*¹, but only gives a verbal explanation and explains that this and other articulations “can be distributed freely”². Moreover, Lachenmann gives the verbal explanation: press the wood into the hair (slow rolling motion) – grinding [Stange ins Bogenhaar gedrückt (langsame Rollbewegung) – knirschend] and uses a zigzag line that replaces the note head in order to depict the action:

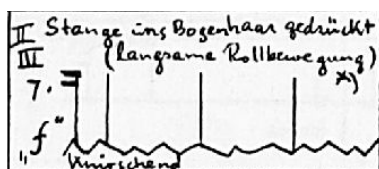

Fig. 39 Lachenmann, *Torso*, p. 2.

Since Lehmann does not specify the performance of the rolling bow articulation, his approach can be described as very approximate and, therefore, does not meet the requirement of exactness. Further, the complementation or replacement of a note by a symbol, such as the one introduced by Lachenmann, leads – as mentioned – to inexactness. This is because the duration of the action is not clearly indicated. Even though note tails are used in the example, minims and semibreves could not be depicted. Therefore, it is suggested here rather placing such a symbolic representation of the rolling bow over the note than replacing or complementing the note head. Nevertheless, the symbol seems to be adequate since the motion is related to the performance of a *vibrato*, which is notated by a wavy line. Moreover, the strings that are involved in this articulation need to be depicted. As apparent from figure 39, Lachenmann makes use, therefore, of Roman numerals. However, the strings could also be notated by means of a

¹ Hans Ulrich Lehmann: *Arco*. For violin. In: Eckart Schloifer (ed.): *Pro musica nova*. Studies for playing contemporary music. For violin. Wiesbaden 1986, pp. 27-31.

² *Ibid.*, p. 27.

pitch-based system and hence in closer relation to traditional notation. Such a method is suggested here.

As the influence of stops is negligible, the position of the bow is depicted by notating the open strings. In figure 40 a contrabassist is supposed to attach the bow to the A- and E-string and perform a rolling bow articulation, which results in a grinding with the dynamic level *mezzoforte* and the duration of a semibreve. The optional direction *rotolato* (rolled) is additionally employed in order to emphasise what kind of motion the player is supposed to execute.

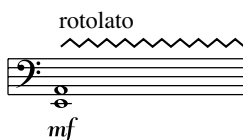

Fig. 40 The rolling bow.

Moreover, it may be requested to let the strings vibrate after the action (*lasciar vibrare*) or to execute an irregular rolling motion (*irregolare*) while speed levels may also be introduced. Further, the rolling bow may be performed on the fingerboard, behind the bridge or on the body (cf., for instance, figure 32 for the notation of playing on the fingerboard, section '2. 4. 4 Playing behind the bridge' for playing behind the bridge and section '2. 5. 4 Bowing the body of the instrument' for the rolling bow articulation on the body). Finally, left-hand *pizzicati* or *battuti* may complement the articulation. They would then have to be depicted in a distinct notation system.

2. 4 Extended playing positions on the string

This section focuses on uncommon bowing positions and stops on the string, including the **highest possible tone, fingering in between fingerboard and bridge, bowing on the bridge, playing behind the bridge/on the tailpiece and fingering behind the**

bridge. Because it is often employed as an extended *glissando* technique, bowing on the fingerboard has been introduced in section ‘2. 2. 2 The bow-*glissando*’. Moreover, it is also discussed in section ‘2. 3. 2 Extended *battuto* and *tratto* techniques and their notation’.

2. 4. 1 The highest possible tone and its notation

In New Music the ordinary range of string instruments is often exceeded. *Sevsay* mentions that composers, for instance, notate a (written) $c^4/C7$ or even $c\sharp^4/C\sharp 7$ for the contrabass. Moreover, the highest possible tone is often also requested¹. In such a case, *Sevsay* suggests the following method of notation:



Fig. 41 *Sevsay*, *Handbuch*, p. 30.

This depiction of the highest possible tone may be described as nearly conventional. There are only slight differences between the methods composers employ: for instance, *Szalonek*, in *Concertino*², also makes use of triangular note heads pointing upwards to notate this articulation. However, he clearly indicates on which string the highest possible tone is supposed to be fingered:

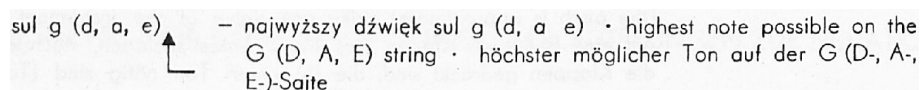

Fig. 42 *Szalonek*, *Concertino*, p. 4.

¹ Cf. *Sevsay*, *Handbuch*, p. 30.

² Witold Szalonek: *Concertino*. For flute and chamber orchestra. Warsaw 1965.

Further, Cervetti, in *Zinctum*, depicts the string upon which the highest possible tone is fingered by means of the notation system¹:

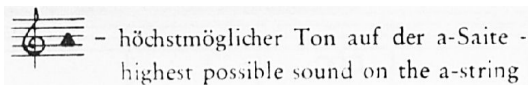

Fig. 43 Cervetti, *Zinctum*, no page named [appendix].

Since Szalonek's and Cervetti's methods imply a determination of the string, they are more exact and enable the production of more tones than Sevsay's method. However, there is no need to dismiss the traditional notation system – as is the case in Szalonek's approach – and Cervetti's method could be specified by exactly depicting the note's duration. Moreover, with regard to the notation of the string, it may be said that both alternatives are simple and exact. Consequently, Sevsay's method could be simply complemented by a determination of the string in order to be as exact as the other ones.

For these reasons, two suggestions for the notation of the highest possible tone (on the A-string of a violin) are presented in figure 44. The second method may be used preferably in the case of requesting the player to switch strings in fast succession.

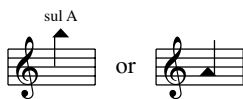

Fig. 44 The highest possible tone.

Further, the highest possible harmonic may also be requested. It can vary according to the technical capability of the player² and consequently be notated in the same way as the highest possible tone:

¹ This example may refer to a violin or viola.

² Sevsay, *Handbuch*, p. 80.

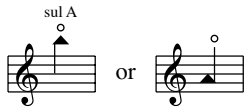

Fig. 45 The highest possible harmonic.

2. 4. 2 Fingering in between fingerboard and bridge and its notation

When the left hand leaves the fingerboard and moves into the space between the fingerboard and bridge, the method of notation needs to be augmented. This is because the sounds that evolve no longer have a definite pitch, and the position on the string may not be determined by means of pitch-based notation. When fingering in between fingerboard and bridge, squeaky sounds are produced.

Pröve utilises this playing technique in *Firebird*¹. As can be seen in figure 46, the fingers slide from the fingerboard into the space between bridge and fingerboard [Zwischen Steg u. Griffbrett]. At this point, an additional notation system is introduced. This system, which is referred to as the string clef system here, no longer depicts the pitch, but the position of the fingers on a particular string (string I of a violin in the example) by means of note heads derived from the notation of the highest possible tone. In the example the finger constantly slides up and down the E-string for the duration of five semiquaver quintuplets, eight demisemiquavers and seven semiquaver septuplets. Moreover, it seems as if three positions are depicted. The violinist plays the *glissando* in between fingerboard and bridge in the order of the lowest position, middle position, lowest position, middle position, lowest position, highest position, middle position etc.



Fig. 46 Pröve, *Firebird*, p. 7.

¹ Bernfried Pröve: *Firebird*. For violin alone. Celle 1993.

Concerning the agreement with the requirements, Pröve's approach may be described as closely related to traditional notation and simple. This is because the note heads he employs are derived from the (nearly) conventional way of notating the highest possible tone and the notation system he uses may be easily comprehended. However, his approach lacks exactness because it is unclear how many fingering positions there are in between fingerboard and bridge. Moreover, an additional grid would have to be introduced in order to clearly depict these positions. But at the same time, the introduction of a grid – and hence the addition of lines – would complicate the string clef system.

Therefore, Pröve's approach towards the notation of the articulation is augmented here by defining exact positions and depicting these by means of a slightly varying string clef system and accidentals. The system employed here consists of five lines and replaces the traditional system instead of being placed over it. Each spacing in between the lines refers to one of the four strings. For each string instrument four distinct stops are employed. They were determined by experience with regard to the violin: position 1 can be described as the closest to the fingerboard. It is depicted by the accidental \flat . The next position is located further to the bridge and is required when no accidental is employed. These positions may be fingered when bowing *ordinario* or *sul ponticello*. Moreover, positions 3 and 4 can be only fingered when bowing *sul ponticello*. They are depicted by the accidentals \sharp and \natural whilst position 4 (double sharp) is located closer to the bridge. In the example presented in figure 47, the string clef system of a violin is displayed. The positions are depicted in the order of position 1 on the G-string, position 2 on the D-string, position 3 on the A-string and position 4 on the E-string.

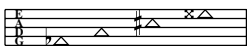

Fig. 47 Fingering in between fingerboard and bridge.

Concerning the positions, there is no distinction made between the string instruments in order to preserve uniformity. This means that even though it might be possible to produce more sounds on a contrabass by fingering more than four positions, it is neglected in order to enable the application of the same method of notation for all four string instruments. However, when a five-stringed contrabass is used, an additional string needs to be introduced to the string clef system (also cf. figure 258 in the chapter on plucked instruments). Further, all common bowing techniques, such as *legato*, *tremolo*, *gettato*, *battuto* etc. as well as all normal fingering techniques, such as *vibrato*, the trill, *glissando* etc. can be employed when playing in between the fingerboard and bridge.

2. 4. 3 Bowing on the bridge

When bowing on the bridge, a whirring sound with indefinite pitch evolves¹. This articulation has been employed by various composers. When requested, the player is normally supposed to additionally mute the strings in order to keep them from vibrating².

2. 4. 3. 1 Previous methods of notation

Despite the articulation having been used frequently, no definite method of notation has yet been established. Sevsay suggests employing either a traditional notation system or a string clef system, a special symbol (which resembles the shape of the bridge) added to the note tail and x-shaped note heads:

¹ Sevsay, Handbuch, p. 58.

² Cf. Lachenmann, Staub, no page named [foreword].

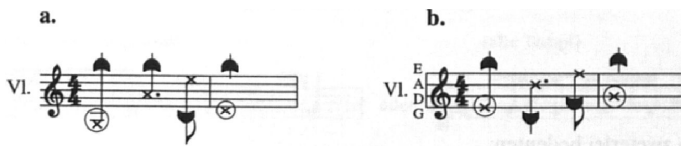

Fig. 48 Sevsay, Handbuch, p. 58.

This method of notation resembles the one utilised by Lachenmann in *Mouvement (– vor der Erstarrung)*¹. In this piece he makes use of a note head shaped like a semi-circle (depicting the bridge) and a black square to request this playing technique. However, Lachenmann does not determine the strings the player is supposed to bow. As can be seen in figure 49, a circled plus sign further complements the depiction of this playing technique. It is employed in order to emphasise that the strings are muted when bowing on the bridge.



Fig. 49 Lachenmann, *Mouvement*, p. 1.

Furthermore, as already displayed in figure 8, Lachenmann, in *Pression*, also makes use of a bridge clef to depict the articulation. As a reminder, the traditional timeline is replaced by division lines whilst each line represents a crotchet². In order to determine that the player is supposed to bow the A-string, Lachenmann gives the verbal explanation string I [I. Saite]:

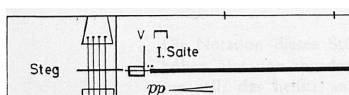

Fig. 50 Lachenmann, *Pression*, p. 2.

¹ Helmut Lachenmann: *Mouvement (– vor der Erstarrung)*. For ensemble. Wiesbaden 1985.

² Cf. Lachenmann, *Pression*, p. 1.

Moreover, Holliger requests the articulation by means of a special note head shaped like a bridge, but does not clearly indicate which strings are supposed to be bowed:

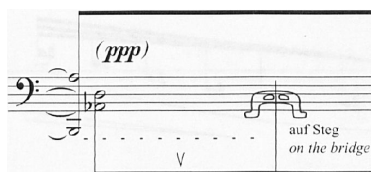

Fig. 51 Holliger, Duo II, p. 21.

Another method of notation is employed by Dittrich in his *Streichquartett III*. As can be seen in figure 52, playing directly on the bridge [direkt auf dem Steg spielen] is requested by a squared note head and a special tail. The string is in the piece depicted by means of the traditional system¹.

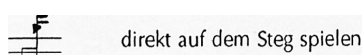

Fig. 52 Dittrich, Streichquartett III, p. 2.

2. 4. 3. 2 Discussion

Sevsay's approaches towards the notation of playing on the bridge (cf. figure 48) may both be described as complying with the requirements. They are simple, exact and closely related to traditional notation. However, as apparent from the example, it might be confusing to add a symbol to the note tail when semibreves or additional *tremolo* symbols are employed. Therefore, it is preferred here to solely use a special note head to request the articulation. Moreover, in order to achieve a uniform method of notation for all playing positions on the string that produce an indefinite pitch, the string clef system is favoured from the traditional system. Concerning Lachenmann's first method of notation (cf. figure 49) it may be said that it is not able to depict minims and semibreves.

¹ Cf. Dittrich, *Streichquartett III*, pp. 58f.

Additionally, the utilised strings could be only depicted by means of directions. Moreover, his second approach (cf. figure 50) is not closely related to traditional notation. Further, the bowed string(s) may generally be depicted in a simpler manner by means of the string clef rather than by the bridge clef system.

Holliger's approach (cf. figure 51) may be judged similarly because it does not enable the depiction of minims and semibreves. Additionally, the determination of the strings by means of the notation system becomes complicated when using such a complex note head. In opposition, Dittrich's approach (cf. figure 52) – which resembles the one by Sevsay – agrees with the postulated requirements since it is simple, exact and closely related to traditional notation. However, when the squared note head already clearly requests the articulation, there is no need for utilising a symbol added to the note tail, which might, as mentioned, also cause confusion. In order to ensure that the note head distinctly depicts the playing technique, it needs to be distinct to all other note heads of the system. Further, in order to preserve uniformity, the string clef system is, as mentioned, in this context preferred to the traditional system.

2.4.3.3 Suggestion for the notation of bowing on the bridge

It is hence in the following section suggested employing the string clef system and a special note head in order to depict the technique of bowing on the bridge. The note head employed for the depiction of this playing technique is derived from the one employed by Lachenmann in *Pression* and Dittrich in his *Streichquartett III*. This is because it is a commonly applied note head and kind of symbolises a middle stage between fingering between fingerboard and bridge (which is, as apparent from figure 47, depicted by triangular note heads pointing upwards) and fingering behind the bridge

(which is, as shown in the following section, requested by triangular note heads pointing downwards).

In figure 53 the suggested method of notation for playing behind the bridge is presented. In the example a violinist is supposed to initially bow the D- and G-string on the bridge for the duration of a minim and subsequently play a succession of quavers on the A-, G-, D- and E-string. These quavers are played *staccato*. Other common playing techniques can also be employed when bowing on the bridge. However, it needs to be noted that it becomes difficult to bow exactly on the bridge when, for instance, a *gettato* is requested. Further, a *col legno battuto* would solely result in the wood of the bow hitting the wood of the bridge.



Fig. 53 Bowing on the bridge.

Muting the strings when bowing on the bridge is regarded here as the common way of executing this playing technique. Therefore, an additional symbol, as applied by Lachenmann in *Mouvement (– vor der Erstarrung)* (cf. figure 49), is not utilised. Moreover, when the open strings are supposed to sound during, or at some point of, the articulation the direction *lasciar vibrare* may be given. The impact of fingering tones whilst bowing on the bridge is negligible. However, it is possible to bow with one half of the hair on the bridge and with the other half on a very extreme *sul ponticello* position. When doing so, tones mix with the indefinite whirring sound. This articulation may be depicted by means of traditional notation and squared note heads in combination with common note heads. Two note heads are applied here because two articulations/sounds mix. A variant of notation is to depict the additional bowing position by means of a direction. This fourth position could be designated as *il ponticello*. In figure 54 the

open A-string of a violin is bowed in this manner. Stops could be, as usual, requested by transposing the common note head.

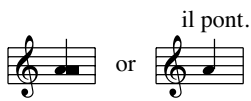

Fig. 54 Bowing on the bridge and *sul ponticello* simultaneously.

2.4.4 Playing behind the bridge

When playing behind the bridge, squeaky sounds with indefinite pitch evolve¹. Despite being one of the most important playing techniques in New Music², no conventional method of notation has yet been established.

2.4.4.1 Previous methods of notation

Sevsay suggests notating the articulation of playing behind the bridge similarly to bowing on the bridge and hence by means of a symbol added to the note tail and x-shaped note heads:

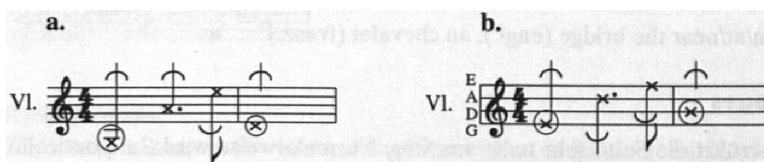

Fig. 55 Sevsay, Handbuch, p. 58.

A similar method of depiction is employed by Crumb in *Echoes of time and the river*. He makes use of a traditional notation system and employs x-shaped note heads to request the articulation:

¹ Sevsay, Handbuch, p. 58.

² Samuel Adler: The study of orchestration. 3rd edition. New York and London 2002, p. 49.

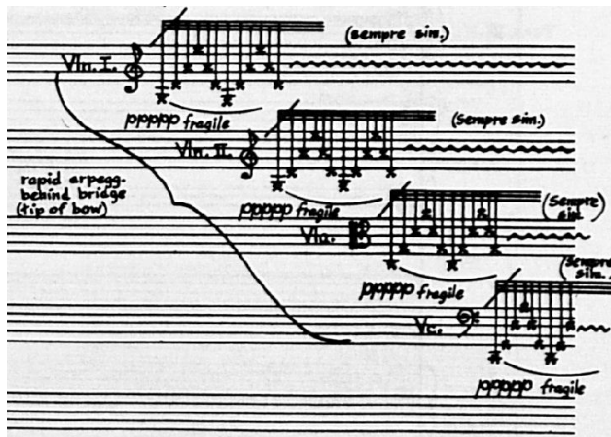

Fig. 56 Crumb, Echoes, p. 9.

The same method is applied by Maderna in *Widmung*¹. In the example presented in figure 57, a violinist is supposed to pluck the G- and D-string of a violin behind the bridge.



Fig. 57 Maderna, Widmung, p. 6.

Moreover, in *Threnody*² Penderecki utilises the symbol Sevsay adds to the note tail in order to replace the note head:

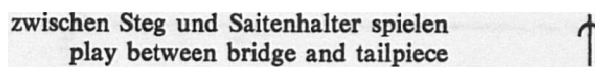

Fig. 58 Penderecki, Threnody, p. 3.

Another note head is applied by Lachenmann in *Klangschatten – mein Saitenspiel*. The strings are, in this case, depicted by means of Roman numerals:

¹ Bruno Maderna: *Widmung*. For violin alone. Milan 1976.

² Krzysztof Penderecki: *Threnody*. To the victims of Hiroshima. For 52 strings. London et al. 1961.



4. signifies: below the bridge. The Roman numeral indicates which string is intended. The pizzicato below the bridge is always to be executed with the fingernail or a plectrum.

Fig. 59 Lachenmann, Klangschatten, no page named [foreword].

Further, in *Pression* Lachenmann again makes use of the bridge clef in order to notate a vertical motion of the bow behind the bridge:

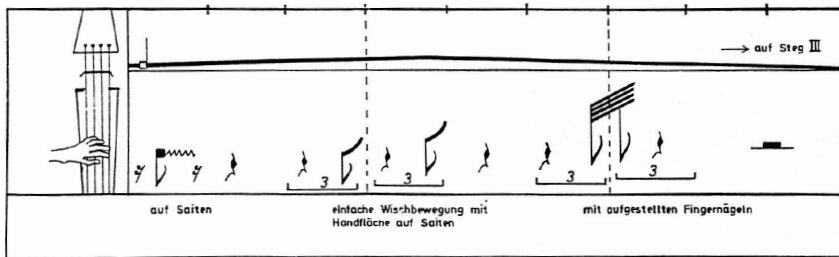

Fig. 60 Lachenmann, *Pression*, p. 6.

2.4.4.2 Discussion

The methods of notation employed for playing behind the bridge resemble the ones applied for bowing on the bridge and may be judged similarly: with regard to Sevsay's methods (cf. figure 55), it is hence preferred to request the technique by means of the note head instead of by adding a symbol to the note tail as well as to utilise the string clef instead of the traditional system. The note head may be x-shaped, as in the case of Crumb's and Maderna's approach (cf. figure 56 and 57), but should rather not look like the symbols employed by Penderecki and Lachenmann (cf. figure 58 and 59). This is because x-shaped note heads may be used to depict any duration, whereas minims and semibreves could not be notated by means of the other two symbols. As in the case of bowing on the bridge, the string clef system is also preferred here to the bridge clef system. As shown in the following section, a vertical motion (cf. figure 60) may be,

furthermore, depicted similarly to the bow-*glissando* (see section ‘2. 2. 2 The bow-*glissando*’).

2. 4. 4. 3 Suggestion for the notation of playing behind the bridge

The note head utilised to depict the articulation of playing behind the bridge is derived from the one employed by Crumb and Maderna. This is because it is a commonly applied note head and often used to request playing behind the bridge. Further, since the bowing position has an impact on the resulting sound when playing behind the bridge, the method of notation needs to be further augmented. With respect to the three traditional bowing positions, three positions are defined for the area behind the bridge. They are also requested by means of directions and strongly related to the common positions:

Sul ponticello also requests to bow close to the bridge. However, in this case, on the other side of the bridge. The next position is designated as *ordinario* and located in the middle of the string length (from bridge to tailpiece). Moreover, the position that corresponds to *sul tasto* is called *sulla cordiera* (on the tailpiece) and requests to bow close to the tailpiece. This position is located on the fabric covering of the strings and as close to the tailpiece as possible. When bowing *sulla cordiera*, the tailpiece starts vibrating and a hum complements the squeak. As can be seen in figure 61, a violinist is supposed to initially bow the D- and G-string *sulla cordiera* behind the bridge for the duration of a minim and subsequently play a succession of quavers on the A-, G-, D- and E-string. The first two quavers are bowed *sul ponticello* and the last two ones on the position *ordinario*.

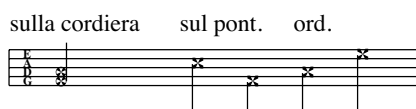

Fig. 61 Playing behind the bridge.

When playing behind the bridge, all common and extended playing techniques (except for the *Bartók* pizzicato) may be performed. The introduction of positions enables, as mentioned, the depiction of a bow-*glissando*. It can be notated in the same way as the one displayed in figure 17. Furthermore, it is also possible to bow the fine-tuners themselves. When doing so, the tailpiece vibrates and an additional hum sound evolves. This playing position is suggested here being requested by the string clef system, x-shaped note heads and the direction *sugli tiracantini* (on the fine-tuners).

2.4.5 Fingering behind the bridge and its notation

Another special articulation is to attach the finger to the strings whilst playing behind the bridge. This playing technique resembles the fingering in between fingerboard and bridge. The sounds that evolve may be described as ‘transposed’ squeaks. When this articulation is requested on the violincello or contrabass, it might be more comfortable for the player to sit down. Since there is a lack of previous adequate approaches towards the notation of this technique, the method of depiction is developed here in accordance with the related fingering in between fingerboard and bridge¹ (cf. section ‘2.4.2 Fingering in between fingerboard and bridge and its notation’) and the bowing positions defined in the previous section:

Fingering behind the bridge is suggested being requested by means of the string clef system and triangular note heads pointing downwards. The fingering positions correspond to the stops between fingerboard and bridge: position 1 can be described as the closest to the bridge. It is depicted by the accidental \flat . The next position is located further to the tailpiece and is required when no accidental is employed. These positions

¹ Even though the area in between the fingerboard and bridge is slightly longer than the area behind the bridge.

may be fingered when bowing *ordinario* or *sulla cordiera*. Moreover, position 3 and 4 can be only fingered when bowing *sulla cordiera*. They are depicted by the accidentals # and ✖ whilst position 4 (double sharp) is located closer to the tailpiece. In the example presented in figure 62, the four fingering positions are displayed by taking the example of a violin. They are fingered in the order of position 1 on the G-string, position 2 on the D-string, position 3 on the A-string and position 4 on the E-string.



Fig. 62 Fingering behind the bridge.

As in the case of the related fingering in between fingerboard and bridge, there is no distinction made between the string instruments in order to preserve uniformity. This means that even though it might be possible to produce more sounds on a contrabass by fingering more than four positions, it is neglected in order to enable the application of the same method of notation for all four string instruments. Further, all common bowing techniques, such as *legato*, *tremolo*, *gettato*, *battuto* etc. as well as all normal fingering techniques, such as *vibrato*, the trill, *glissando* etc. can be employed when playing behind the bridge.

2. 5 Playing exceptional spots

Besides the strings, all other parts of the violin, such as the **tailpiece** itself, the **side of the bridge**, as well as the **tuning pegs**, **peg box** and **scroll** may be bowed. Further, the **body of the instrument** may also be bowed.

2.5.1 Bowing the tailpiece

When bowing the tailpiece, a rushing evolves. Lachenmann describes it as a “veiled, almost eerie (..) sound”. Moreover, similarly to bowing the fine-tuners, the tailpiece vibrates when bowing it with a higher dynamic level.

2.5.1.1 Previous methods of notation

There have been several attempts to notate this articulation. For instance, Holliger, in *Duo II*, makes use of this technique. As can be seen in figure 63, he depicts it by presenting a drawing of the tailpiece and bow. The duration of the articulation is, however, only determined approximately.

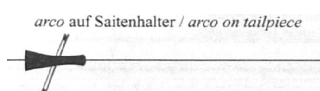

Fig. 63 Holliger, *Duo II*, p. 20.

Moreover, Lachenmann, in *Klangschatten – mein Saitenspiel*, requests to bow the tailpiece by means of a squared note head and a black triangle added to the note tail or, in the case of a *col legno tratto* on the tailpiece, by means of a squared note head and an additional white triangle:

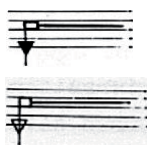

Fig. 64 Lachenmann, *Klangschatten*, no page named [foreword].

However, in *Gran torso* Lachenmann makes use of the bridge clef and squared note heads in order to depict this articulation:

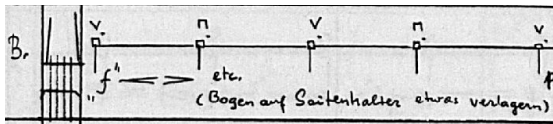

Fig. 65 Lachenmann, Torso, p. 11.

2. 5. 1. 2 Discussion

When comparing the displayed approaches, it may be said that Holliger's method (cf. figure 63) can be described as the simplest because the player can instantly understand what kind of action he is supposed to perform. However, the method of depiction is at the same time inexact since the duration is only determined approximately. Moreover, Lachenmann's first approach (cf. figure 64) requires the player to learn the meaning of an unrelated symbol. As mentioned before, it might also be problematic to add a symbol to the note tail. Further, Lachenmann's second method of notation (cf. figure 65) resembles the one by Holliger because a drawing of the tailpiece is also employed here. It may be, however, described as more exact because the point of contact between the bow and the tailpiece is depicted and the duration clearly determined. A method of notation that complies with all criteria would hence be as simple as Holliger's approach, but describe the point of contact and the duration in an exact manner.

2. 5. 1. 3 Suggestion for the notation of bowing the tailpiece

In order to depict the articulation of bowing the tailpiece in a simple and exact way, a hybrid of the described methods is suggested. The method of depiction used here, however, employs x-shaped note heads and a single lined notation system with no clef instead of squared note heads and a bridge clef. This is because x-shaped note heads are normally utilised for the notation of noisy sounds (cf., for instance, the chapter on percussion instruments). Further, the drawing of the tailpiece is – with regard to the

notation of the other exceptional spots discussed in the following sections and in order to achieve a greater degree of instantaneous comprehension – presented here as a part of the whole instrument and the bow symbol complemented by an arrow, which determines the spot that is bowed.

As can be seen in figure 66, a cellist is supposed to bow the tailpiece at the point designated by the arrow for the duration of a semibreve. When requesting this articulation, it needs to be noted that the dynamic level may become quite high (because the tailpiece vibrates) and the basic bowing techniques, such as *arco*, *tremolo*, *gettato*, *col legno tratto* (low dynamic level), *col arco battuto* etc. may be employed. Additionally, the rolling bow technique (cf. section ‘2. 3. 4 The rolling bow and its notation’) may be utilised when bowing the tailpiece. A similar extension of this technique is discussed in section ‘2. 5. 4 Bowing the body of the instrument’. The paradigm presented there may be easily transferred to bowing the tailpiece.

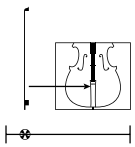

Fig. 66 Bowing the tailpiece.

Moreover, the bow may be moved vertically on the tailpiece. This motion can either be executed with or without horizontal bowing. The notation of this technique is suggested here being achieved similarly to the bow-*glissando* on the strings (see section ‘2. 2. 2 The bow-*glissando*’ for a detailed explanation). In figure 67 a vertical and horizontal motion in combination is displayed. The cellist is in the example again supposed to start bowing close to the fine-tuners. However, this time the bow is during the bowing motion moved towards the endpin (*glissando d’arco*). The latter position is reached after a dotted minim (up-bow). The player is then supposed to bow this position for the

duration of a crotchet (down-bow). A solely vertical motion would, in this case, also be requested by the direction *non tratto*.

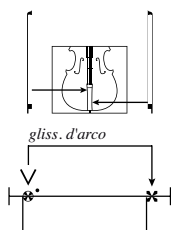

Fig. 67 Bow-glissando on the tailpiece.

2. 5. 2 Bowing the side of the bridge

Bowing the side of a cello's or contrabass's bridge results in a "clear toneless bowing sound"¹. However, when bowing close to the slit of the bridge, squeaky "whistling tones can occur"². Since the bridges of violins and violas are smaller, only squeaky sounds can be produced on them.

2. 5. 2. 1 Previous methods of notation

Holliger, in *Duo II*, makes use of this technique. As can be seen in figure 68, the note head is replaced by a drawing of the bridge and bow in order to request this articulation. In the example a cello's bridge is played. Holliger indicates whether the sound should be squeaky or toneless by means of directions. Further, when requesting squeaky sounds, the note head is placed higher than when requesting toneless sounds.

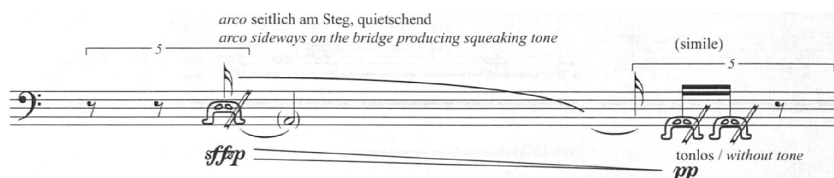

Fig. 68 Holliger, *Duo II*, p. 20.

¹ Lachenmann, *Mouvement*, no page named [foreword].

² *Ibid.*, no page named [foreword].

Moreover, Lachenmann depicts this articulation in two ways. As can be seen in figure 69, in *Mouvement* (– vor der Erstarrung) an abstracted bridge clef is utilised in combination with a white squared note head. This method of notation resembles the one that requests the player to bow on the bridge (cf. figure 49) or behind the bridge (cf. figure 59). When applied, the player is always supposed to produce a toneless sound, and the squeaky whistling is not requested¹.



Fig. 69 Lachenmann, *Mouvement*, no page named [foreword].

Further, Lachenmann, in *Pression*, makes use of another method, which also enables the depiction of a vertical motion. The notation system he employs may be described as a ‘side of the bridge clef’. In the example presented in figure 70, a cellist is supposed to perform a *col legno battuto* on the lowest point of the bridge [legno-Schlag auf Stegfuß] and subsequently bow the side of the bridge [arco unter den Saiten auf Stegwand].

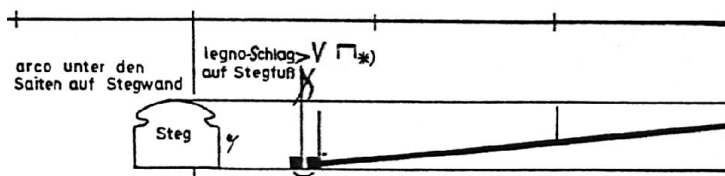

Fig. 70 Lachenmann, *Pression*, p. 4.

2.5.2.2 Discussion

Holliger’s approach (cf. figure 68) agrees with the requirement of simplicity and is closely related to traditional notation. This is because it can be easily comprehended what kind of action is supposed to be executed and the traditional clef is employed.

¹ Cf. *ibid.*, no page named [foreword].

However, it is confusing to depict the bowing on the side of the bridge, which result in sounds with indefinite pitch, by means of a bass clef whilst it is – as apparent from the example – impossible to depict minims or semibreves when using these kinds of note heads. Therefore, he employs an additional traditional note head, which makes the appearance of the score even more confusing because it is normally related to playing on the strings. Further, Lachenmann’s first method of depiction (cf. figure 69) is similar to the one employed by Holliger. But since the clef is abstracted and the note head unrelated to the requested articulation, it may be stated that it is less comprehensive. This is because it requires the player – as in the case of Lachenmann’s method of notation employed to request bowing the tailpiece (cf. figure 64) – to learn the meaning of an unrelated symbolic representation before being able to perform the articulation in an *ad hoc* situation. However, with regard to the point of contact between the bow and the bridge, Lachenmann’s second method of notation (cf. figure 70) can be described as more exact than Holliger’s approach. However, he does not employ the traditional way of requesting the *col legno battuto* and ordinary bowing, determines the duration only approximately and depicts the vertical motion by means of a special clef unless it may be notated similarly to the bow-*glissando* (cf. the previous section).

2. 5. 2. 3 Suggestion for the notation of bowing the side of the bridge

The method of notation suggested here is an elaboration of Holliger’s approach and Lachenmann’s second approach. The drawing, which is used to request the articulation, is a combination of the ones applied by the two composers. By employing such a hybrid, the articulation may be depicted in a simple way and with the greatest possible degree of instantaneous comprehension. Moreover, in order to determine the duration in a more exact way, x-shaped note heads complement the drawing. In the example

presented in figure 71, a cellist is required to perform various actions on the side of the bridge. Initially, he is supposed to execute a semiquaver *col legno battuto* on the lowest point of the bridge. Subsequently, the slit of the bridge is bowed for the duration of a minim. When doing so, a squeaky sound is produced. The player is then supposed to perform a bow-*glissando* (*glissando d'arco*), starting from the position slightly above the slit and ending on the highest point of the bridge. The *glissando* is executed for the duration of a crotchet and the highest point subsequently bowed for the duration of a dotted quaver.

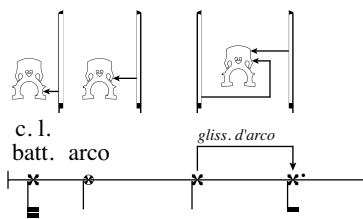

Fig. 71 Bowing the side of the bridge.

The maximum dynamic level of this articulation depends on which part of the bridge is bowed and which bowing technique is applied. A *col legno battuto* may be performed in a loud manner whilst the whistling sound may even reach the highest dynamic level. However, the *col legno tratto* or ordinary bowing of the other spots can be only executed with a low dynamic level. In the case of the *col legno battuto*, the highest dynamic levels, however, cannot be used in order to protect the *bow* and bridge. Further, the player may execute a *tremolo* motion and apply the rolling bow technique on the side of the bridge (cf. section ‘2. 3. 4 The rolling bow and its notation’ as well as section ‘2. 5. 4 Bowing the body of the instrument’ for the extended rolling bow). A similar method of notation may also be used in order to request bowing on the top or side of the

mute¹. In such a case, the drawing of the bridge would have to be simply augmented by a graphic depiction of the mute.

2.5.3 Playing the tuning pegs, peg box and scroll

When bowing the tuning pegs, peg box and scroll, slightly varying noisy sounds are produced. Additionally, it is possible to bow the strings on the nut and play *pizzicato* in the pegbox.

2.5.3.1 Previous methods of notation

Lachenmann requests to bow the scroll or tuning pegs by means of the bridge clef. In *Toccatina* he employs the full clef and gives additional directions in order to clarify which part is bowed:

Fig. 72 Lachenmann, Toccatina, p. 5.

Moreover, in *Staub* Lachenmann solely uses a detail of the full clef in order to request bowing the scroll and gives additional directions as to how the articulation should be performed:

Toneless bowing on the scroll. Draw the bow somewhat obliquely on the scroll. Remove the instrument from the chin if necessary so as to gain a better overall view of the action and to prevent the bow from slipping away.

Fig. 73 Lachenmann, Staub, no page named [foreword].

¹ Cf. Read, Contemporary, p. 212.

Further, in *Mouvement* (– vor der Erstarrung) the player is only supposed to bow on the tuning pegs and may decide by himself which peg is actually played:

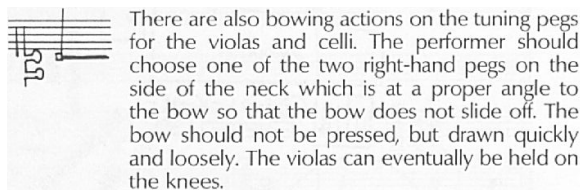

Fig. 74 Lachenmann, *Mouvement*, no page named [foreword].

Cervetti, in *Zinctum*, makes use of a special note head shaped like the pegbox and a single lined notation system with no clef in order to request bowing in between the pegs and fingerboard¹. Since the dynamic level he employs is very high, it can be assumed that not the pegbox itself, but the strings on the nut are supposed to be bowed:

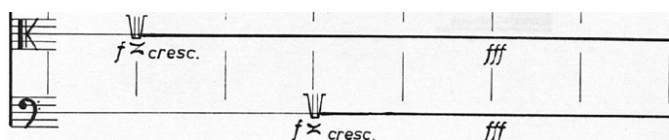

Fig. 75 Cervetti, *Zinctum*, p. 2.

Additionally, in *Klangschatten – mein Saitenspiel* Lachenmann requests to pluck the strings inside the pegbox in combination with a *pizzicato* behind the bridge. In the example presented in figure 76, a cellist is supposed to pluck the D-string in the pegbox (grace note) and subsequently behind the bridge.

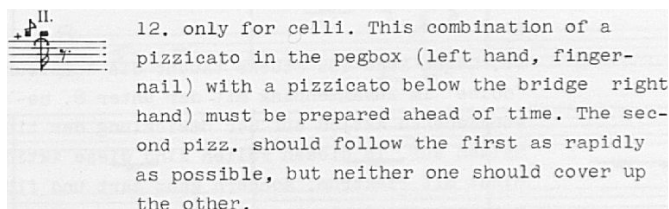

Fig. 76 Lachenmann, *Klangschatten*, no page named [foreword].

¹ Cf. Cervetti, *Zinctum*, no page named [appendix].

2. 5. 3. 2 Discussion

The articulations that involve bowing the tuning pegs and scroll resemble bowing the tailpiece. As shown in section ‘2. 5. 1 Bowing the tailpiece’, a method of notation that presents a drawing of the bow and the part that is supposed to be played, is simpler and contains a greater degree of instantaneous comprehension than the depiction by means of the bridge clef commonly utilised by Lachenmann (cf. figure 72-74). Therefore, a method similar to the one presented in figure 66 is preferred here. It may also be utilised in order to request the player to bow the pegbox when no strings are involved. Likewise, playing the strings on the nut or inside the pegbox may be compared to playing special string positions. As shown in section ‘2. 4 Extended playing positions on the string’, methods of notation that make use of a distinct note head in order to request bowing an uncommon position on the string, agree with the requirements. Cervetti indeed employs a distinct note head (cf. figure 75). However, his approach may be described as inexact since the duration is only determined approximately, the symbol he employs could not be used to depict minims and semibreves, and he does not indicate which strings are supposed to be bowed. However, the bowed strings could be depicted in a simple manner by using a special note head in combination with the string clef system. This method is also simpler than Lachenmann’s depiction of the pegbox *pizzicato* (cf. figure 76). In order to determine a uniform and clear method notation for all special string positions, the string clef system is hence chosen as the preferred method of depiction. A distinct note head can then be used to request plucking the string inside the peg box as well as bowing on the nut.

2. 5. 3. 3 Suggestion for the notation of playing the tuning pegs, peg box and scroll

The method of notation suggested for bowing the tuning pegs, peg box and scroll hence makes use of x-shaped note heads, a single lined notation system with no clef as well as a drawing of the instrument and bow. As can be seen in figure 77, the player is initially requested to bow the scroll for the duration of a minim and subsequently play on the designated tuning peg. Since a *legato* slur is used, these two positions are played with a single stroke. The player is then supposed to bow the pegbox for the duration of another crotchet. Additionally, a *tremolo* motion could be effectively performed on these parts of the instrument. It needs to be, however, noted that all articulations can be only executed with a low dynamic level.

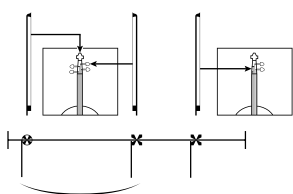

Fig. 77 Bowing the tuning pegs, peg box and scroll.

When any other spot of a string instrument is supposed to be bowed, such as the tail spike, the back of the fingerboard or the rib, the action can be depicted in the same manner and hence by means of x-shaped note heads, a single lined notation system with no clef and presenting a drawing of the particular spot (also cf. figure 95).

Further, the notation of bowing the nut and plucking the strings in the pegbox is achieved by means of the string clef system. Since the two playing positions are very close to each other and limited to the performance of two distinct articulations (*arco* on the nut and *pizzicato* in the pegbox), they can both be notated by means of the same note head and an additional direction. Because each position only occurs with its respective articulation, they may be clearly distinguished and the addition hence be

described as legitimate. As can be seen in figure 78, the note head used to depict the actions on the nut/in the pegbox is spherical. In the example a contrabassist is initially supposed to pluck the D-string in the pegbox. Subsequently, he is required to bow the E-string for the duration of a minim (down-bow), then play all four strings for the duration of a dotted crotchet (up-bow) and finally pluck the A-string.

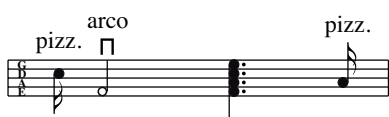

Fig. 78 Bowing the nut and *pizzicato* in the pegbox.

In the case of the *pizzicato*, only the middle strings vibrate when being plucked. The dynamic level of this articulation is low. Further, it needs to be noted that only the two outer strings may be bowed distinctly and otherwise all four (or five) strings have to be bowed at the same time. Moreover, as in the case of bowing on the bridge, the simultaneous muting of the strings is regarded here as the common way of performing this articulation (cf. section ‘2. 4. 3 Bowing on the bridge’). When the open strings are supposed to sound during, or at some point of, the articulation, the direction *lasciar vibrare* may be given. Alternatively, any other distinct note head may be utilised.

2. 5. 4 Bowing the body of the instrument

Finally, it is also possible to bow the body of the instrument. In this case, either the edges of the body, the F-holes, the ribs or the back of the body are played. This action resembles bowing the scroll, pegbox or tuning pegs. The produced noise can be described as “a weak, rather breathy sound”¹ and varies slightly according to which part of the body is played.

¹ Lachenmann, *Klangschatten*, no page named [foreword].

2.5.4.1 Previous methods of notation

Lachenmann, in *Klangschatten – mein Saitenspiel*, makes use of this technique. As can be seen in figure 79, the letter ‘C’ (as in corpus) is added to the note tail in order to request the articulation whilst “the performer should bow where it is more comfortable and where the volume of the desired toneless effect is relatively strong”¹.

The image shows a handwritten musical score for Violin I and II, measures 245-252. The score is written on ten staves. The first two staves are for Violin I (labeled 'I') and the next eight staves are for Violin II (labeled 'II'). The score includes various musical notations such as fingerings (e.g., 1-3, 4-6, 7-9, 10-12), bowings, and articulation marks. A circled '245.' is written at the top left. A performance instruction in German, 'Bogen nicht wegnehmen!', is written in a box above the Violin II staves. A note tail in the upper staff has a 'C' written next to it, indicating a specific articulation technique.

Fig. 79 Lachenmann, *Klangschatten*, p. 39.

Moreover, in *Pression* Lachenmann utilises a special system to request this articulation and gives additional directions concerning the performance, e. g. let the tip of the bow (hair) fall on the body without pressure [Bogen (Haar) an der Spitze ohne Druck auf Corpus fallen lassen] or start on the right F-hole → to the left F-hole [auf rechtem F-Loch beginnend → zum linken F-Loch]:

¹ Ibid., no page named [foreword].

The score for 'Pression' by Lachenmann is divided into four parts: I, IV, Steg, and Corpus. Part I is marked 'poco rubato' and includes a 'legno' section. Part IV is marked 'poco rubato' and includes a 'legno' section. The Steg part is marked 'sempre marcato' and includes a 'legno' section. The Corpus part is marked 'sempre marcato' and includes a 'legno' section. The score features complex rhythmic patterns with triplets and sextuplets, and specific instructions for bow pressure and placement on the instrument body.

Fig. 80 Lachenmann, *Pression*, p. 5.

Further, in ..., *den 24. xii. 1931*¹ Kagel requests a rolling bow articulation (cf. section '2. 3. 4 The rolling bow and its notation') on the body of all four string instruments by means of x-shaped note heads, a single lined notation system (with a drum clef) and an arrow added to the note tail:

The score for 'Andantino, ma poco meno mosso' by Mauricio Kagel is for four string instruments: VI, Va, Vc, and Kb. The tempo is marked 'sub.: Andantino, ma poco meno mosso (♩ = 68 - 72)'. The score includes instructions for '1/2 col legno' and 'sub.: Andantino, ma poco meno mosso (♩ = 68 - 72)'. It features x-shaped note heads and arrows on the note tails.

1) Streicher: Haarstrang gegen den Korpus pressen und Bogen einmal auf der Stelle drehen (= Geräusch, als würde die Decke bersten)
 Strings: press bow-hair against the body of the instrument, and twist the bow once on the spot (= noise as if the casing were about to burst)

Fig. 81 Kagel, 1931, p. 4.

2. 5. 4. 2 Discussion

Lachenmann's first method of notation (cf. figure 79) may be described as imprecise and hence does not agree with the second requirement. This is because he does not determine which part of the body should be bowed. However, the depiction of the body by means of the special system Lachenmann employs in *Pression* (cf. figure 80) is more

¹ Mauricio Kagel: ..., *den 24. xii. 1931*. Garbled messages for baritone and instruments. Frankfurt/M. et al. 1995.

exact even though the spot that is supposed to be played is not always exactly defined. Moreover, when comparing his directions with the notation of bowing parts of the body by means of a drawing (cf. figures 66 and 77), the graphic depiction of the bowed spots contains a greater degree of instantaneous comprehension and may be described as simpler. Further, Kagel's method of notation (cf. figure 81) is closely related to traditional notation since x-shaped note heads are, as mentioned, commonly applied to depict noisy sounds. It might be, however, confusing to add a symbol to the note tail when semi-breves are supposed to be depicted. Therefore, it is preferred here to depict the rolling bow by means of a symbol placed over the note. Further, in order to notate this articulation in a uniform manner, and because it resembles – as mentioned – a *vibrato* motion, the symbol introduced in figure 40 should also be utilised here. Moreover, Kagel does not determine the spot upon which the motion is performed. With regard to this matter, his method of notation may be, therefore, described as inexact.

2. 5. 4. 3 Suggestion for the notation of bowing the body of the instrument.

The method of notation suggested here is related to the way bowing on the tailpiece, the tuning pegs, the pegbox or scroll is depicted. It hence makes use of x-shaped note heads, a single lined notation system with no clef as well as a drawing of the body and bow. In the example presented in figure 82, a cellist is supposed to initially bow the front edge of the c-rib at the designated point for the duration of a crotchet (down-bow). Subsequently, the F-hole is bowed for the duration of a dotted quaver (up-bow). After a quaver rest the player is then supposed to perform a rolling bow articulation (*rotolato*) on the back of the instrument for the duration of a semiquaver. This request may result in a single motion. Opposed to Kagel's approach, the rolling direction is not indicated

since the sound-wise difference is negligible. After another quaver rest the back edge of the shoulder is then bowed for the duration of a crotchet (up-bow).

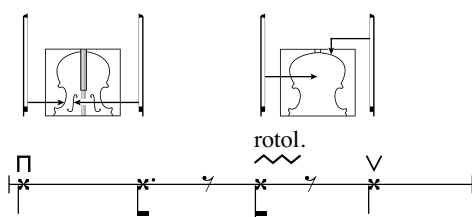

Fig. 82 Bowing the body of the instrument.

It needs to be noted that when bowing the F-hole, whistle sounds may additionally occur. Further, several other bowing techniques, such as *col arco battuto*, *gettato*, *saltando*, *balzando* or *tremolo* may be performed on the body. Additionally, the bow may be moved vertically on the edges or the back of the instrument (cf. figure 67 for an example of how such a *glissando d'arco* on the instrument may be notated). However, *col legno* techniques should not be employed when bowing on the body since they might damage the instrument. Further, the dynamic level is always very low when bowing on the body.

2. 6 Extended stopping techniques

There are two special fingering techniques explained in this section. One is to finger **half harmonic stops** and the other one to perform **exact muting stops**. Moreover, the *buzz-pizzicato* is also discussed in this section.

2.6.1 Half harmonic stops and their notation

When half harmonics are requested, the applied finger pressure is higher than when stopping harmonics and lower than in the case of fingering normal tones¹. Moreover, Lachenmann explains that it is “important not to produce any harmonics here; the result should be a veiled, almost immaterial and hardly perceptible coloring of the dominating string sound produced by the stopped note”².

This stopping technique is normally notated by means of employing a special note head, which is derived from the conventional way of depicting harmonics. For instance, Pröve employs this method in *Firebird*. As can be seen in figure 83, the note head commonly used for the notation of half harmonics is half white and half black.



Fig. 83 Pröve, *Firebird*, p. 7.

A slightly varying method is, however, utilised by Kagel in his *Streichquartett I/II*. Here an additional white and black diamond-shaped note head complements the conventional harmonic notation in order to request half harmonic pressure [1/2 Flageolettdruck] (as well as a circle to request the original harmonic fingering):

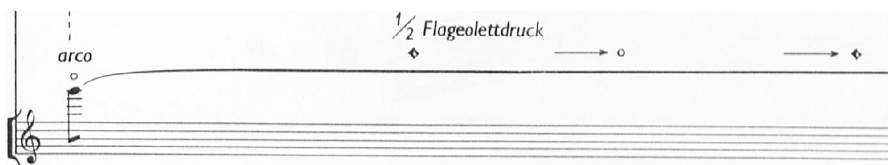

Fig. 84 Kagel, *Streichquartett I/II*, p. 31.

¹ Cf. Holliger, *Lieder*, p 16.

² Lachenmann, *Torso*, no page named [foreword].

When comparing the two methods of notation, it may be stated that both agree with the postulated requirements. However, Pröve's approach has a disadvantage since crotchets and minims would be confused with each other. Therefore, Kagel's method of using a white and black note head as a symbol that is placed over the note head is preferred here. When employing this method, it needs to be noted that half harmonic stops are not limited to the nodes and hence the natural harmonics, but may be executed on all fingerboard positions. The suggested method of notation makes use of diamond-shaped note heads to depict the stopping position and a complementary white and black diamond-shaped symbol placed above the note in order to request this articulation. Diamond-shaped note heads are employed since the fingering of half harmonic stops is rather a variation of fingering harmonics than normal tones. They are used here for all fingering positions (and hence no common note head with a small circle above it is complemented by the half harmonic symbol). As can be seen in figure 85, a violist is supposed to play a sequence of half harmonic stops, starting with a minim $e^1/E4$, followed by the four semiquavers $g/G3$, $h^1/B4$, $e/E3$, $b^1/B\flat4$ and ending with a crotchet $h/B3$. The transition from half harmonic pressure to harmonic pressure, and vice versa, could be requested by using two notes of the same pitch (one for the half harmonic and one for the harmonic stops) and connecting them by means of a *legato* slur.

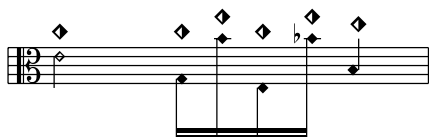

Fig. 85 Half harmonic stops.

2. 6. 2 Exact muting stops and their notation

The strings may be bowed and at the same time muted, which smothers the oscillation.

When bowing *arco*, a rough whistle sound with indefinite pitch is produced. This sound

varies when the position of the fingers is changed. When a *col legno battuto* or a *battuto* with the screw (for the latter cf. section ‘2. 3. 2 Extended *battuto* and *tratto* techniques and their notation’) is performed, a subtle pitch, which varies according to the muting position as well as the (vertical) point of impact, can be perceived. However, the effect is stronger when altering the bow position than when changing the stopping position.

Muting the strings may be requested by means of a muting sign, as suggested by Stone in his handbook on music notation:



Fig. 86 Stone, *Notation*, p. 312.

The fingering position is depicted here by means of common note heads. However, it may – as in Lachenmann’s *Toccatina* – be alternatively notated by means of diamond-shaped note heads:

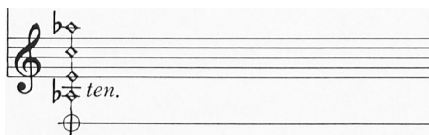

Fig. 87 Lachenmann, *Toccatina*, p. 2.

As mentioned, diamond-shaped note heads are used as the conventional method of notation for harmonics. They are utilised by Lachenmann for the depiction of muting stops because the pressure that is applied to the string is similar to when fingering harmonics. When the finger touches the string on one of its nodes, a particular partial is produced. However, when the string is fingered on an off-node position with the same pressure, it is muted. Owing to the close relationship of these techniques, it is preferred here to depict muting stops by means of diamond-shaped note heads instead of common

ones. The muting sign may complement the notation of this articulation, but does not have to be employed. This is because all necessary information is already given by explaining that the string is fingered in the same way as harmonics are fingered, but on an off-node position. Further, as opposed to Lachenmann's method of notation, it is suggested here depicting the duration of the muting stop in the traditional way. When utilising this stopping technique, all common and extended playing techniques may be applied.

Additionally, this technique may be further extended by attaching the fingernail, instead of the tip of the finger, to the string. When doing so, the string may either be bowed or plucked. In the case of the *pizzicato*, this articulation is referred to as a one variant of the **buzz-pizzicato**. There are three ways of creating it: 1. By slightly touching the lingering string with the right hand's fingernail after a *pizzicato*. 2. By slightly touching the lingering string with the left hand's fingertip after a *pizzicato*. 3. By slightly touching the string with the left hand's fingernail during the performance of a *pizzicato*. In the case of variants 1 and 2, a *pizzicato*-sound is followed by a buzzing whilst in the case of variant 3, a *pizzicato*-sound and buzzing blend¹.

Sevsay suggests a symbol resembling the one representing a *Bartók pizzicato* (⊖) for the notation of variant 1 and explains that, in the case of the other two variants, a pre-defined symbol or verbal explanation should be used². Moreover, Cerha, in *Enjambements*³, makes use of variant 3 and combines a symbol he uses to request the common *pizzicato* articulation with the letter 'N' (as the German *Nagel* or nail) in order to depict it:

¹ Sevsay, Handbuch, p. 64.

² Cf. *ibid.*, p. 64.

³ Friedrich Cerha: *Enjambement*. [For flute, violin, percussion, trumpet, trombone and double bass]. Vienna 1963.

 = fingernail (left hand) placed on the string, right hand pizzicato (occurs only on the E-string)

Fig. 88 Cerha, Enjambements, no page named [foreword].

Concerning the method of notation presented by Sevsay, it can be said that despite being valid with regard to the requirements, it might be irritating to employ the pictured symbol for an articulation that is not related to a *Bartók pizzicato*. As shown above, there is another *pizzicato* articulation (which is in section ‘2. 1 Extended *pizzicato* techniques and their notation’ referred to as the lateral *Bartók pizzicato*) that deserves rather to be requested by means of this symbol. Moreover, Cerha’s method of notation violates the third requirement since the traditionally utilised method of depicting the *pizzicato* is replaced by a sign shaped like a fingernail symbol (cf. figure 4). However, it would generally be valid to request the *buzz-pizzicato* by means of a symbol. But such a method would have to be complemented by a depiction of the fingering position.

Since none of these examples can be adequately utilised for the depiction of all *buzz-pizzicato* variants, another method needs to be developed. As mentioned, there are three variants of this technique. In the case of the first one, the right hand touches the string and, in the case of the second and third one, the left hand performs this action. The first variant is strongly related to the *col legno toccato* (cf. figure 38). Here the string is, however, not touched with the bow’s wood, but the right hand’s fingernail. Nevertheless, it may be notated by giving the direction *toccato* and employing an additional fingernail symbol. Moreover, the method of notation suggested for the second and third variant is related to a *col legno toccato* on the fingerboard. This is because in the case of these *buzz-pizzicati* the player acts similarly to when touching the string with the bow’s wood on the fingerboard. However, since only the left hand is involved in this action, no additional notation system needs to be employed. Therefore, this articulation can be

notated by means of diamond-shaped note heads complemented by the direction *toccato* and – if necessary – a fingernail symbol.

The first and second variant of the *buzz-pizzicato* consists of two distinct actions and is, therefore, notated by means of two note heads. In figure 89 the actions are performed on the D-string of a violin, and all three variants of the *buzz-pizzicato* are displayed:

1. The instrumentalist plays a demisemi-quaver *pizzicato sul tasto f^l/F4* and subsequently touches the string with the right hand's fingernail on the *sul tasto* position for the duration of a semi-quaver. The *legato* slur underlines that the finger is not released, but the player constantly stops the same tone and additionally touches the string after a demisemi-quaver.
2. The player performs a *pizzicato f^l/F4* and subsequently touches the string with the left hand's fingernail on position *g^l/G4* for the duration of a semi-quaver. The *legato* slur emphasises that the *f^l/F4* is again constantly fingered and the string is additionally touched after a demisemi-quaver.
3. The player performs a *pizzicato*. At the same time, he stops an *f^l/F4* and touches the string with the left hand's fingernail on position *g^l/G4*. The direction *pizzicato e toccato* is used – instead of merely depicting a fingernail muting stop that is plucked – in order to outline that a fingernail *pizzicato* is not supposed to be executed, but a fingernail *toccato*.

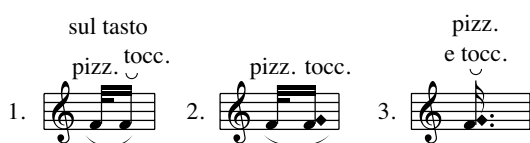

Fig. 89 The three variants of the *buzz-pizzicato*.

2.7 Percussive effects

Percussive effects can either be produced **on the body** (including other parts, such as the tuning pegs) of the instrument or **on the strings**. When requested, the player is supposed to hit the designated spot with knuckles, the flat of the hand or single fingers.

2.7.1 Strokes on the body and their notation

When hitting the body of the instrument, a “mellow, hollow”¹ sound is produced. It varies according to which spot of the body is struck and which part of the hand is used for the performance of the percussive effect. This articulation is often requested by means of x-shaped note heads, a single lined notation system with no clef and an additional direction². An example for such a method of notation can be, as apparent from figure 90, found in Kagel’s *Match*.

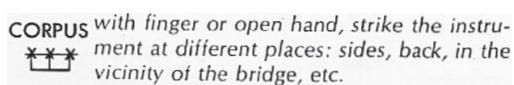

Fig. 90 Kagel, *Match*, p. 5.

A similar method is utilised by Xenakis, in *ST/4-1,080262*. He employs an x-shaped note head in a pitch-based notation system and gives the direction *table*³ (French for body):

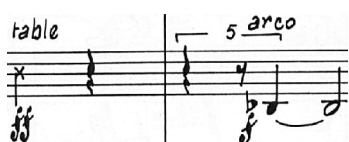

Fig. 91 Xenakis, *ST/4-1,080262*, p. 9

However, the two methods may be described as imprecise since neither the exact point of impact nor the part of the hand which performs the strike is precisely determined. Further, employing an x-shaped note head in a pitch-based notation system suggests that pitch is produced. However, strokes on the body only produce noises, unless the strings are not muted (see below). In order to fulfil the postulated requirement

¹ Crumb, *Echoes*, p. 17.

² Cf. Cerha, *Enjambements*, p. D₂ or Crumb, *Echoes*, p. 17.

³ Cf. Xenakis, *ST/4-1,080262*, p. 1.

of exactness, the methods of notation need to be further elaborated. This elaboration is, as Kagel's approach, based on the utilisation of x-shaped note heads and a single lined notation system with no clef. This is because sounds with indefinite pitch are, as mentioned, commonly notated in this way. Moreover, since the action of hitting the body resembles the action of bowing the body (see section '2. 5. 4 Bowing the body of the instrument' for further details), it may be notated in the same way. A drawing of the instrument's body, which enables the determination of the point of impact, is hence combined here with a drawing of the player's hand. This sound producer may be employed in various ways. The knuckles, the side of the fist, the palm, single fingers and finger tips (with or without involving the fingernails) may be used to strike the body. In figure 92 the drawings utilised to request a stroke with 1. the knuckles and 2. the side of the fist are presented.



Fig. 92 The knuckles and the side of the fist.

Moreover, another drawing needs to be applied in order to determine whether the instrument should be struck with the palm, single fingers or the finger tips. As can be seen in figure 93, the part of the hand that is supposed to be utilised is always coloured black. The drawings are in this example presented in the order of a stroke with 1. the palm, 2. the index, middle and ring finger, 3. the tip of the thumb, index and middle finger and 4. the tip and fingernail of the index finger¹. The fingernail is depicted by means of a symbol derived from Lachenmann's fingernail symbol (cf. figure 4).

¹ The drawings from figure 92f. were created with the help of the *Hand Sign* font by *Sam Wang*.



Fig. 93 Parts of the hand.

The exact spot that is supposed to be struck is indicated by a black dot placed on the drawing of the instrument. In the example presented in figure 94, six different strokes are performed on various parts of a contrabass. They are executed in the order of 1. with the knuckles on the right upper front, 2. with the side of the fist on the left upper front, 3. with the palm on the right lower back, 4. with the index, middle and ring finger on the right lower front, 5. with the tip of the thumb, index and middle finger on the right lower front, 6. with the tip and fingernail of the index finger on the left upper back (out of the player's perspective). All actions are separated by quaver rests.

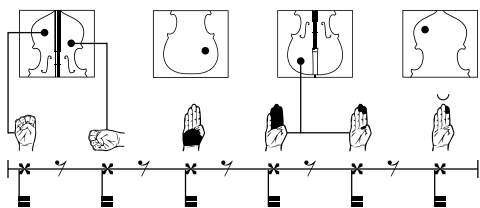

Fig. 94 Strokes on the body.

When single fingers are supposed to be used in fast succession, the order can be additionally depicted as on the piano, e. g. 4, 3, 1, 4, 0, 5 (also cf. the *pizzicato tremolo* in section '2. 1 Extended *pizzicato* techniques and their notation'). Further, complex rubbing motions can also be executed on the body (cf. section '4. 2. 4 Rubbing and bowing motions'). Further, other parts of the instrument, such as the tailpiece, bridge, scroll, pegbox or tuning pegs may be struck. These actions may be requested by employing a drawing of the respective part (cf. sections '2. 5. 1 Bowing the tailpiece', '2. 5. 2 Bowing the side of the bridge' and '2. 5. 3 Playing the tuning pegs, peg box and

scroll’). Additionally, the side of the body may also be struck. This part of the string instrument may be depicted by means a drawing similar to the one presented in figure 20 (or by means of a variation of such a drawing when depicting a violin or viola):

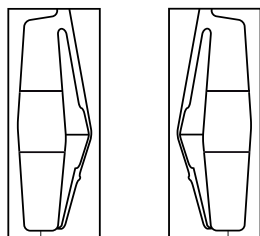

Fig. 95 The right and left side of a violincello/contrabass.

Moreover, muting the strings during the execution of the strokes is regarded here as the common way of applying the articulation (except for when the player is supposed to simultaneously hit the instrument with both hands). When the open strings are supposed to sound during or after the articulation (including after the two-handed hit), the direction *lasciar vibrare* may be given. In order to prevent the instrument from being damaged, the dynamic level, and hence the applied force, needs to be low. Therefore, it is also not possible to scratch the instrument’s body with the fingernails or, as mentioned, bow or hit it *col legno*.

2.7.2 Strokes on the strings and their notation

When the strings are struck sharply with the hand and simultaneously muted, only the percussive sound of the stroke may be perceived. This kind of attack is principally a hybrid of an extended technique of percussion instruments – referred to as the stop attack or dead stroke – and a *battuto* on the fingerboard/with the left hand (cf. figure 32 and 35). Owing to the strong relationship of strokes on the strings to these articulations, a discussion of previous methods of notation is dismissed here, but instead a suggestion

presented which complies with the methods of notation for the described techniques: as it is shown in section ‘4. 4. 3 The stop attack and its notation’, dead strokes may be depicted by utilising a symbol of the beater and a muting sign (\oplus). Because the stop attack on percussion instruments and the strokes on the strings strongly resemble each other, the method of notation may be transferred from percussion to string instruments. Here the beater is the hand (cf. the previous section). However, in the case of string instruments, the point of impact on the string needs to be determined differently. As shown above, all actions on the fingerboard – which do not imply that the string is completely depressed on the fingerboard – are depicted by means of diamond-shaped note heads. This method of notation can also be applied to the strokes on the strings because the strings are, in this case, not depressed either. Further, when strokes on the ordinary playing positions are supposed to be executed, common note heads that depict the string (by taking the example of the violin, by means of the pitches $e^2/E5$, $a^1/A4$, $d^1/D4$ and/or $g/G3$) need to be employed and the additional direction *sul tasto*, *ordinario* or *sul ponticello* be given. This is because an action of this kind resembles the performance of any kind of bowing motion on the ordinary playing positions with open strings. Additionally, it should be outlined which hand is used to execute the stroke.

In figure 96 a violinist is supposed to perform a stop attack on the position $f^1 - c^2 - g^2 - d^3/F4 - C5 - G5 - D6$, using the index, middle, ring and little finger of his left hand (*mano sinistra*). The second hit is executed on the same position, but now with the palm. Subsequently, all strings are hit with the right hand’s (*mano destra*) knuckles on the *sul tasto* position and finally on the *sul ponticello* position.

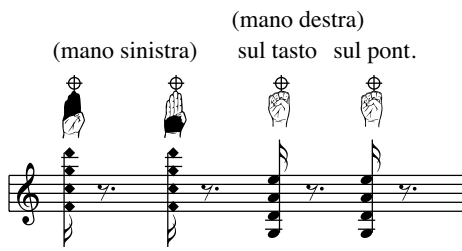

Fig. 96 Stop attack with the hand.

Sounds with a higher dynamic level than in the case of the strokes on the body may be produced when executing stop attacks with the hand on the strings. However, the fingernails cannot be employed and only the right hand's knuckles and side of the fist may be comfortably utilised for the execution of such strokes. But when previously placing down the bow, the player may also use all other parts of the hand. Another percussive effect is produced by **striking the fingerboard** between the strings with single fingers. This articulation can be requested in the same way as the action of scratching the fingerboard and hence by the additional direction *il tasto* and diamond-shaped note heads (cf. figure 10). Since the fingerboard is more resistant than the body, higher dynamic levels may be, in this case, produced.

Furthermore, in the case of executing dead strokes with the hand, it does not make a difference whether the strings are additionally muted with the other hand or not because they do not vibrate subsequently to the stroke. However, when using a beater or the wood of the bow, the strings linger after the attack. Therefore, the notation becomes more complex. As it is shown in the chapter on percussion instruments, beaters are normally depicted by means of symbols. When using the bow as a beater, no symbol, but the direction *col legno battuto* is conventionally employed. A stop attack can also be performed with the wood of the bow when it remains firmly in contact with the string after the attack. Eight different types of dead stroke articulations may be performed: a stroke on the ordinary bowing positions with 1. open strings, 2. depressed strings,

3. muted strings, 4. harmonic fingering and a stroke on a fingerboard position with 1. open strings, 2. depressed strings, 3. muted strings, 4. harmonic fingering. In order to notate these attacks, the paradigms presented in section ‘2. 6. 2 Exact muting stops and their notation’ (for the depiction of strokes with muted strings) and figure 32 (for the depiction of the ‘bowing’ on the fingerboard) need to be employed. In the example presented in figure 97, the eight types of stop attacks, executed with the wood of the bow, are displayed in the order of a stroke on the position *ordinario* 1. with open G-string, 2. whilst depressing the string on position *a/A3*, 3. whilst muting the string on position *a/A3*, 4. whilst fingering the second partial and, further, a stroke on the fingerboard position *f^l/F4* 1. with open G-string, 2. whilst depressing the string on position *a/A3*, 3. whilst muting the string on position *a/A3*, 4. whilst fingering the second partial.

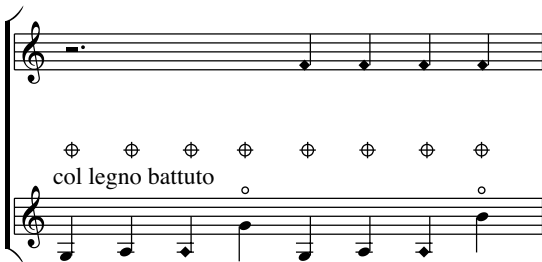

Fig. 97 Stop attack with the wood of the bow.

In the case of utilising a beater, the direction *col legno battuto* may be simply replaced by the beater symbol. Furthermore, the strings may also be struck in the same way as the common *col legno battuto* is performed with the hand or a beater. In such a case, it also makes a difference whether the strings are open, depressed, muted or a harmonic fingering is used. Such an attack may be notated by replacing the direction *col legno battuto* with the beater symbol and not employing the muting sign. Hence the paradigms used for the depiction of the conventional and extended *col legno battuto* on

the fingerboard (cf. section ‘2. 3. 2 Extended *battuto* and *tratto* techniques and their notation’) need to be simply transferred to the usage of a beater. Moreover, various other attacks, such as normal strokes, *pizzicati*, harmonic-*glissandi* etc. may be executed by means of beaters. Because these playing techniques are, however, primarily used on the harp, they are discussed in section ‘5. 4. 3 The utilisation of beaters and its notation’.

2. 8 Preparing the instrument and its notation

There are numerous ways of preparing string instruments. It is, on the one hand, barely possible to list them all and subsequently develop a coherent method of depiction whilst, on the other hand, it is also not necessary to do so since most preparations are executed previously to a performance and may be simply described in the foreword to a work. However, when preparations are supposed to be performed during a concert, they become in some sense an extended playing technique. Because there are manifold ways to manipulate the instrument, only a few examples can be presented here.

An extended utilisation of the bow – designated as ‘curved bow or ‘loosen the bow’ – is employed by Holliger in *Duo II*. In order to request it, he gives the following explanation: “[b]ow stick below and hairs above the violin: evenly over four strings”¹. Subsequently, the player is required to bow all four strings simultaneously. Further, in the same piece Holliger also makes the player attach a length of string to the G-string of a violin. This time the explanation is complemented by a sketch:

¹ Holliger, *Duo II*, p. 13.

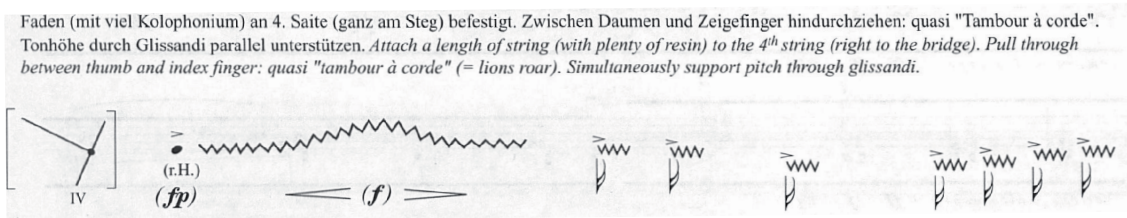

Fig. 98 Holliger, Duo II, p. 13.

Various examples of preparations can also be found in Kagel's *Streichquartett I/III*. All requisites and materials he utilises are listed in the foreword of the work. As can be seen in figure 99, one example of a preparation is to place a knitting needle (made of metal) [Stricknadel (aus Metall)] in between the strings. The needle is supposed to be attached on the string position 10¹. Kagel explains this preparation by means of a sketch:

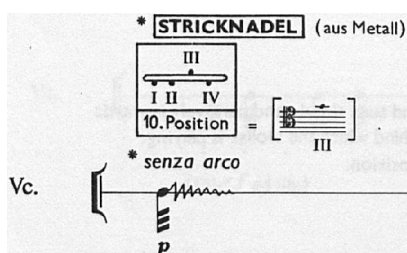

Fig. 99 Kagel, Streichquartett, p. 1.

Further, Kagel also makes a cellist attach sticky tape [Klebefilm] to the ordinary bowing position on all four strings. He again depicts this action by means of a sketch:

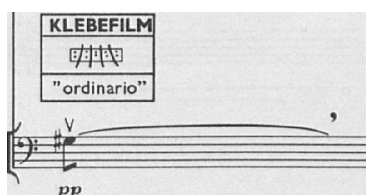

Fig. 100 Kagel, Streichquartett I/II, p. 20.

¹ Kagel depicts a g^1/G^4 in the example and states that this is the 10. position on the G-string (III) of a violincello. Position no. 10 on the G-string would, however, be depicted by an f/F^3 . Therefore, it is assumed that the 10. position on the A-string (I) is depicted and the wrong numeral used.

As apparent from these examples, the simplest way of explaining the preparations that are supposed to be carried out is to use a sketch. When the sketch is not clear enough it may be complemented by an explanation (cf. figure 98). Hence a simpler method of depiction for Holliger's so-called 'curved bow' would be to present an additional drawing of the preparation's outcome. When disregarding this example, all presented approaches towards the depiction of preparations comply with the postulated requirements. They are exact, simple and may be used to augment the traditional notation system. Therefore, it is suggested here presenting any preparation that is supposed to take place during the course of a piece, by means of a sketch and – if necessary – an additional explanation. Nevertheless, preparations may – as apparent from figure 98 – lead to the introduction of new playing techniques that should then be notated in accordance with all other techniques presented in this work.

2.9 Rare extended playing techniques and their notation

There are a few more rare playing techniques that are discussed here separately. One is to **hold the bow under the strings** and perform simple playing techniques, such as *col arco* or *col legno battuto/tratto*. This action may either be performed in between fingerboard and bridge or behind the bridge. When the bow is held in this way, the two outer strings may be played simultaneously, but the middle strings cannot be played at all.

Lachenmann, in *Gran torso*, makes use of this articulation. A cellist is supposed here to place the bow under the strings [Bogen unter den Saiten] in between fingerboard and bridge. Subsequently, he is required to perform a *col legno battuto* on the muted A-string. The position of the bow is explained by means of a sketch. Additionally, a

squared note head and a note tail complemented by an arrow pointing upwards is utilised to depict the *battuto*:



Fig. 101 Lachenmann, Torso, p. 14.

Since this articulation is very uncommon, it does make sense to notate it by presenting a sketch and giving an additional explanation. However, because the technique is at the same time closely related to ordinary playing techniques, there is no need to utilise a special note head and tail. Therefore, it is suggested here introducing this articulation by means of a sketch similar to the one presented by Lachenmann and an explanation, such as *arco sotto la corda* (bow underneath the string), but then notate the playing action in the normal way. In the case of playing in between fingerboard and bridge, the notes may be complemented by indicating that the action takes place underneath particular strings. In the case of the violincello, the directions *sotto A e C*, *sotto A* or *sotto C* could be employed.

As can be seen in figure 102, a cellist is supposed to initially bow the A- and C-string *sul ponticello* whilst stopping the chord $D - c^1/D2 - C4$ for the duration of a minim. After a dotted quaver rest, a *col legno battuto sul tasto* is performed on the C-string whilst fingering a $d/D3$. Finally, the player is requested to execute a *col legno tratto sul tasto* on the A- and C-string while stopping the chord $E - c^1/E2 - C4$ for the duration of a crotchet. The utilisation of the bow in the normal way is then requested by the direction *arco sulla corda*.



Fig. 102 Playing under the strings in between fingerboard and bridge.

Playing under the strings behind the bridge may be notated similarly. The action of placing the bow underneath the string should again be explained by means of a sketch. Subsequently, the suggested method of notation for playing behind the bridge – and hence x-shaped note heads and the string clef system – may be employed (cf. section ‘2. 4. 4 Playing behind the bridge’). The indication *sotto A e C* etc. is replaced here by simply leaving the spaces that normally represent the middle strings blank.

In figure 103 the player is at first supposed to bow the A- and C-string *sul ponticello* for the duration of a minim. After a dotted quaver rest, a *col legno battuto sulla cordiera* is then performed on the C-string. Finally, the player is requested to execute a *col legno tratto sulla cordiera* on the A- and C-string. Afterwards, the bow is supposed to be utilised in the normal way.

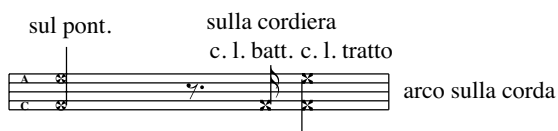

Fig. 103 Playing under the strings behind the bridge.

When bowing under the strings behind the bridge, it is possible to further transform the sound by attaching the fingers to the string. This technique may also be notated by transferring the paradigm presented in section ‘2. 4. 5 Fingering behind the bridge and its notation’. Generally, bowing underneath the strings may be executed with all possi-

ble dynamic levels. However, the *col legno battuto* may be only performed with a low dynamic level.

Another extraordinary articulation is to **scratch on the fabric covering of the strings** with the fingernail. Holliger, in *Duo II*, requests this action by means of a fingernail symbol, an additional explanation, a wavy line and *de-/crescendo* symbols:

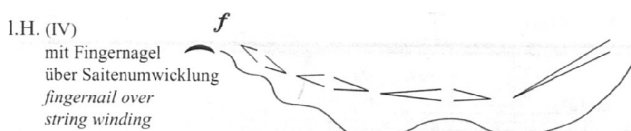

Fig. 104 Holliger, *Duo II*, p. 20.

However, this method of notation is, as obvious, very imprecise since exact durations are not determined. Further, because he makes use of a long explanation, the degree of instantaneous comprehension is very small. For these reasons, a further elaborated method of notation is suggested here. It involves – as in the case of executing strokes on the body – a drawing of the sound producer (cf. figure 94). However, this time the hand is not used for the performance of a stroke, but to scratch on the string, which is expressed by an additional direction. Since the positioning of the finger is similar to when bowing *sulla cordiera* behind the bridge, x-shaped note heads and the string clef system may be employed to depict this articulation. As can be seen in figure 105, a violinist is supposed to scratch on the string winding of the D-string with the tip of his index finger whilst involving the fingernail for the duration of a semibreve. The dynamic level of this articulation is always very low.

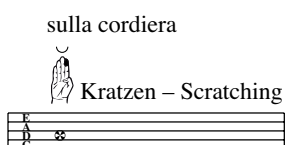

Fig. 105 Scratching *sulla cordiera*.

Finally, Kagel requests a cellist to **blow into one of the F-holes** of his instrument by means of a symbol that represents the holes and the following explanation: “BLOWING: Raise the cello and blow into one of the sound-holes in such a way that a highly resonant sound results. Meanwhile, move the instrument slightly, thereby producing continual changes of timbre”¹:

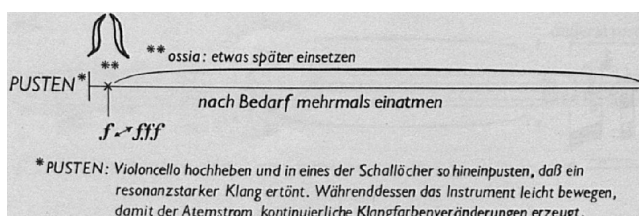

Fig. 106 Kagel, Streichquartett I/II, p. 32.

However, Kagel’s method of notation is quite unclear and imprecise. This is because the symbol he employs does not clearly depict the action that is supposed to be performed, an additional long explanation is necessary and it is not indicated when the so-called changes in timbre are supposed to be performed. Further, the action of blowing into the instrument resembles other articulations that are executed on the body. As shown in sections ‘2. 5. 4 Bowing the body of the instrument’ and ‘2. 7. 1 Strokes on the body and their notation’, the preferred method of notation for such effects is to present a drawing of the instrument and the sound producer. Nevertheless, the notation of the duration by means of x-shaped note heads and a single lined notation system with no clef is adequate since the produced sound has an indefinite pitch.

Therefore, the method of notation suggested here makes use of x-shaped note heads, a single lined notation system with no clef as well as drawings of the instrument and sound producer. As can be seen in figure 107, the exact point of ‘embouchure’ is indicated by arrows and the motion up and down the F-hole in reference to the bow-

¹ Kagel, Streichquartett I/II, p. 32.

glissando on the body designated as a *glissando della bocca* (mouth *glissando*). In the example a cellist is supposed to start blowing the lowest point of the F-hole and then gradually change the point of embouchure for the duration of a minim until the highest point is reached. Subsequently, the mouth is again moved downwards for the duration of a crotchet. Then the player blows the lowest point of the F-hole for the duration of another crotchet.

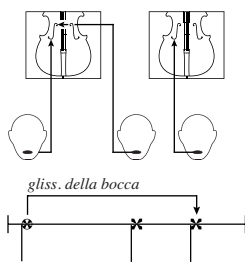

Fig. 107 Blowing into the instrument.

In order to clearly outline what kind of action the player is supposed to execute, it may be useful to present an additional short explanation such as ‘blowing into the F-holes’, at the first occurrence of this articulation. Moreover, the dynamic level requested by Kagel (*forte* and *forte fortissimo*) is impossible to be produced by blowing into the sound-holes. On the contrary, the loudness of this articulation is actually always low.

Furthermore, any other rare extended playing technique, which has not been taken into consideration here, should be depicted in accordance with the methods of notation suggested in the previous sections. Additionally, some of the playing techniques discussed in the chapter on plucked instruments may be also applied on string instruments (cf., for instance, section ‘5. 1 Extended *pizzicato*, *tremolo* and trill techniques and their notation’ or ‘5. 4. 5 Strumming and its notation’). They are not discussed here because they are primarily plucked instruments’ techniques.

2.10 Summary

In this part of the work the unconventional playing techniques of string instruments are introduced, their previous methods of notation discussed and suggestions for their notation presented. In the first section extended *pizzicato* techniques, including the left hand *pizzicato*, the fingernail *pizzicato*, *pizzicato* tremolo, plectrum *pizzicato*, bow-screw *pizzicato*, *pizzicato* with items – such as a nail file or pencil – and the lateral *Bartók pizzicato* – which refers to pulling the lowest string to the side – are discussed. The next section then focuses on extended *glissando* techniques. These are the harmonic-*glissando* without bowing and the bow-*glissando*. When the harmonic-*glissando* is requested, the player is supposed to slide – quasi *flageolet* – up and down on the string with the left hand. Because the motion is performed without any additional bowing, only the noise that is produced by the fingers sliding on the string can be perceived. Moreover, the player may also scratch the fingerboard or perform a harmonic-*glissando* with items, such as a sponge or bottleneck. Further, in the case of requesting a bow-*glissando*, the player is supposed to move the bow vertically on the string. This motion can be executed with or without normal (horizontal) bowing and on the common bowing positions as well as on the fingerboard (the extended bow-*glissando*). Further, the bow-*glissando* may also be executed behind the fingerboard of violincellos or contrabasses.

In the section on extended bowing techniques the exaggerated bow pressure, extended *battuto* and *tratto* techniques, the articulations *saltando*, *balzando* and *toccato* as well as the rolling bow is discussed. When requesting exaggerated bow pressure, the player is supposed to increase the string tension, which results in a rough and noisy sound. Further, there are a number of extended *battuto* and *tratto* techniques. The most common ones are to either apply the bow's hair and wood simultaneously or to execute

a *battuto* with the hair. Additionally, the *battuto* may be executed with the screw or items as well as with the left hand on the fingerboard (tapping). Moreover, the *saltando* may be described as a dense shake of the bow after striking the string, which does not imply any horizontal motion and the *balzando* as a bouncing of the bow on the string by its own weight. Both actions may be performed *col arco* and *col legno*. However, the *toccato* may be only executed *col legno* and be described as touching the string gently with the bow's wood. A sound effect is achieved when the previously struck string is still vibrating. Further, the *toccato* may be executed with the screw of the bow or items. Finally, the rolling bow refers to attaching the bow to the string and pressing the wood of the bow into the hair of the bow. When a rolling motion is then executed, a dryly crackling grinding is produced. The next section is devoted to extended playing positions on the string and hence the depiction of the highest possible tone, fingering in between fingerboard and bridge, bowing on the bridge, playing behind the bridge/on the tailpiece and fingering behind the bridge. Besides the highest possible tone, the highest possible harmonic may be requested on string instruments. Moreover, when the hand leaves the fingerboard and moves into the space between fingerboard and bridge, sounds with indefinite pitch are produced. Further, bowing on the bridge may be requested as a distinct articulation or be combined with bowing an extreme *sul ponticello* position. When playing behind the bridge, squeaky sounds with indefinite pitch evolve. This sound can be further transformed by attaching the fingers to the strings.

The section on playing exceptional spots then concentrates on bowing the tailpiece itself, the side of the bridge, the tuning pegs, peg box and scroll as well as the body of the instrument. Moreover, the technique of bowing the nut and plucking the strings in the pegbox is also discussed there. The following section then focuses on extended stopping techniques, including half harmonic stops and exact muting stops. When

requesting half harmonic stops, the applied finger pressure is higher than when stopping harmonics and lower than in the case of fingering normal tones. Moreover, exact muting stops refer to fingering off-node positions whilst bowing the string. This technique may be further extended by using the fingernail instead of the bow to mute the string during the performance of a *pizzicato* and then be described as one variant of the buzz-*pizzicato*. The other variants are to slightly touch the lingering string with the right/left hand's fingernail or the fingertip after a *pizzicato*. Furthermore, in the section on percussive effects the execution of strokes on the body or other parts of the instrument as well as on the string are discussed. In the case of striking the body, the sound varies according to which spot of the body is struck and which part of the hand is used. Moreover, percussive effects on the strings may be produced by striking the strings sharply with the hand and simultaneously muting them. These kinds of strokes can be described as stop attacks and may alternatively also be executed by means of the bow's wood or beaters. In such cases, the strings may be additionally fingered because they vibrate subsequently to the hit. Further, the next section focuses on the preparation of string instruments and displays some of the preparations that may result in new playing techniques being created. Finally, a few more rare extended playing techniques are discussed separately. They can be described as holding the bow under the strings and executing simple playing techniques, scratching on the fabric covering of the strings with the fingernail or blowing into the F-holes.

3. THE TECHNIQUES OF WIND INSTRUMENTS

There are two groups of wind instruments, woodwinds and brass instruments. Woodwinds are, inter alia due to their distinct sound character and timbre, considered to be a heterogeneous group, which includes flutes, oboes, bassoons, clarinets and saxophones. However, brass instruments may be regarded as a rather homogeneous group. Horns, trumpets, trombones and tubas belong to this family of instruments¹. Despite their different character, many extended playing techniques may be, however, produced on both – woodwinds and brass instruments – in the same manner. Therefore, this chapter is not divided into two parts or single instruments, but solely grouped by unconventional extended playing techniques. In the beginning of each section it is indicated if a special technique may not be executed on a particular instrument.

Moreover, this chapter mainly focuses on the most common wind instruments, including the flutes, oboes, the bassoon, the clarinets, the F horn, C trumpet, tenor trombone and the bass tubas. When employing rather uncommon instruments, such as the recorder, double bassoon, flügelhorn, cornet, bass trombone or contrabass tuba, the methods of notation may be, in most cases, simply transferred because the more common instruments resemble these. With regard to wind instruments, the notation of the basic *vibrato* and the basic trill (including double trills), the basic (fingered) *glissando*, the common playing techniques (including single-, double- and triple-tonguing), extended ranges, harmonics (including double harmonics) and circular breathing as well as clusters (also cf. section ‘6. 6. 1 Clusters’) and multiphonics are regarded here as conventional². Their notation can be accessed through the essential handbooks on instrumentation whilst most composers use the method of depiction that can be found there.

¹ Sevsay, Handbuch, pp. 90, 94 and 107.

² Cf. Sevsay, Handbuch, pp. 134-148 as well as the handbooks mentioned below.

In the case of the *vibrato*, it needs to be noted that, for instance, three types of bassoon *vibrati* may be produced, the diaphragm vibrato, the lip vibrato and the so-called *smorzato*¹. The latter articulation may be described as an oscillating change of, firstly, the volume and, secondly, the timbre without altering the pitch². It is thus strictly speaking not a *vibrato*, but nevertheless normally referred to as a *vibrato* variant³ and discussed in the following section. All other *vibrato* variants may be notated by means of the *vibrato* symbol and giving an additional direction, such as *vibrato di diaframma* (diaphragm vibrato) or *vibrato di labbro* (lip vibrato). Further, fingering charts for multiphonics and microtones on the woodwinds are presented in Levine and Mitropoulos-Bott^{4/5} for the flutes, in Peter Veale et al.⁶ for the oboes, in Rehfeldt⁷ for the clarinets and in Krassnitzer⁸ for the German B \flat clarinet, in Gallois⁹ for the bassoon as well as in Weiss and Netti¹⁰ or Kientzy¹¹ for the saxophones. When applying these techniques, one will have to simply use the charts presented within these works in a uniform way. When no such book is yet available for a particular instrument, multiphonics may be only used in an approximate way by indicating the fundamental upon which the chord is supposed to be produced. Alternatively, charts may be created in cooperation with the players.

¹ Gallois, Bassoon, p. 59.

² Peter Veale et al.: The techniques of oboe playing. Kassel et al. 1994, p. 137.

³ Carin Levine and Christina Mitropoulos-Bott: The techniques of flute playing. Kassel et al. 2002, p. 33.

⁴ Ibid.

⁵ Carin Levine and Christina Mitropoulos-Bott: The techniques of flute playing II. Piccolo, alto and bass flute. Kassel et al. 2004.

⁶ Veale, Oboe.

⁷ Phillip Rehfeldt: New directions for clarinet. Los Angeles and London 1977.

⁸ Gerhard Krassnitzer: Multiphonics für Klarinette mit deutschem System und andere erweiterte Spieltechniken [Multiphonics for clarinets with German system and other contemporary playing techniques]. Aachen 2002.

⁹ Gallois, Bassoon.

¹⁰ Marcus Weiss and Giorgio Netti: The techniques of saxophone playing. Kassel et al. 2010.

¹¹ Daniel Kientzy: Les sons multiples aux saxophones [Multiphonics on saxophones]. For soprano, soprano, alto, tenor and baritone saxophones. Paris 1982.

Further, as already explained in the introduction to the chapter on string instruments, microtones are not specifically addressed in this work while the main unconventional elements of sound production discussed in this chapter are extended *vibrato*, *tremolo* and trill techniques, extended tongue and embouchure techniques, the pitch bending articulation, extended blowing techniques, preparing the instrument, whistle techniques, muting, percussive effects and resonance effects. Concerning the dynamic level of these articulations, indications are – as far as possible – presented when the execution of the action is in terms of the loudness limited.

3. 1 Extended *vibrato*, *tremolo* and trill techniques and their notation

The *smorzato* articulation has been introduced in the previous section. As mentioned, it implies an oscillating change of the amplitude and timbre. Therefore, the *smorzato* may be described as a *tremolo* (amplitude modulation) and overtone *vibrato* (frequency modulation) hybrid. This effect can be executed on the woodwinds. The saxophone *smorzato* can be, for instance, produced in two ways, with movements in the jaw or diaphragm accents¹ (please confer for diaphragm accents also section ‘3. 5. 3 The air and tone technique’), the bassoon *smorzato* by strong pressure of the jaw and lips on the reed² or the flute *smorzato* by a fast upward and downward movements of the upper and lower lips³.

Bartolozzi suggests notating this effect by means of a special note head⁴. The one he employs is circular and always white. Additionally, he indicates that there is no fixed rhythm [rhythmisch frei]:

¹ Weiss and Netti, *Saxophone*, p. 151.

² Gallois, *Bassoon*, p. 51.

³ Levine and Mitropoulos-Bott, *Flute*, p. 33.

⁴ Cf. Bruno Bartolozzi: *Neue Klänge für Holzblasinstrumente* [New sounds for woodwinds]. Mainz 1971, pp. 26f., 70f. and 76.

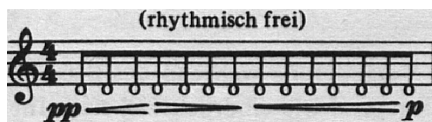

Fig. 108 Bartolozzi, Klänge, p. 27.

Moreover, Ferneyhough, in *Mnemosyne*¹, makes use of waved lines, as utilised for the *vibrato* notation, a *tremolo* symbol and the direction *smorzato aperiodico* in order to request an irregular *smorzato*. Moreover, he utilises spatial notation to emphasise the aperiodic character of the articulation:

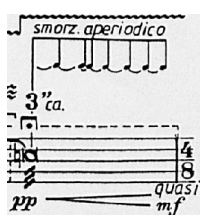

Fig. 109 Ferneyhough, Mnemosyne, p. 1.

When compared, Ferneyhough's method of notation is preferred here. This is because Bartolozzi's approach is confusing as he employs single notes for an articulation that is continuous and depicts a rhythm whilst determining that there is no such thing. Further, Ferneyhough's method of notation may be described as simpler and closer related to traditional notation. Since the effect has been defined as partially being an overtone *vibrato*, it may be depicted by means of the symbol normally used for the notation of *vibrati*. This method of depiction may be easily comprehended since the symbol and direction is well known. As displayed, Ferneyhough additionally employs a *tremolo* symbol. However, despite the depiction of the *smorzato* by means of a *vibrato* and *tremolo* symbol being exact and correct, instantaneous comprehension is compromised. A variant of notation would be to employ solely the *tremolo* symbol and the direction

¹ Brian Ferneyhough: *Mnemosyne*. Bass flute and pre-recorded tape. London et al. 1996.

smorzato. But since the effect is – as mentioned in the foreword – normally referred to as a *vibrato* variant, wavy lines are preferred here. Further, with regard to Ferneyhough’s depiction of an aperiodic *smorzato* by means of spatial notation, it may be stated that the method seems to distort the clear appearance of the score. A simpler, but admittedly less exact, method would request an aperiodic *smorzato* solely by the direction *smorzato aperiodico* or *smorzato irregolare*. When doing so, it is at the player’s discretion to determine the irregular character of the *smorzato*. This method is preferred here to that of Ferneyhough in order to enable the depiction of this articulation in a simple manner. Optionally, the rhythm could be, however, notated by means of splitting longer note values in a number of shorter ones, e. g. a minim into two quavers, a semiquaver, a quaver and a semiquaver (also cf. figure 112).

The suggested method of notation for the *smorzato* hence makes use of the *vibrato* symbol and the direction *smorzato*. As can be seen in figure 110, the player is supposed to perform a *smorzato* on the *c#/C#3* for the duration of a minim, followed by a *smorzato irregolare* on the *e/E3*, which is executed for the duration of another minim. In the case of the saxophone, the addition *di mascellare* (jaw) or *di diaframma* (diaphragm) could also be utilised (see above).

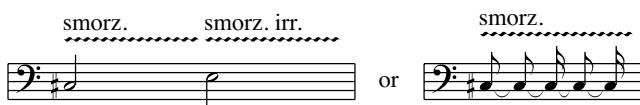

Fig. 110 The *smorzato*.

Further, the so-called extended *tremoli* and trills need to be discussed here because there is an unconventional variant of these techniques. This articulation may be referred to as *bisbigliando*, but is also known as unison *tremolo*, enharmonic trill or timbre trill. If requested, the player is supposed to quickly switch between two or more fingerings of

the same pitch. This technique may be executed on all wind instruments with keys or valves, and on the trombone only a slow *bisbigliando* is possible¹. Moreover, the *bisbigliando* may not be executed on every pitch. However, outlined in the handbooks mentioned above if two or more fingerings of the same pitch exist. When performing this articulation, actually neither a *tremolo* nor a real trill is performed because simply the timbre is changing. This effect hence strongly resembles the *smorzato* articulation.

There are various methods of notation for this technique. One is to complement the common trill notation by the direction timbre trill [Klangfarbentriller] or *bisbigliando*. An example of such a method of notation – employed by Pagh-Paan in *Dreisam-Nore* – is presented by Levine and Mitropoulos-Bott²:



Fig. 111 Levine and Mitropoulos-Bott, Flute, p. 42.

A variation of this method is suggested by Sevsay. He also employs the trill symbol, but determines that this articulation is performed without changing the pitch by utilising an additional note head in brackets. Further, he suggests two other methods of notation. Both make use of a determination of the fingerings the player is supposed to utilise for the timbre trill. As apparent from figure 112, he is required to switch between two fingerings whilst each one lasts for the duration of a quaver. The actual switch is in the example requested either by letters, index numbers or note heads that represent one of the two fingerings.

¹ Sevsay, Handbuch, p. 147.

² Please note that in Younghi Pagh-Paan: *Dreisam-Nore*. For flute alone. Munich et al. 1980, p. 1 the direction *Klangfarbentriller* is replaced by a chart of the fingerings the flautist is supposed to trill with. However, this example is not displayed here because a similar method is presented in figure 112.

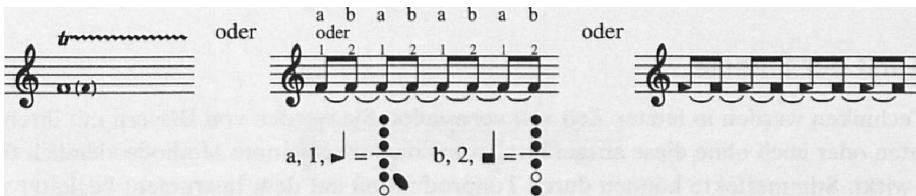

Fig. 112 Sevsay, Handbuch, p. 147.

Finally, Gallois suggests depicting the articulation by means of waved lines and the direction *bisbigliando*:

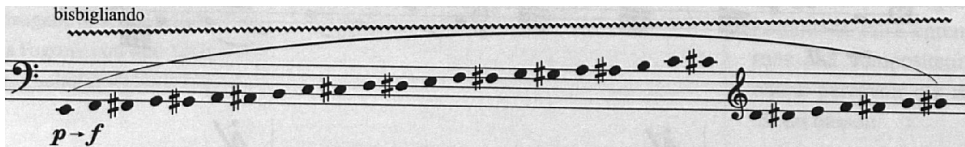

Fig. 113 Gallois, Bassoon, p. 65.

In order to discuss the previous approaches and suggest a method of notation that agrees with the postulated requirements, one needs to determine what kind of sound is produced when the *bisbigliando* technique is applied: the articulation is very similar to the previously described *smorzato* unless only the frequency is modulated, not the amplitude (as in the case of a *tremolo*). The actual performance of the articulation, however, resembles playing trill keys. Further, the timbre is not changed in a gliding way (as in the case of an overtone *vibrato*), but abruptly (as in the case of an enharmonic trill). Thus the *bisbigliando* may be rather described as an enharmonic trill than an overtone *vibrato* and is not related to the *tremolo*. Nevertheless, an overtone *vibrato* and the *bisbigliando* articulation resemble each other strongly when the latter is performed in a fast manner because in both cases only the timbre changes. Therefore, the effect is defined here as an enharmonic trill, but also the definition of this articulation as an overtone *vibrato* is regarded as valid.

As displayed, Pagh-Paan depicts an enharmonic trill. Her method may be described as simple, exact and closely related to traditional notation. However, it would have to be extended when wanting to determine fingerings. As apparent from the first example of figure 112, the enharmonic trill may be notated with a greater degree of instantaneous comprehension, which is, in this case, achieved by depicting the timbral switch by means of an additional note head. A related variant of notation would be to request the *bisbigliando* by means of an additional natural sign, which is preferred here because additional note heads are – as apparent from section ‘3. 9 Percussive effects’ – also used for the notation of key clicks and a combination of this effect with an enharmonic trill would cause an unclear appearance of the score. Further, it may be stated that Sevsay determines the fingerings and rhythm of the trill in the other two examples in a simple manner. However, the second example may be preferred to the third one. This is because – if, for instance, more than two fingerings of the same pitch were requested – the utilisation of several note heads could cause confusion. Moreover, both methods seem to depict a continuous tone even though a *legato* quaver rhythm is actually requested because the fingering repetitively switches after the duration of a quaver. Finally, an additional trill symbol should be, in any case, used in order to notate the articulation in a uniform manner. Furthermore, Gallois’ depiction of the *bisbigliando* as an overtone *vibrato* complies with the criteria apart from the fact that he does not make use of exact durations.

Thus the suggested method of notation for the *bisbigliando* either makes use of a trill symbol and the natural sign or a *vibrato* symbol and the direction *bisbigliando*. The *bisbigliando* effect is in figure 114 employed on a B \flat clarinet¹. In the first example the

¹ Cf. Krassnitzer, Klarinette, p. 161: German designations of the keys (B=B \flat) are used, and the second fingering is depicted wrongly in the book (cf. p. 28).

player is supposed to perform an enharmonic trill on the (written) $b/B\flat3$. The fingerings are in this case determined by the clarinetist. By contrast, in the second example three fingerings are determined between which he is supposed to constantly switch. Additionally, the order of the timbres could be determined by giving a direction, such as 1., 2., 1., 3., 2., 3. (*da capo*). The other two examples depict the same events. However, in this case, the *bisbigliando* is notated as an overtone *vibrato*. The rhythm is undetermined here, but could be depicted by using a number of smaller note values connected by a *legato* slur or directions, such as *irregolare* or *aperiodico*. The two alternatives are regarded here as likewise valid. However, it needs to be admitted that – even though the technique is sometimes referred to as an enharmonic or timbre trill – it may be confusing to depict it in this way since a trill is normally associated with changes in pitch.

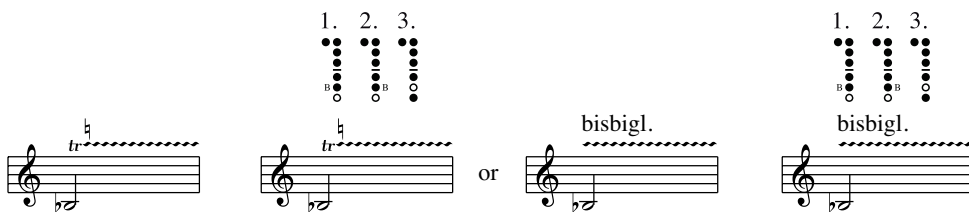

Fig. 114 The *bisbigliando* effect.

Because each instrument is different, the fingering chart needs to be altered for other woodwinds or brass instruments whilst on the trombone the slide positions – which the player is supposed to use in order to produce the same pitch – could be determined by giving a direction, e. g. 3 & 5.

Furthermore, it needs to be noted that the **conventional tremolo** on woodwinds “is the alternation between two tones, whereby the ambitus is larger than a major second”¹. Hence actually an augmented trill between two tones rather than a *tremolo* is performed.

¹ Levine and Mitropoulos-Bott, Flute, p. 42.

This is because the term *tremolo* solely describes the modulation of the amplitude. A more correct method would notate this technique similarly to a trill while describing the exact ambitus either by means of a direction (e. g. $g - eb^2/G3 - Eb5$) or using two notes with an interval larger than a major second (cf. figure 268 in the chapter on plucked instruments). However, the depiction of this articulation by means of the *tremolo* symbol and two notes has been established and will presumably be maintained in the case of wind instruments.

Further, there is another variant of this technique that is designated by Sevsay as the **broken unison tremolo**. It can be produced on woodwinds and brass instruments with valves. When requested, the player is supposed to repeatedly depress and release the same key(s) or valve(s). On brass instruments the articulation is supposed to be performed by means of two fingers that alternately depress a particular valve¹. Hence actually an extended trill between the pitch produced by a particular fingering and the pitch that evolves when the fingered key/s or valve/s is/are released is executed. Therefore, this technique may be depicted similarly to the conventional *tremolo* (or trill when the ambitus is a major second or smaller).

3.2 Extended tongue techniques

There are various effects that may be produced by means of the tongue. The most important one is designated as **flutter-tonguing**. Moreover, *pizzicato* effects may be produced and two techniques normally referred to as **slap tongue** and **tongue ram** be employed.

¹ Sevsay, Handbuch, pp. 147f.

3.2.1 The flutter tongue and its notation

Flutter-tonguing is a very popular playing technique, which has been utilised by many composers and may be produced on all wind instruments, but works best on flutes, clarinets, saxophones and brass instruments, including the horn, trumpet, trombone and tuba¹. It is discussed here because there are two types of flutter tongue. This technique may either be applied by rolling the tip of tongue on the alveolar ridge² – which is in the International Phonetic Alphabet (IPA) (see ‘Appendix A’ for a chart) designated with the sign [r] – or rolling the back of the tongue at the uvular³ – which is in the IPA designated with the sign [R]⁴.

Normally, flutter-tonguing is notated by giving the direction *Flatt.* or *Flz.* – derived from the German *Flatterzunge* – or the direction *frull.* – derived from the Italian *frullato* – and an additional *tremolo* symbol added to the note tail. This method of notation can be, for instance, found in Kelemen’s *Changeant*⁵ and is presented in figure 115. There it is not determined which type of flutter tongue the players are supposed to apply.

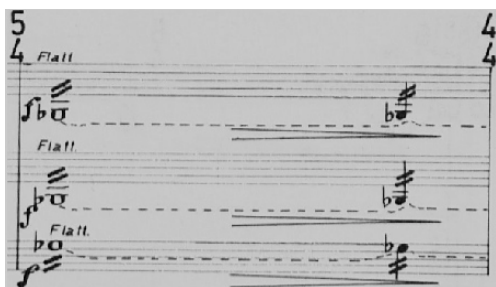

Fig. 115 Kelemen, *Changeant*, p. 44.

¹ Cf. Sevsay, *Handbuch*, p. 138.

² Cf. Gallois, *Bassoon*, p. 23.

³ In Levine and Mitropoulos-Bott, *Flute*, p. 12 the two types of flutter-tonguing are described. However, they explain wrongly that the uvular variant is produced at the glottis. As apparent from the International Phonetic Alphabet (revised to 2005), such an articulation is impossible.

⁴ Cf. Bernd Pompino-Marschall: *Einführung in die Phonetik [Introduction to phonetics]*. 2nd revised and extended edition. Berlin and New York 2003, p. 185 and the International Phonetic Alphabet (revised to 2005).

⁵ Milko Kelemen: *Changeant*. For violincello and orchestra. Frankfurt/M. et al. 1969.

However, some composers differentiate between the two flutter tongue types: in *Segmenti*¹ Serocki requests a normal variant (presumably the [R]-flutter tongue) simply by means of *tremolo* bars and (presumably) the [r]-flutter tongue² by an additional ‘(r)’ placed above these:

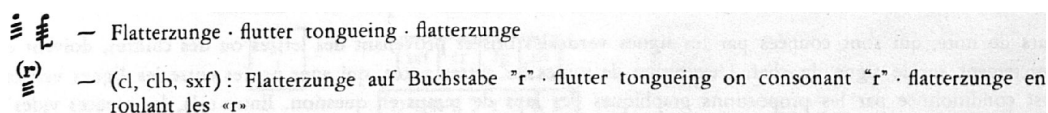

Fig. 116 Serocki, *Segmenti*, p. 4.

Further, Berio, in *Gesti*³, requests a so-called breathy and a throat flutter tongue. The breathy [r]-variant is depicted by a *tremolo* symbol and a circle added to the note tail whilst the [R]-flutter tongue is requested by writing a ‘T’ over the note:

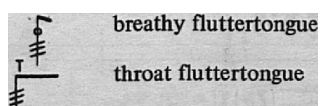

Fig. 117 Berio, *Gesti*, p. 3.

The common method of notation for flutter-tonguing (cf. figure 115) may be described as accurate. This is mainly because it can be regarded as nearly conventional and simple. When flutter-tonguing, the player produces a kind of *tremolo*⁴ and hence modulates the amplitude. However, flutter-tonguing may not be simply requested by means of the *tremolo* symbol since there is – as shown in the previous section – another articulation conventionally depicted by means of it. Unless the conventional *tremolo* always

¹ Kazimierz Serocki: *Segmenti*. For chamber orchestra. Celle 1962.

² As apparent from figure 116, he does not clearly indicate whether the ‘r’ is rolled at the alveolar ridge or the uvular. However, since Serocki was born in Poland and the [r] – but not the [R] – is a common phoneme in the Polish language, this assumption is made here (with regard to that he mentions the letter ‘r’).

³ Luciano Berio: *Gesti*. For alto recorder. London 1970.

⁴ Weiss and Netti, *Saxophone*, p. 150.

occurs in combination with two note heads – and is hence distinct from the depiction of the flutter tongue –, the utilisation of a *tremolo* symbol and only one note head to request the flutter tongue might cause confusion. An alternative of notation could be to depict this articulation by means of solely giving the direction *frullato* since it already adequately requests the performance of the flutter tongue. Therefore, Serocki's and Berio's methods of depiction for the flutter tongue itself are suggested here not being employed.

Concerning the notation of the two flutter tongue types, it may be stated that Serocki's approach may be preferred to that of Berio. This is because Berio introduces two more or less unrelated symbols in order to distinguish the two types. His approach can hence not be easily comprehended and, therefore, does not comply with the requirement of simplicity. A more comprehensible symbol is introduced by Serocki. However, he does not clearly indicate which method requests which type of flutter tongue.

Thus in order to enable the clear and simple depiction of the augmented flutter tongue, another method of notation needs to be developed: since both types may be easily described by means of the IPA, the previously introduced phonetic symbols are utilised here for their depiction. It is hence suggested depicting the 'normal' [r]-flutter tongue by means of the direction *frullato* [r] or [r]-*Flatterzunge* and the [R]-flutter tongue by the direction *frullato* [R] or [R]-*Flatterzunge*. Alternatively, the more common [r]-variant could be requested by solely giving the direction *frullato/Flatterzunge* or the flutter tongue types not be distinguished and hence the exact performance be left to the player's discretion.

When the flutter tongue types are not distinguished, the notation of this technique is actually facilitated. This is because both flutter tongue types cannot be produced in

every register of every wind instrument. For instance, on the B \flat clarinet the [r]-flutter tongue may be only used up to the (written) $g^2/G5^1$ whilst on the oboe normally the [R]-flutter tongue is utilised since the [r]-flutter tongue may disturb the reed². Therefore, one needs to be aware of the instrument's characteristic when notating both flutter tongue variants. Additionally, the flutter tongue may be performed in an irregular manner. As can be seen in figure 118, Xenakis, in *Linaia – Agon*³, requests the performance of such an articulation by means of the direction *flatterzunge irrégulier*.



Fig. 118 Xenakis, *Linaia*, p. 13.

Since this method of notation complies with all criteria, the irregular variant can be depicted by either giving this or the direction *frullato* ([r] or [R]) *irregolare*.

3. 2. 2 The *pizzicato* effect and its notation

A *pizzicato* effect can be, on wind instruments, produced in two ways: firstly, by modifying the normal articulation of the tongue. This is achieved by placing the tongue firmly on the roof of the mouth and then, supported by a strong air stream, explosively throwing it to the bottom. Secondly, the same effect may be produced by the lips. In this case, the lips are first pressed tightly together and then explosively ripped apart by a

¹ Krassnitzer, *Klarinette*, p. 21.

² Veale, *Oboe*, p. 130.

³ Iannis Xenakis: *Linaia – Agon*. For horn, trombone and tuba. Paris 1972.

strong jet of air¹. The first technique produces a rather dry and the second technique a rather wet sound. The *pizzicato* technique may be employed on all wind instruments. However, on the bassoon (and due to the similar embouchure also on the oboe) the lip *pizzicato* is preferably used².

At most times, composers do not notate two different *pizzicato* types, but simply request the performance of a *pizzicato*. In *Linaia – Agon* Xenakis simply gives a horn blower, trombonist and tuba player the direction *pizzicato*, but does not explain whether this effect is produced by means of the tongue or lips:



Fig. 119 Xenakis, *Linaia*, p. 3.

Further, Michael, in *Invocations*³, makes use of a note head shaped like an accent in order to request inter alia the tongue *pizzicato*⁴:



Fig. 120 Michael, *Invocations*, p. 6.

¹ Levine and Mitropoulos-Bott, *Flute*, p. 25.

² Gallois, *Bassoon*, p. 47.

³ Frank Michael: *Invocations*. For flute alone. Berlin and Wiesbaden 1979.

⁴ As apparent from the foreword, Michael actually requests two different articulations by means of this symbol, the tongue *pizzicato* and a technique resembling the articulation, which is in section '3. 7 Whistle techniques' referred to as the jet whistle.

The *pizzicato* effect on wind instruments is different from the original articulation on string instruments since no strings are plucked. Nevertheless, the character of both sounds is similar concerning their auditory impression, and the characterisation of this technique as a *pizzicato* has been established. Therefore, it can be regarded as valid to request the articulation by means of the direction *pizzicato*, as executed by Xenakis. Moreover, it may be stated that this method of notation is simple and closely related to traditional notation. However, in order to enable the differentiation of the two *pizzicato* types, one would have to further augment it. Opposed to Xenakis' approach, Michael's method of notation is not closely related to traditional notation since he introduces a new symbol for a technique that may also be notated in a conventional manner. Therefore, it does not agree with the postulated requirements.

Xenakis' approach is, therefore, adopted here and suggested as the method of notation for the *pizzicato* effect on wind instruments. It could be further augmented by describing the utilised *pizzicato* technique by means of the IPA. This is because both articulations are augmented clicks. The tongue *pizzicato* can actually be described by the phoneme [!], and the lip *pizzicato* may be described by the sign [⊙]. Therefore, the two types may be requested by the directions *pizzicato* [!] and *pizzicato* [⊙] (see 'Appendix A' for the IPA chart). However, the manner of performance may also be determined by the player. In such a case, it is sufficient to use Xenakis' method of notation.

3. 2. 3 The slap tongue

The two tongue techniques slap tongue and tongue ram produce similar sounds and are often confused with each other. Both techniques may be performed on all wind instru-

ments, but on the flutes only with trumpet embouchure¹ (cf. section ‘3. 3. 1 The trumpet embouchure’). This section focuses on the slap tongue whilst the tongue ram effect is explained in the following section. For example, the saxophone slap tongue is executed by pressing the tongue against the reed and almost immediately pulling it off. The slap tongue can be performed *staccato*, but may also be the attack of a longer tone. This technique can be compared to the *Bartók pizzicato* of the strings because the character of both sounds is similar².

Krassnitzer and Weiss and Netti define three different types of slaps: **1. The *secco* slap.** Only the slap portion, the percussive part of the sound is audible since the player does not blow into the instrument. The pitch is only a shadow. This type of slap can be only performed *staccato*. **2. The standard slap.** It has a clear pitch and the typical noise component of the slap tongue. It can be performed *staccato* or as the attack of a sustained tone. **3. The open slap.** At the moment of the attack, the jaw is dropped, producing a strong, percussive sound. This articulation is only possible *staccato* since the embouchure is opened³.

3. 2. 3. 1 Previous methods of notation

Holliger, in *Three pieces*⁴, requests a *secco* slap by means of an additional symbol added to the note tail. This method of notation is presented in figure 121. Other slap tongue variants are not employed in this work.

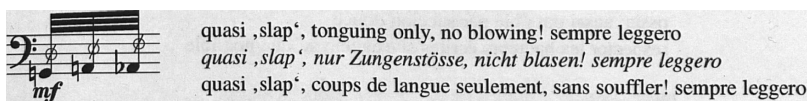

Fig. 121 Holliger, *Pieces*, p. 5.

¹ Levine and Mitropoulos-Bott, *Flute*, p. 28.

² Cf. Weiss and Netti, *Saxophone*, p. 142.

³ Cf. Krassnitzer, *Klarinette*, p. 22 and Weiss and Netti, *Saxophone*, p. 143.

⁴ Heinz Holliger: *Three pieces*. For bassoon solo. Mainz 2002.

Moreover, in *Schattenklänge*¹ Kagel requests the slap tongue by means of a circled ‘s’ placed above the note. However, he does not explain which type of slap tongue the player is supposed to execute:

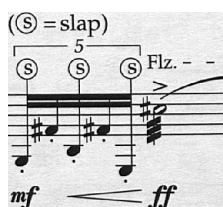

Fig. 122 Kagel, *Schattenklänge*, p. 3.

Further, Weiss and Netti present an example by Birkenkötter. In his *Tripelkonzert* for saxophone, percussion, piano (soli) and orchestra the slap tongue is requested by means of the symbol normally used for the depiction of the *Bartók pizzicato*. However, from the example it cannot be determined which type of slap tongue is requested.



Fig. 123 Weiss and Netti, *Saxophone*, p. 146.

3. 2. 3. 2 Discussion

Kagel’s method of notation (cf. figure 122) is preferred here to Holliger’s method (cf. figure 121). This is because the addition of symbols to the note tail might lead to confusion when semibreves or additional *tremolo* symbols are depicted. Unless such a long duration would, in combination with the *secco* or open slap, not be requested, it is – with regard to the necessary depiction of the standard slap – preferred here to place the symbol above the note. Although Holliger’s symbol could also be utilised in this

¹ Mauricio Kagel: *Schattenklänge*. Three pieces for bass clarinet. Frankfurt/M. et al. 1997.

way, Kagel's symbolic notation is favoured here because it contains a higher degree of instantaneous comprehension. This is because it can be easily identified as a depiction of the slap tongue technique. Further, the symbol employed by Birkenkötter (cf. figure 123) is likewise very simple and clear because the slap tongue technique produces, as mentioned, sounds that resemble the *Bartók pizzicato*. Moreover, by introducing this approach a stronger coherence would be achieved since two similar articulations would be notated in the same manner and the *pizzicato* effect is also notated by means of the method derived from string instruments (cf. section '3. 2. 2 The *pizzicato* effect and its notation'). However, none of the three methods of notation enables the depiction of the three slap tongue types. Thus the method of notation needs to be further augmented.

3. 2. 3. 3 Suggestion for the notation of the slap tongue

Hence the *Bartók pizzicato* symbol is suggested here being used for the depiction of the slap tongue articulation. When employing it, the standard slap is supposed to be executed. The *secco* and the open slap can be requested by means of the additional directions *secco* and *(bocca) aperta* (open mouth). As apparent from figure 124, the player is at first supposed to perform a *secco* semiquaver slap $c^1/C4$. It is followed by a sustained standard slap $d^1/D4$ that is the attack of a sustained tone. After a dotted crotchet rest, the player is then required to perform an open semiquaver slap $f^1/F4$. *Staccato* dots are in the example not employed because there is only one way of executing the *secco* and open slap, and the *staccato* performance is already adequately expressed by using small note values.



Fig. 124 The slap tongue articulation.

The dynamic level of this articulation is limited. For instance, the saxophone *secco* slap can be played with the dynamic level *pianissimo* to *mezzoforte*, the saxophone standard slap with the dynamic level *piano* to *forte fortissimo* and the saxophone open slap with the dynamic level *mezzoforte* to *forte fortissimo*¹.

3. 2. 4 The tongue ram

The tongue ram is a forceful, explosive effect. For instance in the case of the flutes, the tongue is propelled into the embouchure hole with a strong thrust of air and then stopped or already stopped on the roof of the mouth, respectively². However in the case of the saxophone, the tongue ‘rams’ against the reed or, with an embouchure without mouthpiece, is propelled directly into the open, upper end of the saxophone tube³. The same technique of hitting the reed with the tongue is by Gallois designated as a flap⁴ and by Veale confused with the slap tongue⁵. Additionally, the articulation is sometimes also referred to as a tongue stop⁶ and may be in a similar manner performed on all wind instruments. When performing a tongue ram on, for instance, the flutes (as mentioned, only in combination with trumpet embouchure), the produced tone sounds a major seventh lower than the fingered tone on the concert and alto flute, a minor ninth lower on the piccolo and a minor seventh lower on the bass flute⁷. The tongue ram may be only performed *staccato* since it results in the flow of air being blocked.

¹ Weiss and Netti, Saxophone, pp. 142f.

² Levine and Mitropoulos-Bott, Flute, p. 28.

³ Weiss and Netti, Saxophone, p. 148.

⁴ Cf. Gallois, Bassoon, p. 45 or Luciano Berio: Sequenza XII. For bassoon alone. Vienna 1988, no page named [foreword].

⁵ Cf. Veale, Oboe, p. 143.

⁶ Sevsay, Handbuch, p. 151.

⁷ Levine and Mitropoulos-Bott, Flute II, p. 21.

3.2.4.1 Previous methods of notation

In *Sen I*¹ Hosokawa notates the tongue ram articulation on the concert flute similarly to the way artificial harmonics on string instruments are depicted. However, in this case, the diamond-shaped note head depicts the fingering and the common note head the pitch that is produced when employing this articulation (a major seventh lower than the fingered tone):

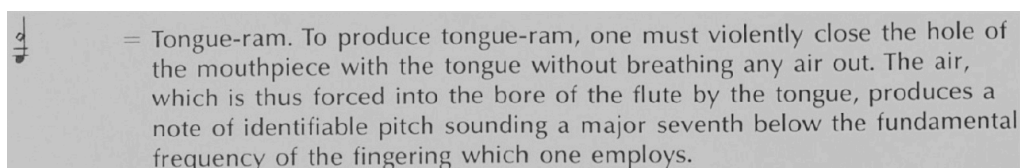

Fig. 125 Hosokawa, *Sen I*, p. 4.

Further, Sciarrino, in *Il giardino di Sara*², requests the flute's tongue ram articulation by means of a special note head shaped like a triangle:



Fig. 126 Sciarrino, *Giardino*, p. 30.

Moreover, in *Tuba Tabu*³ Braun depicts the tongue ram effect by means of a note head shaped like an accent and additionally describing the sound the player produces when performing this articulation as 'ft'⁴:

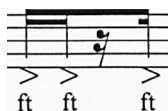

Fig. 127 Braun, *Tuba*, p. 4.

¹ Toshio Hosokawa: *Sen I*. For flute. Mainz et al. 1993.

² Salvatore Sciarrino: *Il giardino di Sara*. For voice and five performers. Rome and Milan, 2009.

³ Gerhard Braun: *Tuba - Tabu*. For tuba solo. Bad Schwalbach 2004.

⁴ Also cf. Veale, Oboe, p. 143.

3. 2. 4. 2 Discussion

Hosokawa's approach of depicting the tongue ram as a reversed artificial harmonic (cf. figure 125) can be described as exact since the fingered and resulting pitch is notated. However, opposed to the notation of artificial harmonics, it is not necessary to depict two tones, but sufficient to notate the fingering because the resulting pitch is immanent to the employed tongue ram technique. Moreover, since the tongue ram technique involves different transpositions and is – depending on the instrument – performed in slightly varying ways, the resulting pitch would have to be determined for each wind instrument. This would in turn lead to the introduction of a complex method of notation for a technique, which could simply be depicted by giving a direction. Further, Lachenmann's method (cf. figure 126) may be described as simple. When the note head is distinct to all other note heads used for the depiction of extended playing techniques of wind instruments, his method of notation may be utilised. Moreover, even though the accent note head (cf. figure 127) could not be used when semibreves were requested, it may still be described as valid. This is because the tongue ram articulation can be only performed *staccato* and hence longer note values are normally not employed. However, despite that it may be stated that Lachenmann's and Braun's methods agree with the postulated requirements, they are rejected here. This is because the slap tongue and tongue ram articulations are related to each other since similar sounds are produced. Thus in order to uniformly depict these two playing techniques, a method resembling the one for the slap tongue is preferred here to be developed.

3. 2. 4. 3 Suggestion for the notation of the tongue ram

The symbol suggested for the notation of the tongue ram technique is derived from the one utilised for the depiction of the slap tongue. As can be seen in figure 128, the

articulation is requested by means of a completely black *Bartók pizzicato* symbol, referring to the closure of the embouchure hole/reed/tube etc. (cf. figure 124).



Fig. 128 The tongue ram effect.

The tongue ram effect can be performed with a dynamic level ranging from approximately *pianissimo* to *mezzopiano*¹. Moreover, when executed without reed (oboe) or without mouthpiece (saxophone), the dynamic level can even be raised up to *mezzoforte* or *forte*² (see section ‘3. 6. 1 Detaching the headjoint/mouthpiece/reed/bocal and its notation’ for the notation of playing without mouthpiece).

3. 3 Extended embouchure techniques

In order to transform the sound of wind instruments, the embouchure may be changed. One special technique, which is normally employed on flutes, is referred to as **trumpet embouchure**. Additionally, flutes may be played with **closed embouchure**. Another technique, which can be applied on instruments with reeds, is the **teeth embouchure**. Finally, the **recorder embouchure** may be requested on all wind instruments, but the flute.

3. 3. 1 The trumpet embouchure

The technique designated as trumpet embouchure or *alla tromba* is normally executed on flutes. However, it can also be performed on the other woodwinds when playing without mouthpiece (clarinet and saxophone) or without reed (oboe, bassoon) as well as

¹ Cf. Gallois, Bassoon, p. 45, Veale, Oboe, p. 143 and Weiss and Netti, Saxophone, p. 149.

² Veale, Oboe, p. 143 and Weiss and Netti, Saxophone, p. 149.

on the flutes without the headjoint. A method of notation for removing the reed, mouthpiece or headjoint is presented in section ‘3. 6. 1 Detaching the headjoint/mouthpiece/reed/bocal and its notation’ whilst this section solely focuses on the notation of the trumpet embouchure articulation. When requested on woodwinds other than flutes, the notation for removing the reed, or the mouthpiece, needs to precede the depiction of the trumpet embouchure.

For example, in the case of the flute, a tone is created *alla tromba* through a combination of lip tension, air pressure and resonating spaces. The lips need to be pressed tightly together and forced to vibrate through a strong exhaling pressure. The production of a specific pitch is determined by the lip tension and the shape of the mouth. Hence several tones and *glissandi* may be performed without changing the fingering position¹. Further, when employing this technique tones may also be produced by inhaling air. When doing so, the pitch is lower than the fingered tone². However, when playing *alla tromba* without mouthpiece, the resulting pitch is higher than the fingered tone since the tube is shortened by the length of the mouthpiece.

3. 3. 1. 1 Previous methods of notation

The notation for this articulation has not yet been standardised. Levine and Mitropoulos-Bott recommend simply giving the direction trumpet embouchure³ (or alternatively *alla tromba*). Moreover, Holliger, in *Sonate (in)solit(air)e*⁴, makes use of an enclosed note head and an enclosed ‘T’ in order to request the trumpet embouchure. He further differentiates between trumpet embouchure while exhaling (an arrow

¹ Levine and Mitropoulos-Bott, *Flute*, p. 18.

² Cf. Veale, *Oboe*, p. 137.

³ Levine and Mitropoulos-Bott, *Flute*, p. 18.

⁴ Heinz Holliger: *Sonate (in)solit(air)e*. For flute solo. Mainz et al. 1998.

pointing down-wards added to the note tail), trumpet embouchure while inhaling (an arrow pointing upwards added to the note tail) and trumpet embouchure with less lip tension, which results in a pitch one octave or a minor seventh lower than the fingered tone (no enclosed note head, but instead the resulting pitch in brackets):

„Trompetenansatz“ beim Ausatmen
 „trumpet embouchure“ while exhaling
 „embouchure trompette“ en expirant

„Trompetenansatz“ beim Einatmen (Lippvibration)
 „trumpet embouchure“ while inhaling (with lip vibration)
 „embouchure trompette“ en aspirant (vibration des lèvres)

„Trompetenansatz“ klingt bei geringer Lippenspannung 1 Oktave, bei starker Lippenspannung eine kleine Sept (dann speziell bezeichnet) tiefer als der Griff
 „trompette embouchure“, with less lip tension sounds 1 octave, with more lip tension a minor seventh (then specially indicated) lower than the fingerings
 „embouchure trompette“ avec moins de tension des lèvres, sonne une octave, avec plus de tension une septième mineure (spécialement indiqués) plus bas que les doigtés

Fig. 129 Holliger, Sonate, p. 4.

3.3.1.2 Discussion

The utilisation of a woodwind in the same manner as a brass instrument may be compared to the utilisation of a violin or viola in the same manner as a mandolin. The latter is traditionally requested by the direction *al mandolino* (cf. section ‘2.1 Extended *pizzicato* techniques and their notation’). Thus the direction *alla tromba* would request the trumpet embouchure in close relation to traditional notation. This direction may at the same time be described as simple and is clearer than Holliger’s enclosure of the note (cf. figure 129).

Moreover, the depiction of the pitch the player is supposed to produce by means of changing the lip tension and/or inhaling needs to be determined. Holliger’s method of notation is able to depict whether the player is inhaling or exhaling. However, the addition of symbols to the note tail leads, as mentioned, to confusion when semibreves or additional *tremolo* symbols are depicted. Alternatively, the arrows could be placed over the note. But nevertheless, it would still not be obvious if the depicted tone is

related to the fingered/resulting pitch or if the fingered pitch equals the resulting pitch. It is hence clearer to notate both, the fingered and the resulting pitch, as executed by Holliger in terms of the trumpet embouchure with less lip tension (which results in a lower tone). However, firstly, the production of tones with trumpet embouchure is very complex since it is dependent on the skills of the player as well as the instrument that is employed (whilst, for instance, the instruments without mouthpiece are transposed up), and, secondly, there has not been an adequate amount of research conducted concerning this articulation. Thus it cannot be exactly determined which tones can be produced on a single fingering position, and the resulting sounds need to be determined approximately, which can be only executed by introducing an extended method of notation.

3.3.1.3 Suggestion for the notation of the trumpet embouchure

Hence trumpet embouchure is requested here by giving the direction *alla tromba*. Further, the depiction of the pitch the player is supposed to produce is not depicted by means of the traditional notation system, but by means of relative values and an additional system. This is because when the resulting pitch cannot be clearly determined, it is clearer to notate it by means of a value that represents the degree of transposition than by notating wrong or approximate pitches.

The traditional system depicts here the fingered tone and the additional system the transposition in time. The x-axis of the transposition system represents, as usual, the duration and the y-axis the degree of the transposition. There are six levels for upward and six levels for downward transpositions. The middle axis (0) represents the manner of performance that produces the most natural tone (and hence the fingered tone on the flute and, in the case of the instruments without mouthpiece, a pitch that is higher than the fingered tone). Moreover, the dots (◊◆) depict the degree of transposition in time.

This system enables the depiction of any kind of transposition executed by changing the lip tension and/or inhaling as well as *glissandi*. The act of in- or exhaling is, in combination with this system, not notated specifically since the player will automatically inhale if it is necessary to produce a certain pitch (however, also cf. section ‘3. 5. 3 The air and tone technique’ for a distinct notation of inhaled blowing). Rests are used in this system since no additional sound is produced (which would be suggested by notes), but the fingered sound transformed.

As apparent from figure 130, initially four crotchets $f^1/F4$ are supposed to be played *alla tromba*. However, each crotchet is transposed in a different manner: the first one is transposed down by $2/6$ levels, the second one transposed up by $4/6$ levels, the third one transposed up by $2/6$ levels and the last one transposed as far down as possible. Black and white dots are utilised here in order to clearly outline which note is related to which degree of transposition. Subsequently, the instrumentalist plays a semibreve $f^1/F4$. This sound is transformed in a gliding way and hence a *glissando* executed. It starts on the most natural tone, which is then gradually transposed down to level $3/6$ for the duration of a minim and subsequently transposed up to level $2/6$ for the duration of a crotchet. This pitch then remains constant for another crotchet.

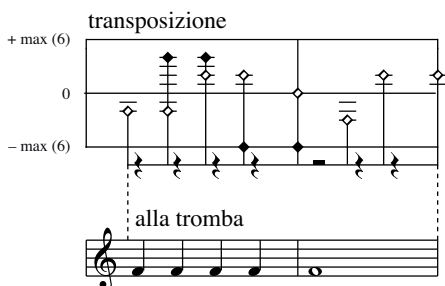

Fig. 130 The trumpet embouchure and the transposition system.

Because the pitch is modified by actually changing the lip tension and shape of the mouth the pitch bending technique is applied (cf. section ‘3. 4 Pitch bending – the

extended *glissando*'). A transposition system needs to be only applied when the resulting pitch $\neq 0$. When solely the most natural tone is supposed to be produced, it is sufficient to give the direction *alla tromba*. In the case of playing without mouthpiece, the system can be regarded as a transposing notation system. Alternatively, the transposition system may be changed to more or less than $12 + 1$ levels (please also cf. figure 136 for an alternative method of notation). Further, the dynamic level of this articulation is limited. For instance in the case of the saxophone, it can be only executed with the dynamic level *pianissimo* to approximately *forte*¹.

3.3.2 The closed embouchure and its notation

The closed embouchure is a variation of the trumpet embouchure and may be executed solely on the flutes. When requesting this rare technique, the player is supposed to cover the whole mouthpiece with his lips. Holliger depicts the closed embouchure similarly to the trumpet embouchure by means of an enclosed note head:



Fig. 131 Holliger, Sonate, p. 4.

This playing technique may be compared with the clarinet (or saxophone) embouchure since in both cases the embouchure hole is sealed with the lips. Admittedly, the relation between playing *alla tromba* and the original trumpet embouchure is stronger than that of between playing *al clarinetto* and the original clarinet embouchure, but it is still sufficient in order to describe the closed embouchure. Since such a direction is, as shown before by taking the example of the trumpet embouchure and playing *al*

¹ Weiss and Netti, Saxophone, p. 147.

mandolino, strongly related to traditional notation and clearer than Holliger's method of employing an enclosed note head as well as because it enables the uniform depiction of the different embouchure techniques, this method of notation is suggested here being utilised in order to depict the closed embouchure. Hence the technique may be simply requested by giving the direction *al clarinetto* (or alternatively *al sassofono*). In the case of the flute, the player may be additionally advised to insert the tongue into the hole of the mouthpiece when playing *al clarinetto*¹. This very rare articulation strongly resembles the more common teeth embouchure, which is in detail discussed in the following section. Therefore, a discussion of this technique is here dismissed, but it is recommended notating it in the same way as the teeth embouchure and hence by means of direction, such as *con lingua*, complementing the *al clarinetto* direction.

3.3.3 Teeth embouchure

Teeth tones may be produced by slightly touching the reed of certain woodwinds with the lower incisors². The result is that high tones of harmonic character are created³. The timbral quality of these sharp and shrill notes deviates considerably from common tones⁴. Pitches and the exact intonation of the teeth tones, however, cannot be exactly predicted since it is determined by the performer and materials. Moreover, by moving the teeth forward and backward on the mouthpiece *glissandi* occur⁵.

¹ Cf. Salvatore Sciarrino: *All'aure in una lontananza*. For G flute (or C flute or bass flute). In: Salvatore Sciarrino: *L'opera per flauto*. Milan 1990, p. 3.

² Cf. Krassnitzer, *Klarinette*, p. 26.

³ Weiss and Netti, *Saxophone*, p. 164.

⁴ Veale, *Oboe*, p. 63.

⁵ Weiss and Netti, *Saxophone*, pp. 164f.

Finally, Holliger, in *Pneuma*¹, adds a ‘Z’ to the note tail, determines which tone is fingered and differentiates between two types of teeth tones, the highest possible tone produced with a low dynamic level and a loud sounding noise:

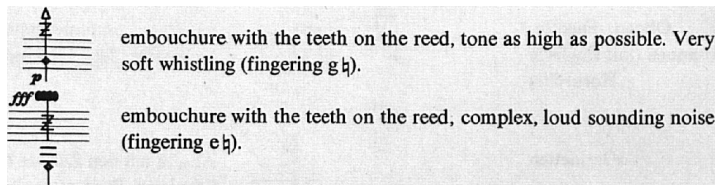

Fig. 135 Holliger, *Pneuma*, p. 6.

3.3.3.2 Discussion

Dittrich’s method of notation (cf. figure 132) is simple, but may also be described as containing redundant elements. This is because the teeth embouchure is requested by means of a direction and a crossed out note head, although utilising one of the two methods would be sufficient. Further, since techniques that resemble changing the embouchure on woodwinds are normally requested by means of directions, e. g. the determination of the manner the bow is used by directions such as *arco sul ponticello* or *col legno tratto sul tasto*, and the other embouchure techniques have also been notated in this way, the method of depicting the teeth tone by means of a special note head – as employed by Serocki (cf. figure 133) and Lachenmann (cf. figure 134) – as well as the method of requesting the teeth tone by means of a ‘Z’ added to the note tail – as employed by Holliger (cf. figure 135) – is rejected here in favour of giving the direction with teeth or *con denti* – as employed by Dittrich.

Concerning the notation of the produced pitch, it may be stated that Dittrich requests only one type of teeth tone and disregards the teeth tone variations. Moreover, Serocki’s approach is very approximate. This is because the fingered tone is not depicted and the

¹ Heinz Holliger: *Pneuma*. For wind, percussion, organ and radios. Mainz 1972.

resulting sound only determined in a very inexact manner. Lachenmann's method is even less exact since neither the fingered tone nor the resulting pitch is depicted, whilst Holliger's approach is the most exact one. However, in the case of requesting the player to produce the highest possible tone, it is not necessary to employ two note heads. As shown in section '2. 4. 1 The highest possible tone and its notation', the note head used to depict the string may at the same time request the production of the highest possible tone when it is shaped like a triangle pointing upwards. Since the string upon which the highest possible tone is produced is an equivalent to the fingering upon which the highest possible tone is produced, it would be sufficient to only employ a single note head shaped like a triangle pointing upwards in order to depict the fingered tone and the production of the highest possible pitch at the same time. Further, a loud sounding noise cannot be requested when the player is supposed to play *con denti*. This is because only high tones of harmonic character may be, as mentioned, created. Therefore, a method of notation that complies with the depiction of the highest possible pitch used in this work needs to be introduced in order to request a variation of pitches and *glissandi*.

3. 3. 3. 3 Suggestion for the notation of the teeth embouchure

The teeth embouchure is requested here by giving the direction *con denti*. In order to request the production of the most natural teeth tone/middle pitch, the highest possible tone as well as *glissandi* between these two pitches, one could simply employ common note heads (for the most natural teeth tone), triangular note heads pointing upwards (for the highest possible tone) and the common *glissando* notation. Additionally, triangular note heads pointing downwards could be employed in order to request the lowest possible tone. Such a method of notation is presented in figure 136. Here the player is at first supposed to produce the most natural teeth tone/middle pitch on the fingering position

f/*F*4 for the duration of a crotchet. Subsequently, a *glissando* from the lowest possible teeth tone to the highest possible teeth tone is performed for the duration of a crotchet on the same fingering position. The highest possible tone is then played for the duration of another crotchet and followed by the most natural tone/middle pitch, executed again on the same fingering position for the duration of a crotchet.

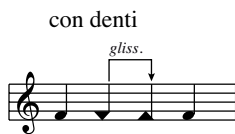

Fig. 136 The teeth embouchure.

The *glissando* is in this thesis – in order to achieve a greater clearness and enable the depiction of *glissando* motions that do not involve changes in pitch – requested by means of an arrow and not in the traditional manner. Alternatively, the common method of depiction may be restored. This might, however, cause confusion here because the notes are not transposed. Further, when more than three different pitches are supposed to be requested, a transposition system similar to the one employed in figure 130 can be utilised (and likewise the transposition system be replaced by the method of depiction introduced here when only the described three pitches are supposed to be produced by means of trumpet embouchure). As teeth tones require a change of embouchure, *legato* articulations between teeth and common tones, as well as rapid passages between these two, are not possible. Similarly problematic are large intervals and fast tempos¹. The dynamic level of this articulation ranges, for instance in the case of the saxophone, from approximately *pianissimo* to *forte fortissimo*. However, it cannot always be controlled precisely. Further, teeth tones may be combined with flutter-tonguing² (cf. section ‘3. 2. 1 The flutter tongue and its notation’).

¹ Veale, Oboe, p. 63.

² Cf. Weiss and Netti, Saxophone, p. 165 and Serocki, Swinging, no page named [foreword].

3.3.4 The recorder embouchure and its notation

The recorder embouchure is a technique, which is barely utilised. It may be requested on all wind instruments except for the flutes. Lachenmann describes this embouchure as an articulation “where the player must blow onto the mouthpiece from the shortest distance possible, similarly to playing a recorder”¹. In *Accanto* he notates the articulation by means of diamond-shaped note heads and additionally indicating to blow the mouthpiece from a distance [aus der Entfernung aufs Mundstück geblasen]:



Fig. 137 Lachenmann, Allegro, p. 11.

However, similarly to the trumpet embouchure, this technique may be requested in closer relation to traditional notation by simply giving the direction *al flauto dolce* (in the manner of a recorder). By introducing this method of notation, a uniform depiction of the trumpet, teeth and recorder embouchure is achieved. The dynamic level of this articulation is limited. As apparent from figure 137, Lachenmann, for example, requests a maximum dynamic level that is louder than *piano*, but not as loud as *forte* since “[f]orte markings in quotation marks (...) do not indicate the objective resulting volume, but (‘subjective’) intensity of the effort during the execution”².

¹ Helmut Lachenmann: *Allegro sostenuto*. For clarinet, bass clarinet in B \flat , violincello and piano. Wiesbaden et al. 2003, no page named [foreword].

² *Ibid.*, no page named [foreword].

3. 4 Pitch bending – the extended *glissando*

The term pitch bending or bend tone describes a special *glissando* technique¹. It is executed via changes in lip tension (all brass instruments) or embouchure (all woodwinds) and/or opening and closing tone holes² (only woodwinds and, for instance, in a limited manner on the piccolo, alto and bass flute)³. The extent of the *glissando* is dependent on the instrument. For instance, the B \flat clarinet pitch bending may be performed by means of opening and closing the keys over the range (of the written) *g/G3* to *g¹/G4* and from *d²/D5* upwards. These *glissandi* can additionally be reinforced above about *d²/D5* by means of the embouchure. Further, the pitch can be on this instrument only raised slightly, but lowered by several semitones⁴. Moreover in the case of the flute, the embouchure *glissando* may also be executed by turning the instrument inward (to produce a descending *glissando*) and outward (to produce an ascending *glissando*)⁵. Generally, the possible extent of these *glissandi* also depends on the tone that is fingered. Hence when requesting this technique, one needs to study the capacities of the instrument and could discuss the technique with the performers.

3. 4. 1 Previous methods of notation

Most composers notate the pitch bending articulation in an approximate way. In *Changeant* Kelemen, for instance, depicts this type of *glissando* on a trumpet by means of a line that describes how the player is supposed to bend the tone:

¹ Sevsay, Handbuch, p. 141.

² Cf. Jer-Ming Chen et al.: Pitch bending and *glissandi* on the clarinet. Roles of the vocal tract and partial tone hole closure. In: Journal of the Acoustic Society of America, vol. 126(3). No city named 2009, pp. 1511-1520, here: p. 1511.

³ Levine and Mitropoulos-Bott, Flute II, p. 37.

⁴ Chen, Pitch, p. 1511.

⁵ Levine and Mitropoulos-Bott, Flute, p. 46.

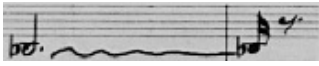

Fig. 138 Kelemen, *Changeant*, p. 29.

Moreover, Ferneyhough utilises a similar method in *Incipits*. Here the *glissando* on a piccolo is designated as lip *glissando* and a grace note employed to mark the endpoint of the articulation:

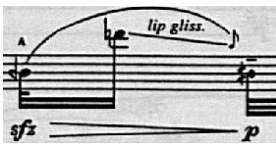
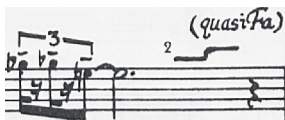

Fig. 139 Ferneyhough, *Incipits*, p. 19.

Foss, in *Echoi*¹, also makes use of a similar technique. However, in this case, the lines depict a *glissando* of exactly a quarter tone:





- 1  indicates bending pitch 1/4-tone down.
 2  indicates bending pitch 1/4-tone up.

Fig. 140 Foss, *Echoi*, p. 28.

Further, Kőszeghy requests in *Mortualium (coins for Charon)*² a *glissando*, which is performed by solely turning the flute [nur durch Drehen der Flöte]:



Fig. 141 Kőszeghy, *Mortualium*, p. 5.

¹ Lukas Foss: *Echoi*. For four soloists. Clarinet, cello, percussion, and piano. New York and Mainz 1964.

² Péter Kőszeghy: *Mortualium (coins for Charon)*. For ensemble. No city named [Berlin] 2008.

For this particular technique Dick suggests five different embouchure angles¹: normal angle [Normaler Winkel], turned slightly outwards [leicht nach außen gedreht], turned slightly inwards [leicht nach innen gedreht], as far as possible turned outwards [so weit als möglich nach außen gedreht] and as far as possible turned inwards [so weit als möglich nach innen gedreht]:

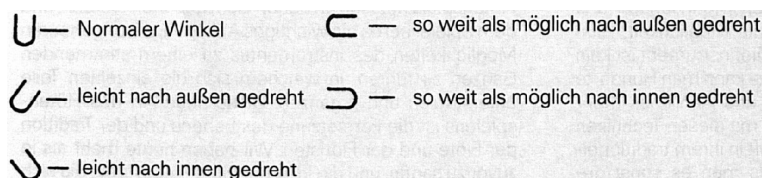

Fig. 142 Dick, Klang, p. 8.

3.4.2 Discussion

As mentioned, the pitch bending articulation may be performed in many different ways and varies from fingering to fingering. One method of notation would be to determine the extent of the tone bend for every instrument/pitch and subsequently notate the bending in the same manner as a *glissando* with microtones (whilst giving the additional direction pitch bending). However, it is at the same time very hard to apply this exact method of notation because one would have to constantly refer to lists that describe the pitch bending range. Moreover, there has not been an adequate amount of research conducted concerning this technique and hence such lists simply do not yet exist for each instrument and pitch bending technique. Therefore, when wanting to exploit the full potential of the tone bend and depict it in a uniform way for all wind instruments, it is necessary to request this articulation in an approximate way.

An approach towards the approximate notation of pitch bending has already been introduced in figure 130. It is referred to as the transposition system. When comparing

¹ Cf. Robert Dick: Neuer Klang durch neue Technik [Tone development through extended techniques]. Frankfurt/M. 1992, p. 8.

this notation system with the methods employed by Kelemen (cf. figure 138) and Ferneyhough (cf. figure 139), it may be stated that the latter two are less exact since both do not determine degrees of pitch bending, and Kelemen does not depict the bendings' exact duration. Further, Foss' method (cf. figure 140) is similar to the one employed by Ferneyhough whilst the lines enable the depiction of two degrees of pitch bending (a quarter tone up and down). However, more than these two degrees could not be depicted by means of this method.

Concerning the two methods of depiction introduced for the special pitch bending technique of flutes, it may be said that Kőszeghy's approach (cf. figure 141) could be used for the notation of this special technique if all bending ranges were known whilst Dick's suggestion (cf. figure 142) can be regarded as a valid approach towards this particular bending technique and would enable the depiction of bending degrees if the resulting pitch is not known. However, both methods could not be employed for all bending techniques and the introduction of a special method of notation for each bending technique would result in a more complex notation system than the introduction of a single method for all of them. Therefore, it is preferred here to utilise the transposition system in order to request the pitch bending articulation and leave the exact performance to the player's discretion. Alternatively, the transposition system could be limited to only one technique by giving additional directions, e. g. only embouchure, opening and closing tone holes or turning the flute.

3. 4. 3 Suggestion for the notation of pitch bending

The method of notation suggested being employed for all kinds of pitch bending techniques is hence the transposition system. It may be employed in the same manner as in figure 130. Since the direction *alla tromba* is not given in this context, it is obvious that

the respective instrument is, in this case, played with ordinary embouchure. As described above, the traditional system depicts the fingered tone and the additional system the transposition in time.

In figure 143 the pitch bending articulation is notated by taking the example of a B \flat clarinet. As mentioned, the pitch can be on this instrument only raised slightly, but lowered by several semitones. Therefore, four levels for upward and eight levels for downward transpositions are utilised whilst the middle axis (0) represents the unbent tone. Moreover, the white dots (\diamond) depict the degree of transposition in time. In the example a clarinettist continuously bends the semibreve $c^2/C5$. This tone is transposed up to the degree 3/4 for the duration of a crotchet, subsequently transposed down to the degree 4/8 for the duration of a minim and then again transposed up to the degree 1/4 for the duration of a crotchet.

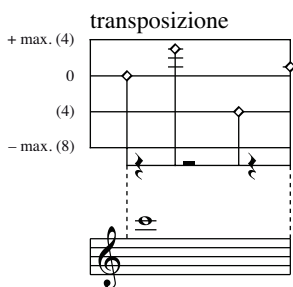

Fig. 143 Pitch bending on the B \flat clarinet.

3.5 Extended blowing techniques

Brasses and woodwinds may be utilised in an extended manner by employing special blowing techniques. The articulations explained in this section are the **singing and playing technique**, the **speaking and playing technique**, the **air and tone technique** and the effect referred to as **vocalisation**.

3.5.1 The playing and singing technique and its notation

It is possible to sing within the respective vocal range while playing any of the wind instruments. The movement of the voice is independent of playing the instrument. Female voices approximately range from $a/A3$ to $d^2/D5$ (a limited mezzo-soprano voice) and male voices from $A/A2$ to $d^1/D4$ (a limited baritone voice)¹.

The most common form of depiction is to notate the two produced tones in two systems, with the system on top representing the instrument². An example for this (nearly) conventional method can be found in Michael's *Epigramme*³. The voice [Stimme] is notated here in the lower system:

The image shows a musical score for two systems. The upper system is for an instrument, with notes marked with Roman numerals IV and VI, and a flat sign. The lower system is for the voice (Stimme), with notes marked with '1' and '3+V', and a flat sign. Dynamics markings include ppp and mp.

Fig. 144 Michael, *Epigramme*, p. 6.

Less frequently, both actions are notated in one system. In such a case, the note that is supposed to be sung is normally diamond-shaped or squared⁴. However, since the method that makes use of two notation systems, can be regarded as the most common form of notation and may be described as exact as well as simple, it is suggested here depicting the articulation in this manner. Further, as in normal voice notation, it may be determined which words the player sings. Therefore, Michael's method of notation needs to be extended. An example for such an augmentation can be found in

¹ Cf. Weiss and Netti, *Saxophone*, pp. 178f.

² Levine and Mitropoulos-Bott, *Flute*, p. 20.

³ Frank Michael: *Epigramme*. For trombone alone. Berlin 1982.

⁴ Levine and Mitropoulos-Bott, *Flute*, p. 20.

Hosokawa's *Sen I*. Here the player is supposed to sing the vowel 'u' whilst playing on the flute:

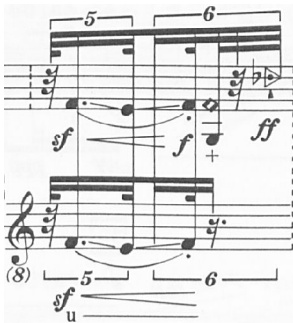

Fig. 145 Hosokawa, *Sen I*, p. 9.

However, it needs to be noted that when utilising written vowels (or consonants) in a score, they should be notated in a universal way. This is because, for instance, an English-speaking performer could interpret the letter differently from a French-speaking performer. Hence in order to level language differences and guarantee the correct pronunciation, it is suggested here always referring to the International Phonetic Alphabet when depicting text. The utilised phonemes may be either placed below or on top of the additional voice system (cf. the IPA chart in 'Appendix A').

The dynamic level of this articulation ranges, for instance in the case of the oboe and bassoon, from *pianissimo* to *mezzoforte*¹. Moreover, in order to achieve a balanced dynamic between instrument and voice, one must sing slightly louder than he plays. If this balance of presence is not achieved, the result has the effect of a rough coloration². Further, it needs to be noted that, for instance in the case of flutes, a low tone can be sung and a higher tone played as well as vice versa³, whereas in the case of the oboe the vocal pitches should be close to those played⁴. The displayed method of notation can

¹ Gallois, Bassoon, p. 27 and Veale, Oboe, p. 147.

² Weiss and Netti, Saxophone, p. 179.

³ Levine and Mitropoulos-Bott, Flute, p. 20.

⁴ Veale, Oboe, p. 147.

also be used to depict the so-called humming while playing¹. In order to request it, a nasal phoneme, e. g. [m], should be employed for the singing voice. Additionally, this technique may be combined with teeth embouchure² (cf. section ‘3. 3. 3 Teeth embouchure’).

3. 5. 2 The speaking and playing technique and its notation

A popular technique, especially on the flutes, is to make the player speak words or text sequences over the hole or directly into the flute. Here the resonance relationship of the instrument comes into play because the fingered pitch colours the resulting sound³. This articulation can be performed on woodwinds with or without the headjoint/mouthpiece/reed/bocal (cf. section ‘3. 6. 1 Detaching the headjoint/mouthpiece/reed/bocal and its notation’) and on all brass instruments.

Crumb, in *Echoes of time and the river*, makes use of speaking and playing. He notates it by giving the direction whisper through brass instruments and x-shaped note heads placed on the middle line of a five lined notation system with no clef:

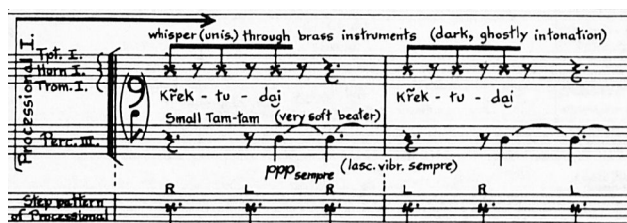

Fig. 146 Crumb, *Echoes*, p. 18.

¹ Cf. Stone, *Notation*, p. 188.

² Weiss and Netti, *Saxophone*, p. 165.

³ Levine and Mitropoulos-Bott, *Flute*, p. 37.

Moreover, Sotelo, in *Del aura al suspirar*¹, makes use of two notation systems to depict the articulation². The upper one represents the fingering whilst the lower one depicts the phonemes the player is supposed to speak by means of triangular note heads:



Fig. 147 Sotelo, *Aura*, p. 13.

When compared, Sotelo’s approach may be preferred to that of Crumb. This is because the latter neglects the influence of the fingering on the resulting sound. However, speaking produces sounds with indefinite pitch, which are, in this work, commonly notated by means of x-shaped note heads in a single lined notation system with no clef (cf., for instance, the chapter on percussion instruments). Therefore, this method of notation is also used in the case of wind instruments. Moreover, the notation of the dynamic level between the two systems seems to suggest that the pitch is not only fingered, but also ordinary blowing applied. The suggested method of notation is, therefore, a variation of Sotelo’s approach.

Analogous to the singing and playing technique, the system that determines the pitch is suggested here being placed on top and the system that determines the voice on the bottom. In order to outline that no common blowing is employed, the dynamic level of the pitches is designated as ‘∅’. Again, all phonemes should be notated with reference to the IPA (see ‘Appendix A’ for a chart). As apparent from figure 148, the player is

¹ Mauricio Sotelo: *Del aura al suspirar*. For contrabass flute (or alto flute) and sound carrier. Vienna 2001.

² Also cf. Levine and Mitropoulos-Bott, *Flute II*, pp. 28f.

supposed to speak the phonemes [tɛ], [kɔ], [tɔ] and [kɪ] into the instrument. Each has the duration of a crotchet. At the same time, he is supposed to finger an $f^1/F4$ for the duration of a minim, the two quavers $h^1/B4$ and $e^1/E4$ and a crotchet $g^1/G4$.

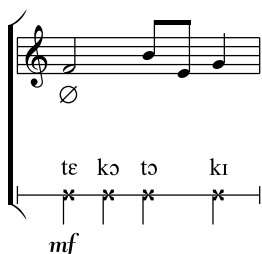

Fig. 148 Speaking and playing.

This articulation may on the flute also be performed *al clarinetto*¹ (cf. section ‘3. 3. 2 The closed embouchure and its notation’). Moreover, ‘flutter-tonguing’ can be combined with speaking and playing². However, here the direction *frullato* does not need to be employed, but simply the phonemes [r] and [R] be depicted. This is because no tones are – as in the case of real flutter-tonguing – produced (cf. section ‘3. 2. 1 The flutter tongue and its notation’). Further, in the case of all wind instruments, only the fingering influences the sound, and no overblown tones may be produced. Hence the notation of a tone that is produced by overblowing a natural tone would mean to provide false information because the text is not coloured by the higher (overblown) tone, but the lower (natural) tone. Therefore, it is, for instance in the case of the horn in F, sufficient to notate the (written) pitches $c/C3$ to $F\#/F\#2$ because they describe all possible fingerings (with the second natural $c/C3$ the normal range of the F horn begins whilst each of the six possible fingerings lowers it by a semitone). Special tongue effects, such as the smacking noise or kissing sound³, respectively, can be also depicted

¹ Cf. Holliger, *Sonate*, p. 4.

² Cf. Lachenmann, *Staub*, no page named [foreword].

³ Cf. Lachenmann, *Niente*, no page named [foreword] or Holliger, *Pieces*, p. 5.

by means of the International Phonetic Alphabet. They are in the chart referred to as clicks.

Additionally, a hybrid of singing/playing and speaking/playing may be performed by making the player **whistle into the embouchure hole**¹. This articulation is especially effective on flutes. In order to depict it, the methods of notation for singing/playing and speaking/playing need to be combined: the upper system would again represent the fingered pitch of the resonating instrument while the dynamic level of the pitches would have to be determined as ‘Ø’. Moreover, the lower system would be used to depict the whistled pitches. The notation of whistling is here, however, not discussed, but subject to a followup work on vocal techniques because it is rather a vocal than a blowing technique.

3.5.3 The air and tone technique

The air and tone articulation or air sound is created when an amount of air is mixed with the normal tone². Actually, this articulation is a variation of the technique designated as speaking and playing. However, normally only fricatives (cf. the IPA chart in ‘Appendix A’) are articulated in order to produce the air sound. Weiss and Netti, for instance, (presumably) suggest the fricatives [s], [ʃ], [χ] and [ħ]³ for the transition from bright to dark air sounds. Another difference to speaking and playing is that the sound is not just coloured, but the pitch may be clearly perceived. The air and tone technique can be employed on all wind instruments.

¹ Cf. Holliger, *Sonate*, p. 7.

² Levine and Mitropoulos-Bott, *Flute*, p. 35.

³ In Weiss and Netti, *Saxophone*, p. 157 they actually designate the phonemes as ‘s’, ‘sh’, ‘hr’ and ‘hro’. These sounds were transferred to phonetic spelling.

3.5.3.1 Previous methods of notation

There are various examples for the notation of air sounds. In *Das atmende Klarsein* Nono, for instance, differentiates between air and tone technique and the (toneless) speaking and playing technique. The air and tone technique is requested by means of a blank triangular note head added to the tail, while a transition to speaking and playing may also be performed. Additionally, he requests the player to exhale or inhale by means of additional arrows (which complement the dynamic level)¹:







	prevalence of the sound of breath, with little or no presence of pitched sound;
	mixture of sound at a determined pitch and breath, proportionally in accordance with proximity to sound production ∇ or \blacktriangle ;
	sound produced normally;
	gradual transition from one method of sound production to another;
	aperiodic tremolo, of irregular speed, with a gradual transition from sound production ∇ to sound production \blacktriangle ;
	breathing out;
	breathing in;

Fig. 149 Nono, *Klarsein*, p. XIV.

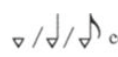
Moreover, in *Schattenklänge* Kagel requests two air sounds, very breathy and half breathy. He depicts the former one by means of a white diamond-shaped note head and the latter one by a black and white diamond-shaped note head placed over the system:

Adagio (♩ ca. 54), ma poco rubato



\diamond (= stark gehaucht / very breathy) — auf der Zeit / on the beat

\blacklozenge (= halb gehaucht) (= half breathy)

pp, *dolcissimo* *ppp*

Fig. 150 Kagel, *Schattenklänge*, p. 2.

¹ Cf. *ibid.*, p. 2.

Finally, Katzer, in *Dialog imaginär*¹, requests a transition from air [Luft] to tone [Ton] whilst the air sound is depicted by means of a diamond-shaped note head:

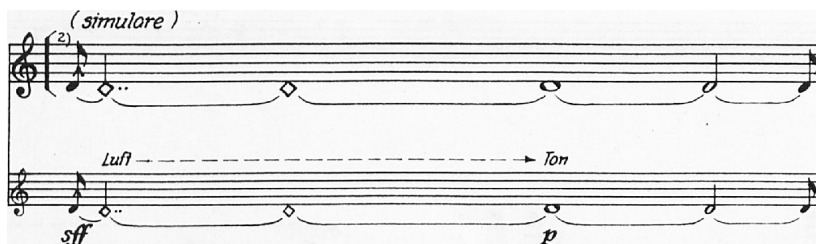

Fig. 151 Katzer, *Dialog*, p. 1.

3.5.3.2 Discussion

As mentioned, the air and tone articulation is a variant of the speaking and playing technique. Since a method of notation has been suggested for the latter, the displayed approaches need to be compared to it. As apparent, none of the previous attempts (cf. figure 149 to 151) is as exact as the method presented in figure 148 concerning the notation of the actual air sounds and the ratio between the dynamic levels of air and tone. This is mainly because in none of the examples is it specifically determined which air sound the player is supposed to produce. Further, Nono's approach (cf. figure 149) of adding a note head to the note tail might be compromised when utilising additional *tremolo* symbols or semibreves. Concerning the depiction of in- and exhaling, it may be stated that they are rather related to the phonemes than the dynamic level. Therefore, it is preferred here to place these over the articulated phoneme. Moreover, it is sufficient to solely request the action of inhaling since fricatives are normally pronounced whilst exhaling. Furthermore, Kagel only determines two ratios, very breathy and half breathy (cf. figure 150) whilst Katzer's method is solely able to depict the speaking and playing technique, the air and tone technique as well as the transition from one to the other.

¹ Georg Katzer: *Dialog imaginär*. For flute and tape. In: Werner Tast (ed.): *Zeitgenössische Musik für Flöte solo* [Contemporary music for flute alone]. Leipzig 1987, piece no. 8.

Additionally, his method suggests that the fricative itself has a definite pitch (cf. figure 151). Finally, since the approach of using two notation system is – as shown in figure 152 – able to describe the transition from air sounds to normal tones as well as many different ratios and air sounds, it is preferred here to Nono's, Kagel's and Katzer's method.

3.5.3.3 Suggestion for the notation of the air and tone technique

The method of notation suggested for the air and tone technique is derived from the one introduced for the speaking and playing technique. Hence the upper system represents the fingered pitch and the lower system the air sounds or phonemes the player articulates. As mentioned, the ratio between the air and tone is depicted by means of the dynamic level assigned to each system. When the dynamic level for the pitches drops to 'Ø', the speaking and playing technique is performed¹.

As can be seen in figure 152, the player is supposed to articulate the fricatives [s], [ʃ], [χ] and [ħ]. Each phoneme has the duration of a crotchet whilst the dynamic level is increased from *piano pianissimo* to *mezzoforte* for the duration of a minim and then decreased to quadruple *piano* for the duration of a crotchet. Further, the third fricative [χ] is requested here to be produced whilst inhaling. Opposed to Holliger's method of notation, the arrow that request it, is pointing downwards. This is because the jet whistle technique (where the player exhales) is notated by an arrow that points upwards (cf. section '3.7.2 The jet whistle'). As in figure 148, the player is supposed to finger an *f¹/F4* for the duration of a minim, the two quavers *h¹/B4* and *e¹/E4* and a *g¹/G4*. However, this time the pitch can be clearly perceived since the dynamic level is

¹ In Levine and Mitropoulos-Bott, Flute, p. 36 the articulation of fricatives without blowing is designated as aeolian sounds. In fact, however, this action is a variant of the speaking and playing technique.

constantly *mezzoforte*. Moreover, the last note has the duration of a semibreve and a crotchet. The transition from air and tone to the production of only tones is achieved by reducing the dynamic level of the phonemes and stopping the production of phonemes with the beginning of the second bar. A transition from speaking and playing to the air and tone technique could be depicted by making the player articulate a fricative and increasing the dynamic level of the upper system from 'Ø' to any other dynamic level. Moreover, a transition to playing and singing could be depicted by replacing the single lined notation system by a pitch-based notation system.

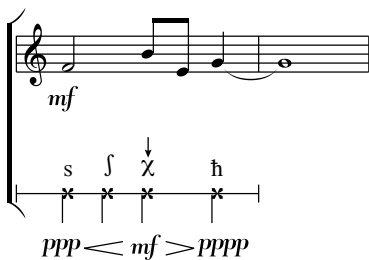

Fig. 152 Air and tone.

The maximum dynamic level of the air sound is always dependent on the fricative employed to produce it. Generally, only low dynamic levels are possible in the case of unvoiced phonemes and higher dynamic levels in the case of voiced phonemes. Moreover, the *alla tromba* embouchure (cf. section '3. 3. 1 The trumpet embouchure') can be combined with air tones. However, in this case, exact pitches are not produced¹. Further, when the air is sucked in and not exhaled, the timbre and pitch is dependent on the instrument. For instance in the case of the bassoon, sounds that strongly resemble that of a French horn may be created after removing the reed² whilst on the oboe sucking noises do not have a precisely determinable pitch³ (also cf. section '3. 3. 1 The trumpet

¹ Veale, Oboe, p. 137.

² Gallois, Bassoon, p. 50.

³ Veale, Oboe, p. 146.

embouchure’ for ‘automatic’ inhaled blowing). Further, the articulation may vary according to the phoneme that is pronounced when inhaling. The phonemes that are closely related to the normal breathing action are the bilabial [ɸ] or the glottal [h], while the latter phoneme can also be employed to depict the so-called diaphragm accents¹. Additionally, air sounds may also be performed *al clarinetto* and with a kind of *al flauto dolce* embouchure² (cf. sections ‘3. 3. 2 The closed embouchure and its notation’ and ‘3. 3. 4 The recorder embouchure and its notation’).

3. 5. 4 Vocalisation and its notation

Vocalisation refers to the technique of changing a tone’s timbre by altering the resonance of the mouth cavity. In order to do so, vowels are formed with the mouth whilst simultaneously playing held notes³. However, these vowels are not articulated, but simply determine the position of the tongue and lips. In the case of a bright vowel, such as [i] or [a], a bright sound is produced by favouring high overtones, whereas in the case of a dark vowel, such as [y], [o] or [u], the sound will be darker because low overtones are favoured⁴. The vocalisation technique may be described as a variation of the speaking and playing articulation. However, in this case, the vowels colour the produced pitch. The articulation may be performed on all wind instruments.

Gallois suggests notating vocalisation by writing vowels over the note that depicts the fingered pitch. As apparent from figure 153, he does not make use of the IPA.

¹ Cf. Helmut Lachenmann: *temA*. For flute, voice (mezzo-soprano) and violincello. Cologne 1971, no page named [foreword], Pagh-Paan, Dreisam-Nore, no page named [p. 1] or Takashi Matsuoka: *Pietà*. For flute alone. Tokyo 1989, p. 4.

² Cf. Lachenmann, Staub, no page named [foreword].

³ Veale, Oboe, p. 146.

⁴ Cf. Weiss and Netti, Saxophone, pp. 21f.

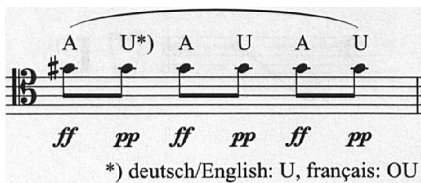

Fig. 153 Gallois, Bassoon, p. 22.

If the vowels were depicted by means of phonemes derived from the International Phonetic Alphabet, Gallois' approach could be described as adequate since it is exact and simple. However, in order to achieve a uniform method of notation for the singing and playing, speaking and playing as well as the air and tone technique, another approach is introduced here. It is a variant of the method displayed in figure 148. In this case, the pitch may be, however, clearly perceived, and the vowel is only formed with the mouth. In order to outline that the vowels are not pronounced, their dynamic level is designated as '∅'. In the example presented in figure 154, the player is during normal blowing supposed to form each of the vowels [i], [a], [y] and [u] for the duration of a crotchet.

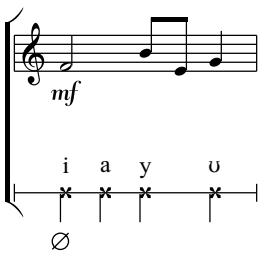

Fig. 154 Vocalisation.

3. 6 Preparing the instrument

This section focuses on two main ways of modifying wind instruments, **detaching the headjoint/mouthpiece/reed/bocal** and **constructional modifications**.

3. 6. 1 Detaching the headjoint/mouthpiece/reed/bocal and its notation

The most common way of preparing wind instruments is to detach the headjoint (flutes) mouthpiece (clarinets, saxophone and brass instruments), reed or bocal (oboes, bassoons). When the mouthpiece is removed, the resulting pitch is higher. This is also valid when removing the headjoint or reed.

Detaching the headjoint/mouthpiece/reed/bocal is normally requested by giving a direction. An example of such a method of notation – as employed by Heyn in *Buon natale, fratello Fritz* – is presented by Weiss and Netti:



Fig. 155 Weiss and Netti, Saxophone, p. 149.

Moreover, Leidel, in *Drei Aperçus*¹, requests a bassoonist to remove the reed in a similar manner². The detachment or re-attachment of the headjoint/mouth-piece/reed/bocal can be compared to the attachment and removal of a mute on string instruments. Since this articulation is also normally requested by means of a direction (*con/senza sordino*), Heyn's and Leidel's method may be described as being closely related to traditional notation. Moreover, the employment of short directions may be regarded as simple. Therefore, it is suggested here requesting the detachment and re-attachment of the headjoint/mouthpiece/reed/bocal by means of the direction without/with the headjoint/mouthpiece/reed/bocal or *senza/con testata* (flutes), *imbocatura* (clarinets and saxophones), *bocchino* (brass instruments), *ancia* or *aletta* (oboes, bassoons).

¹ Wolf-G. Leidel: *Drei Aperçus*. For bassoon. In: Dieter Hähnchen (ed.): *Zeitgenössische Musik für Fagott solo* [Contemporary music for bassoon alone]. Leipzig 1986, p. 54a.

² *Ibid.*, p. 54a.

As explained above, the articulation *alla tromba* is on clarinets, saxophones, oboes and bassoons always executed *senza imboccatura/ancia*. When detaching the mouthpiece and playing in this way, the pitch can be, as mentioned, still depicted as if the mouthpiece was not detached because the system may be, in such a case, regarded as a transposed notation system. Additionally, the removal of other parts, such as the *oboe d'amore's* crook, may be depicted analogously and hence by directions. Further, other embouchures, such as *al clarinetto* or *al flauto dolce* (cf. section '3. 3 Extended embouchure techniques'), and effects, such as the *pizzicato*, slap tongue and flutter tongue (cf. section '3. 2 Extended tongue techniques'), may be employed in combination with the described preparations. When the mouthpiece of clarinets and saxophones is detached, it may be useful to additionally determine which type of embouchure the player is supposed to apply. This is because the embouchure hole is, in such a case, very different from the original one.

Additionally, it is possible to only **play on the headjoint/mouthpiece** of wind instruments. Szalonek requests this articulation in *Concertino*. The flute player is there supposed to detach the headjoint of the flute and play on it. He determines that three different tones can be produced. These tones are notated by means of x-shaped note heads:

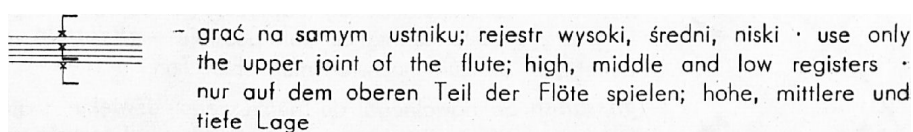

Fig. 156 Szalonek, *Concertino*, p. 3.

However, it would be clearer to request the utilisation of only the headjoint or mouthpiece analogous to the way the other embouchure techniques are notated because it is related to these. In order to do so, the simple direction on the headjoint/mouthpiece or *sulla testata/imboccatura/bocchino* is suggested here being employed. Further, since

x-shaped note heads are, in this work, utilised for the depiction of key clicks (cf. section ‘3. 9. 1 Key/valve clicks’), another method of notation for the resulting pitch needs to be introduced. One method would be to determine which tones may be produced by blowing on the headjoint/mouthpiece. However, if the resulting pitch is not known, another method has to be applied. Since this is the case here, a different approach is adopted.

The suggested method refers to the three registers that may be produced on headjoints of flutes, as determined by Szalonek, and the method of notation for the teeth embouchure displayed in figure 136. When playing *sulla testata/imbocatura/bocchino*, a single lined notation system with no clef is used. Three tones in figure 157 are depicted by this system: the most natural tone by means of common note heads, the highest possible tone by triangular note heads pointing upwards and the lowest possible tone by triangular note heads pointing downwards. A flautist is in the example supposed to produce the most natural tone on the headjoint for the duration of a crotchet and then play the highest possible tone for the duration of a minim. Subsequently, the lowest possible tone is supposed to be produced for the duration of a crotchet. In order to depict more than three tones, the single lined notation system could be further augmented by means of additional lines.

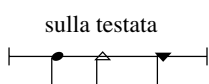

Fig. 157 Playing on the headjoint of a flute.

3. 6. 2 Constructional modifications and their notation

There have been various attempts at combining parts of different instruments with each other, e. g. taping a double reed to a brass instrument, utilising additional joints, valves

or mouthpieces, e. g. trumpets with two mouthpieces and/or six to seven valves¹. Moreover, Holliger, in *Siebengesang*², requests the player to use a casing/shell/tube instead of the oboe's reed^{3/4}. Simpler modifications can be executed by removing the lower joint, bell etc. of a woodwind instrument or the slide of a trombone⁵.

As in the case of string instruments, there are numerous ways of preparing wind instruments. Similarly, it is also, on the one hand, barely possible to list them all and subsequently develop a coherent method of depiction whilst, on the other hand, it is also not necessary to do so since most preparations are executed previously to a performance and may be simply described in the foreword to a work. When preparations are supposed to be executed during a performance, they are suggested here being always notated by means of a sketch. This is because it is the simplest way of depicting these. When the sketch is not clear enough, it may be complemented by an explanation (cf. section '2. 8 Preparing the instrument and its notation'). Nevertheless, preparations may, as mentioned, lead to the introduction of new playing techniques that should then be notated in accordance with all other techniques presented in this work.

3. 7 Whistle techniques

Whistle techniques are primarily used on flutes⁶. There are two types of whistle sounds, **whistle tones** and an articulation designated as **jet whistle**.

¹ Sevsay, Handbuch, p. 153.

² Heinz Holliger: *Siebengesang*. For oboe, orchestra, singing voices and loudspeaker. Mainz 1969.

³ *Ibid.*, pp. 53 and no page named [appendix].

⁴ Holliger uses the ambiguous German word *Hülse*, which is wrongly translated as 'bare staple'.

⁵ Sevsay, Handbuch, p. 151.

⁶ Cf. Sevsay, Handbuch, p. 143.

3.7.1 Whistle tones and their notation

Whistle tones are lightly fluctuating tones in the very high register based on the harmonic series¹. These sounds can be, for instance in the case of the concert flute, produced by using the fingerings of the lowest register (*h/B3* or *c¹/C4* to *eb²/Eb5*) as well as those for the highest register (from *d³/D6* on). This is because the middle register is produced by overblowing to the second partial. When whistle tones are requested, the player needs to turn the flute slightly outward and blow across the embouchure hole with almost no lip tension. The air stream is then weak, but remains constant².

Whistle tones are most commonly notated by depicting the fundamental by means of a diamond-shaped note head and the produced harmonic by a normal note head. For instance, in *All'aure in una lontanza* Sciarrino requests whistle tones in this manner (and additionally determines different types of embouchure by means of the diamond-shaped note, which are discussed in detail below)³:



Fig. 158 Sciarrino, *All'aure*, p. 6.

Other similar examples can be found in Levine and Mitropoulos-Bott^{4/5}. This method of notation also resembles the one conventionally employed for the depiction of certain harmonics on string instruments. Diamond-shaped note heads are in this context used to outline that a particular position on the string needs to be lightly fingered in order to

¹ Levine and Mitropoulos-Bott, *Flute*, p. 15.

² Cf. Levine and Mitropoulos-Bott, *Flute*, pp. 15f., 65-67 and 68-70.

³ Cf. Sciarrino, *Dall'aure*, p. 3.

⁴ Levine and Mitropoulos-Bott, *Flute*, pp. 16f.

⁵ Levine and Mitropoulos-Bott, *Flute II*, p. 14.

create a harmonic^{1/2}. As mentioned, in the case of the whistle tones, the player needs to produce a weak air stream with low lip tension in order to create harmonics. Hence lightly fingered harmonics on string instruments and whistle tones on flutes resemble each other. Therefore, it may be stated that the method of notation utilised by Sciarrino is related to traditional notation. Thus Sciarrino's method of notation is suggested here being employed for the notation of whistle tones. It is distinct from the depiction of common harmonics since these are requested by means of two common note heads (for the fingered tone and the harmonic) and a small circle on top of the upper tone.

The dynamic level of whistle tones is always low. Further, this technique can be also employed *al clarinetto* and with an additional 'tongue embouchure'³ (cf. section '3. 3. 2 The closed embouchure and its notation'). As mentioned, whistle tones are primarily a flute technique. However, when the reed is removed on the oboe or the reed and crook on the oboe d'amore and the cor anglais (cf. section '3. 6. 1 Detaching the headjoint/mouthpiece/reed/bocal and its notation') and the closed embouchure is applied, similar sounds may be created by inhaling. Moreover, whistle tones may also be produced by claspings the lips around the aperture of the cor anglais' crook (without reed)⁴.

3. 7. 2 The jet whistle

A jet whistle is a short, forceful and loud attack of air. It may be only created on the flutes. When requested, the embouchure hole of the flute is completely covered with the lips (and hence the *al clarinetto* embouchure employed) while exhaled air is forced into the flute with a strong air impulse. The lower the pitch that is fingered, the richer

¹ Sevsay, Handbuch, p. 70.

² Even though the produced harmonic does not, in this case, need to be depicted since it cannot be varied on string instrument.

³ Cf. Levine and Mitropoulos-Bott, Flute, p. 17 and Sciarrino, All'aure, p. 3.

⁴ Veale, Oboe, p. 138.

frequencies are produced. The jet whistle conjures up associations with the starting of a jet plane and includes a *glissando*-like rise in pitch¹.

3.7.2.1 Previous methods of notation

There are many different approaches towards the notation of the jet whistle. Most of them try to depict the energetic quality of the attack. For instance, Lachenmann, in „... zwei Gefühle ...“, *Musik mit Leonardo*, makes use of a bent line that replaces the note head whilst a common note in brackets determines the fingering:

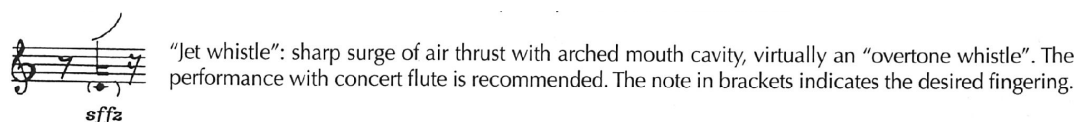

Fig. 159 Lachenmann, *Gefühle*, no page named [foreword].

As can be seen in figure 160, Holliger, in *Sonate (in)solit(air)e*, makes use of an additional arrow to depict the articulation (which is followed by a tongue ram). As explained above, the note head is circled in order to outline that the player is supposed to perform this articulation *al clarinetto*.

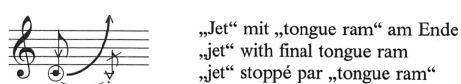

Fig. 160 Holliger, *Sonate*, p. 4.

Another method is utilised by Lachenmann in *Staub*. In this piece he makes use of an oval note head and a common note head in brackets for the depiction of the jet whistle:

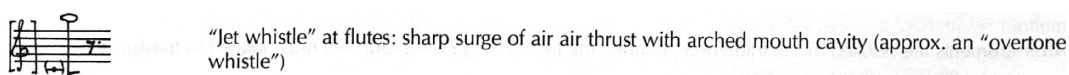

Fig. 161 Lachenmann, *Staub*, no page named [foreword].

¹ Cf. Levine and Mitropoulos-Bott, *Flute*, p. 17.

3.7.2.2 Discussion

In order to notate the jet whistle articulation in a comprehensive way, it is preferred here to utilise a method of depiction that displays the forceful nature of the air attack. Therefore, Lachenmann's first method (cf. figure 159) and Holliger's method (cf. figure 160) are favoured from the approach of depicting the action by means of an oval note head (cf. figure 161). However, as shown above, the action of inhaling and exhaling is normally depicted by means of arrows. Since the jet whistle is in the first place an air attack, Holliger's method of utilising an additional arrow does make sense. Moreover, since the overtones are emphasised and a kind of ascending *glissando* is elementary to the articulation, the arrow should point upwards. Therefore, it is preferred here to utilise an additional arrow instead of a bent line. Furthermore, since there is no necessity for employing two note heads, it is preferred to solely depict the fingered pitch. As shown in section '3.3.2 The closed embouchure and its notation', the embouchure necessary for the air attack is, in this work, depicted by means of the direction *al clarinetto*.

3.7.2.3 Suggestion for the notation of the jet whistle

The jet whistle technique is hence suggested being notated by means of employing a normal note head that depicts the fingered pitch, an additional arrow pointing upwards and giving the direction *al clarinetto*. As can be seen in figure 162, the player is supposed to finger a *c¹/C4* and perform the jet whistle articulation for the duration of a quaver.

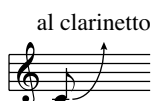

Fig. 162 The jet whistle.

Further, a subsequent tongue ram could be depicted by an additional note connected by means of a *legato* slur and the method presented in section ‘3. 2. 4 The tongue ram’.

3. 8 Muting

The application of mutes is not very effective on woodwinds, but a very popular technique on brass instruments¹. Mutes can either be employed in the common way by inserting them previously to a passage and removing them afterwards or be applied and removed repetitively in a fast manner during the sound production in order to produce **the wah-wah effect**.

3. 8. 1 The application of mutes

On woodwinds normally a piece of cloth or a handkerchief is loosely inserted in the sound hole at the end of the instrument. Another possibility is to cover the opening with a suitable item, such as a mute made of cork. However, in both cases, only certain tones are influenced by the muting. Moreover, when playing on the mouthpiece of a clarinet or saxophone (cf. figure 157), it can be muted by means of putting the hand over the opening. Further, the horn player can achieve a muting effect by hand stopping, i. e. pushing the hand tightly into the bell. This action, however, raises the pitch. The player compensates this effect by fingering a semitone lower. The commercial horn mute corrects the alteration in pitch that would be caused by hand muffling. For the tubas, there is only one mute available whilst a large collection of mutes exists for the trumpets and trombones, such as the straight mute, the cup mute, the whispa mute, the solotone mute, the bucket mute and the harmon or wah-wah mute. Harmon mutes are manufactured with and without stem. The stem can be adjusted to produce a variety of

¹ Sevsay, Handbuch, p. 142.

timbres. There are three positions, stem in, half stem and stem out. Additionally, these instruments can be muted by means of a plunger, a hat or derby, by putting the hand over or in the bell, inserting cloth/a handkerchief in the bell or playing into the stand. Moreover, it is also possible to insert other items into the bell, e. g. paper, fur or a small basket (please refer for further details to Adler¹, Rehfeldt² or Sevsay³).

3. 8. 1. 1 Previous methods of notation

The action of employing a mute is, as on string instruments, normally requested by means of giving the direction with/without mute or *con/senza sordino*. For instance, Halffter, in *Lineas y puntos*⁴, employs such a method of notation for the horn section:

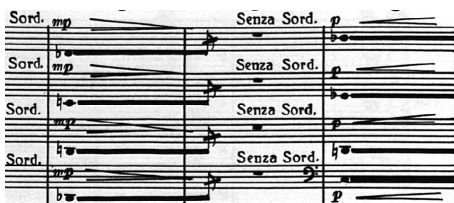

Fig. 163 Halffter, *Lineas*, p. 7.

Moreover, in order to outline which mute the player is supposed to utilise, Kelemen, in *Changeant*, gives an additional description of the type in brackets (cup mute):



Fig. 164 Kelemen, *Changeant*, p. 29.

¹ Adler, *Orchestration*, pp. 308-311.

² Rehfeldt, *Directions*, pp. 72-74.

³ Sevsay, *Handbuch*, pp. 142-144.

⁴ Cristobal Halffter: *Lineas y puntos*. For 20 instruments, 2 loudspeakers and tape. London 1967.

Further, Ligeti makes use of the same method. In *Apparitions*¹ he requests a trombonist to use cardboard as a mute by giving the direction with mute (cardboard) [mit Dämpfer (Karton)]:



Fig. 165 Ligeti, *Apparitions*, p. 2.

However, Kagel requests the application of mutes in *Atem*² by means of symbols and numbers, indicating which type of mute is utilised:

Mutes: The indications regarding mutes (□, □, □, □) apply first and foremost to brass instruments*. The performer will need as many different mutes as there are numbers. The same number always means the same mute (□ = mute A, □ = mute B, etc.).

Fig. 166 Kagel, *Atem*, p. 4 [foreword].

Finally, Holliger requests in *Siebengesang* to mute the horn only as far as to make it sound a quarter tone higher³. This effect is requested by means of the plus sign and microtonal symbols:



Fig. 167 Holliger, *Siebengesang*, p. 58.

3. 8. 1. 2 Discussion

As apparent from the examples, the application of a mute is commonly requested by means of giving a direction. Moreover, since the same method of notation is also

¹ György Ligeti: *Apparitions*. For orchestra. 2nd revised edition. Vienna 1971.

² Mauricio Kagel: *Atem*. For a wind instrumentalist. London 1976.

³ Cf. Holliger, *Siebengesang*, p. 58.

conventionally employed in the case of string instruments, it may be regarded as being closely related to traditional notation. With regard to the utilisation of different mutes, they may be either depicted by means of writing these mutes down (cf. figure 164 and 165) or by a symbol and numbers (cf. figure 166). In the case of the former method, the direction in brackets needs to be short in order to preserve instantaneous comprehension. When the application of a special mute requires additional information, it should be provided in the foreword to the work. To give an example, Ligeti employs in *Aventures* a “vase with a relatively small opening (short, narrow, neck)”¹ as a mute. This information is part of the score. However, in such a case, the description of the vase should be presented in the foreword and the actual application be rather requested by means of the direction *con sordino* (vase).

Concerning the depiction of the mute type by means of a symbol and numbers, it may be stated that it is simpler to request a particular mute by means of a description than by a number since the former method does not require previously learning the meaning of the numbers. Therefore, it is preferred here to utilise the method of notation employed by Kelemen and Ligeti in order to request the normal mutes. However, when uncommon mutes – such as the vase – are employed, the utilisation of a symbol for the item could contain a higher degree of instantaneous comprehension than requesting it by means of a direction. Further, when microtonal frequencies are supposed to be produced (cf. figure 167), this action can be clearly requested by means of microtonal symbols. However, in order to depict the application of the mute in accordance with traditional notation, the plus symbol would have to be replaced by the direction *con sordino* (hand) or (*mano*).

¹ György Ligeti: *Aventures*. For three singers and seven instrumentalists. Frankfurt/M. et al. 1964, p. 7 [appendix].

3. 8. 1. 3 Suggestion for the notation of the application of mutes

The attachment and removal of mutes is hence requested by giving the direction *con/ senza sordino* whilst the description of the mute type may be given in brackets. In the case of the tuba or if only one mute type is used, it is apparently sufficient not to specify what kind of mute the player is supposed to employ. When utilising the harmon mute with stem, the additional direction in, half and out (*dentro*, $1/2$ or *mezzo* and *fuori*) needs to be given. Moreover, the utilisation of special mutes, such as the plunger, hat, hand, cloth, a handkerchief and even the note stand, can also be requested in this manner¹. However, for such uncommon mutes a symbol could, as mentioned, alternatively be introduced.

3. 8. 2 The wah-wah effect

The wah-wah effect is on brass instruments produced by adjusting the harmon mute with the hand in order to open or close the bell. In the case of the stem being adjusted to the stem out position, the sound is thin but sharp, and, in the case of being adjusted to the stem in position, the sound is clear and resembles the miaow of a cat². When transitions between these two positions are requested simultaneous with normal playing, the wah-wah effect is produced. Additionally, a similar effect can be created by slowly inserting and removing other mutes or slowly opening and closing the bell when hand muffling.

¹ Cf. György Ligeti: Requiem. For soprano solo, two mixed choruses and orchestra. Frankfurt/M. et al. 1965, p. 21.

² Sevsay, Handbuch, p. 143.

3.8.2.1 Previous methods of notation

Normally, the wah-wah effect is notated by utilising the two symbols 'o' (open) and '+' (closed). An example for this method can be found in Berio's *Sequenza XI*¹. He uses the two designated symbols in order to make a trumpet player open and close the bell of his instrument. Moreover, a line is employed in order to outline that there is a transition between the two states:



Fig. 168 Berio, *Sequenza XI*, p. 7.

Lachenmann further augments this method by introducing exact durations. This is executed by utilising the two symbols as note heads. Additionally, he makes use of a *legato* slur, which requests soft transitions between 'o' and '+' [weiche Übergänge zwischen 'o' und '+']:

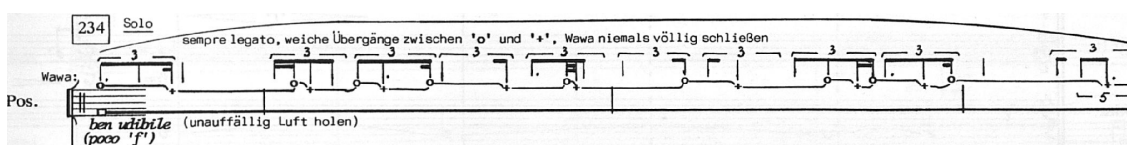

Fig. 169 Lachenmann, *Gefühle*, p. 47.

3.8.2.2 Discussion

The plus and circle symbols are conventionally employed for the depiction of the wah-wah effect. However, as apparent from figure 168, Berio's method of notation is only able to depict the duration of the transition between the open and closed stage by means of the instrumental system (cf. figure 168), whereas Lachenmann's method exactly determines at which point in time the bell is open and closed by means of a distinct

¹ Luciano Berio: *Sequenza XI*. For C trumpet (and resonances of a grand piano). Milan 1984.

timeline (cf. figure 169). Further, the utilisation of an additional *legato* slur even enables the notation of different manners of transition. Therefore, his augmented method is more exact and hence preferred to that of Berio. The only limitation of this method is that neither minims nor semibreves may be employed, but the largest duration is a crotchet. However, since the employed symbols are conventional, they should not be replaced, and because the transition is normally performed in a fast manner, this limitation will not cause fundamental problems.

3. 8. 2. 3 Suggestion for the notation of the wah-wah effect

Hence it is suggested here notating the wah-wah effect by means of the symbols ‘o’ and ‘+’ whilst the duration of the transition between these two states is depicted by using the symbols as note heads. These note heads may be used in a single lined notation system similar to the one employed by Lachenmann. Moreover, articulation symbols, such as the *legato* slur or *staccato* dots, can be used to determine the character of the transition between the two states whilst the mute used to create the effect needs to be described. An alternative method of notation would be to employ the two states in a ‘transposition’ system (cf. figure 130) because notes, as mentioned, suggest that additional sound is produced. However, the original sound is, in this case, actually transformed.

3. 9 Percussive effects

There are two kinds of percussive effects that may be produced on wind instruments, **key/valve clicks or strokes on the body.**

3.9.1 Key/valve clicks

Key/valve clicks can either be executed in addition to the sounding note or as a percussive effect without any blowing. In the case of the latter, the fingered pitches colour the clicks. This articulation may be utilised on all wind instruments with keys or valves.

3.9.1.1 Previous methods of notation

Most commonly, this articulation is notated by means of the traditional notation system and x-shaped note heads¹. An example for such a method of notation can be found in Saariaho's *Laconisme de l'aile*². She depicts pure key clicks by means of x-shaped note heads and additional key clicks by means of a crossed out note:



Fig. 170 Saariaho, *Laconisme*, p. 4.

However, Lachenmann, in *Staub*, makes use of a special note head in order to request key clicks on flutes and clarinets:



Flutes and clarinets: key noise with prescribed fingering

Fig. 171 Lachenmann, *Staub*, no page named [foreword].

Moreover, Varèse, in *Density 21.5*³, places plus signs over tones that are supposed to be complemented by a percussive effect:

¹ Cf. Levine and Mitropoulos-Bott, *Flute*, pp. 26f., Stone, *Notation*, pp. 192f. and Weiss and Netti, *Saxophone*, pp. 177f.

² Kaija Saariaho: *Laconisme de l'aile*. For flute solo with optional electronics. No city and year named [Helsinki 2002].

³ Edgard Varèse: *Density 21.5*. For flute alone. New York 1966.



* Written in January, 1936, at the request of Georges Barrère for the inauguration of his platinum flute. Revised April, 1946. 21.5 is the density of platinum.
 ** Always strictly in time—follow metronomic indications.
 *** Notes marked + to be played softly, hitting the keys at the same time to produce a percussive effect.

Fig. 172 Varèse, *Density*, p. 2.

Further, in order to enable the depiction of diverging dynamic levels for the tone production and the clicks, Gaber, in *Voce II*¹, employs two dynamic levels that are applied simultaneously:

When two dynamics are indicated; i.e., $\frac{P}{f}$, the one below refers to the clicking of the keys.

Fig. 173 Gaber, *Voce II*, no page named [foreword].

3. 9. 1. 2 Discussion

Because x-shaped note heads are most commonly used for the depiction of key clicks as well as for percussive effects (cf., for instance, section ‘2. 7 Percussive effects’), Saariaho’s method of notation (cf. figure 170) is preferred here to Lachenmann’s and Varèse methods (cf. figure 171 and 172). Further, Lachenmann’s approach would have to be augmented in order to enable the depiction of key clicks that complement tones whilst Varèse’s approach could not be employed for the notation of the solely percussive clicks. Moreover, since the percussive clicks and the tone production may be regarded as two distinct sonic events, Saariaho’s method of notation also needs to be slightly elaborated in terms of the notation of the tone and click. In order to depict these sounds as two events, two note heads instead of one combined (crossed out) head would have

¹ Harley Gaber: *Voce II*. Female voice, alto flute, and percussion. Cincinnati 1967.

to be utilised. Further, concerning Gaber's method of employing simultaneous dynamic levels, it may be stated that it is useful to depict the dynamic levels of the two sonic events distinctly. This is because divergent dynamic levels may be employed.

3.9.1.3 Suggestion for the notation of key/valve clicks

Key/valve clicks are suggested here being notated by means of the traditional notation system and x-shaped note heads. When key clicks are used as a complementary effect, two note heads and dynamic levels are employed whilst the purely percussive effect is depicted by utilising only x-shaped note heads. As can be seen in figure 174, a woodwind player is supposed to perform a chromatic semiquaver anabasis from $c^1/C4$ to $g^1/G4$ and a subsequent katabasis to $h/B3$. In the case of the anabasis, the tone (*mezzopiano*) is complemented by key clicks (*pianissimo*) whilst the katabasis consists of coloured key clicks only.



Fig. 174 Key clicks.

The dynamic level of the clicks is, however, limited. For instance in the case of the saxophone, the upper limit is *piano*¹ or on the oboe *mezzopiano*² (and hence the dynamic level requested by Gaber in figure 173 could not be reached). Further, when executing the purely percussive effect on valve instruments, only the valve positions need to be depicted. As mentioned, they can be, for example in the case of the F horn, depicted by means of the (written) pitches $c/C3$ to $F\#/F\#2$ (with the second natural $c/C3$

¹ Weiss and Netti, Saxophone, p. 176.

² Veale, Oboe, p. 139.

the normal range of the F horn begins whilst each of the six possible fingerings lowers it by a semitone).

When playing sustained tones, the percussive effect normally only complements the attack. In such a case, the duration of the x-shaped note heads needs to differ from the duration of the tone. However, key clicks may also sound through a sustained note. In order to do so, a free ‘helping finger’ performs the percussive attack. However, this finger must not influence the sound of the tone in any way¹. This effect can be notated similarly to the enharmonic trill by presenting two fingering charts (cf. section ‘3. 1 Extended *vibrato*, *tremolo* and trill techniques and their notation’). On the basis of such charts it may be depicted which key is used for the percussive effect and that it is released and depressed in a repetitive manner. Additionally, the percussive clicks may on the flutes be performed in combination with a covered embouchure hole. In the case of the concert flute, this results in a coloration that sounds a major seventh lower². As shown in section ‘3. 3. 2 The closed embouchure and its notation’, this kind of embouchure may be requested by giving the direction *al clarinetto*.

3. 9. 2 Strokes on the body

When strokes on the body are requested, the player is normally supposed to hit the mouthpiece (brass instruments) or bell of the instrument with the palm of the hand or his fingers. Moreover, the barrel of certain wind instruments may be struck after removing the mouthpiece. In the case of such strokes, the fingerings may colour and modify the sound that evolves³. Additionally, strokes may be, especially on brass instruments,

¹ Cf. Levine and Mitropoulos-Bott, *Flute*, p. 26.

² *Ibid.*, p. 27.

³ Cf. Rehfeldt, *Directions*, p. 75.

performed on other parts of the body and also be executed by means of items, e. g. mutes or mallets.

3.9.2.1 Previous methods of notation

Concerning the percussive effects, there are various approaches of notation. In *Aventures* Ligeti makes use of a single lined notation system with no clef and x-shaped note heads. He further advises the player to perform a short, sharp blow with the hand on the mouthpiece [mit der Hand kurz und kräftig auf das Mundstück schlagen]:

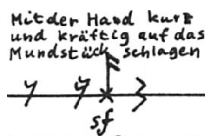

Fig. 175 Ligeti, *Aventures*, p. 6.

Moreover, Lachenmann makes in *NUN*¹ use of a special note head and a bracketed traditional clef in order to depict the strokes and the additional fingerings, which colour the produced sound:

Klarinetten: Schlag auf die obere Öffnung des Instruments bei abgenommenem Mundstück und Birne mit flachgestreckter Handinnenfläche auf die Öffnung schlagen. Die vorgeschriebenen Griffe dienen der Helligkeitsabstufung.

Clarinets: Attack on the upper opening of the instrument with the mouthpiece and tuning socket removed. Use the flat of the stretched hand to strike against the opening. The prescribed fingerings serve to grade the brightness.



Kl., T. 84ff.

Cl., mm. 84ff.

Hörner, Trompeten, Tuben: Schlag aufs Mundstück mit flach gestreckter Hand-Innenfläche (bei Hörnern und Trompeten: vorgeschriebene Ventilstellung beachten). Der Gefahr, daß sich hierbei ein Mundstück festklemmt, kann dadurch begegnet werden, daß letzteres mit feinem Seidenpapier umspannt und so ins Instrument eingesetzt wird.

Horns, trumpets, tubas: Attack on mouthpiece with the flat of the stretched hand. (Horns and trumpets must pay attention to the prescribed valve position). One can avoid the danger of getting a mouthpiece stuck too tightly by wrapping tissue paper around the mouthpiece before placing it into the instrument.



Hn./Trp./Tb., T. 78f.

Hn./Trp./Tb., mm. 78f.

Fig. 176 Lachenmann, *NUN*, p. V.

¹ Helmut Lachenmann: *NUN*. Music for flute, trombone, male voices and orchestra. Wiesbaden 2002.

Further, Alsina, in *Consecuencia*¹, requests a single hit or roll with the mute (whilst Alsina refers to the roll as a trill). As can be seen in figure 177, single strokes are notated by a line added to the note tail and rolls by means of zigzag line that replaces the note head. These notes are utilised in combination with a single lined notation system².

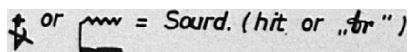

Fig. 177 Alsina, *Consecuencia*, p. 7.

3. 9. 2. 2 Discussion

Strokes on the bodies of wind instruments can be compared to strokes on the bodies of string instruments. As shown in section ‘2. 7. 1 Strokes on the body and their notation’, these can be notated by means of a drawing of the instrument’s body, which enables the determination of the point of impact, in combination with a drawing of the player’s hand. When compared to the methods of notation by Ligeti (cf. figure 175), Lachenmann (cf. figure 176) and Alsina (cf. figure 177), it may be stated that all of these contain a lesser degree of instantaneous comprehension. Further, all methods would have to be augmented in order to enable the depiction of strokes on other parts of the body than the ones they request.

Nevertheless, Ligeti’s method of utilising a single lined notation system with no clef can be described as being closely related to traditional notation in terms of the depiction of the pitchless strokes. This is because strokes with indefinite pitch are commonly notated by x-shaped note heads (cf. the chapter on percussion instruments). However, his approach needs to be complemented by a depiction of the fingering when the bell, mouthpiece or open barrel of the wind instrument is hit. These articulations resemble

¹ Carlos Roqué Alsina: *Consecuencia*. Trombone solo. Berlin and Wiesbaden 1969.

² Cf. *ibid.*, p. 2.

the speaking and playing technique since in both cases a sound with indefinite pitch is coloured by the fingering. As apparent from section ‘3. 5. 2 The speaking and playing technique and its notation’, the technique is notated by means of two notation systems. The fingering is depicted by a common notation system and normal note heads whilst the spoken words are notated by means of a single lined notation system with no clef and x-shaped note heads. Further, the dynamic level of the pitches is designated as ‘∅’ in order to outline that no common blowing is employed. Since the speaking and playing technique and the strokes on the mouthpiece, bell or barrel are strongly related, they could be depicted in the same manner. This approach is preferred here to that of Lachenmann because there is no need to employ special note heads when the percussive action is depicted by an additional notation system and a greater coherence would be achieved. Further, Alsina’s method of replacing the note by a symbol leads, as mentioned, to inexactness. This is because minims or semibreves could not be depicted. Moreover, since a conventional method of notation for rolls already exists (in the form of the *tremolo* symbol)¹, there is no need to introduce a new method for a similar action.

3. 9. 2. 3 Suggestion for the notation of strokes on the body

Two notation systems are employed here, one that depicts the fingering and one that depicts the stroke. Analogous to the speaking and playing technique, the system that determines the pitch is placed on top and the system that determines the strokes on the bottom. As mentioned, the dynamic level of the pitches is designated as ‘∅’ whilst the point of impact and the sound producer is notated by means of a drawing. When the sound producer is the hand, the method of depiction introduced in the string instruments’ figure 92f. may be utilised. When a standard mute is used to execute a stroke, a

¹ Cf. Sevsay, Handbuch, p. 207.

drawing similar to the one employed by Kagel in *Atem* (cf. figure 166) can be used whilst the utilisation of mallets (and special agents of attack) is explained in the chapter on percussion instruments. Further, the removal of the mouthpiece, bell etc. is discussed in section ‘3. 6 Preparing the instrument’.

Percussive effects are displayed here by taking the example of a trumpet. The player is in figure 178 supposed to initially perform four semiquaver strokes on the mouthpiece with the index, middle and ring finger whilst fingering a *c¹/C4*. After a crotchet rest he is then required to hit the bell once with the palm and finger an *a/A3*. Subsequent to a dotted quaver rest, the trumpeter executes four semiquaver strokes with the knuckles on the spot designated by the dot. In the case of these hits, the fingered pitch does not influence the sound and does hence not need to be determined.

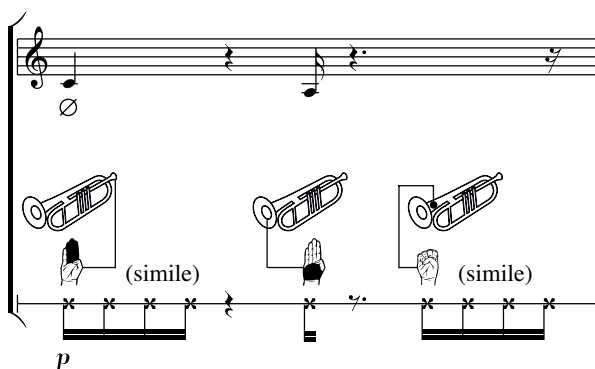

Fig. 178 Strokes on the body of a trumpet.

When strokes on the bell or barrel of woodwinds are performed, the player can only finger the pitches with one of his hands. Nevertheless, the tones may be depicted in the usual way when it is clear which hand is used for the strokes and with which hand the incomplete fingering is executed. This could be outlined by giving an additional direction, such as left/right hand (*mano sinistra/destra*) or alternatively presenting a fingering chart. When executing strokes on parts of the instrument other than the mouthpiece or barrel, only a single lined notation system needs to be employed. Further,

it has to be noted that the strokes have to be performed cautiously in order to preserve the instrument¹. Hence the dynamic level always needs to be low.

3. 10 Resonance effects

Another popular effect is to direct the bell of a wind instrument towards the strings of a grand piano with depressed pedal, a timpano or other percussion instruments. When the wind instrument is then played, sympathetic vibrations are produced. Additionally, it is possible to further modify the sound by moving the bell over the surface of the instrument. However, certain wind instruments, such as the bass clarinet, saxophone, bassoon, tuba etc., are not perfectly suitable for the performance of such effects (but nevertheless sometimes used to produce them). This is because their bell cannot be comfortably directed towards the resonating instrument².

3. 10. 1 Previous methods of notation

Gubaidulina, in *Dots, lines and zigzag*, makes use of resonance effects. She requests these by means of a simple explanation in the foreword of the work: “[a]t the beginning the clarinettist sits at the piano instead of the pianist, and depresses the right pedal”³. When the clarinettist starts playing, the strings of the piano vibrate. Moreover, Lachenmann, in „... *zwei Gefühle ...*“, *Musik mit Leonardo*, notates a similar action in the same manner. However, he gives the directions in the score and not the foreword. In the piece a tubist is supposed to walk to the grand piano [geht zum Flügel] and play into the grand piano [spielt in den Flügel] (which means that he will have to bend over before he starts playing):

¹ Cf. *ibid.*, p. 152.

² Cf. *ibid.*, p. 152.

³ Gubaidulina, *Dots*, p. 2.

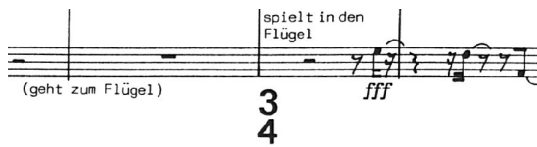

Fig. 179 Lachenmann, *Gefühle*, p. 43.

Further, in Berio's *Sequenza X* a trumpet player is placed behind, which is only used as a resonator¹. When he starts playing, sympathetic vibrations are produced. The disposal of the instruments is, as can be seen in figure 180, depicted by a sketch in the foreword of the work.

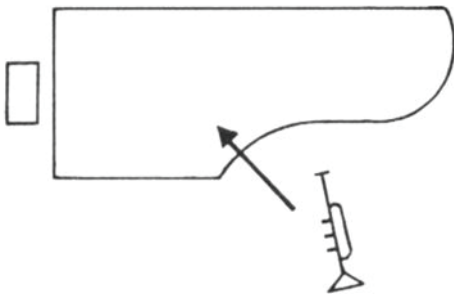

Fig. 180 Berio, *Sequenza X*, no page named [foreword].

Moreover, the action of moving a clarinet's bell over the surface of the piano's bass strings is utilised by Foss in *Echoi*. He employs arrows in order to depict the motions the player is supposed to perform:

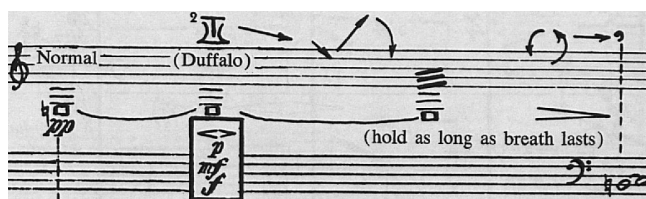

Fig. 181 Foss, *Echoi*, p. 29.

¹ Cf. Berio, *Sequenza X*, no page named [foreword].

3. 10. 2 Discussion

Resonance effects and the action of walking and directing the bell towards the instrument may be adequately notated by means of directions (cf. the example by Gubaidulina and figure 179). These directions can even be longer and hence contain a small degree of instantaneous comprehension. This is because when requested in the course of the piece, the player anyway needs time to prepare the articulation, i. e. to walk to the instrument, before being able to perform it. Alternatively, the positioning of the player can be depicted by means of a sketch (cf. figure 180). Such a sketch could describe the disposal of the instrument in an exact way and even be used to determine the path the player is supposed to walk. Additionally, even the walk itself may be notated and used as the sonic material of a work. Further, the movement of the instrument's bell modifies the resonance effect. It may be, therefore, desirable to depict it. However, Foss notates this action in a very approximate manner (cf. figure 181). As shown below, a more exact method could utilise a drawing of the instrument's body in order to depict the bell's motion.

3. 10. 3 Suggestion for the notation of resonance effects

The suggested method of notation for the resonance effect makes either use of a direction or a sketch, which explains the positioning of the instrumentalist and the paths they are supposed to walk. Additionally, the distance between the bell and the resonating instrument may be determined. The direction or sketch may be presented in the foreword of the work or be a part of the score. An example for a sketch is displayed in

figure 180 and can, for instance, also be found in Szalonek's *Piernikiana*¹ who utilises a piano and a tam-tam as resonators².

Further, the movement of the bell is notated here by presenting a drawing of the instrument's body, dashed lines and arrows that depict the motion. Dashed lines are used in order to outline that the instrument itself is not touched, but the bell merely moved over it. Since no sound is produced by this movement, but the resonating sound modified, no common notes are utilised for the depiction of the motion's duration. Instead, a time related starting point and endpoint (◊) is used to notate the action's duration by means of an additional single lined notation system with no clef placed below the original system. In figure 182 the action of moving an instrument's bell is displayed by taking the example of a piano. In the example, the player is supposed to move the instrument over the surface of the instrument's bass strings. Initially, the player moves the bell from the left to the right for the duration of a crotchet, then remains on this position for another crotchet and subsequently performs a spiral motion for the duration of a minim. Simultaneously, a semibreve *c¹/C4* is played (also cf. section '4. 2. 4 Rubbing and bowing motions' for more complex motions and figure 309 in the chapter on keyboard instruments for the complete illustration of the grand piano's body).

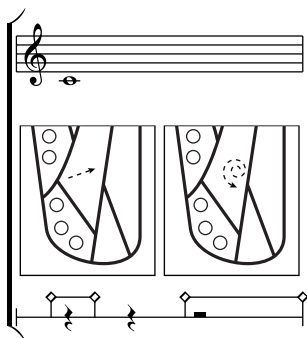

Fig. 182 Resonance effects on the grand piano.

¹ Witold Szalonek: *Piernikiana*. For tube solo. Kraków and Munich 1978.

² Cf. Szalonek, *Piernikiana*, p. 2.

3. 11 Rare extended playing techniques and their notation

There are a couple of rare playing techniques that are explained here separately. One of these is normally referred to as **subtone** and only introduced briefly in this section because a conventional method of notation has already been established. The subtone technique refers to the airy, breathy way of playing lower tones. Subtones are overtone-weak and quiet sounds. This effect can be produced on clarinets and saxophones. It is normally notated by means of the lowest dynamic level and the additional direction *subtone*. In the case of the saxophone, it is difficult to play very quiet in the lower register. Therefore, the articulation is normally realised with the dynamic level *pianissimo*. Transitions between normal and subtone playing are difficult and cannot always be smoothly executed¹. Moreover, similar sounds can be produced on the bassoon. Gallois designates these as **velvet sounds** and explains that these extremely soft sounds resemble the sound colour produced by brass instruments played with mutes. He further suggests notating them by giving the direction *velvet mode*². However, velvet sounds could alternatively be requested in the same way as subtones and hence by giving the direction *velvet sound/tone*.

Further, wind players are occasionally requested to produce the highest possible and sometimes even the lowest possible tone³. This is because the usual range of some instruments may be extended⁴. However, the lowest possible tone is clearly defined for all wind instruments and hence does not need to be specifically requested. A method of notation for the **highest possible tone** has been presented in sections '3. 3. 3 Teeth

¹ Cf. Weiss and Netti, *Saxophone*, pp. 161f.

² Gallois, *Bassoon*, pp. 25f.

³ Cf. Erwin Koch-Raphael: *Spuren*. Tenor trombone solo with optional percussion. Berlin and Wiesbaden 1980, no page named [appendix] and Krzysztof Penderecki: *Capriccio*. For oboe and 11 strings. Celle and Kraków 1968, p. 15.

⁴ Cf. Levine and Mitropoulos-Bott, *Flute*, p. 11 or Weiss and Netti, *Saxophone*, p. 33.

embouchure’ and ‘2. 4. 1 The highest possible tone and its notation’. These paradigms may be easily transferred.

Another extended technique is the **half valve** technique. It may be executed on all brass instruments with valves. When requested, the valves are only supposed to be depressed halfway. The result is a transposition upwards and a modification of the timbre. The articulation is normally notated by means of diamond-shaped notes that replace the common notes¹. Since these are, in the case of wind instruments, only suggested being utilised for the depiction of the woodwinds’ whistle tones (cf. section ‘3. 7 Whistle techniques’), and the pitch is raised similarly to playing harmonics, they may also be employed for the notation of the brass instruments’ half valve technique. Because the utilisation of a diamond-shaped note head already adequately requests this technique, only the fingered tone, but not the resulting pitch needs to be depicted. As mentioned, the system can then be regarded as transposing. Moreover, transitions between normal playing and the half valve articulation can be smoothly executed.

Further, Lachenmann, in *Mouvement (– vor der Erstarrung)*, requests so-called **breath accents**. Flute and trumpet players are in this piece supposed to move the instrument before the mouth and release a stream of air on the blow hole at the appropriate moment. He depicts this effect by means of a special note head:

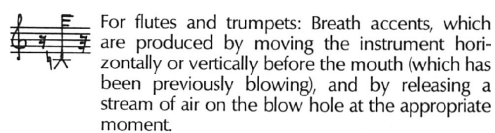

Fig. 183 Lachenmann, *Mouvement*, no page named [foreword].

The articulation described by Lachenmann as breath accents resembles the jet whistle technique. This is because in both cases the sound is created by a strong air attack.

¹ Stone, *Notation*, p. 199 and Sevsay, *Handbuch*, p. 148.

However, in this case, the embouchure may be described as *al flauto dolce* (cf. section ‘3. 3. 4 The recorder embouchure and its notation’), and the instrument is moved. However, since the two techniques resemble each other, and because the breath attack articulation is only rarely utilised, it is suggested notating it in the same manner as the jet whistle instead of by a completely new method. Therefore, breath attacks on the flutes are depicted by means of giving the direction *al flauto dolce* and utilising the same arrow that requests the jet whistle. An additional symbol, which depicts the motion of the instrument, is not used here in order to preserve a clear appearance of the score. In figure 184 the player is supposed to perform a breath attack whilst fingering the tone *c¹/C4*.



Fig. 184 Breath accents.

Further, some composers direct the player to reverse the instrument and **blow into the bell**¹. In such a case, the player is supposed to finger the keys/valves conversely. Due to their unhandiness, this action cannot be performed on large wind instruments. As this technique can be regarded as a rare extended embouchure, it is suggested here requesting it similarly and hence by means of a direction, such as *all'incontrario* (back to front). This articulation may also be performed after removing parts of the instrument or modifying it (cf. section ‘3. 6 Preparing the instrument’). Additionally, woodwind players are also sometimes required to blow through the tone holes². Since this is a very uncommon action, it should be, however, explained by means of a sketch (cf. figure 107 in the chapter on string instruments) and determining the embouchure.

¹ Read, *Contemporary*, p. 147.

² Sevsay, *Handbuch*, p. 151.

Another rare articulation is to either **move the bell of the instrument** up and down or from the left to the right. When the instrument is moved up prior to the blowing, a fanfare is played. When motions are performed during normal blowing, a kind of *Doppler* effect is produced¹. A fanfare is normally requested by means of the direction bells up. However, when the extent and duration of complex motions are supposed to be notated in an exact manner, an additional single lined notation system may be employed. It can be used to depict the extent in degrees and the duration by means of the timeline. Since the action of performing complex motions with the bell is similar to executing motions of the bell over the surface of an instrument, it may be alternatively notated in the same way as in section ‘3. 10 Resonance effects’. However, in this case, the reference instrument is missing. Therefore, the maximum radius of the movement is displayed and the motion drawn into it. Dashed lines are employed here because no instrument is depicted in this case, and the method of notation can hence be clearly distinguished from the method used to depict rubbing motions on percussion instruments (cf. section ‘4. 2. 4 Rubbing and bowing motions’) and resonance effects (cf. section ‘3. 10 Resonance effects’). As can be seen in figure 185, the radius is depicted by a circle, which also contains the home position of the bell. In the example a clarinettist is supposed to perform the motions. Since the clarinet is normally held inclined, the ordinary position is not in the middle of the radius. Initially, the player moves the bell from the home position to the right for the duration of a crotchet, then remains on this position for another crotchet and subsequently performs a spiral motion for the duration of a minim. During these motions a (written) semibreve $c^1/C4$ is played.

¹ Ibid., pp. 152f.

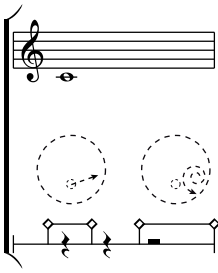

Fig. 185 Moving the bell.

3. 12 Summary

In this part of the work the unconventional playing techniques of wind instruments are introduced, their previous methods of notation discussed and suggestions for their notation presented. In the first section extended *vibrato*, *tremolo* and trill techniques are discussed. These techniques imply the *smorzato* (an oscillating change of the amplitude and timbre), the *bisbigliando* (a change of the timbre) as well as the broken unison *tremolo* – which is executed by repeatedly depressing and releasing the same key(s) or valve(s). Moreover, the next section focuses on extended tongue techniques, including flutter-tonguing, *pizzicato* effects, the slap tongue and tongue ram. The flutter tongue is a standard articulation, but may be performed in two ways: either by rolling the tip of the tongue on the alveolar ridge or the back of the tongue at the uvular. The *pizzicato* effect may be produced by either placing the tongue firmly on the mouth and then, supported by a strong air stream, throwing it to the bottom (tongue *pizzicato*) or pressing the lips tightly together and then ripping them apart (lip *pizzicato*). Further, there are three slap tongue variants, the *secco* slap (only the percussive part of the sound is audible), the standard slap (it has a clear pitch and the typical noise component of the slap tongue) and the open slap (which is complemented by a strong percussive sound produced by dropping the jaw at the moment of the attack). In the case of the tongue ram, the tongue

is either propelled into the embouchure hole/tube or rammed against the reed/mouthpiece/bocal.

The next section is devoted to extended embouchure techniques. One of these techniques is referred to as trumpet embouchure and normally executed on flutes as well as on other woodwinds when playing without reed or mouthpiece. Another technique can be described as closed embouchure and is related to the original clarinet embouchure. It can be only executed on the flutes. Moreover, teeth embouchure is executed by slightly touching the reed of woodwinds and results in high tones of harmonic character. Finally, the recorder embouchure is a rare technique and may not be executed on flutes. If requested, the player is supposed to blow onto the mouthpiece from a short distance. Furthermore, pitch bending is the only unconventional *glissando* techniques of wind instruments. It is executed via changes in lip tension (brass instruments) or embouchure (all woodwinds) and/or closing tone holes (only woodwinds and in a limited manner on some of the flutes). The extent of the *glissando* is, in these cases, dependent on the utilised instrument. In the next section extended blowing techniques are discussed. They include the playing and singing technique (singing while playing), the speaking and playing technique (speaking through the instrument while fingering pitches), whistle into the embouchure hole (whistling while fingering pitches), the air and tone technique (mixing an amount of air with the normal tone) and vocalisation (changing the timbre of the tone by altering the resonance of the mouth cavity). Further, in the case of wind instruments, two main preparations may be executed: detaching the headjoint/mouthpiece/reed/bocal as well as constructional modifications. As in the case of string instruments, numerous constructional modifications can additionally be carried out. Some of the preparations that may result in new playing techniques being created are in this section displayed.

The next section on whistle techniques then comprises a discussion of whistle tones and the jet whistle. Whistle tones are lightly fluctuating tones in the high register and based on the harmonic series while the jet whistle is a short, forceful and loud attack of air, which includes a *glissando*-like raise of pitch. Furthermore, muting can be employed in two ways: either by constantly inserting special mutes/items/the hand into the sound hole of a wind instrument or by applying and removing such mutes repetitively in a fast manner. In the case of the latter, the wah-wah effect is produced. Additionally, two kinds of percussive effects may be produced on wind instruments: key/valve clicks or strokes on the body. Key/valve clicks can be produced in addition to the sounding note or as a percussive effect without any blowing. Strokes on the body imply strokes on the mouthpiece, bell, barrel or the body itself. In the next section resonance effects are discussed. When requested, the player is supposed to direct the bell towards the string of a piano with depressed pedal, a timpano or other percussion instruments. Sympathetic vibrations are produced when the wind instrument is then played. Finally, rare techniques, such as subtones and velvet sounds (overtone-weak and quiet sounds), the highest possible tone, the half valve articulation (transposition upwards and modification of the timbre), breath accents (move the instrument before the mouth and release a stream of air at the appropriate moment), blowing into the bell as well moving the bell of the instrument, are discussed.

4. THE TECHNIQUES OF PERCUSSION INSTRUMENTS

There are four groups of percussion instruments: idiophones, membranophones, chordophones and aerophones. When producing sound on idiophones, the whole body of the instrument is caused to vibrate. Idiophones may have a definite pitch (e. g. mallet instruments, tubular bells, cymbales antiques), indefinite pitch (e. g. cymbals, tam-tams, triangles) or a slightly perceptible pitch (e. g. temple blocks, wood blocks). Membranophones are either single-headed (e. g. timpani, bongos, timbales) or two-headed (e. g. snare drums, bass drums) while the membrane is stretched over a soundbox. These types of drums may also produce sounds with definite pitch (e. g. timpani, rototoms), indefinite pitch (e. g. snare drums, bass drums) or slightly perceptible pitch (e. g. tomtoms, bongos). Further, when producing sound on chordophones, strings are caused to vibrate. All string, plucked and keyboard instruments are referred to as chordophones. Besides these, there is only one instrument that is considered to be a percussion instrument: the cimbalon. On aerophones tones are produced by causing an air column to vibrate. All wind instruments are part of this group whilst some aerophones are regarded as percussion instruments (e. g. slide whistles, wind machines, vehicle horns)¹. There is a huge variety of percussion instruments. The aim of this chapter is, however, not to focus on every single instrument, but to discuss unconventional extended playing techniques of percussion instruments in a general manner. Therefore, it is structured by playing techniques and not grouped by instruments. Most of the examined techniques may be applied on idiophones and/or membranophones.

With regard to percussion instruments, the notation of rolls, the *vibrato* (which is, for instance, on cymbales antiques produced by waving the hand over the instrument subse-

¹ Sevsay, Handbuch, pp. 157, 171 and 202f.

quently to the attack or on clash cymbals by shaking these after the attack)¹, trills, clusters (on mallet instruments, also cf. section ‘6. 6. 1 Clusters’), the basic *glissando* (which is, for instance, on timpani produced by means of the pedal), normal attacks (e. g. striking, shaking or activating the instrument), the production of harmonics (e. g. on the vibraphone) and other basic articulations, such as turning the motor of a vibraphone on/off or changing the speed of the fan, are regarded here as conventional elements². Their notation can be accessed through the essential handbooks on instrumentation whilst most composers use the method of depiction that can be found there. Moreover, the determination of the standard agents of attack, i. e. which mallet the percussionist is supposed to use, and their basic utilisation, i. e. how many mallets he holds in his hands, is not discussed here. A virtually conventional approach towards the notation of these parameters can be found in Adler³, Sevsay⁴ or Stone⁵ whilst the explanation by Sevsay is the most complete one and, therefore, recommended here. The cimbalon is also not discussed here. However, some of the extended playing techniques explained in the chapter on plucked and keyboard instruments, such as percussive effects, *pizzicato* on the neck or playing on the strings of a piano, may be easily transferred to this instrument. Further, an approach towards the notation of whistles is presented in section ‘3. 6. 1 Detaching the head joint/mouthpiece/reed/bocal and its notation’. Whereas, the main unconventional elements discussed in this chapter are the extension of the percussive apparatus, extended modes of attack, ‘pitch’ bending – the extended *glissando*, muting as well as preparing the instrument. As the number of

¹ Ibid., pp. 180f.

² Cf. *ibid.*, pp. 159-207.

³ Adler, *Orchestration*, pp. 434f.

⁴ Sevsay, *Handbuch*, pp. 214-216.

⁵ Stone, *Notation*, pp. 210-213.

percussion instruments is vast, indications concerning the limitation of the dynamic level, in most cases, may not be presented.

4.1 The extension of the percussive apparatus

The percussive apparatus can either be extended by introducing **special agents of attack** or **percussion instruments**. There are various examples for the two varieties.

4.1.1 Special agents of attack and their notation

Theoretically, any kind of item a percussionist is able to hold in his hands can be used as a mallet. Therefore, the number of special agents of attack is vast. Examples of such items can be, for instance, found in Lachenmann's *Staub*. There he makes use of a cardboard tube in order to produce sound on a tam-tam. The utilisation of this kind of mallet is requested by giving the direction cardboard tube [Papprohr]¹. Moreover, in *Concertino* Szalonek utilises inter alia a tuning fork to strike a rubber plate and subsequently touch an instrument with it². The tuning fork is notated by means of a symbol:

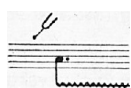

Fig. 186 Szalonek, *Concertino*, p. 3.

Further, Kagel, in *Dressur*³, makes use use of a carpet beater, which is also introduced by means of a symbol:

¹ Cf. Lachenmann, *Staub*, p. 85.

² Cf. Szalonek, *Concertino*, p. 3.

³ Mauricio Kagel: *Dressur*. Drum trio for wood instruments. Frankfurt/M. et al. 1983.



1 *carpet beater* made of basket-work

Fig. 187 Kagel, *Dressur*, no page named [foreword].

As mentioned in the previous section, there is a general method of notation for the standard agents of attack. In this method the mallets the percussionist is supposed to employ are depicted by means of symbols. In order to comply with the conventional manner of depicting agents of attack, special mallets should be notated in the same fashion. Therefore, Szalonek's and Kagel's approaches are preferred to Lachenmann's approach. Hence any special agent of attack is suggested here being introduced by means of a symbol. The more this symbol resembles the shape of the mallet, the greater the degree of instantaneous comprehension and simpler the method of notation. However, since there is a vast number of special agents of attack, symbols for all possible mallets cannot be presented here, and the utilisation of the hand as an agent of attack is discussed in section '4. 2. 1 The extended utilisation of the agents of attack'.

Further, even percussion instruments are sometimes utilised as mallets. In *Anagrama*¹ Kagel, for instance, uses claves, güiros, maracas or triangles to strike percussion instruments². These instruments are, however, not introduced by symbols, but directions. In order to depict the mallets in the same manner as the standard and other extended agents of attack, symbols would have to be employed. Examples for graphic

¹ Mauricio Kagel: *Anagrama*. For four solo singers, speaking choir and chamber ensemble. London 1965.

² Cf. Kagel, *Anagrama*, pp. 7 and 23.

representations of percussion instruments can be, for example, found in Sevsay¹, Stone², Kagel's *Match*³ and *L'art bruit*⁴ or Stockhausen's *Kontakte*⁵.

4. 1. 2 Special percussion instruments and their notation

As in the case of the special agents of attack, any non-instrumental item that can be struck, shaken or used to produce any kind of sound, extends the percussive apparatus. Therefore, a coherent method of notation for all possible augmentations cannot be presented here. Further, such non-instrumental sound sources are suggested rather being discussed in a followup work on sound recording. This is because it is, as mentioned, a very extensive topic. Furthermore, there are also non-instrumental sounds that can only become part of a musical work by recording them since they cannot be removed from their environment. Hence in order to jointly discuss these types of sounds, an approach towards the notation of special percussion instrument is not presented here. Moreover, percussive sounds that can be created on other orchestral instruments are discussed separately in the chapter on the respective instrument.

4. 2 Extended modes of attack

In this section **the extended utilisation of the agents of attack, extended striking techniques**, the problem of **determining the point of impact** as well as **rubbing and bowing motions** and **the sound production without agents of attack** is discussed. Finally, **playing the snares** of a drum is especially examined. This is because a number of special techniques may be employed when playing a snare drum in this way.

¹ Sevsay, Handbuch, pp. 212f.

² Stone, Notation, pp. 206-210.

³ Kagel, *Match*, pp. 2f.

⁴ Mauricio Kagel: *L'art bruit*. Solo for two. Frankfurt/M. et al. 1998, pp. If.

⁵ Karlheinz Stockhausen: *Kontakte*. For electronic sounds, piano and percussion. London 1966, pp. 3-6.

4.2.1 The extended utilisation of the agents of attack

The agents of attack are used in an augmented manner when a strike is executed with the handle of the beater, a percussion instrument is struck with the entire length of a stick, one of the ends of the the beater is used to touch an instrument at right angles as well as when the agent's point of contact differs from the normal one or is shifted during the execution of several strokes.

4.2.1.1 Previous methods of notation

The utilisation of the handle is requested in various works. Most composers depict this way of striking the instrument by means of a reversed mallet symbol. For example, Redel, in *Musik für Klavier und Schlaginstrumente*¹, requires the player to strike with the wood handle of the respective beater [mit dem Holzende des jeweiligen Schlegels] by utilising this method of notation:

 = mit dem Holzende des jeweiligen Schlegels

Fig. 188 Redel, Musik, p. 2.

However, sometimes, for instance, the direction with handle [mit Stiel]² or with wood handle [mit Holzstiel]³ is given. Moreover, Penderecki, in *Dimensions of time and silence*, requests this articulation by marking the handle end of the drumstick:

strike the instrument with
the handle end of the
drumstick 

Fig. 189 Penderecki, Dimensions, p. 4.

¹ Martin Redel: Musik für Klavier und Schlaginstrumente. Berlin and Wiesbaden 1970.

² Cf. Kelemen, Changeant, p. 56.

³ Cf. Stockhausen, Kontakte, p. 18.

Further, Varèse, in *Offrandes*¹, makes the player “strike the head of drum with entire length of stick”² by giving this direction in a footnote³ whilst the action of touching an instrument at right angles is requested by Lachenmann in *Accanto*⁴. He depicts it by means of the direction dabbed with the handle by attaching the wooden handle end perpendicularly [mit Stiel getupft durch senkrechtliches Aufsetzen des hölzernen Stiel-Endes]:

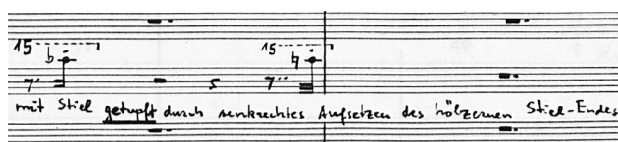

Fig. 190 Lachenmann, *Accanto*, p. 2.

Moreover, Kagel, in *Match*, requests this articulation by means of a symbol for the mallet, an arrow pointing downwards and the additional direction with handle vertical on the cup [mit Stiel vertikal auf Kuppe]:



Fig. 191 Kagel, *Match*, p. 23.

Further, in the same piece he makes the player hit the edge of two cymbals with the middle point of the agent’s handle. This action is depicted by means of a drawing and the additional direction attack perpendicular to the cymbal’s edge [senkrecht zum Beckenrand anschlagen]:

¹ Edgard Varèse: *Offrandes*. For soprano and chamber orchestra. New York 1927.

² Varèse, *Offrandes*, p. 31.

³ Cf. *ibid.*, p. 31.

⁴ Helmut Lachenmann: *Accanto*. Music for a clarinetist with orchestra. Wiesbaden 1984.

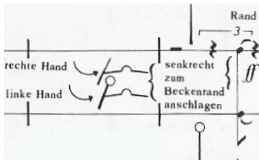

Fig. 192 Kagel, Match, p. 23.

Moreover, Lachenmann, in *Accanto*, requests the percussionist to shift the point of contact between a stick and a xylorimba during the execution of several strokes. This action is requested by means of the direction shift the stick's point of contact to the handle [Anschlagstelle des Stockes zum Schaft verlagern] and notes that underline the agent's motion:

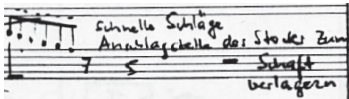

Fig. 193 Lachenmann, Accanto, p. 18.

4. 2. 1. 2 Discussion

As mentioned, the agent of attack is conventionally depicted by means of a symbol. Hence this symbol needs to be also employed when a mallet or stick is utilised in an extended manner. When requesting any of the augmented techniques, the articulations may be either notated by altering the symbol or giving an additional direction. However, an additional direction needs to be limited to a few words in order to guarantee instantaneous comprehension. Therefore, the direction by Varèse (strike the head of drum with entire length of the stick) and the direction by Lachenmann (dabbed with the handle by attaching the wooden handle end perpendicularly) cannot be used to request augmented actions. Further, since simple drawings contain a greater degree of instantaneous comprehension, and hence facilitate the comprehension of the requested technique, this method of depiction is preferred here to giving an additional direction.

Concerning the utilisation of the agent's handle, it is thus favoured to depict the action by means of an extended beater symbol than by the direction with handle or with handle end. Moreover, with regard to the displayed methods of notation, it may be stated that Redel's method (cf. figure 188) is simpler and clearer than that of Penderecki (cf. figure 189). This is because the former approach refers to the way the player holds the mallet or stick and when the normal utilisation of the mallet is depicted by a drawing in which the tip of the agent is on top and the handle end on the bottom, it is consequent to depict the utilisation of the agent in a reversed manner by a drawing in which the handle end is on top and the tip on the bottom.

Furthermore, since Varèse's direction does – as mentioned – not comply with the requirement of enabling instantaneous comprehension, an alternative method of notation needs to be developed in order to depict the action of striking the instrument with the entire length of the agent. Such a method is presented in the following section. Concerning the performance of a perpendicular hit, it may be stated that Kagel's approach (cf. figure 191) does not agree with the suggested method of notation for the reversed utilisation of the mallet. If it was transferred to his approach, the arrow would have to point upwards (in order to request the execution of a vertical stroke by means of the agent's handle). But this would in turn cause confusion because percussionists normally move the mallet downwards when performing such a stroke. Alternatively, an arrow could be used to depict the point of contact on the agent instead of the motion the player is supposed to perform.

With regard to the augmented determination or shift of the agent's point of contact, the depiction by means of a simple drawing (cf. figure 192) is also preferred here to notating the action by means of a direction (cf. figure 193). However, it is not necessary that this image contains a graphic depiction of the agent and the percussion instrument

when only the agent is used in an augmented manner (cf. section '4. 2. 3 The point of impact' for the augmented determination of the point of impact, such as striking the edge of a cymbal). Therefore, it is preferred here not to notate the described articulations in reference to the instrument, but solely by means of a depiction of the mallet. As can be seen in the following section, the exact determination of the point of contact and shifts may be notated by means of arrows.

4. 2. 1. 3 Suggestion for the notation of the extended utilisation of the agents of attack

All augmented utilisations of the agents of attack are depicted by means of a symbol for the mallet the percussionist employs. The beater utilised in the example is a wooden headed drumstick¹. All strokes are depicted by means of x-shaped note heads and a single lined notation system with no clef. This is because the hits are executed here on a percussion instrument with indefinite pitch, which is notated in this manner in order to distinguish these kinds of instruments from the ones with definite pitch. Alternatively, a drum clef system and x-shaped note heads could be employed to enable the simultaneous depiction of strokes on several instruments by means of a single system.

In figure 194 eight distinct articulations are depicted in the order of 1. a normal stroke which implies the determination of the agent of attack (conventional method of notation), 2. a stroke with the handle, 3. a stroke with the entire length of the beater, 4. a stroke which involves touching the instrument at right angles with the stick's tip, 5. a stroke which involves touching the instrument at right angles with the stick's handle end, 6. a stroke where the agent's point of contact is determined as the middle of the stick length and 7. six semiquaver strokes where the agent's point of contact is shifted from the tip to the handle (depending on the percussion instrument, articulation six and

¹ Cf. Sevsay, Handbuch, p. 214.

seven need to be complemented by a depiction of the point of impact on the instrument). As can be seen in the example, the point of contact is determined by an additional arrow when it differs from the normal utilisation of the beater. This is the case in articulation four to seven. However, this method cannot be applied to articulation three since the agent's point of contact is not a single point, but the whole surface of the stick. Therefore, a curly bracket is utilised. Moreover, the shift of the stick's point of contact is notated by an arrow as used for the depiction of all *glissando* actions in this work. However, since the shift only resembles a *glissando* – because the stick does not actually slide – the additional direction *glissando* is dismissed. Alternatively, the exact point of contact for every stroke could be determined. Further, the arrows that depict the point of contact could alternatively point in the direction of the motion. However, this might – as mentioned – cause confusion with regard to articulation four and five. Another rare extended utilisation of the agents of attack is 8. to hit two beaters against each other (clap). This articulation is depicted here by crossing two beater symbols.

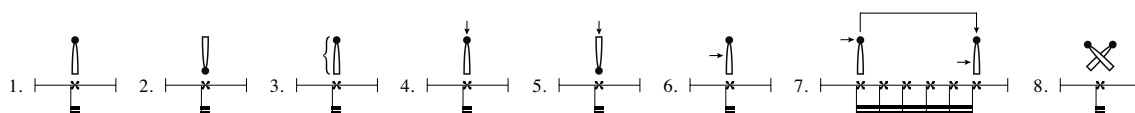

Fig. 194 The normal attack and the extended utilisation of the beater.

The displayed methods of notation can also be transferred to any special agent of attack. However, when the hand is used to attack the instrument, another method of notation needs to be employed. This is because the articulations that may be performed by means of the hand are more complex than the actions that may be executed by means of a mallet or stick. The utilisation of the hand as an agent of attack has already been discussed in section ‘2. 7. 1 Strokes on the body and their notation’ by taking the example of string instruments. Since the action of striking the body of, for instance, a

cello resembles the action of striking any kind of percussion instrument, the method of notation introduced in this section may be transferred. Therefore, the drawings presented in the string instrument's figure 92 and 93 serve here as a paradigm for the utilisation of the hand as an agent of attack and an extensive discussion of the execution of this playing technique on percussion instruments is dismissed. Moreover, when the player is supposed to clap his hands, two hand symbols should be crossed.

4.2.2 Extended striking techniques

Most extended striking techniques are related to the augmented bowing techniques *saltando*, *balzando* and *gettato* discussed in section '2.3.3 The *saltando*, *balzando* and *toccato* and its notation'. When applied on percussion instruments, the utilisation of the beater resembles the *col legno* performance of these techniques. Moreover, the conventional bowing technique designated as *gettato* may also be executed by means of mallets or sticks.

4.2.2.1 Previous methods of notation

The four 'bowing techniques' are only seldom applied. However, for instance, Lachenmann makes in *NUN* use of an action designated by him as *saltando glissando*. As in the case of the *saltando* on string instruments, the beater shakes after the striking. Further, this articulation is combined with a shifting of the point of contact between the head of the beater and the proximity to the shaft. Lachenmann requests the action by means of the direction trill/mordent [Praller] and a line which depicts the *glissando*:



Fig. 195 Lachenmann, NUN, p. VIII.

Moreover, Kagel, in *Anagrama*, requests a *toccato* articulation on a gong by means of the direction touch the gong with no attack [ohne Anschlag den Gong berühren], a diamond-shaped note head and a zigzag line. Since the gong still vibrates from the previous attack when it is touched, a sizzle effect¹ is produced:



Fig. 196 Kagel, *Anagrama*, p. 23.

4. 2. 2. 2 Discussion

With regard to the striking techniques related to the four bowing techniques *saltando*, *balzando*, *toccato* and *gettato*, it may be stated that there is no necessity to introduce a method different from the one employed for string instruments in order to request these. Thus these articulations may be, in the case of percussion instruments, depicted by means of additional directions. When doing so, the articulations are coherently depicted and the method closely related to traditional notation. Therefore, the approaches by Lachenmann (cf. figure 195) and Kagel (cf. figure 196) are dismissed here in favour of the methods introduced in the chapter on string instruments and the conventional manner of depicting the *gettato* articulation. Moreover, the action referred to as *saltando*

¹ A similar sound effect also occurs in the case of the *buzz-pizzicato* because the lingering string is touched with the fingernail or fingertip (cf. section '2. 6. 2 Exact muting stops and their notation').

glissando by Lachenmann needs to be labelled differently. As shown in the respective section in the chapter on string instruments, the direction *saltando* refers to a dense shake without any horizontal motion. As Lachenmann wants the player to shift the point of contact during the *saltando* stroke, the additional direction *glissando* and a line is employed. However, this performance of a *saltando* may be rather described as a *gettato* articulation. This is because the *gettato* is basically a *saltando* that involves a horizontal bowing motion. When transferred to beater attacks, the player shifts the point of contact from the proximity to the shaft to the head of the beater (when executing a normal stroke) or the other way round (when executing a stroke with the handle) by ‘throwing’ the agent of attack. Further, concerning Kagel’s method of notation it may be said that diamond-shaped note heads are, in the case of the *col legno toccato* on string instruments, only employed in order to determine the exact point of attachment on the fingerboard of a string instrument. However, since this point needs to – as shown in section ‘4. 2. 3 The point of impact’ – be, in the case of percussion instruments, determined in another way, the utilisation of these note heads in combination with the *toccato* articulation would lead to confusion. Moreover, there is no need to utilise an additional zigzag line when the articulation is already clearly depicted by means of the direction *toccato*.

4. 2. 2. 3 Suggestion for the notation of extended striking techniques

The extended striking techniques are hence suggested being notated by means of the additional directions *saltando*, *balzando*, *toccato* or *gettato*. These directions may complement the method of depiction for the agents of attack presented in figure 194. The *gettato* may be regarded as a variant of the extended attack, which involves a shifting of the point of contact (cf. attack no. 7). However, in this case, only one stroke

is performed. It implies a dense shake of the beater on the percussion instrument and a simultaneous shifting of the point of contact.

4. 2. 3 The point of impact

Any spot of a percussion instrument may be struck in order to produce sound. Besides the normal attacks, for instance, the middle or edge of the surface as well as the rim or shell of membranophones may be hit. Further, it is possible to gradually shift the point of impact and to simultaneously strike different spots on the same instrument with a single or more beaters. Moreover, the back of certain idiophones and items or beaters lying on the instrument can be struck.

4. 2. 3. 1 Previous methods of notation

In the case of membranophones, most composers differentiate between five (normal attack on the head, middle, edge, rim and shell) or fewer points of impact. In *Intégrales*¹ Varèse, for instance, requests the player to either hit the head [membrane], rim [rebord] or shell [caisse] of the instrument by giving the additional direction M, R or C² and in *Hyperprism*³ only distinguishes between the rim and head⁴. Moreover, Zimmermann, in *Canto di speranza*⁵, utilises two symbols in order to request strokes in the middle or at the edge of the skin:

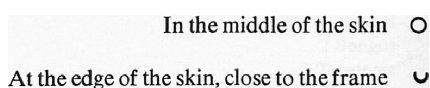

Fig. 197 Zimmermann, *Canto*, no page named [foreword].

¹ Edgard Varèse: *Intégrales*. For small orchestra and percussion. No city named 1926.
² Cf. *ibid.*, p. 1.
³ Edgard Varèse: *Hyperprism*. For small orchestra and percussion. New York 1966.
⁴ Cf. *ibid.*, p. 1.
⁵ Bernd Alois Zimmermann: *Canto di speranza*. Mainz 1958.

However, Sevsay suggests depicting the point of impact by means of using different note heads in combination with a drum clef¹, and Stockhausen, in *Zyklus*², simply requests the player to constantly vary the point of impact when striking the gong or tam-tam³. Further, Lachenmann, in *Staub*, utilises squared note heads to depict shell attacks on timpani and differentiates between higher and lower sounds. Therefore, the notes are employed in a five lined notation system with no clef while the higher the sounds are, the higher is the position of the note in the system:

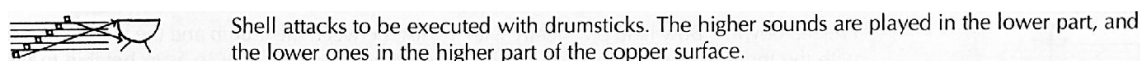

Fig. 198 Lachenmann, *Staub*, no page named [foreword].

Another method of notation is employed by Kotoński in *A battere*⁴. He makes use of a graphic depiction in order to determine the point of impact on the instrument:

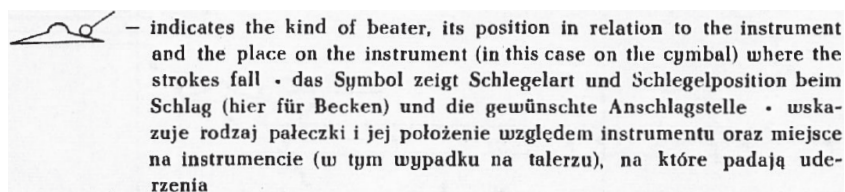

Fig. 199 Kotoński, *Battere*, p. 3.

Moreover, Redel, in *Rounds*⁵, requests a gradual shifting of the point of impact from the edge [Rand] to the middle [Mitte] by means of the letters ‘R’ and ‘M’ as well as an arrow:

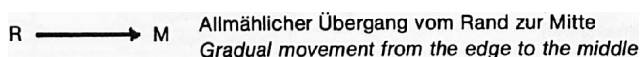

Fig. 200 Redel, *Rounds*, no page named [appendix].

¹ Cf. Sevsay, *Handbuch*, p. 160.

² Karlheinz Stockhausen. *Zyklus*. For one percussionist. London 1961.

³ Cf. *ibid.*, no page named foreword.

⁴ Włodzimir Kotoński: *A battere*. For percussion, guitar, harpsichord, viola and violincello. Celle 1963.

⁵ Martin Redel: *Rounds*. For percussion solo. Berlin and Wiesbaden 1979.

Furthermore, Varèse, in *Ionisation*¹, requests a (non-specified) rim shot by means of placing letter 'R' above the note head:

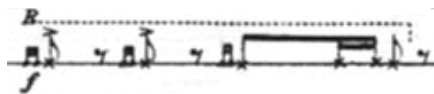

Fig. 201 Varèse, *Ionisation*, p. 21.

In *L'art bruit* Kagel also makes the player strike a Chinese cymbal from underneath.

This action is requested by means of a graphic depiction:

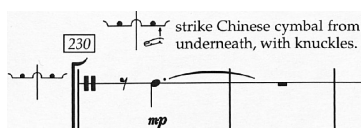

Fig. 202 Kagel, *Bruit*, p. 11a.

Finally, Penderecki in *Fluorescences*² requests a hit on a drumstick lying on the surface of a percussion instrument by means of a variation of the symbol he employs to depict the drumstick:

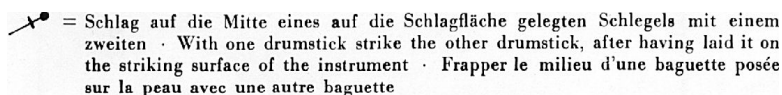

Fig. 203 Penderecki, *Fluorescences*, p. 3.

4. 2. 3. 2 Discussion

When only a very limited number of points on a percussion instrument are supposed to be struck, the methods of notation utilised by Varèse and Zimmermann (for the latter cf. figure 197) are sufficient. When the percussionist is supposed to quickly switch instruments, it would be, however, clearer to make use of Sevsay's method and hence depict

¹ Edgard Varèse: *Ionisation*. For percussion ensemble of 13 players. New York 1958.

² Krzysztof Penderecki: *Fluorescences*. For orchestra. Celle 1962.

the point of impact by means of the note head itself and a drum clef system instead of by placing letters or symbols above the notes. This is because attacking one or the other instrument could be simply requested by placing the note head on another line. An example of this method of notation is given in the following section. However, very complex attacks could not be depicted in this manner since the introduction of numerous new directions, symbols or note heads would not comply with the requirement of simplicity. For instance, the six points Lachenmann makes the player strike (cf. figure 198) could not be depicted in a simple way by means of directions. However, Lachenmann's method of introducing special note heads for shell attacks and a notation system derived from pitch-based notation would also become confusing if it was utilised for the notation of all points of impact on all sorts of percussion instruments. Many different variants of this system would have to be introduced in order to depict the point of impact on percussion instruments of different shape and size, which would also in turn lead to a very complex method of notation.

Further, the graphic depiction of the point that is supposed to be struck can be described as simple. Additionally, it contains a great degree of instantaneous comprehension. However, in order to display more than one dimension, the graphic depiction of the instrument's side, as utilised by Kotoński (cf. figure 199), would have to be replaced by a top view of the instrument. Such a method of notation could also be used to display a gradual shift of the point of impact, e. g. from the edge to the middle (cf. figure 200) as well as more complex shiftings, rim shots (cf. figure 201) and – if slightly modified – shell attacks in a simpler manner than by using letters, arrows (and/or symbols) as well as a distinct notation system and special note heads. However, concerning the notation of hits on a cymbal from underneath (cf. figure 202), a variant of depiction would have to be introduced in order to clearly distinguish the front and back of the cymbal.

Moreover, as in the case of Kotoński's approach, the side view would have to be replaced by a 'top' view. Further, concerning the method of notation for hits on a beater or item lying on the surface of a drum (cf. figure 203), it may be said that Penderecki's approach could lead to confusion. This is because when employing a graphic depiction of the drum's surface in order to notate the point of impact and different beater symbols in order to notate the manner of attack, a variation of the beater symbol would suggest rather employing another extended attack instead of striking a 'modified' drum surface. Therefore, a simpler and clearer method would include the beater or item in the graphic depiction of the instrument.

4. 2. 3. 3 Suggestion for the notation of the point of impact

As mentioned, a limited number of points on percussion instruments can be depicted by means of employing different note heads. When using these in combination with a drum clef system, each spacing between the lines or (additionally) each line refers to a particular instrument¹. As the common attack (on instruments with indefinite pitch) is requested by means of x-shaped note heads, these note heads could be, in such a case, also used to depict the common attack whilst, for example, triangular note heads pointing upwards could be used to request attacks on the edge, spherical note heads to notate hits on the rim (only membranophones), triangular note heads pointing downwards to depict strokes on the shell and squared note heads in order to make the player strike the midpoint of the instrument/the dome. When employing instruments with definite pitch, the drum clef system would have to be replaced by a pitch-based

¹ Cf. Iannis Xenakis: *Rebonds*. Paris 1991, p. 1 or Iannis Xenakis: *Dmaathen*. For oboe and percussion soloists. Paris 1976, p. 1.

notation system and the x-shaped note head by a common one whilst the other note heads could be used in the same manner.

However, in the case of more complex attacks, the point of impact on percussion instruments is suggested here being notated by means of a graphic depiction of the instrument. This method can be employed for the notation of complex hits on the surface of membranophones, many idiophones or special percussion instruments. In the example presented in figure 204, the player is supposed to perform six semiquaver strokes on a bass drum, which are followed by a semibreve roll. The beater is again a wooden headed drumstick and the roll executed with two sticks. The first three hits are normal attacks on a point close to the edge, on the rim and on the edge. The next two hits are performed with the entire length of the stick and the last semiquaver stroke is executed with the stick's tip. It hits the middle of the drum at right angles. Finally, the roll involves a complex gradual shifting of the point of impact in the direction of the arrow. In order to facilitate the performance, the graphic depiction of the surface and hits is always regarded as being the percussionist's perspective (also cf. figure 194).

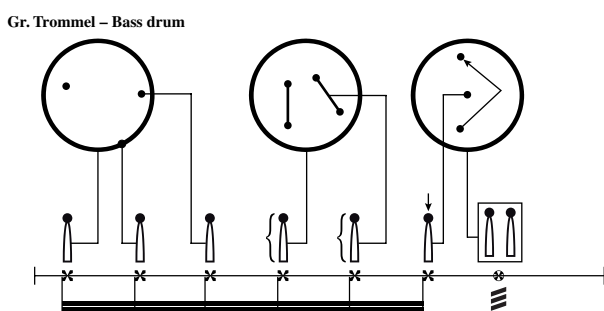

Fig. 204 Complex attacks on a bass drum.

Suchlike graphic depictions may either be employed in a uniform size or correspond to the actual size of the utilised instruments, e. g. when utilising several different membranophones. The former method is less exact, but enables a simpler hand-ling of the illustrations. Moreover, a similar method of notation can also be employed for mallet

instruments in order to depict gradual changes of location and varying points of impact on the bars. When doing so, it is sufficient to solely present drawings of the bars that are actually struck. The depicted size of the bars may remain the same as long as only single tones are played because the percussionist should be able to transfer the notated point of impact to any of the bars, considering their actual size. However, when requesting chords, the higher tone's bar needs to be smaller than the lower tone's bar or, alternatively, be complemented by an additional depiction of the pitch in order to clearly outline which point of impact is related to which tone. Further, when notating the point of impact on güiros, slit gongs, cowbells etc., different graphic depictions need to be utilised.

Shell attacks can be notated by means of a graphic depiction of this part of the instrument. In figure 205 the method of notation for these attacks is presented by taking the example of a timpano. Six semiquaver strokes are performed on its body. All six hits are normal attacks. The first five strokes are executed on various points of the shell. Subsequently, the percussionist is supposed to hit the metal frame of the timpano. Further, in *Accanto* Lachenmann, for instance, requests the player to hit the tuning screw of a timpano¹. In order to notate such an action, the graphic depiction of the kettledrum would have to be more detailed and contain this part of the instrument (also cf. section '2.5 Playing exceptional spots' and all sections on percussive effects).

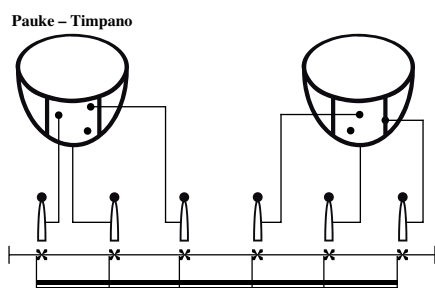

Fig. 205 Hitting the shell of a timpano.

¹ Cf. Lachenmann, *Accanto*, p. 12.

Strokes from underneath are notated here similarly to strokes on the front. However, it is outlined that the back is supposed to be hit because the instrument is coloured black (and the dots, therefore, white). Hence in figure 206 the first three strokes are executed on the front and the last three strokes on the back of a cymbal.

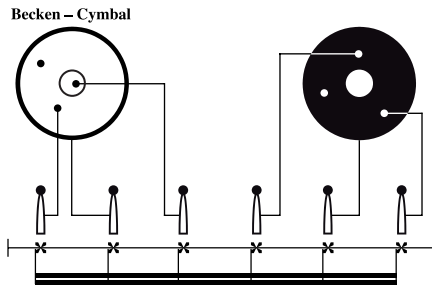

Fig. 206 Strokes on the front and back of a cymbal.

Moreover, hits on beaters or items lying on the surface of the instrument are notated here by extending the drawing of the percussion instrument. In the example presented in figure 207, a stroke on a drumstick lying on the surface of an instrument is depicted. However, the placement of any kind of item on the surface may be notated by replacing the drumstick with another distinct symbol, e. g. for a comb, spoon, book etc.

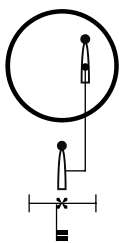

Fig. 207 Striking a drumstick lying on the surface of an instrument.

Further, simultaneous hits on different spots of the same instrument are depicted here by means of the conventional method of notation for the utilisation of the mallets and determining which mallet is used to strike which spot on the head (which is especially important when using two or more different mallets):

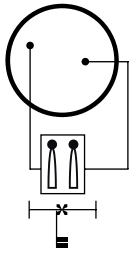

Fig. 208 Striking different spots simultaneously.

Additionally, rim shots may be performed in various ways. In figure 209 six different variants are displayed. The first stroke is executed with the entire length of the stick. However, other than in figure 204, the stick only hits two distinct points. This is depicted by connecting these by means of a dashed line. Further, rim shots which involve a shifting of the point of impact – as requested by Lachenmann in *Accanto*¹ – can be depicted by combining the method of notation for the rim shot (two dots and a dashed line) and the gradual shifting (two dots and an arrow). In the example the player is after the first hit supposed to perform four semiquaver rim shots which involve a shifting in the direction of the player. Subsequently, a (one-handed) crotchet roll, which involves a shifting in the other direction, is executed. Other variants of the rim shot are to hit a drumstick lying on the head and rim, to place the tip of the beater on the head and strike the rim with the shaft or to place the tip of a drumstick on the head and subsequently hit its shaft with another beater². These three attacks follow the shifting. The first variant may be notated in the same way as the action of striking a drumstick lying on the surface of an instrument (cf. figure 207). However, the other two variants require other methods of notation. As can be seen in figure 209, the player is, subsequently to the hit on the drumstick lying on the head and rim, requested to touch the surface with the stick's head (*toccato*) and then hit the rim with the shaft (*ordinario* while another vari-

¹ Cf. Lachenmann, *Accanto*, p. 37.

² Sevsay, *Handbuch*, p. 193.

ant would be to employ the direction *battuto*). Since the *toccato* action does not end before the rim is struck, two ‘transposed’ notes are used to depict the actions (cf. section ‘4. 2. 2 Extended striking techniques’ for the *toccato* articulation). Finally, the last variant of the rim shot is again notated similarly to a hit on a drumstick lying on the head. However, this time only the head of the beater is lying on the surface, which is depicted by the additional arrow. The player is then supposed to hit the shaft of the stick.

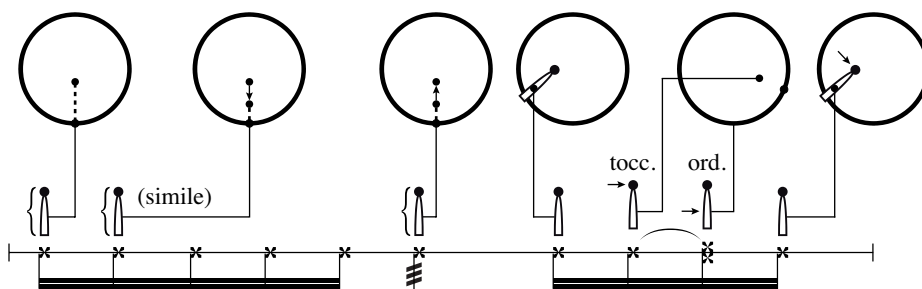

Fig. 209 Six rim shot variants.

4. 2. 4 Rubbing and bowing motions

Besides the normal and extended attacks, rubbing and bowing motions can be executed on percussion instruments. Rubbing motions can be performed on all membranophones and many idiophones, even the bars of mallet instruments or their resonators may be scraped in order to produce different sounds. They range from simple to very complex motions that may, in the case of the membranophones, involve the head and/or rim. Moreover, bowing motions are especially effective on certain idiophones, such as cymbals, tam-tams or the bars of mallet instruments. They are normally executed by means of a common bow, but, for instance, drumsticks or threaded wooden/metal rods can also be utilised.

4. 2. 4. 1 Previous methods of notation

Some composers do not specify which spot on the instrument is supposed to be rubbed, but merely request the player to perform a rubbing motion. For instance, Nono, in *Composizione per orchestra nr. 2*¹, makes use of two directions, rubbed [*strisciando*] and rubbed circularly [*strisciando circolarmente*]². Moreover, in *Con Luigi Dallapiccola*³ he depicts the action of scraping a plate bell (with a metal)⁴ by means of a symbol placed above the notation system:

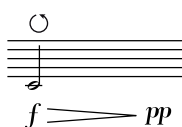

Fig. 210 Nono, *Dallapiccola*, p. 1 [reproduction of the score].

However, Eloy, in *Equivalences*⁵, utilises five different symbols in order to depict a rubbing – rapid semicircle [frotter – demi-cercle rapide], a rubbing – semicircle, slower after the half (or three-fourths of the circle) [frotter – demi-cercle plus lent en partant du centre (ou trois-quart de cercle)], a rotation in a very slow or extremely slow manner [tourner très lentement ou extrêmement lentement], an accelerated rotation [accélérer les tours] and a decelerated rotation [ralentir les tours]:

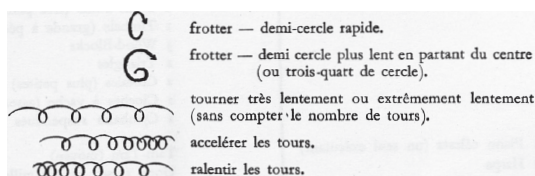

Fig. 211 Eloy, *Equivalences*, no page named [foreword].

¹ Luigi Nono: *Composizione per orchestra nr. 2*. Diario polacco '58. Mainz 1959.

² Cf. *ibid.*, p. 3.

³ Luigi Nono: *Con Luigi Dallapiccola*. For 6 percussion players and live-electronics. Milan 1979.

⁴ Cf. *ibid.*, p. 1.

⁵ Jean-Claude Eloy: *Equivalences*. For 18 instrumentalists. Paris 1965.

Further, in *Staub* Lachenmann differentiates between two rubbing motions, performed on the surface of percussion instruments. As can be seen in figure 212, he utilises a zigzag line as a note head in order to request a circular motion and a special note head to depict a back and forth scraping.

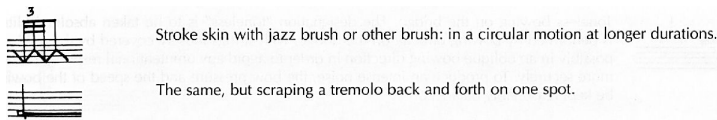

Fig. 212 Lachenmann, Staub, no page named [foreword].

In *NUN* Lachenmann also employs very complex scraping motions, executed with two drumsticks. The lower stick is always placed on the head and optionally makes circles on the skin whilst the upper stick scrapes the lower stick either in circles or from the shaft to the head. As can be seen in figure 213, Lachenmann depicts these actions by, firstly, presenting a drawing of the instrument and the two sticks, and, secondly, special note heads. Moreover, a fast *tremolo* action is notated by a wavy line and the shifting from the shaft [Schaft] to the tip [Spitze] by means of a common notation system with no clef, which represents the length of the beater.

Streichen mit gekreuzten Trommelstöcken auf Fell: unterer Trommelstock ruht bzw. kreist auf dem Fell, während der obere Trommelstock in lockerer Berührung auf dem unteren kreisend bewegt wird.



Pk., T. 126f.

Stroking with crossed drumsticks on drumskin: the lower drumstick rests on the skin or makes circles on the skin, while the upper drumstick, which is placed loosely on the bottom one, is moved in circles.

Timp., mm. 126f.

Scharren mit gekreuzten Trommelstöcken auf Fell: auszuführen in derselben beschriebenen Position, entspricht den oben beschriebenen Scharr-Aktionen auf Holzkannte. In diesem Fall wird der obere, scharrende Trommelstock auf dem unteren Trommelstock zwischen Schaft (dunkel) und Spitze (hell) bestimmt bzw. (bei Glissando-Aktionen) verlagert.



Pk., T. 201

Timp., m. 201

Fig. 213 Lachenmann, NUN, p. IX.

Further, Stockhausen, in *Mikrophonie I*¹, utilises a special notation system in order to depict scraping motions on the surface of a tam-tam. The x-axis of this system represents, as usual, the time and the y-axis the length of the instrument. This enables the depiction of up- and downward motions. The thicker the line, the higher the dynamic level. As can be seen in figure 214, transitions from low/high to high/low dynamic levels (*crescendi* and *decrescendi*) are also requested.

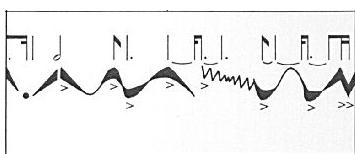

Fig. 214 Stockhausen, *Mikrophonie I*, Moment “TUTTI forte”.

Further, a complex motion on the head and rim is utilised by Lachenmann in *Accanto*. As can be seen in figure 215, he makes the percussionist stroke the rim and head (of a tom-tom) with a rough drumstick while he is supposed to simultaneously shift the point of contact from the tip to the shaft [mit rauhem Trommelstock gleich-zeitig über Fell und Rand streichen, dabei Berührstelle von der Spitze zum Schaft verlagern]. This direction is complemented by a note head, which depicts the motion from the tip to the shaft (also cf. figure 213).

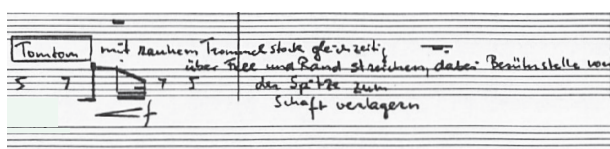

Fig. 215 Lachenmann, *Accanto*, p. 13.

¹ Karlheinz Stockhausen: *Mikrophonie I*. For tamtam, 2 microphones, 2 filters and controller. London 1964.

Moreover, Szalonek, in *Concertino*, requests rubbing motions on the rim by means of a special symbol, which is connected to the note head. As apparent from figure 216, he does not specify what kind of motion the player is supposed to perform.

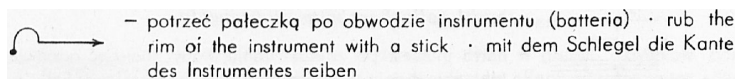

Fig. 216 Szalonek, *Concertino*, p. 4.

Further, Halffter, in *Fibonacci*, requests bowing motions by means of a symbol that replaces the note and the direction *con arco*. In the example presented in figure 217, the player is supposed to bow a suspended cymbal.

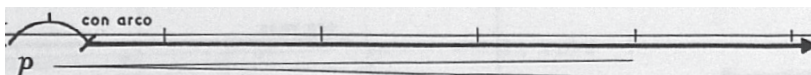

Fig. 217 Halffter, *Fibonacci*, p. 24.

Moreover, Lachenmann, in *Air*¹, requests the same action by means of a special note head and the direction *arco*:

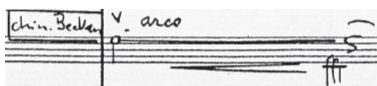

Fig. 218 Lachenmann, *Air*, p. 47.

4. 2. 4. 2 Discussion

In the case of requesting an unspecified rubbing motion, it is sufficient to – as Nono does – solely give the direction rubbed or *strisciando*. This method of notation is preferred here to utilising a more or less unrelated symbol (cf. figure 210) because it is simpler to request the rubbing motion by means of a distinct direction. For instance,

¹ Helmut Lachenmann: *Air*. Music for large orchestra and percussion-solo. Revised edition. Wiesbaden et al. 1994.

scraping motions on mallet instruments could especially be notated in this way because they are very limited. However, another method of notation needs to be introduced when more complex motions are supposed to be performed. This is because such motions could not be depicted in a simple manner by means of directions.

As the determination of the point of impact is closely related to the depiction of scraping motions, the method of notation introduced in section '4. 2. 3 The point of impact' may be transferred to the notation of complex rubbing motions. However, in such a case, the dot would have to be replaced by a distinct drawing, which displays the direction and extent of the motion. When compared to Eloy's symbolic method of depiction (cf. figure 211) or Lachenmann's method of notating each motion by means of a special note head (cf. figure 212), it may be stated that it is clearer and simpler to draw the motion on the surface of the instrument than to introduce a symbol or note head for any distinct motion. Further, the graphic depiction is capable of notating various complex motions in a simple manner whilst the two latter ones become more complex if further extended. This is because a distinct symbol or note head would have to be introduced for every distinct motion. As shown in the following section, it is also simpler to notate the complex motions with two drumsticks requested by Lachenmann (cf. figure 213), by means of a drawing than by special note heads and an extended notation system because a drawing contains a greater degree of instantaneous comprehension. Further, such a graphic depiction enables the notation of more complex motions than Stockhausen's method (cf. figure 214) because not only up- and downward motions may be depicted, but also – due to the additional axis – for instance, motions from the right to the left. Moreover, Lachenmann's method of requesting a shifting of the point of contact whilst rubbing on the head and rim (cf. figure 215) only contains a small degree of instantaneous comprehension. As in the case of the other

approaches, it would be simpler and clearer to depict the motion by means of drawing. Finally, Szalonek's approach towards the notation of rubbing the rim (cf. figure 216) can be only employed when an unspecified rubbing motion on the rim was supposed to be performed. Any further determination concerning the direction or extent of the motion could not be depicted by a symbol of this kind. Additionally, an unspecified rubbing motion could be requested in a clearer manner by giving a direction, such as *strisciando* (rim).

Furthermore, all bowing motions on percussion instruments resemble the action of bowing the body or other parts of string instruments (cf. section '2.5 Playing exceptional spots'). Therefore, the method of notation introduced in the chapter on string instruments may be transferred when concerned with the depiction of rubbing motions on the rim or bowing motions on idiophones. This method of notation also resembles the one introduced for the determination of the point of contact and is preferred to Halffter's approach (cf. figure 217) because it enables the depiction of any duration and is more exact with regard to the determination of the point of contact between the bow and instrument. Further, it is also clearer and simpler than Lachenmann's method of utilising a special note head and the direction *arco* (cf. figure 218). However, an unspecified bowing motion could be depicted by means of this direction and a common note head.

4.2.4.3 Suggestion for the notation of rubbing and bowing motions

Because the variation of the scraping motion on mallet instruments is limited, the method of depiction suggested here is to request it by means of the direction rubbed or *strisciando* and an optional *tremolo* symbol, which complements the pitch-based notation system (see below for an alternative method). This method could also be employed when an unspecified rubbing motion was supposed to be depicted on other percussion

instruments. Moreover, the direction *strisciando* (rim) can be used to request an unspecified rubbing motion on the rim and the direction *arco* to request an unspecified bowing motion.

However, more complex motions are displayed here in a graphic way. As can be seen in figure 219, singular motions are notated by means of a line complemented by an arrow, which is drawn onto the surface of a drum. In the example the percussionist is initially supposed to execute a semicircle rubbing motion for the duration of a dotted crotchet. This action is followed by a semicircle motion in the opposite direction. However, the speed of this motion is not constant. This is because two distinct notes are employed. The first one depicts the duration of the first half of the motion (a quaver) whilst the second one depicts the duration of the second half of the motion (a crotchet). As these motions are supposed to be connected, a *legato* slur is used.

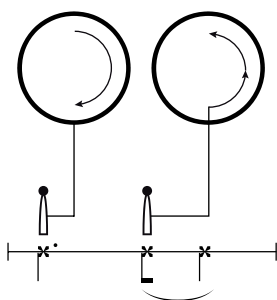

Fig. 219 Singular rubbing motions.

Moreover, an acceleration or deceleration of singular motions can also be requested by utilising additional agogic designations, such as *accelerando* or *ritardando*. However, it needs to be clearly outlined that these directions are not related to the overall tempo of the piece, but only the motion on the skin. Additionally, the motions could also be complemented by the direction *irregolare* in order to make the player execute these in an irregular manner. With regard to the dynamic level of rubbing motions, it needs to be noted that the tempo and dynamic level are partially related. This is because a very

low dynamic level may barely be achieved in combination with a very fast performance speed.

Further, repetitive motions are notated here by means of a line and a two-headed arrow. These kinds of motions are always complemented by a speed level designated as tempo, which is divided into six degrees. This index is necessary for the control of the performance speed because repetitive actions do – as opposed to singular actions – not have a fixed endpoint. Alternatively, more or less speed levels may be used. As apparent from figure 220, the percussionist is supposed to perform three repetitive actions whilst each one lasts for the duration of a semibreve. The first complex motion is executed with the minimum speed level 1/6, whereas during the second motion the speed level is increased from 2/6 to 5/6. The last articulation is similar to the action designated by Lachenmann as a *tremolo* back and forth (cf. figure 212). It is hence supposed to be performed virtually on a single spot. The speed level is now at its maximum.

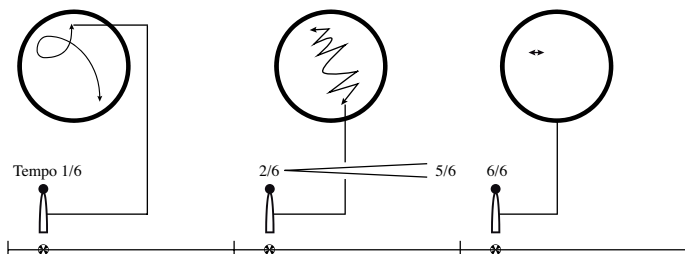

Fig. 220 Repetitive rubbing motions.

The starting point of the repetitive motion is determined by the line connecting the beater and the graphic depiction of the motion. When any other point than the ones where the direction of the motion is reversed is supposed to be determined as the starting point, an additional arrow – which determines the running direction of the initial motion – should be employed. This arrow needs to have a different shape in order to distinguish it from the other arrows. Further, the tempo index could be used as a

complementation of simple scraping motions on mallet instruments. Moreover, the arrow utilised to depict the *tremolo* motion – or an extended variant – could alternatively be employed for the notation of such a motion on mallet instruments when combined with a depiction of the instrument or single bars.

Further, the execution of singular or repetitive rubbing motions on the resonators of mallet instruments can be depicted by presenting a drawing of the instruments, including its resonators, in combination with a pitch-based notation system (because the pitch is slightly perceptible)¹. This method of notation is presented in figure 221 by taking the example of a vibraphone. The player is supposed here to initially perform a repetitive rubbing motion with tempo 4/6 on the resonator tube $f/F3$ for the duration of a minim. After a crotchet rest a singular *glissando*-motion from $a/A3$ to $a^2/A5$ is executed on the resonators. The sound production actually ends when the $a^2/A5$ is reached and the demisemiquaver hence applied pro forma. Further, strokes could be depicted by employing a dot instead of an arrow (cf. the previous section).

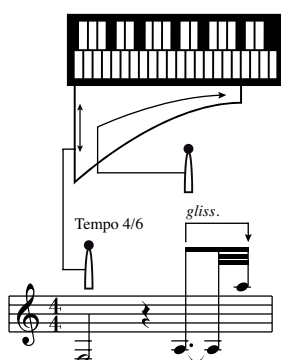

Fig. 221 Rubbing motions on the resonators of a vibraphone.

As mentioned, the *glissando* is in this work – in order to achieve a greater clearness and to enable the depiction of sliding motions that do not imply a gliding change of

¹ Cf. Sevsay, Handbuch, p. 168.

pitch – requested by means of an arrow and not in the traditional manner. Alternatively, the common method of depiction may be restored.

Furthermore, there are repetitive rubbing motions that do not involve a reversal of the running direction. They are referred to here as ‘circular’ motions. These kinds of articulations are also requested by means of two arrows. However, suchlike motions may also be singular. In such a case, only a single arrow is employed. Four examples are presented in figure 222. The first three ‘circular’ motions are repetitive. In the case of the last example, only one arrow is utilised. Hence a singular motion – which has the same starting point and endpoint – is requested.

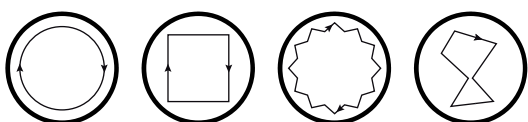

Fig. 222 ‘Circular’ rubbing motions.

Moreover, Lachenmann’s complex motions with two drumsticks (cf. figure 213) are presented in figure 223. In the example the player is supposed to perform three different articulations whilst each one lasts for the duration of a semibreve: 1. The tip of one drumstick is lying on the surface of the instrument and moved repetitively in circles. Simultaneously, the player uses another beater to execute a repetitive circular motion on the first stick. As apparent from the figure, the point of contact is the middle of the handle length. However, due to the character of the motion, it constantly varies and is, therefore, actually only depicted approximately. The described motion is supposed to be performed with tempo $1/6$. This tempo is also supposed to be applied to the motion of the first drumstick. In order to preserve a clear appearance of the score, the determination of a second speed index for this beater is dismissed. Thus both actions are here always performed with the same tempo. 2. The percussionist is supposed to perform a

repetitive scraping motion on a drumstick lying on the skin of the drum (the shaft is black and the arrow white in order to enable a clearer depiction). During this action the tempo is increased from 2/6 to 5/6. 3. The player is required to repetitively move a drumstick lying on the surface of the percussion instrument from the left to the right (while the initial running direction is not determined). Simultaneously, another beater is again used to execute a repetitive circular motion on the first stick. The speed level is now at its maximum.

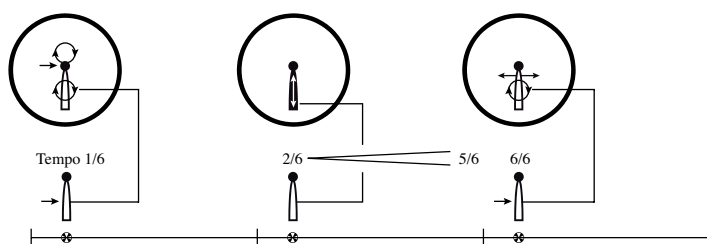

Fig. 223 Complex motions with two beaters.

Further, rubbing motions that involve the rim can be depicted in a similar manner as motions on the head. In the example presented in figure 224, three motions are executed. Each one again lasts for the duration of a semibreve. The first motion is performed with the entire length of the stick and (as a rim shot) simultaneously on the head and rim. Because the tip of the stick is during the motion moved away from the rim, the point of contact (between the stick and rim) is shifted from the head to the shaft (cf. figure 215). A dashed line is utilised here since there are only two points of contact (cf. figure 209). The second motion is a singular motion on the rim, executed with the middle of the handle. Subsequently, the percussionist is supposed to perform a repetitive circular motion on the rim. The speed level is 6/6. As is apparent from the example, scraping motions on the rim are also notated by means of a line and a single-/two-headed arrow while the line and arrow is white.

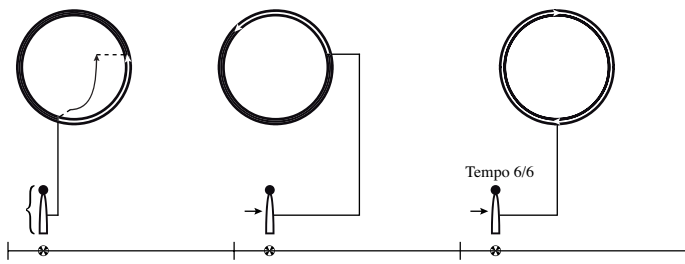

Fig. 224 Rubbing motions that involve the rim.

Further, the specified bowing of percussion instruments is requested by means of a symbol for the bow and an arrow, which determines the spot that is bowed. In the example the percussionist is supposed to bow the edge of a cymbal for the duration of a semibreve and then let it vibrate (*lasciar vibrare*). After a semibreve rest the player is required to bow the cymbal with a drumstick. As the stick is shorter, two note heads are utilised (whilst the player decides whether to perform an up- and down-bow or down- and up-bow motion).

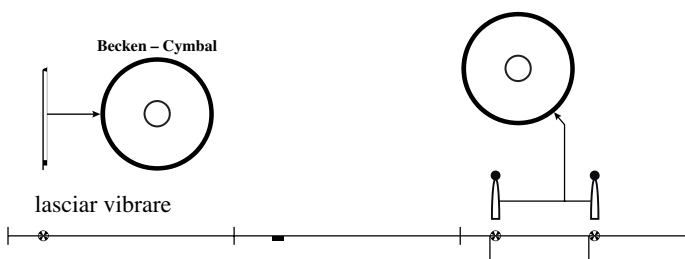

Fig. 225 Bowing percussion instruments.

Moreover, when percussion instruments are bowed, additional up- and down-bow symbols may be employed, the type of bow may be determined (e. g. contrabass bow), a so-called *glissando d'arco* may be performed (cf. section '2. 2. 2 The bow-*glissando*' and figure 67 in the chapter on string instruments) as well as conventional and unconventional bowing techniques may be requested. Further, when the bars of a mallet instrument, such as a vibraphone, are supposed to be bowed, it is sufficient to solely give the direction *arco* or *con/col arco* and depict the produced pitch. This is because

the point of contact between the bow and a single bar cannot be significantly varied (also cf. section ‘5. 4. 2 The utilisation of a bow and its notation’).

4. 2. 5 Articulations without agents of attack

On many percussion instruments sound may be produced without actually attacking these by means of beaters: cymbals may be swung in the air after the attack or smaller instruments be rubbed against each other. When previously prepared, it is – as shown below – also possible to produce sound, for example, on bongos by spinning or pushing these. Moreover, the percussionist is sometimes asked to drop items, such as rice or marbles, into or on percussion instruments.

4. 2. 5. 1 Previous methods of notation

Lachenmann, in *NUN*, requests to strike, and subsequently swing, a Chinese cymbal by means of squared note heads, a line derived from the notation of *glissandi*, accents in brackets and the additional direction swing rhythmically [rhythmisch schwenken]:

Chinesisches Becken, durch die Luft geschwenkt: Becken wird an der wulstigen Kuppe gepackt, in die Höhe gehalten und nach dem Schlag mit äußerst eckigen Bewegungen um das Handgelenk gedreht („geschwenkt“), sodaß eine Art ruckartig rythmisierte „Hall-Schwankung“ erzeugt wird.

Chinese cymbal swung in the air: the cymbals are grabbed by the bulge at the center, held in the air and, after they’ve been struck, are turned around the wrist (“swung”) with extremely angular motions so as to produce a kind of jerkily rhythmic “echo variation.”

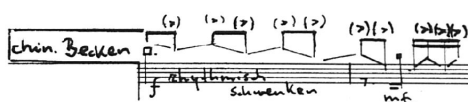

Fig. 226 Lachenmann, *NUN*, p. X.

Further, Kagel requests the player in *L'art bruit* to rub two sand blocks against each other by means of adding an arrow to the note tail and giving the direction rub slowly:



Fig. 227 Kagel, *Bruit*, p. 10a.

Moreover, in *Match* he requests the percussionist to hold two clash cymbals perpendicular to each other and turn these in opposite directions [beide Handbecken senkrecht aneinander halten und in entgegengesetzter Richtung drehen]. As can be seen in figure 228, Kagel presents a drawing, as well as an explanation, of the action and notates it by means of two note heads, arrows added to their note tails and circles above and below the notes.

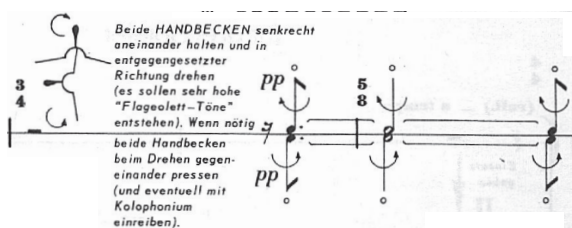

Fig. 228 Kagel, *Match*, p. 8.

Further, Stockhausen, in *Kontakte*, makes use of a prepared instrument. A concert bongo is in this piece turned upside down and filled “with a few beans that roll around on the membrane when the bongo is shaken (as in a rattle)”¹. The player is then either supposed to spin the bongo or to push it. The spinning action is – as apparent from figure 229 – depicted by a wavy line whilst the push is requested by means of a note head without note tail and an accent. Additionally, Stockhausen gives the additional direction spin slowly, push [langsam drehen, anstoßen] and utilises the additional agogic designation *accelerando*.

¹ Stockhausen, *Kontakte*, p. V.

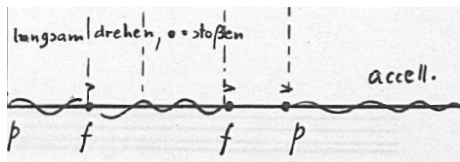

Fig. 229 Stockhausen, Kontakte, p. 5.

Finally, Kagel, in *L'art bruit*, makes a percussionist empty rice – which was previously filled into a dobachi¹ – into another dobachi. This action is, as apparent from figure 230, requested by means of a graphic depiction of the rice, which complements the common note, and an explanation.

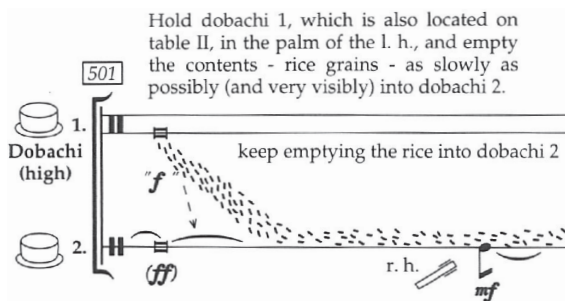

Fig. 230 Kagel, Bruit, p. 30a.

4. 2. 5. 2 Discussion

Because the articulations that are executed without agents of attack are uncommon and only rarely used, it is especially vital to depict these in the simplest and most comprehensible way. As shown in section ‘2. 8 Preparing the instrument and its notation’, the simplest method of notation makes use of a sketch that sufficiently explains the articulation or – according to the actions described in this section – preparation. Moreover, when the sketch is not clear enough, it may be complemented by an explanation.

Therefore, Lachenmann’s method of notating the swinging of cymbals by means of a line derived from the *glissando* notation (cf. figure 226) or circular stroking (cf. figure

¹ Japanese temple gong.

212) lacks simplicity. It would be more comprehensible to present a sketch of the action than to use a method of notation, which normally requests sliding/stroking motions. However, the direction he gives could be used as an additional explanation of the articulation. The same may be said about Kagel's approach towards the notation of rubbing two sand blocks against each other (cf. figure 227). Since it would also be simpler to request the articulation by means of a graphic depiction. Moreover, it might be, as mentioned, confusing to add a symbol to the note tail when semibreves are supposed to be depicted. In opposition, Kagel's notation of the spinning motion performed with two cymbals (cf. figure 228) is comprehensible and simple. However, in order to depict repetitive circular motions in a uniform manner, the arrow used to describe the character of the spinning motion (which is repetitive and circular) would have to be replaced by the method of notation presented in figure 222. Additionally, a speed level would have to be introduced as well as the note heads, arrows and circles be replaced with x-shaped notes.

Further, Stockhausen's method of notating the spinning motion or pushes (cf. figure 229) also lacks simplicity because the action is not depicted in a comprehensible manner. However, the directions he gives could be used as an additional explanation of a sketch, which depicts the action. By contrast, Kagel's approach towards the notation of emptying rice in an instrument (cf. figure 230), is simple and comprehensible. Instead of complementing the notes with a graphic depiction of the rice, a sketch of the action should be, however, rather used in order to gain an even higher degree of simplicity and instantaneous comprehension.

4. 2. 5. 3 Suggestion for the notation of articulations without agents of attack

All suggested methods of notation depict the action the percussionist is supposed to perform in a graphic way. In figure 231 two notation systems are utilised. The lower one (left hand) requests two hits on a Chinese cymbal and the system on top (right hand) depicts the swinging motion. After both hits it is required to let the cymbal further vibrate (*lasciar vibrare*). The first attack and the swinging action start simultaneously, whereas the second swinging action starts right after the strike. Moreover, in the case of the first swinging motion, the player is supposed to move his wrist in a quaver rhythm and in the case of the second motion, in a semiquaver rhythm (cf. figure 226). Since the action is repetitive, a single note and a speed level could be alternatively used in order to notate the swinging (cf. figure 220).

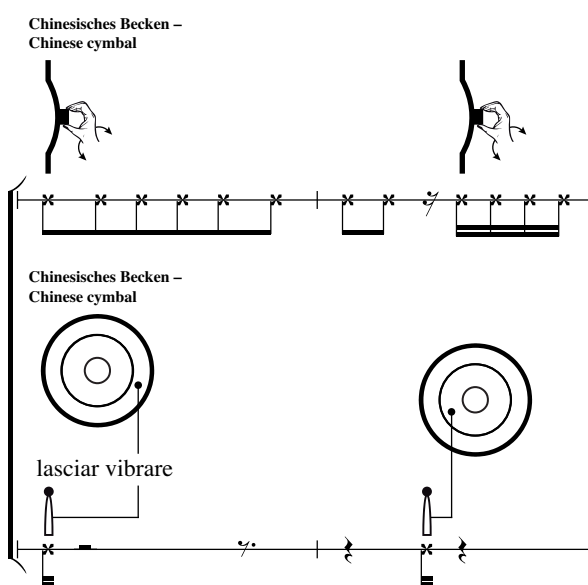

Fig. 231 Striking and swinging a Chinese cymbal.

Further, in figure 232 three special rubbing motions are depicted by taking the example of two Chinese cymbals:

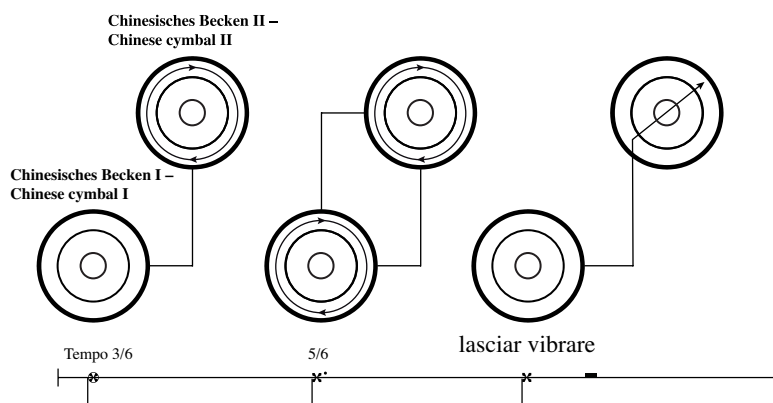

Fig. 232 Special rubbing motions.

In the case of the first action, the percussionist is virtually supposed to use Chinese cymbal I as a beater and perform a repetitive circular motion on Chinese cymbal II. This action is for the duration of a minim executed with the tempo $3/6$. Subsequently, the percussionist is required to repetitively rub both cymbals against each other (or in other words to execute a repetitive circular motion with cymbal I on cymbal II whilst performing a repetitive circular motion with cymbal II on cymbal I). This action lasts for the duration of a dotted crotchet and is performed with speed level $5/6$. Finally, the player is supposed to execute a singular rubbing motion with cymbal I on cymbal II and subsequently let them vibrate.

Further, in figure 233 the action requested by Kagel in *Match* is notated here in a similar manner as in figure 228. However, in this case, the arrows uniformly request the performance of a repetitive circular motion in opposite directions. Both motions are performed with the speed level $2/6$ and last for the duration of a semibreve. Only one notation system and note head is employed here for the right and left hand because their actions are (similarly to rubbing two cymbals against each other) connected. If one hand was supposed to stop spinning, a new sketch would have to be presented in order to show which of the two cymbals is spinning and which one is stopped.

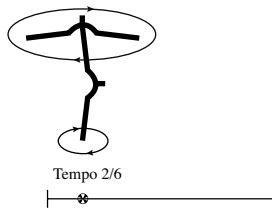

Fig. 233 Special circular motions.

The spinning motion of a concert bongo filled with beans (for the modification of percussion instruments cf. section ‘4. 5 Preparing the instrument and its notation’) may be depicted similarly. As can be seen in figure 234, the percussionist is initially supposed to repetitively turn the bongo clockwise with tempo $3/6$ for the duration of a minim, then execute a single push away from his body and go on with the spinning. This time the bongo is, however, spun counterclockwise with tempo $5/6$ for the duration of a dotted crotchet. Subsequently, the player is required to repetitively push the bongo back and forth with speed level $4/6$ for the duration of a quaver and finally perform repetitive pushes up and down with the same tempo for the duration of a dotted crotchet. In the case of the last pushes, the beans jump up and down on the skin and the percussionist might have to be advised to close the opening hole with the hand, with cardboard etc.

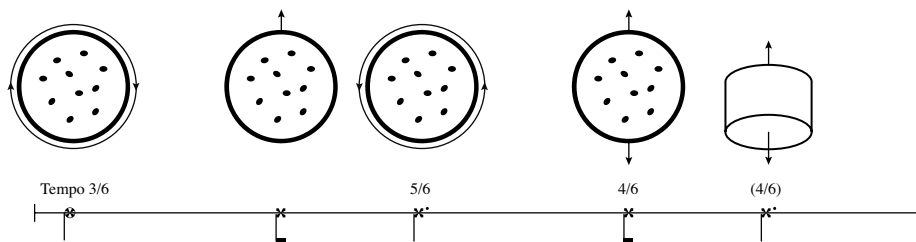

Fig. 234 Spinning and shaking a concert bongo.

Finally, the emptying of rice into an instrument or, for instance, letting a marble drop on the head of a timpano can be depicted by means of presenting a sketch of the action the player is supposed to perform. Such graphic depictions are presented in figure 235. Additionally, the distance between the dropped item(s) and the percussion instrument

may be determined (e. g. very high – high – medium height – low – very low or 3 m – 2 m – 1 m – 50 cm – 25 cm) and transitions between two heights be notated in the case of continuous actions, e. g. by connecting them by means of arrows.

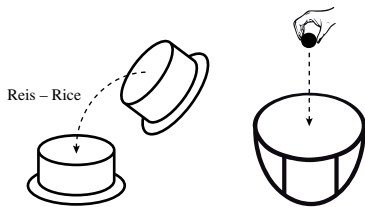

Fig. 235 Dropping items into/on instruments.

4. 2. 6 Playing the snares

When turned upside down, the snares of a drum may be played *alla chitarra* (guitar-style): they can be plucked (*pizzicato* – the snares only vibrate when playing with snares off), plucked vertically in order to make them rebound on the head (*Bartók pizzicato* – it can be executed when playing with snares on/off) and the snares be strummed (as in the case of the *pizzicato*, the snares only vibrate when playing with snares off). Further, the percussionist may also use his hand, as well as any kind of beater or item, to slide over the snares/over the head and snares simultaneously.

4. 2. 6. 1 Previous methods of notation

In ..., *den 24. xii. 1931* Kagel requests the percussionist to pluck the snares by means of a symbol resembling the one utilised for the depiction of the *Bartók pizzicato* and the direction pluck. Additionally, a zigzag line is employed to depict the subsequent vibration (the snare drum is played with snares off)¹:

¹ Cf. Kagel, 1931, p. 90.

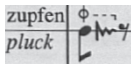

Fig. 236 Kagel, 1931, p. 91.

Moreover, Holliger, in *Pneuma*, requests a *Bartók pizzicato* by means of a squared note head and giving the direction lift a snare with the finger and make it rebound on the membrane [Schnarrsaite mit Finger heben und auf Membrane schnellen lassen]:

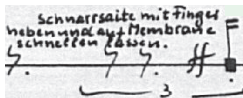

Fig. 237 Holliger, *Pneuma*, p. 37.

Further, in *L'art bruit* Kagel requests to strum the snares by means of the common *arpeggio* symbol and five 'transposed' notes. As apparent from figure 238, the snares are supposed to vibrate. Hence the articulation is executed with snares off.

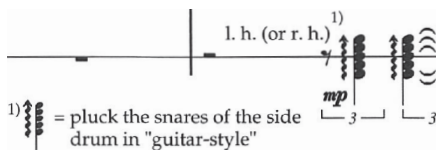

Fig. 238 Kagel, *Bruit*, p. 6a.

In the same piece he makes the percussionist also slide along the strings with his fingernails. As can be seen in figure 239, this action is depicted by means of five diamond-shaped and common note heads used in combination. In this case, a two lined notation system with drum clef is used. The upper line depicts the actions of the right hand whilst the lower line depicts the left hand's actions¹.

¹ Cf. Kagel, *Bruit*, p. 5a.

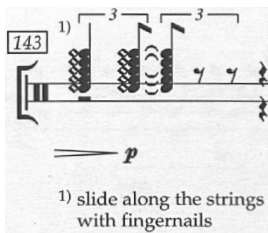

Fig. 239 Kagel, *Bruit*, p. 7a.

4. 2. 6. 2 Discussion

As most of the actions that may be performed on the snares are strongly related to conventional articulations of string or plucked instruments, they can be notated in the same way as the original articulations. By doing so, these sonic events are depicted in close relation to traditional notation as well as in a comprehensible and simple manner. However, this means that Kagel's method of notation for the *pizzicato* (cf. figure 236) as well as Holliger's approach towards the notation of the *Bartók pizzicato* (cf. figure 237) cannot be employed. Kagel depicts the normal plucking of the string in the way the *Bartók pizzicato* should be notated, although the direction *pizzicato* would adequately request it. Further, he makes use of a zigzag line to depict the subsequent vibration, which is traditionally depicted by the direction *lasciar vibrare* or simply by means of the duration. Moreover, Holliger makes use of a long direction in order to depict an event, which could in compliance with the requirements be simply depicted by means of the *Bartók pizzicato* symbol.

Furthermore, Kagel depicts the strumming of the snares by means of an *arpeggio* symbol (cf. figure 238). However, the action of strumming strings is – as shown in section '5. 4. 5 Strumming and its notation' – different from performing an *arpeggio*. Therefore, another method of notation needs to be employed in order to prevent the player from confusing the two articulations. Since the articulation is primarily a guitar technique, it is discussed below. As can be seen there, the action of strumming is depicted

ted by means of an arrow pointing up- (upbeat) or downwards (downbeat). Moreover, x-shaped note heads should be rather utilised than common and diamond-shaped ones because plucking the snares produces sounds with indefinite pitch. Further, with regard to the determination of how many strings are plucked, it needs to be noted that the number of snares may vary from instrument to instrument. Therefore, this parameter can be only depicted approximately. When compared, the introduction of a notation system with several lines that represent the strings of the snare drum is preferred to Kagel's method here. This is because such a notation system would depict the (single) snares in a clearer way. However, since the sound-wise difference between plucking one snare or another is small, and it is barely possible to pluck only one snare at a time, it is sufficient to utilise the notation system in order to depict a reduced number (as in Kagel's *L'art bruit*) instead of ten to fifteen snares (which is at most times the actual number of strings of a common snare drum).

Concerning the notation of sliding motions on the string, the traditional manner of notating these cannot be employed. This is because they are, on string instruments, notated by means of a pitch-based notation system and the common *glissando* notation, but on a snare drum the pitch-based system cannot be utilised in order to depict the position on the string. However, this action resembles the articulation designated as the *bow-glissando dietro il tasto* (cf. figure 20 and 21 in the chapter on string instruments) as well as the performance of a rubbing motion on the skin. When requesting solely motions on the snares, it is sufficient to use a similar system as the one employed for the *bow-glissando* behind the fingerboard because only motions up and down would have to be depicted. However, when more complex motions are required, the method of notation introduced for the rubbing motions would have to be utilised. In comparison to Kagel's approach towards the notation of a *glissando* on the snares (cf. figure 239),

these two methods are more exact since they permit the notation of various different motions, whereas Kagel's method is only able to depict a single kind of motion.

4.2.6.3 Suggestion for the notation of playing the snares

As apparent from figure 240, a common notation system with no clef is employed here to depict any of the conventional articulations executed on the snares. The system depicts the extent of the strings while any of the line represents, as far as possible, a single snare in the case of the *pizzicato*, or shows if 1/5, 2/5, 3/5, 4/5 or all strings are strummed. Moreover, it may be defined if the lowest line/highest line represents the left/right outer string (from the player's perspective). In the example the percussionist is supposed to always let the strings vibrate (*sempre lasciar vibrare*). Initially, he is required to play a sequence of six semiquaver *pizzicati*, starting and ending with the same outer string. These actions are performed *senza corde* (with snares off). After a crotchet rest two *Bartók pizzicati* are executed *con corde* (with snares on). The first *pizzicato* is executed on the middle snares and the second one on the outermost snares. After another crotchet rest the strings are strummed. The first strumming (upbeat) involves all strings, whereas the second one (downbeat) is only executed on 3/5 of the strings. Further, the two actions designated as *senza* and *con corde* could be notated as distinct sonic events by utilising (five) notes in combination with the respective direction. Generally, the dynamic level is always low when playing on the snares – except for when performing *Bartók pizzicati*.

sempre lasciar vibrare
 senza corde con corde senza corde
 pizz.

Fig. 240 Playing on the snares.

When requesting rubbing or sliding motions that involve the snares, the notation system changes. As apparent from figure 241, two different methods can be used to depict these motions. The first variant consists of two components, a traditional timeline and a representation of the length of the snares whilst the arrows depict what kind of motion the player is supposed to perform. They are related to the duration, determined by the notes. In the example a brush is used¹, and the snares are on. An arrow pointing upwards requests that the beater is moved away from the body and an arrow pointing downwards that the motion is executed in the direction of the player's body. The first two singular crotchet motions are executed *sulle corde* (on the strings) while the third repetitive crotchet motion and the final singular semiquaver motion are executed *sulle corde e sulla pelle* (on the strings and the head). The *legato* slur is used to depict that the first three motions are connected. Further, when a more complex motion on the head and the snares is supposed to be performed, another method of notation needs to be employed. In the second example the player executes a singular motion with a brush for the duration of a semibreve. During this motion the strings are crossed two times.

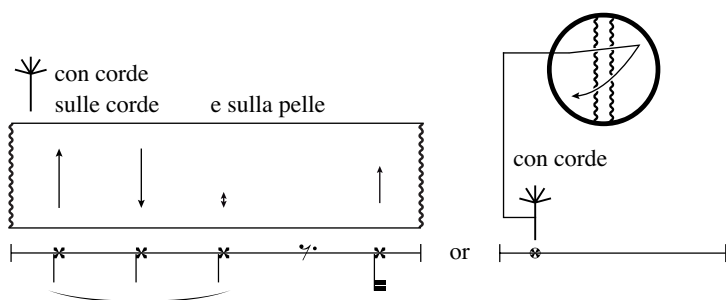

Fig. 241 Motions on the snares and head.

¹ Cf. Sevsay, Handbuch, p. 215.

4.3 'Pitch' bending – the extended *glissando*

As mentioned in the chapter on wind instruments, the term pitch bending or bend tone describes a special *glissando* technique. On membranophones the 'pitch' may be raised by controlled hand or elbow pressure on the drum head¹ whilst on gongs and tam-tams the same effect is created by lowering these instruments after or during the attack into a tub of water, – which lowers their 'pitch' – or removing them from the water tub – which raises their 'pitch'^{2/3}. In the case of the vibraphone, the pitch may be bent by placing a mallet on the nodal point of a bar after the attack and sliding towards the middle. This produces a decrease in pitch.

4.3.1 Previous methods of notation

Stone suggests notating the 'pitch' bending technique on membranophones by means of note heads placed in between two lines, indicating whether the attack produces a low or high sound:



Fig. 242 Stone, Notation, p. 223.

Moreover, Cage – the discoverer of the water gong effect – depicts in *First construction (in metal)*⁴ the pitch bending articulation by means of an arrow pointing downwards or upwards and the direction lower (gong into water) or raise. As apparent

¹ Cf. Stone, Notation, p. 223.

² Cf. Sevsay, Handbuch, p. 162.

³ As mentioned, most membranophones and all tam-tams have an indefinite pitch.

⁴ John Cage: *First construction (in metal)*. Percussion sextet with assistant. New York 1962.

from figure 243, the percussionist is supposed to play rolls whilst lowering or raising the instrument.

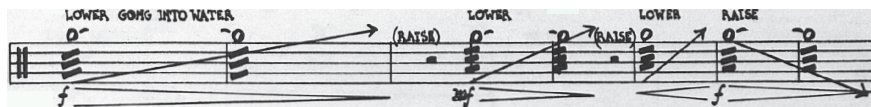

Fig. 243 Cage, First construction, p. 5.

Further, in *Mundus canis* (“A dog’s world”)¹ Crumb requests the percussionist to lower a tam-tam into a water tub by means of ‘transposed’ notes and the common *glissando* notation. Three different ‘itches’ are employed. The highest note requests the player to hold the tam-tam above water, the middle note (on the line) depicts that the tam-tam is half-submerged and the lowest note that the tam-tam is fully submerged. Simultaneous to the ‘pitch’ bending, the percussionist is supposed to play a roll, which is (wrongly) depicted by means of the trill symbol²:

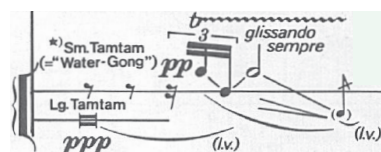

Fig. 244 Crumb, *Mundus*, p. 8.

4. 3. 2 Discussion

In section ‘3. 4 Pitch bending – the extended *glissando*’ a method of notation for the pitch bending technique that complies with the postulated criteria has been presented. This method may be transferred to percussion instruments in order to depict the ‘pitch’ bending on percussion instruments with definite and even indefinite pitch. When doing so, the technique is depicted in a uniform way. The method resembles Stone’s approach

¹ George Crumb: *Mundus canis* (“A dog’s world”). Guitar and percussion. New York et al. 2000.

² Cf. Sevsay, *Handbuch*, p. 207.

towards the notation of the ‘pitch’ bending on membranophones (cf. figure 242). However, the pitch bending system for wind instruments complements the normal notation system, whereas Stone’s system replaces it. Since it is necessary to have two systems in the case of wind instruments (one that depicts the fingered tone and one that presents the transposition in time), the method of notation for the ‘pitch’ bending on membranophones should also consist of two systems (one that depicts the attack and one that depicts the ‘transposition’ in time). The introduction of a distinct timeline for the ‘transposition’ would, in the case of percussion instruments, also enable notating the sound production and its transformation independently from each other.

With regard to Cage’s method of notation (cf. figure 243), it may be additionally said that it is inexact because only one bending level – no pitch bending (instrument above the water) plus the maximum pitch bending (fully submerged) – as well as the transition from one to the other level (lower and raise) may be depicted. Further, his approach is confusing because he requests the lowering by means of an arrow pointing upwards (despite the pitch being lowered) and vice versa. Further, Crumb’s method (cf. figure 244) may be described as a variation of Stone’s approach. It permits the notation of two bending levels – no pitch bending (instrument above water) plus the medium pitch bending (half-submerged) and the maximum pitch bending (fully submerged). Although the method could be further extended in order to depict more than two levels, it is – as mentioned – preferred to notate the articulation by means of a distinct system.

4.3.3 Suggestion for the notation of ‘pitch’ bending

The suggested method of notation hence makes use of an additional notation system, referred to as the ‘transposition’ system. The x-axis of the ‘transposition’ system represents, as usual, the duration and the y-axis the degree of the ‘transposition’. More-

over, the white dots (◊) depict the degree of the ‘transposition’ in time. In figure 245 the ‘pitch’ of a membranophone is bent. There are four levels for upward ‘transpositions’ whilst the lowest axis (0) depicts the unbent sound. In the example the percussionist is supposed to perform a (one-handed) roll on the head of a membranophone and constantly shift the point of impact for the duration of a semibreve (cf. section ‘4. 2. 3 The point of impact’). Simultaneously, the player is required to use the other hand or elbow to raise the ‘pitch’ of the instrument. Initially, it is raised to level 3/4 for the duration of a crotchet, then lowered to the original unbent sound for the duration of a minim and finally raised to level 1/4 for the duration of a crotchet.

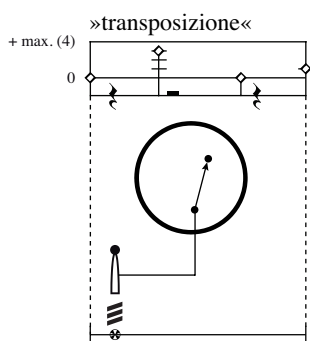

Fig. 245 ‘Pitch’ bending and shifting the point of impact.

Alternatively, more or less than four levels may be employed. Further, the reversed transposition system (e. g. from 0 to –4) may be utilised for the notation of the water gong effect and the pitch bending on the vibraphone. However, in the case of the gong and vibraphone, the lower system depicts the pitch, the indication *transposizione* hence does not need to be put in quotation marks and two dots could – in the case of the vibraphone – be used in order to depict a simultaneous pitch bending on two bars. Moreover, it needs to be noted that the further the tam-tam or gong is lowered, the higher the point of impact needs to be.

4.4 Muting

This section focuses on the **application of mutes** as well as the **hand muffling**. Moreover, because they may be described as extended muting techniques, the **stop attack** and the **wah-wah effect** on percussion instruments are also discussed.

4.4.1 The application of mutes and its notation

The application of mutes depends on the instrument that is supposed to be muffled. For instance, tam-tams may be muted by placing these on cloth or holding the instrument between the knees. Moreover, membranophones may be muted by placing cloth or other items on the head. The application of mutes has been extensively discussed in section '3.8.1 The application of mutes' by taking the examples of wind instruments and can be regarded as nearly conventional. Therefore, another discussion of this topic is dismissed here. When willing to employ mutes on percussion instruments, the paradigm pre-sented in the chapter on wind instruments may be transferred to percussion instruments. Hence the application of mutes is suggested here being notated by means of the direc-tion with/without mute or *con/senza sordino* whilst the description of the mute – e. g. on cloth, between knees or cloth – may be given in brackets. Further, in the case of playing on the snares, the plucking of muted strings (*senza corde*) is very ineffective and, there-fore, not discussed here. A variant would be to pluck the snares *con corde* (cf. section '4.2.6 Playing the snares').

4.4.2 Hand muffling and its notation

Hand muffling is discussed in its own section because this muting technique may be used in a more complex way than the techniques described in the previous section. The

instrument may be either muted prior to/simultaneous with or subsequent to the attack. When employed in the same way as the other mutes and hence slightly prior to/simultaneous with the attack, hand muffling may be notated by means of the direction with/without mute (hand) or *con/senza sordino (mano)*. However, when requested subsequent to the attack, the muting is often depicted by means of a diamond-shaped note head or a muting sign¹. The latter variant is, for instance, employed by Lachenmann in *NUN*. As apparent from figure 246, the muting sign is used in order to clearly outline that the instrument is muted at a given moment.

Dämpfzeichen: Angeschlagenen Klang präzise zum angezeigten Zeitpunkt weg dämpfen.

Mute signs: mute the sound precisely at the given moment.



Fig. 246 Lachenmann, *NUN*, p. VII.

Further, some composers employ x-shaped note heads instead of diamond-shaped ones. For instance, Foss, in *Echoi*, makes use of this method. In the example presented in figure 247, a vibraphone player is supposed to mute one bar after another.

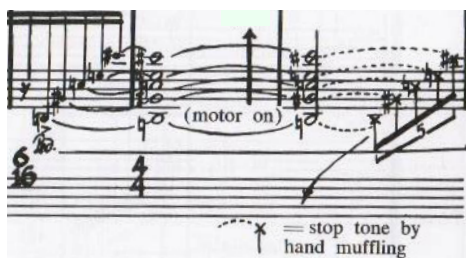

Fig. 247 Foss, *Echoi*, p. 18.

However, it needs to be noted that there is not always a necessity to specifically outline that an instrument is muted, but this information may be, in some cases, regarded as redundant. This is because the duration of the subsequent vibration can be sufficiently depicted by the note's duration when playing *non lasciar vibrare*. For instance,

¹ *Ibid.*, p. 208.

when the player is supposed to hit a cymbal with a high dynamic level and the sound that is produced has the duration of a crotchet, the cymbal needs to be muted after a crotchet because otherwise the sound would last longer than depicted. The depiction of the muting could, however, become necessary when previously giving the direction *sempre lasciar vibrare*. This is because, in such a case, only the duration of the attack needs to be depicted, and all sounds last as long as they naturally last when not muted. If one would, however, want one of the sounds to last shorter, either the direction *non lasciar vibrare* needs to be utilised, the duration of the sound be notated and subsequently the direction *sempre lasciar vibrare* again be employed or simply the muting be specifically requested once by means of a sign or special note head.

With regard to the approaches towards the notation of the muting, it may be said that diamond-shaped note heads are normally employed for the notation of harmonics. They are also used for the depiction of muting stops on string and plucked instruments because the pressure that is applied to the string is similar to when fingering harmonics. In both cases, the notes are used to determine the fingering (cf. section '2. 6. 2 Exact muting stops and their notation'). However, on percussion instruments no fingerings are employed, but only the point of impact may be determined. Moreover, in the case of hand muffling, it is not necessary to determine the point of impact. Therefore, it would be confusing to employ diamond-shaped note heads in order to request the muting of a percussion instrument. Further, x-shaped note heads cannot be used for the depiction of the hand muffling because they are, in this work, constantly employed to notate sounds with indefinite pitch and could hence not be used in order to depict the muting of these instruments. Therefore, it is preferred to request the muting by means of the muting sign.

In figure 248 the player is supposed to let the instrument vibrate. Hence all produced sounds either linger on until they naturally decay or need to be muted. Initially, the player strikes the tones $f^1/F4$ and $a^1/A4$. These bars are muted after they have vibrated for the duration of a crotchet (in total). In this case, only the muting sign needs to be employed because it distinctly requests that the whole instrument is muted simultaneously. After a crotchet rest, the instrument is struck again. However, this time a chord is played and each bar muted at a different point in time. Each of the produced tones lasts here a semiquaver longer than the adjacent lower tone. In order to notate this, the muting sign is used in combination with a depiction of the bar that is supposed to be muted. It needs to be noted here that the action of muffling an instrument is different from touching a vibrating instrument with a beater or item. This is because this articulation is utilised to produce the sizzle effect and the instrument is hence not muted, but played (cf. section ‘4. 2. 2 Extended striking techniques’ for the notation of this technique).

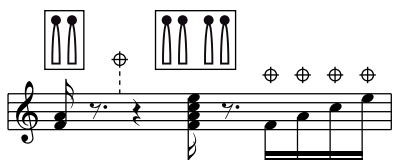

Fig. 248 Hand muffling (*lasciar vibrare*).

When playing *non lasciar vibrare*, the muting can be notated by means of the note's duration. As apparent from figure 249, each of the tones produced by the percussionist lasts again a semiquaver longer than the adjacent lower tone. This is depicted by simply determining each tone's duration.

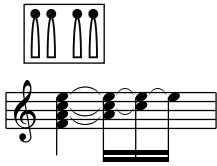

Fig. 249 Hand muffling (*non lasciar vibrare*).

4.4.3 The stop attack and its notation

Another special muting articulation, referred to as the stop attack or dead stroke, is often performed on percussion instruments. When requested, the beater does not bounce back, but remains firmly in contact with the surface after the attack¹. Hence the instrument is attacked and simultaneously muted. The result is that the instrument vibrates shorter than it would if the beater was released after the attack. Stop attacks are often used. For example, Lachenmann employs this articulation in *NUN*. He requests dead strokes by means of *staccato* dots:

Notenköpfe mit Staccato-Punkten bedeuten Stop-Schläge.

Note heads with staccato dots signify stop attacks.

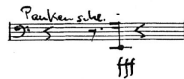

Fig. 250 Lachenmann, *NUN*, p. VII.

However, because the stop attack is, as mentioned, a stroke that involves a simultaneous muting with the beater itself, the method of notation should take this into account. Further, concerning Lachenmann's method it may be additionally said that it could be employed in the case of playing on most membranophones. But on instruments that vibrate longer than these, a *staccato* can also be produced by muting the instrument with the hand before the next attack. Thus the utilisation of the *staccato* dot could become ambiguous.

¹ Cf. *ibid.*, p. 209.

Therefore, the suggested method of notation requests this articulation by means of the beater symbol – which depicts the normal attack – and a muting sign in combination. In figure 251 the bars of a mallet instrument are attacked in this way. Initially, the player executes a dead stroke on the *f/F3*. After a crotchet rest four beaters are used simultaneously. The sticks in the left hand execute a dead stroke and the sticks in the right hand a normal attack. Hence the beaters only remain firmly on the bars *f/F3* and *a/A3*. When this sequence is played *lasciar vibrare*, the other tones linger on after the stop attack and when playing *non lasciar vibrare*, all bars are additionally muted with the hand after the duration of a semiquaver (cf. the previous section).

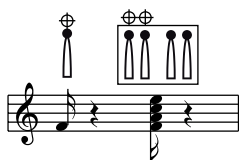

Fig. 251 The stop attack.

4. 4. 4 The wah-wah effect and its notation

The wah-wah effect can on small percussion instruments, such as sleigh bells or maracas, be produced by slowly opening and closing the hand while shaking these repetitively. Moreover, a kind of wah-wah effect also occurs when gradually opening or closing two hi-hat cymbals. For instance, Kagel, in *Fürst Igor*, *Strawinsky*¹, requests a wah-wah effect on sleigh bells by means of a diamond-shaped note head (which depicts the muting) and the direction *wow-wow-effect*². Moreover, the player is supposed to execute a roll and hence repetitively shake the bells:

¹ Mauricio Kagel: *Fürst Igor*, Strawinsky. For bass voice and instruments. Frankfurt/M. et al. 1988.

² The wah-wah effect is, in this work, wrongly referred to as the *Wau-wau-Effekt* or *wow-wow-effect*.

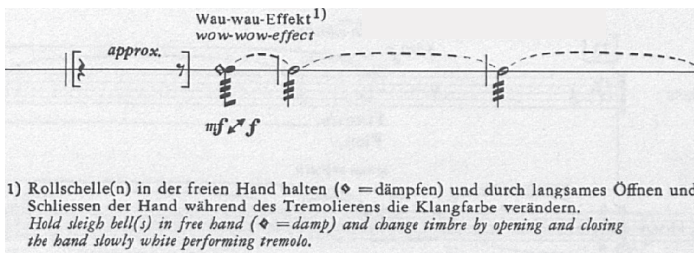

Fig. 252 Kagel, Fürst, p. 11.

Moreover, Stone suggests utilising an additional notation system placed above the original system in order to depict the gradual opening and closing of a hi-hat. The x-axis of this system depicts, as usual, the time and the y-axis the degree of opening. No distinct timeline is, however, introduced for this system, but the y-axis of the additional system related to the lower notation system. As can be seen in figure 253, either a graphic depiction of the open and closed hi-hat or the symbols ‘o’ (open) and ‘+’ (closed) are employed.

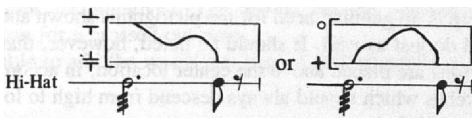

Fig. 253 Stone, Notation, p. 223.

The notation of the wah-wah effect has been extensively discussed in section ‘3. 8. 2 The wah-wah effect’. As mentioned there, the two symbols ‘o’ and ‘+’ are conventionally employed for the notation of the wah-wah effect while in the suggested method of notation these symbols are used as note heads to exactly notate the transitions between these two states. In order to request the effect in a uniform way, this method needs to be transferred to percussion instrument. Moreover, this approach towards the notation of the wah-wah effect may be described as more exact than the method suggested by Kagel. This is because the actual performance of the effect is in *Fürst Igor, Strawinsky* at the player’s discretion. Concerning Stone’s method of notation, it may be

additionally said that the introduction of a distinct timeline for the effect is preferred here. This is because depicting the wah-wah effect in relation to the original system complicates notating the sound production and the effect independently from each other. However, Stone’s approach admittedly enables (similarly to the ‘transposition’ system displayed in figure 245) the depiction of different opening degrees. Hence when willing to request more than two states (e. g. an open, half-closed and closed hi-hat), the method of notation suggested in the chapter on wind instruments needs to be further extended.

Therefore, it is suggested here notating the wah-wah effect by means of the symbols ‘o’ and ‘+’ whilst the duration of the transition between these two states is depicted by using the symbols as note heads. Moreover, an additional state ‘(+)’ (half-closed) is introduced for the hi-hat. Articulation symbols, such as *legato* slurs or *staccato* dots, can additionally be used to determine the character of the transitions. In the example presented in figure 254, a percussionist is supposed to play a semibreve roll on a hi-hat. The transitions between opening and closing may be described as follows: open to closed (quaver – *legato*), to half-closed (semiquaver – *staccato*), to open (quaver – normal articulation), to open, closed, open (quavers – *legato*), to half-closed (quaver – normal articulation), to closed, open and half-closed (semiquavers – *staccato*). In the same way – but without the additional state ‘(+)’ – can the wah-wah effect on small percussion instruments be notated.

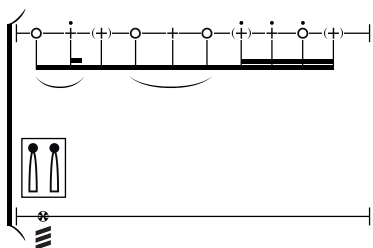

Fig. 254 The wah-wah effect on a hi-hat.

As mentioned in the chapter on wind instruments, an alternative method of notation would be to employ the two to three states as dots in a single lined ‘transposition’ system (cf. figure 245) because notes suggest that sound is produced and the original sound is, in this case, actually transformed.

4.5 Preparing the instrument and its notation

There are various examples of preparations: for instance, Stockhausen, in *Kontakte*, requests the percussionist to fill a bongo with beans. Moreover, he makes in the same piece use of three tom-toms with plywood glued on in place of the membrane¹. Further, Kagel, in *Anagrama*, requests to fix three castanets to a board² or Lachenmann, in *NUN*, to attach a bongo drum to a timpano³. As in the case of string and wind instruments, there are numerous ways of preparing percussion instruments. Similarly, it is also, on the one hand, barely possible to list them all and subsequently develop a coherent method of depiction whilst, on the other hand, it is also not necessary to do so since most preparations are executed previously to a performance and may be simply described in the foreword to a work. Further, when preparations are supposed to be executed during a performance, they are suggested here always being notated by means of a sketch. This is because it is the simplest way of depicting these. When the sketch is not clear enough, it may be complemented by an explanation (cf. sections ‘2. 8 Preparing the instrument and its notation’ and ‘3. 6. 2 Constructional modifications and their notation’). Nevertheless, preparations may lead to the introduction of new playing techniques that should then be notated in accordance with all other techniques presented in this work.

¹ Cf. Stockhausen, *Kontakte*, pp. III and V.

² Cf. Kagel, *Anagrama*, no page named [foreword].

³ Cf. Lachenmann, *NUN*, p. IX.

4.6 Summary

In this part of the work the unconventional playing techniques of percussion instruments are introduced, their previous methods of notation discussed and suggestions for their notation presented. The first section focuses on the extension of the percussive apparatus, which implies the introduction of special agents of attack as well as special percussion instruments. The next section is then devoted to extended modes of attack. One of them is referred to as the extended utilisation of the agents of attack. The agents of attack are used in an augmented manner when a strike is executed with the handle of the beater, the entire length of a stick is utilised, one of the ends of the beater touches an instrument at right angles as well as when the agent's point of contact differs from the normal one or is shifted during the execution of several strokes. Further, the extended striking techniques are related to the bowing techniques *saltando*, *balzando*, *toccato* and *gettato*. Another extended mode of attack is the augmented determination of the point of impact on the instrument. For instance, the middle or edge of the head, as well as the rim or shell of membranophones, may be hit. Additionally, the point of impact may also be shifted and items or beaters lying on the instrument may be struck. Moreover, rubbing and bowing motions may also be executed on percussion instruments. When requesting rubbing motions, the player is supposed to scrape the head, shell, rim or even the resonators of mallet instruments while bowing motions are preferably executed on idiophones. There are further articulations without agents of attack. For example, cymbals may be swung in the air after the attack, instruments be rubbed against each other or the player be requested to drop items on percussion instruments. Finally, a special extended mode of attack is to play the snares *alla chitarra*. As the strings of plucked or string instruments, snares may be plucked or strummed. The player may also use any kind of beater to slide over them.

The extended *glissando* technique is, as in the case of wind instruments, the ‘pitch’ bending. On membranophones (with indefinite pitch) the ‘pitch’ may be raised by controlled hand or elbow pressure whilst, for instance, gongs (with definite pitch) may be lowered into a tub of water after the attack in order to lower their pitch or vice versa. In the case of the vibraphone, the pitch may be bent by placing a mallet on the nodal point of a bar after the attack and sliding towards the middle. Further, there are four extended muting techniques on percussion instruments. One is to constantly apply mutes, e. g. placing cloth on the head or holding the instrument between the knees. Another is referred to as hand muffling subsequent to the attack. The stop attack or dead stroke is the third muting technique. When requested, the beater does not bounce back, but remains firmly in contact with the surface after the attack. Finally, the wah-wah effect can on small percussion instruments, such as sleigh bells or maracas, be produced by slowly opening and closing the hand and, for instance, also occurs when gradually opening or closing two hi-hat cymbals. Further, the final section focuses on the preparation of percussion instruments and portrays some of the preparations that may result in new playing techniques being created.

5. THE TECHNIQUES OF PLUCKED INSTRUMENTS

There are two big groups of plucked instruments, plucked chordophones and plucked idiophones. When producing sound on chordophones, strings are plucked whilst, in the case of idiophones (e. g. jew's harps, kalimbas, marimbulas), an elastic body is plucked. The chapter on plucked instruments, however, only discusses the extended playing techniques of the two most important plucked chordophones, the harp and the guitar. This is because plucked idiophones are only rarely used in Western art music and comprise only a very limited number of unconventional extended playing techniques¹. Moreover, the notation of these techniques may be easily derived from the methods of notation presented in the previous chapters (for instance, because on the kalimba the wah-wah effect may be produced, the paradigm presented in section '3. 8. 2 The wah-wah effect' or '4. 4. 4 The wah-wah effect and its notation' may be employed when utilising this instrument). Further, electric guitars and basses, as well as the effects that may be utilised to modulate or transform the sound of electric instruments, are not specifically discussed in this chapter. These instruments and effects could be subject to a work that focuses on the notation of extended techniques of electric instruments and/or electroacoustic techniques (cf. the conclusion).

Despite the harp and guitar being heterogeneous instruments, many extended playing techniques may be produced on both instruments in the same manner. Therefore, this chapter is not divided into two parts, but solely grouped by unconventional extended playing techniques. In the beginning of each section it is indicated if a special technique may only be produced on one of these instruments. Moreover, all techniques of the guitar may be employed on steel-string acoustic guitars and classical guitars. When an unconventional extended playing technique of string instruments may also be employed

¹ Cf. Sevsay, Handbuch, pp. 187 and 217.

on plucked instruments, another discussion of this technique is dismissed in the following sections and merely the suggested method of notation presented.

With regard to plucked instruments, the notation of the *vibrato* (guitar) and trill, stops, clusters (cf. section ‘6. 6. 1 Clusters’), the basic *pizzicato*, the *Bartók pizzicato* (guitar), the basic *glissando* (playing adjacent strings in a fast manner, in the case of the harp, and sliding on the fretboard in the case of the guitar), the common modes of attack, the production of harmonics and the *scordatura* (previous to, or simultaneous with, playing and including the utilisation of a capo tasto) are regarded here as conventional¹. Their notation can be accessed through the essential handbooks on instrumentation whilst most composers use the method of depiction that can be found there.

Whereas, the main unconventional elements of sound production presented in this chapter are extended *pizzicato*, *tremolo* and trill techniques, common and extended playing positions on the string, extended *glissando* techniques, extended modes of attack, playing exceptional spots, muting, extended stopping techniques, percussive effects and preparing the instrument. Concerning the dynamic level of these articulations, indications are – as far as possible – presented when the execution of the action is, in terms of the loudness, limited. Microtones on the guitar can be produced by means of microtonal *vibrati* or the *scordatura*. Another variant is the bending technique, which is discussed in section ‘5. 3. 2 The pitch bending technique and its notation’. In the case of the harp, microtones may be created by means of the *scordatura* or adjusting the pedal in between two positions². The latter variant is discussed in section ‘5. 3. 6 The pedal-*glissando*’.

¹ Cf. *ibid.*, pp. 217-248.

² Cf. *ibid.*, pp. 241f. and 247f.

5. 1 Extended *pizzicato*, *tremolo* and trill techniques and their notation

In the case of the guitar, the direction *pizzicato* normally requests to mute the strings while the direction *pizzicato effleuré* requires the player to touch the string lightly with the left hand¹. However, this method of notation is opposed to the conventional method of depiction for the *pizzicato* and the muting on all other instruments as well as the notation of the extended playing technique discussed in section '2. 6. 2 Exact muting stops and their notation'. As the traditional utilisation of these directions causes a great deal of confusion, they are dismissed here. However, when handling these directions in this way, it is absolutely necessary to explain the violation of the convention when the direction *pizzicato* or exact muting stops first occurs in a musical work. Alternatively, the conventional method of depiction for the muting may be employed only on the guitar, the normal plucking of the string be requested by the direction *modo ordinario* and the direction *pizzicato effleuré* be complemented by the method used for the depiction of exact muting stops (cf. section '5. 7. 1 Exact muting stops and their notation').

Further, all extended *pizzicato* techniques discussed in section '2. 1 Extended *pizzicato* techniques and their notation' may be transferred to either the harp or the guitar: the ***pizzicato with the left hand*** needs to, however, only be specifically requested in the case of the guitar because the utilisation of the left hand is depicted on the harp by means of the two notation systems. As shown, the execution of the left-hand *pizzicato* on string instruments can be requested by means of the direction *pizzicato (mano sinistra)*. This method of notation is, therefore, also suggested for the guitar. Further, the fingernail *pizzicato* is normally depicted by means of an additional fingernail symbol whilst the utilisation of a pick instead of the fingers is, in most cases, requested by employing a drawing of the plectrum and giving the direction *pizzicato* (cf. figures 4

¹ Ibid., p. 247.

and 5 in the chapter on string instruments). Therefore, it is also suggested notating the **fingernail** and **plectrum pizzicato** in this way.

Moreover, the bow-screw *pizzicato* is seldom used on the harp and guitar. However, for instance in the case of the harp, a **tuning key pizzicato** is more natural¹. Due to its similarity, the method of notation introduced for the bow-screw *pizzicato* in the string instruments' figure 7 can be employed. Hence the action of plucking the string with the tuning key may – as apparent from figure 255 – be either requested by means of the direction *pizzicato della chiave* (key *pizzicato*) or the direction *pizzicato* and a symbol for the screw. Any other **pizzicato with items** may be requested in the same way and hence either by means of a direction or a symbolic representation of the item. However, it needs to be noted that a graphic depiction of the item contains, in most cases, a greater degree of instantaneous comprehension.

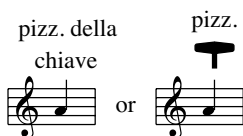

Fig. 255 The tuning key *pizzicato*.

Further, the **lateral Bartók pizzicato** may also be produced on the guitar and harp. In the case of the guitar, the player pulls the low E-string to the side instead of upwards. When doing so, the string bounces back on the fretboard and may even hit adjacent strings. In the case of the harp, this kind of *pizzicato* is normally executed on the lower strings². It can be depicted by means of a variation of the symbol used for the *Bartók pizzicato* (⊖) and a common note head that determines which string is supposed to be plucked. However, the harpist is sometimes required to pull two adjacent strings in

¹ Cf. Stone, *Notation*, pp. 251f.

² Cf., for instance, Kelemen, *Changeant*, p. 8.

opposite directions and let them bounce against each other¹. In such a case, the method of notation can be extended in order to depict the action adequately. As apparent from the example presented in figure 256, the player is supposed to play a lateral *Bartók pizzicato D/D2* with the right hand and a lateral *Bartók pizzicato C/C2* with the left hand. Because the line of the lower *pizzicato* is pointing to the right, the harpist is supposed to pull these two adjacent strings in opposite directions. As a result, the strings bounce against each other and a buzzing sound evolves.

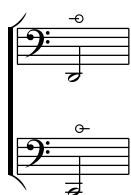

Fig. 256 The lateral *Bartók pizzicato* on two adjacent strings.

Moreover, such a buzzing may also be produced when plucking single or several strings in a very loud manner² or executing a loud *glissando*³. Further, the so-called extended *tremolo* and trill need to be discussed here because there is an unconventional variant of these techniques. This articulation may be referred to as *bisbigliando*, but is also known as unison tremolo, enharmonic or timbre trill. If requested on plucked instruments, the player is supposed to repetitively produce the same pitch on two different strings in a rapid succession. As shown in section ‘3. 1 Extended *vibrato*, *tremolo* and trill techniques and their notation’, the *bisbigliando* may be either defined as an enharmonic trill or overtone *vibrato*. Therefore, it is – as apparent from figure 257 – depicted by means of a trill symbol and the natural sign or a *vibrato* symbol and the direction *bisbigliando*. When executing this articulation on a harp, two adjacent strings need to

¹ Cf. Mauricio Kagel: *Heterophonie*. For orchestra. Frankfurt/M. et al. 1969, p. 14.

² Cf. Kagel, *Anagrama*, p. 32.

³ Cf. Luciano Berio: *Sequenza II*. For harp alone. London 1965, no page named [foreword].

be tuned to the same pitch. In the example an enharmonic trill or overtone *vibrato* $c\sharp^1/C\sharp^4$ is played. Hence the adjacent D-string needs to be previously tuned to $d\flat^1/D\flat^4$. Additionally, the pitch of the second string could be depicted in brackets. As mentioned, it needs to be admitted that – even though the technique is sometimes referred to as an enharmonic or timbre trill – it may be confusing to depict it in this way since a trill is normally associated with changes in pitch.

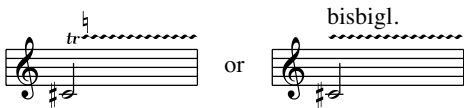

Fig. 257 The *bisbigliando* effect.

When the harpist or guitarist is supposed to repetitively pluck a single string, a *tremolo* may be simply notated. Moreover, the pinch-pizzicato refers, as mentioned, to the string being plucked by two fingers. However, because the sound-wise result is not very different from the common way of performing a *pizzicato*, this technique is neglected here and rather regarded as a means of expression. Further, three other techniques that are related to performing the trill or *pizzicato* – the extended trill with items, *pizzicato* on the neck/in the headstock and the *buzz-pizzicato* – are discussed in sections ‘5. 4. 3 The utilisation of beaters and its notation’, ‘5. 5 Playing exceptional spots’ and ‘5. 7. 1 Exact muting stops and their notation’.

5. 2 Common and extended playing positions on the string and their notation

The **common playing positions** are discussed here because – especially on the guitar – they are not clearly defined. Lachenmann, for instance, differentiates in *Salut fir Caudwell* between four positions: at the bridge, almost on the bridge, the ordinary

position and *tasto*¹. As these positions resemble the playing positions on string instruments, they may be notated in the same manner and hence by means of the directions *sul ponticello*, *ordinario* and *sul tastò*. The additional position designated by Lachenmann as almost on the bridge may analogously be referred to as *quasi sul ponticello*, abbreviated *quasi s. p.* Concerning the common playing positions on the harp, most composers distinguish three or less positions: close to the soundboard or *sulla tavola*, on the midpoint of the string or *ordinario* and close to the neck or *sulla mensola*². Further, it might be desirable to request additional positions on the lower strings, such as *quasi sulla tavola* or *quasi sulla mensola*.

On the guitar the technique of **fingering in between fingerboard and saddle** may be employed. When the left hand leaves the fretboard and slides into the space between fingerboard and saddle, the method of notation needs to be augmented. This is because the sounds that evolve do not have a definite pitch. As shown in section '2. 4. 2 Fingering in between fingerboard and bridge and its notation', this articulation may be depicted by means of a string clef system and triangular note heads pointing upwards. However, it needs to be extended in order to depict six instead of four strings. The system employed here consists of five lines and replaces the traditional system. Each spacing in between the lines and the space above the highest and below the lowest line refers to one of the six strings. For the guitar four distinct stops are also determined: position 1 can be described as the closest to the fretboard. It is depicted by the accidental \flat and can be fingered when playing *ordinario*, *quasi sul ponticello* or *sul ponticello*. The next two positions are located closer to the saddle. Position 2 is

¹ Cf. Helmut Lachenmann: *Salut für Caudwell*. For two guitarists. Wiesbaden 1985, no page named [foreword].

² Cf. Kagel, Sonant, pp. 20f. [explanation of symbols], Kelemen, Changeant, p. 4 or Karlheinz Stockhausen: *Kontra-Punkte*. For ten instruments. London 1953, p. 1.

requested when no accidental is employed whilst position 3 is depicted by the accidental #. These positions may be fingered when playing *quasi sul ponticello* or *sul ponticello*. Moreover, position 4 can only be fingered when playing *sul ponticello*. It is notated by the accidental ✕ and is the closest to the saddle. In the example presented in figure 258, the string clef system is displayed. The described positions are depicted in the order of position 1 on the low E-string, position 2 on the D-string, position 3 on the H/B-string and position 4 on the high E-string.



Fig. 258 Fingering in between fretboard and saddle.

Concerning this technique, there is – apart from considering the additional playing position *quasi sul ponticello* – no distinction made between string instruments and the guitar in order to preserve uniformity. This means that even though it might be possible to produce more sounds on a guitar than a violin by fingering more than four positions, it is neglected here in order to enable the application of the same method of notation for strings and the guitar. Moreover, in order to produce similar sounds as on string instruments, the guitar, however, needs be bowed (cf. section ‘5. 4. 2 The utilisation of a bow and its notation’). Otherwise, varying muted plucking noises are produced.

Another special guitar technique is to finger the string on a fret instead of in between two frets. The result is that the tone is slightly muted and an additional buzzing sound evolves. Kagel depicts the **fingering on the fret** in *Sonant (1960/....)*¹ by means of notating a ‘B’² (as in the German *Bund*, meaning fret). Another variant would be to introduce a special symbol. As the fingering of special positions on the string is, in this

¹ Mauricio Kagel: *Sonant (1969/....)*. For guitar, harp, double bass and membranophones. Frankfurt/M. et al. 1964.

² Cf. Kagel, *Sonant*, p. 19 [appendix].

work however, uniformly depicted by means of special note heads (cf. section ‘2. 4 Extended playing positions on the string’), such a method of notation is favoured here. The note head used to notate playing on the fret is suggested being x-shaped. This is because, in this case, the pitch is augmented by a noise component, and x-shaped note heads are normally used to depict such sounds. When utilising these note heads in combination with a pitch-based notation system, it is, however, described that the noise is complemented by a definite pitch (also cf., for example, section ‘3. 9. 1 Key/valve clicks’). Thus fingering the first fret of the lower E-string would, for instance, be requested by notating a (written) *f/F3* and utilising an x-shaped note head.

Further, the articulation of **bowing on the saddle** is not discussed here because this technique is primarily applied on string instruments (bowing on the bridge). However, in the case of using a bow to play the strings of a guitar, it may also be requested to bow on the saddle of a guitar. In such a case, the method of notation suggested in section ‘2. 4. 3 Bowing on the bridge’ – which implies requesting this technique by means of the string clef system and squared note heads – may be employed. Further, on some guitar models the action of **playing behind the saddle** may be executed¹. As shown in section ‘2. 4. 4 Playing behind the bridge’, this articulation may be requested by means of the string clef system and x-shaped note heads.

Additionally, a technique often employed as an extended *glissando* on string instruments, can also be performed on the guitar. This technique is referred to as **playing on the fretboard**. For instance, Lachenmann requests the guitarist in *Salut für Caudwell* to pluck directly at the stopping finger². As shown in section ‘2. 2. 2 The bow-*glissando*’, an action of this kind may be depicted by means of an additional notation system placed

¹ Cf. Sevsay, Handbuch, p. 248 and Luciano Berio: Sequenza XI. For guitar alone, no page named [foreword].

² Cf. Lachenmann, Salut, no page named [foreword].

above the one that depicts the stops while the playing position on the fretboard is notated by diamond-shaped note heads:



Fig. 259 Playing on the fretboard.

In the example presented in figure 259, the player is supposed to finger a (written) $c^1/C4$ for the duration of a semibreve. The string is plucked here on the fretboard position $c^\sharp/C^\sharp4$ and hence close to the stopping finger. As the action of plucking is only of short duration, it is depicted by a semiquaver (also cf. section ‘5. 3. 1. The progressive modification of the point of plucking’). This method of notation may also be applied in the case of the left-hand *pizzicato* and any other right hand articulation on the fingerboard, e. g. bowing (cf. sections ‘5. 1 Extended *pizzicato*, *tremolo* and trill techniques and their notation’ and ‘5. 4. 2 The utilisation of a bow and its notation’). Additionally, the upper system could, as mentioned, be designated as ‘right hand’ in order to clearly distinguish it from the left-hand system.

5.3 Extended *glissando* techniques

Various extended *glissando* techniques may be executed on plucked instruments. One is the **progressive modification of the point of plucking**. Moreover, the **pitch bending technique** may also be performed on both instruments whilst the **vertical *glissando* with/without plucking** is a harp technique. However, it resembles the technique referred to as the **harmonic-*glissando* without plucking** on the guitar. Further, because the methods of notation for the **basic *glissando* techniques on the harp** suggested by

Stone¹ and Sevsay² are confusing, they need to be discussed here. Finally in the case of the harp, a special *glissando* technique, referred to as the **pedal-glissando**, may be executed.

5. 3. 1 The progressive modification of the point of plucking and its notation

The modification of the point of plucking on plucked instruments resembles the technique referred to as the bow-*glissando* on string instruments (cf. section ‘2. 2. 2 The bow-*glissando*’). As shown there, changing the point of bowing may be requested by means of the common *glissando* notation and the additional direction *glissando d’arco*. This method of notation may be transferred to plucked instruments. However, since the string is played with the hands, the direction *glissando del mano* (*glissando* with the hand) needs to be employed. The progressive modification of the point of plucking it is, in the strict sense, not a *glissando* because the fingers do not slide over, but simply move on the string. However, it may be notated in the same way as the bow-*glissando* because both techniques strongly resemble each other. The technique is in figure 260 depicted by taking the example of the guitar. As shown above, four different playing positions – *sul tasto*, *ordinario*, *quasi sul ponticello* and *sul ponticello* – are determined for this instrument. In the example the guitarist is supposed to play two (written) *tremolo pizzicati* $c^1/C4$ and $c^\sharp/C\sharp4$ for the duration of a minim. During these the point of plucking is constantly modified. In order to depict the duration of these ‘*glissandi*’, an additional notation system is used. By means of this system it is requested that the point of plucking is changed from the initial position to *sul tasto* for the duration of a dotted crotchet. Subsequently, the hand is moved to the position *sul ponticello* for the

¹ Cf. Stone, Notation, pp. 236-239.

² Cf. Sevsay, Handbuch, pp. 224-230.

duration of a quaver. During the plucking of the $c\sharp/C\sharp4$, the hand moves to the position *ordinario* for the duration of a quaver, then to *quasi sul ponticello* for the duration of another quaver and remains on this position until the end of the *tremolo pizzicato*.

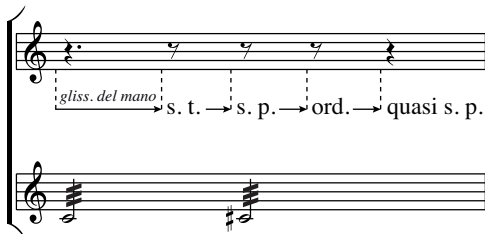

Fig. 260 The progressive modification of the point of plucking on the guitar.

The additional system used here is a treble clef system because it would also be employed when playing on the fretboard (cf. figure 18 in the chapter on string instruments). In such a case, the position on the fretboard would – as in figure 259 – be depicted by means of diamond-shaped note heads whilst the *glissando* notation and the direction *glissando del mano* would request to progressively move the hand on the fretboard.

On the harp the ‘hand-*glissando*’ can be notated by means of an additional single lined notation system with no clef and the plucking positions determined in the previous section. However, it may be not adequately executed on the highest strings. Moreover, an additional notation system can also be dismissed when depicting motions between the common plucking positions (cf. figure 17 in the chapter on string instruments). There is no need to utilise more than these 3 to 5 playing positions because the sound-wise difference is negligible. Nevertheless, in the case of combining certain articulations, such as the extended *battuto* with exact muting stops (cf. sections ‘5. 4. 4 Extended *battuto* techniques and their notation’ and ‘5. 7. 1 Exact muting stops and their notation’), it may be desirable to request the playing positions in a more exact way because various different sounds could then be produced. As it is shown in section

‘5. 3. 3 The vertical *glissando* with/without plucking’, the string can be, for instance, also divided by means of its nodal points (and muting stops). Hence the playing position may be determined by the pitch-based notation system. However, this would lead to confusion in the case of the harp because, for example, the playing position *ordinario* and the first partial (octave) are both located on the midpoint of the string, whereas, in the case of the guitar and string instruments, the normal playing positions are located in between the fretboard/fingerboard and bridge and the other nodal points (and muting stops) on the fretboard/fingerboard. When the right hand/bow is supposed to slide on the fingerboard an additional notation system is, therefore, used. The transfer of this method of notation to the harp, could, however, lead to an unclear appearance of the score and confusion since one or two additional pitch-based notation system would have to be introduced. Moreover, the common playing positions and the nodal points or muting stops may coincide. Therefore, it is suggested here only using the described 3 to 5 directions in order to determine the playing positions.

5. 3. 2 The pitch bending technique and its notation

The pitch bending technique may on the harp be executed in two ways, either by inserting the wooden part of the tuning key between two strings, pluck one of them and twist the key in order to raise the pitch slightly¹ or by pressing the string prior to, simultaneous with or after the plucking². In the case of the guitar, the pitch may be raised by pulling the string to the side prior to, simultaneous with or after plucking it³. As shown in sections ‘3. 4 Pitch bending – the extended *glissando*’ and ‘4. 3 ‘Pitch’ bending – the extended *glissando*’, the technique is, in this work, depicted by means of

¹ Stone, *Notation*, p. 229.

² Cf. Sevsay, *Handbuch*, p. 242.

³ Cf. *ibid.*, p. 247.

an additional notation system, referred to as the transposition system. Another discussion of this technique is, therefore, dismissed here. The x-axis of the transposition system represents, as usual, the duration and the y-axis the degree of the transposition. Moreover, the white dots (◊) depict the degree of the transposition in time.

The pitch bending technique is in figure 261 notated by taking the example of the harp. In this case, the two pitch bending techniques need to be distinguished. The first technique is referred to as *transposizione della chiave* (transposition by the key) and the second as *transposizione del mano* (transposition by the hand). There are four levels for upward transpositions whilst the lowest axis (0) depicts the unbent sound. In the example the harpist plucks the string twice and bends the first tone $c^1/C4$ with the key and the second tone $d^1/D4$ with the hand. The first tone is raised to level 3/4 for the duration of a dotted crotchet. After a quaver rest the player plucks the second tone. Because it is already supposed to be transposed to level 4/4 in the beginning, the already bent string is, in this case, plucked. The pitch is then lowered to level 1/4 for the duration of a minim.



Fig. 261 Pitch bending on the harp.

The pitch bending technique may be depicted similarly on the guitar. However, in this case, no distinction between different bending techniques needs to be made. Moreover, bending *vibrati* can be performed on the guitar and harp. On the guitar it is executed by moving the bent string quickly up and down, whereas on the harp the player pushes and

releases the string in fast succession¹. In such cases, the *vibrato* symbol may complement the dots in the transposition system.

5.3.3 The vertical *glissando* with/without plucking

Vertical motions on the strings of a harp can be executed with the fingers/hand, the fingernails or items, such as the tuning key or a brush. These slides may be performed as distinct articulations or in combination with a *pizzicato* played by the other hand. When only a sliding motion is executed, whistling sounds are produced and when the plucking and vertical *glissando* are employed in combination, harmonics evolve in the case of sliding over or resting on the nodes².

5.3.3.1 Previous methods of notation

Most composers notate the vertical *glissando* in an approximate way. In *Changeant* Kelemen depicts the string upon which the motion is performed in brackets and replaces the note head with an arrow in order to request a vertical *glissando* up- or downwards:



Fig. 262 Kelemen, *Changeant*, p. 46.

Sevsay and Stone suggest a similar method of notation with the difference that they distinguish between slow and fast vertical slides. Fast slides are notated by means of two lines that complement the note head and an arrow head pointing up- or downwards

¹ For the latter cf. Sevsay, *Handbuch*, p. 236.

² Cf. Stone, *Notation*, pp. 251-256.

whilst slow slides are notated by means of two lines and an additional oblique arrow pointing up- or downwards. Additionally, a Pan-pipe symbol, which depicts the produced sound, is employed. This approach is presented in figure 263. Further, when the slides are supposed to be executed with the fingernails, a fingernail symbol is utilised¹.

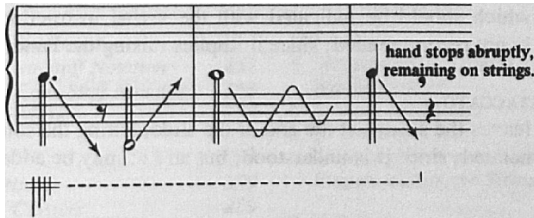

Fig. 263 Stone, Notation, p. 255.

Moreover, Kagel, in *Anagrama*, depicts the extent of the *glissando* by means of the regular playing positions *près des chevilles* (here referred to as *sulla mensola*) and *près de la table* (here referred to as *sulla tavola*). As apparent from figure 264, the vertical *glissando* itself is requested by means of additional arrows and the direction string *glissando* with plectrum or tuning key [Saitenglissando mit Plectrum oder Harfenschlüssel].

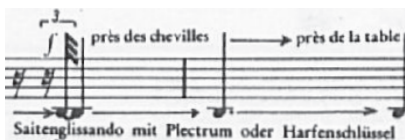

Fig. 264 Kagel, *Anagrama*, p. 9.

Further, Holliger, in *Partita (II)*², employs a vertical *glissando* with plucking. Here the harpist is supposed to slide on the string with the tuning key or a metal stick and pluck the string with the left hand. As apparent from figure 265, he makes use of the conventional harmonic notation for the harp – including the actual pitch (always

¹ Cf. Sevsay, *Handbuch*, pp. 230-232 and Stone, *Notation*, pp. 253-256.

² Heinz Holliger: *Partita (II)*. For harp. Mainz 2004.

$c^2/C5$) that is produced in this way – in order to depict this articulation. In the beginning of the example the harpist is supposed to produce harmonics. Subsequently, the player is required to move the key/stick along the string¹, thereby passing the same nodes. The vertical motion on the string is notated by means of treble clef system.

The image shows a musical score for a harp. The top staff is in treble clef and contains several measures of music. Above the staff, there are instructions: "calmo (ca. 48)", "Stimmsschlüssel (od. Metallstab) - Gliss." (with a square symbol), and "(mit l. H. zupfen) (pluck with left hand)". Below the staff, there are markings: "klingend / actual pitch", "sul Fa", "poco f espr.", "gliss.", and "p". The bottom staff is in bass clef and contains several measures of music. Below this staff, there are markings: "mf", "p", and "5:4" ratios. The score includes various rhythmic patterns, including triplets and 5:4 ratios.

Fig. 265 Holliger, Partita (II), p. 20.

5. 3. 3. 2 Discussion

Kelemen's approach towards the notation of the vertical *glissando* (cf. figure 262) is very inexact. This is because he neither defines the starting point nor the endpoint of the motion, but merely determines the direction of the *glissando*. By contrast, the method suggested by Stone (cf. figure 263) is more exact because two speed levels – slow and fast – are determined. These levels resemble the tempo index introduced in section '4. 2. 4 Rubbing and bowing motions'. It is utilised in the case of repetitive rubbing motions on percussion instruments because they do not have a fixed endpoint. However, when the starting point and endpoint may be determined, it is more exact and simpler to do so instead of depicting a speed level. The performance speed may then be derived from the duration of the action and the extent of the motion.

One approach towards the determination of the vertical motion's extent is presented by Kagel. As can be seen in figure 264, he depicts it by means of the regular playing

¹ Cf. *ibid.*, p. 20.

positions. The more playing positions are introduced, the more exact can the extent of the motion be described. However, the most exact method of notation is utilised by Holliger who makes use of harmonic notation (cf. figure 265). As a reminder, the second to fifth partial are often requested on the harp. The partials are produced by touching the respective node on the string. For the second partial the string is touched in the middle, for the third partial it is touched after 1/3, for the fourth partial after 1/4 and for the fifth partial after 1/5 of the string length (always starting from the neck). The second partial is requested by notating a circle over the plucked note itself and the other partials are depicted in the same way as on string instruments¹:



Fig. 266 Sevsay, Handbuch, p. 238.

Thus four different positions may be determined by means of harmonic notation and *glissandi* between these positions be performed. As apparent from figure 265, Holliger also requests vertical motions beyond the nodal points. However, the method of notation he employs is confusing because it suggests fingering a certain nodal point, but the resulting pitch is actually different from the pitch that evolves when fingering this node. Therefore, it would be clearer to depict the attachment of an item or finger on the nodes simply by means of a common note (which determines the string that is subject to the sliding motion) and a circle above it or an additional diamond-shaped note head (which determines the node that is touched) and any motion beyond the nodes also by means of diamond-shaped note heads. As shown in section ‘2. 2. 1 The harmonic-*glissando* without bowing and its notation’, diamond-shaped note heads may be used to depict any fin-

¹ Cf. Sevsay, Handbuch, pp. 237f.

gering position on a particular string. As harp strings behave in the same way as the strings of, for instance, a violin, the method of notation introduced in this section may be transferred to this plucked instrument. It needs to be, however, noted that the fingering positions cannot be defined by means of a fingerboard in the case of the harp. Nevertheless, the player may on the harp easily determine the nodal points by hearing (because a certain harmonic is produced) whilst all other positions can be determined with regard to the normal behaviour of strings (in the case of minor seconds, the string is touched after 1/10 of the string length and, in the case of major seconds, after 1/9 of the string length etc.). When attaching the fingers beyond the nodal points, no harmonics are produced, but the string is actually muted. However, when attaching an item, such as a bottleneck or the harp's tuning key, to off-node positions, the pitch depicted by the diamond-shaped note head is produced. Additionally, the string upon which the *glissando* is executed may not be determined in the same way as on string instruments (e. g. *sul E, A, D, G*), but simply be depicted by a common note. The described approach may also be used to depict motions on the strings that have not been plucked. Since no harmonics evolve, all positions on the string should be notated by means of diamond-shaped note heads (e. g. the middle point of the string $c^1/C4$ by a diamond-shaped note head on position $c^2/C5$).

5. 3. 3. 3 Suggestion for the notation of the vertical *glissando* with/without plucking

Vertical *glissandi* are hence notated similarly to the harmonic-*glissando* without bowing on string instruments. Suchlike motions may on the harp preferably be executed on the lower strings and cannot be performed on the highest strings. When requesting a vertical *glissando*, the fingers may, for instance, slide from the minor second position (which requests that the string is touched after 1/10 of the string length and hence, in the

case of the longest string (150 cm), after 15 cm, starting from the neck) down to the quadruple octave position (which requests that the string is touched after 15/16 of the string length and hence, in the case of the longest string, after approximately 141 cm).

In figure 267 all vertical motions are executed on the $c^1/C4$ string. It is in the beginning plucked and vibrates – due to playing *non lasciar vibrare* – for the duration of a minim (for the subsequent muting of plucked strings cf. section ‘5. 6 Muting and its notation’). During this time a *glissando* with the tuning key is executed, starting on the second partial (octave). The key is then moved to position $g^1/G4$ (third partial) for the duration of a quaver, to $c^{\#3}/C\#6$ for the duration of another quaver and finally to $f^1/F4$ (fourth partial) also for the duration of a quaver. The next motion can be described in the same way. However, this time the string is not plucked (*non pizzicato*). Therefore, the harmonic notation for the second partial is replaced by a diamond-shaped note head on position $c^2/C5$. When the string is not plucked, no sound is produced when the key rests. Therefore, the *glissando* ends when the $e^1/E4$ is reached and a demisemiquaver is applied pro forma. Alternatively, the vertical *glissando* may also be depicted by means of two systems (one for the plucking/basic string and one for the *glissando* with the key).

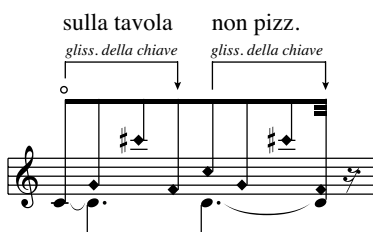

Fig. 267 The vertical *glissando* with/without plucking.

As it is always requested by means of harmonic notation, the vertical *glissando* can be distinguished from the basic *glissando* on the harp. Further, the dynamic level of the vertical *glissando* without plucking is low when executed with the hand or fingers, but

may be increased by using the fingernails or items (cf., for instance, section ‘5. 1 Extended *pizzicato*, *tremolo* and trill techniques and their notation’ for the depiction of the fingernails and items). Moreover, it can be also executed on more than one string simultaneously and/or with both hands. When the player is supposed to slide on a cluster of strings, the harmonic cluster notation presented in figure 280 may be utilised. In the case of utilising both hands to perform a vertical *glissando* without plucking, the method of depiction from figure 267 needs to be simply employed for the left and right hand. As mentioned, the *glissando* is in this work – in order to achieve a greater clearness and to enable the depiction of sliding motions that do not imply a gliding change of pitch – requested by means of an arrow and not in the traditional manner. Alternatively, the common method of depiction may be restored.

5. 3. 4 The harmonic-*glissando* without plucking and its notation

As mentioned in the previous section, diamond-shaped note heads may be used to depict the position of a finger or item on a string in the case of the *harmonic-glissando* on string instruments. As the guitar and all string instruments strongly resemble each other concerning this articulation, it may be notated in the same way as suggested in section ‘2. 2. 1 The harmonic-*glissando* without bowing and its notation’. The string(s) upon which the slide is executed may also be determined by means of directions (*sul e*, *B*, *G*, *D*, *A*, *E*), but the direction *senza arco* needs to be, in the case of the guitar, replaced by the direction *non pizzicato*. Moreover, the guitarist may also be requested to scratch over the fretboard by giving the direction *il tasto* as well as to execute a harmonic-*glissando* with the fingernails or items (cf. figure 4 and 9 to 11 in the chapter on string instruments). The dynamic level may – in comparison to string instruments – become slightly higher when sliding over the strings of an acoustic guitar or the

fretboard of a classical/acoustic guitar. When the performance of a harmonic-*glissando* is supposed to be executed with the right hand or both hands, this method of notation can likewise be used (cf. also section ‘2. 2. 2 The bow-*glissando*’). Further, especially the execution of a harmonic-*glissando* with a bottleneck is employed very often on the guitar while the bottleneck can be depicted by means of a symbol or direction (cf. figure 11 in the chapter on string instruments).

5.3.5 *Glissando* variants on the harp and their notation

The basic *glissando* on the harp is strictly speaking not a *glissando* because this technique does actually not imply a gliding change of pitch, but gliding from one string to another. However, the term *glissando* is, in this work, utilised to describe all sorts of gliding motions and, therefore, also employed for horizontal gliding motions on the strings of a harp. Further, Sevsay presents various basic *glissando* techniques and methods of notation. They are adopted from Salzedo’s *Modern study of the harp*¹. In order to clarify these, the most important ones are discussed here and methods suggested that comply with the notation of the basic *glissando* on the other instruments.

The normal *glissando* is in the compendium referred to as *flux éoliens*. When executing this technique *sulla tavola*, the *glissando technique* is called *flux hautboïstique*. Moreover, a *glissando* with the fingernails is referred to as *flux en grêle* and a *glissando* with the nails *sulla tavola* as *xyloflux*. These techniques may be depicted by means of the common *glissando* notation and – dependent on the articulation – an additional fingernail symbol (cf. inter alia figure 4 in the chapter on string instruments) and/or the direction *sulla tavola*. Another technique, designated as *bruissement éoliens*, refers to a tetrad *glissando*. Sevsay suggests a special method of notation, which inter alia implies

¹ Cf. Salzedo, Study, pp. 1-14.

the lowest and highest tone of the chord and oblique arrows. However, since it is sufficient to employ the standard *glissando* notation and depict all tones of the chord in the beginning and at the end of the *glissando*, another method does not have to be employed. Further, a very rapid *glissando* is referred to as *accords en jet* and also depicted in a special manner. However, when the starting point, endpoint and the duration of the *glissando* is given, the harpist knows how fast the *glissando* is supposed to be executed. Therefore, the standard *glissando* notation can also be applied in this case. Further, the term *trémolo éolien* refers to a repetitive *glissando* executed in between two tones. *Sevsay* suggests notating this technique by depicting the two tones and utilising a *tremolo* symbol. However, a *glissando* of that kind is in section ‘2. 2. 2 The bow-*glissando*’ defined as a trill-*glissando*. This is because a repetitive gliding switch between two tones is executed instead of a *tremolo*, which would signify that the amplitude is modulated. Therefore, the method of notation for the so-called *trémolo éoliens* makes use of the *glissando* notation in combination with the common way of depicting a trill. As in figure 268 an augmented trill – which exceeds the normal trill intervals – is requested, the two tones $g - e^b^2/G^3 - E^b^5$ are notated and additionally written in brackets. The player is in the example hence requested to perform a repetitive *glissando* motion from g/G^3 to e^b^2/E^b^5 .



Fig. 268 The *trémolo éoliens* or trill-*glissando*.

Finally, *Sevsay* even suggests a special method of depiction for a sequence of *glissandi*. The technique designated as ascending/descending eolian chords refers to playing the first *glissando* with one finger, the next *glissando* with the next finger etc. However,

this technique may also be depicted in the conventional manner by notating a *glissando* from, for instance, a very low tone to a low tone, then a *glissando* from a high tone to a higher tone etc. The order of the fingers can be depicted as on the piano, e. g. 1, 2, 3 etc. However, the impact of determining the fingers is quite low. Alternatively, the graphic depiction of the hand introduced in the string instruments' figure 93 could be employed in order to request the utilisation of particular parts of the hand when executing a *glissando*¹ (cf., for instance, figure 313 in the chapter on keyboard instruments).

5.3.6 The pedal-*glissando*

The pedal-*glissando* is a harp technique. It is normally performed simultaneous with, or subsequent to, plucking a string. When the pedal position is changed, the pitch may – dependent on the previous position – be raised and/or lowered. Moreover, when adjusting the pedal in between two positions, microtones are produced. Additionally, a trill-*glissando* may also be played with the pedals. Moreover, solely the alteration of the pedal position may be used as an effect. In such a case, the string is not plucked. However, it needs to be noted that this effect is controversial because some harpists contend that it is damaging to the mechanism. As a reminder, the left foot controls the D-, C- and H/B-pedal and the right foot the E-, F-, G- and A-pedal. Two adjacent pedals may only be moved simultaneously when the starting point and endpoint of the motion is equal, e. g. $F\# - G\#$ to $F - G^2$.

¹ Cf. Sevsay, Handbuch, pp. 224-230.

² Cf. Sevsay, Handbuch, pp. 218f., 232f., 239 and 241 and Stone, Notation, pp. 242f.

5.3.6.1 Previous methods of notation

There are mainly two different ways to notate this articulation. One is to depict the *pedal-glissando* underneath the harp's notation systems. This method is employed by Berio in *Sequenza II*. As apparent from figure 269, the harpist is supposed to change the position of the F-pedal from *F* to *F#*, then to *Fb* and back to *F*. Simultaneously, a normal *glissando* from *a/A3* to *G/G2* (the system is in bass clef) is played with the left hand for the duration of a quaver and a rapid repetitive sequence, which inter alia involves the *f1/F4* (the system is in treble clef), is played with the right hand.

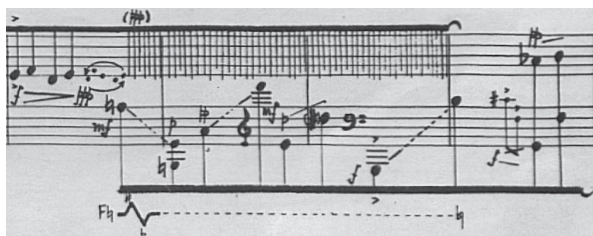

Fig. 269 Berio, *Sequenza II*, p. 1.

In *Sonant (1960/....)* Kagel notates this articulation similarly. Changing the pedal position (which is, in this case, referred to as a *portato*) is requested by means of an arrow and a trill-*glissando* by a waved line:

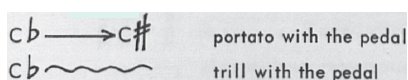

Fig. 270 Kagel, *Sonant*, p. 21.

The other method of notation is to give the direction *pedal-glissando* and depict the extent of the *glissando* by means of transposed notes. Holliger, in *Partita (II)*, makes use of this method. As can be seen in figure 271, the harpist is supposed to execute a *pedal-glissando* from *D/D2* to *D#/D#2* for the duration of a semiquaver, then back to *D/D2* for the duration of quaver and finally to *Db/Db2* for the duration of a semiquaver.



Fig. 271 Holliger, Partita (II), p. 24.

Moreover, both methods can also be used in combination and *glissandi* to microtones be depicted by means of microtonal accidentals¹.

5.3.6.2 Discussion

When depicting the pedal-*glissando* in the same manner a change in the pedal positions is requested, the articulation may be easily comprehended by the harpist. However, Berio notates the pedal positions by means of a diagram² and the pedal-*glissando* by characters, accidentals and a line (cf. figure 269), which leads to confusion. The method of depiction could be, however, easily simplified by notating both – a change in the pedal positions and the pedal-*glissando* – similarly. Hence when willing to depict the pedal-*glissando* by means of characters, accidentals and a line, the pedal position should as well be notated in this way, e. g. *D, C#, B/Bb // E, F#, G, Ab*. Moreover, in *Sequenza II* the duration of the pedal-*glissandi* is only determined approximately. A greater degree of exactness could be gained by depicting the duration either by means of the harp's notation system or introducing a distinct timeline for the pedal. Further, because any kind of *glissando* is, in this work, depicted by means of arrows, and there is no need to further emphasise that the pedal is lifted or lowered when giving directions, such as *F*, *F#* and *Fb*, Kagel's method of depicting the pedal-*glissando* (cf. figure 270) is preferred to Berio's approach. Hence it is favoured here to use an arrow instead of Berio's line.

¹ Cf. Sevsay, Handbuch, pp. 232f.

² Cf. Berio, *Sequenza II*, p. 1.

However, it might be helpful to outline that a *pedal-glissando* is performed by giving a direction, such as *pedal-glissando* or *glissando del pedale*. Moreover, concerning the *trill-glissando* with the pedal, it may be stated that Kagel's approach needs to be extended in order to depict the trill in the conventional and a more exact manner. Thus trill and *glissando* symbols, which depict the extent of the *trill-glissando*, should be instead used.

Furthermore, Holliger's method of notation (cf. figure 271) may be easily comprehended when only one string is involved in the *glissando*. However, it becomes confusing when several strings are plucked and only some of them are involved in the *glissando*. Moreover, it cannot be employed when, for instance, a normal *glissando* is used in combination with a *pedal-glissando*. Because the harpist is used to the depiction of the pedal position by means of diagrams, symbols or characters and accidentals, it is also simpler to depict the *pedal-glissando* in this fashion.

5.3.6.3 Suggestion for the notation of the *pedal-glissando*

The *pedal-glissando* is notated here by means of characters, accidentals, arrows and giving the direction *glissando del pedale*. Further, an additional timeline is introduced in order to depict the duration of the *pedal-glissando* independently from the harp's notation system. As apparent from figure 272, the player is initially supposed to execute a *glissando* upwards, starting from *a/A3* and pluck the chord *G – c – d/G2 – C3 – D3*. Both the *glissando* and the *pizzicato* have the duration of a minim. Simultaneously, the harpist is requested to move the D- and C-pedal from *D – C* to *D# – C#* for the duration of a quaver, then back to *D – C* for the duration of a semiquaver, to *Db – Cb* for the duration of another semiquaver, subsequently to *D – C* for the duration of a quaver and finally to *D# – C#* for the duration of another quaver. Additionally, the right foot

executes a trill-*glissando* $A - A\flat$, which ends on the $A\flat$. The resulting pedal positions are then depicted in brackets. After the pedal-*glissando* has ended, the harpist plays a $b^1/B\flat 4$ and the chord $G - c\sharp - d\sharp\ll/G2 - C\sharp 3 - D\sharp 3$.

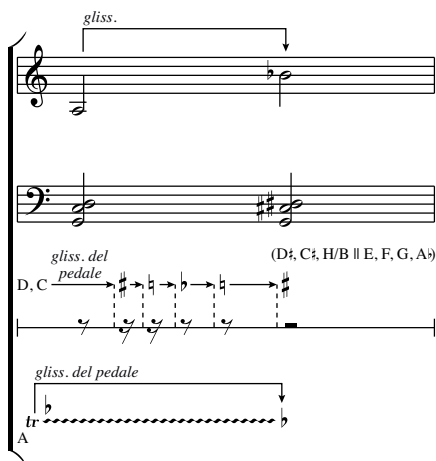

Fig. 272 The pedal-*glissando*.

There is no need to use a timeline for the trill-*glissando* because it lasts as long as the normal *glissando*. When wanting to depict the duration of two pedal-*glissandi* independently from the harp's notation system, they can either be notated by means of the same timeline or two independent ones. Further, when the pedal is supposed to be adjusted between two positions, a microtonal symbol requesting a quarter tone above/below the middle position \natural can be employed (or a quarter tone below the bottom position \sharp and a quarter tone above the top position \flat , respectively). Microtonal symbols are, in this work however, not discussed. Pedals can also be constantly adjusted to such a half depressed position, but, in such a case, the foot that adjusts the pedal needs to hold it when playing the respective microtone and cannot simultaneously set other pedals¹. Additionally, a so-called rattling effect is obtained by half depressing the pedal². Further, the production of pedal 'noise' can be requested similarly to the pedal-

¹ Cf. Sevsay, Handbuch, p. 239.

² Lachenmann, Gefühle, no page named [foreword].

glissando. When the pedals are moved vigorously and the strings not plucked, the strings anyway start to vibrate. In the case of using this effect, the additional direction *lasciar vibrare* should complement the pedal-*glissando*. The dynamic level of the pedal ‘noise’ is always very low.

5. 4 Extended modes of attack

One extended mode of attack explained in this section can be described as touching the string after the attack. It is referred to as the *toccato*. There are a further two main extended modes of attack with items. One involves the **utilisation of a bow** and the other one the **utilisation of beaters**. The latter is principally an extended harp technique. Additionally, so-called **extended *battuto* techniques** may be executed. These articulations are mainly related to the guitar, but may in some cases also be employed on the harp. Further, **strumming** is a guitar technique that needs to be discussed here because there is no conventional method of notation for this articulation.

5. 4. 1 The *toccato* and its notation

The *toccato* articulation has been extensively discussed in section ‘2. 3. 3 The *saltando*, *balzando* and *toccato* and its notation’. As shown there, it can be notated by simply giving the direction *toccato*, depicting the string that is touched by a common note head and determining the playing position. In the case of the harp, this action may be, for instance, executed by means of the tuning key (*colla chiave toccato*), and on the guitar it may be additionally performed on the fretboard. In the case of the latter, the method of notation presented in figure 259 needs to be combined with the direction *toccato*. Further, any item or beater can be used for this technique (cf. section ‘5. 1 Extended *pizzicato*, *tremolo* and trill techniques and their notation’ for the depiction of the tuning

key and other items as well as section ‘5. 4. 3 The utilisation of beaters and its notation’ for the depiction of beaters). When the string has been played and still vibrates, a sound effect occurs. Moreover, another *toccato* articulation, referred to as the *buzz-pizzicato*, is discussed in section ‘5. 7. 1 Exact muting stops and their notation’ because it is related to the depiction of muting stops.

5. 4. 2 The utilisation of a bow and its notation

The utilisation of a bow on the harp and guitar is strongly related to the common usage of the bow on string instruments and can hence be depicted in a similar manner. Therefore, the conventional method of notation used to request the utilisation of the bow on strings may be transferred to the harp and guitar: the direction *arco* or *con/col arco* should be used when the player is required to bow the strings of these instruments, the produced tone should be depicted and the playing position be notated. Moreover, when plucked instruments are bowed, the type of bow may be determined (e. g. contrabass bow), a so-called *glissando d’arco* be performed (cf. section ‘2. 2. 2 The bow-*glissando*’), all parts of the instrument be bowed (cf. section ‘2. 5 Playing exceptional spots’) as well as other conventional and unconventional bowing techniques be requested. In such cases, the conventional methods of notation or the ones presented in the chapter on string instruments, may be easily transferred. However, it needs to be noted that, in the case of the harp, the bow needs to be tilted when bowing the strings, so that no other string is touched¹. Therefore, the manoeuvrability of the bow is limited.

¹ Cf. Holliger, Partita (II), p. 16.

5. 4. 3 The utilisation of beaters and its notation

Beaters are primarily used on the harp, but may also be utilised to strike the strings of the guitar or string instruments. As apparent from the chapter on percussion instruments, beaters are always depicted by means of symbols. Further, the standard utilisation of beaters on the harp is strongly related to striking mallet instruments and, therefore, can be depicted by means of the conventional method of notation employed for these instruments. Hence when beating the strings of a harp or executing *glissandi*, a beater symbol can be used in combination with a depiction of the strings that are struck or involved in the *glissando*. Additionally, the playing position needs to be described. Moreover, most extended harp techniques and several extended beaters attacks, such as plucking the string with a beater, modifying the point of impact, executing a vertical *glissando* with/without plucking, striking with the handle of a beater or entire length of a stick, rubbing motions with beaters on the body as well as the stop attack, can be performed on the harp. They may be depicted by using the paradigms presented in figure 255 (extended *pizzicato*), 260 (modification of the point of plucking) and 267 (vertical *glissando*) in combination with a beater symbol as well as by transferring the methods apparent from figure 194 (common and extended attacks), 219, 220 (rubbing and bowing motions) and 251 (stop attack) in the chapter on percussion instruments. Moreover, strokes on the bodies of plucked instruments are discussed in section ‘5. 8 Percussive effects and their notation’.

Further, most of these attacks may be employed on the guitar and string instruments. However, the articulation referred to as the basic *glissando* on the harp, is on the guitar and strings referred to as strumming and discussed in the following section while the vertical *glissando* is on these instruments described as a harmonic-*glissando* without

plucking/bowing (cf. sections ‘5. 3. 4 The harmonic-*glissando* without plucking and its notation’ and ‘2. 2. 1 The harmonic-*glissando* without bowing and its notation’).

Another extended technique – which is primarily employed on the harp, but may also be transferred to the guitar or string instruments – is to insert an item (e. g. a tuning key, plectrum, metal stick, pencil or nail) in between two strings and repetitively hit these. *Sevsay* describes this kind of action as a *tremolo* and suggests notating it in this way¹. However, it is not actually the amplitude that is modulated (as in the case of a *tremolo*) since a rapid alteration between two tones is executed (as in the case of a trill). Nevertheless, this **extended trill with items** cannot be depicted by means of a trill symbol because trills are normally plucked on the harp and on the guitar and string instruments executed with the left hand. Hence the utilisation of a trill symbol would in this context lead to ambiguity. Instead, the articulation is rather regarded as a rare extended beater technique. In order to notate it in a simple manner, a sketch of the action is employed here. This is because it is, as mentioned, the most comprehensible and simplest method of depiction.

As can be seen in figure 273, the player is supposed to perform an extended trill *sulla tavola* with a tuning key and then a plectrum in between the strings $c^1/C4$ and $d^1/D4$. These actions are notated by means of two notes that depict the tones, a description of the playing position, the symbol for the tuning key or plectrum (cf. section ‘5. 1 Extended *pizzicato*, *tremolo* and trill techniques and their notation’) and a sketch of the action. Each trill lasts for the duration of a minim.

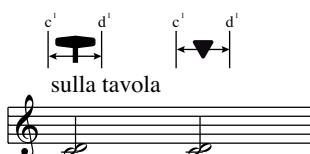

Fig. 273 The extended trill with items.

¹ Cf. *Sevsay*, Handbuch, p. 244.

When transferring this articulation to the guitar or string instruments, fingerings may be additionally employed and only four to six strings need to be depicted (e. g. on the guitar by the indications e, H/B, G, D, A, E). Further, the playing position may on all instruments be modified during the extended trill with items or when playing with beaters (cf. section ‘5. 3. 1 The progressive modification of the point of plucking and its notation’).

5. 4. 4 Extended *battuto* techniques and their notation

Extended *battuto* techniques have been discussed in section ‘2. 3. 2 Extended *battuto* and *tratto* techniques and their notation’. As shown there, *battuto* articulations that involve the screw of the bow or items may be depicted by means of a direction for or presenting a symbol of the item and giving the additional direction *battuto*. Such a ***battuto with the screw/with items*** may be transferred to the harp and guitar. As these techniques may be used in a similar manner on plucked instruments, they can be notated in the same way. The position on the string can be, in the case of the harp, depicted by means of the common playing positions and be modified. In the case of the guitar, it may be notated by means of the common playing positions and the method employed for playing on the fretboard (cf. section ‘5. 3. 1 The progressive modification of the point of plucking and its notation’). Further, it is possible on the guitar to produce tones by fingering the strings without plucking. When doing so, the finger needs to hit the string with force and push it against the fretboard. As shown, this articulation is regarded as a **left-hand *battuto*** and can be depicted by giving the direction *battuto* (*mano sinistra*) as well as notating the produced tone (also cf. figure 32 and 35 in the chapter on string instruments for the *battuto* on the fingerboard and the left-hand *battuto*).

5.4.5 Strumming and its notation

Strumming is a standard guitar technique, which may also be employed on string instruments, especially on the violin or viola when playing *al mandolino* with a plectrum (cf. section ‘2. 1 Extended *pizzicato* techniques and their notation’). As mentioned, this technique resembles the *glissando* on the harp. However, it can be, in the case of the guitar and strings, not notated in this way because the common *glissando* is executed with the left hand on these instruments.

Most composers notate the articulation by means of a symbol derived from the notation of *arpeggi*. This is because the articulation is also strongly related to strumming. For instance, Brouwer, in *Elogio de la danza*¹, depicts a downbeat (motion from the highest to the lowest string) by means of an arrow pointing downwards and an upbeat (motion from the lowest to the highest string) by means of an arrow pointing upwards placed over the notation system:



Fig. 274 Brouwer, *Elogio*, p. 5.

Further, Kagel places such an arrow in *Heterophonie* in front of the chord² and Crumb uses the *arpeggio* symbol in order to request strumming in *Mundus canis* (“A dog’s world”)³. However, Crumb’s method of notation is confusing because it suggests that an *arpeggio* is the same articulation as strumming. By contrast, when playing *arpeggi*, the string is plucked and, in the case of the strumming, the hand glides over the

¹ Leo Brouwer: *Elogio de la danza*. For guitar. London et al. 1972.

² Cf. Kagel, *Heterophonie*, p. IX.

³ Cf. Crumb, *Mundus*, p. 5.

string. Therefore, Brouwer's and Kagel's methods are preferred to that of Crumb. When compared, Kagel's method of notation is closer related to traditional notation because it is employed in the same way as the *arpeggio* symbol and, therefore, favoured. Further, the action of strumming does not only resemble the *arpeggio*, but also the up- and down-bow motion on string instruments. However, the notation of this action by means of up- and down-bow symbols should not be employed because this could lead to confusion when using this technique on strings. As can be seen in figure 275, the player is supposed to strum the (written) chord $c^1 - g^1 - d^2/C4 - G4 - D5$ twice (upbeat, downbeat) with the hand and hence in the normal way. Subsequently, the same chord is strummed twice (downbeat, upbeat) with a plectrum (cf. section '5. 1 Extended *pizzicato*, *tremolo* and trill techniques and their notation' for the notation of the plectrum).



Fig. 275 Strumming.

5. 5 Playing exceptional spots and its notation

Two exceptional spots may be played on plucked instruments. In the case of the harp, the player may pluck the strings **on the neck** above the tuning pins and, in the case of the guitar, **inside the headstock**. All other techniques are related to the utilisation of a bow: on the harp the body and different parts, such as the tuning pins and pedals, and on the guitar the body and parts, such as the tuning pegs, nut or headstock, may be bowed. The methods of notation for these actions may be derived from the paradigms presented in section '2. 5 Playing exceptional spots' (also cf. section '5. 4. 2 The utilisation of a bow and its notation').

The action of plucking the strings on the neck is strongly related to plucking string instruments inside the pegbox. As shown in section ‘2. 5. 3 Playing the tuning pegs, peg box and scroll’, the latter articulation is notated by means of the string clef system and spherical note heads. However, even though the two techniques resemble each other, the method of notation cannot be transferred in its full extent. This is because the string clef system may not be employed on the harp. Nevertheless, plucking on the neck may be, in this case, simply requested by means of spherical note heads and a pitch-based notation system that determines the string that is plucked. When requesting this technique, it needs to be taken into account that the pedal position does not have an impact on the produced sound. Therefore, all accidentals can be dismissed¹. A suggestion for the notation of this technique is presented in figure 276. As can be seen there, the harpist is supposed to pluck the strings in the order of *d/D3*, *G/G2*, *A/A2* and *e/E3* on the neck. The dynamic level of this articulation is always low².



Fig. 276 *Pizzicato* on the neck.

Plucking inside the headstock of a guitar is likewise strongly related to the technique of plucking inside the pegbox of string instruments. In this case, the string clef system may be, however, employed. The articulation may be on the guitar, therefore, requested by means of spherical note heads in combination with the string clef system (cf. figure 258 as well as figure 78 in the chapter on string instruments). As in the case of the harp, the dynamic level of the articulation is always low.

¹ Cf. Sevsay, Handbuch, p. 243.

² Cf. *ibid.*, p. 243.

5. 6 Muting and its notation

This section mainly focuses on the muting of the harp. This is because the execution of exact muting stops is regarded here as the common way of muting the guitar and subsequent muffling does not need to be specifically requested. With regard to the harp, the muting position also has an impact on the produced sound. This technique is, however, discussed in section ‘5. 7. 1 Exact muting stops and their notation’. Moreover, when all strings of a harp (or guitar) are supposed to be muted, the instrument can be prepared, e. g. by inserting a strip of paper between the strings. Such actions are discussed in section ‘5. 9 Preparing the instrument and its notation’. Besides these preparations, there is one muting variant on the harp and guitar. It may be described as muting the string with the palm whilst simultaneously plucking it with the same hand. This constant muffling resembles the **application of mutes**. As shown in section ‘3. 8. 1 The application of mutes’ and ‘4. 4. 2 Hand muffling and its notation’, it can be notated by giving the direction with/without mute (hand) or *con/senza sordino (mano)*. When playing in this way, the dynamic level is always low.

Further, the **hand muffling** of the harp strongly resembles the execution of this technique on mallet instruments. As this muting technique has been extensively discussed in section ‘4. 4 Muting’, another discussion is dismissed here, but the methods of notation transferred to the harp. There are – according to Sevsay – mainly three subsequent muting techniques on the harp. The first technique is defined by him as the normal muting and refers to the muting of tones according to their duration¹. This is valid for playing *non lasciar vibrare* because the tones are then supposed to be muted according to the depicted duration and no specific muting symbol is necessary. However, when playing *lasciar vibrare*, hand muffling needs to be specifically requested. As

¹ Cf. *ibid.*, p. 233.

can be seen in figure 277, only the muting sign may be employed when it distinctly requests that all tones played by one hand are muted simultaneously. When the tones are, however, supposed to be muted in a sequence, the muting sign needs to be used in combination with a depiction of the string that is muted (cf. figure 248 and 249 in the section on percussion instruments).

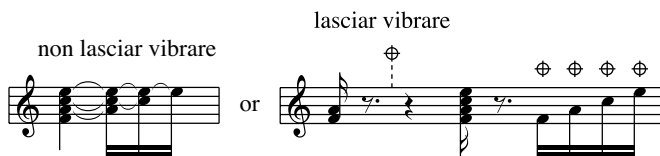

Fig. 277 The normal muting.

Further, Sevsay refers to a second muting technique as isolated tones or *sons isolés*. It implies that one tone is plucked and muted exactly when the next tone is played¹. When playing *non lasciar vibrare*, this technique may be simply requested by notating a sequence of tones and – optionally – *staccato* dots. However, when playing *lasciar vibrare*, another method of notation needs to be employed. As apparent from figure 278, the harpist is supposed to pluck an *f*/*F*4 and mute it exactly when the next tone *g*¹/*G*4 is played. Because such an action cannot be depicted by means of a single notation system, two systems are employed.



Fig. 278 Isolated tones (*lasciar vibrare*).

¹ Ibid., p. 233.

The third technique is called *sons étouffés*, damped tones. However, it merely refers to a subsequent muting that is requested by means of the muting sign. Therefore, it does not differ from the normal muting when playing *lasciar vibrare*. Further, Sevsay describes variants of the *sons étouffés*, e. g. muting only some of the strings that have been previously plucked, muting a set of pitches or muting in a sequential manner¹. All of these variants may be depicted by means of the paradigm presented in figure 277.

5.7 Extended stopping techniques

There is one extended stopping technique that may be employed on the guitar and harp. It is referred to as **exact muting stops**. The examination of this articulation implies the description of the *buzz-pizzicato*. Additionally, on the guitar **half harmonic stops** may be executed and *barré stops* be requested.

5.7.1 Exact muting stops and their notation

As mentioned in section ‘2.6.2 Exact muting stops and their notation’, diamond-shaped note heads are commonly used to depict harmonics. They can also be utilised for the depiction of muting stops because the pressure that is applied to the string is similar to when fingering harmonics. When the string is fingered on an off-node position with the same pressure, it is muted². Owing to the similar nature of the guitar and string instruments, the method of notation suggested in the chapter on string instruments can be easily transferred to this kind of plucked instrument. Moreover, the same is valid for the harp. In the case of this instrument, only a very limited number of muting stops may be, however, executed on the highest strings. The method of notation for off-node posi-

¹ Cf. *ibid.*, pp. 234f.

² Cf. Leo Brouwer: *La espiral eterna*. For guitar. Mainz 1973, p. 7.

tions may be derived from the method of depiction for harmonics with diamond-shaped note heads (cf. figure 266). When requesting muting stops on the harp, the player needs to be simply advised to finger an off-node position. As can be seen in figure 279, the harpist is supposed to play four quavers *d/D3*, *G/G2*, *A/A2* and *e/E3*. When plucking these tones, the string is at the same time touched at an off-node position (here constantly a tritone, starting from the neck).



Fig. 279 Exact muting stops on the harp.

When the strings of a harp are muted close to the soundboard, the produced sound is referred to as xylophonic tones or *sons xylophoniques*. Moreover, when muting stops are executed approximately in the middle of the string length (beyond the nodal point) and plucked *sulla tavola*, they are referred to as xylophonic sounds *a la guitarra*¹. This technique may be further extended by using the whole hand, the tuning key or foreign objects, such as a threaded rod or a long wooden stick, instead of the fingers. When doing so, a larger range of strings may be simultaneously muted. These extended muting stops may be notated in the same way as the basic muting stops. However, an additional direction, such as with the tuning key or *con/col chiave*, or a symbol for the foreign object should be additionally employed when using items and not the hand (cf. sections ‘5. 1 Extended *pizzicato*, *tremolo* and trill techniques and their notation’ and ‘5. 4. 4 Extended *battuto* techniques and their notation’). Moreover, when a set of pitches or a cluster, respectively, is supposed to be muted, a special method of notation needs to be employed. This is because the utilisation of common notes in combination

¹ Cf. *ibid.*, pp. 235f.

with diamond-shaped note heads would lead to an unclear appearance of the score. Such an **exact cluster muting stop** is requested here by means of a squared cluster note (cf. sections ‘6. 6. 1 Clusters’ and ‘6. 6. 3 Exact muting stops/harmonics and their notation’ for a detailed explanation of this technique) – which depicts the muted strings – and a cluster of diamond-shaped note heads. In figure 280 the player is required to mute the cluster *A/A2* to *h/B3* on the tritone position *eb/Eb3* to *f^l/F4* (only the lowest and highest tone of these clusters is notated exactly) for the duration of a minim. In this case, he uses a threaded rod to mute the strings. This item is depicted here by means of a symbol. Alternatively, it could be notated by means of a direction. The additional direction *non battuto* is given to outline that the threaded rod is simply used to perform a muting action. During the muting the harpist plays four quavers *d/D3*, *G/G2*, *A/A2* and *h/B3*. The *G/G2* is, in this case, not muted. In order to facilitate the notation of cluster muting stops (or harmonics), the muting position should be the same for each string. Otherwise, the appearance of the score could become unclear. Moreover, when muting strings with items, an additional buzzing sound may occur.



Fig. 280 Cluster muting with a threaded rod.

Further, the **buzz-pizzicato** is executed on both – the harp and guitar – in the same way as on string instruments. Therefore, the method of notation presented in the string instruments’ figure 89 may be transferred to the plucked instruments. As mentioned in the section on the *buzz-pizzicato*, there are three variants of producing it: 1. By slightly

touching the lingering string with the fingernail after a *pizzicato*. 2. By slightly touching the lingering string with the fingertip after a *pizzicato*. 3. By slightly touching the string with the fingernail during the performance of a *pizzicato*. In the case of variants 1 and 2, a *pizzicato*-sound is followed by a buzzing whilst, in the case of variant 3, a *pizzicato*-sound and buzzing blend. In figure 281 the method of notation suggested in the chapter on string instruments is transferred to the harp. The *toccato* action may – in the case of variant 1 – be notated in the same way as the common *toccato* (cf. section ‘5. 4. 1 The *toccato*’) and – in the case of variants 2 and 3 – by means of the *toccato* and harmonic notation. All actions are performed on the *f^l/F4*-string. In the example all three variants of the buzz-*pizzicato* are displayed: 1. The player performs a demisemiquaver *pizzicato sulla tavola f^l/F4* and subsequently touches the string with the fingernail on the *sulla tavola* position for the duration of a semiquaver. The *legato* slur underlines that the string is not previously muted, but the tone still lingers when the string is touched after a demisemiquaver (the *legato* slur only needs to be employed on the harp when playing *non lasciar vibrare*). 2. The player performs a *pizzicato f^l/F4* and subsequently touches the string with the fingertip on the position *g^l/G4* for the duration of a semiquaver. The *legato* slur emphasises that again the *f^l/F4* still lingers and the string is additionally touched after a demisemiquaver. 3. The player performs a *pizzicato* and simultaneously touches the string with the the fingernail on position *g^l/G4*. The direction *pizzicato e toccato* is used – instead of merely depicting a fingernail muting stop that is plucked – in order to outline that a fingernail *pizzicato* is not supposed to be executed, but a fingernail *toccato*.

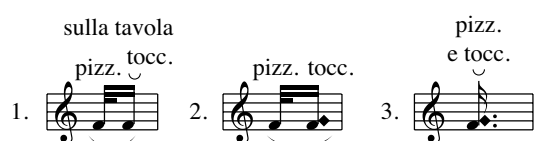

Fig. 281 The buzz-*pizzicato* on the harp.

5.7.2 Half harmonic stops and their notation

Half harmonic stops are a guitar technique. As on string instruments, the applied finger pressure is higher than when stopping harmonics and lower than when fingering normal tones. However, when executing half harmonic stops on the guitar, the string hits the frets when plucked and hence a buzzing sound evolves. This technique is most effective on the lower strings. Because the half harmonic articulation on the guitar is nevertheless strongly related to the performance of this technique on string instruments, it may be notated in the same way as suggested in section ‘2.6.1 Half harmonic stops and their notation’. The employed method of notation hence makes use of diamond-shaped note heads to depict the stopping position and a complementary white and black diamond-shaped symbol placed above the note in order to request the stopping technique. As mentioned, diamond-shaped note heads are employed since the fingering of half harmonic stops is rather a variation of fingering harmonics than normal tones.

5.7.3 *Barré* stops and their notation

Barré stops are a guitar technique. They can be defined as using the index finger to simultaneously depress all strings on the same fretboard position. This technique is discussed here because Lachenmann, in *Salut für Caudwell*, employs a special method of depiction in order to notate these stops. As can be seen in figure 282, he makes use of diamond-shaped note heads (to depict harmonic fingering) and notates only the highest and lowest tone of the stop in order to request the *barré* stop.

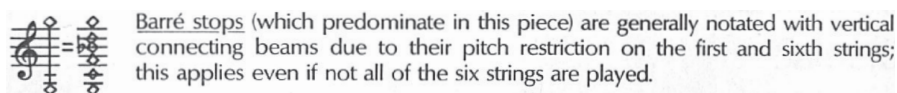

Fig. 282 Lachenmann, *Salut*, no page named [foreword].

Moreover, Lachenmann introduces an additional system that is used to describe which string is in combination with the constantly fingered *barré* stop plucked¹. However, the utilisation of two systems complicates the notation of normally fingered tones/harmonics/muting stops because they could be sufficiently depicted by utilising only one notation system. Further, there is no need to alter the conventional method of notation for stops when requesting this special fingering technique². However, it could be helpful to additionally depict the *barré* chord when the player is supposed to constantly finger it whilst only plucking, for instance, single strings. The fingered chord could, in such a case, be notated in brackets above the normal notation system.

5. 8 Percussive effects and their notation

Percussive effects may be produced on the body (or other parts) of the harp and guitar as well as on their strings. In the case of the harp, the hands or items may be used to strike the neck, shoulder, column, pillar, soundboard etc. of the instrument. However, it needs to be noted that sharp-edged items should not be utilised³. As shown in section ‘2. 7. 1 Strokes on the body and their notation’, hits on the body of an instrument may be depicted by means of a drawing of the instrument’s body – which enables the determination of the point of impact – in combination with a drawing of the player’s hand. When items are supposed to be used, another symbol replaces the drawing of the hand (cf., for instance, section ‘4. 1. 1 Special agents of attack and its notation’). In figure 283 various **strokes on the body** of a harp are requested. They are executed in the order of with the knuckles on the column – with the side of the fist on the soundboard – with the palm on the shoulder – with the index, middle and ring finger on the

¹ Cf. Lachenmann, *Salut*, pp. 1ff.

² Cf. the augmented *barré* stop in Leo Brouwer: *Obras para guitarra*. Cuaderno I. Cuba 1982, p. 12.

³ Cf. Sevsay, *Handbuch*, p. 244.

crown – with the tip of the thumb, index and middle finger on the soundboard – with the tip and fingernail of the index finger on the soundbox. All actions are separated by quaver rests (also cf. figure 92 to 94 in the chapter on string instruments) and performed with the left hand. When the right hand is supposed to be used, a mirror inverted drawing of the harp should be used. However, in this case, it needs to be considered that the upper part of the instrument's body is resting against the right shoulder.

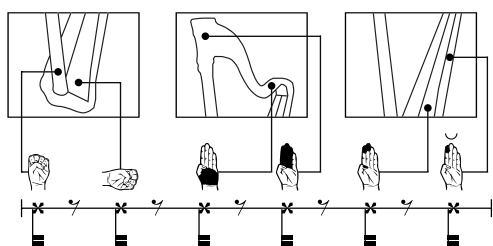

Fig. 283 Strokes on the body of a harp.

Further, a special striking technique may be executed on the harp. It is referred to as *sons timbaliques* (timpanic tones). When requested, one finger of the right hand dabs the resonating area of the soundboard whilst the left hand plucks the string¹. In order to depict *sons timbaliques*, two notation systems need to be used, one that depicts the plucked string and one that depicts the dabbing of the resonating area. Because this spot varies according to the string that is plucked and needs to be determined in a very exact way, a drawing of the instrument cannot be, in this case, used. Varèse notates this action in *Amériques*² by means of an additional enclosed 'T' placed above the note³. Another variant would be to simply give the direction *son timbalique* or *suono timpanico*, employ a drawing of the hand and depict the percussive effect – as usual – by means of x-shaped note heads in a single lined notation system with no clef:

¹ Ibid., p. 245.

² Edgard Varèse: *Amériques*. Performance edition prepared form the original manuscript by Chou Wen-chung. San Giuliano Milanese 1997.

³ Varèse, *Amériques*, p. 1.

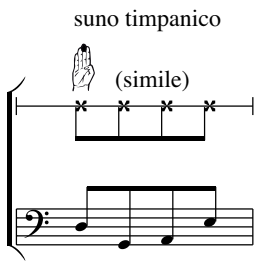

Fig. 284 *Sons timbaliques*.

Additionally, Sevsay mentions the rare **anvil effect**. It is produced when the tip of the tuning key is used to stroke the brass plate, which is located over the tuning pins¹. This articulation resembles two techniques, the bow-*glissando dietro il tasto* and simple rubbing motions, as employed on the strings of a snare drum (cf. sections ‘2. 2. 2 The bow-*glissando*’ and ‘4. 2. 6 Playing the snares’). In order to depict the anvil effect in accordance with these articulations, a special notation system, which consists of two components – a traditional timeline and a representation of the length of the brass plate – may be employed. Additionally, a sketch might have to be used in order to outline what the player needs to do to produce the desired sound (cf. figure 20 and 21 in the chapter on string instruments). The tuning key should be, in this case, depicted by means of a symbol and the utilisation of its tip be requested by an additional little arrow (cf. figure 186 as well as figure 194 in the chapter on percussion instruments).

As mentioned in section ‘2. 7. 2 Strokes on the strings and their notation’, **strokes on the strings** may be described as stop attacks executed with the hand. Because this technique is on string, percussion and plucked instruments executed in a similar manner, it can be notated in the same way and hence by utilising a symbol of the hand, a muting sign (\oplus) and determining the playing position (cf. figure 96 in the chapter on string instruments). Further, in the case of the guitar, dead strokes on the fretboard may be

¹ Sevsay, Handbuch, p. 245.

requested. When executing dead strokes with the hand, it does not make a difference whether the strings are additionally muted with the other hand or not because they do not vibrate subsequently to the stroke. However, when using a beater or the wood of a bow, the strings linger after the attack. Therefore, the method of notation may be augmented in order to make the player additionally execute exact muting stops (or apply a mute on the harp), which keep the strings from vibrating. Moreover, in the case of the guitar, the string may also be simultaneously depressed. These articulations may be depicted in the same way as in the string instrument's figure 97 (for the other techniques also cf. sections '5. 4. 3 The utilisation of beaters and its notation', '5. 6 Muting and its notation' and '5. 7. 1 Exact muting stops and their notation'). Finally, stop attacks with the right hand's palm are a popular technique on acoustic guitars. They are often used to mute a previously plucked string. In order to depict this, the plucked tone and the stop attack would have to be connected by means of a *legato slur*.

5. 9 Preparing the instrument and its notation

Plucked instruments can be, for instance, prepared by means of the preparations applied to string instruments, such as placing a knitting needle between the strings or muting a number of or all strings with adhesive tape. Further, Varèse, in *Amériques*, requests the player to mute the harp by inserting a strip of paper at the upper extremity of the string¹. Other preparations may involve cloth or foam rubber².

As in the case of the other instruments, there are numerous ways of preparing plucked instruments. Similarly it is also, on the one hand, barely possible to list them all and subsequently develop a coherent method of depiction, whilst on the other hand, it is also

¹ Varèse, *Amériques*, p. 13.

² Cf. Sevsay, *Handbuch*, p. 147

not necessary to do so since most preparations are executed previously to a performance and may be simply described in the foreword to a work. Further, when preparations are supposed to be executed during a performance, they are suggested here being always notated by means of a sketch. This is because it is the simplest way of depicting these. Such a sketch should include the determination of the strings that are prepared, e. g. when only a certain range is muted with adhesive tape. When the sketch is not clear enough, it may be complemented by an explanation (cf. sections ‘2. 8 Preparing the instrument and its notation’ and ‘3. 6. 2 Constructional modifications and their notation’). Nevertheless, preparations may lead to the introduction of new playing techniques that should then be notated in accordance with all other techniques presented in this work.

5. 10 Summary

In this part of the work the unconventional playing techniques of the harp and guitar are introduced, their previous methods of notation discussed and suggestions for their notation presented. In the first section extended *pizzicato* techniques, such as the *pizzicato* with the left hand, the fingernail and plectrum *pizzicato*, the tuning key *pizzicato*, the *pizzicato* with items and the lateral *Bartók pizzicato* – which is executed by pulling (one of) the lowest strings of a guitar or harp to the side – as well as a kind of extended *tremolo* and trill, the *bisbigliando*, are discussed. The next section then focuses on common and extended playing positions on the string. Common playing positions need to be discussed because they are – especially on the guitar – not clearly defined. Moreover, the guitar may be fingered in between the fingerboard and saddle or on the fret, be bowed on the bridge, and some models may even be played behind the saddle. Additionally, the strings of a guitar may also be played/plucked on the fretboard.

Further, there are various extended *glissando* techniques that may be executed on plucked instruments. One is the progressive modification of the point of plucking, which may be executed on the harp and guitar. Moreover, the pitch may be bent on the harp by either inserting the wooden part of the tuning key between the strings, plucking one of them and twisting the key in order to raise the pitch slightly or by pressing the string. In the case of the guitar, the pitch may be raised by pulling the string to the side. Further, on the harp a vertical *glissando* with/without plucking may be employed. It can be executed with the fingers/hand, the fingernails or items. The corresponding articulation is, on the guitar, referred to as the harmonic-*glissando* without plucking. Additionally, there are a number of *glissando* variants on the harp that are described as special techniques in the handbooks, but may be depicted by means of the conventional *glissando* notation. Finally, on the harp a pedal-*glissando* may also be performed. When the pedal position is changed simultaneously with, or subsequent to, plucking a string, the pitch may be raised and/or lowered. Moreover, when adjusting the pedal in between two positions, microtones are produced.

The next section is then devoted to extended modes of attack. One is referred to as the *toccato* articulation and may be described as gently touching the string with the hand or an item after the attack. Further, the guitar and harp may be played with a bow and struck with beaters. Moreover, extended *battuto* techniques may also be employed on both instruments. They can be executed with any kind of item whilst on the guitar a left-hand *battuto* (tapping) may also be performed. Further, strumming is a standard guitar technique. However, since no conventional method of notation has yet been established, it is also discussed in this way. Furthermore, two exceptional spots may be played on plucked instruments. In the case of the harp, the player may pluck the strings on the neck above the tuning pins and, in the case of the guitar, inside the headstock. The next

section then focuses on the muting of the harp. It may be either constantly muted by means of the hand or subsequent to the attack by hand muffling. Further, there is one extended stopping technique, referred to as exact muting stops, that may be employed on the guitar and harp. Moreover, in the case of the harp, string clusters may be also muted by means of items and on both instruments exact muting stops be further extended by using the fingernail instead of the bow to mute the string during the performance of a *pizzicato*. This technique can then be described as one variant of the *buzz-pizzicato*. The other variants are to slightly touch the lingering string with the fingernail or fingertip after a *pizzicato*. Additionally, half harmonic stops – which are executed by applying finger pressure that is higher than when fingering harmonics and lower than when fingering normal tones – and *barré* stops – which are performed by using the index finger to simultaneously depress all strings on the same position – can be performed on the guitar.

The next section is devoted to percussive effects, including strokes on the body of a guitar or harp as well as *sons timbaliques* (dabbing the resonating area of a harp's soundboard whilst simultaneously plucking the string), the anvil effect (stroking a harp's brass plate located over the tuning pins with the tip of the tuning key) and strokes on the string of a guitar or harp (stop attack). Further, the final section focuses on the preparation of plucked instruments and portrays some of the preparations that may result in new playing techniques being created.

6. THE TECHNIQUES OF KEYBOARD INSTRUMENTS

The chapter on keyboard instruments solely focuses on the grand piano. All other keyboard instruments, such as the upright piano, organ, harpsichord or celesta, are not discussed here specifically in order to limit the extent of the work. Nevertheless, many augmented techniques that may be employed on the piano can be easily transferred to the other keyboard instruments. In the case of the grand piano, there are two main playing positions: at the keys and inside the piano. The pianist himself may play inside the piano from the keyboard position when the lid is open or removed. Additionally, an assistant located at the rear end of the instrument can also play inside the piano while the pianist is playing at the keys. As many extended techniques that may be executed on the strings of a piano strongly resemble the techniques of the harp (and other plucked or string instruments), the methods of notation presented in the previous chapter may often be simply transferred. In such cases, a detailed discussion of the technique is dismissed, but merely the suggested method of notation presented. It needs to be further noted that – according to Sevsay – playing inside the instrument may be only performed on pianos, not on the harpsichord and celesta. Sevsay explains that the sensitivity of the harpsichord does not permit any playing inside the instrument and it is not possible to reach the interior of a celesta¹. However, for instance, Essl makes a performer play inside a harpsichord in *Sequitur XII*² and execute several extended articulations, such as vertical *glissandi* on the strings, *pizzicati* on the strings as well as the production of harmonics by touching the strings³. Further, Boulez, in *Improvisation II sur mallarme*⁴

¹ Cf. Sevsay, Handbuch, pp. 268f.

² Karlheinz Essl: *Sequitur XII*. For harpsichord and live-electronics. No city named 2009.

³ Cf. *ibid.*, no page named [foreword].

⁴ Pierre Boulez: *Improvisation II sur mallarme*. For soprano and 9 instrumentalists. London 1958.

requests playing inside a celesta¹. When employing them in a careful way, the utilisation of suchlike techniques should hence be possible on the harpsichord and celesta.

With regard to the grand piano, the notation of the trill, the common articulations (*legato*, *staccato* etc.), the ordinary utilisation of the three pedals and the (rare) *scordatura* are regarded here as conventional². Their notation can be accessed through the essential handbooks on instrumentation whilst most composers use the method of depiction that can be found there (also cf. the introduction to the chapter on string instruments for the notation of microtones). Whereas, the main unconventional elements of sound production presented in this chapter are extended *pizzicato* techniques, common and extended playing positions on the string, the common and extended *glissando*, extended modes of attack, muting, extended stopping techniques, pedal effects, percussive effects and preparing the instrument. Concerning the dynamic level of these articulations, indications are – as far as possible – presented when the execution of the action is, in terms of the loudness, limited.

6.1 Extended *pizzicato* techniques

All *pizzicato* techniques on the piano are extended techniques. The pianist may play a ***pizzicato on the keys*** as well as the pianist or assistant perform a ***pizzicato on the strings***.

6.1.1 The *pizzicato* on the keys and its notation

The *pizzicato* on the keys is a very rare technique. When employed, the pianist is supposed to pull and pluck the key upwards instead of depressing it. The result is a

¹ Cf. *ibid.*, p. 21.

² Cf. Sevsay, *Handbuch*, pp. 253f. and 266.

subtle click with indefinite pitch. This articulation can be only executed on the white keys. Lachenmann introduces the *pizzicato* technique in *Guero*¹. As obvious from figure 285, he requests it by means of a diamond-shaped note. Moreover, the key that is supposed to be plucked is determined in an approximate manner².

A kind of pizzicato is intended as a further playing technique:



at the front, lateral edge of the key

Fig. 285 Lachenmann, *Guero*, no page named [foreword].

However, the note head Lachenmann utilises is normally used for the notation of harmonics or related techniques. Further, there is no need to determine the key that is plucked in an approximate manner when it can be done in an exact way by means of the pitch-based notation system (although the sound-wise difference between plucking one key or another is admittedly very small). Moreover, because the key *pizzicato* is related to the key/valve clicks on wind instruments – which are requested by means of x-shaped note heads in a pitch-based notation system (cf. section ‘3. 9. 1 Key/valve clicks’) – as well as the normal *pizzicato* articulation, it is suggested here depicting the articulation by means of x-shaped note heads, the traditional notation system and the direction *pizzicato*. Furthermore, Lachenmann also requires the pianist to pluck the tuning pegs³. This technique is, however, discussed in the chapter on percussive effects.

6. 1. 2 The *pizzicato* on the strings and its notation

Concerning the *pizzicato* on the strings, there are a couple of conditions that need to be taken into account. From the pianist’s position all strings may be plucked between the

¹ Helmut Lachenmann: *Guero*. For piano. Wiesbaden 1972.

² Cf. *ibid.*, p. 2.

³ Cf. *ibid.*, no page named [foreword].

tuning pins and the felt strip. However, some of the middle range strings located adjacent to the crossbeam that separates the bass strings from the middle range strings cannot be plucked behind the hammers and dampers because they are completely covered by the bass strings. Since the shape of the metal frame and the number of strings covered by the bass strings is dependent on the model, it is necessary to consider this when requesting the string *pizzicato*:

Vaes presents a listing of 17 piano models that inter alia describes between which intervals the crossbeams are located¹. A similar listing can also be found in ‘Appendix B’. It presents the data by Vaes as well as of several more *Bechstein*, *Bösendorfer*, *Boston*, *Steinway*, *Wendt & Lung* and *Yamaha* models. The Vaes listing does not take into account which strings may not be plucked behind the hammers and dampers. But it is shown in ‘Appendix B’ that 2-3 completely covered strings cannot, on several *Steinway* and *Bechstein* models and even less on the *Bösendorfer* models, be plucked, but the assistant is able to bend forward in order to reach the strings that are partially covered by the bass strings, and the pianist can also play these. Therefore, it can be assumed that normally, at the most, three strings adjacent to the bass strings cannot be plucked. As apparent from ‘Appendix B’, the bass strings’ number may, however, also differ. When utilising techniques that are executed on the strings, it would, therefore, be helpful to refer to the appendix of this work and suggest models upon which these articulations may be performed. Further, the lowest strings of a grand piano consist of a single wire, whereas the strings in the middle range consist of two and the highest strings of three wires. When requesting the player to pluck a string, which is made of two or three wires, the player might wonder whether he should pluck only one of the wires or two/

¹ Cf. Luk Vaes: *Extended piano techniques. In theory, history and performance practice*. No city named 2009, pp. 1032-1048.

three simultaneously. However, because considering these circumstances would lead to a very complex method of notation and is also dependent on the utilised piano model, this aspect is regarded here as a means of interpretation.

The notation of the *pizzicato* on the strings may be regarded as nearly conventional. As any plucking of strings, it is, in most cases, requested by means of the direction *pizzicato*¹. Some composers, however, use a special note head in combination with this direction². Further, when the pianist himself is supposed to pluck the string (or perform other actions on these), the instructions are often boxed in order to distinguish them from playing at the keys:

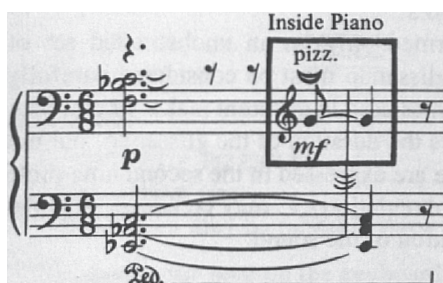

Fig. 286 Stone, Notation, p. 263.

Additionally, Lachenmann, in *Guero*, distinguishes between two playing positions for the pianist: on the strings between the tuning pegs and the felt strip and in the normal (upper) area of the strings, close to the dampers. The first variant is requested by means of a special note head and the second one by means of a common note head³.

Concerning the variants of notation, it may be stated that the *pizzicato* on the strings of a *piano* resembles the *pizzicato* on the strings of a harp. It should be, therefore, nota-

¹ Cf., for instance, George Crumb: *Ancient voices of children*. Soprano, boy soprano, oboe, mandolin, harp, electric piano, percussion. New York et al. 1970, p. 3, Kagel, *Anagrama*, p. 36 or John Cage: *Music of changes II*. New York 1961, p. 2.

² Cf. Lachenmann, *Air*, p. 19 or Karlheinz Stockhausen: *Klavierstück XII*. Examen von Donnerstag aus Licht. As a piano solo. Kürten 1983, p. V.

³ Lachenmann, *Guero*, no page named [foreword].

ted in the same manner and hence simply by means of giving the direction *pizzicato*. However, because some of the techniques that may be performed on the strings by the pianist resemble techniques that may be performed on the keys (e. g. the *glissando*), it needs to be indicated whether the articulation is executed on the keys or strings. Therefore, the approach of using a box is suggested here being employed whenever the pianist himself executes actions on the strings. An alternative method of notation would be to notate these by means of a distinct notation system or give a short explanation when the pianist is supposed to consistently play inside the piano. In the case of the assistant, no boxes need to be utilised because a player standing at the rear of the piano may only perform articulations inside the piano. These actions are suggested here being notated by means of a distinct notation system.

Further, concerning the playing positions, the first position (between the tuning pegs and the felt strip) resembles the *pizzicato* inside the pegbox of string instruments as well as the *pizzicato* on the neck of a harp. As shown in sections ‘2. 5. 3 Playing the tuning pegs, peg box and scroll’ and ‘5. 5 Playing exceptional spots and its notation’, this action is depicted by means of spherical note heads, the additional direction *pizzicato* and – on string instruments – by a string clef system. The same method of notation is also suggested being employed when requesting *pizzicati* ‘in the pegbox/on the neck’ of a piano. However, the normal pitch-based notation system needs to be employed in order to distinguish the strings. Only the pianist himself may pluck the string on this position. Further, he may only play a *pizzicato* at the dampers because the music rest (and score) might otherwise compromise the articulation. However, the assistant may pluck the string on all positions except for in between the tuning strips and felt strip (cf. the following section for the determination of the playing positions).

Moreover, as apparent from figure 286, it is possible to execute some of the extended *pizzicato* techniques explained in section ‘5. 1 Extended *pizzicato*, *tremolo* and trill techniques and their notation’, such as the **fingernail** and **plectrum *pizzicato*** or the ***pizzicato with items***. In the case of these techniques, the methods of notation may be simply transferred from plucked instruments to the piano because the described articulations are strongly related. Hence the fingernail *pizzicato* can be depicted by means of an additional fingernail symbol whilst the utilisation of a plectrum may be requested by employing a drawing of the plectrum and giving the direction *pizzicato*. Any other *pizzicato with items* may be notated by giving a direction or presenting a symbol of the item. Further, another technique that is related to performing a *pizzicato* – the buzz-*pizzicato* – is discussed in section ‘6. 6. 3 Exact muting stops/harmonics and their notation’.

6. 2 Common playing positions on the strings and their notation

As shown in section ‘5. 2 Common and extended playing positions on the string and their notation’, three main playing positions on the strings of a harp are normally requested. As the shape of the harp and the piano (frame) resemble each other, similar playing positions are also suggested here being employed. These playing positions are depicted in the traditional manner and hence by directions: close to the damper or *sul smorzatore*, on the midpoint of the string or *ordinario* and close to the bridge or *sul ponticello*. It needs to be noted that the lowest strings of a grand piano may be longer than those of a harp. Therefore, it may – especially in the case of long pianos – even be more desirable to request additional playing positions, such as *quasi sul smorzatore* or *quasi sul ponticello*. The pianist normally plays *sul smorzatore* because, as mentioned, the music rest might compromise articulations, such as *pizzicato ordinario*, whilst the

assistant may reach any of these playing positions. However, he might not be able to reach the playing position *sul smorzatore* (or *quasi sul smorzatore*) on the bass strings of concert grand pianos, such as the *Bechstein D 282* or *Steinway D-274*, from the rear position. Further, all playing positions may be only plucked on strings that are not covered by the bass strings whilst the partially covered strings may be, in any case, played *sul smorzatore* (cf. ‘Appendix B’). In the case of utilising pianos with additional crossbeams that connect the basic braces (e. g. the *Steinway B* or *D* type¹), the player may simply pluck the string a little further to the dampers or bridge when, for instance, the midpoint of the string is covered by the beam. Concerning the position *sul smorzatore* it needs to be noted that no dampers are applied on grand pianos either from *f#3/F#6*, *g3/G6* or *g#3/G#6* on². However, the position is also designated here as ‘close to the dampers’ for the highest strings.

6.3 The *glissando*

There are four types of *glissandi* on the piano, the common ***glissando on the keys***, the ***glissando on the strings***, the **progressive modification of the point of plucking** as well as the **vertical *glissando on the strings with/without plucking***. They are all unconventional articulations because there is no common method of notation for any of these techniques.

¹ Cf. Vaes, *Extended*, pp. 1042f.

² Cf. Vaes, *Extended*, pp. 1032-1048.

6.3.1 The *glissando* on the keys

Even though the *glissando* on the keys is an old technique, it is still depicted in varying ways. The most common variant is a diatonic *glissando* on the white keys¹. It may be, however, also performed on the black keys or as a chromatic *glissando* on the white and black keys. The technique is sometimes also referred to as an *arpeggio*. However, since, in the case of the *glissando*, the fingers slide over the keys, it is different from an *arpeggio*.

6.3.1.1 Previous methods of notation

Henze in *Sinfonia N. 6*² makes use of a key *glissando* (referred to as *quasi arpeggio*). In this piece the *glissando* is always executed by rolling the palm on the keys. As can be seen in figure 287, the key *glissando* is notated by using several note heads with a similar shape that indicate whether the right or left hand is rolled on the black or white keys from the top to the bottom or the other way round in a slow or fast manner. The pitch is, as apparent from the score, only determined in an approximate way³.

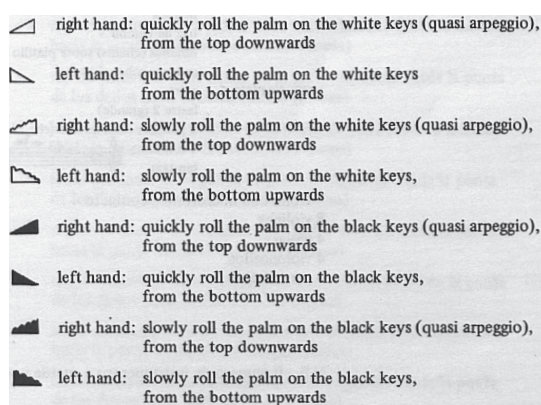

Fig. 287 Henze, *Sinfonia N. 6*, p. 7.

¹ Cf. Sevsay, *Handbuch*, p. 257.

² Hans Werner Henze: *Sinfonia N. 6*. For two chamber orchestras. Mainz 1970.

³ Cf. *ibid.*, p. 129.

Moreover, Kagel, in *Norden*¹, from the cycle *Die Stücke der Windrose*, makes use of a chromatic key *glissando*. It is depicted by means of a variation of the *arpeggio* symbol and several transposed note heads:

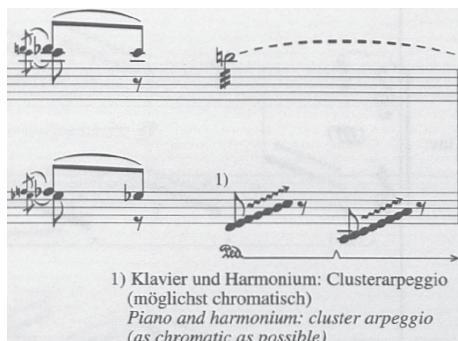

Fig. 288 Kagel, *Norden*, p. 85.

Another more conventional method is to depict all tones that are part of the *glissando* and give the direction *glissando*. This method of depiction has already been applied by Brahms in his *Hungarian dances*². In the example presented in figure 289, diatonic double *glissandi* are supposed to be performed.

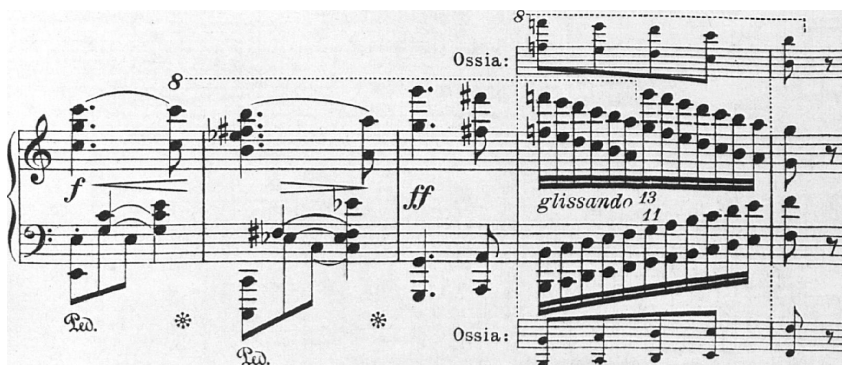

Fig. 289 Brahms, *Hungarian*, p. 28.

¹ Mauricio Kagel: *Die Stücke der Windrose*. Norden. For salon orchestra. Frankfurt/M. et al. 1996.

² Johannes Brahms: *Hungarian dances I and II*. For piano four hands. Mainz and Leipzig no year named [ca. 1920].

6.3.1.2 Discussion

Generally, it needs to be acknowledged that there is a conventional method of notation for the *glissando*, which should be only altered when there is a sufficient reason. Otherwise, the previously defined criteria would be violated. The *glissando* is, in this work, notated in a slightly varying way in order to achieve a greater clearness and to enable the depiction of sliding motions that do not imply a gliding change of pitch. This method (or the conventional one) could basically be used to depict the *glissandi* requested by Henze (cf. figure 287) or Kagel (cf. figure 288). Further, the approach by Henze is very complex and would even have to be extended to request other *glissandi* than the ones he makes use of. Moreover, Kagel's method would also have to be augmented and is related rather to the *arpeggio* than the *glissando* notation. The only sufficient reason for altering the *glissando* notation is that there are three types of *glissandi* on the keys, and it could not be clearly comprehended whether a diatonic *glissando* on the black/white keys or a chromatic *glissando* is requested when only the lowest and highest tone of the *glissando* is given. Nevertheless, since the diatonic *glissando* on the white keys is the most common one and it can be distinguished from the diatonic *glissando* on the black keys when the highest and lowest tone are notated, the conventional method of notation or the extended variant employed in this work, respectively, may be used to request it. Another method needs to be, however, used for the chromatic *glissando*. It may be derived from Brahms' method (cf. figure 289) because this way of depicting the *glissando* is simple, exact and strongly related to traditional notation. However, it is not necessary to depict each tone's duration, but merely the overall duration of the *glissando*. This method could even be used to notate a more complex *glissando* gesture, which, for instance, starts solely on the white keys, is then executed on the white and black keys and ends on the black keys.

6.3.1.3 Suggestion for the notation of the *glissando* on the keys

The diatonic *glissando* on the white/black keys is notated here in the same way as all (pitch) *glissandi* in this work and hence by depicting the starting point and endpoint of the *glissando* and connecting these by an arrow. Moreover, any chromatic or more complex *glissando* is suggested here being notated by determining the starting point and endpoint as well as notating each key the player slides over in brackets. In the example presented in figure 290, four different *glissandi* are performed. The first one is a diatonic *glissando* on the white keys. The *glissando* starts on the $d^1/D4$ and ends on the $a^2/A5$. After the duration of a dotted crotchet, the $a^2/A5$ is reached and depressed for a demisemiquaver. The second *glissando* is diatonic and executed on the black keys. It starts on the $c^\sharp^1/C^\sharp4$ and ends on the $a^\flat^2/A^\flat5$. The third one is a chromatic *glissando* from $a/A3$ to $a^1/A4$, whereas the fourth *glissando* starts on the white keys ($a/A3$ to $d^1/D4$), is then executed on the white and black keys ($e^\flat^1/E^\flat4$ to $g^1/G4$) and ends on the black keys ($a^\flat^1/A^\flat4$ to $e^\flat^2/E^\flat5$). Moreover, any kind of double *glissando* or *glissando* executed with both hands (travelling in the same or opposite direction) may be notated in this manner. Alternatively, the common *glissando* notation may be, in the case of the key *glissando*, also restored.



Fig. 290 The diatonic and chromatic key *glissando*.

Furthermore, the so-called additive/subtractive cluster *glissando* is discussed in section '6.6.1 Clusters' because it is strongly related to the notation of clusters while the *glissando* without depressing the keys is regarded as a percussive effect and, therefore, discussed in section '6.8 Percussive effects and their notation'.

6.3.2 The *glissando* on the strings and its notation

The *glissando* on the strings of a piano strongly resembles the common *glissando* of a harp and may be, therefore, notated in the same manner. When the pianist performs a *glissando*, the action needs to be either boxed or depicted by means of a distinct notation system. When the assistant performs a *glissando*, no special method of notation needs to be employed. However, it needs to be considered that – depending on the framework of the piano model – certain *glissandi* may be executed on one model, but are impossible on the other. In his *Klavierstück XIII*¹ Stockhausen, therefore, mentions that the “*glissandi* on the strings were tried out on a *Steinway B* model grand piano. With differently constructed pianos one may to have to interrupt some *glissandi* at a metal brace and quickly continue on the other side”². Other composers determine four³ or five⁴ registers for the piano and depict all actions on the strings in an approximate way. Kagel mentions that these “registers are defined by the framework of the grand piano. Divergences from the given ranges are, of course, to be decided upon if the framework is laid out differently”⁵. However, since listings of the framework of various piano models are available (cf. ‘Appendix B’), it is possible to depict *glissandi* in an exact manner and suggest models upon which these actions may be performed. An alternative would be to (in the case of the unavailability of suchlike piano models) permit that the *glissandi* with differently constructed pianos may – as in Stockhausen’s *Klavierstück XIII* – be interrupted. Additional crossbeams that connect the basic braces,

¹ Karlheinz Stockhausen: *Luzifers Traum oder Klavierstück XIII*. As a piano solo. Kürten 1982.

² *Ibid.*, p. VII.

³ Cf. Mauricio Kagel: *Transición II*. For piano, percussion and two magnetic tapes. London 1963, pp. 10 and 9A or Cristobal Halffter: *Noche pasiva del sentido* (San Juan de la Cruz). For soprano, percussion and electronics. London 1973, no page named [foreword].

⁴ Cf. Witold Szalonek: *Proporzioni II*. For flute, violincello and grand piano (or harp). Kraków 1971, no page named [foreword].

⁵ Kagel, *Transición II*, p. 10.

do not cause a problem for the *glissando* on the strings because the player might, in such a case, vary the vertical position on the string at his discretion. All *glissandi* on the strings are chromatic. Therefore, no special method of notation needs to be introduced, but the common *glissando* notation may be used.

6.3.3 The progressive modification of the point of plucking and its notation

The technique of modifying the point of plucking can be, on the strings of a piano and the harp, executed in the same manner. The method of notation suggested in section '5.3.1 The progressive modification of the point of plucking and its notation' can hence be transferred to the piano. As shown there, the articulation may be depicted by means of the common *glissando* notation, giving the direction *glissando del mano* (*glissando* with the hand), the playing positions determined for the instrument and an optional additional (single lined) notation system. However, in the case of the piano, additional crossbeams that connect the basic braces may compromise the performance of unrestricted modifications of the point of plucking. Sometimes, the beam between the first and second basic brace may be, however, detached, e. g. on the *Steinway D-274* the crossbeam that is located over the strings $F - c\#^2/F2 - C\#5$. Moreover, the articulation may be preferably executed by the assistant because the music rest (and score) restricts the pianist, the modification of the point of plucking can be only executed on the uncovered strings (cf. 'Appendix B' for additional crossbeams and concerning the uncovered strings) and it may not be possible to reach any position on the bass strings. Therefore, it is suggested here permitting that the modification of the point of plucking may – as in the case of Stockhausen's horizontal string *glissando* – be interrupted in the case of additional crossbeams and should preferably be executed with both hands by the assistant on the uncovered strings. As shown above, 3 to 5 playing positions (*sul*

smorzatore, *quasi sul smorzatore*, *ordinario*, *sul ponticello* and *quasi sul ponticello*) can be employed, whereas on long piano models only the positions *ordinario* to *sul ponticello* may be presumably reached on the bass strings. Further, this technique cannot be adequately executed on the highest strings.

6.3.4 The vertical *glissando* on the strings with/without playing and its notation

The vertical *glissando* on the strings of a piano is strongly related to the vertical *glissando* on the harp. Hence it may be notated in the same manner and be executed by means of the fingers/hand, the fingernails or items, such as brushes, threaded rods or plectrums. However, there are differences that need to be acknowledged: as in the case of the progressive modification of the point of plucking, additional crossbeams that connect the basic braces do not permit the performance of unrestricted vertical *glissandi*, the articulation may be only adequately executed from the assistant's position and on the strings that are not covered by the bass strings (cf. 'Appendix B'). Moreover, the assistant may not be able to reach any position on the bass strings. The length of a piano string reaches from the short or long bridge (at the assistant's position) to the felt strip (at the pianist's position). However, the assistant may only slide up to the dampers. As in the case of the harp, the vertical *glissando* may preferably be executed on the lower strings and cannot be executed on the highest strings.

As shown in section '5.3.3 The vertical *glissando* with/without plucking', the position on the string is depicted by means of the common harmonic notation whilst starting from the neck. Because the shape of the neck and the rear end of the frame correlate, and it is easier for an assistant standing at the rear of a piano to execute vertical sliding motions (as well as to stop harmonics), it is reasonable to use a method of depiction that is, firstly, related to the harmonic notation of the harp and, secondly, corresponds to the

assistant's perspective. In order to execute the sliding motions in an exact manner, the assistant may have to mark the nodes with chalk¹. Moreover, it is suggested here permitting that the vertical *glissando* may – as in the case of the modification of the point of plucking – be interrupted in the case of additional crossbeams and should preferably be executed with both hands. Additionally, it is assumed that the player may only slide up to 1/2 of the string length on the bass strings of concert grand pianos and 4/5 of the string length on the other uncovered strings, including all bass strings on short models. The point at 4/5 of the string length corresponds to the *sul smorzatore* position. The most unlimited vertical motions may be executed on short models without additional crossbeams, such as the *Boston GP-156, -163 (PE) and -178*, the *Steinway O-180 and S-155* as well as the *Yamaha C3*. However, such models are rather rare. When it is unsure whether the articulation may be perfectly executed, an alternative option could be presented. Sliding motions on the partially covered strings are not recommended here being employed because it is hard to predict whether they may be executed or not on the piano models available for performance. Further, it needs to be taken into account that the number of uncovered bass or middle range strings varies from model to model. To give an example, the highest bass strings on one model could be, on another model, covered middle range strings. Likewise, the highest of the uncovered middle range strings on one model could be, on another model, partially covered middle range strings. Hence the number of strings that need to be considered as partially covered may be higher than the actual number of the model used in a performance and is dependent on the suggested models.

The notation of this technique can be achieved in the same way as in the plucked instruments' figure 267. When the assistant performs a vertical *glissando* on the strings,

¹ Cf. Sevsay, Handbuch, p. 263.

he may also either pluck the strings or execute the motion without any *pizzicato*. As this technique is the most common articulation when playing on the strings, it will be treated in the same way as on the harp. Thus when the player is supposed to execute a vertical *glissando* without plucking, the direction *non pizzicato* is suggested here being employed. Additionally, the assistant may slide on strings that are played by the pianist. As in the case of simultaneously plucking the string, a harmonic *glissando* evolves when sliding over the nodes.

In figure 291 an assistant is supposed to execute two motions on the $c^1/C4$ -string. It is in the beginning plucked and vibrates – due to playing *non lasciar vibrare* – for the duration of a minim (for the subsequent muting of plucked strings cf. section ‘6. 5 Muting and its notation’). During this time a *glissando* with the finger is executed, starting on the second partial (octave; notated in the same way as on the harp). The finger is then moved to the $g^1/G4$ (third partial) for the duration of a quaver, to position $c^{\#3}/C^{\#6}$ for the duration of another quaver and finally $f^1/F4$ (fourth partial) also for the duration of a quaver. The next motion can be described in the same way. However, this time the string is not plucked (*non pizzicato*) and the player employs the fingernail. Moreover, the harmonic notation for the second partial is replaced by means of a diamond-shaped note head on position $c^2/C5$. When the string is not plucked, no sound is produced when the finger rests. Therefore, the *glissando* ends when the $e^1/E4$ is reached and a demisemiquaver is applied pro forma. This transferred *glissando* motion may be only executed without any problems on the *Bechstein C 234* and *D 282* or similar models. However, on the other models listed in ‘Appendix B’ (disregarding those examined by *Vaes*), the $c^1/C4$ string is partially covered by the bass strings and/or an additional crossbeam is located in this area of the strings. Alternatively, the vertical

glissando may also be depicted by means of two systems (one for the plucking/basic string and one for the *glissando*).

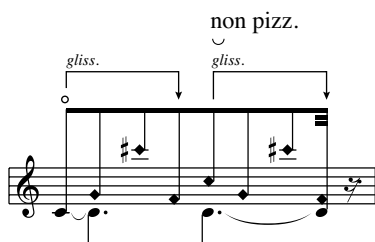

Fig. 291 The vertical *glissando* with/without plucking.

The dynamic level is low when executing a vertical *glissando* without playing, but may be increased by using items (for the depiction of items cf. section ‘6. 1. 2 The *pizzicato* on the strings and its notation’). The dynamic level of such vertical slides should be limited when using items that could harm the material of the string. However, in *Sinfonia N. 6* Henze, for instance, requests to stroke the strings of a piano with the highest dynamic level using a brush with natural bristles and with the dynamic level *forte* using an iron brush¹. Moreover, Holliger requests in *Partita*² a vertical *glissando* with the dynamic level *forte* using a plectrum, and Szalonek makes use of a vertical *glissando* using a threaded rod in *Proporzioni II* while the highest dynamic level is, in this case, *pianissimo*³. Further, cluster slides may be notated by means of utilising the paradigm presented in figure 301.

6. 4 Extended modes of attack

Most extended modes of attack involve the interior of the piano. As in the case of the harp, a *toccato* – which refers to the string being touched after the attack – may be

¹ Cf. Henze, *Sinfonia N. 6*, pp. 68 and 126.

² Cf. Heinz Holliger: *Partita*. For piano. Mainz et al. 2003, p. 25.

³ Cf. Szalonek, *Proporzioni II*, p. 1.

performed. Further, the **utilisation of beaters** is another extended mode of attack while on the piano **extended *battuto* techniques** may also be executed.

6. 4. 1 The *toccato* and its notation

The *toccato* technique may be employed in the same way as on the harp. Hence it can be notated similarly when utilised on the piano strings. As shown in section ‘5. 4. 1 The *toccato* and its notation’, the articulation is simply requested by giving the direction *toccato*, depicting the string that is touched by common note heads and determining the playing position. Any item or beater can be used for this technique (cf. section ‘6. 1. 2 The *pizzicato* on the strings and its notation’ for the depiction of items and section ‘6. 4. 2 The utilisation of beaters and its notation’ for the depiction of beaters). When the string has been played and still vibrates, a sound effect occurs. Moreover, another *toccato* articulation, referred to as the *buzz-pizzicato*, is discussed in section ‘6. 6. 3 Exact muting stops/harmonics and their notation’ because it is related to the depiction of muting stops.

6. 4. 2 The utilisation of beaters and its notation

The utilisation of beaters on the strings of a piano strongly resembles the utilisation of beaters on the harp. Therefore, it may be requested in the same way. As mentioned in section ‘5. 4. 3 The utilisation of beaters and its notation’, beaters may on the harp be employed in the same way as on mallet instruments. Hence when beating the strings of a piano or executing *glissandi* with an agent of attack, a beater symbol can be used in combination with a depiction of the strings that are struck or involved in the *glissando*. Additionally, the playing position needs to be described. Moreover, most extended piano techniques and several extended beaters attacks, such as plucking the string with

the beater (especially on the single wired strings), modifying the point of impact, executing a vertical *glissando* with/without plucking, striking with the handle of a beater or entire length of a stick, rubbing motions with beaters on the body as well as the stop attack can be performed. They may be depicted by adding a beater symbol to the paradigms presented in figure 255 (extended *pizzicato*), 260 (modification of the point of plucking) and 267 (vertical *glissando*) in the chapter on plucked instruments. Moreover, the methods of notation presented in figure 194 (common and extended attacks), 219, 220 (rubbing motions) and 251 (stop attack) in the chapter on percussion instruments can also be transferred to the piano. Moreover, strokes on the body and frame of the instrument are discussed in section ‘6. 8 Percussive effects and their notation’.

Another extended harp technique is referred to as the **extended trill with items** and described by inserting an item in between two strings and repetitively hitting these. It may be, in the case of the piano, preferably executed between the single wired strings from the assistant’s position, but when using a thin item, such as a plectrum, also on the other uncovered strings by the pianist or assistant. The number of low bass strings that are single wired varies depending on the piano model. However, as apparent from the Vaes listing, at least eight bass strings (${}_{2A} - {}_1E/A0 - EI$) are, on the examined pianos, single wired whilst ten models actually have eight single wired strings. Moreover, three models have nine single wired strings (up to ${}_1F/FI$), three models ten single wired strings (up to ${}_1F\#/F\#I$) and one model eleven single wired strings (up to ${}_1G/GI$)¹. Hence the extended trill with items may be preferably executed between the eight lowest strings. The method of notation for the harp may be, in this case, also transferred to the piano, which means that a sketch of the action should be employed and the two strings that are played be depicted (cf. figure 273 in the chapter on plucked instruments).

¹ Cf. Vaes, *Extended*, pp. 1032-1048.

Further, the playing position may be, on the piano, modified during the extended trill with items (cf. section ‘6. 3. 3 The progressive modification of the point of plucking’).

6. 4. 3 Extended *battuto* techniques and their notation

As shown in section ‘5. 4. 4 Extended *battuto* techniques and their notation’, the *battuto* with items is, in the case of the harp, suggested being depicted by giving the direction *battuto*, employing common note heads in a pitch-based notation system as well presenting a symbol of the item or requesting it by means of a direction. The position on the string is depicted by means of the common playing positions and can be modified (see above). As this technique may be employed in a similar manner on the strings of a piano, it may be notated in the same way.

6. 5 Muting and its notation

The muting of piano strings works in the same way as on the harp whilst the muting position also has an impact on the produced sound. This technique is, however, discussed in section ‘6. 6. 3 Exact muting stops/harmonics and their notation’. Moreover, when all strings of a piano are supposed to be muted, the instrument can be prepared, e. g. by attaching adhesive tape to the strings. Such actions are discussed in section ‘6. 9 Preparing the instrument and its notation’. Besides these preparations, there is one muting variant on the piano. It may be described as muting the string with the palm whilst simultaneously plucking it with the same hand. This technique may be preferably executed by the assistant. This constant muffling resembles the **application of mutes**. It can be notated in the same way as on plucked instruments and hence by giving the direction with/without mute (hand) or *con/senza sordino (mano)*. The impact of this

muting technique is, however, only extensive in the case of released dampers. When playing in this way, the dynamic level is always low.

Further, **hand muffling** may be also executed in the same way as on the harp when playing on the strings of a piano: in the case of the assistant playing *non lasciar vibrare* and the damper pedal (or, in certain cases, the *sostenuto* pedal) being depressed or playing on the undamped strings, the tones are muted according to the depicted duration. However, when the assistant is playing *lasciar vibrare* and the dampers are released, the hand muffling needs to be specifically notated. In such a case, the muting sign (\oplus) is used. The muting sign may be employed solely in order to request that all tones played by one hand are muted simultaneously. When the tones are, however, supposed to be muted in a sequence, the muting sign needs to be used in combination with a depiction of the string that is muted (cf. figure 277 and 278 in the chapter on plucked instruments as well as figure 248 and 249 in the chapter on percussion instruments).

6.6 Extended stopping techniques

There are three extended stopping techniques on the piano. The first one – **clusters** – is discussed here with regard to playing at the keys. Moreover, another augmented articulation, which may be regarded as nearly conventional, is referred to as **depressing the keys silently**. Further, the third technique – **exact muting stops/harmonics** – may be only executed on the strings of the piano. This sub-section implies the description of the *buzz-pizzicato*.

6.6.1 Clusters

Clusters are specifically discussed here because they can be, on the keyboard of a piano, produced in different ways: either by depressing the white, black (diatonic clusters) or

the black and white keys (chromatic cluster). Moreover, the keys may also be depressed or released in a sequence. These two techniques are referred to here as the additive and subtractive cluster *glissando*. This is because, in the case of the additive cluster *glissando*, the pianist performs a *glissando* motion on the keys, but does not release the keys after depressing them while, in the case of the subtractive cluster *glissando*, a previously depressed cluster is successively released.

6. 6. 1. 1 Previous methods of notation

There are various ways of notating clusters. In *Vestiges*¹ Cowell, for instance, simply connects the highest and lowest tone of the cluster by a line and requests the two variants of diatonic clusters by placing either the accidental flat (cluster on the white keys) or sharp (cluster on the black keys) above the notes:

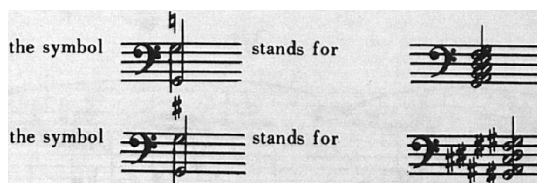

Fig. 292 Cowell, *Vestiges*, p. 3.

Moreover, when no additional accidental is used, the pianist is supposed to perform a chromatic cluster. Cowell uses two variants of notation for these kinds of clusters:

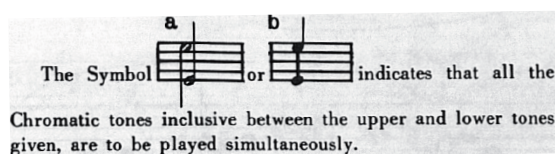

Fig. 293 Cowell, *Vestiges*, p. 3.

¹ Henry Cowell: *Vestiges*. In: Henry Cowell: *The piano music of Henry Cowell*. Volume two. New York and London 1982, pp. 3-6.

Sevsay and Stone also suggest using this approach. However, they recommend additionally depicting the highest and lowest tone of the diatonic cluster on the black keys (as well as of the chromatic cluster, in the case of the highest or lowest tone being a black key) by means of common accidentals (placed in front of the cluster note)¹. Moreover, Cage, in *In the name of the holocaust*², employs the two variants of diatonic clusters. They are requested by means of a squared cluster note and – as in the case of Cowell’s approach – placing accidentals above or beneath the note. In figure 294 Cage requests two diatonic crotchet clusters in combination. They range from presumably $F\#/F\#2$ to $a\#/A\#3$ or $c\#/C\#4$ on the black keys and an undetermined low pitch (presumably ${}_1E/E1$ or ${}_1F/F1$) to $A/A2$ on the white keys (the lower system is in bass clef).



Fig. 294 Cage, *Holocaust*, p. 29.

Further, the subtractive cluster *glissando* is utilised by Kagel in *Anagrama*. As apparent from figure 295, a chromatic cluster ranging from $C/C2$ to $B/B\flat2$ is released to $B/B\flat2$ for the duration of a dotted quaver. Subsequently, another cluster is released in a successive manner. Moreover, Kagel notates additive cluster *glissandi* similarly in *Heterophonie* by flipping the shape of the note head vertically³.

¹ Cf. Sevsay, *Handbuch*, pp. 255f. and Stone, *Notation*, p. 259.

² John Cage: *In the name of the holocaust*. Music for the dance by Merce Cunningham. In: John Cage: *Prepared piano music*. Volume 1. 1940-47. New York et al. 1960, pp. 25-29.

³ Cf. Kagel, *Heterophonie*, p. IX.



Fig. 295 Kagel, Anagrama, p. 6.

6. 6. 1. 2 Discussion

When employing the approach by Cowell (cf. figure 292 and 293), the three variants of clusters may be depicted in a simple and exact manner. However, it becomes even more exact and comprehensible when accidentals are placed in front of the highest/lowest tone if needed. Moreover, Cowell's method is more exact than that of Cage because, as apparent from figure 294, Cage does not determine the outer boundaries of the cluster in an exact manner. Concerning the shape of the notes involved in cluster chords, Cage's approach is, however, preferred. This is because cluster chords are, for instance, in the case of string instruments, most commonly notated by means of squared cluster notes¹ and there is no need to introduce another method of notation for the piano. Consequently, microtonal clusters may be requested by placing a microtonal symbol above or beneath the note and determining the outer boundaries of the chord. In the case of the piano, they can be produced by previously retuning it, but are more common in compositions that involve large string and/or wind ensembles.

Concerning Kagel's approach towards the notation of the subtractive and additive cluster *glissandi*, it may be said that this method clearly determines what kind of action the pianist is supposed to perform. It could be, however, augmented by depicting the cluster chord in the described manner. Moreover, since the pianist, as mentioned, executes a *glissando* motion on the keys, it is preferred here to request this articulation in the same way as all other *glissando* articulations. Thus in the case of the subtractive

¹ Cf. Sevsay, Handbuch, pp. 84f.

cluster *glissando*, the starting point (a cluster) and endpoint (a single tone) of the *glissando* would have to be determined and be connected by an arrow. This method could also be employed in the case of the additive cluster *glissando* as well as when the action starts/ends on a cluster or normal chord.

6. 6. 1. 3 Suggestion for the notation of clusters

Clusters are hence suggested being notated by means of squared cluster notes and placing accidentals above or beneath the note (diatonic clusters) or not placing any accidental above or beneath the note (chromatic clusters) as well as by determining the highest/lowest note of the chord. In figure 296 the pianist is supposed to execute four clusters in the order of a diatonic cluster $a - c^2/A3 - C5$ on the white keys, a diatonic cluster $e^b1 - f\#2/Eb4 - F\#5$ on the black keys, a chromatic cluster $a - c^2/A3 - C5$ as well as two diatonic clusters $e^b1 - f\#2/Eb4 - F\#5$ (on the black keys) and $a - c^2/A3 - C5$ (on the white keys) simultaneously. The duration of each cluster chord is a crotchet. When minims or semibreves are supposed to be utilised, the cluster note needs to be white.

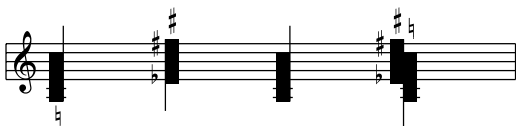

Fig. 296 Diatonic and chromatic clusters.

When playing clusters on the strings of the piano – for instance, by hitting the string with a long item (cf. section ‘6. 4. 3 Extended battuto techniques and their notation’) – they are always chromatic. Hence the method of notation without any additional accidentals can be employed¹.

¹ This method of notation can be also used when only one type of cluster may be produced and even when this cluster is not chromatic (which may be the case on the harp).

Further, additive/subtractive cluster *glissandi* are depicted here by means of the *glissando* notation used in this work. As apparent from figure 297, the player is supposed to execute three *glissandi* of this kind. Initially, he is required to play a subtractive cluster *glissando* from the diatonic cluster $a - h^2/A3 - B5$ to $h^2/B5$ for the duration of a crotchet. The endpoint of the *glissando* is then further depressed for the duration of a quaver. Subsequently, the pianist is supposed to execute an additive cluster *glissando* from $a/A3$ to the chromatic cluster $a - h^2/A3 - B5$. Hence the additive *glissando* itself is also chromatic. Finally, he plays an additive cluster *glissando* from the diatonic cluster $a^b - b^1/A^b3 - B^b4$ to the diatonic cluster $a^b - a^b2/A^b3 - A^b5$. Moreover, the endpoint and starting point of the *glissando* may also be a normal chord, and a common *glissando* from a lower/higher to a higher/lower cluster chord – containing the same amount of diatonic or chromatic notes¹ – may be notated in the same way. Further, the conventional *glissando* notation could (with difficulties) alternatively be restored in the case of these *glissandi*.

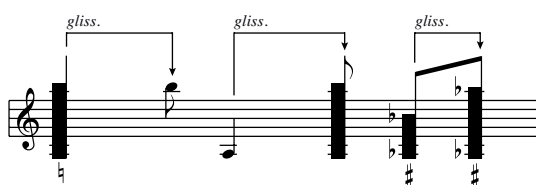

Fig. 297 Additive and subtractive *glissandi*.

6. 6. 2 Depressing the keys silently and its notation

The technique of depressing the keys silently was discovered by Schönberg. He has used the so-called piano *flageolet* in his song *Am Strande*² for the first time³. By means

¹ Cf. Salvatore Sciarrino: *Sonatina*. For violin and grand piano. Milan 1975, no page named [foreword] and p. 7.

² Arnold Schönberg; *Two songs for voice and piano*. I. Gedenken. II. Am Strande. Los Angeles 1966.

³ Peter Roggenkamp: *Schriftbild und Interpretation in neuer Klaviermusik* [Type face and interpretation in new piano music]. Vienna 1996, p. 22.

of this articulation harmonics can be produced. They occur when lower tones than the silently depressed ones are played: when, for instance, a semiquaver $c/C3$ is played and simultaneously its first three overtones $c^1/C4$, $g^1/G4$ and $c^2/C5$ are depressed silently for the duration of a semibreve, only these overtones linger after releasing the $c/C3$. The notation of this technique may be regarded as nearly conventional. Most composers depict this technique in the same way as Schönberg in *Drei Klavierstücke*¹ and hence by means of diamond-shaped notes²:

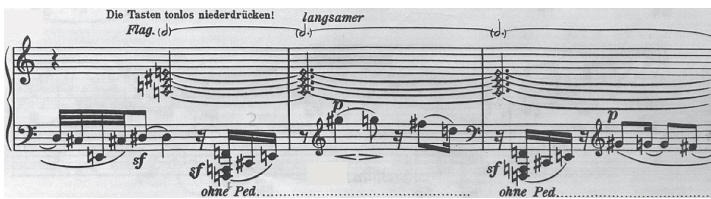

Fig. 298 Schoenberg, *Drei Klavierstücke*, p. 3.

Further, this method of notation tallies with the conventional notation of harmonics because diamond-shaped notes are, for example, also used for the notation of artificial harmonics and certain natural harmonics on string instruments. However, it is not necessary to explain that this playing technique results in harmonics being produced. This is because when the pianist follows the instructions, it is the automatic result. Therefore, Schönberg's additional direction *Flageolett* and the note in brackets do not have to be employed.

Further, cluster chords may also be depressed silently. Lachenmann requests this technique in „... *zwei Gefühle* ...“, *Musik mit Leonardo* by connecting the lowest and highest tone of the ‘harmonic’ cluster by means of a single line³, whereas Stockhausen,

¹ Arnold Schönberg: *Drei Klavierstücke* [Three piano pieces]. Los Angeles 1910.

² Cf. Roggenkamp, *Schriftbild*, p. 23, Boulez, *Improvisation II*, p. 5, Salvatore Sciarrino: *I Sonata*. For grand piano. Milan 1977. In: *Cinque sonate*. For grand piano. Milan 1997, pp. 1-54, here: p. 3, Karlheinz Stockhausen. *Klavierstück V*. London 1965, no page named [foreword] and György Ligeti: *Etudes pour piano*. Premier livre. Mainz et al. 1986, p. 20.

³ Cf. Helmut Lachenmann, *Gefühle*, no page named [foreword].

in *Kontakte*, connects the notes by two lines¹, and Messiaen, in *Des canyons aux étoiles...*², places the line aside the notes³. However, in order to depict silently depressed cluster chords in accordance with normal cluster chords, a ‘harmonic’ cluster note – which consists of a number of transposed diamond-shaped notes – is suggested here being used. Diatonic clusters can then be requested by means of accidentals placed above or beneath the note and chromatic clusters by employing no additional accidental above or beneath the note (cf. the previous section). As can be seen in figure 299, the pianist is supposed to depress four ‘harmonic’ clusters in the order of a diatonic cluster $a - c^2/A3 - C5$ on the white keys, a diatonic cluster $e^b1 - f\#2/E^b4 - F\#5$ on the black keys, a chromatic cluster $a - c^2/A3 - C5$ as well as two diatonic clusters $e^b1 - f\#2/E^b4 - F\#5$ (on the black keys) and $a - c^2/A3 - C5$ (on the white keys) simultaneously.

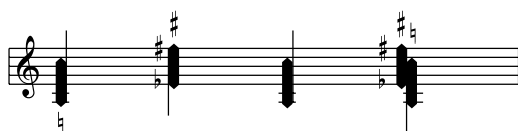

Fig. 299 Silently depressed diatonic and chromatic clusters.

Moreover, additive and subtractive *glissandi* may also be played ‘silently’. In order to depict this articulation, for instance, the notes in figure 297 need to be simply replaced by diamond-shaped notes and clusters.

6. 6. 3 Exact muting stops/harmonics and their notation

Exact muting stops may be, on the strings of a piano, executed in the same way as on the harp. They are performed by fingering an off-node position with the same pressure

¹ Cf. Stockhausen, *Kontakte*, p. 7.

² Olivier Messiaen: *Des canyons aux étoiles...* Troisième partie. For piano solo, horn, xyloimba, glockenspiel and orchestra. Paris 1978.

³ Cf. *ibid.*, p. 310.

as harmonics. When the string is then played (at the keyboard, *pizzicato* etc.), a muted tone can be perceived. This technique may be preferably executed by the assistant. Owing to the similar nature of the harp and the piano, the method of notation employed for plucked instruments is transferred to the piano. Hence exact muting stops are requested by utilising diamond-shaped notes that depict an off-node position, starting from the assistant's position (cf. section '6. 3. 4 The vertical *glissando* on the strings with/with-out playing and its notation'). As mentioned, on the strings of a piano muting stops up to approximately $\frac{4}{5}$ of the string length on the uncovered strings of all models may normally be fingered, whereas only $\frac{1}{2}$ of the string length may be reached on the bass strings of concert grand pianos. Additional crossbeams that connect the basic braces do not have a big impact on the technique because the player may reach positions under-neath or behind these crossbeams. However, this technique may be, in its full extent, only performed on the uncovered strings (cf. 'Appendix B'). Moreover, only a very limited number of muting stops may be played on the highest strings. When fingering the nodes and the string is played, harmonics evolve. They can be depicted by means of the conventional method of notation for harmonics. In this case, it needs to be, however, taken into account that, for instance, the fifth node of the sixth partial (double octave and fifth) cannot be fingered, the second partial is notated in the same way as on the harp and only a very limited number of harmonics may be produced on the highest strings.

In figure 300 the pianist is supposed to play on the keyboard while the assistant simultaneously fingers muting stops or harmonics. The mutual impact of the pianist's and assistant's actions is expressed by the additional two-headed arrow between the notation systems. The pianist plays four crotchets $c^1/C4$. However, each time another sound is produced because the assistant fingers the position $g^1/G4$ (third partial), the

second partial (octave; notated in the same way as on the harp), mutes the string on position $f^{\#1}/F^{\#4}$ and finally fingers the position f^1/F^4 (fourth partial) on the c^1/C^4 -string (also cf. the vertical *glissando* in figure 291 as well as figure 279 in the chapter on plucked instruments). In order to facilitate the performance, the assistant may, as mentioned, have to mark the nodes with chalk.

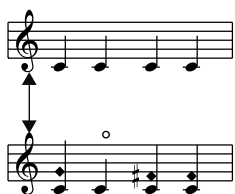

Fig. 300 Exact muting stops/harmonics and playing on the keyboard.

Muting stops or harmonics may also be executed by means of items. As mentioned in section ‘6. 4. 3 Extended battuto techniques and their notation’, the utilisation of items is either requested by a direction or by presenting a symbol for the item. Thus the notation of muting stops or harmonics executed with items may be achieved by depicting the position on the string and the item that is used. In the case of stopping clusters with a long item, the method of notation for exact muting stops/harmonics needs to be augmented to cluster chords. Hence either a normal cluster chord that depicts the involved strings and/or a normal cluster chord with a small circle above it (in order to request certain harmonic clusters) or a normal cluster chord in combination with a ‘harmonic’ cluster chord (which, as mentioned, consists of a number of transposed diamond-shaped notes, as used for the notation of exact muting stops) needs to be employed. In figure 301 **exact cluster muting stops/harmonic clusters** are requested. They are both executed by means of a threaded rod on the (chromatic) string cluster $c^1 - c^2/C^4 - C^5$ for the duration of a minim. The assistant is in the example supposed to attach the item on the tritone position and the first node. The muting position needs to be the same for each

string. Otherwise, the appearance of the score would become unclear. When the pianist simultaneously plays all or a number of the strings involved in the muted/harmonic cluster, at first muted tones and then the second partial of these tones can be perceived. Additionally, a clanking noise or buzzing evolves because the string repetitively hits the rod when the pianist plays one or more tones of the muted/harmonic cluster. This effect varies according to the material of the utilised item. Further, the additional direction *non battuto* is given in order to prevent the assistant from hitting the strings (cf. figure 280 in the chapter on plucked instruments).



Fig. 301 Exact cluster muting stops/harmonic clusters.

Moreover, when moving an item, such as the threaded rod, vertically on the string, the method of notation for the vertical *glissando* (cf. section ‘6. 3. 3 The vertical *glissando* on the strings with/without playing and its notation’) needs to be extended by the method used for the depiction of exact cluster muting stops/harmonic clusters (while harmonic clusters need to be only employed in the case of the pianist or assistant simultaneously playing one of the tones involved in the cluster).

Further, the **buzz-pizzicato** is executed in the same way as on plucked and string instruments. Therefore, the method of notation presented in the plucked instruments’ figure 281 (or the string instruments’ figure 89) may be transferred to the piano. As mentioned, the *buzz-pizzicato* may be produced in three ways: 1. By slightly touching the lingering string with the fingernail after a *pizzicato*/the respective key is played. 2. By slightly touching the lingering string with the fingertip after a *pizzicato*/the respec-

tive key is played. 3. By slightly touching the string with the fingernail during the performance of a *pizzicato*/whilst the respective key is played). In the case of variants 1 and 2, a *pizzicato*-sound is followed by a buzzing, whereas, in the case of variant 3, a *pizzicato*-sound and buzzing blend. The method of notation can be derived from the described figures (and figure 300 in the case of variant 3).

6. 6. 4 ‘Half harmonic’ stops and their notation

As mentioned in section ‘5. 7. 2 Half harmonic stops and their notation’, half harmonic stops are a string instrument and guitar technique, which cannot be employed on the harp. However, it may be used in a similar way on the piano since the pressure applied to the string may – in comparison to exact muting stops/harmonics – be increased. The result is that the string bends a little. When, for instance, the pianist plays a string that is muted with increased pressure, the sound produced by the hammers hitting the string and a hardly perceptible colouring can be heard. Since this technique is strongly related to the performance of half harmonic stops on string instruments and the guitar – because the pressure is, on these instruments in comparison to the normal harmonic fingering, also increased –, it can be notated by transferring the paradigm presented in section ‘2. 6. 1 Half harmonic stops and their notation’. Hence a normal note head that depicts the involved string, a diamond-shaped note that determines the muting position and a complementary white and black diamond-shaped symbol placed above the note can be used to request this articulation (cf. the previous section as well as figure 85 in the chapter on string instruments). Additionally, clusters may also be muted in this way and hence the paradigm presented in figure 301 (exact cluster muting stop) be complemented by the described symbol. In the case of applying these ‘half harmonic’ stops on nodes, diamond-shaped notes should always be employed to depict the position on the

string because no harmonics are produced, but the string is – due to the increased pressure – muted.

6.7 Pedal effects

There are two pedal effects. One is referred to as **extended pedal changes** while the other can be described as **pedal strokes**.

6.7.1 Extended pedal changes

The gradual change of the damper pedal position resembles the pedal-*glissando* on the harp (cf. section ‘5.3.6 The pedal-*glissando*’). However in the case of the piano, the change of the pedal position does not result in raising or lowering the pitch, but a gradual release or depression of the dampers. Additionally, the pedal may constantly be ‘half’ depressed¹. Stockhausen explains that, in this case, the right pedal is depressed “just so far down that the duration of the attack and a soft continuation of the note are audible after releasing the key”². Moreover, the pedal is depressed halfway for notes in the middle register, one-third for the low register, two-thirds for the high register and completely for the highest register³ (whilst no dampers are, as mentioned, applied on grand pianos either from *f*³/*F*⁶, *g*³/*G*⁶ or *g*³/*G*⁶ on).

6.7.1.1 Previous methods of notation

In most cases, a gradual depression or release of the damper pedal is requested by means of the conventional pedal symbol and an additional line. Moreover, a gradual

¹ Cf. Sevsay, Handbuch, p. 264.

² Karlheinz Stockhausen: Klavierstück VI. London 1965, no page named [foreword].

³ Ibid., no page named [foreword].

change to the ‘half’ pedal position is depicted by adding the direction 1/2. Kagel, in *Passé composé*¹, makes use of this method of notation. Additionally, rapid releases and re-depressions are in this piece also requested by means of the additional line.

In the example presented in figure 302, the pianist is supposed to depress the pedal, release and re-depress it quickly, then release the pedal quickly and change to the ‘half’ pedal, release the pedal quickly and change to the completely depressed pedal, release and re-depress the pedal quickly etc. The duration of each action is depicted by means of the piano’s notation system.



Fig. 302 Kagel, *Passé*, p. 26.

However, in *Klavierstück VI* Stockhausen does not make use of the conventional method of notation for the depression of the pedal, but requests to use the damper pedal by means of the letter ‘P’ whilst the pedal position is related to the vertical position of an additional line. In figure 303 the pedal is initially ‘half’ depressed, then gradually released and again ‘half’ depressed. Shortly (i. e. a quaver ‘grace rest’) after attacking the *C/C2* the pedal position is changed to completely depressed and then quickly to ‘half’ depressed. Subsequently, the pedal is gradually released, after a rest again ‘half’ depressed and released. This action is followed by a quick change between the completely depressed pedal and the ‘half’ pedal etc.

¹ Mauricio Kagel: *Passé composé*. Frankfurt/M. et al. 1996.

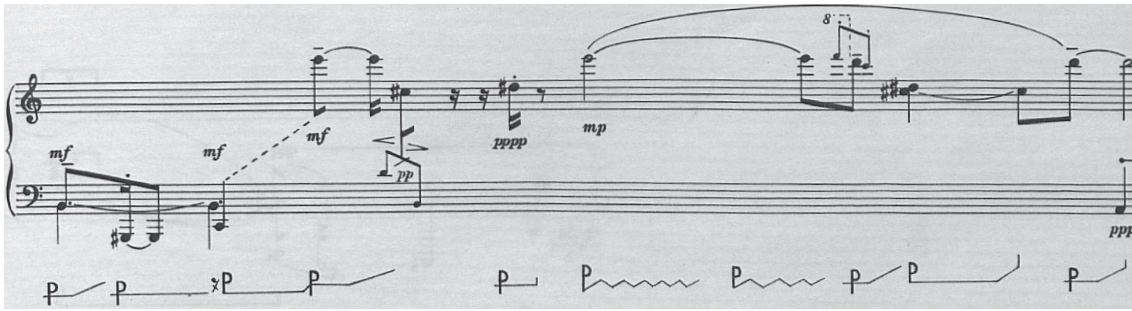

Fig. 303 Stockhausen, Klavierstück VI, p. 25.

Moreover, Sevsay suggests making use of the conventional symbol for depressing the pedal whilst the pedal position is, in this case, also related to the vertical position of an additional line. Further, a dotted line is used whenever the position is changed gradually. Additionally, bracketed notes may be used to depict the duration of the change:

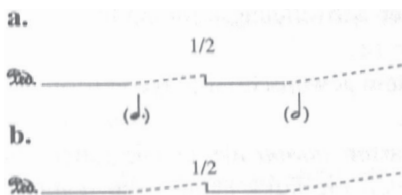

Fig. 304 Sevsay, Handbuch, p. 264.

6.7.1.2 Discussion

The normal depression of the pedal is conventionally depicted by means of the pedal symbol whilst the normal release is either depicted by means of a star or vertical line¹. These methods of notation should be, therefore, also employed in the case of a gradual depression or release of the pedal. Concerning this matter, Kagel's method of notation (cf. figure 302) can hence be preferred to that of Stockhausen (cf. figure 303). However, it is clearer to depict any gradual change to one of the three pedal positions by means of the vertical position of the additional line. Therefore, Stockhausen's and Sevsay's

¹ Sevsay, Handbuch, p. 254.

method (cf. figure 304) may be preferred in this matter. When comparing these two approaches, Sevsay suggests a clearer method because the pedal position is not only depicted by means of the line, but (as in the case of Kagel's approach) also determined by means of the direction $1/2$ and the pedal symbol. However, there is no need to employ a dotted line and the actual release of the pedal should be, as mentioned, either requested by means of a star or vertical line. Moreover, when willing to depict the duration of the gradual change in an exact way, a distinct timeline for the pedal is suggested here being used instead of the bracketed notes (cf. figure 272 in the chapter on plucked instruments).

6.7.1.3 Suggestion for the notation of extended pedal changes

Extended pedal changes are hence suggested here being notated by combining the methods of notation by Kagel, Stockhausen and Sevsay while it is preferred to request the release of the pedal by means of a star. This is because when requesting a long depression of the pedal (without gradual changes), an additional line would otherwise have to complement the notation system constantly¹ and the star is – despite being rarely used in contemporary works² – the more traditional method of notation. Further, a quick release and re-depression may be depicted in a clearer manner when additionally using a star³.

In figure 305 two alternative methods for the depiction of pedal position changes are presented. In the case of the first method, the changes are displayed by means of the piano's notation system: the pianist plays four crotchets $c^1/C4$. The pedal is in the beginning depressed, but from this point on gradually released for the duration of a

¹ Cf. Kagel, *Passé*, p. 11.

² Cf. Sevsay, *Handbuch*, p. 254.

³ Cf. *ibid.*, p. 264.

crotchet to the ‘half’ pedal position. The pedal position is then changed back to the completely depressed pedal for the duration of another crotchet and, before the fourth note is played, quickly released and re-depressed. Finally, the pedal is gradually released for the duration of a crotchet. When depicting the pedal changes by means of a distinct timeline, more complex actions may be notated: the pianist again plays four crotchets $c^1/C4$. In the beginning of the second example the pedal is ‘half’ depressed (this symbol may also be used to request a constant utilisation of the ‘half’ pedal position). Subsequently, the pedal position is in turns changed from completely depressed to ‘half’ depressed in a semiquaver rhythm. After this ‘trill-*glissando*’ the pedal remains depressed ‘halfway’ for the duration of a dotted quaver, is then released for the duration of a semiquaver and gradually depressed for the duration of a crotchet.

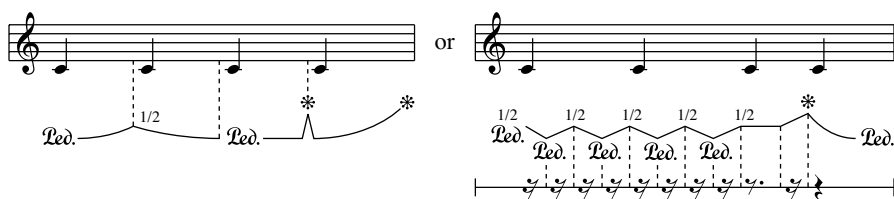

Fig. 305 Gradual pedal changes.

Further, in the case of requesting the ‘half’ pedal, the pianist needs to determine how far the pedal is depressed. Even though Stockhausen has clearly explained the execution of this technique, it is still at the pianist’s discretion how far the pedal is depressed when, for instance, notes in the low and middle register are simultaneously played. Another option would be to introduce more pedal positions, e. g. $1/3$, $1/2$ and $2/3$. Further, the production of pedal ‘noise’ may be requested in the same way as gradual pedal changes. When the pedals are moved vigorously and the strings are not played, they start to vibrate anyway. The dynamic level of the pedal noise is always very low.

6. 7. 2 Pedal strokes

When requesting pedal strokes, the pianist is supposed to hit the pedal box with the pedal itself, which results in a popping sound. This action may be executed in combination with depressing or releasing the pedal. In the case of hitting the pedal box, the strings are caused to vibrate when the pedal is not released after the violent depression. Moreover, pedal strokes may complement the articulation of silently depressing the keys (cf. section ‘6. 6. 2 Depressing the keys silently and its notation’). When the pedal is violently depressed and a number of keys at the same time silently depressed, it needs to be, however, subsequently released in order to produce the desired effect¹.

6. 7. 2. 1 Previous methods of notation

There are a number of approaches towards the notation of the pedal strokes. For instance, Delás, in *Outremer clair et foncé*², depicts this articulation by means of a special arrow pointing downwards, a (modern) pedal symbol and an additional dynamic level:

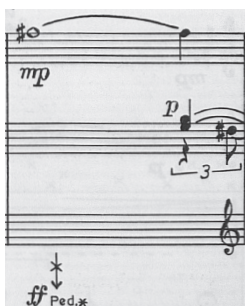

Fig. 306 Delás, *Outremer*, p. 31.

¹ Cf. *ibid.*, p. 264.

² José Luis Delás: *Outremer clair et foncé*. In: Alfons Kontarsky (ed.): *Pro musica nova. Studies for playing avant-garde music. For piano.* Cologne 1972, pp. 30-33.

Another method is suggested by Sevsay. He recommends depicting pedal strokes by means of additional x-shaped note heads in a single lined notation system with no clef:

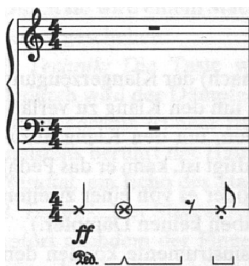

Fig. 307 Sevsay, Handbuch, p. 265.

Moreover, Stone suggests using diamond-shaped notes instead of x-shaped ones in a single lined notation system¹.

6.7.2.2 Discussion

In this work percussive effects, such as strokes on the body of an instrument, are depicted by means of a symbol for the sound producer, a sketch of the instrument and x-shaped note heads in a single lined notation system with no clef (cf. section '2.7.1 Strokes on the body and their notation'). However, in the case of pedal strokes, the action itself is already adequately described by means of the symbol for depressing or releasing the pedal. This symbol merely needs to be complemented by a note, symbol or direction that requests to additionally hit the pedal box when using the pedal. Since x-shaped note heads are normally used to depict percussive effects, they could also be utilised in this case. However, another additional notation system could cause an unclear appearance of the score when used in combination with gradual pedal changes (cf. figure 305). But if x-shaped note heads were used in the system that depicts the duration of the gradual pedal changes, both articulations could be simultaneously employed

¹ Cf. Stone, Notation, p. 271.

without causing confusion. Therefore, requesting pedal strokes by means of x-shaped note heads (cf. figure 307) is preferred here to utilising an additional symbol (cf. figure 306). Moreover, Stone’s diamond-shaped notes should not be used for the notation of pedal strokes because they are, in this work, only utilised to request harmonics or related articulations (cf., for instance, section ‘6. 6. 3 Exact muting stops/harmonics and their notation’).

6. 7. 2. 3 Suggestion for the notation of pedal strokes

Pedal strokes are hence suggested being notated by means of x-shaped note heads in a single lined notation system with no clef. In figure 308 the pedal changes from the previous example are augmented by making the player strike the pedal box when depressing the pedal completely for the first, third and fourth time as well as when releasing the pedal. The dynamic level of the first three strokes is *forte* and of the last one *piano*.

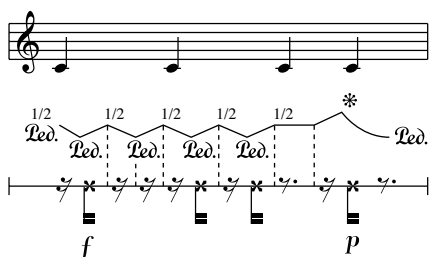

Fig. 308 Pedal changes and strokes.

6. 8 Percussive effects and their notation

Percussive effects may be produced on the piano’s body (or other parts) as well as on its strings. The hand or items may be used to strike the frame, soundboard, lid etc. of the instrument. As shown in section ‘2. 7. 1 Strokes on the body and their notation’, strokes on the body of an instrument may be depicted by means of a drawing of the instrument’s body – which enables the determination of the point of impact – in

combination with a drawing of the player's hand. When items are supposed to be used, a symbol replaces the drawing of the hand (cf., for instance, section '4. 1. 1 Special agents of attack and its notation'). **Strokes on the body** of a piano can hence be notated similarly by means of a drawing, such as the one presented in figure 309. As in the case of the other instruments, only a section should be, however, displayed in the score. Moreover, the drawing is related here to the assistant's position because strokes on the body may preferably be executed by this player. When the pianist is supposed to perform suchlike actions, the drawing may be flipped horizontally in order to adapt it to his perspective. In the case of using a piano with more than three crossbeams, the sketch needs to be either changed or the player be advised to transfer the strokes to a different model at his own discretion. Since it is impossible to predict the exact shape of the frame or length of the piano, the drawing is always approximate and only able to exactly depict the material (frame, crossbeams = metal, soundboard = wood) or part (crossbeam, frame, soundboard) and approximate position that is hit. Further, strokes on the lid can be requested by presenting a drawing of the lid. Strokes from underneath can be notated similarly to strokes on the front whilst it may be outlined that the bottom side is supposed to be hit by colouring the drawing black (cf. figure 206 in the chapter on percussion instruments).

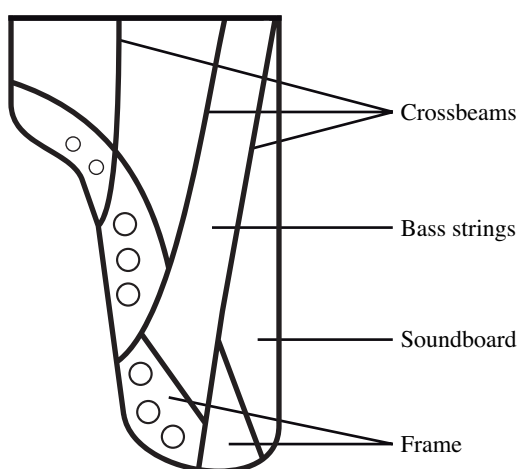

Fig. 309 The interior of a grand piano.

Moreover, the pianist may be requested to strike the keyboard lid or the wooden strip at the edge of the keyboard. In this case, another drawing needs to be employed. In figure 310 suchlike strokes are performed. They are executed in the order of – with the knuckles on the left wooden strip – with the side of the fist on the lid (middle) – with the palm on the lid (right side) – with the index, middle and ring finger on the lid (left to the middle) – with the tip of the thumb, index and middle finger as well as with the tip and fingernail of the index finger on the lid (left side). All actions are separated by quaver rests (also cf. figure 92 to 94 in the chapter on string instruments). When single fingers are supposed to be used in fast succession, the order can be, as mentioned, additionally depicted as on the piano, e. g. 4, 3, 1, 4, 0, 5.

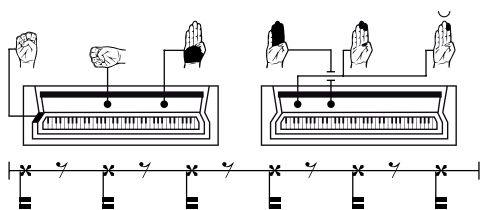

Fig. 310 Strokes on the keyboard lid and wooden strip.

Further, another percussive effect may be produced by **slamming the keyboard lid**. Cage has often used this effect. For instance, in *Music of Changes III*¹ it is notated by means of an additional single lined notation system. A normal note head and the direction slam keyboard lid request to close the lid violently whilst a bracketed diamond-shaped note and the direction open depict the opening:

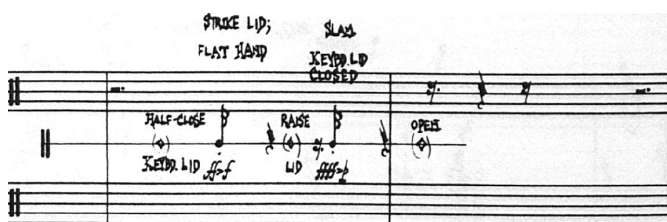

Fig. 311 Cage, Changes III, p. 62.

¹ John Cage: Music of changes III. For piano. New York et al. 1961.

However, as mentioned, percussive effects are, in this work, always notated by means of x-shaped note heads, whereas common note heads are normally related to sounds with definite pitch and diamond-shaped notes to actions that resemble the production of harmonics. Additionally, the simplest way of depicting articulations like this is to present a sketch of the action. Therefore, it is suggested here using x-shaped note heads in a single lined notation system with no clef in combination with a drawing that distinctly requests to slam or open the lid. Such a drawing is presented in figure 312. As can be seen there, the pianist is supposed to slam the keyboard lid with the dynamic level *fortissimo*, then open it after a crotchet rest with the dynamic level *pianissimo* and slam it again after a quaver rest. When the lid is supposed to be opened without producing any sound at all, no x-shaped note heads are employed here, but the player simply advised when to open the lid again. Hence the lid is in the example subsequently opened again after a crotchet rest without producing any sound. Alternatively, x-shaped note heads and the dynamic level ‘ \emptyset ’ may be, in such a case, used.

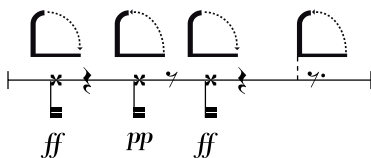

Fig. 312 Slamming and opening the keyboard lid.

As mentioned in section ‘2. 7. 2 Strokes on the strings and their notation’, **strokes on the strings** may be described as stop attacks executed with the hand. As this technique is on string, percussion, plucked and keyboard instruments executed in a similar manner, it can be notated by means of the paradigm presented in this section and hence by utilising a symbol of the hand, a muting sign (\oplus) and determining the playing position (cf. figure 96 in the chapter on string instruments). When executing dead strokes with the hand, it does not make a difference whether the strings are additionally

muted with the other hand or not because they do not vibrate subsequently to the stroke. However when using, for instance, a beater or the wood of a bow, the strings linger after the attack. Therefore, the method of notation may be augmented in order to make the player additionally finger harmonics or mute the strings (cf. figure 97 in the chapter on string instruments as well as sections ‘6. 4. 2 The utilisation of beaters and its notation’, ‘6. 5 Muting and its notation’ and ‘6. 6. 3 Exact muting stops/harmonics and their notation’).

Further, it is possible to play a *glissando without depressing the keys*¹. When doing so, only the subtle noise that evolves when the fingers slide over the keys can be perceived. This articulation is strongly related to the normal key *glissando* and the key *pizzicato*. Therefore, it is suggested here depicting it in the same way as the common key *glissando* while replacing the common with x-shaped note heads (cf. figure 290). The dynamic level of this articulation is always low, but may be increased by using the fingernails or items, such as a plectrum or pencil (cf., for instance, section ‘6. 1. 2 The *pizzicato* on the strings and its notation’ for the notation of items). The exact determination of the fingers (and fingernails) the pianist is supposed to employ can be achieved by using hand symbols, such as the ones presented in figure 310.

In figure 313 the pianist is required to perform four different *glissandi*. The first one is a diatonic *glissando* on the white keys executed with the index and middle finger whilst involving the fingernails. The *glissando* starts on the $d^1/D4$ and ends on the $a^2/A5$. The sound production ends when the last note is reached and the demisemiquaver is hence applied pro forma. The second *glissando* is diatonic and executed on the black keys with a plectrum. It starts on the $c^\sharp/C^\sharp4$ and ends on the a^b2/A^b5 . The third one is a chromatic *glissando* with the index and middle finger from $a/A3$ to $a^1/A4$ while the fourth

¹ Cf. Lachenmann, Guero, pp. 1-5.

glissando starts on the white keys ($a/A3$ to $d^1/D4$), is then executed on the white and black keys (e^b1/E^b4 to $g^1/G4$) and ends on the black keys (a^b1/A^b4 to e^b2/E^b5). In this case, the player makes use of the index, middle and ring finger whilst involving the fingernails. Moreover, *glissandi* executed with both hands (traveling the same or opposite direction) may also be notated in this manner. Alternatively, the common *glissando* notation may be restored.

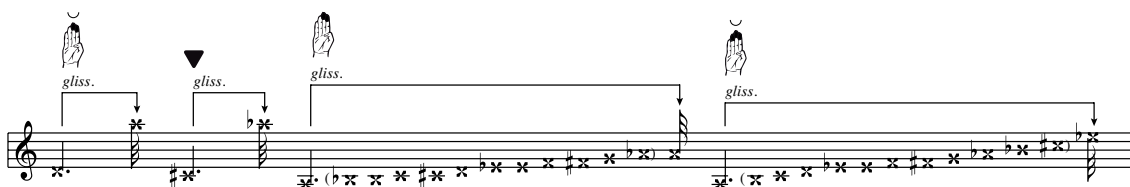

Fig. 313 The diatonic and chromatic *glissando* without depressing the keys.

Finally, another extended percussive effect is the ***glissando on the tuning pins***¹. When executing this kind of *glissando*, the pitch of the strings that are connected to the pins the player slides over is slightly perceptible. This effect can be increased by depressing the damper pedal. The technique is related to rubbing motions on the resonators of mallet instruments because, in the case of both, a percussive effect is complemented by a slightly perceptible *glissando* of the pitch. Therefore, it is suggested here notating these two articulations in the same manner. Thus the effect is depicted by presenting a drawing of the instruments (including its pins) in combination with a pitch-based notation system (cf. figure 221 in the chapter on percussion instruments). The graphic depiction of the instrument, as well as the possible extent of the *glissando* motions, is – as in the case of the strokes on the body and the *glissando* on the strings – dependent on the utilised models. Since a listing of the framework of various piano

¹ Cf. Lachenmann, *Gefühle*, no page named [foreword].

models is available (cf. ‘Appendix B’), it is, however, possible to depict *glissandi* in an exact manner and suggest models upon which these actions may be performed.

In the example presented in figure 314, the pianist is supposed to perform two *glissandi* on the tuning pins. The first one is executed for the duration of a crotchet from the pins of *a/A3* to the pins of *c²/C5* and the second one for the same duration from the pins of *a^{b1}/A^{b4}* to the pins of *a/A3*. These *glissandi* could be, for instance, performed on the *Bechstein B 212, L 167* and *M/P 192*, the *Boston GP-156 PE, GP-163, GP-163 PE* and *GP-178 PE*, the *Steinway C-227, D-274, O-180* and *S-155*, the *Wend & Lung 161* and the *Yamaha C3*. They could even be transferred to models with four crossbeams, such as the *Bechstein C 234, D 282*, the *Bösendorfer 225* etc. Further, more complex motions on the pins may be clearly notated with the help of the notation system. *Glissandi* on the tuning pins are, as *glissandi* on the strings, always chromatic.

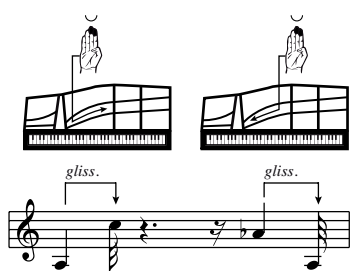

Fig. 314 *Glissandi* on the tuning pins.

Moreover, any kind of **attack on tuning pins** may be depicted in the same way as in figure 310 with the difference that a graphic depiction of the frame and pins, as well as a pitch based notation system, is utilised in lieu of a graphic depiction of the keyboard lid and a single lined notation system. The pins that are supposed to be attacked can be, in this case, also exactly determined by means of the notation system. In the case of striking the pins of a string made of two or three wires, it is, as in the case of the *pizzicato* on the strings, at the player’s discretion to determine the exact performance of

the action. Further, Lachenmann requests in *Guero pizzicati* at the tip of a tuning peg¹. However, such an attack is regarded here as a hit on a single tuning peg with the tip of the index finger.

6.9 Preparing the instrument and its notation

The piano can be, for instance, prepared by muting a number of strings with adhesive tape, as it is requested by Szalonek in *Proporzioni II*². Further, many examples of preparations can be found in Cage's works for prepared piano³. As in the case of the other instruments, there are hence numerous ways of preparing the piano. Similarly it is also, on the one hand, barely possible to list them all and subsequently develop a coherent method of depiction whilst, on the other hand, it is also not necessary to do so since most preparations are executed previously to a performance and may be simply described in the foreword to a work. Further, when preparations are supposed to be executed during a performance, they are suggested here always being notated by means of a sketch. This is because it is the simplest way of depicting these. Such a sketch should include the determination of the strings that are prepared, e. g. when only a certain range is muted with adhesive tape. When the sketch is not clear enough, it may be complemented by an explanation (cf. sections '2. 8 Preparing the instrument and its notation' and '3. 6. 2 Constructional modifications and their notation'). Nevertheless, preparations may lead to the introduction of new playing techniques that should then be notated in accordance with all other techniques presented in this work.

¹ Cf. Lachenmann, *Guero*, no page named [foreword].

² Cf. Szalonek, *Proporzioni II*, no page named [foreword].

³ Cf. Cage, *Prepared 1* and John Cage: *Prepared piano music*. Volume 2. 1940-47. New York et al. 1960.

6. 10 Summary

In this part of the work the unconventional playing techniques of the grand piano are introduced, their previous methods of notation discussed and suggestions for their notation presented. The first section focuses on extended *pizzicato* techniques, including the *pizzicato* on the keys – which refers to plucking the white keys of a piano – and the *pizzicato* on the strings. Further, the common playing positions on the strings are discussed and various *glissando* techniques examined. In the case of the piano, a common *glissando* on the keys and a *glissando* on the strings may be performed. Moreover, the point of plucking may be modified when playing on the strings and a vertical *glissando* with/without plucking be executed. The latter can be performed with the fingers/hand, the fingernails or items. The next section is then devoted to extended modes of attack. One is referred to as the *toccato* articulation and may be described as gently touching the string with the hand or an item after the attack. Moreover, beaters can be used to strike the instrument, as well as extended *battuto* techniques with any kind of item, be utilised. As in the case of the harp, the strings of a piano may be either constantly muted by means of the hand or subsequent to the attack by hand muffling. In the next section, extended stopping techniques are examined. The first one – clusters – is discussed with regard to playing at the keys because two kinds of diatonic clusters as well as a chromatic cluster may be produced. Additionally, the keys may be depressed or released in a sequence. In the next section the technique of silently depressing the keys, including silently depressed clusters, is examined. Moreover, the execution of exact muting stops and the production of harmonics on the string, including exact cluster muting stops/harmonic clusters, is discussed. Another extended stopping technique – ‘half harmonic’ stops – is then examined. When requested, the player is supposed to increase the pressure in comparison to exact muting stops/harmonics.

The next section is devoted to pedal effects. One of these effects is to gradually change the damper pedal position, another to depress the pedal ‘halfway’. Moreover, pedal strokes may be employed. When requested, the pianist is supposed to hit the pedal box with the pedal itself. Furthermore, there are various other percussive effects that may be executed on the piano, such as strokes on the body, slamming the keyboard lid or strokes on the strings (stop attacks). Additionally, a *glissando* without depressing the keys can also be performed. When required, only the subtle noise that evolves when the fingers slide over the keys can be perceived. Another extended percussive effect is referred to as the *glissando* on the tuning pins. Moreover, the pins may also be attacked by means of the hand, beaters or items. Further, the final section focuses on the preparation of the piano and portrays some of the preparations that may result in new playing techniques being created.

7. PRACTICAL EXAMPLE I – KLANGGRUPPEN

In this chapter the application of some of the methods of notation for the unconventional playing techniques of string instruments is explained by means of a work called *Klanggruppen*^{1/2} for violincello alone. Because it is only four pages long, the piece can be completely reproduced here and all utilised unconventional playing techniques be explained. By presenting the full score, an insight into how the playing techniques may shape the form of a composition and how unconventional techniques may be introduced is provided. The work was composed in 2011 after the major work on the chapter on string instruments had ended. A recording of this work and the full score (including the introduction) can be found in ‘Appendix C’. Additionally, another recording and the score of a piece for solo string instrument that was composed before the thesis was written and then revised by applying the new developments, can also be found in the appendix. It is called *Tatsachen in zwei Sätzen*^{3/4} for violin alone. This work can be, as mentioned in the introduction, regarded as the origin of this thesis and was subject to several major revisions. The recording was, however, made before these (also cf. the conclusion).

7.1 Part A

As expressed by its title, each movement of the composition inter alia comprises a particular number of sound groups (and hence playing techniques) that guarantee its homogeneous character and distinction from every other movement. The production of harmonic-*glissandi*, the simultaneous utilisation of the bow-*glissando* as well as the

¹ Sound groups.

² Premiered in August 2012, Laeishalle/Hamburg, cellist: Saerom Park Foucher (Ensemble Resonanz).

³ Facts in two movements.

⁴ Premiered in August 2010 at the DESY institute/Hamburg, violinist: Eugene Nakamura.

gettato and *tremolo* are the main characteristic elements employed in part A. As apparent from figure 315, each unconventional method of notation is introduced by a footnote or additional explanation in brackets. Footnotes are preferred here to a foreword or appendix that explains each unknown symbol. This is because when rehearsing the piece, the player does not have to constantly look up the meaning of the methods of notation in the foreword/appendix because each unconventional method is complemented by a brief explanation at the first occurrence. Moreover, the work is more accessible when it is not necessary to study the foreword/appendix before being able to grasp the intentions of the composer, but the explanations are part of the score. This is especially important when numerous unconventional playing techniques are employed and the explanations hence become very extensive.

The piece starts with a *gettato* and a harmonic-*glissando* on the G-string. The *glissando* notation is explained in the footnote. This is because the ordinary *glissando* is not used here in order to achieve a greater clearness and enable the depiction of *glissando* motions that do not involve changes in pitch (see above). Besides the common *flageolets*, the cellist is also required to produce the highest possible harmonic on the A-string (cf. section '2. 4. 1 The highest possible tone and its notation'). After two bars a bow-*glissando* (cf. section '2. 2. 2 The bow-*glissando*') on the common bowing positions is additionally executed (which can be regarded as an example of a *glissando* that does not involve changes in pitch). The duration of the complementary bow-*glissandi* is depicted here by means of another notation system placed above the ordinary one. In order to shorten the utilised directions, abbreviations of the bowing positions are applied. In sequence 2, bar 7 the player is then supposed to slide with the bow from the *sul ponticello* position to the fingerboard position $b - f^l/B\flat 3 - F4$ for the duration of a dotted minim. From this point on the bow-*glissando* is used in an

augmented manner and in the final sequence of the first movement solely executed on fingerboard positions.

Further, in sequence 3, bar 4 the cellist produces the third partial on the C-string (its first node $G/G2$ is notated by a diamond-shaped note head) and fingers the position $f/F3$ on the G-string with harmonic pressure. Because no node is touched on the G-string, an exact muting stop (cf. section ‘2. 6. 2 Exact muting stops and their notation’) is depicted here. At the same time, the interval that describes the bowing position on the fingerboard is not a fifth, but a minor seventh. Hence the bow is, as explained in the score, not aligned at right angles to the string. Exact muting stops and the *saltando* articulation – which is for the first time applied in sequence 3, bar 6 – are merely introduced in the first movement. They then become two of the main playing techniques in part B.

Teil A | Part A

Tempo ♩ = 27

[Dieses System zeigt im Folgenden Bogenpositionen auf dem Griffbrett an, hier dient es nur dazu die Dauer der vertikalen Bogenbewegung zu bestimmen. – As can be seen below, this system is used to depict the positions of the bow on the fingerboard. In this case, it is employed in order to determine the duration of the bow's vertical motion.]

gliss. Glissando; befinden sich mehrere Noten unter dem Pfeil, wird durchgängig glissandierte. – Glissando; when several notes are underneath the arrow, a continuous glissando is performed.

¹ Bogen-Glissando: Es versteht sich als eine vertikale Bewegung (auf und ab) des Bogens auf der Saite und wird durch die Anweisung *glissando d'arco* gefordert. – Bow-glissando: It can be understood as a vertical motion (up and down) of the bow on the string and is supposed to be performed when the direction *glissando d'arco* is given.

♫ Höchstmögliches Flageolett – Highest possible harmonic

² s. p. = *sul ponticello* ³ s. t. = *sul tasto*



[Hier gleitet der Bogen auf das Griffbrett. Die Position auf der Seite wird durch die eckigen Notenköpfe beschrieben. – Here, the bow slides on the fingerboard. The position on the string is depicted by the diamond-shaped note heads]



[Wenn das Intervall ≠ eine Quinte, liegt der Bogen *nicht* im rechten Winkel zur Seite auf. – When the interval ≠ a fifth, the bow is *not* aligned at right angles to the string.]

[Wenn *kein* Knotenpunkt angegeben ist, soll die Saite an angegebener Stelle gedämpft werden. – When *no* node is depicted, the string is supposed to be muted at the designated point.]

Geräuschvoll blättern – Turn the page in a noisy way

⁴ salt. = saltando: Dichter Praller der geschlagenen Bogens; keine horizontale Bewegung. Der Bogen wird auf die Saite geworfen und gepresst. Dense shake of the bow after striking the string; no horizontal motion. The bow is thrown and pressed onto the string.

Fig. 315 Klanggruppen, p. 1.

7.2 Part B

The main characteristic elements in part B of *Klanggruppen* are the *col legno saltando* and *balzando*, half harmonic and exact muting stops, bowing *sul ponticello*, the *Bartók pizzicato* as well as the *col legno tratto* and *battuto*. Occasionally, the ordinary *pizzicato* is also used. In the second movement the cellist is actually supposed to only finger off-node positions whilst applying either harmonic or half harmonic pressure (cf. section ‘2. 6. 1 Half harmonic stops and their notation’). Moreover, the veiled, almost immaterial and hardly perceptible colouring of the dominating string sound (half harmonics) or rough whistle sound with indefinite pitch (exact muting stops) is complemented by the character of the respective utilised bowing technique. Two unconventional techniques are employed in this part of the composition, the *col legno saltando* and *balzando* (cf. section ‘2. 3. 3 The *saltando*, *balzando* and *toccato* and its notation’). Further, the technique that needs to be employed in order to prevent the *saltando* from dying out in sequence 3, bar 2/3 is additionally explained. The *pizzicato* is, in the second movement, occasionally utilised in order to establish a reference to the upcoming final movement where it is one of the main playing techniques.

As can be seen in figure 316, no directions concerning the strings are given here, but the string is supposed to be selected by the player. However, in most cases, an off-node position is depicted, no matter which string is chosen by the cellist. Only the sixth partial (node: minor third) is occasionally produced. However, it may be solely perceived in its full extent in the case of the *B/B2 pizzicato* in sequence 3, bar 1 (when choosing the G-string) and the *arco f/F3* in sequence 3, bar 5 (when choosing the D-string) because otherwise the pitch would anyway be veiled by either the half harmonic articulation (sequence 1, bar 1/2), the percussive *col legno balzando* (sequence 1, bar 6) or the *Bartók pizzicato* (sequence 4, bar 4).

Teil B | Part B

Tempo ♩ = 42

◆ Halbflageolet-Griff: Höherer Fingerdruck als beim Flageolet und niedriger als bei normalen Griffen. –
 Half harmonic stop: Higher finger pressure than when stopping harmonics and lower than in case of fingering normal tones.

⁵ c. l. = col legno

⁶ balz. = balzando: Ein ruhiges »Aufspringenlassen« des durch sein Eigengewicht auf der Saite zurückfedernden Bogens; keine horizontale Bewegung. –
 A gentle »bouncing« of the bow on the string by its own weight; no horizontal motion.

[saltando perpetuo: Die Phase des schnellsten Auf- und Zurückspringens wird am Stillstand gehindert, indem durch minimales, höchst sensibles Dagenhalten des Bogens in Abstrichrichtung – also durch einen winzigen horizontalen Reibungswiderstand – der Bogen immer wieder in die Höhe zurückgeworfen wird. – The phase of the most rapid bouncing up and down is prevented from dying out when the bow is tossed upwards again and again by a minimal and highly sensitive push in a down-bow motion – nothing more than a minute horizontal frictional resistance.]

Während der Stille mit größter Körperspannung in der Spielposition verharren, die zu Beginn von Teil C eingenommen wird. –

During the silence, remain with greatest body tension in the playing position that is adopted in the beginning of part C.

Fig. 316 Klanggruppen, p. 2.

7.3 Part C

The left-hand *pizzicato*, the left-hand *battuto* on the fingerboard, the rolling bow, the *col legno* bow-*glissando* without bowing (vertical shift without any horizontal motion), the *tremolo*, harmonics and the *vibrato* are the main characteristic elements in the third movement. For the rolling bow (cf. section ‘2. 3. 4 The rolling bow and its notation’) six speed levels are, as apparent from figure 317, introduced. By doing so, the manner of performance may be further varied. From sequence 1, bar 4 onwards the cellist simultaneously executes either a left-hand *battuto* on the fingerboard (cf. section ‘2. 3. 2 Extended *battuto* and *tratto* techniques and their notation’) or a left-hand *pizzicato* (cf. section ‘2. 1 Extended *pizzicato* techniques and their notation’). These articulations are either performed on strings that are also attacked by means of the rolling bow articulation and hence muted (e. g. the first *battuto* and *pizzicato* on the G-string in sequence 1, bar 4) or on open strings and may thus further vibrate (e. g. the *pizzicato* on the open A-string in sequence 1, bar 4). The left-hand *pizzicato* is not complemented here by a determination of the fingerboard position since, firstly, a third notation system would have to be, in some cases, introduced and cause an unclear appearance of the score whilst, secondly, the articulation is often directly preceded by a left-hand *battuto* (or another articulation) and the fingerboard position is, in such a case, anyway clear.

When the rolling bow articulation has ended in sequence 2, bar 4, the player produces harmonics, which are, for instance, in sequence 2, bar 7/sequence 3, bar 1 compromised by an additional *vibrato* motion of the fingers. Three intensity degrees are used here for the *vibrato*: *poco vibrato*, the normal *vibrato* and *molto vibrato*. Moreover, the cellist is also required to further execute left-hand *pizzicati* and *battuti*. For instance, the *pizzicato* B/B \flat 2 is, however, in sequence 3, bar 1 complemented by a *col legno* bow-*glissando* from the *sul ponticello* position to the fingerboard position f \sharp 1/F \sharp 4 for the

duration of a quaver, which results in a *glissando* of the pitch. Moreover, as can be seen in figure 318, a buzz-effect is occasionally produced by touching the vibrating string with the bow's wood (e. g. sequence 1, bar 1) and – as in part B – *col legno battuti* requested. The piece ends with the *vibrato* production of a the second partial on the G-string (*tremolo sul ponticello*), the *vibrato* production of the second partial on the D- and G-string and finally a harmonic-*vibrato* without bowing (cf. section '2. 2. 1 The harmonic-*glissando* without bowing and its notation') on the D- and G-string. The final articulation is depicted by means of diamond-shaped note heads because, even though the same positions are fingered, no harmonics are produced when not utilising the bow.

Teil C | Part C

Tempo ♩ = 35

⁷ rotolato = Rollbewegung: Der Bogen liegt dabei wie üblich auf den Saiten und die Bogenstange wird in das Haar gepresst. Durch das gegenseitige Aufeinanderscheuern von Bogenhaaren, Saite und Bogenstange infolge der Drehbewegung der aufgedrückten Bogenstange entsteht ein trocken prasselndes Knirschen. Für diese Drehbewegung werden sechs Geschwindigkeitsstufen festgelegt, von Tempo 1/6 (langsam) bis Tempo 6/6 (schnell). – The rolling bow: The bow is as normal attached to the string and the wood of the bow pressed into the hair of the bow. As a result of the rolling motion of the pressed wood of the bow, the combined friction of the bow hair, the string and the wood of the bow produces a dry crackling grinding. For this rolling motion six speed levels are determined, ranging from tempo 1/6 (slow) to tempo 6/6 (fast).

⁸ battuto (mano sinistra) = Battuto mit der linken Hand: Die Saiten werden ohne Bogenstrich gegriffen. Der Finger muss dabei fest auf die Saite schlagen und sie auf das Griffbrett drücken. Diese Artikulation wird manchmal als Tapping bezeichnet. – Left-hand battuto: Fingering the strings without bowing. The finger needs to strongly hit the string and push it against the fingerboard. This articulation is sometimes referred to as tapping.

⁹ pizzicato (mano sinistra) = Pizzicato mit der linken Hand – Left-hand pizzicato

¹⁰ non tratto = Ohne horizontalen Strich – No horizontal bowing

¹¹ m. s. = mano sinistra

Fig. 317 Klanggruppen, p. 3.

solamente sul A *gliss. d'arco* sul D *gliss. d'arco* (tocc.)

col legno non tratto

sul D e G arco sul tasto sempre: (mano sinistra)

pizz. (m. s.) sul G c. l. tocc.¹² c. l. batt. batt. (m. s.) molto poco v. sul D batt. sul A pizz. sul D sul A e D c. l. tratto

ff mp ff

¹² col legno toccato = Die Saiten leicht mit dem Holz berühren. Ein (Summ-)Effekt tritt auf, da die Saiten noch vibrieren. – Touch the string gently with the bow's wood. A (buzz-)effect occurs because the string still vibrates.



gliss. d'arco col legno non tratto c. l. tocc. *gliss. d'arco* col legno non tratto

sul G arco sul pont. sul D e G arco sul pont. senza arco¹³

pizz. (m. s.) sul G sul D (mano sinistra) batt. pizz. sul C arco sul tasto molto vibr. pizz. (mano sinistra) sul C poco vibr. molto poco v. p pppp

¹³ senza arco = Ohne den Bogen zu benutzen (nur die linke Hand) – Without utilising the bow (only the left hand)

Fig. 318 Klanggruppen, p. 4.

7.4 Summary

In this part of the work the application of some of the unconventional playing techniques of string instruments is explained by means of the composition *Klanggruppen* for violincello alone. Each of the three movements inter alia comprises a particular number of playing techniques that guarantee its homogeneous character and distinction from every other movement. The main characteristic elements in part A of the work are the production of harmonic-*glissandi*, the simultaneous utilisation of the bow-*glissando*, the *gettato* and *tremolo*. In part B the *col legno saltando* and *balzando*, half harmonic and exact muting stops, bowing *sul ponticello*, the *Bartók pizzicato* as well as the *col legno tratto* and *battuto* are the major techniques while the ordinary *pizzicato* is occasionally used. Finally, in part C the left-hand *pizzicato*, the left-hand *battuto* on the fingerboard, the rolling bow, the *col legno* bow-*glissando* without bowing (vertical shift without any horizontal motion), the *tremolo*, harmonics and the *vibrato* are the principal elements.

8. PRACTICAL EXAMPLE II – PIECES NOS. 2 TO 4, 7 AND 8

During the writing process several pieces that make use of the developed methods of notation have been composed and older instrumental works been revised by replacing earlier methods of depiction with the new developments. Altogether seven compositions (pieces no. 1-4 and 6-8) imply the methods of notation presented in the thesis. In this chapter the application of some of the unconventional playing techniques is explained by means of five of these works. They are grouped here by the instrumental categories wind instruments, percussion instruments, plucked instruments and keyboard instruments. All examples are taken from the works *Entgleisungen*¹ for flute, B \flat clarinet, piano, percussion, violin and violincello, *Zu vier Händen – Interventionen für Konzertflügel*² for piano and assistance, *Ausführung über den Materialbegriff*³ for B \flat clarinet, mezzo-soprano, contrabass and electronics, *Filterspiel – Music for conferences*⁴ for 4 percussionists, 4 assistants, 4 interpreter's booths and electronics and *Three songs* for two guitarists. The pieces *Filterspiel – Music for conferences* and *Three songs* make use of the thesis' developments, whereas the other compositions were revised after the writing of the thesis. Selected examples from these works are presented in this chapter in order to explain how the developments may be implemented in musical works. The scores of all works are provided in 'Appendix C'. Further, an estimate concerning the applicability of the developed methods of notation, which is based on the experiences gathered during the composition and revision processes, is then given in the conclusion.

¹ Derailments.

² For four hands – Interventions for grand piano.

³ Treatise on the material.

⁴ *Filterspiel* is German for 'filterplay', derived from the word *Kreuzspiel*, German for 'crossplay', which is the title of one of Stockhausen's earliest works.

required to play the fingerings in this order and start from the beginning after fingering 2 has been played for the second time (cf. figure 114 in the chapter on wind instruments).

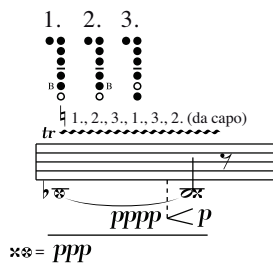

Fig. 320 Materialbegriff, p. 2.

Finally, the articulation is also applied in combination with multiphonics (while these are requested by notating the main tone(s) of the chord – here by means of a microtonal symbol and only one tone –, the fingering and the addition ‘m’). In figure 321 the player is supposed to perform a multiphonic *bisbigliando*. Three fingerings are depicted while the order of the fingerings is again additionally determined¹.

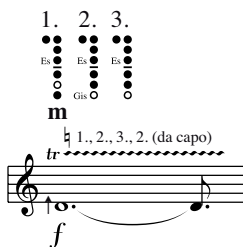

Fig. 321 Materialbegriff, p. 30.

Further, one extended tongue technique is utilised in no. 4: the flutter tongue. In this work the two flutter tongue types – the [r]- and [R]-variant – are requested. For instance, in figure 322 it can be seen that the player is supposed to play a (written) *g/G3* and use the [R]-flutter tongue² (cf. section ‘3. 2. 1 The flutter tongue and its notation’).

¹ See *ibid.*, pp. 30-122 for multiphonic fingerings.

² For the [r]-variant see, for example, *Materialbegriff*, p. 10.

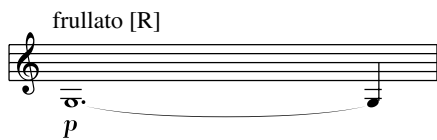

Fig. 322 Materialbegriff, p. 9.

Moreover, in nos. 2 and 4 extended embouchure techniques are utilised. In *Entgleisungen* the clarinettist is supposed to play the clarinet with trumpet embouchure. As explained in section ‘3. 3. 1 The trumpet embouchure’, this technique can be, however, only performed on the clarinet when playing without mouthpiece. Therefore, the direction *senza imboccatura* (cf. section ‘3. 6. 1 Detaching the headjoint/mouthpiece/reed/bocal and its notation’) is employed in combination with the direction *alla tromba*:

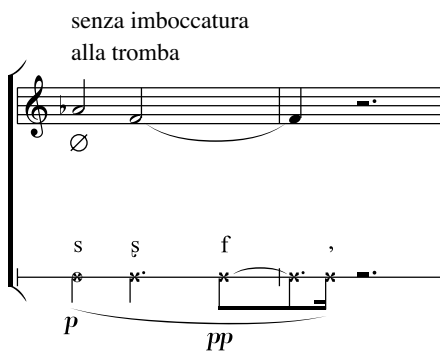

Fig. 323 Entgleisungen, p. 12.

As apparent from figure 323, the trumpet embouchure is additionally combined with the speaking and playing technique (cf. section ‘3. 5. 2 The speaking and playing technique and its notation’). In the example the clarinettist is supposed to articulate the fricatives [s] (minim), [ṣ] (dotted crotchet) and [f] (crotchet and semiquaver) while the last one ends with the ejective [ʹ] (semiquaver). Simultaneously, a (written) minim $ab^1/Ab4$ and a (written) dotted minim $f^1/F4$ is fingered. In the case of this articulation, it needs to be considered that the pitches that may be only produced by overblowing cannot be used because no blowing is employed. If the clarinettist attacks normally, the

written compass of the B \flat clarinet ranges from ‘d/D3’ to ‘a \flat 1/A \flat 4’ (when disregarding microtones)¹.

In no. 2 the flautist also makes use of the speaking and playing technique. As apparent from figure 324, the articulation is complemented by key clicks. In the case of the flute, the tones $e^2/E5$ to $c^{\#3}/C\#6$ are produced by overblowing² and hence cannot be used in combination with the speaking and playing technique.

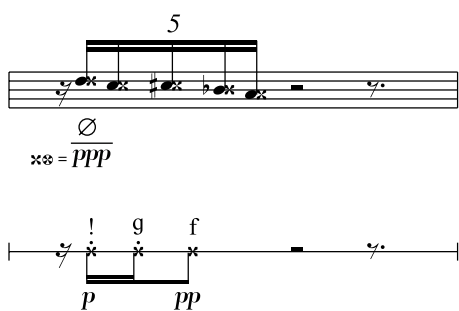

Fig. 324 Entgleisungen, p. 12.

Further, in nos. 2 and 4 the teeth embouchure is utilised. However, it is handled in different ways: in *Entgleisungen* the resulting pitch is supposed to be determined by the player while only the fingering is depicted by common note heads³. By contrast, in *Ausführung über den Materialbegriff* the most natural (common note head), lowest possible (triangular note head pointing downwards) and highest possible (triangular note head pointing upwards) teeth tone is requested (cf. section ‘3. 3. 3 Teeth embouchure’):



Fig. 325 Materialbegriff, p. 15.

¹ Cf. Krassnitzer, Klarinette, pp. 159-170.

² Cf. Levine and Mitropoulos-Bott, Flute, pp. 64-74.

³ Cf. Entgleisungen, p. 20.

The pitch bending technique is in no. 4 one of the main playing techniques of the clarinet. The transposition system (cf. section ‘3. 4 Pitch bending – the extended *glissando*’) is, in this work, used to depict this technique, but also the duration of the connected *de-/crescendi*. As apparent from figure 326, the player is supposed to execute a *decrecendo* from *fortissimo* to *mezzopiano* for the duration of two triplet quavers, a *crescendo* to *forte* for the duration of another triplet quaver and a subsequent *decrecendo* to *mezzoforte* for the duration of a quaver, which is followed by another *decrecendo* to *piano* for the duration of a quaver. Here four level for upward transpositions and eight levels for downward transpositions are utilised¹ because the pitch on the clarinet can be only raised slightly, but lowered by several semitones (also cf. figure 143 in the chapter on wind instruments).

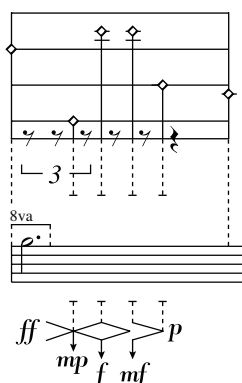

Fig. 326 Materialbegriff, p. 1.

Moreover, a special symbol, similar to the *vibrato* symbol, is used in this piece to depict fast transitions between two dynamic levels. In figure 327, for instance, the symbol is employed for the dynamic levels *mezzoforte* and *mezzopiano* while the constant *de-* and *crescendo* begins with the upper one² and ends with *mezzopiano*. A variant of notation would be to use several *de-/crescendo* symbols instead of the *vibrato* line.

¹ Cf. Materialbegriff, p. 1.

² Cf. *ibid.*, p. 1.

Additionally, the pitch bending articulation is, in the case of the (written) $a^2/A5$, not employed from the beginning of the tone production, but after the tone has been normally attacked for the duration of a minim.

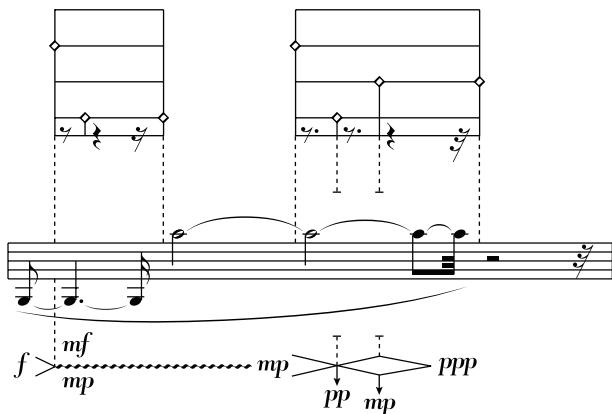

Fig. 327 Materialbegriff, p. 1.

Furthermore, the jet whistle technique is utilised in no. 2. As mentioned in section ‘3. 7. 2 The jet whistle’, it can be only performed when the embouchure hole of the flute is completely covered with the lip. Therefore, it occurs in combination with the direction *al clarinetto* (cf. section ‘3. 3. 2 The closed embouchure and its notation’):



Fig. 328 Entgleisungen, p. 17.

Finally, the subtone articulation is employed in both pieces. As mentioned in section ‘3. 11 Other extended playing techniques and their notation’, it is normally requested by means of utilising the lowest dynamic level and the additional direction subtone:



Fig. 329 Materialbegriff, p. 12.

8. 2 Percussion instruments

Percussion instruments are utilised in work no. 2 and in *Filterspiel – Music for conferences* (no. 7). The unconventional playing techniques used within these works are, as far as possible, sorted with reference to the chapter on percussion instruments.

In both pieces the percussive apparatus is extended by introducing special agents of attack. In no. 2 a sand block and a household brush are used while in no. 7 these two agents and a cardboard tube are utilised. The agents are, in both cases, depicted by means of special symbols displayed in the foreword. Additionally, it is, as apparent from figure 330, determined how the special agents are normally employed. This is because by declaring that, for instance, the entire length of the cardboard tube is always used to attack the instrument, an additional symbol that requires the player to attack with the entire length of the agent of attack can be dismissed (cf. figure 194, point 3 in the chapter on percussion instruments).

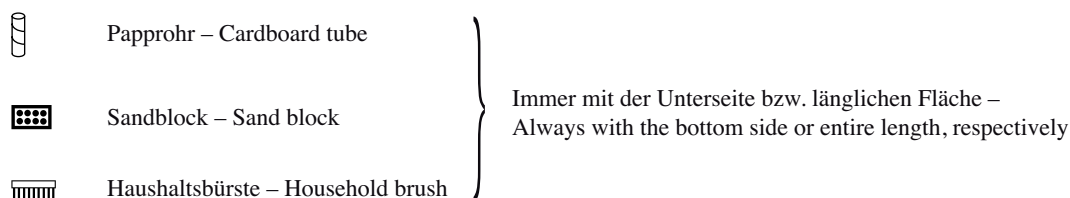

Fig. 330 *Filterspiel*, no page named [foreword].

Further, the agents of attack are used in an extended way in nos. 2 and 4. For example, in *Entgleisungen* an attack with the handle is requested (cf. section ‘4. 2. 1 The extended utilisation of the agents of attack’). As apparent from figure 331, the player is supposed to perform a repetitive ‘circular’ rubbing motion with the shaft of a wooden headed mallet¹ with tempo 5/6 (cf. figure 222 in the chapter on percussion instruments). However, this rubbing motion is special since it is executed inside a cowbell.

¹ For all beater symbols cf. the foreword of the respective work.

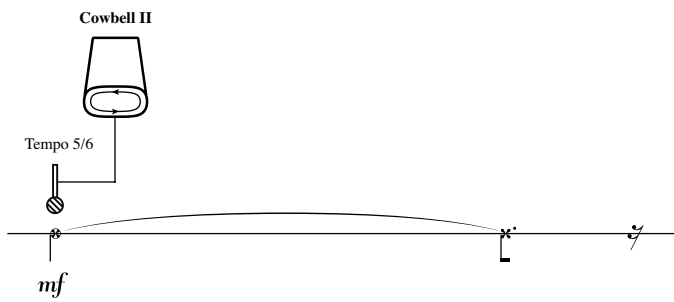

Fig. 331 Entgleisungen, p. 23.

Moreover, in no. 7 the player is required to use the entire length of a beater. In the example presented in figure 332, the percussionist is at first supposed to execute a normal stroke with a hard timpani mallet of felt on a tom-tom (TT) and, after a dotted quaver rest, use the entire length of a wooden headed drumstick to attack a bass drum (GT, as in the German *Große Trommel*, meaning bass drum). The point of impact is, as suggested in section ‘4. 2. 3 The point of impact’, determined by means of an illustration of the instrument. As can be seen in the example, one illustration is used to depict the tom-tom and bass drum. All illustrations for instruments with a similar shape have the same size in nos. 2 and 7. As mentioned, this method is less exact than the method of making the illustrations correspond to the actual size of the instrument, but it enables a simpler handling.

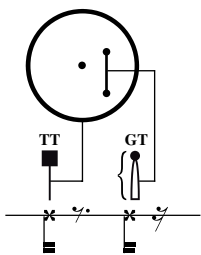

Fig. 332 Filterspiel, p. 2.

Additionally, the extended striking techniques *balzando* and *toccato* are in *Filterspiel* – *Music for conferences* used. As apparent from figure 333, the player is required to

execute a *balzando* articulation with a plastic headed drumstick on a tom-tom – and hence let the beater bounce on the head by its own weight (cf. section ‘4. 2. 2 Extended striking techniques’).

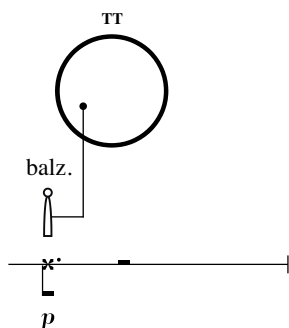

Fig. 333 Filterspiel, p. 6.

Further, the *toccato* articulation is employed in order to produce the sizzle effect on a gong. As apparent from figure 334, the player is at first supposed to strike the instrument with a gong mallet and subsequently touch the vibrating instrument with a metal stick (initially, the direction *sempre lasciar vibrare* is given¹).

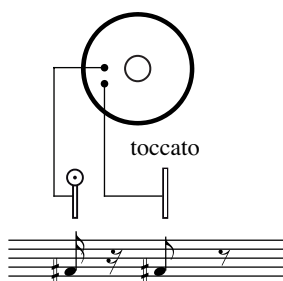

Fig. 334 Filterspiel, p. 3.

Gradual shiftings of the point of impact are also employed in no. 7. In figure 335 the percussionist is, for example, supposed to use a plastic headed drumstick and a wooden headed drumstick simultaneously (on a Chinese cymbal) and shift the point impact of the former away from his body and of the latter towards his body. At the same time, the

¹ Cf. Entgleisungen, p. 1.

dynamic level is increased from *piano* to *fortissimo* (cf. figure 204 and 208 in the chapter on percussion instruments).

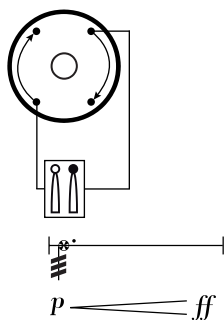

Fig. 335 Filterspiel, p. 6.

Further, shell attacks are used in both works. As apparent from figure 336, several strokes in *Entgleisungen* are executed on the shells of timpani in A, C, G and D (cf. figure 205 in the chapter on percussion instruments).

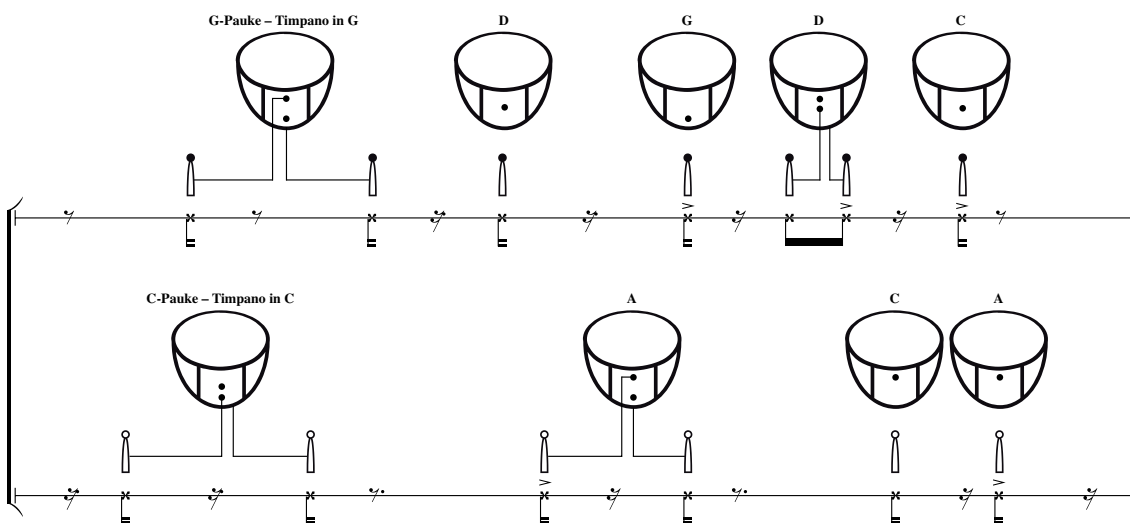

Fig. 336 Entgleisungen, p. 19.

Additionally, the point of impact is gradually shifted in the case of shell attacks. As can be seen in figure 337, the percussionist is required to execute two rolls for the duration of a semibreve and a quaver, one on the shell of a timpano and the other one on a slit gong. While doing so, the point of impact is, in the case of the timpano, shifted

downwards and, in the case of the slit gong, from the left to the right. At the same time, the dynamic level of the shell attacks is increased from *mezzoforte* to *fortissimo* and the dynamic level of the slit gong roll decreased from *fortissimo* to *mezzoforte*.

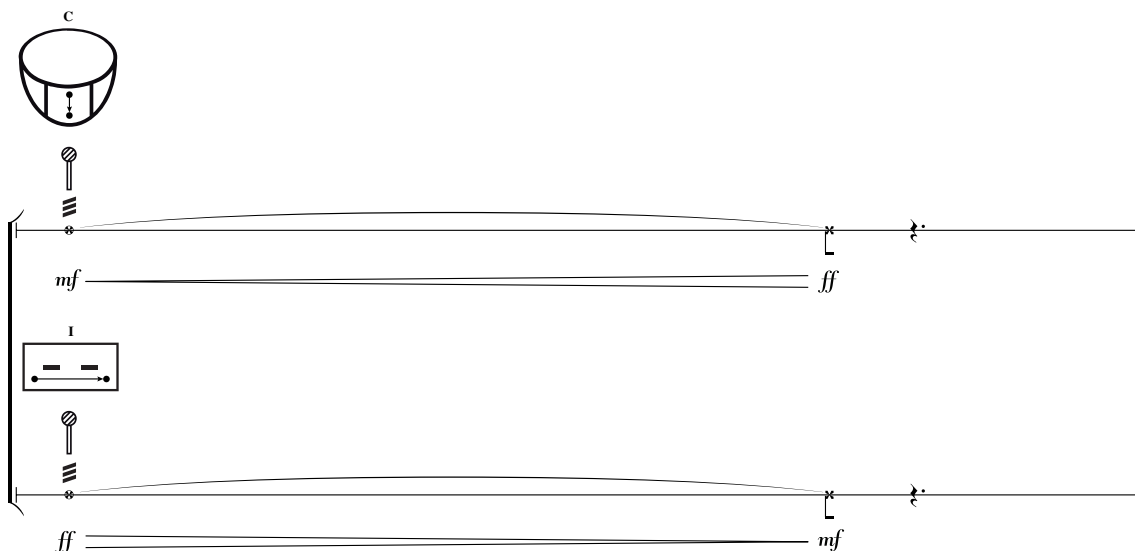

Fig. 337 Entgleisungen, p. 22.

Moreover, another extended articulation is employed in *Filterspiel – Music for conferences*. As can be seen in figure 338, the player is supposed to strike a cymbal (B, as in the German *Becken*, meaning cymbal while the Roman numeral I refers to cymbal no. 1) from underneath with the knuckles (cf. figure 206 in the chapter on percussion instruments for the attack and figure 92 and 93 in the chapter on string instruments for the utilisation of the hand as an agent of attack).

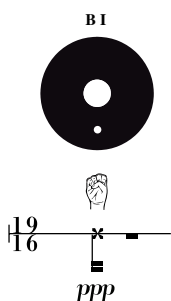

Fig. 338 Filterspiel, p. 4.

Further, two types of rim shots are employed in no. 7. The common rim shot is displayed in figure 339. As is apparent, the player is at first supposed to simultaneously execute a normal stroke with a hard timpani mallet (on the left side of a bass drum) and a stroke with the entire length of a drumstick (approximately in the centre). After a semiquaver rest the left spot is struck again with the timpani mallet, and the drumstick is used to perform a rim shot (cf. figure 209 in the chapter on percussion instruments).

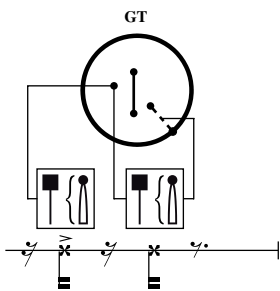

Fig. 339 Filterspiel, p. 3.

The other rim shot variant used in piece no. 7 is to hit a drumstick lying on the head and rim with another beater:

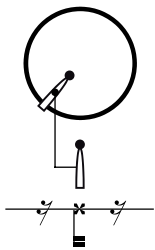

Fig. 340 Filterspiel, p. 3.

Additionally, several rubbing motions (cf. section ‘4. 2. 4 Rubbing and bowing motions’) are used in nos. 2 and 7. In the example from *Entgleisungen* presented in figure 341, the percussionist is, for instance, supposed to simultaneously execute two singular rubbing motions on both heads of a bass drum (as explained in the foreword of piece no. 2, the drum is elevated and positioned in such a way that both sides may be

attacked). The right head of the drum is stroked by a household brush while the left head is stroked by a soft bass drum mallet (cf. figure 219 in the chapter on percussion instruments).

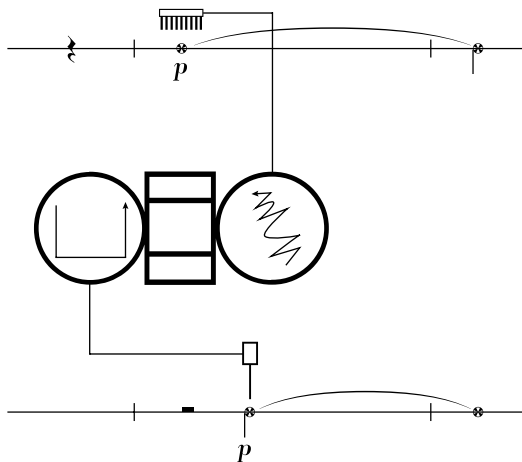

Fig. 341 Entgleisungen, p. 14.

Moreover, in no. 7 the duration of such singular rubbing motions is often determined in a more exact manner. For instance, in figure 342 the player is supposed to execute a singular motion on a djembe (DB). However, the motion is split here in two parts while the first part is executed for the duration of a crotchet and the second part for the duration of a crotchet and two semiquaver triplets.

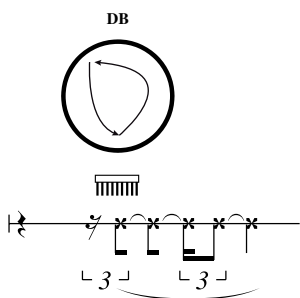

Fig. 342 Filterspiel, p. 15.

Further, even a scraping motion with the entire length of a beater is performed in piece no. 7. In order to depict it, a specific method of notation – derived from the depic-

tion of strokes with the entire length of the beater – is utilised (while the player is additionally holding a microphone in his left hand and a contact microphone is attached to the head of the bass drum):

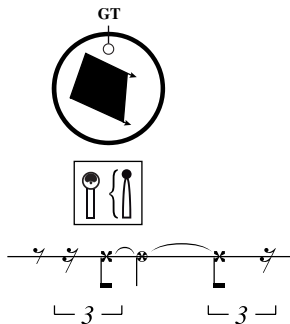

Fig. 343 Filterspiel, p. 9.

Moreover, several repetitive rubbing motions are employed in both pieces. For example, in *Entgleisungen* simultaneous repetitive rubbing motions on both heads of a bass drum are requested. The articulation on the right head is executed with a soft bass drum mallet whilst its tempo is constantly changing, whereas the action on the left head is performed with the thumb, index and middle finger whilst involving the fingernails (the utilisation of the fingernail is explained in section ‘2. 1 Extended *pizzicato* techniques and their notation’) and executed in an irregular manner (*irregolare*).

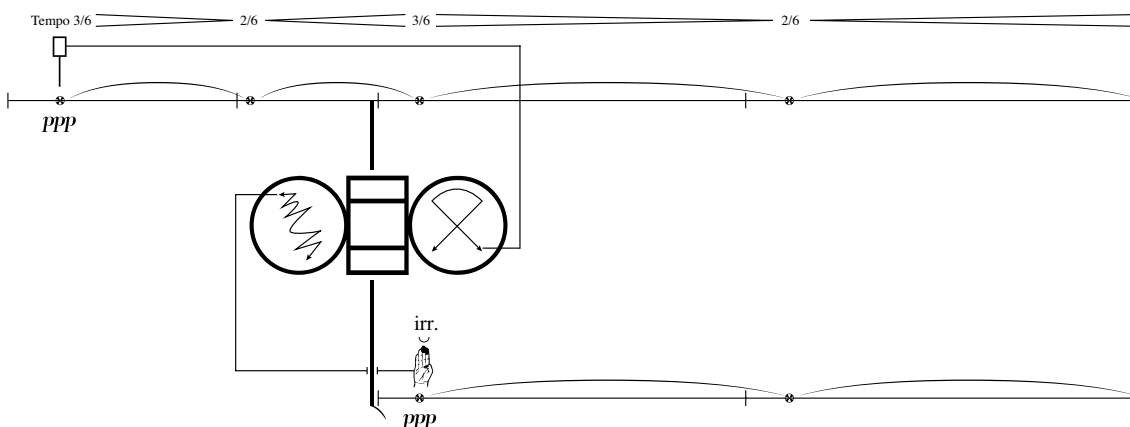

Fig. 344 Entgleisungen, p. 12.

Additionally, in no. 7 actions on a vibraphone's resonators are requested. In the example presented in figure 345, the percussionist is supposed to execute a singular rubbing motion on resonator *h/B3* (*staccato*), followed by a roll, which involves a shifting of the point of impact, on resonator *h¹/B4*. Additionally, a diatonic trill¹ and a *glissando* rubbing motion² on the resonators are requested (cf. figure 221 in the chapter on percussion instruments).

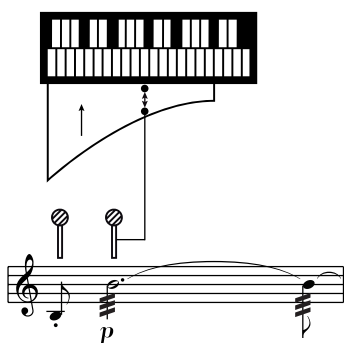

Fig. 345 Filterspiel, p. 15.

Moreover, in both works 'circular' rubbing motions are employed. Besides the action of executing a 'circular' rubbing motion inside a cowbell (see above), in no. 2 the player is required to execute a motion of this kind by means of a sand block on a tom-tom (cf. figure 222 in the chapter on percussion instruments):

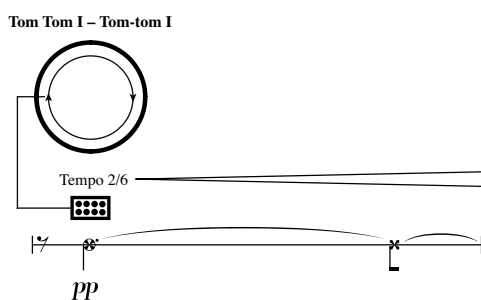

Fig. 346 Entgleisungen, p. 1.

¹ Cf. Filterspiel, p. 16.

² Cf. *ibid.*, p. 17.

Further, rubbing motions that involve the rim are also requested in *Filterspiel – Music for conferences*. As apparent from figure 347, the percussionist is, in this work, supposed to perform a singular rubbing motion with a household brush on the rim (of a gong). It is executed for the duration of a crotchet and a semiquaver triplet (*staccatissimo*) and followed by a singular rubbing motion on the surface of the instrument, performed for the duration of a crotchet and two semiquaver triplets (cf. figure 224 in the chapter on percussion instruments).

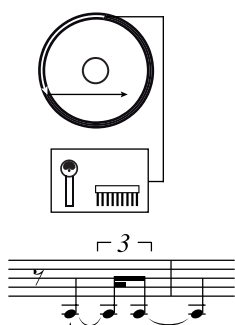

Fig. 347 *Filterspiel*, p. 12.

Additionally, bowing motions are utilised in nos. 2 and 7. For instance, in no. 7 a gong is bowed. As apparent from figure 348, the player is supposed to perform a down-bow motion, which is followed by an up-bow motion. Both motions are executed for the duration of a minim (cf. figure 225 in the chapter on percussion instruments).

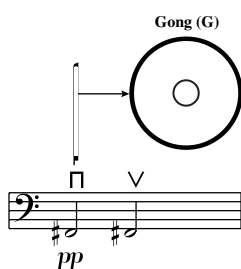

Fig. 348 *Filterspiel*, p. 1.

Further, in no. 2 a metal stick is used to execute a down-bow motion on a keyboard lid (cf. figure 310 in the chapter on keyboard instruments for the depiction of the lid):

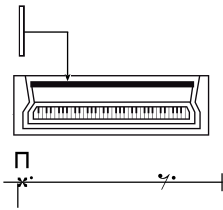

Fig. 349 Entgleisungen, p. 6.

Furthermore, in nos. 2 and 7 several articulations without agents of attack are utilised. It is, for example, in *Filterspiel – Music for conferences* requested to rub two clash cymbals against each other with tempo 2/6 (cf. figure 232 in the chapter on percussion instruments):

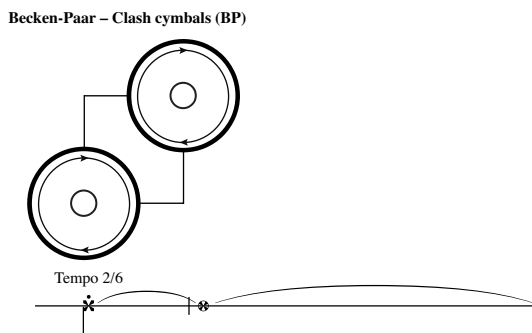

Fig. 350 Filterspiel, p. 13.

Moreover, in piece no. 2 the player is supposed to spin a djembe filled with ten marbles. As can be seen in figure 351, the tempo is changed during the spinning from 3/6 to 5/6 for the duration of a dotted crotchet and a semiquaver and then changed to 2/6 for the duration of a dotted minim (cf. figure 234 in the chapter on percussion instruments). As apparent from the foreword of the work, the djembe needs to be turned upside down and be previously filled with the marbles (cf. section ‘4. 5 Preparing the instrument and its notation’).

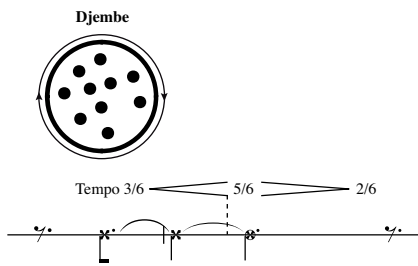

Fig. 351 Entgleisungen, p. 3.

Additionally, the djembe is also shaken. As apparent from figure 352, the action is executed with tempo 4/6 (while the player is advised to close the hole with the hand if necessary)¹.

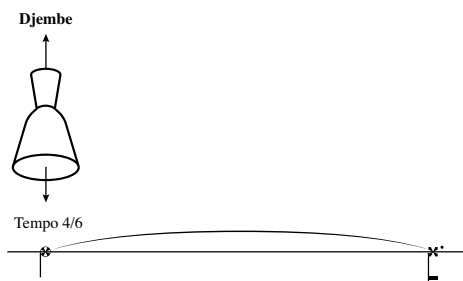

Fig. 352 Entgleisungen, p. 31.

In no. 7 the action of filling a djembe with marbles and rice itself is depicted. As apparent from figure 353, the instrument is at first reversed, which is notated by means of a time-related starting point and endpoint in combination with the direction reverse the djembe, and then filled with single marbles, two marbles or rice (cf. figure 235 in the chapter on percussion instruments).

¹ Cf. Entgleisungen, p. 31.

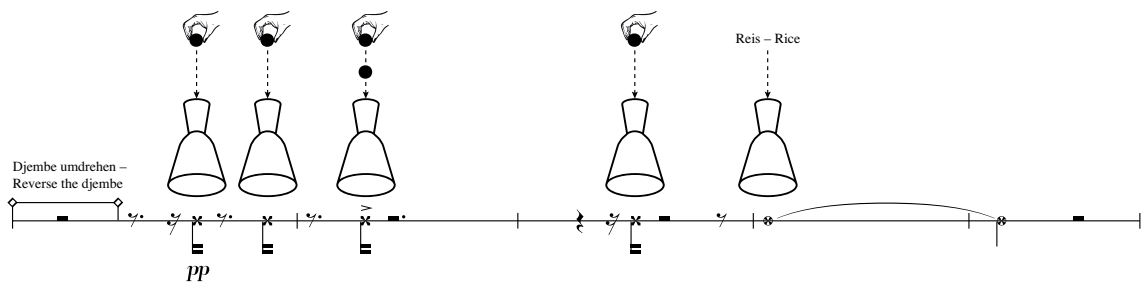

Fig. 353 Filterspiel, p. 21.

Further, playing the snares is another unconventional technique applied in both works (cf. section ‘4. 2. 6 Playing the snares’). In no. 7 the snares of a drum are, for instance, strummed. Both strummings (upbeat and downbeat) involve all strings (cf. figure 240 in the chapter on percussion instruments):

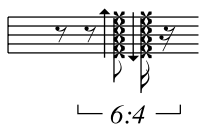

Fig. 354 Filterspiel, p. 19.

Moreover, in *Entgleisungen* complex motions are executed *sulle corde* by means of a plastic brush. In figure 355 the snares are off, and the player is supposed to move the brush up and down the snares (cf. figure 241 in the chapter on percussion instruments):

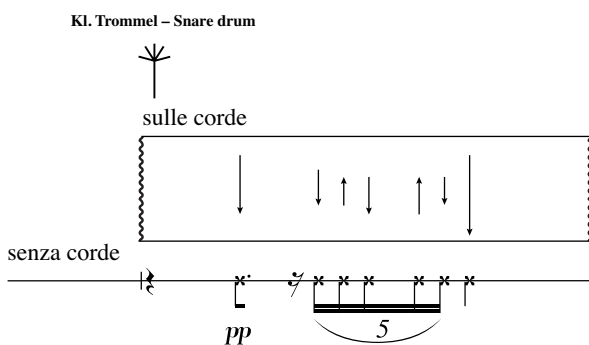

Fig. 355 Entgleisungen, p. 1.

Moreover, as apparent from figure 356, the percussionist is in no. 7 required to perform a singular rubbing motion on the (bottom) head of a snare drum (KT, as in the German *Kleine Trommel*, meaning snare drum) and the same motion on the head of a tom-tom. During the motion on the snare drum, the strings are crossed six times.

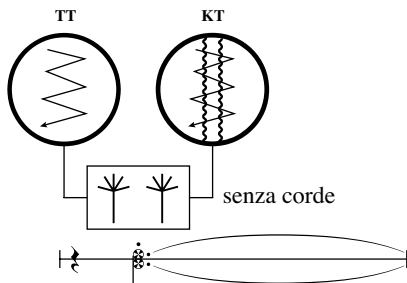

Fig. 356 Filterspiel, p. 13.

Furthermore, ‘pitch’ bending in work no. 7 is employed in various ways. As described in section ‘4. 3 ‘Pitch’ bending – the extended *glissando*’, ‘pitch’ bending articulations may be depicted by means of the transposition system. It is in ‘Filterspiel – Music for conferences’ used to make the player raise the ‘pitch’ of a tom-tom by controlled hand or elbow pressure. As apparent from figure 357, the point of impact is additionally gradually shifted (cf. figure 245 in the chapter on percussion instruments).

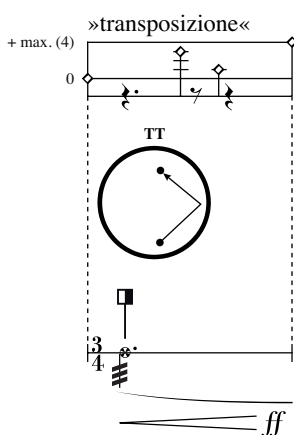

Fig. 357 Filterspiel, p. 5.

The ‘transposition’ system is also used to notate the lowering of a tam-tam into a tub of water. As apparent from figure 358, six levels are used to depict that the instrument’s ‘pitch’ is lowered while the point of impact is constantly the highest spot of the tam-tam.

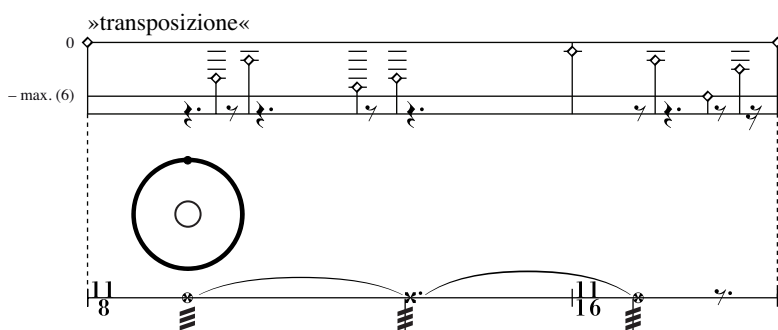

Fig. 358 Filterspiel, p. 26.

Furthermore, hand muffling (cf. section ‘4. 4. 2 Hand muffling and its notation’) is used in nos. 2 and 7. Since in both cases the initial direction *sempre lasciar vibrare* is given¹, the method of notation presented in the percussion instruments’ figure 248 is employed. For example, in *Entgleisungen* a gong is scraped for the duration of a dotted quaver. The muting sign is then used to depict that the gong is completely muted a dotted semiquaver rest after the scraping has ended:

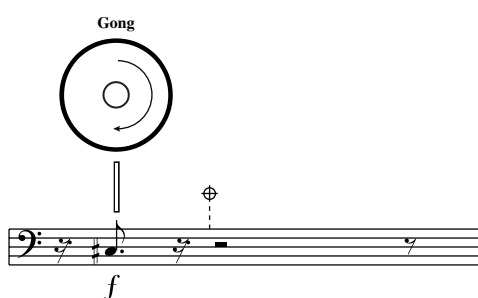

Fig. 359 Entgleisungen, p. 37.

¹ Cf. *Entgleisungen*, p. 1 (see above) and *Filterspiel*, p. 1.

In *Filterspiel – Music for conferences* the muting of single bars is also requested. As apparent from figure 360, the percussionist is supposed to attack a vibraphone's bars $e^b1 - g^1 - b^1/E^b4 - G^4 - B^b4$. After a quaver rest bar g^1/G^4 is muted, and a dotted crotchet rest after this action, the other bars are muted (while the speed of the fan is gradually changed from slow to fast).

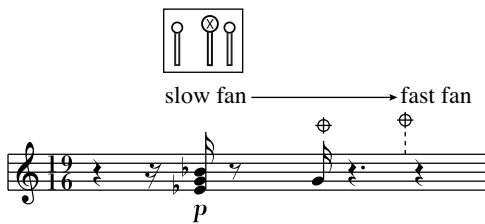

Fig. 360 *Filterspiel*, p. 4.

Further, the stop attack (cf section ‘4. 4. 3 The stop attack and its notation’) is used in both works. For instance, in no. 7 the percussionist is required to attack the centre of a tom-tom. However, he is not supposed to let the beater bounce back, but to press it down firmly after the attack:

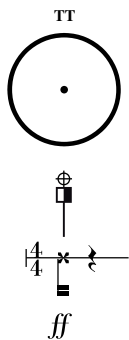

Fig. 361 *Filterspiel*, p. 4.

Finally, the wah-wah effect is employed in no. 7. In the example presented in figure 362, it can be seen that a maraca is shaken. The player is supposed to produce the wah-wah effect by opening and closing the hand. Additional articulation symbols – in this

case a *legato* slur and *staccato* dots – are used to determine the character of the transitions (cf. section ‘4. 4. 4 The wah-wah effect and its notation’).

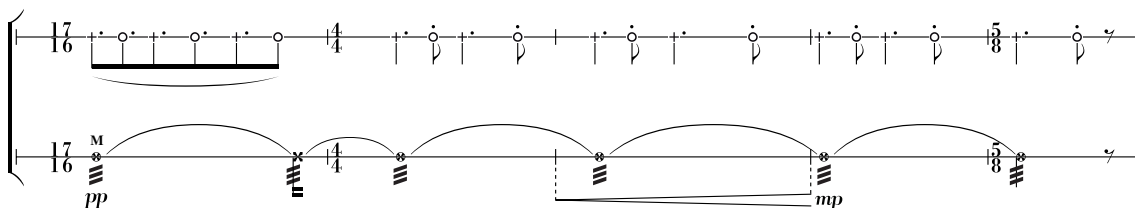

Fig. 362 Filterspiel, p. 25.

8.3 Plucked instruments

The work relevant for this section is *Three songs* (no. 8) while the unconventional playing techniques used within the piece are, as far as possible, sorted with reference to the chapter on plucked instruments.

A number of extended *pizzicato* techniques are employed in no. 8 while the ordinary plucking is requested by the direction *pizzicato*. As mentioned in section ‘5. 1 Extended *pizzicato*, *tremolo* and trill techniques and their notation’, this means that a convention is violated. Therefore, at the first occurrence of this direction it is explained that the *pizzicato* is used similarly to the way it is used on string instruments¹.

One extended *pizzicato* technique performed by the guitarists is the *pizzicato* with the left hand. As apparent from the example presented in figure 363, it is executed as a fingernail *pizzicato*. Since a string clef system and a spherical note head is employed, the *pizzicato* is played inside the headstock (cf. section ‘5. 5 Playing exceptional spots and its notation’). The direction *pizzicato* was used before and is the standard articulation for the guitar. Therefore, only the bracketed direction *mano sinistra* is given in the example.

¹ Cf. Songs, p. 1.

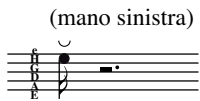

Fig. 363 Songs, p. 1.

Moreover, as apparent from figure 364, another extended *pizzicato* technique used within the work is the plectrum *pizzicato*. In this example it is executed on (the written) position $f^2/F5$ of the D-string (the system is in treble clef). Since a diamond-shaped note head is used and an off-node position depicted, an exact muting stop is supposed to be fingered (cf. section ‘5. 7. 1 Exact muting stops and their notation’).



Fig. 364 Songs, p. 1.

Additionally, in no. 8 the player is also required to execute a lateral *Bartók pizzicato* on the lowest string (cf. figure 256 in the chapter on plucked instruments):

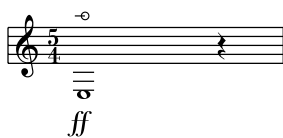

Fig. 365 Songs, p. 1.

Further, as explained in section ‘5. 2 Common and extended playing positions on the string and their notation’, the four playing positions *sul tasto*, *ordinario*, *quasi sul ponticello* and *sul ponticello* can be used for the guitar¹. These positions are, as apparent from figure 366, also used in no. 8 for the progressive modification of the point of plucking (cf. section ‘5. 3. 1 The progressive modification of the point of plucking and

¹ Cf. *ibid.*, p. 1.

its notation’). However, since the additional direction *non pizzicato* – which is bracketed here because it is also employed on the previous pages of the score¹ – is given, the player is solely supposed to slide up and down the A- and E-string with the plectrum (cf. section ‘5. 3. 3 The vertical *glissando* with/without plucking’). Additionally, the two strings are muted because the player fingers off-node positions with harmonic pressure (also cf. figure 19 in the chapter on string instruments).

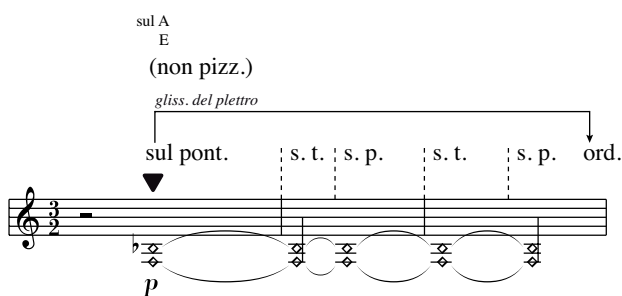

Fig. 366 Songs, p. 13.

Further, several extended modes of attack are used in the piece. Most of these include the utilisation of a bow, which is requested – as on string instruments – by means of the direction *arco* (cf. section ‘5. 4. 2 The utilisation of a bow and its notation’). As apparent from figure 367, the guitarist is supposed to bow the D-, A and E-string simultaneously. This is because only the two outer strings may be distinctly bowed (and none of the middle strings), but it is possible to distinctly bow either only the lowest or the highest three strings.



Fig. 367 Songs, p. 15.

¹ Cf. *ibid.*, pp. 11f.

The bow is then used for the execution of a number of extended *battuto* techniques. As can be seen in figure 368, the player is at first supposed to hold the guitar like a violincello, which is requested by the direction *al violincello*. This direction is used with reference to the direction *al mandolino*, which commonly determines holding a string instrument like a mandolin (cf. section ‘2. 1 Extended *pizzicato* techniques and their notation’). The guitarist is then supposed to perform a *battuto* with the screw (*colla vite battuto*) on the fretboard. This action is depicted by an additional notation system placed above the normal one while the playing positions on the fretboard are notated by diamond-shaped note heads (cf. figure 259 in the chapter on plucked instruments). In the example the player at first employs harmonic fingering and executes *battuti* on the fretboard. After the third *battuto* the left hand is released and a left hand *pizzicato* performed. Simultaneously with the *pizzicato*, the player moves the screw of the bow vertically. In order to prevent the player from executing a fourth *battuto*, followed by a vertical *glissando*, the direction *colla vite toccato* is employed here. Further, an additional *legato* slur is used to outline that the previous *battuto* and the *toccato* are connected and hence, actually, the screw is not released (cf. figure 32 in the chapter on string instruments).

Fig. 368 Songs, p. 17.

Moreover, strumming is also requested in *Three songs*. As apparent from figure 369, the player is, for example, supposed to strum the e-, B- (H = B) and G-string inside the headstock (downbeat) with a plectrum (cf. section ‘5. 4. 5 Strumming and its notation’).

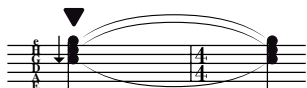

Fig. 369 Songs, p. 7.

Further, besides exact muting stops, another extended stopping technique – referred to as *barré* stops – is requested in no. 8. As explained in section ‘5. 7. 3 *Barré* stops and their notation’, it is not necessary to depict the *barré* stop when only single tones of the chord are played, but it would be helpful to additionally notate it in brackets above the normal notation system. Therefore, the *barré* stop is, in the example presented in figure 370, depicted in this way. As is apparent, the player is supposed to employ harmonic fingering and constantly execute a plectrum *pizzicato quasi sul ponticello*. In order to depict the utilisation of the plectrum in a clearer manner, the symbol is not placed above every single note/stop, but a curly bracket employed.

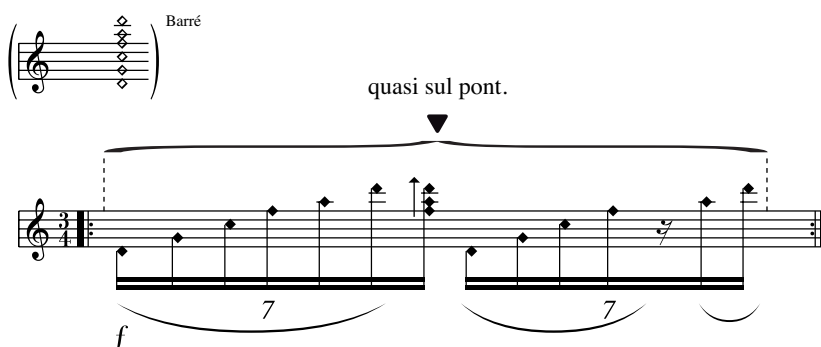

Fig. 370 Songs, p. 4.

Finally, various percussive effects are utilised in *Three songs*. For example, the guitarist is, as can be seen in figure 371, required to perform three strokes on the body

with the knuckles (cf. section ‘5. 8 Percussive effects and their notation’) and, while doing so, shift the point of contact (also cf. figure 204 in the chapter on percussion instruments). Since, in the case of the fifth note, the additional direction *lasciar vibrare* is utilised, the strings are at this point not muted, but open and further vibrate.

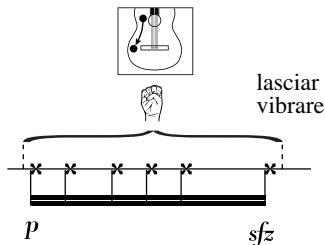

Fig. 371 Songs, p. 5.

Further, even rubbing motions are supposed to be executed on the body of the guitar. In figure 372 the player is, for instance, required to use the tips and fingernails of the thumb, index, middle and ring finger in order to execute a repetitive circular motion on the body of a steel-string guitar (a contact microphone is attached to the surface). Additionally, the tempo of this action is determined as 4/6 (also cf. figure 220 in the chapter on percussion instruments).

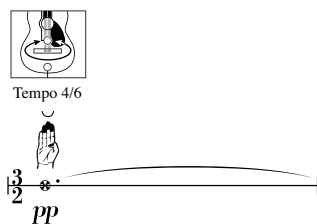

Fig. 372 Songs, p. 13.

8. 4 Keyboard instruments

This section consists of examples taken from the pieces *Entgleisungen* and *Zu vier Händen – Interventionen für Konzertflügel* (no. 3). The unconventional playing tech-

niques used within these works are, as far as possible, sorted with reference to the chapter on keyboard instruments.

Extended *pizzicato* techniques are employed in both works. One of them, the key *pizzicato*, is, however, only used in no. 2. As apparent from the example presented in figure 373, the pianist is supposed to pluck the keys $c^1/C4$ and $a^1/A4$ (the system is in treble clef), which is required by the direction *pizzicato* in combination with x-shaped note heads (cf. section ‘6. 1. 1 The *pizzicato* on the keys and its notation’).



Fig. 373 Entgleisungen, p. 6.

Further, in both pieces the *pizzicato* on the strings is utilised. Since assistants, in nearly all cases, are requested to play inside the piano, the *pizzicato* on the strings is depicted by means of a distinct notation system. However, in no. 2 the pianist himself also plucks the strings. In this case, a box is used in order to outline that this action takes place inside the piano (cf. section ‘6. 1. 2 The *pizzicato* on the strings and its notation’). As mentioned in section ‘6. 2 Common playing positions on the strings and their notation’, the pianist normally plays close to the dampers (*sul smorzatore*):

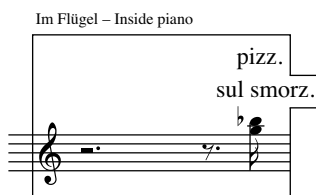

Fig. 374 Entgleisungen, p. 41.

In no. 2 the violinist and clarinetist are required to play inside the piano. The action of walking to the piano is simply requested by means of a direction: “[p]ut the violin

cautiously aside and walk as quietly as possible to the rear of the open piano. The violinist is supposed to perform various actions inside the piano in the following movement”¹. As mentioned in section ‘3. 10 Resonance effects’, the direction for such an action may be longer and contain a lesser degree of instantaneous comprehension because the player anyway needs time to, in this case, walk to the rear of the piano. In *Zu vier Händen – Interventionen für Konzertflügel* two positions are further defined for the assistant while “[o]n position 1 the strings *G3* to *C#6* need to be accessible and on position 2 the bass strings *A0* to *C#2*”².

Moreover, in no. 3 the assistant is supposed to execute plectrum *pizzicati* on the strings. In figure 375, for example, the *c³/C6*-string is plucked with a plectrum on the position *ordinario* (the system is in treble clef).



Fig. 375 *Interventionen*, p. 1.

Further, a normal *pizzicato ordinario* in that piece is combined with a silent depression of the key. Since the assistant plucks the string *f¹/F4*, the pianist simultaneously depresses it silently (cf. section ‘6. 6. 2 Depressing the keys silently and its notation’) and the direction *sempre lasciar vibrare* being initially employed for the assistant’s systems³, the string further vibrates:

¹ *Entgleisungen*, p. 16.

² *Interventionen*, no page named [foreword].

³ Cf. *ibid.*, p. 1.

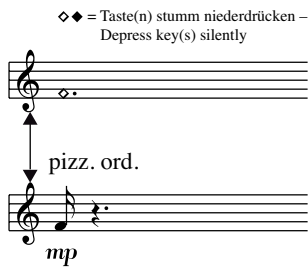

Fig. 376 Interventionen, p. 4.

Further, in both works *glissandi* on the strings are performed. In order to ensure that they may be executed without interruption, piano models that allow the performance of the requested *glissandi* are suggested – with reference to ‘Appendix B’ – in the foreword¹ (cf. section ‘6. 3. 2 The *glissando* on the strings and its notation’). In figure 377 an example of such a *glissando* is presented. As apparent, it is executed with a plectrum on the position *ordinario*. Shortly before the end of this action, the pianist depresses the pedal². Since the initial direction *sempre lasciar vibrare* was given³, some of the strings further vibrate.

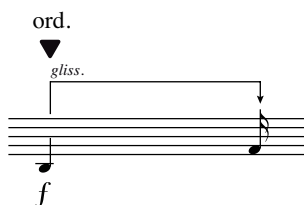

Fig. 377 Entgleisungen, p. 17.

Further, in this piece the *glissando* on the strings is combined with a progressive modification of the point of plucking. As apparent from the example presented in figure 378, the assistant is at first supposed to play a *glissando* on the strings and then, addi-

¹ Cf. Entgleisungen, no page named [foreword] and Interventionen, no page named [foreword].

² Cf. Entgleisungen, p. 17.

³ Cf. *ibid.*, p. 1.

tionally, modify the point of plucking (cf. section ‘6. 3. 3 The progressive modification of the point of plucking and its notation’).



Fig. 378 Entgleisungen, p. 28.

The modification starts on the *ordinario* position and ends, simultaneously with the *glissando* on the strings, on the *sul ponticello* position:

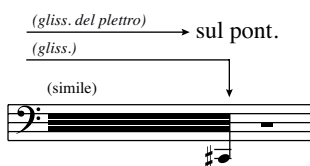

Fig. 379 Entgleisungen, p. 29.

Further, in no. 3 the vertical *glissando* without plucking is used. In the example presented in figure 380, the assistant is supposed to use the tip of a bottleneck (cf. section ‘4. 2. 1 The extended utilisation of the agents of attack’) in order to perform a vertical *glissando*. Even though the string is not plucked (*non pizzicato*), a strong *glissando* of the pitch – and not mainly of the sliding noise – may be perceived. This is because the pianist plays the two tones g^1/G^4 and ab^1/A^b4 involved in the vertical *glissando* (cf. section ‘6. 3. 4 The vertical *glissando* on the strings with/without playing and its notation’):

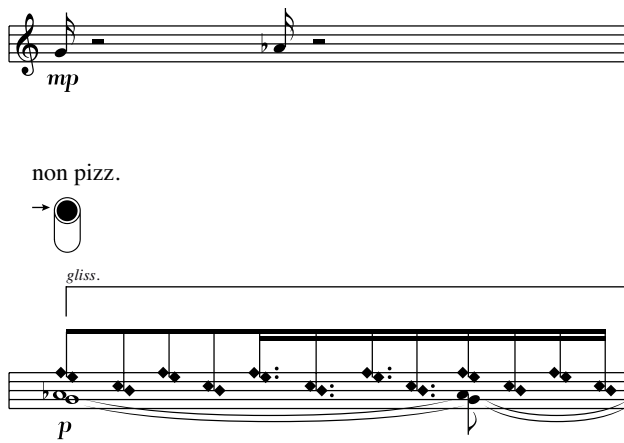

Fig. 380 Interventionen, p. 3.

Moreover, in no. 3 a vertical trill-*glissando* (cf. section ‘2. 2. 2 The bow-*glissando*’ for this kind of *glissando*) is executed. Again, the assistant is supposed to use the tip of a bottleneck in order to repetitively slide up and down the string:

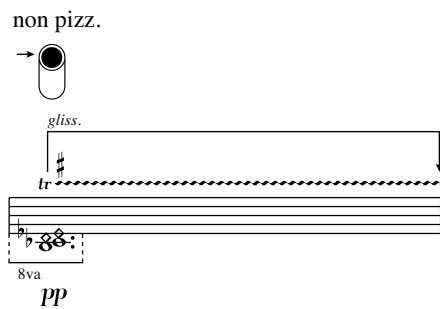

Fig. 381 Interventionen, p. 6.

Furthermore, several extended modes of attack are requested in nos. 2 and 3. For example, in *Entgleisungen* the *toccato* articulation is executed by means of a threaded rod. A sizzle effect is produced because the assistant has previously played a *glissando* on the strings (cf. sections ‘6. 4. 1 The *toccato* and its notation’ and ‘6. 6. 1 Clusters’), and, at the time of the *toccato*, the strings still vibrate since the pedal is depressed¹. As

¹ Cf. *Entgleisungen*, p. 40.

apparent from figure 382, the threaded rod is then attached to the chromatic cluster ${}_2A - A/A0 - A2$ on the *sul ponticello* position.

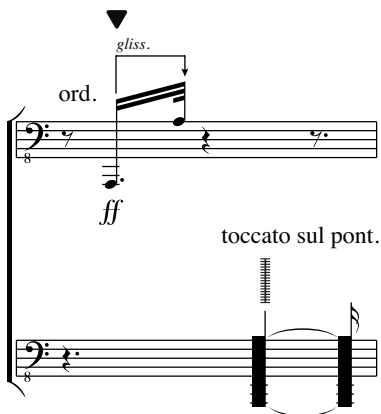

Fig. 382 Entgleisungen, p. 40.

Additionally, several beaters are used in the two works to execute strokes on the strings. In the example presented in figure 383, it is, for instance, requested to perform two strokes with a metal headed mallet¹ on the *ordinario* position (cf. section ‘6. 4. 2 The utilisation of beaters and its notation’). Two strings are, in this case, supposed to be hit simultaneously.

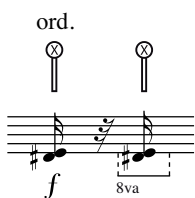

Fig. 383 Entgleisungen, p. 23.

Further, when items (and not common beaters) are used, the additional direction *battuto* is employed in order to request strokes. In figure 384 the assistant is, for instance, supposed to execute a stroke with the tip of a threaded rod (cf. section ‘6. 4. 3 Extended battuto techniques and their notation’). Previous to this, he is required to use

¹ For all beater symbols cf. the foreword of the respective work.

the three-ded rod's tip in order to execute a *glissando* on the strings. In this case, no additional direction needs to be given.

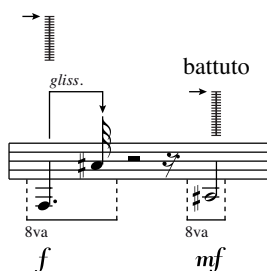

Fig. 384 Interventionen, p. 12.

Further, cluster stops are utilised in nos. 2 and 3. For instance, in *Entgleisungen* the pianist is supposed to play the diatonic cluster $c\# - e\flat^1 / C\#3 - E\flat^4$ on the black keys and the diatonic cluster $A - h / A2 - B3$ on the white keys simultaneously (cf. section ‘6. 6. 1 Clusters’). They are notated here by means of two notation systems in order to achieve a clear appearance of the score, but could alternatively be depicted by a single notation system (cf. figure 296 in the chapter on keyboard instruments):

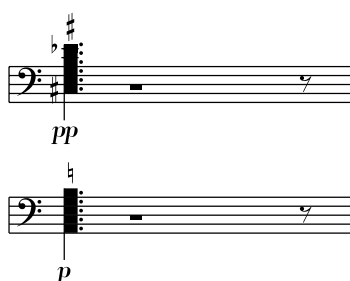

Fig. 385 Entgleisungen, p. 1.

Chromatic clusters are also employed in both works. As apparent from figure 286, the pianist in *Zu vier Händen – Interventionen für Konzertflügel* is supposed to play a diatonic cluster ${}_1F - F/F1 - F2$ on the white keys, which is followed by a chromatic cluster ${}_2A - F\#/A0 - F\#2$.

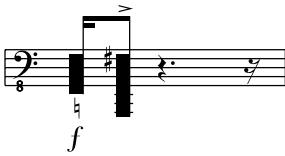

Fig. 386 Interventionen, p. 12.

Further, in nos. 2 and 3 exact muting and ‘half harmonic’ stops as well as harmonics are required. When such fingerings are employed, the additional direction *non pizzicato* (or *non battuto*) is used in order to outline that the string is only fingered and not plucked. As can be seen in figure 387, an exact cluster muting stop is depicted. It is executed on the string cluster $b^1 - eb^2/Bb4 - Eb5$ (the system is in treble clef). The assistant is supposed to attach his hand on the minor sixth position and hence mute all tones the pianist plays (cf. section ‘6. 6. 3 Exact muting stops/harmonics and their notation’).

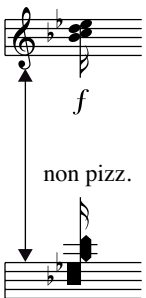

Fig. 387 Interventionen, p. 1.

Moreover, in figure 388 harmonics are produced because the assistant executes harmonic fingering on the major third position of the $a^1/A4$ -string (fifth partial), on the minor third position of the $h^1/B3$ -string (sixth partial) and on the major third position of the $c^{\#2}/C\#5$ -string while the pianist plays these tones.

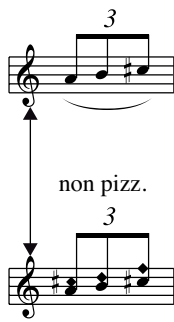

Fig. 388 Interventionen, p. 2.

Moreover, as apparent from figure 389, in no. 2 the pressure applied to the string is also gradually increased. In the beginning of the example, the cluster muting stop is fingered with normal pressure. After the duration of a dotted minim, ‘half harmonic’ pressure is reached. Since this means that an exact muting stop is transferred to a ‘half harmonic’ stop, a new note and a *legato* slur is employed (cf. section ‘6. 6. 4 ‘Half harmonic’ stops and their notation’).

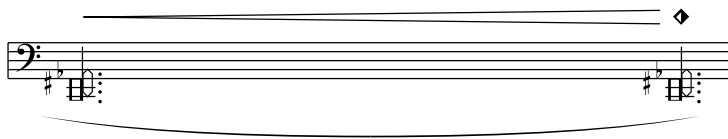

Fig. 389 Entgleisungen, p. 27.

Additionally, ‘half harmonic’ stops are also executed by means of items in nos. 2 and 3. In *Zu vier Händen – Interventionen für Konzertflügel*, for example, a threaded rod is used to perform a ‘half harmonic’ stop on the cluster ${}_2A - C\#/A0 - C\#2$. Subsequently, the same cluster is then muted with ‘half harmonic’ pressure by means of the assistant’s arm:



Fig. 390 Interventionen, p. 12.

Further, in both works pedal strokes are utilised. They are requested in combination with depressing or releasing the pedal. In the example presented in figure 391, the pianist is supposed to release the pedal violently and simultaneously play the tones *F#/F#2* and *A/A2* (cf. section ‘6. 7. 2 Pedal strokes’).

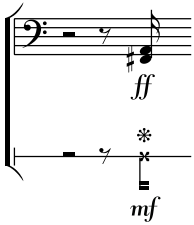

Fig. 391 Entgleisungen, p. 41.

Furthermore, several percussive effects are requested in nos. 2 and 3. In the foreword of both works the complete depiction of the piano’s body is presented (cf. figure 309 in the chapter on keyboard instruments) while it is explained that “[w]hen the construction type of the utilised model varies from the graphic depiction, the player needs to redetermine the point of impact with regard to the requested sound”¹ and hence the material that is struck (cf. section ‘6. 8 Percussive effects and their notation’).

Moreover, in no. 3 strokes on the body and rubbing motions are requested. In the example presented in figure 392, the player is supposed to strike the frame with a wooden headed drumstick and then use the stick to execute a rubbing motion on the soundboard (cf. section ‘4. 2. 4 Rubbing and bowing motions’ for the rubbing motion).

¹ Entgleisungen, p. 18 and Interventionen, p. 5.

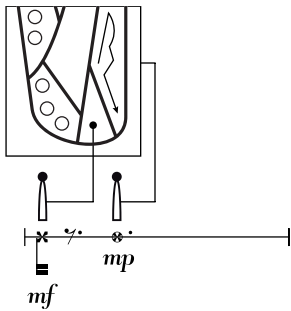

Fig. 392 Interventionen, p. 13.

Strokes on the keyboard lid and the wooden strip are also requested. For example, in *Entgleisungen* the pianist is supposed to hit the left wooden strip with the side of the fist, after a dotted crotchet rest, use a wooden headed mallet in order to strike the lid on the right side and finally, after a crotchet and semiquaver rest, strike the lid on the left side with the tips of all five fingers (cf. figure 310 in the chapter on keyboard instruments and figure 92 and 93 in the chapter on string instruments):

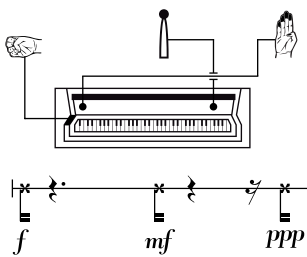

Fig. 393 Entgleisungen, p. 11.

Further, slamming and opening the keyboard lid is also requested in both pieces. As apparent from figure 394, the pianist is supposed to slam the lid in a loud manner and re-open it quietly (cf. figure 312 in the chapter on keyboard instruments).

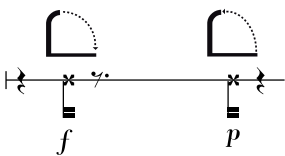

Fig. 394 Interventionen, p. 4.

Moreover, in nos. 2 and 3 the *glissandi* without depressing the keys requested are always diatonic and either performed solely on the black or white keys. The pianist makes use of a plectrum, the fingers or a comb in order to execute them. As apparent from figure 395, he utilises both hands to slide over the keys. In the right hand he is supposed to hold a plastic comb (thinner teeth on the left side) and perform two *glissandi*, the first one on the black and the second one on the white keys. The left-hand *glissandi* are executed either by means of the tips and fingernails of the index and middle finger or a plectrum. Further, between the two left-hand slides on the white keys, a key *pizzicato* is performed (cf. figure 313 in the chapter on keyboard instruments).

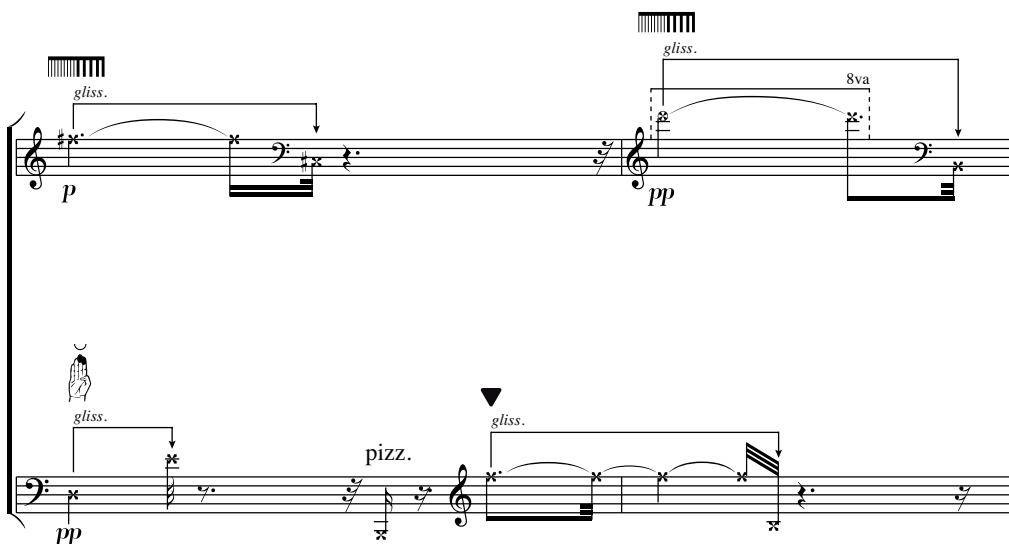

Fig. 395 Entgleisungen, p. 6.

Finally, *glissandi* on the tuning pins are requested in *Entgleisungen*. As can be seen in figure 396, the pianist is supposed to perform a *glissando* with the entire length of a bottleneck from the pins $d^1/D4$ to the pins $ab^1/A\flat4$ and back to $d^1/D4$ (cf. figure 314 in the chapter on keyboard instruments).

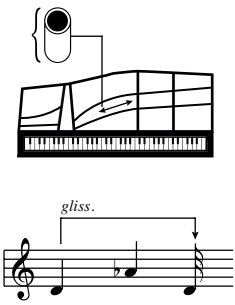

Fig. 396 Entgleisungen, p. 35.

8.5 Summary

In this chapter the application of some of the unconventional playing techniques is explained by means of presenting examples of five works. The chapter is divided into the sections wind instruments, percussion instruments, plucked instruments and keyboard instruments. The playing techniques presented in each section are, as far as possible, sorted with reference to the chapter on the respective instrument group. As apparent from the examples, a large number of unconventional extended playing techniques are used in the compositions while the methods of notation all agree with the developments presented in this thesis or may be regarded as slight elaborations.

9. CONCLUSION

In this thesis coherent and consistent methods of notation for most of the unconventional extended playing techniques of the Western orchestral instruments were developed. In order to fulfil this task, a set of criteria was defined and used to judge previous methods of notation. On the basis of these analyses a system of methods that agrees with the criteria was then developed while it was considered that the additions are compatible with, and distinct from, all other signs of the system. This procedure was executed with regard to the unconventional playing techniques of string instruments, wind instruments, percussion instruments, plucked instruments and keyboard instruments. The developments made within this work were subsequently applied in compositional works. Additionally, older instrumental works were revised by replacing earlier methods of depiction with the new developments. Examples from these scores were then presented in the thesis in order to show how the new methods of notation may be implemented in musical works.

The extension of traditional notation, as demonstrated in this thesis, is a contribution to knowledge because there has not yet been a systematic approach towards the notation of the unconventional elements in music. Moreover, all handbooks on instrumentation that grapple with extended playing techniques are not as extensive and detailed as the work at hand. Further, the compendiums cited in this work often present examples of depiction for a particular augmented technique without acknowledging that there is no conventional method of notation for it or without citing the work the method of depiction is borrowed from.

9.1 Discussion

The developments made within this work are coherent because they all agree with the criteria postulated in the introduction. All previous methods of notation were discussed with regard to these criteria. Hence it was hence examined if they are simple, exact and closely related to traditional notation. As a result, either one of the already existing methods was proposed or, if they all failed to agree with the criteria, a simpler, more exact and/or more traditional method was suggested. However, in some cases, one of the criteria was emphasised and the others were set aside. An example for this is the discussion of the *saltando*, *balzando* and *toccato*. As explained in section ‘2.3.3 The *saltando*, *balzando* and *toccato* and its notation’, these techniques are related to the traditional articulations *col arco/legno gettato* and *col arco/legno battuto*. Consequently, they are notated in the same fashion and hence by means of directions. However, this means that the third criterion (close relation to traditional notation) is emphasised and the second criterion (simplicity) neglected. This is because the described articulations may theoretically be notated in a simpler manner than by utilising a direction, e. g. by means of an illustration. Nevertheless, the emphasis of the third criterion is consequently applied in the work because any unconventional articulation that is strongly related to a conventional articulation is depicted similarly to the conventional one. Examples for this are the *pizzicato* effect on wind instruments, which is notated in the same way as the *pizzicato* on string instruments (cf. section ‘3.2.2 The *pizzicato* effect and its notation’), the slap tongue articulation, which is notated in the same way as the *Bartók pizzicato* because the character of both sounds is similar (cf. section ‘3.2.3 The slap tongue’), or the playing techniques of plucked instruments that may also be produced on string instruments and, therefore, are always notated in the same way (cf. the chapter on plucked instruments). Similarly, since many extended techniques that may be

executed on the strings of a piano strongly resemble the techniques of the harp, they are also always notated in the same way (cf. the chapter on keyboard instruments). The third criterion is, in such cases, indeed emphasised. However, the performance of these techniques is also facilitated because it is easier for instrumentalists to comprehend a particular unconventional playing technique when it is depicted in the same way as its conventional counterpart.

Further, the developments made within this work are consistent because, as mentioned, they are compatible with, and distinct from, all other signs of the system. Hence no extension suggested in this work compromises any of the conventional methods and the other developments. An example for such a consistent extension is the transposition system (cf., for instance, figure 130 in the chapter on wind instruments). It is used to depict an unconventional technique, but is compatible with the conventional depiction of tones. Additionally, all methods introduced in this work are distinct from each other. This means that the same method is not used to depict two distinct articulations of the same instrument, e. g. the *Bartók pizzicato* symbol is not used to request the *Bartók pizzicato* and the *saltando*. However, the *Bartók pizzicato* symbol may be also used to request the slap tongue articulation on wind instruments because the player cannot confuse it with the original articulation. This is because a common *Bartók pizzicato* can be only produced on string or plucked instruments.

However, even though the developments are hence coherent and consistent, it has to be acknowledged that the approach towards the notation of unconventional musical elements presented in this thesis is ambitious and has its flaws. Some of these limitations have already been hinted in the introduction and are discussed in more detail below.

9.1.1 On the practicability of the extensions

The practicability of the developed methods was not yet adequately observed. This is because various compositions that make use of the developments exist, but most of them have not yet been realised. A final estimate of the usability can be only performed when an adequate number of pieces, including works for solo instruments, small/large chamber ensemble and orchestra, have been realised. But the composition and realisation of such works is a long process, which could not be completed before finishing this thesis. This is because, for instance, the realisation of the works composed and revised during the writing process of the thesis require a large number of performers. Moreover, the performers need to rehearse the work adequately. They hence have to spend a lot of time on studying the utilised methods of notation, practicing the playing techniques and interacting with each other. Therefore, great effort has to be expended for a single performance of each piece. Moreover, the practicability can be only adequately observed after a number of performances because each interpreter may react differently to the methods of notation. Thus an even larger effort needs to be expended in order to gain a final estimate concerning the practicability of the developed methods. Additionally, so far only eight works that make use of the developments have been composed. In order to further test the applicability of the methods in scores, more pieces need to be produced. This is a long process because it takes a lot of time to compose, for example, a work for orchestra while the subsequent realisation of the piece further prolongs the observation process. It could be, however, shortened if other composers would also make use of the methods in their works. Nevertheless, a preliminary estimate concerning the practicability of the methods, with regard to the revision, composition and realisation of the works presented as examples in this thesis, is given in section '9.2 Practical experiences'.

9. 1. 2 On the limitations of the exactness criterion

The criterion of exactness is limited. This is because the factor of interpretation may lead to an uncertainty between the depiction and the realisation. Additionally, when human performers are involved in the realisation of a musical work, a requested technique might be executed in an inaccurate manner. Furthermore, during the writing of the thesis, it had to be acknowledged that it is also not possible to control every little detail of every instrumental technique, but rather it is necessary to transfer the responsibility for some of the parameters to the interpreter. One example is the pitch bending articulation. This *glissando* technique may be, in the case of woodwinds, performed in different ways. However, the introduction of a special method of notation for each bending technique would have resulted in a more complex notation system. Therefore, a general transposition system was used to depict the technique and the exact performance left to the player's discretion (cf. section '3. 4 Pitch bending – the extended *glissando*'). Another example is the *pizzicato* on the strings. When requesting the player to pluck a string, which is made of two or three wires, it is not determined if he is supposed to pluck only one or all wires. This is because it would also lead to a very complex method of notation, which is at the same time dependent on the utilised piano model. Instead, the decision whether to pluck one, two or three wires is transferred here to the player (cf. section '6. 1. 2 The *pizzicato* on the strings and its notation').

9. 1. 3 On the preferences of composers

Composers might want to use other techniques than the ones described in the thesis. However, in order to limit the extent of the work, some of the unconventional means of sound production had to be neglected. There are numerous ways of preparing orchestral instruments while these preparations may lead to the introduction of new playing

techniques that are not discussed in the thesis. Some instruments, such as the organ, harpsichord or plucked idiophones as well as vocal techniques, were also not discussed while it is impossible to present a complete notation system for the innumerable non-instrumental sounds. Additionally, the development of a notation system for electroacoustic music would also be desirable, especially in order to facilitate the notation of live-electronics. Works on the notation of unconventional vocal techniques and electroacoustic music have – as apparent from the scores presented in ‘Appendix C’ – already started. Moreover, it would especially be helpful to further augment the work by discussing instrumental preparations and the resulting playing techniques as well as the unconventional techniques of the organ and harpsichord.

Further, it needs to be admitted that even though there are, as shown in the introduction, good reasons for the utilisation of the criteria, they might not be accepted by all composers, and, even if accepted, they might lead to results other than the ones presented in this work. Concerning these possible limitations, it may be replied that the system presented in the thesis is – as mentioned – regarded as an initial suggestions that may be adapted to the needs of the composer who makes use of it. Hence the system may be changed, revised or augmented. If changed, the analyses and suggestions may serve as a source of inspiration and may, in any case, hopefully contribute to facilitating the composition and performance process as well as the work contribute to the process of conventional methods of notation coming into existence for most articulations in the (distant) future. If revised, methods that agree better with the criteria could be developed and replace the methods suggested in thesis, whereas if augmented, the new techniques would simply have to be notated in accordance with all other techniques presented in this thesis. This thesis should be, therefore, considered as a contribution, starting point and work in progress.

9.1.4 On the constraints of the paper size

The vertical space¹ of a score is limited. This problem is especially important for this thesis because most of the developed methods of notation require a larger amount of vertical space than the methods used to notate the conventional elements of music. Such a limitation will become most notable in compositions for large ensemble or orchestra. However, there have been various attempts to overcome it. Many composers have extended the vertical space by producing large-format scores. Famous examples that enable the depiction of a huge number of simultaneous events are Ligeti's *Apparitions*, Stockhausen's *Punkte*² or Boulez' *Notation I-IV*³. Nevertheless, it needs to be acknowledged that the number of concurrent events has to be limited. This is because when a score is very large, it becomes – either due to its sheer size or the number of simultaneous events – unreadable, which would in turn violate the third requirement because instantaneous comprehension would then be compromised.

9.2 Practical experiences

As mentioned, a final estimate concerning the practicability of the developed methods of notation cannot be presented here. However, since four works have been revised by replacing earlier methods of notation with the new developments and in three works the extended notation system has already been applied, first experiences, with regard to the utilisation of the methods, may be described here. Moreover, a preliminary estimate concerning the practicability of the methods used in *Tatsachen in zwei Sätzen* and *Klanggruppen* (cf. chapter '7. Practical example I: Klanggruppen') is presented with regard to the experiences gathered during their realisation.

¹ The available space from the top to the bottom of a page.

² Karlheinz Stockhausen: *Punkte*. For orchestra. London 1966.

³ Pierre Boulez: *Notation I-IV*. For orchestra. London 1978.

The writing of this thesis has strongly impacted on the way I compose. Before being in possession of an extended notation system, composing pieces that involve a large number of unconventional playing techniques was a cumbersome procedure. Most works of mine are inspired by other compositions. For instance, *Tatsachen in zwei Sätzen*« (no. 1) was inspired by two of Lachenmann's works, *Pression* and *Toccatina*, as well as by Pröve's *Firebird*. Some of the techniques Lachenmann and Pröve make use of were also employed in no. 1. However, other methods of notation were chosen in order to depict certain playing techniques in a more exact manner or further augment the articulations. For instance, I notated the harmonic-*glissando* without bowing (cf. section '2. 2. 1 The harmonic-*glissando* without bowing and its notation') in that piece by means of a diagrammatic system with twelve levels, resembling the transposition system (see above). This system was related to the division of the violin's fingerboard into twelve areas of the same length. Additionally, I applied a method of notation derived from the one used by Pröve for the depiction of fingering in between the fingerboard and bridge (cf. figure 46 in the chapter on string instruments) in order to request fingering behind the bridge. Besides studying these works, I have also consulted handbooks on instrumentation, especially the one by Sevsay, which is in this thesis used as the main reference book. Unfortunately, the harmonic-*glissando* without bowing or fingering behind the bridge is not reflected in Sevsay's work. However, articulations, such as bowing on/behind the bridge, are part of the book. The initial methods I used to depict these two techniques in no. 1 were derived from Sevsay (cf. figure 48 and 55 in the chapter on string instruments): in *Tatsachen in zwei Sätzen* I made use of the traditional system and x-shaped note heads to notate the string that is bowed. However, instead of adding a symbol to the note tail I placed symbols above the notes that seemed to contain a greater degree of instantaneous comprehension. A line, representing the

bridge, was used to request bowing on the bridge and a dotted line depicted playing behind the bridge.

Some of the described methods were developed before the composition process and some were developed or changed during the composition process. The effort to write this solo work was enormous and I had to constantly interrupt composing in order to study the scores or the handbook, think about the method I should employ or alter the already applied methods because another method seemed to suit my needs in a better way. The composition process of the works nos. 2 to 4 may be described similarly. I had to spend a lot of time on studying previous methods of notation, reading the relevant handbooks and developing new methods. However, I was able to use some of the methods of notation I had developed during the composition process of one work in the following works when certain techniques were repeatedly applied, e. g. the harmonic-*glissando* without bowing is used in nos. 1 and 2. At that time, I described all unconventional techniques and methods as shortly as possible in the foreword of the work. Depending on the utilised articulations and number of instruments, the foreword became more or less extensive.

After finishing the chapters relevant for the works nos. 1 to 4, I have completely revised them. It was a major revision because not only did I have to swap symbols, but I had to completely replace some of the utilised methods, e. g. the diagrammatic system used to depict the harmonic-*glissando* without bowing had to be replaced by the traditional system. At the same time, the 12 equal fingerboard areas had to be translated to pitch-based fingerboard positions. Moreover, fingering behind the bridge and bowing on/behind the bridge was now depicted by means of the string clef system. The revisions I had to perform were so large that I decided to completely re-compose the works with reference to the original scores. Further, in the course of the revision process, I

decided not to explain the unconventional methods of notation in the foreword, but to extensively explain them in the appendix of the works because I wanted to provide a deeper insight into the utilised articulations.

Further, after finishing the chapter on string instruments, I composed the work *Klanggruppen* for violincello alone (no. 6). The composition process was now fundamentally different because I no longer had to constantly refer to other compositional works or handbooks and was now aware of the full potential of the instrument. I only had to decide which playing techniques I wanted to apply in the work and was able to easily notate them, simply by referring to the section that presents the development. Thus I did not have to interrupt the composition process for the development or alteration of a method. Moreover, I was now aware that the methods I was employing were simple, exact and closely related to traditional. They were hence designed the way I wanted them to be. This is also valid for the following works I composed. Since the utilisation of unconventional means of sound production was now facilitated, I was able to solely focus on the composition process itself without being distracted by shaping the notation system. Additionally, before starting with the composition of no. 6, I had recognised that my scores needed to be more accessible. This was because the appendices for the previous works had partially become extremely extensive. Understanding the methods of notation hence required spending a long time on studying the explanations. Because I had noticed this discrepancy previously, all scores did not only consist of a large appendix, but a short explanation of the method of notation at the first occurrence. Since these short explanations were, however, not sufficient for the complete understanding of the techniques they were referring to, I decided to augment them and, at the same time, delete the appendices. The short explanations had at that time been a part of the score. They were transferred to footnotes because, in the case of more

extensive explanations, the clear appearance of the score could otherwise not have been preserved. These footnotes were not as extensive as the explanations presented in the appendices because, as mentioned, the vertical space of a score is limited, and each new method of notation should become easily accessible at first sight.

Further, the realisation of nos. 1 and 6 has provided me with insight into the practicality of the methods of notation developed for string instruments and, with regard to work no. 1, partially shaped the criteria presented in the introduction. During the rehearsal of *Tatsachen in zwei Sätzen*, I was in contact with the violinist performing the piece. Since he was not very experienced with all unconventional means of sound production utilised in the composition, he was not only forced to study the meaning of the methods I had made use of, but also spend a lot of time on practicing the techniques and then rehearse the piece. What occurred to me in our conversations was that the diagrammatic system I had used to depict the harmonic-*glissando* without bowing, was confusing to him because the fingerboard was now divided into 12 areas instead of pitches. At that point, I started to realise that it would be more efficient to depict suchlike techniques, if possible, in closer relation to traditional notation because all instrumentalists are used to this system and it facilitates the performance. However, only during the writing of this thesis did I understand that it would be a lot easier to depict this motion on the string similarly to a *flageolet-glissando*. Besides the fingerboard, in that work I had also divided the body of the violin into areas and referred to these areas in the score by means of greek letters (α , β , γ etc.). However, this forced the player to learn the meaning of the letters – e. g. α equalled the part of the body left to fingerboard, β equalled the spot right to the fingerboard etc. This procedure proved to be a rather complex method of notation for simply requesting a violinist to strike the body of his instrument. When I later wrote the section on the string instruments' percussive effects, I realised

that it would be a lot simpler to depict the spot the player attacks by means of an illustration (cf. section '2. 7 Percussive effects'). This method of notation also contained a greater degree of instantaneous comprehension.

The realisation process of *Klanggruppen* was different because I barely had the opportunity to talk to the cellist. In the few conversations we had I realised that I had not adequately explained all methods employed in the piece. For instance, the special *glissando* notation lacked an explanation in the score, and I had to further explain the *saltando* and *balzando* articulation because the explanation in the footnote was at that time insufficient. However, it also occurred to me that, even if the player is well-trained and experienced with unconventional playing techniques, it is extremely important to spend an appropriate amount of time on the rehearsal. This is because a work that makes complex use of uncommon articulations will otherwise be performed inadequately.

9.3 Final remarks

As explained in the introduction, the origin of this thesis lies within the piece *Tatsachen in zwei Sätzen*. Since I wanted to use a large number of unconventional extended playing techniques in this work, I was confronted with the problem of being forced to develop methods of notation or select existing unconventional methods that served my needs in order to enable the employment of the techniques. Soon I realised that every composer interested in utilising unconventional means of sound production is confronted with the same problem. In the beginning I was hoping to provide a universal solution for this issue. However, the more I studied previous methods of notation for unconventional playing techniques, the more I had to acknowledge that composers tend to approach the problem in different ways and develop methods for purposes other than

mine. This made me realise that it is virtually impossible to develop a notation system that is accepted and used by each composer. Therefore, I decided to base the developments on my own needs as well as those of the performers and adapt them to the already accepted notation system. Subsequently, I formulated a set of criteria the future notation system should obey, analysed previous methods of notation with regard to these and developed a coherent and consistent notation system. Many of the developments were inspired by my practical experiences prior to writing the thesis since I had, during the composition process of several works, already developed methods to depict the unconventional. However, these methods have, in most cases, been elaborated and refined.

Moreover, the visual identity of the notation system I have developed in this thesis can be related to my aesthetic preferences in terms of the visual appearance of the scores: the graphic elements I make use of rarely contain redundant ornaments. By contrast, they can be described as plain and clean as well as often resembling technical drawings. These aesthetic preferences have evolved during my practice as a composer and influenced the formulation of the criteria, but have also been shaped by reflecting on these. To give an example, when realising that I wanted the methods of notation to be as simple as possible, I had to dismiss a number of methods I had previously chosen to agree with my intuitive visual-aesthetic preferences. Similarly, postulating that the methods should be closely related to traditional notation made me, as shown above by taking the example of the harmonic-*glissando* without bowing, replace methods of depiction that were based on parameters other than pitch even though they could have been depicted by referring to pitch-based notation. However, the criterion of exactness has always been a strong aesthetic preference of mine since I have always wanted my scores to be an exact depiction of the actual performance even before writing the thesis

(this is why work no. 1 is called *Facts in two movements*). The examination of Wittgenstein's *Tractatus logico-philosophicus* further confirmed this approach.

In conclusion, I can say that I hope the thesis will prove useful for other composers¹ and that the utilisation of extended means of sound production will be facilitated by the existence of a conventional extended system. This thesis is regarded as a small contribution to the emergence of such conventions.

¹ In order to facilitate the utilisation of the system, I am also going to provide the methods digitally. Composers that make use of notation software can then simply import this package and use the methods without previously designing them by means of a graphic software. The creation of such a package was suggested by my supervisor Eduardo Miranda who intends to compose a piece for piano, using some of the methods presented in this thesis.

APPENDIX A: IPA CHART

THE INTERNATIONAL PHONETIC ALPHABET (revised to 2005)

CONSONANTS (PULMONIC)

© 2005 IPA

	Bilabial	Labiodental	Dental	Alveolar	Post-alveolar	Retroflex	Palatal	Velar	Uvular	Pharyngeal	Glottal
Plosive	p b			t d		ʈ ɖ	c ɟ	k ɡ	q ɢ		ʔ
Nasal	m	ɱ		n		ɳ	ɲ	ŋ	ɴ		
Trill	ʙ			r					ʀ		
Tap or Flap		ⱱ		ɾ		ɽ					
Fricative	ɸ β	f v	θ ð	s z	ʃ ʒ	ʂ ʐ	ç ʝ	x ɣ	χ ʁ	ħ ʕ	h ɦ
Lateral fricative				ɬ ɮ							
Approximant		ʋ		ɹ		ɻ	j	ɰ			
Lateral approximant				l		ɭ	ʎ	ʟ			

Where symbols appear in pairs, the one to the right represents a voiced consonant. Shaded areas denote articulations judged impossible.

CONSONANTS (NON-PULMONIC)

Clicks	Voiced implosives	Ejectives
◌͡ Bilabial	ɓ Bilabial	ʼ Examples:
◌͡ Dental	ɗ Dental/alveolar	ɓ' Bilabial
◌͡ (Post)alveolar	ɟ Palatal	ɗ' Dental/alveolar
◌͡ Palatoalveolar	ɠ Velar	ɠ' Velar
◌͡ Alveolar lateral	ɠ Uvular	ɠ' Alveolar fricative

VOWELS

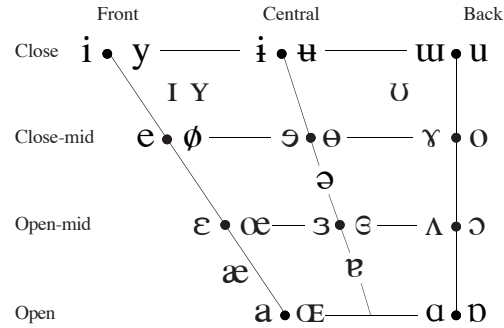

Where symbols appear in pairs, the one to the right represents a rounded vowel.

OTHER SYMBOLS

- ɱ Voiceless labial-velar fricative
- ɰ Voiced labial-velar approximant
- ɰ Voiced labial-palatal approximant
- ħ Voiceless epiglottal fricative
- ʕ Voiced epiglottal fricative
- ʕ Epiglottal plosive
- ʑ Alveolo-palatal fricatives
- ɻ Voiced alveolar lateral flap
- ɥ Simultaneous ʃ and x

Affricates and double articulations can be represented by two symbols joined by a tie bar if necessary.

kp̚ ts̚

SUPRASEGMENTALS

- ˈ Primary stress
- ˌ Secondary stress
- ː Long eː
- ˑ Half-long eˑ
- ˚ Extra-short e˚
- ◌̥ Minor (foot) group
- ◌̨ Major (intonation) group
- ◌̩ Syllable break ˌi.ækt
- ◌̯ Linking (absence of a break)

DIACRITICS Diacritics may be placed above a symbol with a descender, e.g. ɳ̰

◌̥ Voiceless	◌̥ n̥ d̥	◌̤ Breathy voiced	◌̤ ɳ̤ ɹ̤	◌̦ Dental	◌̦ ț d̦
◌̦ Voiced	◌̦ ɳ̦ ț	◌̨ Creaky voiced	◌̨ ɳ̨ ɹ̨	◌̩ Apical	◌̩ t̩ d̩
◌̨ Aspirated	◌̨ t̨ʰ d̨ʰ	◌̩ Linguolabial	◌̩ t̩ d̩	◌̪ Laminar	◌̪ t̪ d̪
◌̩ More rounded	◌̩ ɔ̩	◌̪ Labialized	◌̪ t̪ʷ d̪ʷ	◌̫ Nasalized	◌̫ ẽ
◌̪ Less rounded	◌̪ ɔ̪	◌̫ Palatalized	◌̫ t̫ʲ d̫ʲ	◌̬ Nasal release	◌̬ d̬ⁿ
◌̫ Advanced	◌̫ ɹ̫	◌̬ Velarized	◌̬ t̬ˠ d̬ˠ	◌̭ Lateral release	◌̭ ḓˡ
◌̬ Retracted	◌̬ ɛ̬	◌̭ Pharyngealized	◌̭ ṱˤ ḓˤ	◌̮ No audible release	◌̮ d̮̰
◌̭ Centralized	◌̭ ẽ	◌̮ Velarized or pharyngealized	◌̮ ɮ		
◌̮ Mid-centralized	◌̮ ẽ̮	◌̯ Raised	◌̯ ɛ̯ (ɹ̯ = voiced alveolar fricative)		
◌̯ Syllabic	◌̯ ɳ̯	◌̰ Lowered	◌̰ ɛ̰ (β̰ = voiced bilabial approximant)		
◌̰ Non-syllabic	◌̰ ɛ̰	◌̱ Advanced Tongue Root	◌̱ ɛ̱		
◌̱ Rhoticity	◌̱ ə̱ ɑ̱	◌̲ Retracted Tongue Root	◌̲ ɛ̲		

TONES AND WORD ACCENTS

- | LEVEL | CONTOUR |
|---------|------------------|
| ẽ̥ or ˩ | ↗ Extra high |
| é̥ or ˨ | ↘ High |
| ē̥ or ˥ | ↕ Mid |
| è̥ or ˧ | ↘ Low |
| ẽ̥ or ˩ | ↘ Extra low |
| ↓ | ↘ Downstep |
| ↑ | ↗ Upstep |
| ẽ̥ or ˩ | ↗ Rising |
| é̥ or ˨ | ↘ Falling |
| ē̥ or ˥ | ↗ High rising |
| è̥ or ˧ | ↘ Low rising |
| ẽ̥ or ˩ | ↗ Rising-falling |
| ↘ | ↗ Global rise |
| ↗ | ↘ Global fall |

APPENDIX B: PIANO MODELS

In the following chart the beam positions and the covered strings of various piano models are listed. On some piano models two types of crossbeams can be found. The ordinary crossbeams are located in between the strings and restrict, for instance, the execution of certain *glissandi* on the strings while additional crossbeams that connect the ordinary crossbeams restrict, for instance, the performance of certain vertical *glissandi*. Two ranges of covered strings are used here. The first range refers to strings that are completely covered by the bass strings and cannot be plucked at all. On some models these covered strings may alternatively be plucked in the rear end of the piano (*Steinway B-211, C-227, D-274* and *O-180*, all *Bechstein* models, *Yamaha C 3* and *Wendt & Lung 161*). The second range refers to the strings that are partially covered by the bass strings. They can be plucked *sul smorzatore*, but, for instance, certain harmonics cannot be fingered on them. All other strings are completely open (for the described techniques cf. the chapter on keyboard instruments). This list was produced with the friendly assistance of the *Bechstein* centre Berlin, the piano house *Goecke und Farenholtz* and the *Steinway* house Berlin. It mainly consists of recent piano models. The frames of historic piano models might vary.

Further, the listing by *Vaes*¹ is also presented here (except for the *Bösendorfer 200* and the *Steinway B* and *D* model because they are described by the other chart). However, it does not contain information about the covered strings. Further, in the case of the *Fazioli 278*, the listing contains a mistake². Therefore, this model is disregarded here.

¹ *Vaes, Extended*, pp. 1032-1048.

² The strings »c#1 – d²/C#4 – D5« are in *Vaes, Extended*, p. 1035 described as being adjacent to each other.

l = crossbeam [CB] = additional crossbeam

Model	Bechstein B 212
Beam positions	${}^2A - F\# [CB] G - c^2 c\#^2 - f\#^3 g^3 - c^5$ A0 - F#2 [CB] G2 - C5 C#5 - F#6 G6 - C8
Covered strings	G - G#/A (completely covered) A/A# - c ¹ (partially covered) G2 - G#2/A2 (completely covered) A2/A2# - C4 (partially covered)
Model	Bechstein C 234
Beam positions	${}^2A - E [CB] F - g\# a - c^2 c\#^2 - f\#^3 g^3 - c^5$ A0 - E2 [CB] F2 - G#3 A3 - C5 C#5 - F#6 G6 - C8
Covered strings	F - F#/G (completely covered) G/G# - e (partially covered) F2 - F#2/G2 (completely covered) G2/G#2 - E3 (partially covered)
Model	Bechstein D 282
Beam positions	${}^2A - C\# [CB] D - f\# g - c^2 c\#^2 - f\#^3 f\#^3 - c^5$ A0 - C#2 [CB] D2 - F#3 G3 - C5 C#5 - F#6 F#6 - C8
Covered strings	D - D#/E (completely covered) E/F# - e (partially covered) D2 - D#2/E2 (completely covered) E2/F#2 - E3 (partially covered)
Model	Bechstein L167 and M/P 192
Beam positions	${}^2A - A [CB] A\# - c^2 c\#^2 - f\#^3 g^3 - c^5$ A0 - A2 [CB] A#2 - C5 C#5 - F#6 G6 - C8
Covered strings	A# - H/c (completely covered) c/c# - d ¹ (partially covered) A#2 - B2/C3 (completely covered) C3/C#3 - D4 (partially covered)
Model	Bösendorfer 170
Beam positions	${}^2A - H [CB] c - a^1 a\#^1 - e^3 f^3 - c^5$ A0 - B2 [CB] C3 - A4 A#4 - E6 F6 - C8
Covered strings	c/c - c# (completely covered) c#/d - d# ¹ (partially covered) C3/C3 - C#3 (completely covered) C#3/D3 - D#4 (partially covered)
Model	Bösendorfer 200
Beam positions	${}^2A - A\# [CB] H - g\#^1 [CB] a^1 - d\#^3 e^3 - c^5$ A0 - A#2 [CB] B2 - G#4 [CB] A4 - D#6 E6 - C8
Covered strings	H (completely covered) c - c# ¹ (partially covered) B2 (completely covered) C3 - C#4 (partially covered)

Model	Bösendorfer 225
Beam positions	${}^2A - D\# [CB] E - g [CB] g\# - d^2 [CB] d\#^2 - f^3 f\#^3 - c^5$ $A0 - D\#2 [CB] E2 - G3 [CB] G\#3 - D5 [CB] D\#5 - F6 F\#6 - C8$
Covered strings	E/E – F (completely covered) F/F# – g (partially covered) E2/E2 – F2 (completely covered) F2/F#2 – G3 (partially covered)
Model	Boston GP-156 PE
Beam positions	${}^2A - A\# H - d^2 d\#^2 - g\#^3 a^3 - c^5$ $A0 - A\#2 B2 - D5 D\#5 - G\#6 A6 - C8$
Covered strings	H – c/c# (completely covered) c#/d – e ¹ (partially covered) B – C3/C#3 (completely covered) C#3/D3 – E4 (partially covered)
Model	Boston GP-163 and GP-163 PE
Beam positions	${}^2A - A\# H - d^2 d\#^2 - g\#^3 a^3 - c^5$ $A0 - A\#2 B2 - D5 D\#5 - G\#6 A6 - C8$
Covered strings	H – c/c# (completely covered) c#/d – d# ¹ (partially covered) B – C3/C#3 (completely covered) C#3/D3 – D#4 (partially covered)
Model	Boston GP-178 PE
Beam positions	${}^2A - A\# H - d^2 d\#^2 - g\#^3 a^3 - c^5$ $A0 - A\#2 B2 - D5 D\#5 - G\#6 A6 - C8$
Covered strings	H – c/c# (completely covered) c#/d – d ¹ (partially covered) B – C3/C#3 (completely covered) C#3/D3 – D4 (partially covered)
Model	Steinway B-211
Beam positions	${}^2A - E [CB] F - h^1 [CB] c^2 - e^3 f^3 - c^5$ $A0 - E2 [CB] F2 - B4 [CB] C5 - E6 F6 - C8$
Covered strings	F – F#/G (completely covered) G/G# – a# (partially covered) F2 – F#2/G2 (completely covered) G2/G#2 – A#3 (partially covered)
Model	Steinway C-227
Beam positions	${}^2A - E [CB] F - c^2 [CB] c\#^2 - f\#^3 g^3 - c^5$ $A0 - E2 [CB] F2 - C5 [CB] C\#5 - F\#6 G6 - C8$
Covered strings	F – F#/G (completely covered) G/G# – a (partially covered) F2 – F#2/G2 (completely covered) G2/G#2 – A3 (partially covered)

Model	Steinway D-274
Beam positions	${}^2A - E$ [CB] $F - c\#^2$ [CB] $d^2 - g^3$ $g\#^3 - c^5$ A0 – E2 [CB] F2 – C#5 [CB] D5 – G6 G#6 – C8
Covered strings	F – F#/G (completely covered) G/G# – g (partially covered) F2 – F#2/G2 (completely covered) G2/G#2 – G3 (partially covered)
Model	Steinway O-180 and S-155
Beam positions	${}^2A - A\#$ H – c^2 $c\#^2 - f\#^3$ $g^3 - c^5$ A0 – A#2 B2 – C5 C#5 – F#6 G6 – C8
Covered strings	H – c/c# (completely covered) c#/d – c ¹ (partially covered) B2 – C3/C#3 (completely covered) C#3/D3 – C4 (partially covered)
Model	Wendt & Lung 161
Beam positions	${}^2A - A\#$ [CB] H – $c\#^2$ $d^2 - g^3$ $g\#^3 - c^5$ A0 – A#2 [CB] B2 – C#5 D5 – G6 G#6 – C8
Covered strings	H – c/c# (completely covered) c#/d – g# ¹ (partially covered) B2 – C3/C#3 (completely covered) C#3/D3 – G#4 (partially covered)
Model	Yamaha C3
Beam positions	${}^2A - A\#$ H – d^2 $d\#^2 - g^3$ $g\#^3 - c^5$ A0 – A#2 B2 – D5 D#5 – G6 G#6 – C8
Covered strings	H – c/c# (completely covered) c#/d – d# ¹ (partially covered) B2 – C3/C#3 (completely covered) C#3/D3 – D#4 (partially covered)

Vaes:

Model	Bechstein B-88 (208 cm)
Beam positions	${}^2A - A$ [CB] $A\# - c^2$ $c\#^2 - f\#^3$ $g^3 - c^5$ A0 – A2 [CB] A#2 – C5 C#5 – F#6 G6 – C8
Model	Fazioli 183
Beam positions	${}^2A - c\#$ [CB] $d - g\#^1$ [CB] $a^1 - d\#^3$ $e^3 - c^5$ A0 – C#3 [CB] D3 – G#4 [CB] A4 – D#6 E6 – C8
Model	Fazioli 212
Beam positions	${}^2A - F\#$ [CB] $G\# - g\#^1$ $a^1 - d\#^3$ $e^3 - c^5$ A0 – F#2 [CB] G#2 – G#4 A4 – D#6 E6 – C8

Model	Fazioli 228
Beam positions	${}^2A - F\# [CB] \mid G - f\#^1 \mid g^1 - d\#^3 \mid e^3 - c^5$ A0 – F#2 [CB] G2 – F#4 G4 – D#6 E6 – C8
Model	Fazioli 308
Beam positions	${}^2A - D\# [CB] \mid E - h^1 [CB] \mid c^2 - f^3 \mid f\#^3 - c^5$ A0 – D#2 [CB] E2 – B4 [CB] C5 – F6 F#6 – C8
Model	Kawai RX-3
Beam positions	${}^2A - E [CB] \mid F - e^1 \mid f^1 - d^3 \mid d\#^3 - c^5$ A0 – E2 [CB] F2 – E4 F4 – D6 D#6 – C8
Model	Kawai RX-5
Beam positions	${}^2A - E [CB] \mid F - e^1 \mid f^1 - d^3 \mid d\#^3 - c^5$ A0 – E2 [CB] F2 – E4 F4 – D6 D#6 – C8
Model	Seiler 242
Beam positions	${}^2A - F\# [CB] \mid G - a\#^1 \mid h^1 - f\#^3 \mid g^3 - c^5$ A0 – F#2 [CB] G2 – A#4 B4 – F#6 G6 – C8
Model	Yamaha C2
Beam positions	${}^2A - A\# [CB] \mid H - d^2 \mid d\#^2 - g^3 \mid g\#^3 - c^5$ A0 – A#2 [CB] B2 – D5 D#5 – G6 G#6 – C8
Model	Yamaha C6 and S6
Beam positions	${}^2A - G [CB] \mid G\# - a\#^1 \mid h^1 - f\#^3 \mid g^3 - c^5$ A0 – G2 [CB] G#2 – A#4 B4 – F#6 G6 – C8
Model	Yamaha C7
Beam positions	${}^2A - E [CB] \mid F - a\#^1 \mid h^1 - f\#^3 \mid g^3 - c^5$ A0 – E2 [CB] F2 – A#4 B4 – F#6 G6 – C8
Model	Yamaha CFIIIS
Beam positions	${}^2A - E [CB] \mid F - g \mid g\# - c\#^2 \mid d^2 - g^3 \mid g\#^3 - c^5$ A0 – E2 [CB] F2 – G3 G#3 – C#5 D5 – G5 G#6 – C8

APPENDIX C: SCORES AND RECORDINGS ON THE CD

1. Scores

No. 1 Tatsachen in zwei Sätzen. For violin alone.

No. 2 Entgleisungen. For flute, B \flat clarinet, piano, percussion, violin and violincello.

No. 3 Zu vier Händen – Interventionen für Konzertflügel. For piano and assistance.

No. 4 Ausführung über den Materialbegriff. For B \flat clarinet, mezzo-soprano, contrabass and electronics.

No. 6 Klanggruppen. For violincello alone.

No. 7 Filterspiel – Music for conferences. For 4 percussionists, 4 assistants, 4 interpreter's booths and electronics.

No. 8 Three songs. For two guitarists.

2. Recordings

No. 1 Tatsachen in zwei Sätzen. For violin alone. Premiered in 2010 at the DESY-institute/Hamburg. Violinist: Eugene Nakamura.

No. 6 Klanggruppen. For violincello alone. Premiered in 2012 at the 'Laeiszhalle'/Hamburg. Cellist: Saerom Park Foucher.

APPENDIX D: RECORD OF ACTIVITIES

Seminars

Mare 500/521 research skills workshop programme (2010-2011).

Presentations

Electroacoustic music notation. Postgraduate research seminar, University of Plymouth (03/2011).

The techniques of string instruments. Postgraduate research seminar, University of Plymouth (12/2011).

The techniques of percussion instruments. Postgraduate research seminar, University of Plymouth (03/2012).

Klanggruppen: a composition for violincello. Postgraduate research seminar, University of Plymouth (10/2012).

Compositions and concerts

Please refer to 'Appendix C' for a detailed list.

Publications

An extended version of this thesis, including chapters on vocal techniques and electroacoustic music, will be published in 2013 by the LIT press.

Awards

Special award *Klangradar 3000* of the *Tonali* composition competition 2012 for 'Klanggruppen'.

LIST OF REFERENCES

1. Books

1999 Ernst von Siemens Musikpreis [1999 Ernst von Siemens Music Prize]. Arditti Quartett [Arditti Quartet]. Edited by the Ernst von Siemens Foundation. Zug 1999.

Adler, Samuel: The study of orchestration. 3rd edition. New York and London 2002.

Bartolozzi, Bruno: Neue Klänge für Holzblasinstrumente [New sounds for woodwinds]. Mainz 1971.

Beal, Amy C.: New Music, new allies. American experimental music in West Germany from the zero hour to the reunification. Berkeley et al. 2006.

Boehmer, Konrad: Zur Theorie der offenen Form in der Neuen Musik [On the open form theory in New Music]. Darmstadt 1967.

Boulez, Pierre: Preface. In: Pascal Gallois. The techniques of bassoon playing. Kassel et al. 2009, p. 7.

Brasseur, Lee: Visualizing technical information. A cultural critique. New York 2003.

Dahlhaus, Carl: Notenschrift heute [Notation today]. In: Ernst Thomas (ed.): Notation Neuer Musik [Notation of New Music]. Darmstädter Beiträge zur Neuen Musik IX [Darmstadt's contributions to New Music IX]. Mainz 1965, pp. 9-34.

Dick, Robert: Neuer Klang durch neue Technik [Tone development through extended techniques]. Frankfurt/M. 1992.

Feldman, Morton: Slee Lecture, February 2, 1973. Baird Hall, University at Buffalo, The State University of New York. Transcription by Nicola Walker-Smith. No city named 2001.

Finscher, Ludwig (ed.): Die Musik in Geschichte und Gegenwart [Music in the past and present]. Personenteil 6 [Persons, part 6]. Kassel et al. 2001.

Gallois, Pascal. The techniques of bassoon playing. Kassel et al. 2009.

Haubenstock-Ramati, Roman: Notation – Material und Form [Notation – material and form]. In: Ernst Thomas (ed.): Notation Neuer Musik [Notation of New Music]. Darmstädter Beiträge zur Neuen Musik IX [Darmstadt's contributions to New Music IX]. Mainz 1965, pp. 51-54.

Hermann, Matthias: Weiterentwicklung des Serialismus [Further development of serialism]. Aleatorik [Aleatory]. Reaktionen auf den Serialismus [Reactions to serialism]. Postserielle Konzepte [Post-serial concepts]. Stuttgart 2002.

Hilberg, Frank: David Tudors Konzept des ‘elektrifizierten Klaviers’ und seine Interpretation von John Cages ‘Variations II’ (1961) [David Tudor’s concept of the ‘electrified piano’ and his interpretation of John Cage’s ‘Variations II’ (1961)]. Saarbrücken 1996.

Hilberg, Frank: Geräusche? [Noises?] In: Ulrich Tadday (ed.): Helmut Lachenmann. Munich 2009, pp. 60-75.

Karkoschka, Erhard: Notation in New Music. A critical guide to interpretation and realisation. Translation by Ruth Koenig. 1st published in German 1966. New York and Washington 1972.

Kientzy, Daniel: Les sons multiples aux saxophones [Multiphonics on saxophones]. For sopranino, soprano, alto, tenor and baritone saxophones. Paris 1982.

Krassnitzer, Gerhard: Multiphonics für Klarinette mit deutschem System und andere erweiterte Spieltechniken [Multiphonics for clarinets with German system and other contemporary playing techniques]. Aachen 2002.

Kremer, Gidon: Obertöne [Overtones]. 3rd edition. Salzburg and Vienna 1977.

Lachenmann, Helmut: Musik als existentielle Erfahrung [Music as existential experience]. Schriften 1966-1995 [Writings 1966-1995]. Wiesbaden 1996.

Levine, Carin and **Mitropoulos-Bott**, Christina: The techniques of flute playing. Kassel et al. 2002.

Levine, Carin and **Mitropoulos-Bott**, Christina: The techniques of flute playing II. Piccolo, alto and bass flute. Kassel et al. 2004.

Ligeti, György: Neue Notation – Kommunikationsmittel oder Selbstzweck? [New notation – medium of communication or self purpose?] In: Ernst Thomas (ed.): Notation Neuer Musik [Notation of New Music]. Darmstädter Beiträge zur Neuen Musik IX [Darmstadt’s contributions to New Music IX]. Mainz 1965, pp. 35-50.

Manning, Peter: Electronic and Computer Music. Oxford 1985.

Motz, Wolfgang: Konstruktion und Ausdruck [Construction and expression]. Analytische Betrachtungen zu Il canto sospeso (1955/56) von Luigi Nono [Analytical examinations of Luigi Nono's Il canto sospeso (1955/56)]. Saarbrücken 1996.

Nonnenmann, Rainer: Angebot durch Verweigerung [Offerings by denial]. Die Ästhetik instrumentalkonkreten Komponierens in Helmut Lachenmanns frühen Orchesterwerken [The aesthetic of instrumental-concrete composition in Helmut Lachenmann's early orchestral works], Mainz et al. 2000.

Pâris, Alain: Klassische Musik im 20. Jahrhundert [Classical music in the 20th century]. 2nd extended, completely revised edition. Munich 1997.

Pompino-Marschall, Bernd: Einführung in die Phonetik [Introduction to phonetics]. 2nd revised and extended edition. Berlin and New York 2003.

Read, Gardner: Contemporary instrumental techniques New York and London 1976.

Rehfeldt, Phillip: New directions for clarinet. Los Angeles and London 1977.

Risatti, Howard: New music vocabulary. A guide to notational signs for contemporary music. Chicago and London 1975.

Roggenkamp, Peter: Schriftbild und Interpretation in neuer Klaviermusik [Type face and interpretation in new piano music]. Vienna 1996.

Sadie, Stanley (ed.): The new Grove dictionary of music and musicians, vol. 20. 2nd edition. No city named 2001.

Schaeffer, Pierre: Musique concrète. Translated by Josef Häusler. Stuttgart 1974.

Schick, Steven: The percussionist's art. Same bed, different dreams. Rochester 2006.

Sevsay, Ertuğrul: Handbuch der Instrumentationspraxis [Handbook of instrumentation practice]. Kassel et al. 2005.

Stone, Kurt: Music notation in the twentieth century. New York and London 1980.

Tadday, Ulrich (ed.): Helmut Lachenmann. Munich 2009.

Thomas, Ernst (ed.): Notation Neuer Musik [Notation of New Music]. Darmstädter Beiträge zur Neuen Musik IX [Darmstadt's contributions to New Music IX]. Mainz 1965.

Vaes, Luk: Extended piano techniques. In theory, history and performance practice. No city named 2009.

Veale, Peter et al.: The techniques of oboe playing. Kassel et al. 1994.

Weiss, Marcus and **Netti**, Giorgio: The techniques of saxophone playing. Kassel et al. 2010.

Wittgenstein, Ludwig: Tractatus logico-philosophicus. Translated by D. F. Pears and B. F. McGuinness. Reprinted with corrections. London et al. 1972.

Xenakis, Iannis: Formalized music. Thought and mathematics in composition. Bloomington and London 1972.

2. Journals and articles

Chen, Jer-Ming et al.: Pitch bending and glissandi on the clarinet. Roles of the vocal tract and partial tone hole closure. In: Journal of the Acoustic Society of America, vol. 126(3). No city named 2009, pp. 1511-1520.

Goebels, Franzpeter: Gestalt und Gestaltung musikalischer Grafik [Shape and design of musical graphics]. In: Melos. Zeitschrift für Neue Musik [Journal for New Music]. Mainz 1972, pp. 23-34.

Joe, Jeongwohn and **Song**, S. Hoon: Roland Barthes' 'text' and aleatoric music: is the 'birth of the reader' the birth of the listener? In: Muzikologija 2, issue 2. No city named 2002, pp. 263-281.

Journal of the Acoustic Society of America, vol. 126(3). No city named 2009.

Melos. Zeitschrift für Neue Musik [Journal for New Music]. Mainz 1972.

Muzikologija 2, issue 2. No city named 2002.

3. Scores and musical works

Alsina, Carlos Roqué: Consecuencia. Trombone solo. Berlin and Wiesbaden 1969.

Berio, Luciano: Gesti. For alto recorder. London 1970.

Berio, Luciano: Sequenza II. For harp alone. London 1965.

Berio, Luciano: Sequenza VIII. For violin alone. Milan 1977.

Berio, Luciano: Sequenza X. For C trumpet (and resonances of a grand piano). Milan 1984.

Berio, Luciano: Sequenza XI. For guitar alone.

Berio, Luciano: Sequenza XII. For bassoon alone. Vienna 1988.

Boulez, Pierre: Improvisation II sur mallarme. For soprano and 9 instrumentalists. London 1958.

Boulez, Pierre: Notation I-IV. For orchestra. London 1978.

Brahms, Johannes: Hungarian dances I and II. For piano four hands. Mainz and Leipzig no year named [ca. 1920].

Braun, Gerhard: Tuba - Tabu. For tuba solo. Bad Schwalbach 2004.

Brouwer, Leo: Elogio de la danza. For guitar. London et al. 1972.

Brouwer, Leo: La espiral eterna. For guitar. Mainz 1973.

Brouwer, Leo: Obras para guitarra. Cuaderno I. Cuba 1982.

Brown, Earle: December 1952. For one or more instruments and/or sound-producing media. In: Earle Brown: Folio and 4 systems. New York 1961, no page named.

Brown, Earle: Folio and 4 Systems. New York 1961.

Cage, John: First construction (in metal). Percussion sextet with assistant. New York 1962.

Cage, John: Imaginary landscape no. 1. For records of constant and variable frequency, large Chinese cymbal and string piano. New York 1960.

Cage, John: In the name of the Holocaust. Music for the dance by Merce Cunningham. In: John Cage: Prepared piano music. Volume 1. 1940-47. New York et al. 1960, pp. 25-29.

Cage, John: Music of changes II. New York 1961.

Cage, John: Music of changes III. For piano. New York et al. 1961.

Cage, John: Prepared piano music. Volume 1. 1940-47. New York et al. 1960.

Cage, John: Prepared piano music. Volume 2. 1940-47. New York et al. 1960.

- Cerha**, Friedrich: Enjambement. [For flute, violin, percussion, trumpet, trombone and double-bass]. Vienna 1963.
- Cervetti**, Sergio: Zinctum. For string quartet. Celle 1969.
- Cowell**, Henry: The piano music of Henry Cowell. Volume two. New York and London 1982.
- Cowell**, Henry: Vestiges. In: Henry Cowell: The piano music of Henry Cowell. Volume two. New York and London 1982, pp. 3-6.
- Crumb**, George: Ancient voices of children. Soprano, boy soprano, oboe, mandolin, harp, electric piano, percussion. New York et al. 1970.
- Crumb**, George: Echoes of time and the river. Four processions for orchestra. New York 1986.
- Crumb**, George: Mundus canis ("A dog's world"). Guitar and percussion. New York et al. 2000.
- Delás**, José Luis: Outremer clair et foncé. In: Alfons Kontarsky (ed.): Pro musica nova. Studies for playing avant-garde music. For piano. Cologne 1972, pp. 30-33.
- Dittrich**, Paul-Heinz: – the – m –. For bassoon solo and live-electronics based on an epigram by e. e. cummings. In: Dieter Hähnchen (ed.): Zeitgenössische Musik für Fagott solo [Contemporary music for bassoon alone]. Leipzig 1986, pp. 19-33.
- Dittrich**, Paul-Heinz: Streichquartett III. Nacht-Musik. Wiesbaden et al. 1995.
- Eloy**, Jean-Claude: Equivalences. For 18 instrumentalists. Paris 1965.
- Essl**, Karlheinz: Sequitur XII. For harpsichord and live-electronics. No city named 2009.
- Ferneyhough**, Brian: Incipits. Solo viola, percussion and six instruments. London et al. 2002.
- Ferneyhough**, Brian: Mnemosyne. Bass flute and pre-recorded tape. London et al. 1996.
- Ferneyhough**, Brian: Terrain. Solo violin and chamber ensemble. London et al. 1993.
- Ferneyhough**, Brian: Third string quartet. London et al. 1988.

Foss, Lukas: *Echoi*. For four soloists. Clarinet, cello, percussion, and piano. New York and Mainz 1964.

Furrer, Beat: *Spur*. For string quartet and piano. Kassel 1998.

Gaber, Harley: *Voce II*. Female voice, alto flute, and percussion. Cincinnati 1967.

Gubaidulina, Sofia: *Dots, lines and zigzag*. For bass clarinet and piano. Hamburg 1995.

Hähnchen, Dieter (ed.): *Zeitgenössische Musik für Fagott solo* [Contemporary music for bassoon alone]. Leipzig 1986.

Halffter, Cristobal: *Lineas y puntos*. For 20 instruments, 2 loudspeakers and tape. London 1967.

Halffter, Cristobal: *Noche pasiva del sentido (San Juan de la Cruz)*. For soprano, percussion and electronics. London 1973.

Haubenstock-Ramati, Roman: *Séquences*. Music for violin and orchestra. London 1961.

Henze, Hans Werner: *4th string quartet*. Mainz 1976.

Henze, Hans Werner: *Sinfonia N. 6*. For two chamber orchestras. Mainz 1970.

Holliger, Heinz: *Duo II*. For violin and violincello. Mainz et al. 2005.

Holliger, Heinz: *Partita*. For piano. Mainz et al. 2003.

Holliger, Heinz: *Partita (II)*. For harp. Mainz 2004.

Holliger, Heinz: *Pneuma*. For wind, percussion, organ and radios. Mainz 1972.

Holliger, Heinz: *Siebengesang*. For oboe, orchestra, singing voices and loudspeaker. Mainz 1969.

Holliger, Heinz: *Sonate (in)solit(air)e*. For flute solo. Mainz et al. 1998.

Holliger, Heinz: *Three pieces*. For bassoon solo. Mainz 2002.

Holliger, Heinz: *Vier Lieder ohne Worte*. Mainz 1987.

Hosokawa, Toshio: *Sen I*. For flute. Mainz et al. 1993.

Kagel, Mauricio: *..., den 24. xii. 1931*. Garbled messages for baritone and instruments. Frankfurt/M. et al. 1995.

- Kagel**, Mauricio: Anagrama. For four solo singers, speaking choir and chamber ensemble. London 1965.
- Kagel**, Mauricio: Atem. For a wind instrumentalist. London 1976.
- Kagel**, Mauricio: Die Stücke der Windrose. Norden. For salon orchestra. Frankfurt/M. et al. 1966.
- Kagel**, Mauricio: Dressur. Drum trio for wood instruments. Frankfurt/M. et al. 1983.
- Kagel**, Mauricio: Fürst Igor, Strawinsky. For bass voice and instruments. Frankfurt/M. et al. 1988.
- Kagel**, Mauricio: Heterophonie. For orchestra. Frankfurt/M. et al. 1969.
- Kagel**, Mauricio: L'art bruit. Solo for two. Frankfurt/M. et al. 1998.
- Kagel**, Mauricio: Match. For three players. London 1967.
- Kagel**, Mauricio: Passé composé. Frankfurt/M. et al. 1996.
- Kagel**, Mauricio: Schattenklänge. Three pieces for bass clarinet. Frankfurt/M. et al. 1997.
- Kagel**, Mauricio: Sonant (1969/....). For guitar, harp, double bass and membranophones. Frankfurt/M. et al. 1964.
- Kagel**, Mauricio: Staatstheater. Scenic composition. London 1971.
- Kagel**, Mauricio: Streichquartett I/II. London 1974.
- Kagel**, Mauricio: Transición II. For piano, percussion and two magnetic tapes. London 1963.
- Katzer**, Georg: Dialog imaginär. For flute and tape. In: Werner Tast (ed.): Zeitgenössische Musik für Flöte solo [Contemporary music for flute alone]. Leipzig 1987, piece no. 8.
- Kelemen**, Milko: Changeant. For violincello and orchestra. Frankfurt/M. et al. 1969.
- Koch-Raphael**, Erwin: Spuren. Tenor trombone solo with optional percussion. Berlin and Wiesbaden 1980.
- König**, Gottfried Michael: Essay. Composition for electronic sounds. Vienna 1960.

Köszeghy, Pèter: Mortualium (coins for Charon). For ensemble. No city named [Berlin] 2008.

Kontarsky, Alfons (ed.): Pro musica nova. Studies for playing avant-garde music. For piano. Cologne 1972.

Kotoński, Włodozmierz: A battere. For percussion, guitar, harpsichord, viola and violincello. Celle 1963.

Lachenmann, Helmut: „... zwei Gefühle ...“, Musik mit Leonardo. For speakers and ensemble. Wiesbaden et al. 2002.

Lachenmann, Helmut: Accanto. Music for a clarinetist with orchestra. Wiesbaden 1984.

Lachenmann, Helmut: Air. Music for large orchestra and percussion-solo. Revised edition. Wiesbaden et al. 1994.

Lachenmann, Helmut: Allegro sostenuto. For clarinet, bass clarinet in B, violincello and piano. Wiesbaden et al. 2003.

Lachenmann, Helmut: Dal niente (Interieur III). For a solo clarinet-player. Cologne 1974.

Lachenmann, Helmut: Gran torso. Music for string quartet. Wiesbaden 1972.

Lachenmann, Helmut: Guero. For piano. Wiesbaden 1972.

Lachenmann, Helmut: Klangschatten – mein Saitenspiel. For 48 strings and 3 grand pianos. Cologne 1978.

Lachenmann, Helmut: Mouvement (– vor der Erstarrung). For ensemble. Wiesbaden 1985.

Lachenmann, Helmut: NUN. Music for flute, trombone, male voices and orchestra. Wiesbaden 2002.

Lachenmann, Helmut: Pression. For one cellist. Cologne 1972.

Lachenmann, Helmut: Salut für Caudwell. For two guitarists. Wiesbaden 1985.

Lachenmann, Helmut: Staub. For orchestra. Wiesbaden et al. 1997.

Lachenmann, Helmut: temA. For flute, voice (mezzo-soprano) and violincello. Cologne 1971.

- Lachenmann**, Helmut: Toccata. Study for violin alone. Wiesbaden et al. 2006.
- Lehmann**, Hans Ulrich: Arco. In: Eckart Schloifer (ed.): Pro musica nova. Studies for playing contemporary music. For violin. Wiesbaden 1986, pp. 27-31.
- Leidel**, Wolf-G.: Drei Aperçus. For bassoon. In: Dieter Hähnchen (ed.): Zeitgenössische Musik für Fagott solo [Contemporary music for bassoon alone]. Leipzig 1986, p. 54a.
- Ligeti**, György: Apparitions. For orchestra. 2nd revised edition. Vienna 1971.
- Ligeti**, György: Aventures. For three singers and seven instrumentalists. Frankfurt/M. et al. 1964.
- Ligeti**, György: Etudes pour piano. Premier livre. Mainz et al. 1986.
- Ligeti**, György: Requiem. For soprano solo, two mixed choruses and orchestra. Frankfurt/M. et al. 1965.
- Logothetis**, Anestis: Styx. Composition for any combination of instruments. Cologne 1972.
- Maderna**, Bruno: Widmung. For violin alone. Milan 1976.
- Matsuoka**, Takashi: Pietà. For flute alone. Tokyo 1989.
- Messiaen**, Olivier: Des canyons aux étoiles... Troisième partie. For solo piano, horn, xyloimba, glockenspiel and orchestra. Paris 1978.
- Michael**, Frank: Epigramme. For trombone alone. Berlin 1982.
- Michael**, Frank: Invocations. For flute alone. Berlin and Wiesbaden 1979.
- Moran**, Robert: Four visions. For flute, harp and string quartet. London 1974.
- Nono**, Luigi: A Pierre. Dell'azzurro silenzio, inquietum. For contrabass flute in G, contrabass flute in B flat and live-electronics. Final version. No city named [Italy] 1996.
- Nono**, Luigi: Composizione per orchestra nr. 2. Diario polacco '58. Mainz 1959.
- Nono**, Luigi: Con Luigi Dallapiccola. For 6 percussion players and live-electronics. Milan 1979.
- Nono**, Luigi: Das atmende Klarsein. For small chorus, bass flute, live electronics and magnetic tape. Milan 2005.

Nono, Luigi: *Il canto sospeso*. For soprano, contralto, and tenor soli, mixed chorus and orchestra. London et al. 1957.

Nono, Luigi: *Fragmente-Stille, an Diotima*. For string quartet. Milan 1980.

Nono, Luigi: *La lontananza nostalgica utopica futura*. For solo violin, 8 magnetic tapes and 8 to 10 music stands. Milan 1988.

Nono, Luigi: *Prometeo, tragedia dell'ascolto*. For singers, speakers, chorus, solo strings, solo winds, glasses, orchstral groups and live electronics. Booklet, recording 2003. No city named [Vienna] 2007.

Pagh-Paan, Younghi: *Dreisam-Nore*. For flute alone. Munich et al. 1980.

Penderecki, Krzysztof: *Capriccio*. For oboe and 11 strings. Celle and Kraków 1968.

Penderecki, Krzysztof: *Fluorescences*. For orchestra. Celle 1962.

Penderecki, Krzysztof: *Threnody. To the victims of Hiroshima*. For 52 strings. London et al. 1961.

Pousseur, Henri: *Caractères 1a, 1b*. Piano solo. Vienna 1962.

Pröve, Bernfried: *Firebird*. For violin alone. Celle 1993.

Redel, Martin: *Musik für Klavier und Schlaginstrumente*. Berlin and Wiesbaden 1970.

Redel, Martin: *Rounds*. For percussion solo. Berlin and Wiesbaden 1979.

Saariaho, Kaija: *Laconisme de l'aile*. For flute solo with optional electronics. No city and year named [Helsinki 2002].

Salzedo, Carlos: *Modern study of the harp. General survey of the instrument, with five poetical studies for the harp alone*. New York 1921.

Schloifer, Eckart (ed.): *Pro musica nova. Studies for playing contemporary music*. For violin. Wiesbaden 1986.

Schönberg, Arnold: *Drei Klavierstücke [Three piano pieces]*. Los Angeles 1910.

Schönberg, Arnold: *Two songs for voice and piano. I. Gedenken. II. Am Strande*. Los Angeles 1966.

Sciarrino, Salvatore: *I Sonata*. For grand piano. Milan 1977. In: *Cinque sonate*. For grand piano. Milan 1997, pp. 1-54.

Sciarrino, Salvatore: All'aure in una lontanza. For G flute (or C flute or bass flute). In: Salvatore Sciarrino: L'opera per flauto. Milan 1990, pp. 3-6.

Sciarrino, Salvatore: Cinque sonate. For grand piano. Milan 1997.

Sciarrino, Salvatore: Il giardino di Sara. For voice and five performers. Rome and Milan, 2009.

Sciarrino, Salvatore: L'opera per flauto. Milan 1990.

Sciarrino, Salvatore: Sonatina. For violin and grand piano. Milan 1975.

Serocki, Kazimierz: Segmenti. For chamber orchestra. Celle 1962.

Serocki, Kazimierz: Swinging music. For clarinet, trombone, cello (or double bass), and piano. Celle 1971.

Sotelo, Mauricio: Del aura al suspira. For contrabass flute (or alto flute) and sound carrier. Vienna 2001.

Stockhausen, Karlheinz. Klavierstück V. London 1965.

Stockhausen, Karlheinz: Klavierstück VI. London 1965.

Stockhausen, Karlheinz: Klavierstück XII. Examen von Donnerstag aus Licht. As a piano solo. Kürten 1983.

Stockhausen, Karlheinz: Klavierstück XI. 8th edition. London 1998.

Stockhausen, Karlheinz: Kontakte. For electronic sounds, piano and percussion. London 1966.

Stockhausen, Karlheinz: Kontra-Punkte. For ten instruments. London 1953.

Stockhausen, Karlheinz: Luzifers Traum oder Klavierstück XIII. As a piano solo. Kürten 1982.

Stockhausen, Karlheinz: Mikrophonie I. For tamtam, 2 microphones, 2 filters and controller. London 1964.

Stockhausen, Karlheinz: Punkte. For orchestra. London 1966.

Stockhausen, Karlheinz. Zyklus. For one percussionist. London 1961.

Szalonek, Witold: Concertino. For flute and chamber orchestra. Warsaw 1965.

Szalonek, Witold: Piernikiana. For tube solo. Kraków and Munich 1978.

Szalonek, Witold: Proporzioni II. For flute, violincello and grand piano (or harp). Kraków 1971.

Tast, Werner (ed.): Zeitgenössische Musik für Flöte solo [Contemporary music for flute alone]. Leipzig 1987.

Varèse, Edgard: Amériques. Performance edition prepared from the original manuscript by Chou Wen-chung. San Giuliano Milanese 1997.

Varèse, Edgard: Density 21.5. For flute alone. New York 1966.

Varèse, Edgard: Déserts. For 15 instruments, percussion and tape. Milan 2000.

Varèse, Edgard: Hyperprism. For small orchestra and percussion. New York 1966.

Varèse, Edgard: Ionisation. For percussion ensemble of 13 players. New York 1958.

Varèse, Edgard: Intégrales. For small orchestra and percussion. No city named 1926.

Varèse, Edgard: Offrandes. For soprano and chamber orchestra. New York 1927.

Xenakis, Iannis: Dmaathen. For oboe and percussion soloists. Paris 1976.

Xenakis, Iannis: Linaia – Agon. For horn, trombone and tuba. Paris 1972.

Xenakis, Iannis: Rebonds. Paris 1991.

Xenakis, Iannis: ST/4-1,080262. String quartet. London et al. 1967.

Zimmermann, Bernd Alois: Canto di speranza. Mainz 1958.