

Ort: Berlinger, Fiel
Achsiedlung: Wohnen in der Raumstadt
Projektprogramm
Bregenz, März 2008

Die Pavillons sind im Rahmen eines Workshops im Westend am Samstag und Sonntag den 8. und 9. März 2008 entstanden.

Wohnungsverstärkung

Aussenaufnahme

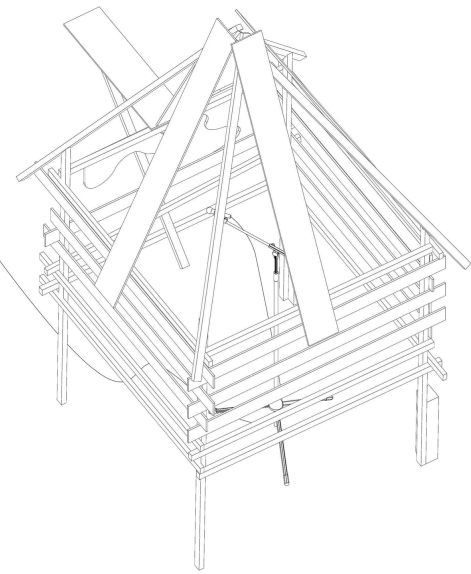

13

Pavillon 2

Pavillon 3

Pavillon 1

Atrium

Pavillon 4

Pavillon 5

**INHABITING THE SPATIAL CITY:
SCHEME OF INTERVENTION**

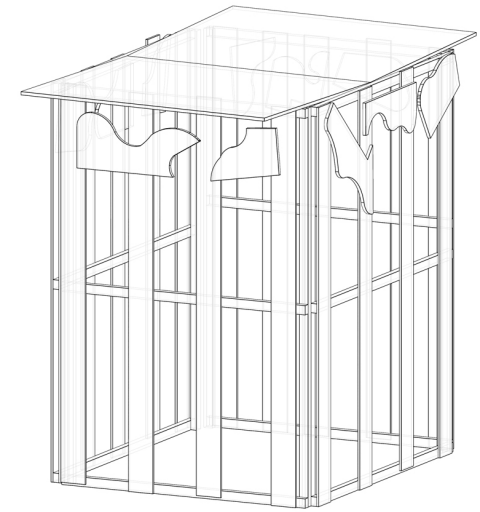
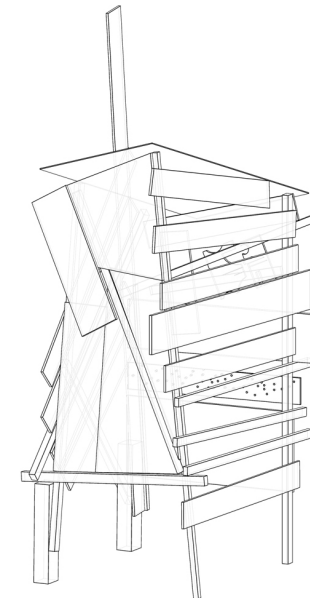
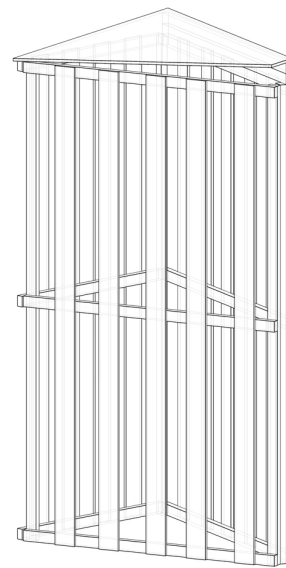
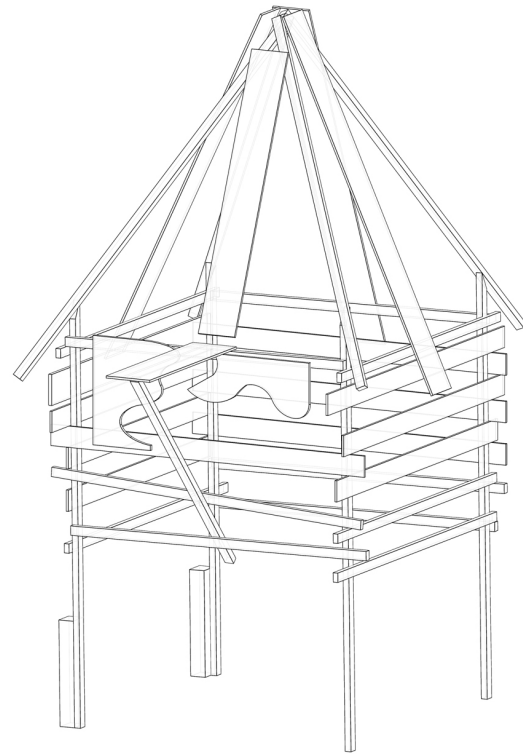
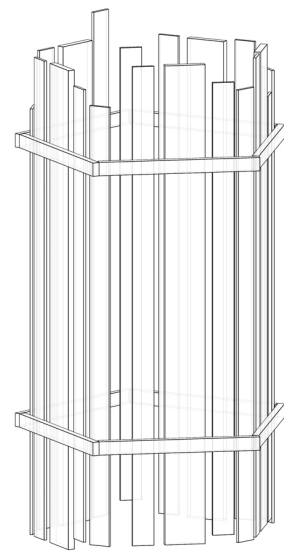

**INHABITING THE SPATIAL CITY:
PAVILIONS, ISOMETRIC DRAWING**



**MOBILE UNIT:
ROAD TRANSPORT**

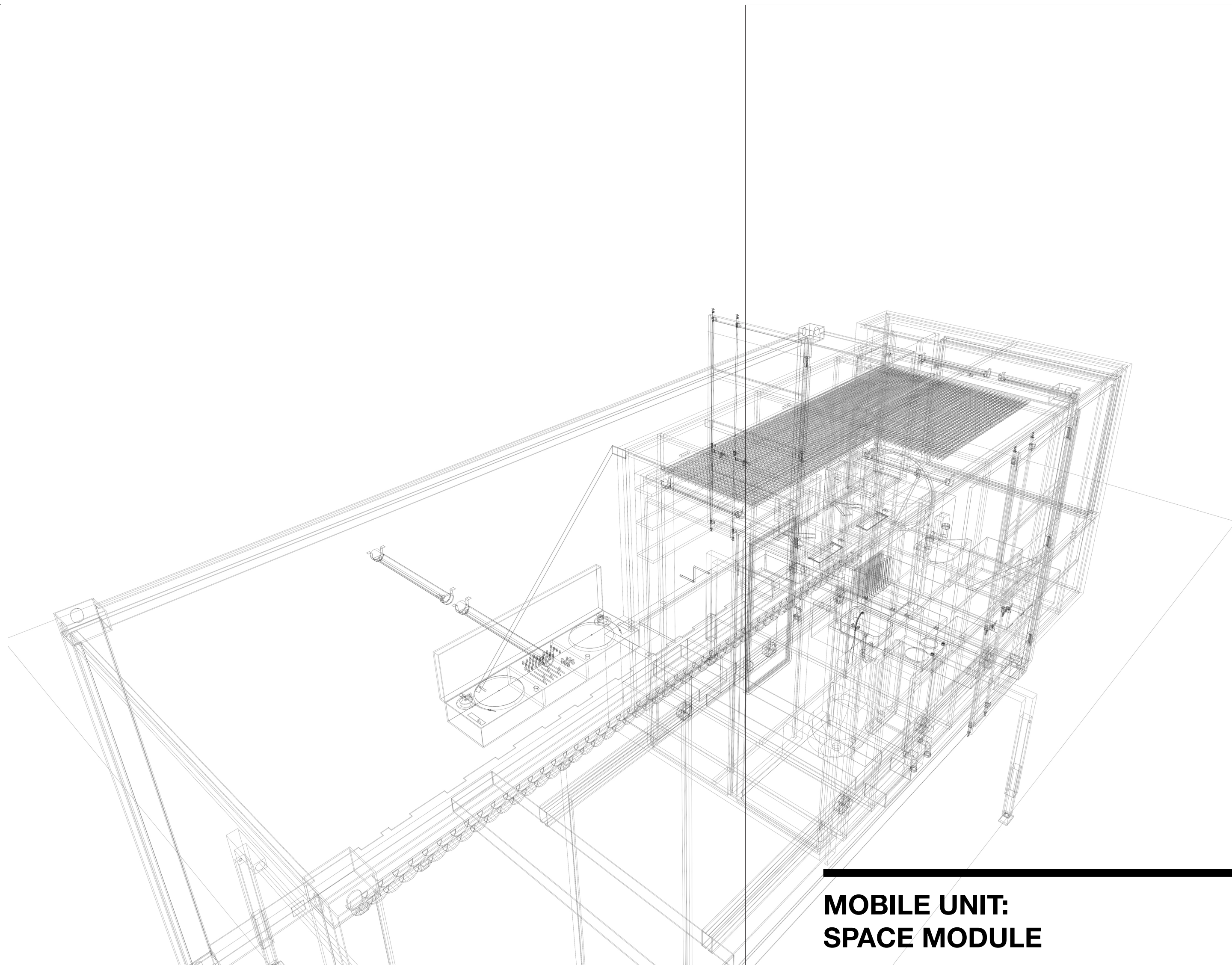

**MOBILE UNIT:
SPACE MODULE**

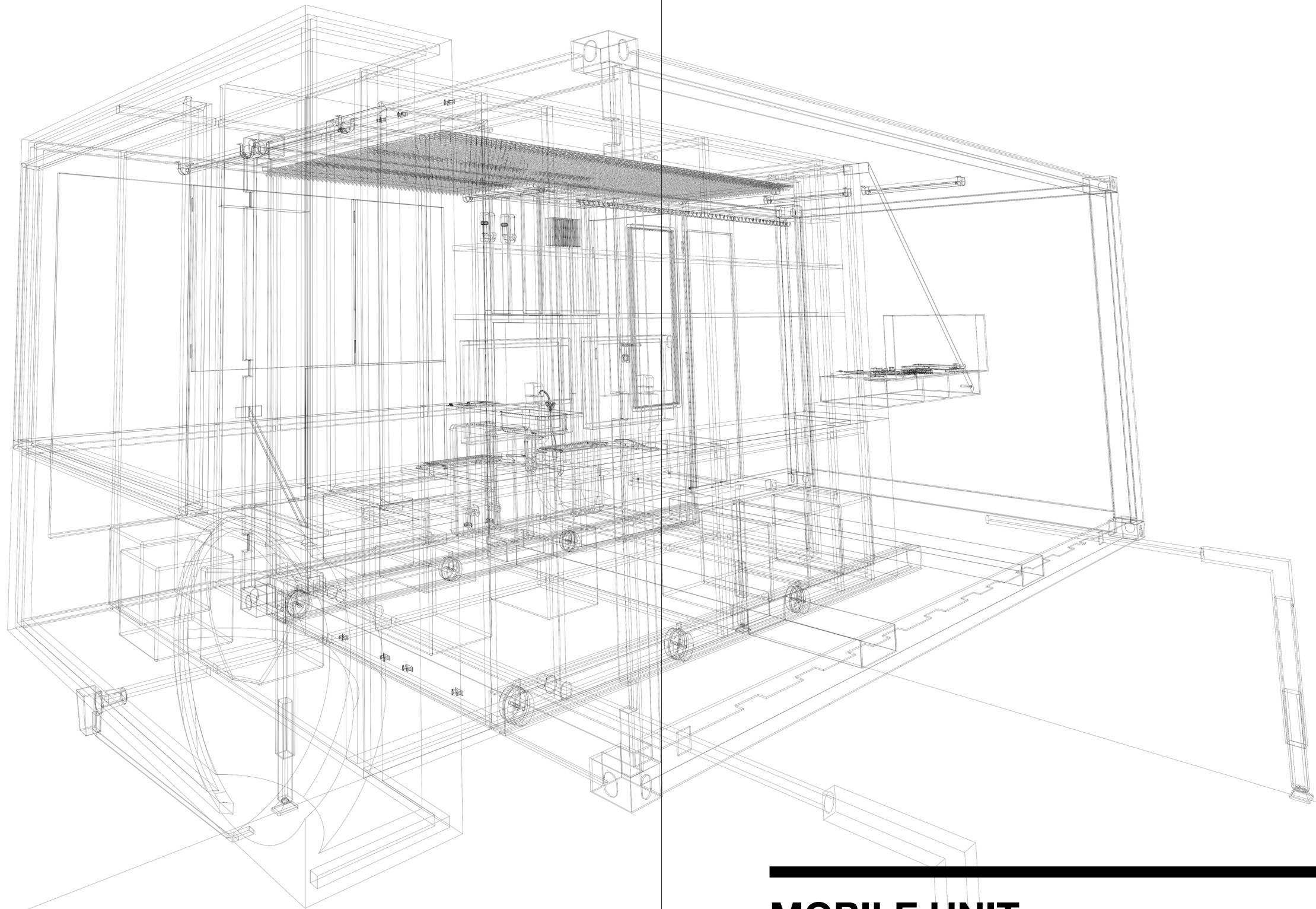

**MOBILE UNIT:
SPACE MODULE**

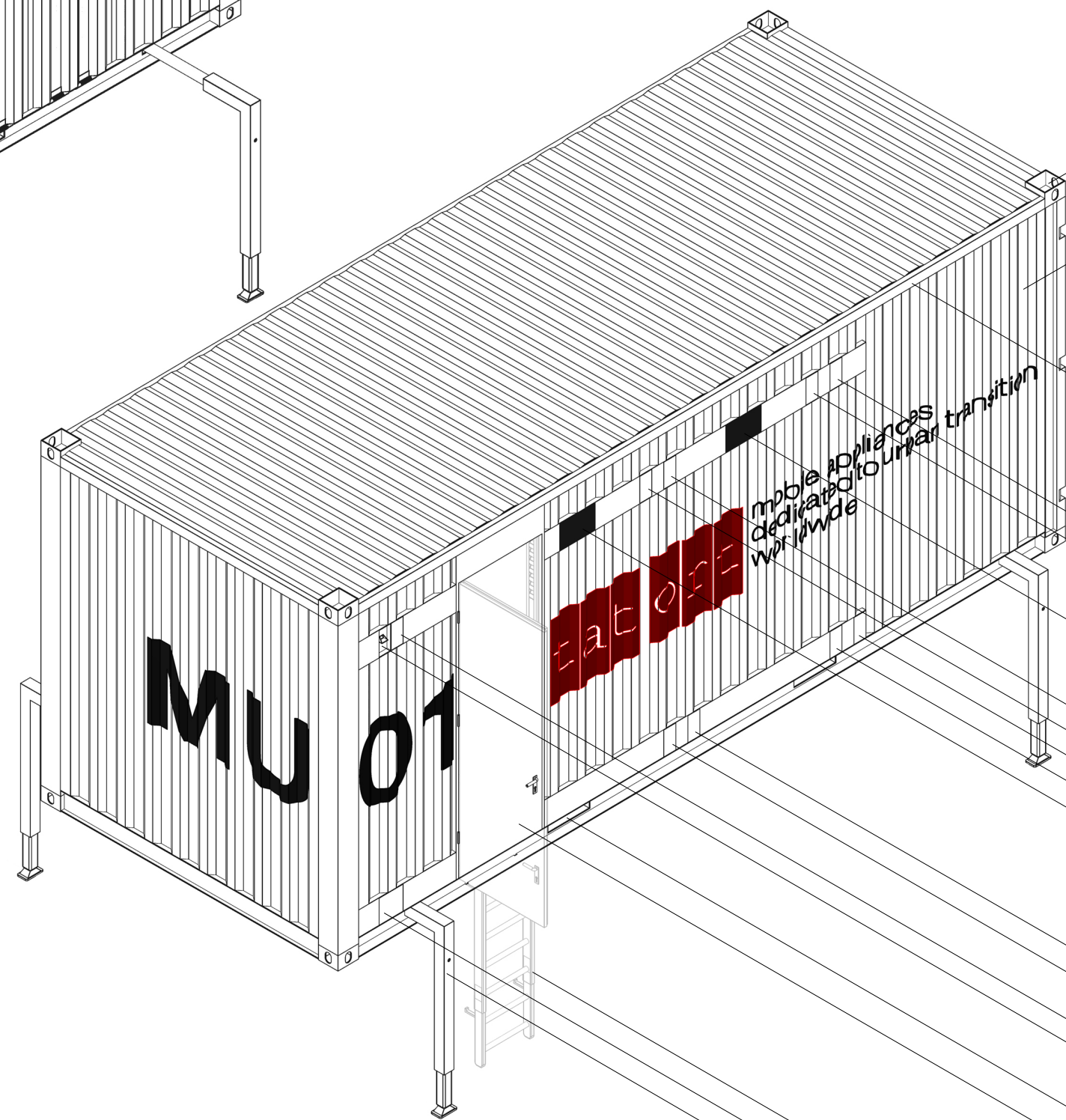
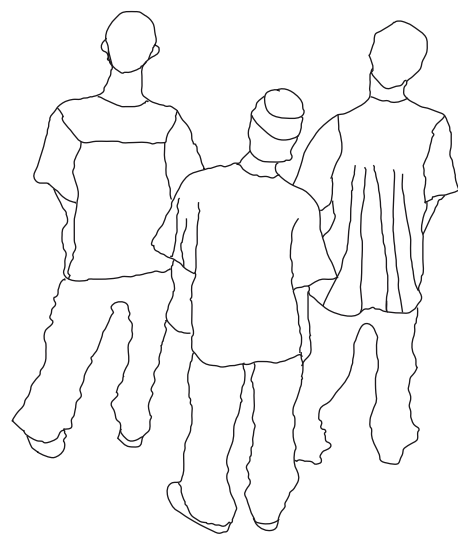

- Corner fitting/air lift
- Side panel, openable
- Container-chassis
- Drinkable water refill for space module deployed
- Toilet water refill for space module deployed
- Ventilation grill for space module deployed
- Drinkable water refill for space module in transportation lock
- Toilet water refill for space module in transportation lock
- Wastewater discharge for space module deployed
- Toilet wastewater discharge for space module deployed
- Ventilation grill for space module in transportation lock
- Wastewater discharge for space module in transportation lock
- Toilet wastewater discharge for space module in transportation lock
- Gas refill
- Exhaust of gas generator
- Forklift pocket
- Door to the container
- Ladder for container entrance
- Sockets for external power supply
- Landing gear

**MOBILE UNIT:
CONTAINER SHELL**

Container chassis

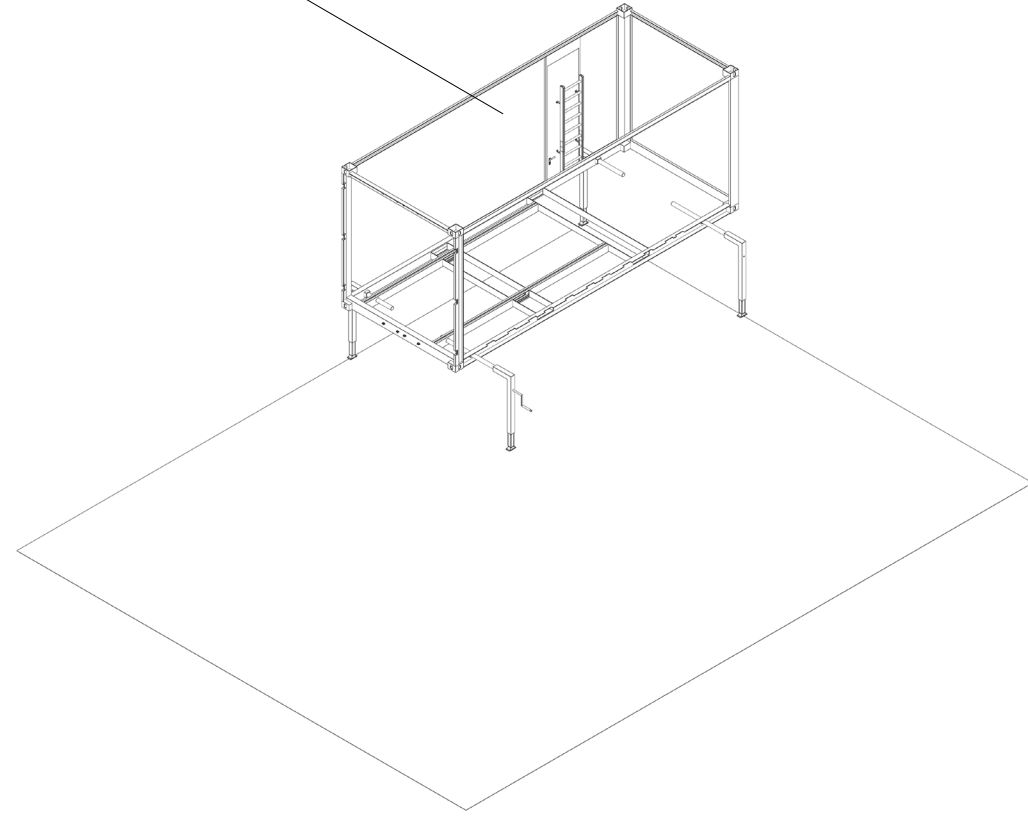

Space module, furniture, appliances, and computer interface

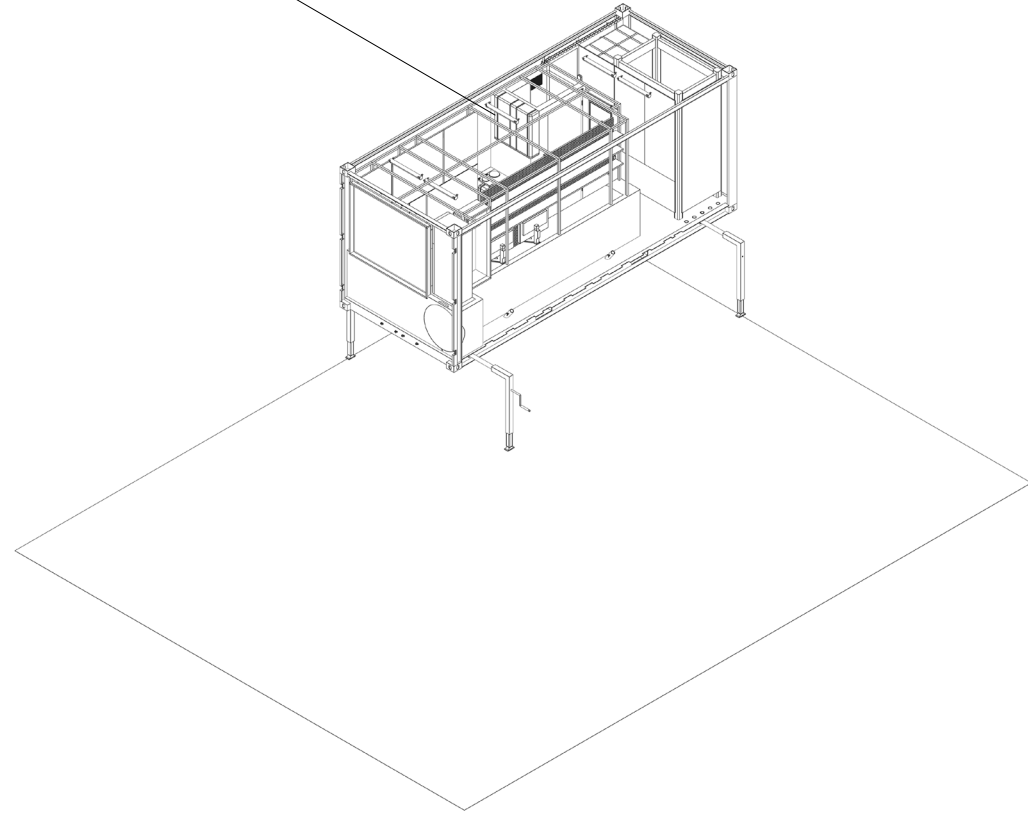

Container shell

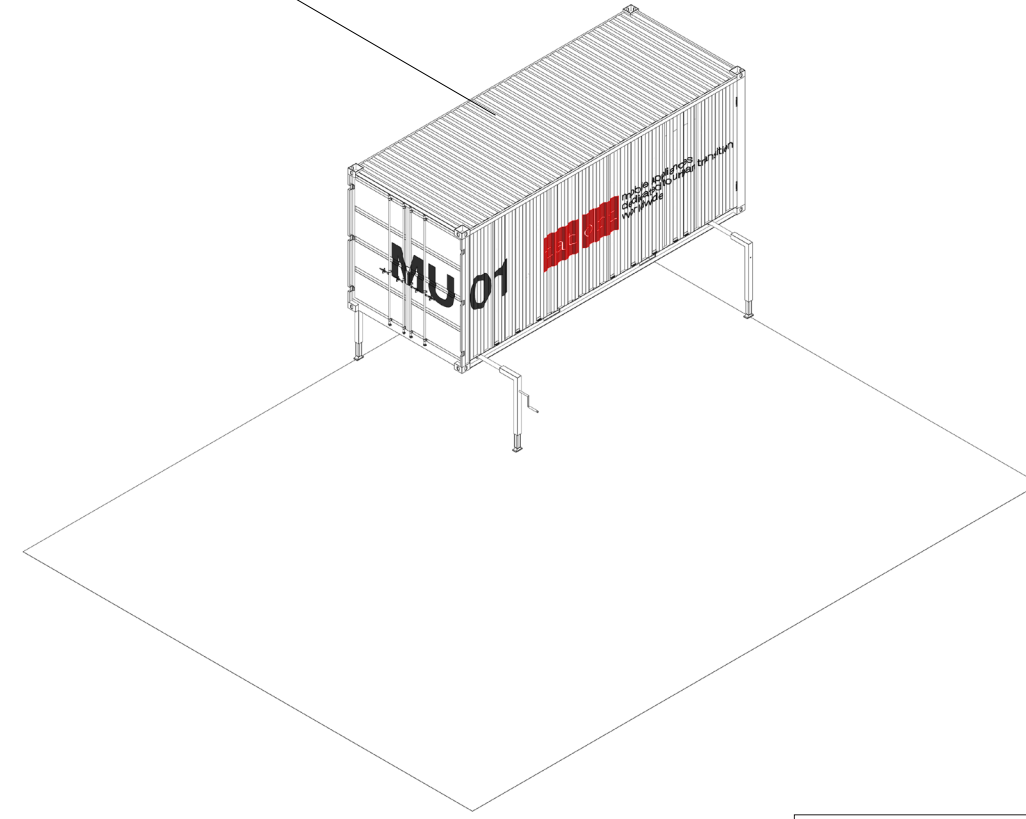

Sitting stairs and flightcase unfolded

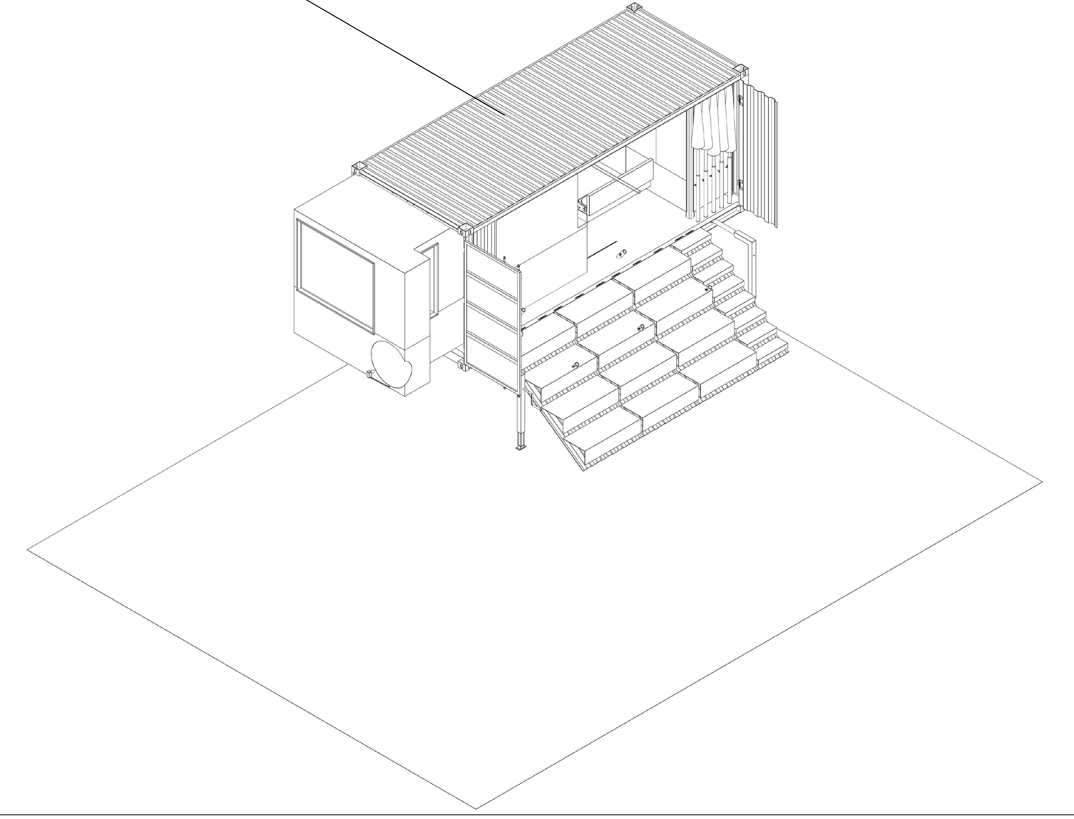

Electrical infrastructure and milling machine

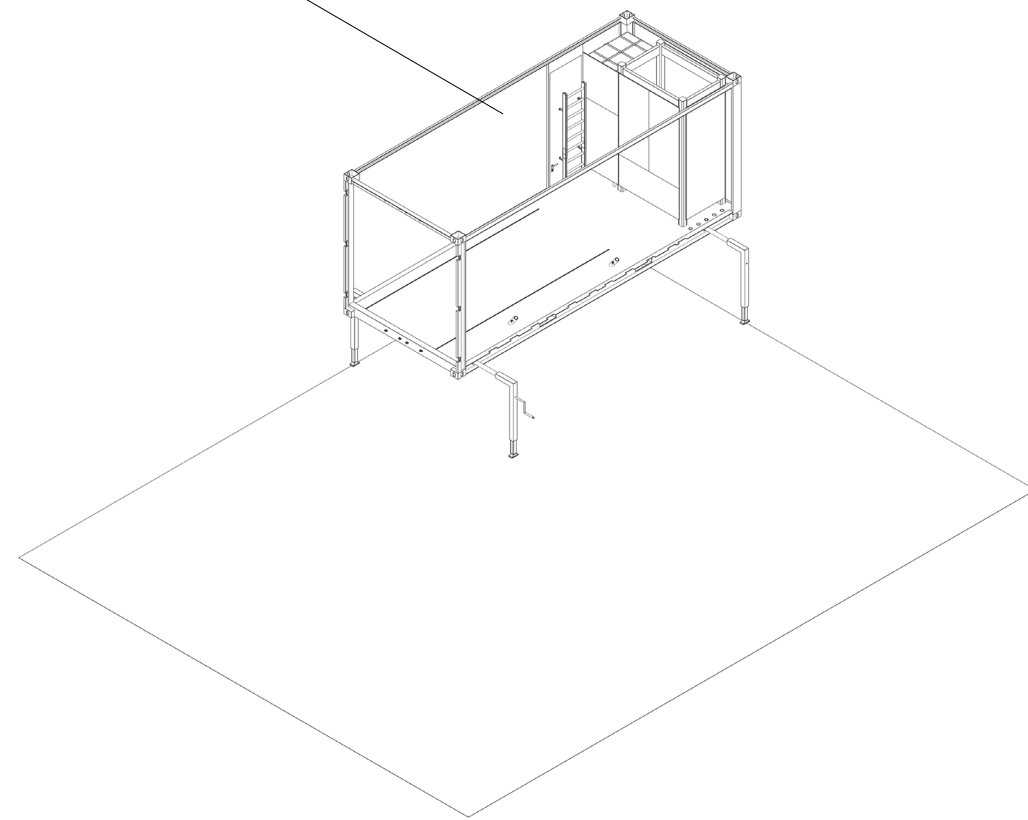

Container fully equipped, space module locked

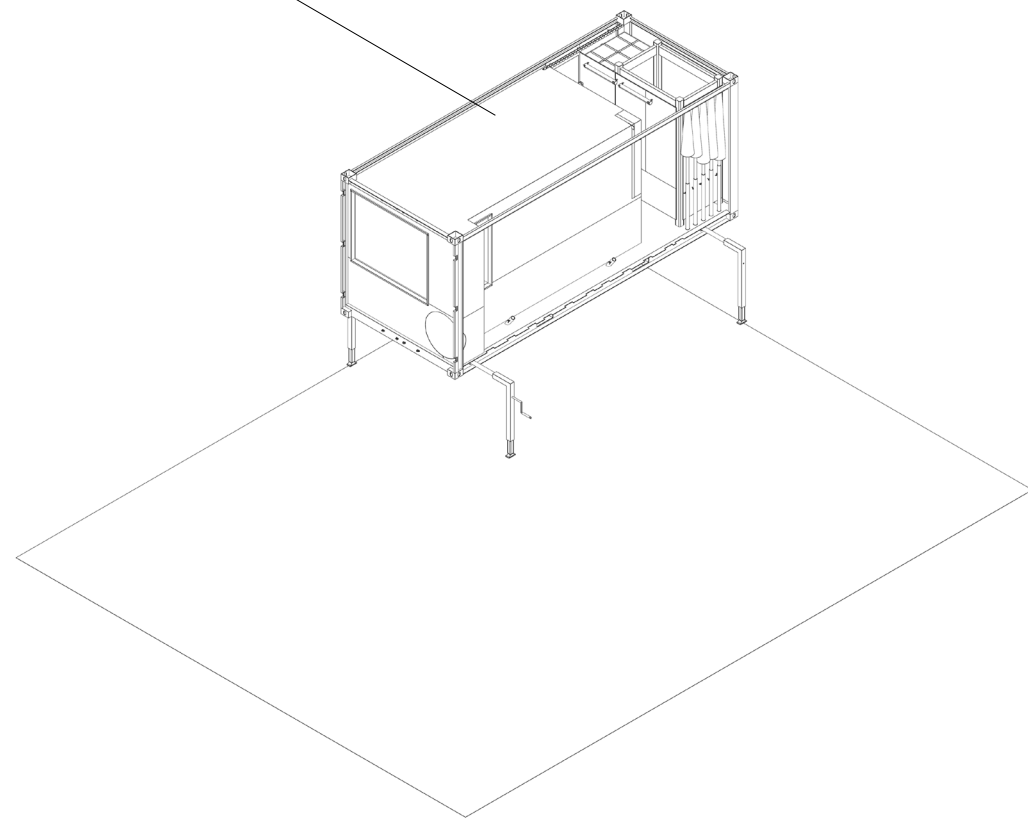

Front doors open and staircase unfolded

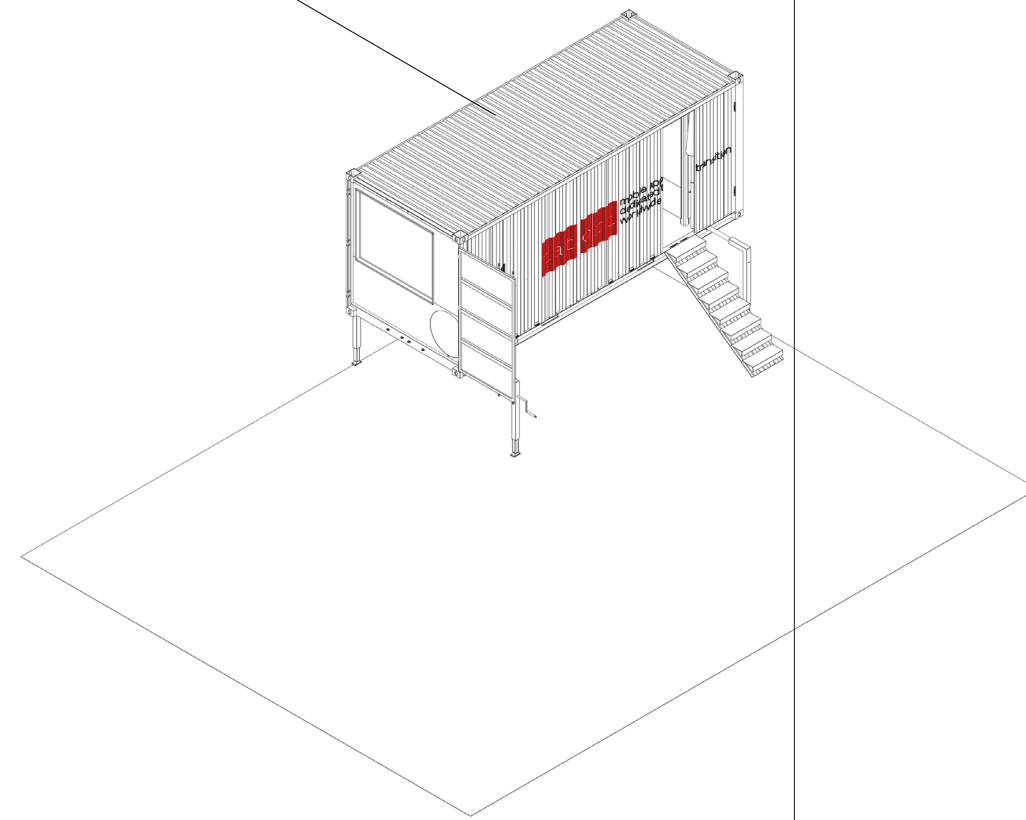

Mobile unit fully operational

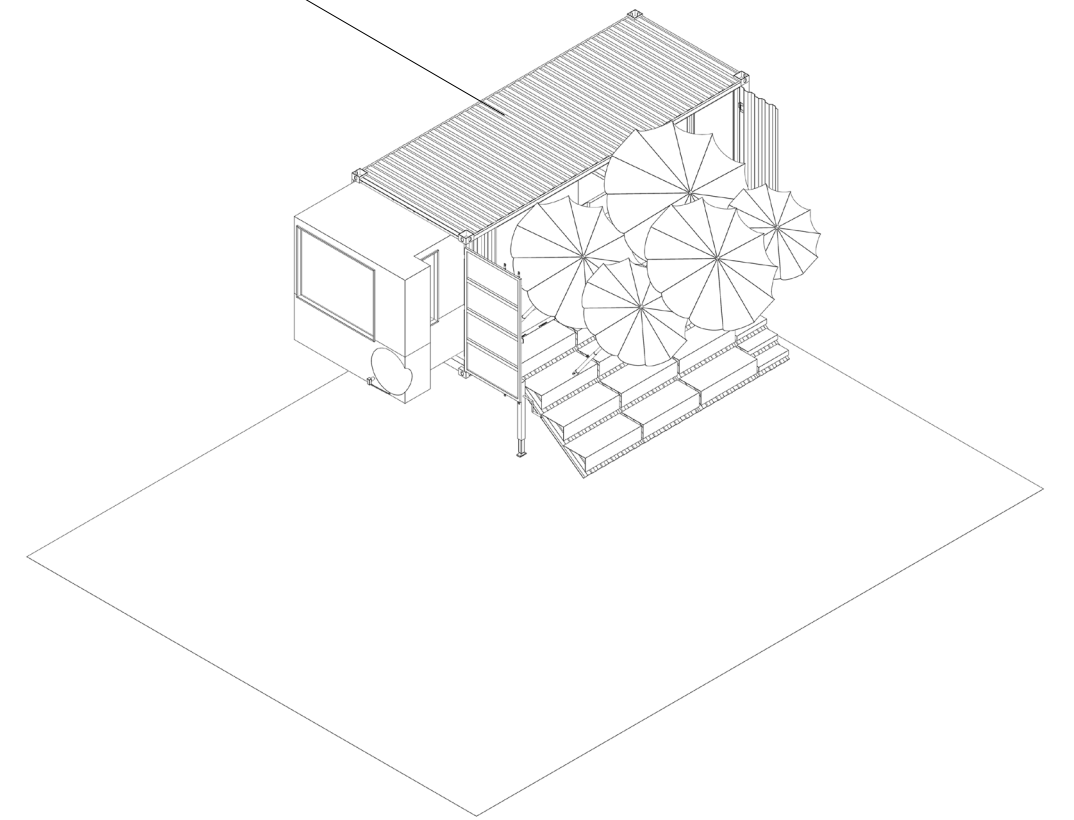

Space module, structural components

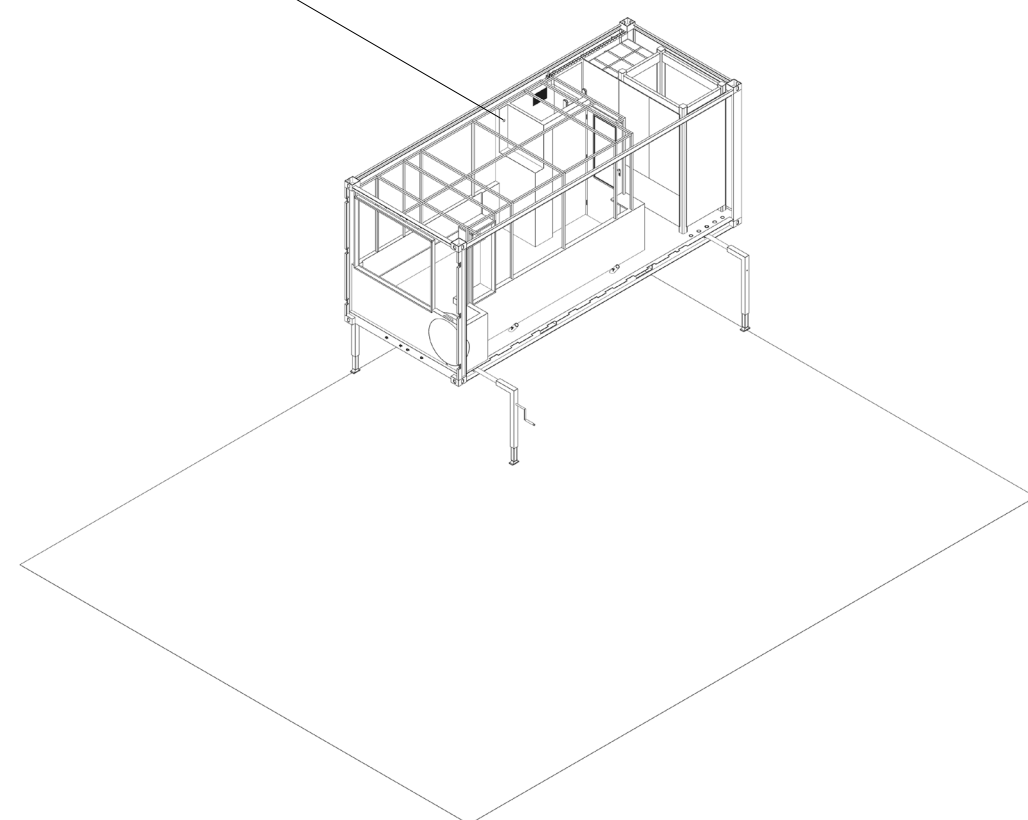

Container side panels

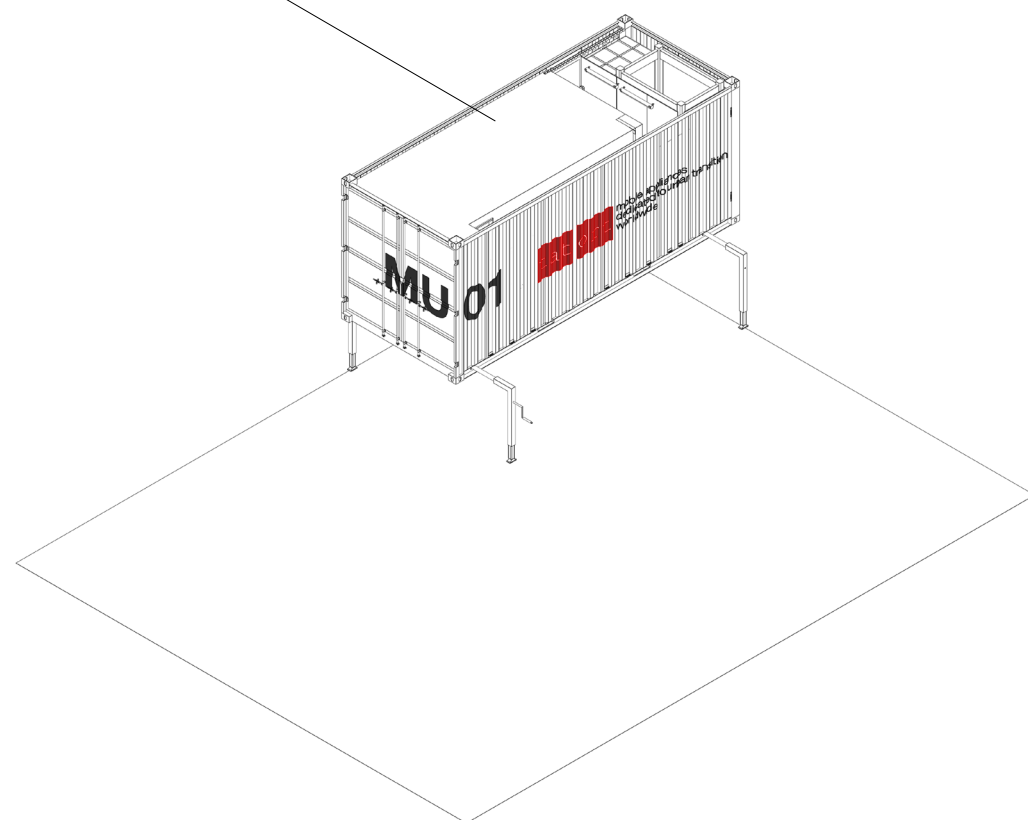

Space module deployed

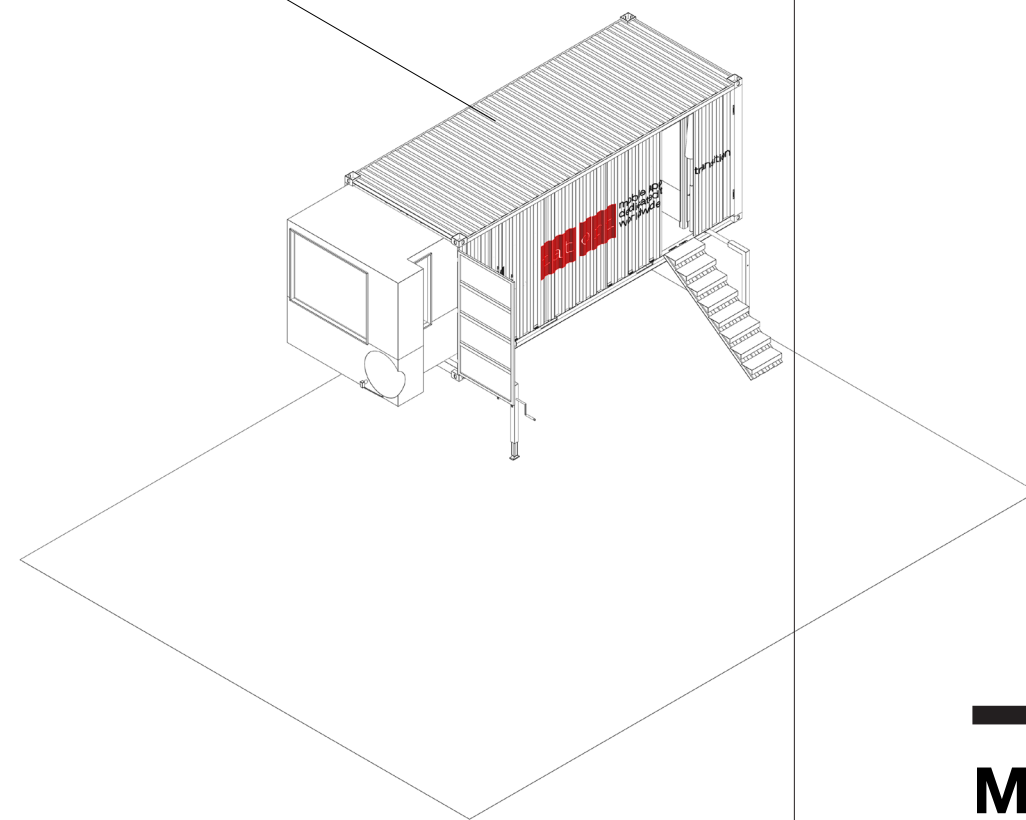

**MOBILE UNIT:
UNFOLDING STAGES**

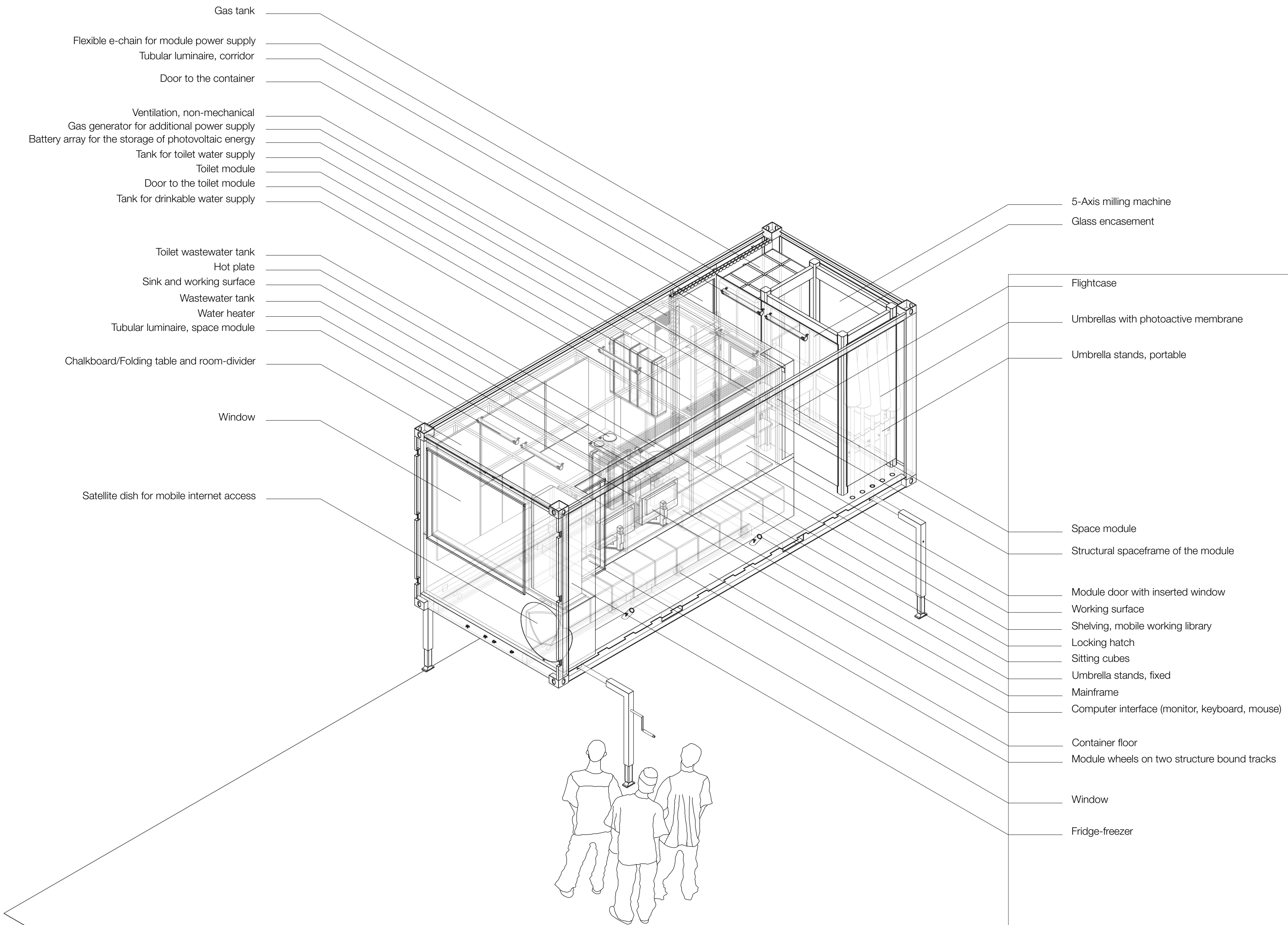

**MOBILE UNIT:
SPACE MODULE IN PARKING LOCK**

Flexible e-chain for module power supply, stretched
Door to the container
Ladder to enter the container

Locking hatch, acoustically effective
Structural spaceframe of the module
Space module
Window
Chalkboard/Folding tables
Sitting cubes
Satellite dish
Feedhorn, mounted

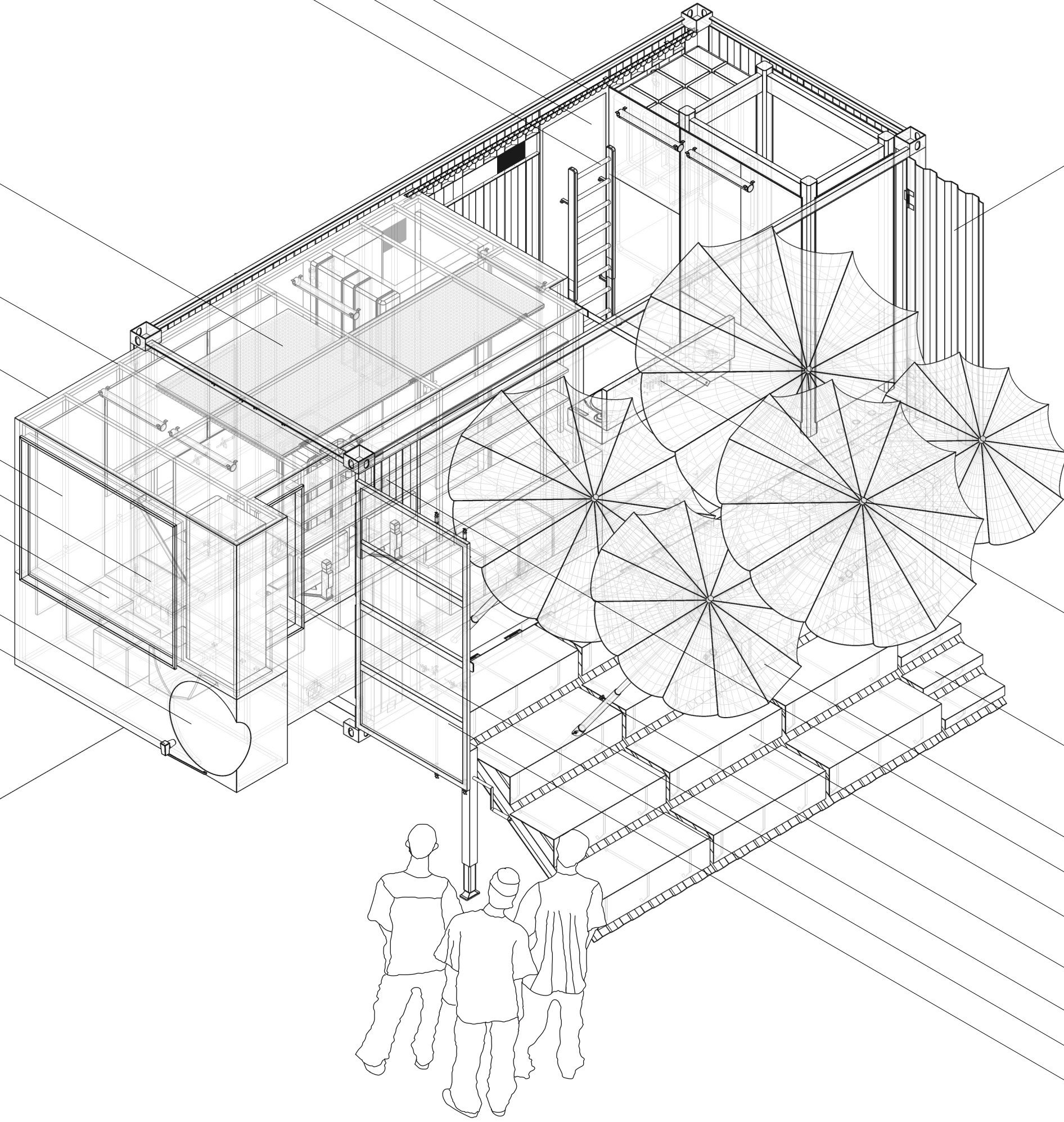

Container sidepanel, openable
Flightcase, unfolded (2 decks, mixer, amplifier, speaker)
Staircase, unfolded
Umbrellas with photoactive membrane
Container sidepanel, fixed
Seating steps, unfolded
Umbrella stands, portable
Umbrella stands, fixed
Window
Container door wing

**MOBILE UNIT:
SPACE MODULE DEPLOYED**

Space module in parking lock

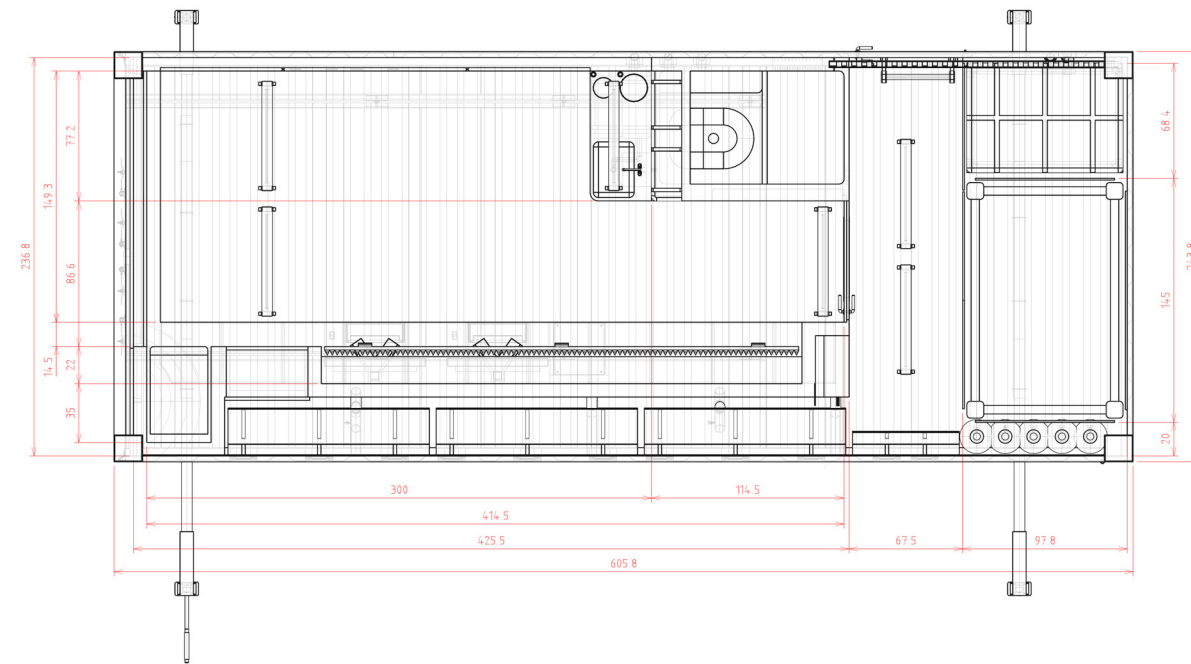

Mobile Unit fully operational

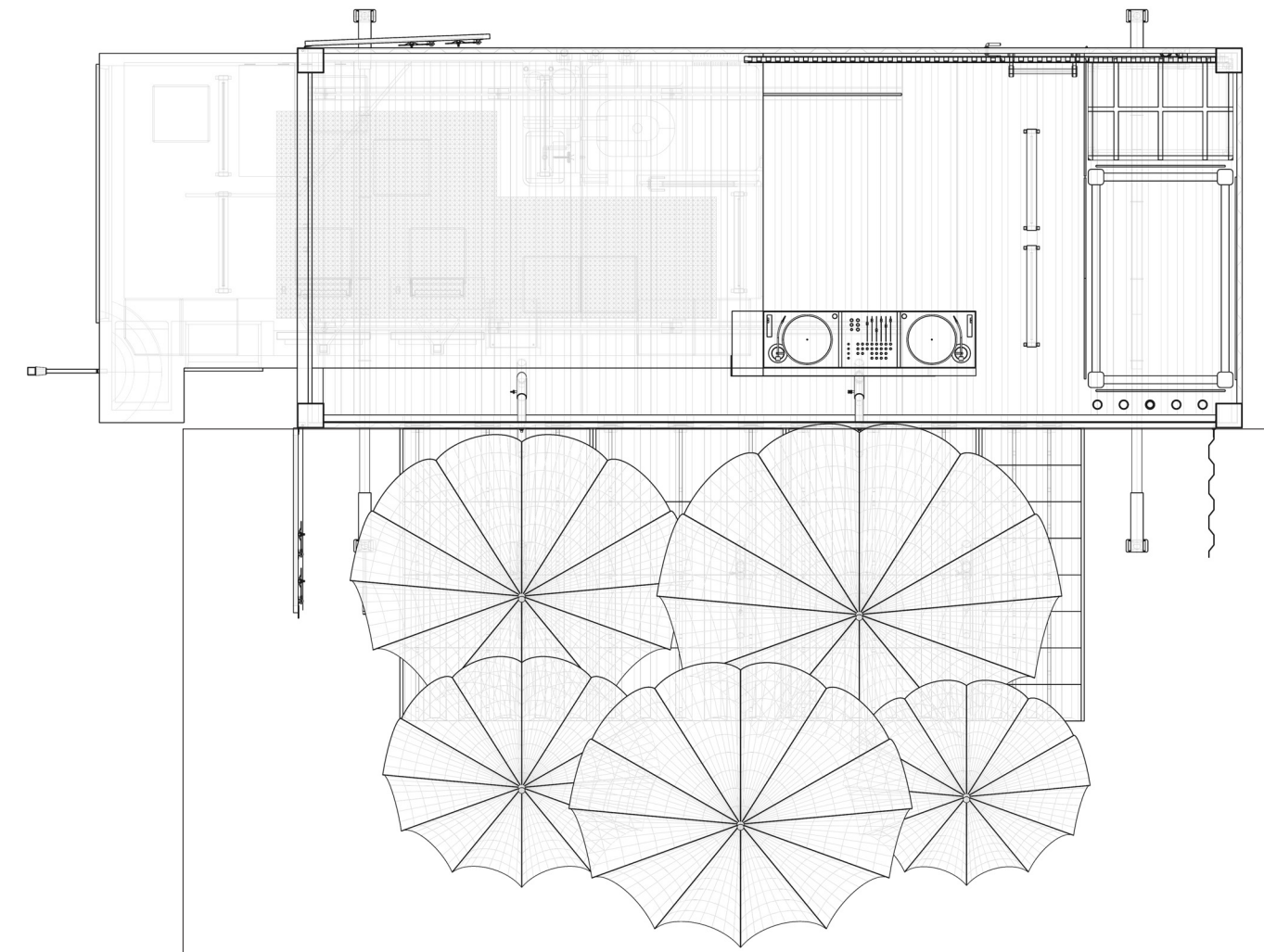

Space module deployed, sitting stairs unfolded

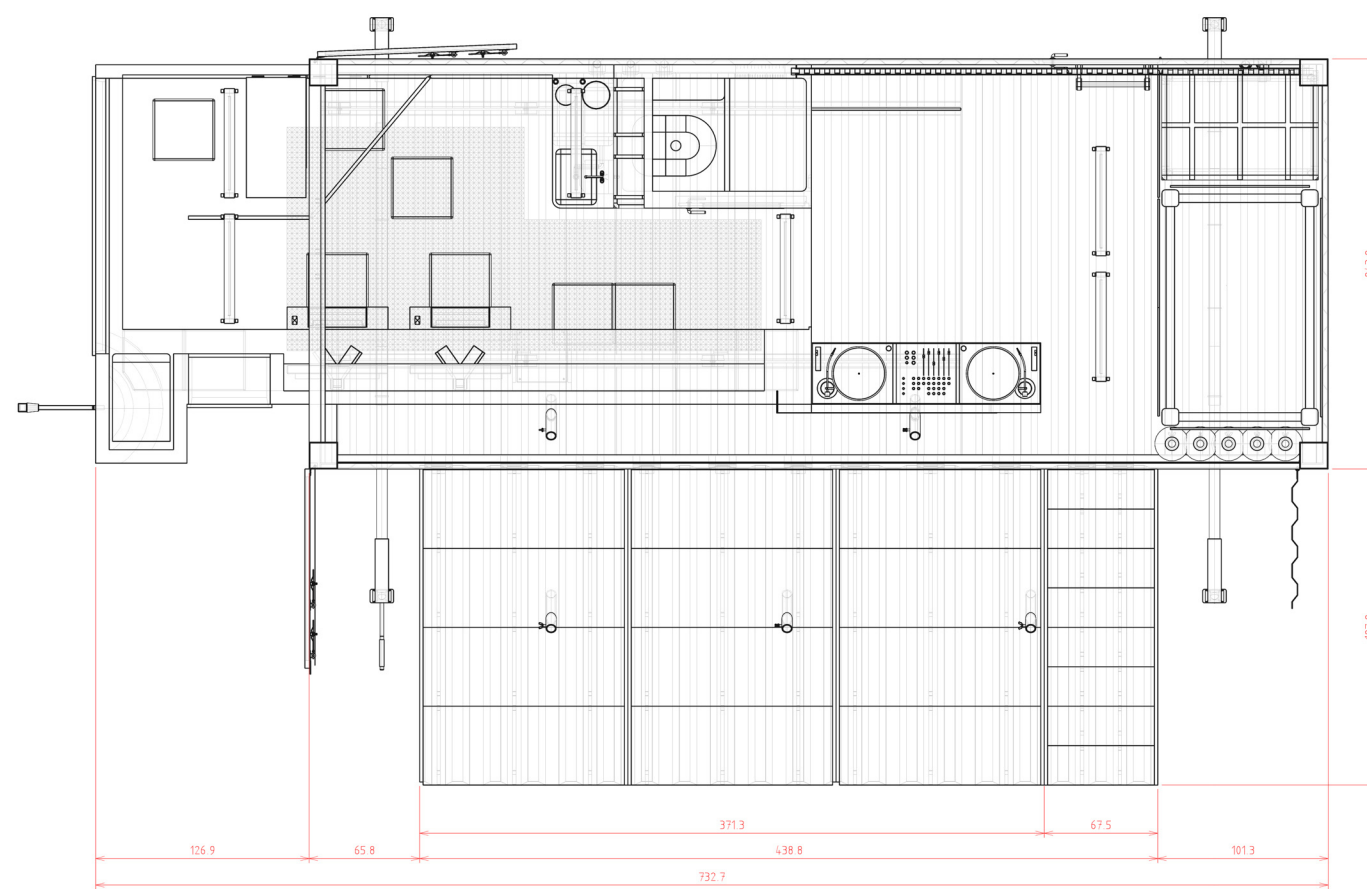

Mobile Unit, front elevation

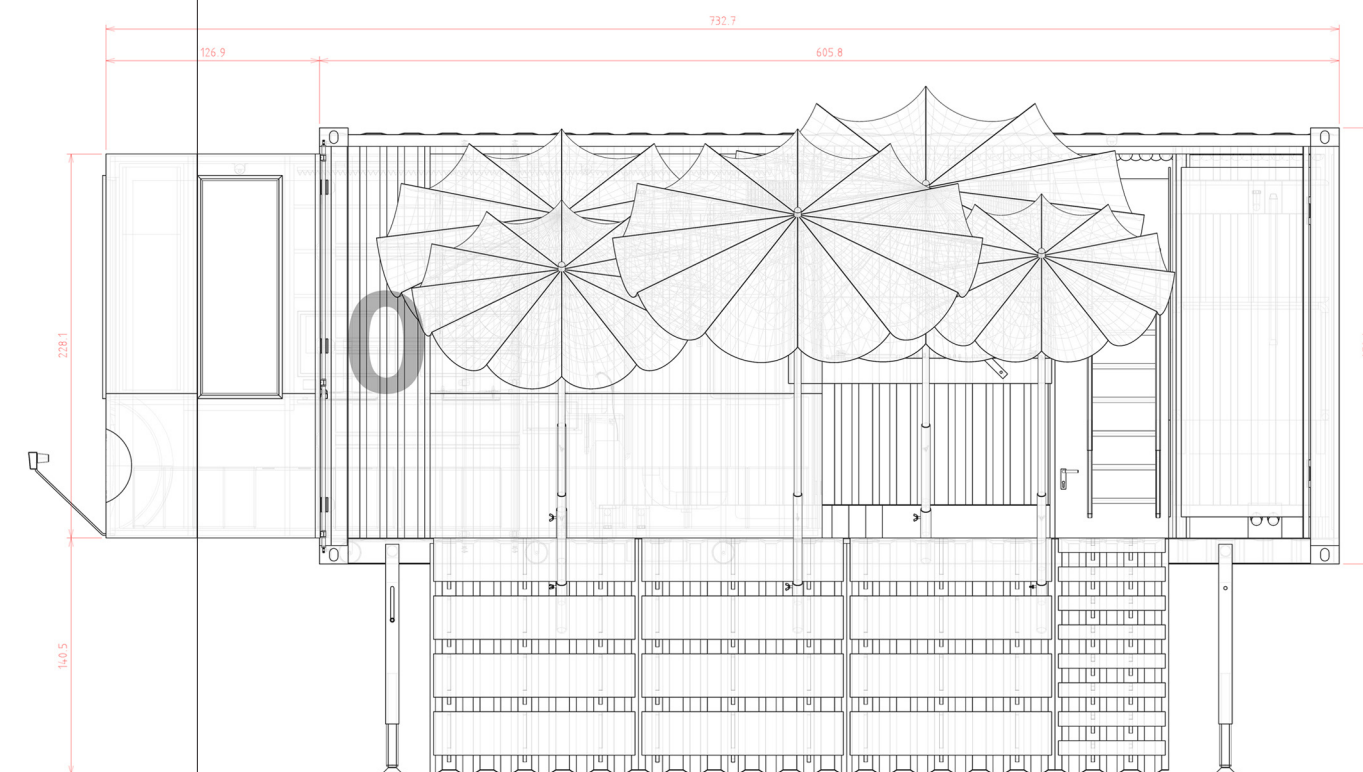

MOBILE UNIT: FLOOR PLANS AND ELEVATION

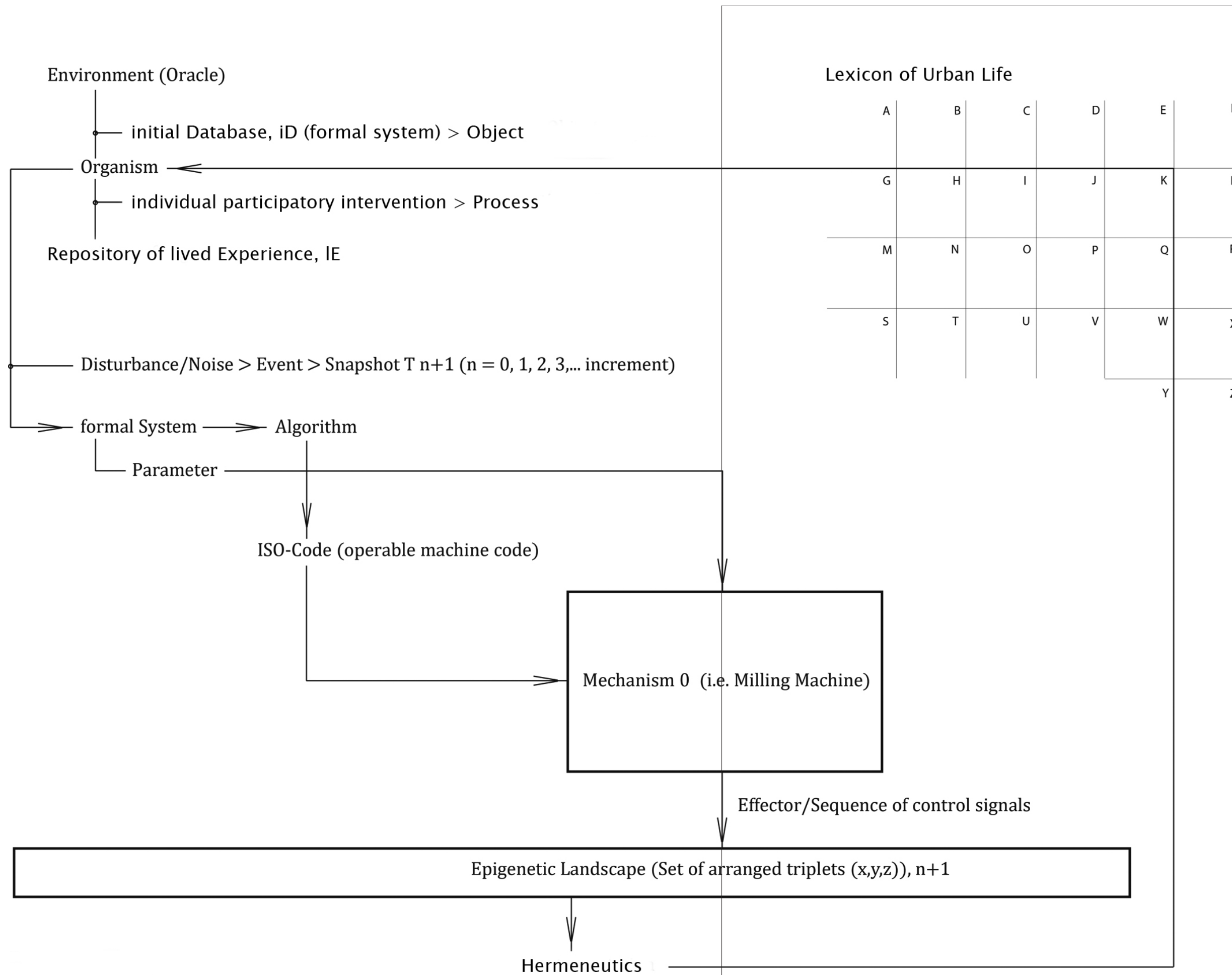

**MOBILE UNIT:
SYSTEM ARCHITECTURE: FLOW CHART**

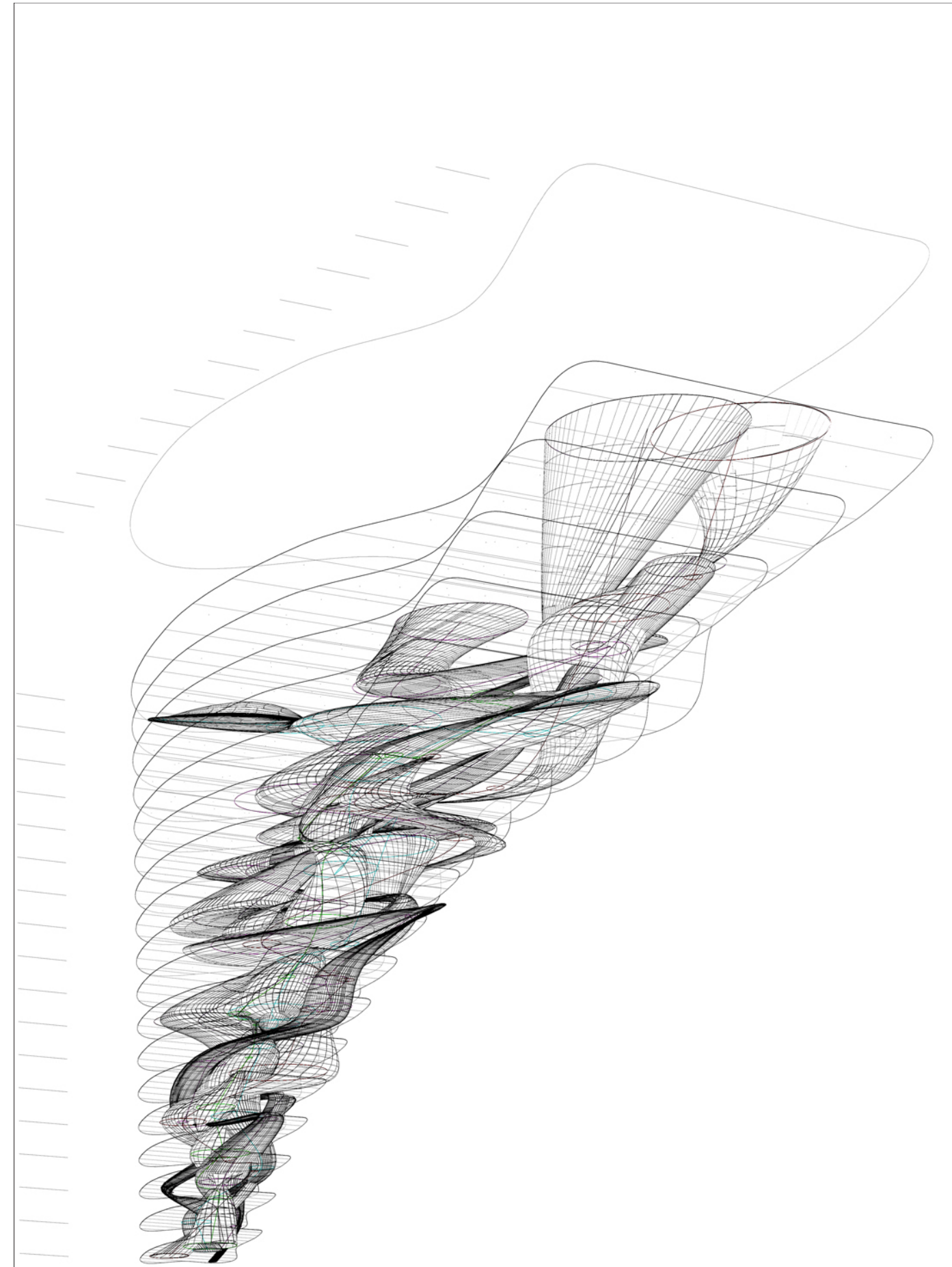
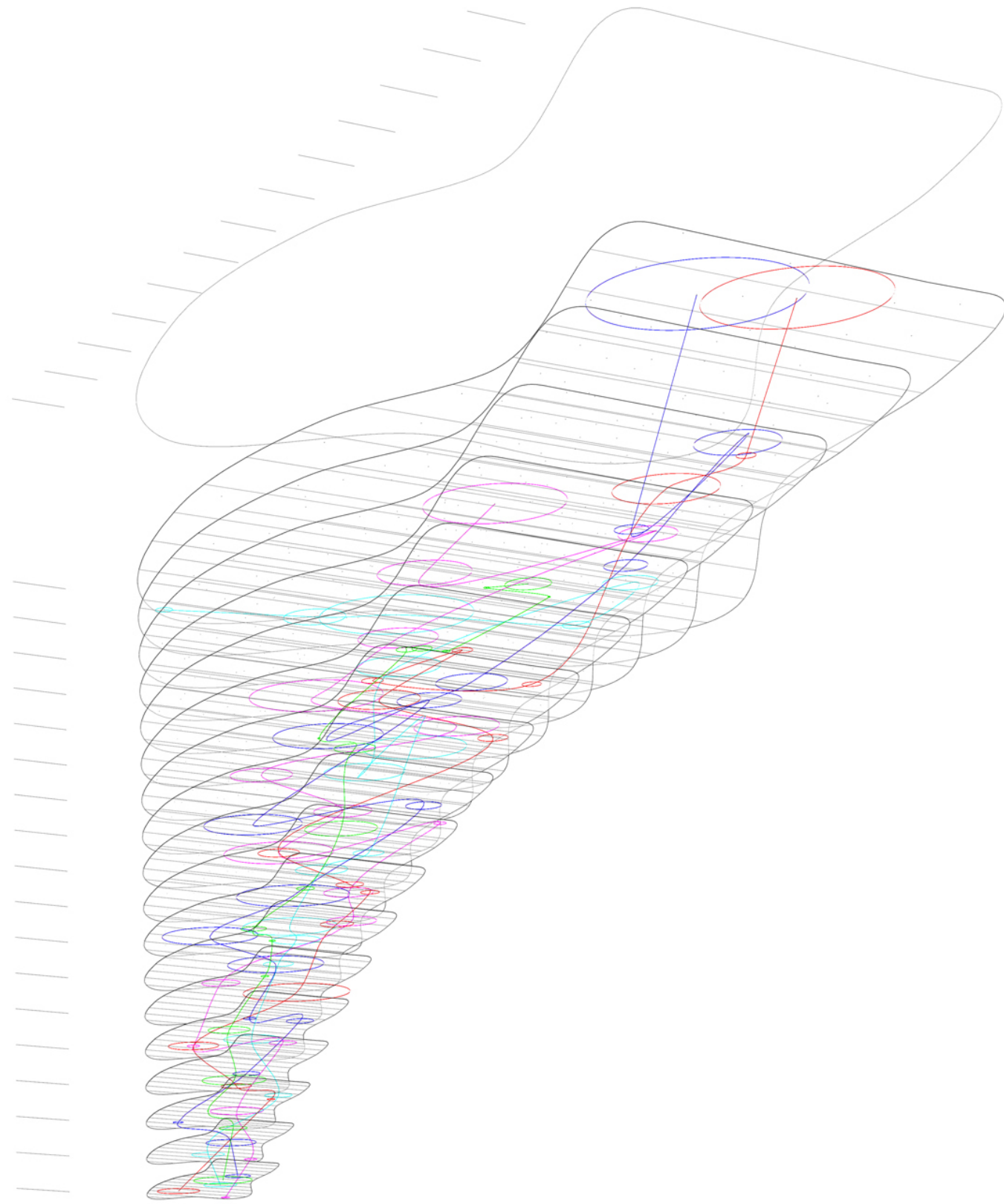

**MOBILE UNIT:
DATABASE**