

Validating the Student Loyalty Model for an Open Distance Learning Institution

Norlia Goolamally

Open University Malaysia ◆ Malaysia ◆ nolee@oum.edu.my

Latifah Abdol Latif

Open University Malaysia ◆ Malaysia ◆ latifah@oum.edu.my

ABSTRACT

University students' loyalty is a key factor that contributes to the long term growth and survival of a university. The aim of this research is to develop a comprehensive university student loyalty model that incorporates important constructs in service quality dimension and relationship quality dimension. The study sample comprised of 2068 respondents who are undergraduate students from an open distance learning institution. Exploratory factor analysis through principal component technique with varimax rotation of the 48 items questionnaire from four constructs was able to account for 79.27% for the variance in student loyalty. The proposed model was empirically tested to validate the framework. Structural Equation Modeling was employed to test the significance of relationship between the constructs in the instrument. Results confirmed that all path coefficients reflecting the relationship between constructs are statistically significant. Students' loyalty is significantly influenced by trust, emotional commitment and satisfaction. Path analysis suggests that service quality impacts loyalty through satisfaction, trust and emotional commitment. In this study, it is seen clearly that customers' satisfaction plays the role of mediator in the effects of service quality on student loyalty. The path analysis also confirmed that trust and emotional commitment have direct effects on loyalty. Hence, acquiring students' satisfaction through quality services, building trust and emotional commitment are import aspects in securing students' loyalty.

INTRODUCTION

The concept of relationship marketing is applicable in higher educational institutions as they are generally recognized as business organizations focus on providing services to students as their customers. One of the strategic goals sought after by any higher education institution is to be able to attract and retain students and efficient relationship marketing practices promises higher student retention (Sheth and Parvatiyar 1995).

It is crucial to understand students' desires and need as well as their inner reasons to keep or end a relationship with the university. Once a relationship is bonded between students and the university, the likelihood of students dropping out of the system will be reduced and there will exist strong commitment from the students.

The objectives of this study are twofold; first, to examine the relationship between key antecedents that influence students' loyalty to the institution. The constructs to be examined are service quality, satisfaction, trust, emotional commitment and loyalty. Second, to develop a Student Loyalty Model based on the identified constructs. The conceptual framework for the Student Loyalty Model was introduced based on literature research.

Literature Review and Conceptual Framework

Governments have realized the importance of developing the intellectual capital of their citizens as knowledge is the key resource in the globalized era. Therefore the topic of lifelong learning has become of huge importance in the policies and practices of many higher educational institutions. Universities have to work harder to attract and identify their desired and potential students. They have to develop appropriate and current programmes and create a positive learning experience throughout the undergraduate and graduate levels. In order to create loyal lifelong learners, the university requires thoughtful strategies with relevant content and building the most flexible learning environment. This is one of the strategies to create an ecosystem where the centre of which is the lifelong learner (Pausits and Pellert 2007). The lifelong learners yearn for education, equipped with the latest mobile devices; smartphones and tablets and extensively used the social media for communication. The lifelong learners have high expectations from their institutions and this makes the degree of satisfaction more challenging to achieve. Thus, higher education institutions have to compete with each other in order to survive. Thoughtful and careful strategies can transform the students to become loyal students and thus create sustainable ecosystem (Pausits and Pellert 2007).

Research on student loyalty is seen to be heavily based on Tinto's model of student drop-out behavior, in which was inspired by the early works of Spady in 1970. Highly concentrated in commitment and integration, Tinto's theoretical model describes the communication process between students and higher institutions as well as looking into each student's background in terms of family, expertise and education (Tinto, 1993).

Tinto's model takes on the assurance and assimilation constructs that are correlated within a process that is active where Tinto himself describes a student's commitment is the best concept that encourages loyalty (1975, 1993). On the other hand, the correlation between assimilation and loyalty is moderated by the student's promise. A student's commitment could also be increased due to the student's ability to assimilate his or herself through the academic and social system of a higher institution. According to Tinto, the act of commitment are split into three parts; the student's promise towards his or her goals (goal commitment), the student's promised towards his or her university (institutional commitment) and finally an outward promise that showcases the student's activities outside the compound of the university as well as his or hers interests which, in Tinto's opinion, could deter a student's loyalty towards his or her university (1975, 1993).

Many researchers consider Tinto's model as the best groundwork for future research that tries to describe the loyalty policies that are utilized by some higher institutions in the United States. Nevertheless, authors such as Bean and Metzner (1985), Grubb (1989) and Tierney (1992) assumes that there are weaknesses within Tinto's research framework. Based on Seidman's study of the United States' universities' graduation rates, he concluded that curriculum and facilities within the scope of loyalty that were based on Tinto's framework did not have any changes towards a student's devotion towards the university. The problem that lies within the framework is that it only looked into the student's commitment in other aspects that are only reflected in a secondary manner. On the other hand, Tinto also incorporated the value of teaching as the factor within the assimilation issue rather than being the actual precursor of the question of a student's loyalty.

Theoretical View of Constructs

An increasing body of research supports the idea that customers' satisfaction with goods and services leads to their brand loyalty (Suh and Yi 2006; Xu et al. 2006). Satisfaction is an important variable to comprehend the loyalty term, which could be clearly seen after a customer buys a product where the customer would appraise the company's performance without the knowledge of the employee that sold the product (Crosby, Evans and Cowles, 1990; Palmer and Bejou, 1994; Hennig-Thurau and Klee, 1997; Garbarino and Johnson, 1999). According to Hennig-Thurau and Klee (1997), satisfaction is a powerful loyalty antecedent that could affect any other concepts.

Service quality is one of the antecedents of customer loyalty besides satisfaction. The quality of service provided to students is quite subjective dependent on the interpersonal skills of staff and the conduct of students (Kotler 1982). The aspects of service quality measured are effectiveness of course delivery, mechanisms and the quality of courses and teaching (Athiyaman 1997; Bournier 2011). In this study, service quality is constructed to be a set of services provided by a higher education institution that encompasses the effectiveness of the teaching and learning process, the learning materials and the learning facilities provided at the various learning centres.

According to Mouzas (2007), another key element within the customer loyalty and relationship is trust, which is connected to excellence. Doney and Canon (1997) also described trust as reliability and attentiveness that are observed by the customer towards an organization; or better known as "goodness" within the entire organization or a specific employee (Crosby, Evans and Cowles, 1990; Wong and Sohal, 2002). Millar and Rogers (2007) proposed that trust is an essential foundation within a relationship marketing area that could somehow create a worthy bond where a person could find an expected and compulsory behavior that is shared with his or her relational companion; this relationship is closely related to any compensations in the coming months or years.

Enhancing students' emotional commitment to the institution is of top priority to any educational institution. Emotional commitment to an affiliation is best described as the foundation of a worthy relationship. According to Garbarino and Johnson (1999); Pritchard, Havits and Howard (1999) and Fullerton (2003), emotional commitment is considered to play an important factor within the loyalty concept. In addition, loyalty will be formed when emotional commitment has an arbitrating effect or in other words, loyalty could only be achieved with an emotional commitment from a customer (Pritchard, Havitz and Howard, 1999, p.345). Du Plessis (2010) claimed that emotional commitment is the

outcome of good relational interactions and is affected by customer's perception of the effort made by the seller.

Student Loyalty in the Context of a University

According to Milliken (2007), the student-client's decreasing loyalty towards education is proving to decrease the chances for many universities to survive. This scenario is not really a new realization for all universities; however within the last 10 years of the 20th century, this problem is given more consideration especially in areas which touch upon the issues of globalization and the constant struggle between all higher institutions (Milliken, 2007). The study by Schwartzman (2003) clearly describes how the epidemic of dropping out among students has become a concern especially in the question of a university's existence. Apart from that, concerns such as criminal behavior, unoccupied vacancies and a decreasing number of lower-class students are also considered to be issues that are rising amongst universities.

Oliver (2007) stated that the practice of loyalty is a purchaser's commitment in building a connection and is dedicated to purchase the product or service more than once. Due to this factor, loyalty can be seen to have a behavioral factor that identifies with the idea of a goal to repurchase including an attitudinal factor that is constructed on the basis of predilections and the impression of someone close to them (Sheth and Mittal, 2003).

Berger and Lyon (2005, p.3) described retention within universities as the aptitude for a learning institution to effectively graduate students that are currently studying within the institution. Kotler and Fox (1994, p.383) indicated that it is very important to keep the enrolled students, which is as vital in attracting and recruiting the students. These studies indicate that universities should reconsider its relationship with the students as valuable especially in the areas of student retention, which also includes a transformation of the university's structural beliefs. Nevertheless, Herzog (2005, p.923) believes that the method of student retention is not an easy task theoretically and institutionally.

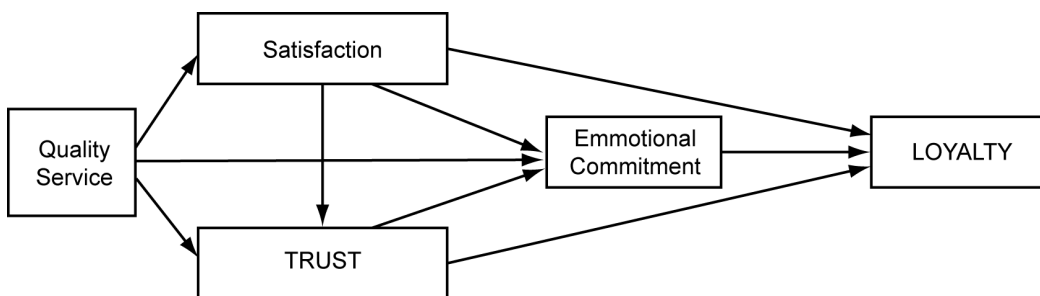

Figure 1: Student loyalty model

The model in Figure 1, shows that student loyalty is determined directly by four constructs, satisfaction, quality service, emotional commitment and trust. Quality service is made up of several elements which include the facilities at the learning environment, administrative services, and competencies of the tutors, the modules and the e-learning platform. Based on the study conducted by Boulding et al. (1993), service quality is necessary for customer loyalty in an educational context. The students' trust in the educational institution is understood as the students' confidence in the university's integrity and reliability (Morgan and Hunt 1994). It is based on the personal experiences each student

has had with faculty members. Trust is also perceived to be a direct antecedent of student loyalty. Students' emotional commitment to the educational institution is another construct included as a determinant of student loyalty in the Student Loyalty Model. Students' emotional commitment to the university plays a central role in traditional educational research on student loyalty.

Research Objectives and Research Hypothesis

The objective of this research is to examine the relationship of the constructs incorporated in the study. Loyalty Model that offers a comprehensive view of relationships between constructs in a service quality dimension, satisfaction, trust, emotional commitment and loyalty at an Open Distance Learning Institution.

Accordingly, the following are the hypotheses statement for this study:

H1: Service Quality has a significant positive effect on students' satisfaction

H2: Service Quality has a significant positive effect on trust

H3: Satisfaction has a significant positive effect on trust

H4: Satisfaction has a significant positive effect on emotional commitment

H5: Satisfaction has a significant positive effect on loyalty

H6: Emotional commitment has a significant positive effect on loyalty

H7: Trust has a significant positive effect on loyalty

Research Methodology

The study used a quantitative research design where the main instrument is a survey questionnaire. The 62-item questionnaires were disseminated using the online survey tool Survey Monkey (www.surveymonkey.com). A link to the questionnaire was sent to all students via their learning management system, myVLE. The original instrument has 62 items and consists of Parts A, B, C, D, E.

Data Analysis Procedure

Exploratory Factor Analysis (EFA), through principal component technique using varimax rotation was applied to analyse the data. Items with communalities less than 0.500 were deleted. EFA was applied to the data set to determine the underlying factors under the respective constructs. Factor analysis was performed to obtain a more-parsimonious measure of Student Loyalty. Initial criteria to retain the factors are factors with Eigen values greater than one and items with factor loadings less than 0.30 were suppressed. The EFA analysis of the pilot study enabled the researchers to redefine the items and to remove some unfit items.

This research employs the two-step structural equation modeling approach, which separates the analysis into two steps, the Confirmatory Factor Analysis (CFA) (the measurement model) and the path analysis (structural model). The two step approach is preferred because it warrants good measures before conducting the path analysis. Firstly the full measurement model with 2068 had been developed removing items with low factor loading (while maintaining theoretical congruence). It is important to ensure that the number of items per construct is at least three to keep the model "overidentified" which is essential to conduct the structural equation modeling analysis.

Data Analysis

An exploratory factor analysis of the 62 items of the Student Loyalty Questionnaire was performed on the data from 2068 students. Prior to running the analysis with IBM SPSS, the data were screened by examining descriptive statistics on each item, inter-item correlations and possible univariate and multivariate assumptions violations. From this initial assessment, all variables were found to be interval-like, variable pairs appeared to be bivariate normally distributed and all cases were independent of one another. The variables-to-cases ration was deemed adequate due to the large sample size. The Kaiser-Meyer-Olkin measure for sampling adequacy was 0.976, indicating that the present data were suitable for principal component analysis. Similarly Bartlett's test of sphericity was significant ($p < 0.001$), indicating sufficient correlation between the variables to proceed with analysis. A total of eight factors had eigenvalues greater than 1, cumulatively accounting for 79.27% of the total variance.

Consequently 14 items were deleted from the original questionnaire of 62 items. The final instrument consists of 48 items; 32 items dealing with Service Quality, comprising four different constructs; Learning environment (10), module (8), tutor (8), myVLE (6), 3 items for Satisfaction, Trust (4), Emotional Commitment (4) and Loyalty (5). The items were retained in each factor and were included in the final model. The study renames the respective constructs and determines the reliability by computing the Cronbach's Alpha to ensure the data are parsimoniously fit and clean for further analysis. Reliability Cronbach's alpha coefficients are above the minimum threshold of 0.70 recommended by Nunnally (1978) as shown in Table 1. The standardised factor loadings of all items are higher than 0.5 and reliability coefficient of all the constructs are higher than 0.7 which imply construct validity of the measurement model.

Table 1: Reliability Statistics for Constructs in the Model

	Cronbach's Alpha	Number of Items
Quality Enviroment	.917	10
Quality Tutor	.920	8
Quality Module	.919	8
Quality MyVLE	.916	6
Satisfaction	.914	3
Emotional Commitment	.918	4
Trust	.914	4
Loyalty	.925	5

The Measurement Model

CFA using IBM SPSS AMOS Version 22 was conducted to test the measurement model which is shown in Figure 2. The results show acceptable goodness-of-fit indices (Kline, 1998). Altogether the measures suggest a good model fit. The Chi-Square (χ^2) value of 3296.458 and the degree of freedom at 1009 yield the CMIN/df value of 3.267, which is below the threshold of 5 indicating good fit. The other important indices are the Comparative Fit Index (CFI) and Root Mean Square Error of Approximation (RMSEA). CFI of the measurement model is 0.979 (value above 0.9 indicates good fit) and RMSEA of the measurement model is 0.033 (value less than 0.07 indicates good fit; Hair et al,

2010). Hence it can be concluded that the measurement model is valid and has appropriate model fitness.

The Structural Model

The structural model (shown in Figure 3) is developed from the measurement model to replicate the proposed framework using path analysis. The acceptable method to achieve better fit is to free the paths that are not estimated in the model through the use of “modification indices” (Hair et al, 2010). However, there could be theoretical concern when the path is created. The best way to correlate the error terms within the same construct to minimize the theoretical concern of the issue (maintain unidimensionality). The structural model also has good fit; the CMIN/df value if 3.984 is less than 5. CFI of the structural model is 0.992 (above 0.9) and the RMSEA is 0.038 (less than 0.07). The fit indices show that the Student Loyalty Model achieves good fit.

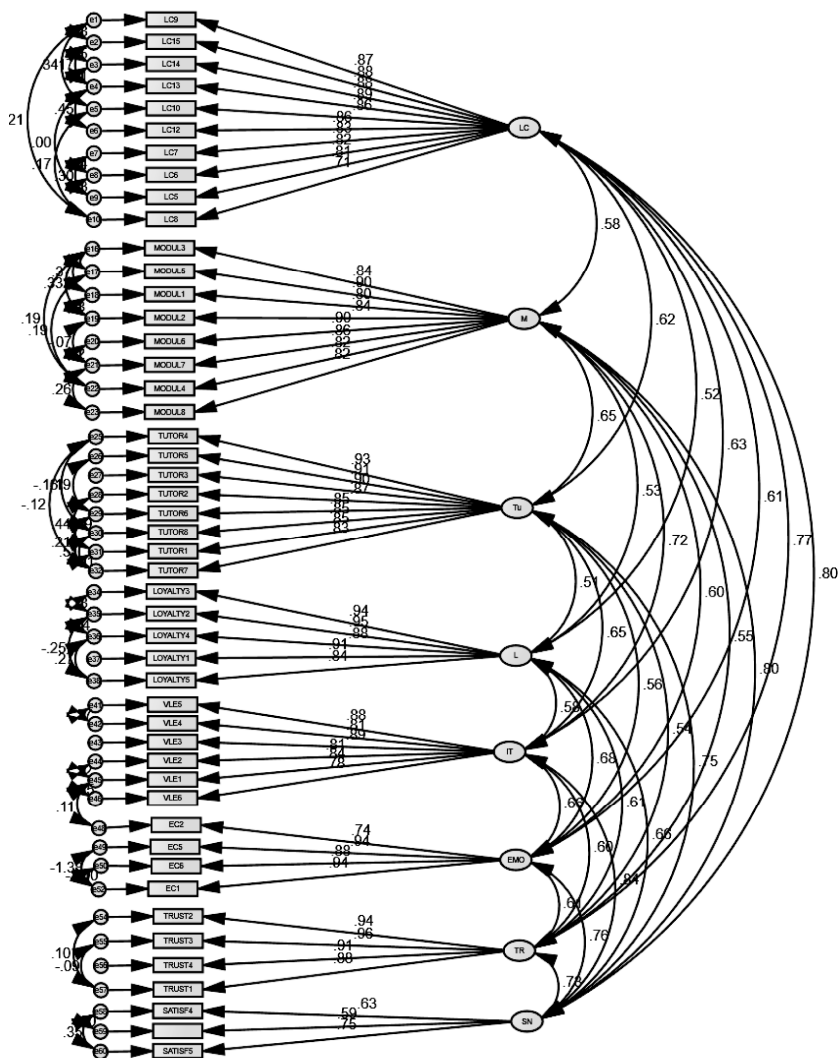

Figure 2: Measurement model of student loyalty model

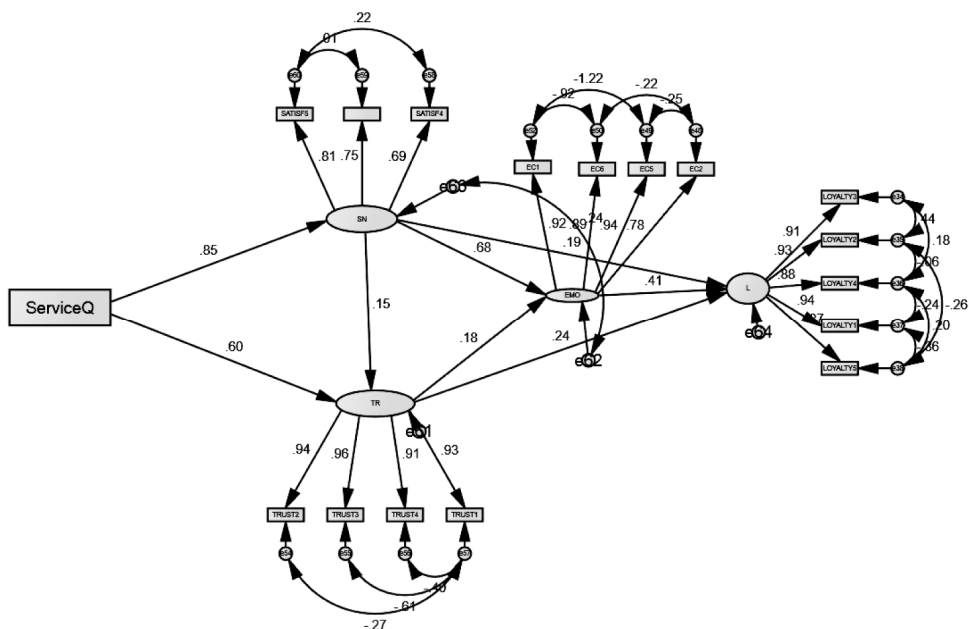

Figure 3: The student loyalty model

To test the proposed hypotheses from the framework, the path estimates between constructs in the Student Loyalty Model were calculated. Table 2 shows the path coefficients (the standardized regression weights), the p-value (testing of significance) and the R-Square (R² or the squared multiple correlations) of constructs).

Table 2 displays the hypothesized path coefficients. The present path analysis focused on the predictors of student loyalty in an open distance learning institution engaged during the academic calendar. The predictors, satisfaction, service quality, emotional commitment and trust were configured into the hypothesized model in Figure 3. The model was evaluated via IBM SPSS AMOS Version 22 (Arbuckle, 2010). The chi-square assessing model fit, with a value of 0.197 (1, N=2068), $p=0.657$, was not statistically significant; thus the model appeared to be a good fit to the data. The goodness-of-fit index (GFI), the normed fit index (NFI), and the comparative fit index (CFI) all yielded values of 1.000 and the obtained RMSEA value was 0.001 with 90% confidence interval of 0.000 to 0.045. All of these fit indexes indicated that the model was an excellent fit to the data.

The path coefficients are displayed in Figure 3 and summarised in Table 2. Table 2 showed that the model was able to account for 65% of the variance of student loyalty, which is largely due to the direct effect of trust and emotional commitment on loyalty.

Table 2: Summary of Total Effects, Direct Effects and Indirect Effects of the Path Determinants

	Determinants	Direct Effect	Indirect Effect	Total Effect	Sig. of Indirect Effect
Satisfaction R²=0.65	Service Quality	0.809	-	0.809	-
Trust R²=0.59	Service Quality	0.602	0.158	0.760	Yes
	Satisfaction	0.195	-	0.195	-
Emotional Commitment R²=0.55	Service Quality	0.323	0.381	0.704	Yes
	Satisfaction	0.185	0.059	0.254	-
	Trust	0.305	-	0.305	-
Loyalty R²=0.65	Satisfaction	0.070	0.167	0.237	Yes
	Trust	0.377	0.116	0.493	Yes
	Emotional Commitment	0.381	-	0.381	-
	Service Quality	-	0.612	0.612	Yes

CONCLUSION

The study was conducted to examine the relationships amongst the constructs in the Student Loyalty Model, namely satisfaction, trust, emotional commitment, service quality and loyalty. The findings of the study support the literature that service quality is the antecedent to student satisfaction and the consequences of student loyalty. The study develops a structural model of student loyalty and shows that educational service quality, satisfaction, trust, emotional commitment are the key determinants of student loyalty. It also adds to the growing body of knowledge pertaining to education, marketing and improvement of student loyalty and retention in open and distance learning (ODL) institutions. Allocating efforts and distributing investments on antecedents of this study are likely to end up with relatively increased student loyalty. Educationists and administrators of both ODL and non-ODL institutions can also use the information obtained for student enrolment management. The study also provides an empirical evidence of the application of the relationship marketing approach in managing student loyalty (albeit student retention) in an ODL institution.

REFERENCES

- Athiyaman, A. (1997). "Linking student satisfaction and service quality perceptions: The case of university education." *European Journal of Marketing*, 31(7/8), 528-540.
- Bean, J. P. and Metzner, B. (1985). "A Conceptual Model of Nontraditional Undergraduate Student Attrition." *Review of Educational Research*, 55 (4), 485-540.

- Berger, J. B. and Lyon, S. C. (2005). "College student retention: formula for student success." In *Past to present: a historic look at retention*. Seidman, A. (Ed.). Westport: Greenwood Publishing Group.
- Boulding, W., Kalra, A., Staelin, R. and Zeithaml, V. (1993). "A dynamic process model of service quality: form expectations to behavioral intentions", *Journal of Marketing Research*, Vol. 30, pp. 7-27.
- Bourner, T. (2011). "Action Learning over time: an ipsative enquiry." *Action Learning: Research and Practice*. Vol. 8, No. 1, March 2011, 43–56.
- Crosby, Lawrence A., Kenneth R. Evans, and Deborah Cowles. (1990). "Relationship Quality in Services Selling: An Interpersonal Influence Perspective," *Journal of Marketing*, 54 (July), 68-81.
- Doney, Patricia M. and Joseph P. Cannon. (1997). "An Examination of the Nature of Trust in Buyer-Seller Relationships", *Journal of Marketing*, 61 (April), 35-51.
- Du Plessis, L. (2010). *Customer relationship management and its influence on customer loyalty at Liberty Life in South Africa*, University of Johannesburg
- Fullerton, G. (2003). "When does commitment lead to loyalty?" *Journal of Service Research* 5(4):333-44.
- Garbarino, Ellen and Mark S. Johnson. (1999). "The Different Roles of Satisfaction, Trust, and Commitment in Customer Relationships," *Journal of Marketing*, 63 (April), 70-87.
- Grubb, W. N. (1989a). *Access, Achievement, Completion, and "Milling around" in Post Secondary Vocational Education*. Berkeley, CA: MPR Associates.
- Grubb, W. N. (1989b). "The effects of differentiation on educational attainment: The case of community colleges." *Review of Higher Education*, 12(4), 349–374.
- Hair, J.F., Black, W.C., Babin, B.J., and Anderson, R.E. (2010). *Multivariate Data Analysis*. Seventh Edition. Prentice Hall, Upper Saddle River, New Jersey.
- Arbuckle, J.L. (2010). *IBM SPSS Amos 19 User's Guide*. Chicago, IL: IBM.
- Hennig-Thurau, T. and Alexander, K. (1997). "The impact of customer satisfaction and relationship quality on customer retention: a critical reassessment and model development." *Psychology & Marketing*, v.14, n.8, p.737-764.
- Herzog, Serge. (2005). "Measuring Determinants of Student Return vs. Dropout/Stopout vs. transfer: A First to Second Year Analysis of New Freshmen." *Research in Higher Education*. Vol 46 No 8.
- Kotler, P. (1982). *Marketing for Non-profit Organisations*. Prentice Hall, 2nd Edition.
- Morgan, R. and Hunt, S. (1994). "The commitment-trust theory of relationship marketing." *Journal of Marketing*. Vol. 58. No 3, pp. 20-38.

- Mouzas, Stefanos, Stephan Henneberg and Peter Naudé. (2007). "Trust and Reliance in Business Relationships." *European Journal of Marketing*, 41 (9/10), 1016-32. Milliken, B.
- Oliver, R.L. (2007). *Satisfaction: A behavioral perspective on the consumer*. New York: McGraw-Hill.
- Palmer, Adrian and David Bejou. (1995). "The effects of gender on the development of relationships between clients and financial advisers," *The International Journal of Bank Marketing*, 13 (3), 18.
- Pausits, A. and Pellert, A. (2007). *Higher Education Development in Central, Souther and Eastern Europe*. New York. Munchen Berlin. Waxmann.
- Pritchard, M. P., Havitz, M. E. and Howard, D. R. (1999). "Analyzing the Commitment-Loyalty Link in Service Contexts." *Journal of the Academy of Marketing Science*. 27(3), 333-348 (1999)
- Schwartzman, J.O. (2003). *Funding of higher education institutions in Brazil*. Institute of Advanced Studies, University of São Paulo.
- Sheth, J. N. and Mittal, B. (2004). *Customer Behavior: A Managerial Perspective*, 2nd ed. Thomson South-Western.
- Sheth, J. N., and A. Parvatiyar. (1995). "The evolution of relationship marketing." *International Business Review*. 4 (4): 397-418
- Suh, J., & Yi, Y. (2006). "When brand attitudes affect the customer satisfaction-loyalty relation: The moderating role of product involvement." *Journal of Consumer Psychology*, 16(2), 145-155.
- Tierney, W. G. (1992). "An anthropological analysis of student participation in college." *Journal of Higher Education*, 63(6), 603-618.
- Tinto, V. (1975). "Drop-out from Higher Education: A theoretical synthesis of recent research." *Review of Educational Research*. Vol. 45, 89 - 125.
- Tinto, V. (1993). *Leaving college: Rethinking the causes and cures of student attrition*. (2nd ed.). Chicago: University of Chicago Press.
- Wong, A., Sohal, A. (2002). "An examination of the relationship between trust, commitment and relationship quality." *International Journal of Retail & Distribution Management*. 30 (1), 34-50.
- Xu, Y., Goedegebuure, R., and van der Heijden, B. (2006). "Customer perception, customer satisfaction, and customer loyalty within the Chinese securities business: Towards a mediation model for predicting customer behavior." *Journal of Relationship Marketing*, 5(4), 79-104.