

Combustion and emission analysis of fishing - boat diesel engine running on diesel-ethanol-biodiesel-ceria-alumina nano blends

D. Somasundaram¹, A. Elango² & S. Karthikeyan³

^{1,3}Department of Mechanical Engineering, Syed Ammal Engineering College, Ramanathapuram, India.

²Department of Mechanical Engineering, Alagappa Chettiar College of Engineering and Technology, Karaikudi, India.

¹ [E.mail: sompras123@yahoo.co.in]

Received 05 January 2017 ; revised 10 February 2017

It is found that the stability of diesel-ethanol blends improved with the addition of canola oil biodiesel. Heat Release Rate (HRR) and cylinder pressure were found to increase with the increase in ceria-alumina nanoparticle concentration. Also emission of Hydrocarbon (HC), Carbon monoxide (CO), Oxides of nitrogen (NO_x), smoke opacity and Carbon di-oxide (CO₂) decreased with the increase in ceria-alumina nanoparticles concentration.

[**Keywords:** Fishing-boat, Ethanol, Emission, Ceria-Alumina]

Introduction

The compression ignition engines are generally used in fishing boats due to its dependable operation and economy. The stringent government regulation and global warming made the engine producers and the users to obey the emission norms to prevent environmental pollution. Ethanol and biodiesel are considered as most desired fuel additives due to their high oxygen content and being renewable. Phase separation is a major obstacle with the blending techniques among the limitations of blending ethanol with diesel.

The molecular association and bonding created by co-solvents through a uniform blend are confirmed by various researchers from their stability studies of diesel ethanol blends with additives¹⁻⁵. The action of cerium oxide additive on diesel emissions and oxidation kinetics was studied⁶. They found that when the cerium oxide is added to diesel, there were substantial drop in light-off temperature and significant increase in the oxidation rate.

The structural characterization of a cerium-Zirconium mixed oxide supported Manganese oxide and also its catalytic activity in the oxidation of particulate matter arising from diesel engines was studied⁷. The complexity of the ethanol

reactions on the surfaces of cerium oxide was studied⁸. From the test to improve the combustion of diesel fuel and the influence of size and quantity of aluminum and nano aluminum oxide in a diesel fuel ignition, it was concluded that the ignition delay shortened and the ignition chances of diesel increased⁹.

Finally, it was determined that, the increase in heat and mass transfer properties of the fuel would reduce the evaporation time of droplets¹⁰. Aluminum has better combustion energies and has been used as an energetic additive in propellants and explosives¹¹. Since metal nanoparticles have great specific surface area, they provide shortened ignition delays, and better complete combustion than micron sized particles¹².

The present work is a nascent attempt to improve emission reduction capabilities of a diesel-biodiesel-ethanol blends by ceria-alumina oxide nanoparticles as fuel additive along with the use of canola oil methyl esters as a co-solvent to enhance blend stability on the fishing boat diesel engine.

Materials and Methods

The test engine used is kirloskar (7 kW) and its specifications are shown in Table 1. This engine type is the most widely used for fishing

boats in and around our coastal regions
 Figure 1 shows a schematic diagram of the experimental set-up. NO_x, HC, CO, and CO₂ were measured online using an exhaust gas analyzer (AVL Five-gas analyzer). Smoke density was measured with the help of an AVL smoke meter. The combustion characteristics of the engine are measured using the AVL combustion analyzer.

Preparation of Fuel Blends

Table 1- Specification of the test Engine

Type	Vertical, Water cooled, Four
Number of cylinder	One
Bore	87.5 mm
Stroke	110 mm
Compression ratio	17.5:1
Maximum power	5.2 kW
Speed	1500 rpm
Injection timing	23° before TDC
Injection pressure	220 kgf/cm ²

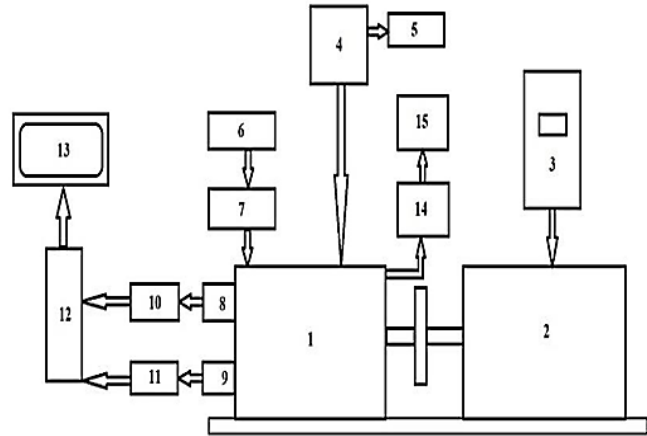

1.Diesel Engine; 2.Eddy Current Dynamometer; 3.Dynamometer Controls; 4.Air Box; 5. U-Tube Manometer; 6.Fuel Tank; 7.Fuel measurement flask; 8.Pressure pick-up; 9.TDC Position Sensor; 10.Charge Amplifier; 11.TDC Amplifier Circuit; 11.A/D Card; 13.Personal Computer; 14.Exhaust Analyser; 15.AVL Smoke Meter

Figure 1. Schematic diagram of the Experimental Setup

Table 2- Properties of the fuel blends.

Properties	Diesel	Ethanol	Canola oil	D45E45B10	D45E45B10 +50ppm	D45E45B10 +75ppm	D45E45B10 +100ppm
Kinematic Viscosity @ 40°C,cSt	2	1.13	5.38	2.35	2.35	2.35	2.35
Density @ 15°C, gm/cc	0.83	0.79	0.89	0.83	0.83	0.83	0.83
Flash Point, °C	50	13.50	172	11	11	11	11
Fire Point, °C	56	-	186	14	14	14	14
Cetane Number	46	6	48	44	45	47	48
Net calorific value, MJ/kg	42.30	25.18	38.75	39	39	40	42

The diesel fuel employed in the tests was commercial and obtained locally. Analysis-grade anhydrous ethanol (99.7% pure) was used. The alumina nanoparticles with an average size of 30 nm are supplied by the manufacturer; M/s. Sisco Research Laboratories, Mumbai and Ceria nano particle with an average size of 80 nm are supplied by the manufacturer/s. Zigma Aldrich.

Normally doping is a process of adding impurities with some pure materials to utilize the useful properties of both materials. Here aluminum oxide having a high energy density is doped with ceria nanoparticles having a higher oxidation rate is the fuel additive in this investigation. The concentration of the ceria-alumina nanoparticle samples (by weight) in the fuel blend was varied from 50 to 100 ppm.

In the present study, four blends of fuels were prepared such as D45E45B10, D45E45B10 + 50 ppm, D45E45B10 + 75 ppm, D45E45B10 + 100 ppm respectively. After a set of trials, when the blends subjected to high speed blending followed by ultra-sonication, the stability is found to be increased. Table 2 shows the salient properties of the fuel blends.

Results and Discussions

This section explains the results obtained from the combustion and emission characteristics of the Compression Ignition (CI) engine. The smoke density variation with engine load for various blends is shown in Figure 2. The figure indicates that up to 70% of load smoke level increases and then gradually decreases for all the concentrations.

It is observed that the smoke density of all the blends is lower than that of D45E45B10 at maximum load. The smoke density is lowest for D45E45B10 + 100 ppm compared to other blends. The maximum smoke density recorded for the D45E45B10 was 38 Hartridge Smoke Unit (HSU). As a result of oxygen enrichment by D45E45B10 + 100 ppm, fuel evaporation is contained during diffusion combustion which subsequently reduces the smokedensity¹³.

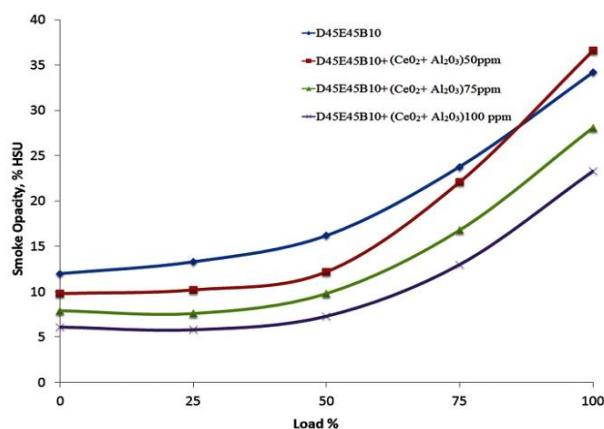

Figure 2. Variation of smoke opacity with load

Oxygen emission variations are shown in Figure 3 for various blends at different engine loads. The oxygen emissions from nano blended fuels were considerably lower than that of blend without nanoparticles. Some researchers think that when the engine speed increases, oxygen in ceria-alumina nanoparticles contributes significantly to reactions of oxygen-fuel in the engine cylinder.

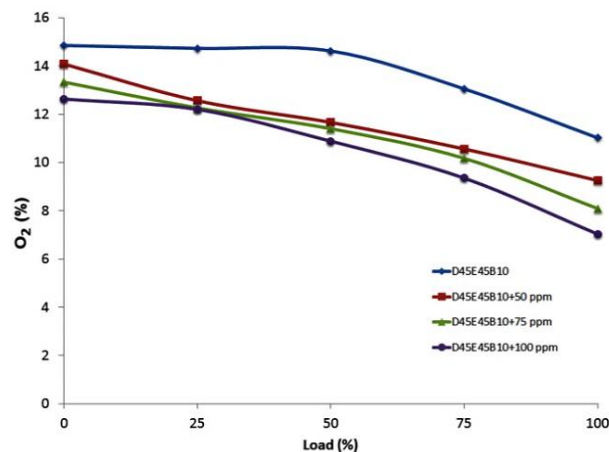

Figure 3. Variation of oxygen with load

The chemically bound oxygen in the ceria-alumina provided another excess source of the oxygen component, which added excess inlet air to the burning reactant mixture with the catalytic action of ceria-alumina nanoparticles. Hence, burning of the diesel-biodiesel-ethanol blends which normally produce more residual oxygen emissions is reduced¹⁴.

Cylinder pressure variation with crank angle is shown in Figure 4. It is found that with the addition of ceria-alumina nanoparticles in diesel-biodiesel-ethanol, peak pressure increases. The addition of ceria-alumina nano particles with diesel-biodiesel-ethanol blends accelerates the initiation of combustion.

As more fuel is accumulated in the premixed combustion regime, a quick combustion is caused which results in higher peak pressure¹⁵. It is found that maximum peak pressure is 68 bar for the D45E45B10 + 100 ppm blend, whereas is 62 bar for D45E45B10.

This is may be due to the shorter delay period of fuel blends with ceria-alumina nanoparticles concentration. The shorter delay period is mainly due to sudden vaporization of ceria-alumina nanoparticles, which helps to improve combustion temperature¹⁶. The HRR variation with crank angle is shown in Figure 5. The heat release rate increases with the addition of ceria-alumina nanoparticles in diesel-biodiesel-ethanol. The longer ignition delay due to the addition of ethanol is offset by rapid combustion in the premixed phase by the addition of nanoparticles resulting in higher HRR.

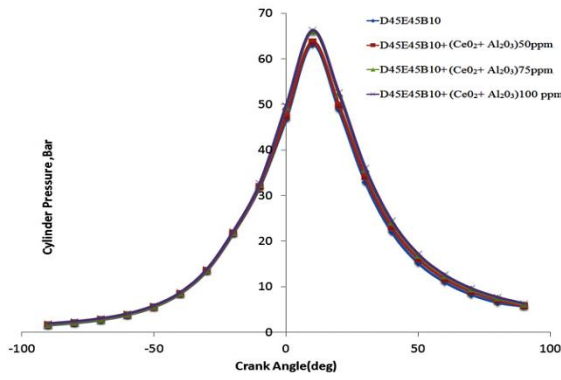

Figure.4. Variation of cylinder pressure with load

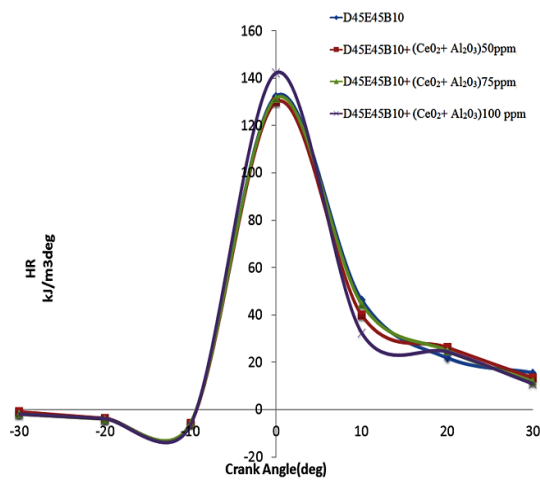

Figure 5. Variation of HRR with load

The ceria-alumina nanoparticles addition also accelerates combustion, which enhances the heat release rate when compared with diesel-biodiesel-ethanol blend. The maximum heat release rate is observed as 140KJ/m³deg for the D45E45B10 + 100 ppm blend at Top Dead Centre (TDC), whereas it is 120KJ/m³deg for D45E45B10¹⁷. Carbon monoxide variation with load is shown in Figure 6. The emission of carbon monoxide decreases with the use of ceria-alumina nanoparticles in diesel-biodiesel-ethanol blends.

Moreover the addition of ceria-alumina decreases the CO emission when compared with diesel-biodiesel-ethanol blend eliminating green house effect in the atmosphere. This could be due to the improved surface area–volume ratio and enhanced ignition properties of nanoparticles which initiate the early combustion¹⁸.

The CO₂ emissions of the diesel engine fuelled with the diesel-biodiesel-ethanol blends

with and without ceria-alumina nanoparticles are shown in Figure 7.

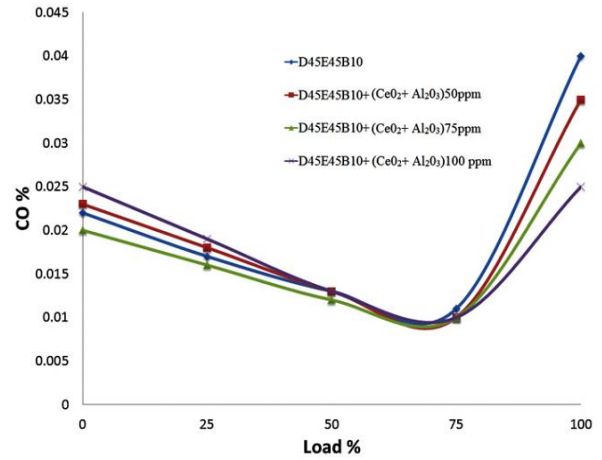

Figure 6. Variation of CO with load

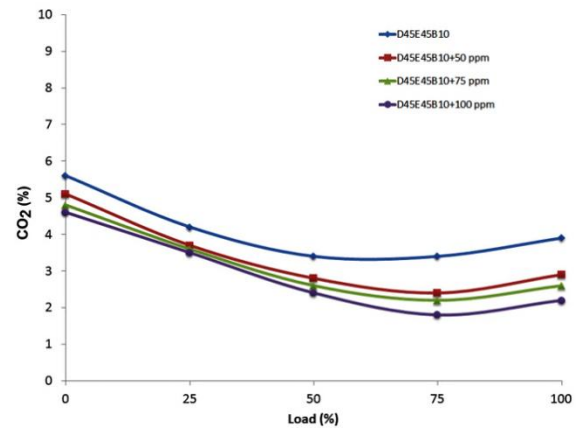

Figure 7. Variation of CO₂ with load

The CO₂ emissions resulting from D45E45B10 + 100 ppm were lower than that of D45E45B10. However, the differences were not considerably high. The average CO₂ decrease for D45E45B10 + 100 ppm was 4.57% at all engine loads. The hydrocarbon variation with load is shown in Figure 8.

The use of ceria-alumina nano particles in oxygenated blends reduces hydrocarbon emission by means of complete combustion¹⁹. Least hydrocarbon emission is observed as 46 ppm for the D45E45B10 + 100 ppm blend at the 50 % load.

The nitrogen oxide variation with load is shown in Figure 9. Nitrogen oxide emission is lower for the diesel-biodiesel-ethanol blends when compared to blends with ceria-alumina nanoparticles.

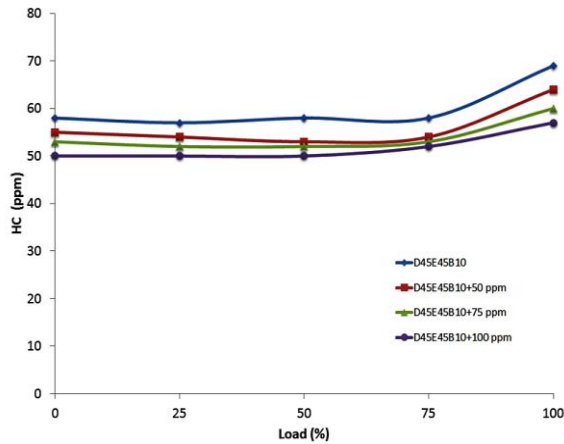

Figure 8. Variation of HC with load

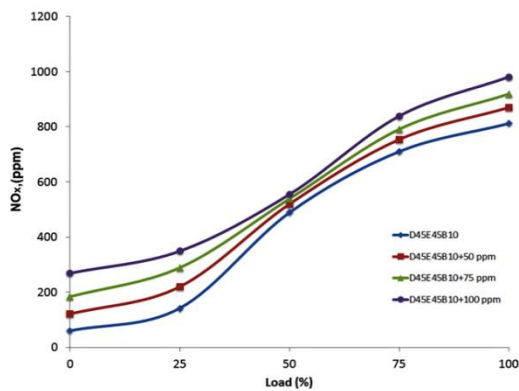

Figure 9. Variation of NOx with load

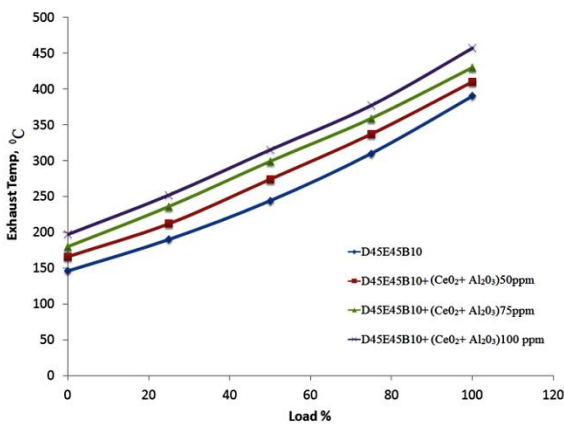

Figure 10. Variation of Exhaust Temperature with load

The effect of ceria-alumina nanoparticles enhances combustion along with the longer ignition delay due to the ethanol addition results in faster premixed combustion, which causes higher combustion temperature and the subsequent higher nitrogen oxide emission²⁰.

It is noted that nitrogen oxide emission increases with addition of ceria-alumina nanoparticles than diesel-biodiesel-ethanol blends. However, nitrogen oxide emission of the blends marginally increases for the entire range of test conditions. The least NO is observed as 780 ppm for diesel-biodiesel-ethanol blends at the 50% load. It can be clearly seen from the heat release graph. These results of higher nitrogen oxide emissions for nano blends can be supported with Figure 10, which shows higher exhaust gas temperature for diesel-biodiesel-ethanol blends with ceria-alumina nanoparticles.

Conclusion

It can be concluded that the peak pressure and heat release rate increases with the blending of cerium-alumina nanoparticles with ethanol-biodiesel in diesel. Carbon monoxide emission decreases with the use of cerium-alumina nanoparticles in diesel-biodiesel-ethanol blends. The nitrogen oxide emission is lower for the diesel-biodiesel-ethanol blends than the nano blends. Smoke decreases with the fuel blends with oxygenated additives like cerium-alumina nanoparticles.

Acknowledgement

The authors are thankful to the research centre of Alagappa Chettiar College of Engineering and Technology, Karaikudi to carry out this research work.

References

- 1 Prommes, K., ApaneeL, M., Samai, J., Solubility of a Diesel-Biodiesel-Ethanol Blend, Its Fuel Properties, and Its Emission Characteristics from Diesel Engine, *Fuel.*, 86(2007): 1053-1061.
- 2 Magin, L., Octavio, A., Reyes, G.C., Stability of diesel-bioethanol blends for use in diesel engines, *Fuel.*, 86(2007): 1351-1357.
- 3 Arul MozhiSelvan, V., Anand, R.B., Udayakumar, M., Stability of Diesohol blend with castor oil as additive and its performance and emission characteristics in a variable compression ratio engine, *Proc. National conf. on Energy Security for Rural Development.*, India, (2009): 110-112.
- 4 Arul MozhiSelvan, V., Anand, R.B., Udayakumar, M., Stability and Performance Characteristics of Diesohol Using Biodiesel as Additive in Compression Ignition Engine, *Proc. Inter. Conf. on Fascinating Advances in Mechanical Engineering.*, India, 32(2008).
- 5 Heejung, J., David, B., Kittelson, H., Michael Zachariah, R., The influence of a cerium additive on ultrafine diesel particulate emissions and kinetics of oxidation, *Combustion Flame.*, 142(2005): 276-288.

- 6 Sanchez Escribano, V., Fernandez Lopez, E., GallardoAmores, J.M., HoyoMartínez, C., Pistarino, C., Panizza, M., Resini, C., Buscac, G., A study of aceria-zirconia-supported manganese oxide catalyst for combustion of Diesel soot particles, *Combustion Flame.*, 153(2008): 97- 104.
- 7 Idriss, H., Ethanol Reactions over the surface of Noble Metal/Cerium Oxide catalysts, *Platinum metals Rev.*, 48(2004): 105-115.
- 8 Tyagi, H., Phelan, P.E., Prasher, R., Increased hot-plate ignition probability for nanoparticle-laden diesel fuel, *Nano Lett.*, 8(2008):1410–1416.
- 9 Yatter, R.A., Rishaand, G.A., Son, S.F., Metal particle combustion and nanotechnology, *Proc. Combustion Institute.*, 32(2009):1819–1838.
- 10 Dreizin, E.L, Metal-based reactive nanomaterials, *Prog. Energy Combustion Science.*, 35 (2009): 141–167.
- 11 Granier, J.J., Pantoya, M.L., Laser ignition of nanocomposite thermites, *Combustion Flame.*, 138 (2004): 373–383.
- 12 Beloni, E., Hoffmann, V.K., Dreizin, E.L., Combustion of Decane-Based Slurries with Metallic Fuel Additives, *J. Propul. Power.*, 24 (2008): 1403–1411.
- 13 Dlott, D.D., Thinking big (and small) about energetic materials, *Mater. Sci. Tech Ser.*, 22 (2006): 463–473.
- 14 Sajith, V., Siobhanand, C.B., Peterson, G.P., Experimental Investigations on the Effects of Cerium Oxide Nanoparticle Fuel Additives on Biodiesel, *Advances in Mechanical Engineering.*, 2010(2010): 1-6.
- 15 Lahaye, J., Boehm, S., Chambrion, P.H., Ehrburger, P., Influence of cerium oxide on the formation and oxidation of soot, *Combustion Flame.*, 104(1996): 199–207.
- 16 Venkatesan, S.P., Kadires, P.N., Influence of an aqueous cerium oxide nanofluid fuel additive on performance and emission characteristics of a compression ignition engine, *Inter. J. Ambient Energy.*, 37(2016): 64-67.
- 17 Arul MozhiSelvan, V., Anand, R.B., Udayakumar, M., Effects of cerium oxide nanoparticle addition in diesel and diesel-biodieselethanol blends on the performance and emission characteristics of a CI engine, *ARPJ: J. Eng. Appl. Sci.*, 4(2009): 1-6.
- 18 Masoumeh, H., Mehdi, A., Meisam, T., Experimental investigation of the effect of cerium oxide nanoparticles as a combustion-improving additive on biodiesel oxidative stability, *Mechanism RSC Adv.*, 4(2014): 14352–14356.
- 19 SathikBasha, J., Anand, R.B., Effects of Alumina Nanoparticles Blended Jatropha Biodiesel Fuel on Working Characteristics of a Diesel Engine, *Inter. J. Indust. Engg. and Tech.*, 2(2011): 53-62.
- 20 Karthikeyan, S., Elango, A., Silaimani, S.M., Prathima, A., Role of Al₂O₃ nano additive in GSO biodiesel on the working characteristics a CI engine, *Indian J. Chem. Techn.*, 21(2014): 285-289.

Nomenclature

D45E45B10	Diesel 45% + Ethanol 45% + Bio- Diesel 10%
D45E45B10+50 ppm	Diesel 45%+Ethanol 45%+Bio-Diesel 10%+50 ppm of Ceria - alumina
D45E45B10+75 ppm	Diesel 45%+Ethanol 45%+Bio-Diesel 10%+75 ppm of Ceria - alumina
D45E45B10+100 ppm	Diesel 45%+Ethanol 45%+Bio-Diesel 10%+100 ppm of Ceria-alumina
HC	Hydrocarbon
NO _x	Oxides of nitrogen
CO	Carbon monoxide
CO ₂	Carbon di-oxide
rpm	Revolution per minute
ppm	Parts per million
HSU	Hartridge Smoke Unit
HRR	Heat Release Rate
TDC	Top Dead Centre
CI	Compression Ignition
Nm	Nanometer
KJ	KiloJoules
m ³	Cubic meter
deg	Degree