

Doc vs Internet

96.73% Originality	3.27% Similarity	39 Sources
--------------------	------------------	------------

Web sources: 39 sources found

1. http://mobile.repository.polnep.ac.id/xmlui/bitstream/handle/123456789/71/07-Marzuki%20Rusman...	0.68%
2. https://www.slideshare.net/andrys1/audit-energy-andry-swantana	0.5%
3. http://journal.um.ac.id/index.php/tekno/article/download/4669/3892	0.41%
4. http://ojs.serambimekkah.ac.id/index.php/jse/article/view/354	0.41%
5. https://core.ac.uk/download/pdf/80820127.pdf	0.35%
6. https://www.intechopen.com/books/wireless-sensor-networks-technology-and-protocols/overview-o...	0.29%
7. http://www.freepatentsonline.com/8976704.html	0.29%
8. https://docplayer.net/76950358-V-naukovo-praktichna-konferenciya-studentiv-ta-aspirantiv-prisvyac..	0.29%
9. https://www.slideshare.net/GaneshKhadsan/wireless-sensor-network-report	0.29%
10. https://www.engineersgarage.com/articles/humidity-sensor	0.29%
11. https://www.slideshare.net/darpan_dekivadiya/routing-protocols-for-wireless-sensor-networks	0.29%
12. https://isindexing.com/isi/searchedpapers.php?page=6550&limit=50	0.29%
13. https://www.studymode.com/topic/Wireless	0.29%
14. https://muxindia.wordpress.com	0.29%
15. https://www.science.gov/topicpages/u/unreliable+sensor+networks.html	0.29%
16. http://mobilenetworksworld.blogspot.com/2009/06	0.29%
17. https://moodle.utc.fr/file.php/498/Articles/A9.pdf	0.29%
18. https://www.studymode.com/subjects/most-reliable-network-topology-page1.html	0.29%
19. http://isindexing.com/isi/searchedpapers.php?page=12540&limit=20	0.29%
20. https://www.readkong.com/page/internet-of-things-iot-business-opportunities-value-6891659	0.29%
21. https://www.slideshare.net/darpan_dekivadiya/routing-protocols-in-wsn	0.29%
22. https://www.science.gov/topicpages/s/sensor+networks+bsn.html	0.29%
23. http://isindexing.com/isi/searchedpapers.php?page=7600&limit=50	0.24%
24. https://basicknowledge101.com/categories/artificialintelligence.html	0.24%
25. https://www.tut.ac.za/s-faculties/engineering/Shared%20Documents/2019/2019_In_Perspective_...	0.24%
26. https://isindexing.com/isi/searchedpapers.php?page=27400&limit=50	0.24%
27. https://jessicasiboro.blogspot.com/2019/01	0.24%
28. https://www.turkaramamotoru.com/en/wireless-sensor-network-26871.html	0.24%
29. http://www.wright.edu/~guy.vandegrift/openstaxphysics/chaps/14%20Heat%20transfer.pdf	0.24%
30. https://isindexing.com/isi/searchedpapers.php?page=16350&limit=50	0.24%
31. http://techblog.comsoc.org/category/iot/page/3	0.24%
32. https://www.popehat.com/2018/07/10/youll-hate-this-post-on-brett-kavanaugh-and-free-speech	0.24%
33. http://jessicasiboro.blogspot.com/2018/04/linear-power-supply-and-switch-short.html	0.24%
34. http://isindexing.com/isi/searchedpapers.php?page=0&limit=5	0.24%

35. https://link.springer.com/article/10.1186/s13174-018-0097-0	0.24%
36. http://www.physics-and-radio-electronics.com/electronic-devices-and-circuits/passive-component...	0.24%
37. http://www.ijeit.com/vol%202/Issue%2011/IJEIT1412201305_21.pdf	0.24%
38. http://ijarece.org/wp-content/uploads/2013/08/IJARECE-VOL-1-ISSUE-4-46-51.pdf	0.24%
39. https://en.wikipedia.org/wiki/Wireless_sensor_network	0.24%

 Similarity

 Similarity from a chosen source

 Possible character replacement

 Citation

 References

Preliminary Study of Utilizing Internet of Things for Monitoring Energy Use in Building to Support Energy Audit Process

Muhammad Priyono Tri Sulistyanto
 Department of Informatics
 Kanjuruhan University
 Malang, Indonesia
m.priyono.ts@unikama.ac.id

Kurriawan Budi Pranata¹, Solikhan²
 Department of Physics Education
 Kanjuruhan University
 Malang, Indonesia
1kurriawan@unikama.ac.id, 2solikhan@yahoo.com

Abstract—Energy conservation in building especially for energy audit process is integrated with wireless energy monitoring of each electronic equipment in a building to reduce energy user survey of each electronic equipment. Energy audit has objective not only for saving energy use but also reducing CO₂ emission. Energy audit also can analyze energy consumption intensity and identify energy saving opportunities. However process of energy audit does not take a short time, because initially it must be done by some procedures e.g. survey of energy management and detail survey of energy. The process time can be minimized by utilizing Internet of Things (IoT) to collect data of energy use in every electric appliances and integrating the information system of electronic energy audit to analyze energy use of building. This paper proposes the preliminary study of IoT combined with Wireless Sensor Network to support traditional energy audit process. Energy use data is monitored and collected in real time by IoT. Generally electronic appliances are located in several places, thus the data transmission from energy monitoring system uses wireless communication instead of wire communication. Every wireless IoT is sensor node in wireless sensor network that sends data to gateway/broker then finally send to server. The electronic energy audit is installed in this server to record data from every sensor node in real time and analyze energy saving opportunity. (Abstract)

Keywords—electronic energy audit; energy saving opportunity (ESO); Internet of Things (IoT); Wireless Sensor Network (WSN)

I. INTRODUCTION

Energy conservation researches through energy audit activities in buildings have been done by universities [1,2], but the process of measuring and checking on any electrical equipment does not take a little time because it must be surveyed to each location. This paper proposes an electronic energy audit system by designing a sensor system placed in the room and equipment to measure physical quantities that consume energy e.g. electric current, temperature, humidity, and light flux. The location of rooms and equipment is not adjacent as a result will make the monitoring process is not easy. The propose solution to monitor energy use of those components integrated Internet of Things [3], wireless sensor network [4] and energy audit information systems. Real time energy usage data from electronic and room equipment will be taken by sensor system and sent to the gateway host which is eventually forwarded to the server for further processing.

II. ENERGY AUDIT

Energy conservation is a systematic, planned and integrated effort to conserve domestic energy resources and improve the efficiency of its utilization [5] or in the general definition means activities to utilize energy efficiently and rationally without increasing the necessary energy usage [6]; therefore it can reduce energy costs. The purpose of energy conservation activities is to conserve natural through technology selection policy and utilization efficiently, rationally, and to realize the ability of energy supply.

The use of electrical energy in Indonesia is still not efficient thus affecting electricity supply especially in Java and Bali. Fig. 1 shows the energy efficiency index benchmark between Jakarta and Japan that energy consumption in Jakarta is the largest, therefore ESO can still be obtained [10]. Example of wasteful in buildings are the use of air conditioning and lights that remain turned on even though it is no longer necessary due to negligence or unfavorable habits.

One of the ways to realize energy savings is through energy audit activities [5] as energy efficiency verification in energy efficiency concept and finalization of total cost estimation through inspection, measurement and analysis of consumption and energy cost, and investment value in detail and systematically

Energy audit procedure in Indonesia is based on SNI (Standar Nasional Indonesia) or Indonesian National Standard [11]. This procedure is similar as AS/NZS 3598-2000 standard, whereas energy audit can be divided into three scheme i.e. Audit Energi Singkat (Brief Energy Audit/BEA) or Energy Audit level I; Audit Energi Awal (Preliminary Energy Audit/PEA) Energy Audit level II; and Audit Energi Rinci (Detail Energy Audit/DEA) Energy Audit level II [12].

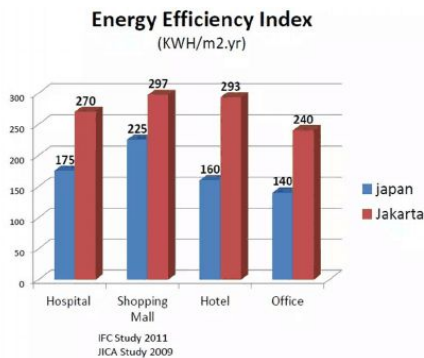

Fig. 1 Jakarta v.s Japan Energy Efficiency Indexes Comparison [10]

Fig. 2 shows overall procedure in Energy Audit. BEA is basically a survey of energy management that its aim to

investment decisions which affect the conservation project.

BEA process will stop if EUI calculation reaches the EUI standard that can be concluded energy use in building is efficient, otherwise energy audit can continue into PEA or DEA.

A. EUI (Energy Use Intensity)

Energy Use Intensity (EUI) states the amount of energy consumed in buildings and has been applied in various countries (ASEAN, APEC), expressed in kWh / m2 per month or per year [10]. The calculation of EUI can be shown in (1)

$$EUI = \frac{\text{Total energy consumption (month or year)} (kWh)}{\text{Total of building area} (m^2) \times \text{time} (month)}$$

Table 2 shows EUI Standard of buildings in Indonesia based on building type: If building has larger value than the standard, then there is an indication of energy wastage thus ESO can be achieved

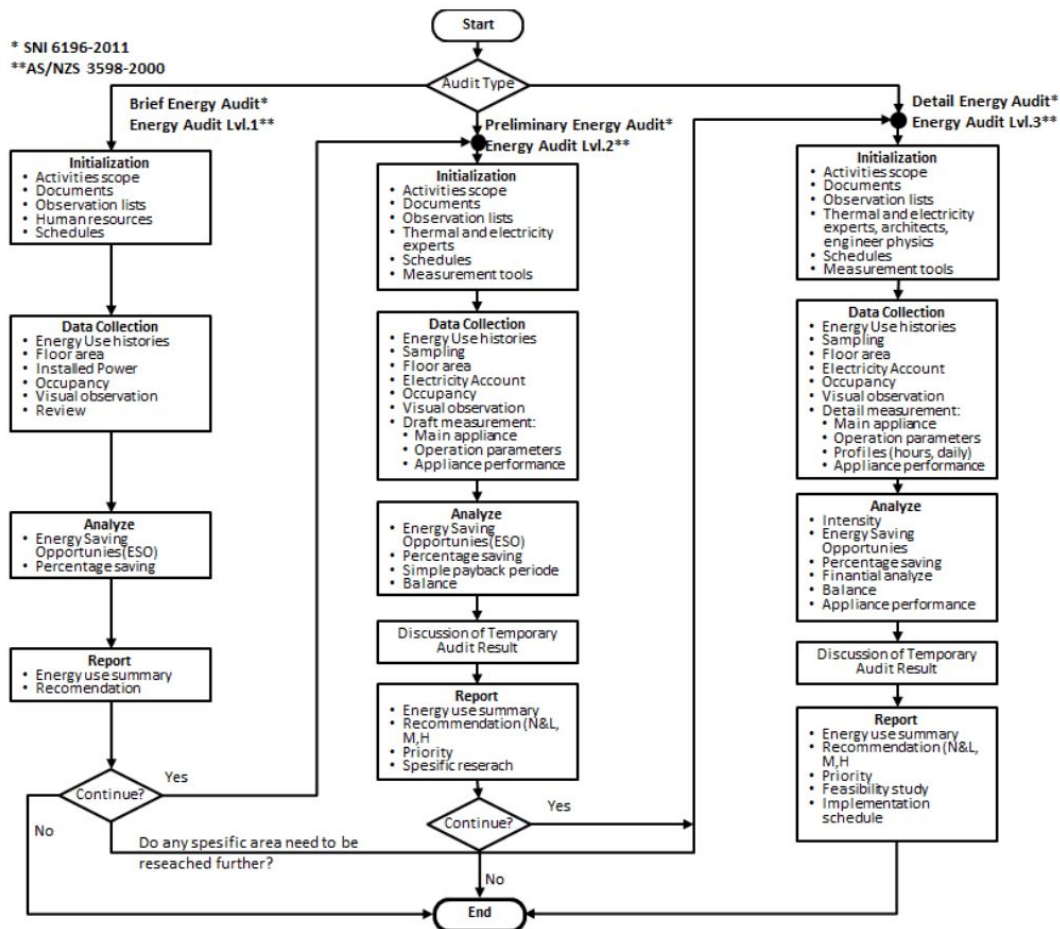

understand the management of ongoing activities and criteria of Fig. 2 Overall Common Energy Audit Process

Table 1. EUI Standard Value in Building (ASEAN USAID in 2004)

No	Building Type	EUI (kWh/m ² .yr)
1.	Office	240
2.	Store/Market	330
3.	Hotel	300
4.	Hospital	380

B. Air Conditioning

This system is the process of air cooling or heating to reach the desired temperature and humidity [12]. Human activities need comfort, especially desired air condition as shown in Fig. 3.

Fig. 3 explains about the comfort zone according to ASHRAE Standard 55 with temperatures ranging from 20C until 27C, and relative humidity ranges between 8% and 80%.

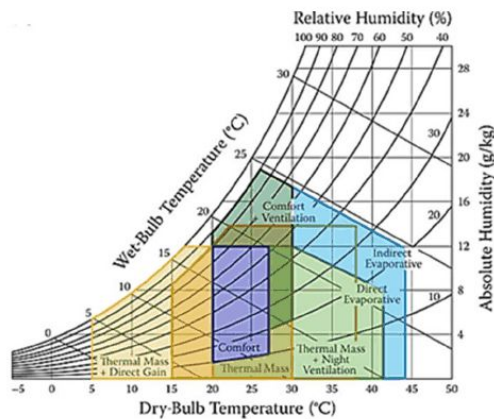

Fig. 3 Temperature Effective Standard and Comfort Zone [13]

C. Lighting System

Illumination or lighting system is a system that arranges exposure both natural and artificial. Physics quantities used in this system are Flux Luminous which is the rate of light emission or quantity of light produced by a light source expressed in Lumen; and Illumination which is the light emission rate (Lumen) and electric power used to produce light expressed by Lumen/watt or Lux.

III.M EASUREMENT OF ELECTRONIC ENERGY AUDIT

Measurement data in electronic energy audit can be electricity current, temperature, humidity and flux needs sensors or transducers that can measure those physics quantities.

A. Current Transformer (CT) sensor

Current transformer is one kind of transformers that used to measure alternating current. This sensor also will produce alternating current (Is) in secondary coil (Ns) that is proportional to alternating current (Ip) from primary coil or (Np) that can be shown in Fig 4(a). The primary coil is an iron core enclosing a

single cable, then the secondary current (Is) is $N1 / N2$ multiplied by the primary current (Ip), thus when N2 and primary current equal 2000 and 30A respectively then Is equals $30/2000$ A or 15mA . This signal needs to be conditioned so that it can be read on the microcontroller ADC by converting it into a voltage signal by providing a burden resistor (load resistance) as shown in Figure 3

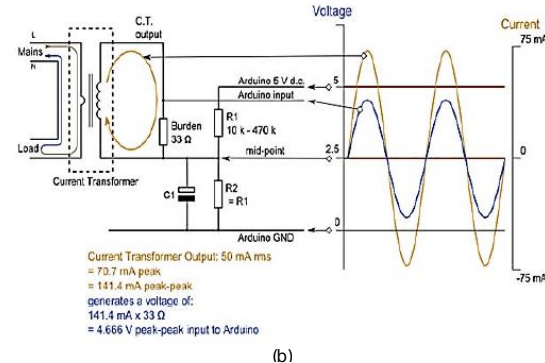
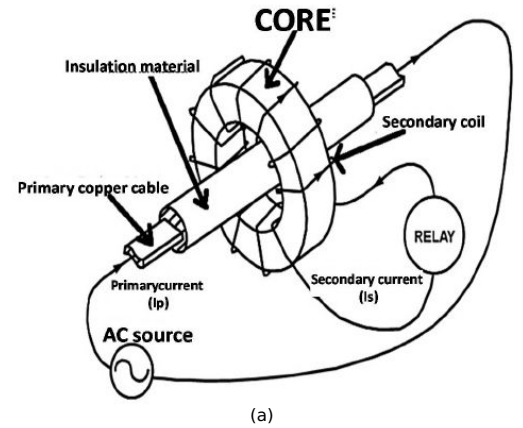

Fig. 4 Current transformer diagram, (a) Primary and secondary side schemes of current transformer [14], (b) Signal conditioning circuit to microcontroller ADC [15]

B. Temperature Sensor

Temperature Sensors is a component that can convert the amount of heat into electrical quantities thus it can detect temperature changes in object. This sensors senses the amount of heat / cold energy generated by an object allowing us to know or detect the symptoms of temperature changes in analog and digital outputs.

One type of temperature sensor used to measure room temperature is a thermistor (thermal resistor) that has temperature range from -90C until 130C. Thermistor is an electronics component whose resistance value is affected by temperature. Thermistor is basically consists of 2 types e.g. PTC (Positive Temperature Coefficient) whose resistance value will

increase high when the temperature is high and NTC (Negative Temperature Coefficient) whose resistance value decreases when the temperature increases that can be seen in Fig 5.

Nama Komponen	Gambar	Simbol
Thermistor PTC		 atau 
Thermistor NTC		 atau 

Fig. 5 Thermistor types of PTC and NTC and their symbols [16]

C. Humidity Sensor

Temperature Sensors is a component that can convert the amount of heat into electrical quantities thus it can detect temperature changes in object. This sensors senses the amount of heat / cold energy generated by an object allowing us to know or detect the symptoms of temperature changes in analog and digital outputs.

Humidity sensors can be applied to diverse uses in the HVAC (heating ventilation and air conditioning) sector. One type of humidity sensor is capacitive humidity sensor that implements the dielectric material phenomenon from electrode pair on capacitor. Capacitance value C is proportional to permittivity value ϵ and electrode area A, and inversely proportional to the distance between two electrodes d that is formulated in the equation $C = (\epsilon A) / d$ [17]. In the presence of moisture, the total dielectric value consisting of electrode material and vapor capacitance will change. Fig. 6 shows the dielectric humidity sensor scheme.

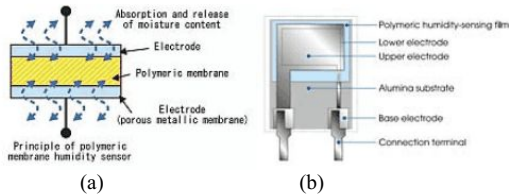

Fig. 6 Capacitive moisture sensor, (a) Pasteous sensitive material to moisture as a dielectric material, (b) sensor cross section of 2 electrodes with a dielectric material in the middle [17]

At normal room temperature, the dielectric constant of water vapor is about 80 which is greater than the constant of the dielectric material, therefore the absorption of vapor by the sensor will increase capacity. Examples of sensors for measuring moisture are DHT11, DHT22, SHT71, and so forth

D. Light Sensor

Light sensor is passive sensor used to determine the intensity of light by measuring radiation energy emitted within certain frequency range of wave. In the spectrum of electromagnetic

waves, the frequency range detected by the sensor is between infrared to ultraviolet (UV) frequencies.

The light sensor converts light energy of photons into electrical energy of electrons. This sensor is divided into two main types based on the physical quantity that influenced e.g. Photo Voltaic sensor and Photo Conductive sensor. Photo Voltaic Sensor produces voltage which depends on the amount of radiation from light coming from semiconductor material either in inorganic or organic form, while Photo Conductive sensor produces conductivity or resistivity caused by exposure of light. Examples of Photo Conductive sensor are LDR (light dependent resistor), Photo transistor and photo diode.

In measuring the intensity of illumination or flux, the photo conductive sensor or photo transistor or light sensor module can be used (Fig 7).

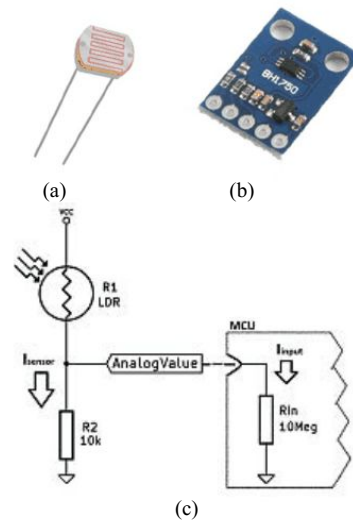

Fig. 7 Conductive photo sensor: (a) LDR sensor, (b) BHI750 sensor module, and (c) signal conditioning circuit from sensor to microcontroller unit (MCU)

IV.W IRELESS SENSOR NETWORK

Wireless sensor network is a wireless network consisting of spatial automation devices distributed using sensors to monitor collectively about physical or environmental conditions, such as temperature, sound, vibration, pressure, movement or pollutants in different locations. This network connects between sensor nodes, routers and sink nodes / gateways. Network configuration nodes are connected in an ad hoc manner (communicating directly to each other without network infrastructure such as routers or access points) and multi-hop (communication devices involving intermediate devices to forward packets of data from one node to another).

A sensor node consists of a node (devices for storage, computation and communication can be a microcontroller) and sensors (sensing physical phenomena such as temperature, light, sound, etc.) The protocol for communicating between node

sensors need light protocol not only can save energy (sensor node usually uses battery for energy source) but also have capability to send data in low loss. Those protocols can be Zigbee, MQTT and other protocol for IoT.

A. ZigBee

ZigBee is a specification for high-level communication networks protocol using digital radios in small-sized and low-power based on IEEE 802.15.4-2003 standards for low-level wireless personal networks (WPN), such as flash lights, home display (IHD) and other consumer electronic devices that use a short-range radio network with low-level transfer power data.

Technology that meets the specifications of ZigBee is low-cost, simple, and low-power device with easy capital, simple, requires very low power and low cost comparing to other WPANs (Fig. 8). ZigBee focuses on Radio Frequency (RF) applications that require low-level data, long battery life, and secure networks.

The ZigBee protocol is intended for use in applications requiring low data rates and power consumption which can then be used for industrial control, sensing, medical settlement data, fire alarms and intruders, building automation, Home automation, and so forth.

TCP/IP Protocol Stack	Z-Wave	ZigBee	6LoWPAN
Application: HTTP, RTP, FTP, etc.	Device & Command Classes	Application Profile(s)	HTTP
Transport: TCP, UDP, ICMP	Routing Layer	Network Services	UDP, ICMP
Network: IP	Transfer Layer	NWK Layer	IPv6 with 6LoWPAN
Data Link: Ethernet MAC	Proprietary MAC	IEEE802.15.4 MAC	IEEE802.15.4 MAC
Physical: Ethernet PHY	Proprietary PHY	IEEE802.15.4 PHY	IEEE802.15.4 PHY

Fig. 8 Comparison of Zigbee protocol with TCP / IP, Z-Wave and 6LoWPan protocols [18]

B. MQTT

Message Queue Telemetry Transport (MQTT) is a message protocol for M2M. The MQTT protocol runs on over TCP/IP stack and has a small data packet size with a low overhead minimum of 2 bytes so that the power consumption is small. Data usually are sent in binary-data, text even XML or JSON. This protocol was created by Andy Stanford - Clark from IBM and Arlen Nipper from Cirrus Link Solutions.

Working Principle MQTT (Fig. 9)

- The MQTT protocol uses publish-subscribe principle.
- Components (usually sensors) generating certain info and are called by publishers.
- Clients attempting to get particular topic registers on a particular topic, this process is called subscribe. Those clients are called by subscriber.
- Brokers guarantee subscriber get the desired info from the publisher.

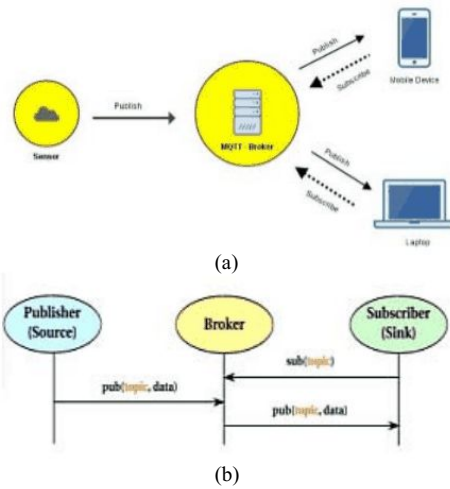

Fig. 9 MQTT Diagram (a) MQTT Protocol Architecture on WSN and (b) State Diagram of MQTT protocol [19]

V.M ETHODOLOGY OF ELECTRONIC ENERGY AUDIT

This electronic energy audit system consists of sensor nodes in WSN and information system that installed in web server. Overall this proposed electronic energy audit is showed in Fig 10. The some traditional energy processes of energy measurement and energy use analyze (Fig. 2) can changed with sensor node in WSN (green dashed-line in Fig. 10) and information system (red dashed-line in Fig 10) in web server respectively.

Data should be prepared to input for information system; e.g. energy use histories, floor area, electricity area and occupancy. This data are used for data reference in analyzing energy use profile of building. The measurement in traditional processed is done by technician; whereas this measurement of proposed process is done by sensor node in WSN. Sensor nodes are placed in main electrical panels (current measurement by current transformer sensors), air-conditioned rooms (temperature and humidity measurement) and other rooms office or class rooms (flux measurement). Measurement data from each sensor node is sent to the gateway host using the Zigbee protocol, then gateway forwards data to the server using the MQTT protocol in real time. These protocols are chosen because light weight, energy save, and not complicated. This real time monitoring should be done in enough period of time to determine trends in energy use within the building.

Previous process has entered into energy audit to collect about energy use profile in building. Other data are also required such as electricity bill history within a year, and the floor plan of each room and its electrical equipment, energy supply (genset or LPG). Energy audit information system is installed in server for doing analysis process to analyze energy-saving opportunities (ESO) and data plotting from each sensor in real time. Diagram of Electronic Energy Audit system are shown in Fig. 11.

V.I.C ONCLUSION

This paper describes the idea of electronic energy audit integrated with wireless sensor network using IoT concept. This proposed process of energy audit can replace technicians for measuring energy use of appliances (replaced by sensor node in WSN) and auditor for analyzing EUI and ESO (replaced by information system in server). Further this electronic energy audit can be synergized in the development of smart building.

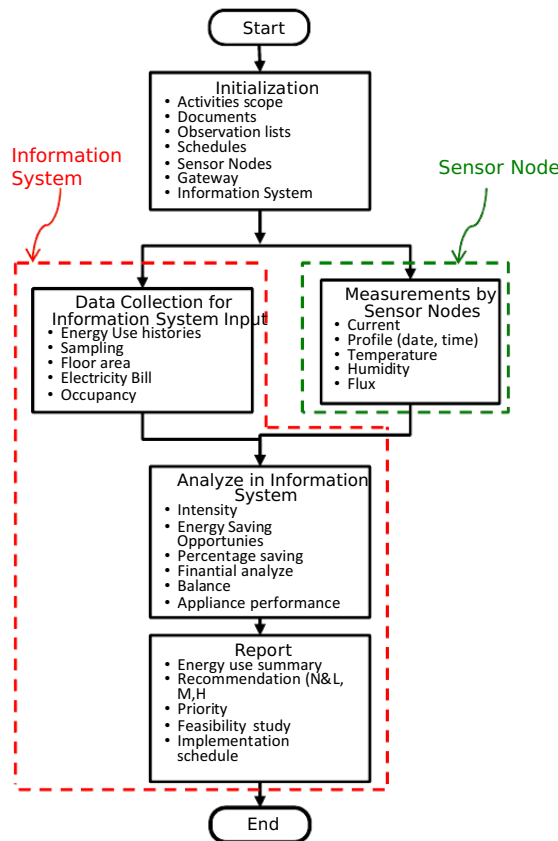

Fig. 10 Flow Diagram of Electronic Energy Audit Process

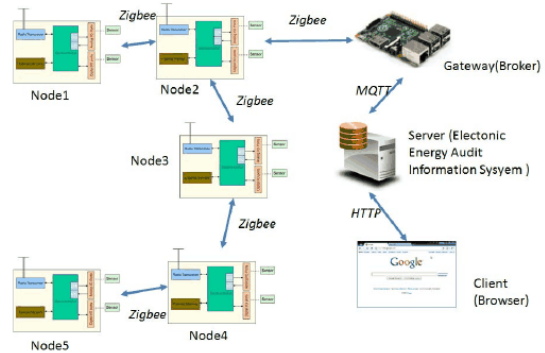

Fig. 11 Diagram of Electronic Energy Audit System integrated with Wireless Sensor System

REFERENCES

- [1]H. R. Hadiputra,(2007). **Audit Energi Pada Bangunan Gedung Rumah Sakit Dr . Karyadi Semarang** [Energy Audit in Building of Dr. Karyadi Hospital, Semarang). Semarang. Available: http://www.elektro.undip.ac.id/el_kpta/wp-content/uploads/2012/05/L2F004482_MKP.pdf. [Accessed: April 11, 2017].
- [2]A. Marzuki and D. A. N. Rusman, "Audit Energi pada Bangunan Gedung Direksi PT . Perkebunan Nusantara XIII (Persero)," *Vokasi*, vol. 8, no. 3, pp. 184–196, 2012.
- [3]M. P. T. Sulistyanto, D. A. Nugraha, N. Sari, N. Karima, and W. Asrori, "Implementasi IoT (Internet of Things) dalam pembelajaran di Universitas Kanjuruhan Malang [Internet of Things Implementation for Learning in Kanjuruhan University of Malang]" *SMARTICS Journal*, vol. 1, no. 1, pp. 20–23, 2015.
- [4]W. Herwanto et al., "Implementasi Wireless Sensor Network Untuk Monitoring Ruang Kelas Sebagai Bagian Dari Internet Of Things [Wireless Sensor Network Implementation for Class Room Monitoring as Part of Internet of Things]" *Tekno*, vol.22, no. 1, pp. 47–64, 2014.
- [5]Penyelenggaraan Usaha Jasa Konservasi Energi [Business Operation of Energy Conservation Services],Permen ESDM No. 1, 2016.
- [6]HumasUGM, "Konservasi Energi Dalam Penyediaan Energi Nasional," 2005. [Online]. Available: <http://ugm.ac.id/id/berita/1057-konservasi.energi.dalam.penyediaan.energi.nasional>. [Accessed: 05-Apr-2017].
- [7]Energytoday.com, "Penggunaan Listrik di Indonesia Masih Boros [Electricity Use in Indonesia Still Wasteful]," 2016. [Online]. Available: <http://energytoday.com/id/2016/05/penggunaan-listrik-di-indonesia-masih-boros/>. [Accessed: 05-Apr-2017]
- [8]Kompas, "Indonesia Terboros Dalam Memakai Listrik Di ASEAN [Indoesia is Wasteful Electricity Use Country in ASEAN] ," 2010. [Online]. Available: <http://www.alpensteel.com/article/131-225-pemadaman-listrik/1330-indonesia-terboros-dalam-memakai-listrik-di-asean>. [Accessed: 05-Apr-2017]
- [9]Prosedur Audit Energi Pada Bangunan Gedung [Audit Energy Procedur in Building], SNI 6196-2011, Jakarta, 2011.
- [10]K. Rahardian, "Intensitas Konsumsi Energi [Energy Use Intensity]," 2015. [Online]. Available: <http://www.bikasolusi.co.id/intensitas-konsumsi-energi> [Accessed: 24-Apr-2017].
- [11]Energy Audits, AS/NZS 3598, 2000.
- [12]W. Arismundar and H. Saito, *Penyegaran Udara [Air Conditioning]*. Jakarta: PT. Pradnya Paramita, 2004.
- [13]S. Schiavon, T. Hoyt, S. Schiavon, T. Hoyt, and A. Piccoli, "Web application for thermal comfort visualization and calculation according to

- ASHRAE Standard 55 Web application for thermal comfort visualization and calculation,” vol. 7, pp. 321–334, 2014.
- [14]Trafoinstrumentasi.com, “Prinsip kerja Trafo Arus atau Current Transformator [Current Tranformer Mechaism],” 2016. [Online]. Available: <https://trafoinstrumentasi.com/2016/06/14/prinsip-kerja-trafo-arus-atau-current-transformer/> [Accessed: 24-Apr-2017].
- [15]openenergymonitor.org, “CT sensors - Interfacing with an Arduino,” 2012. [Online]. Available: <https://openenergymonitor.org/forum-archive/node/156.html> . [Accessed: 24-Apr-2017].
- [16]D. Kho, “Pengertian Thermistor (NTC dan PTC) Beserta Karakteristiknya [Thermistor (NTC and PTC) Definition with Its Characteristics],” 2015. [Online]. Available: <http://teknikelektronika.com/pengertian-thermistor-ntc-ptc-karakteristik/> [Accessed: 24-Apr-2017].
- [17]A. Tripathy, S. Pramanik, J. Cho, J. Santhosh, N. Azuan, and A. Osman, “Role of Morphological Structure, Doping, and Coating of Different Materials in the Sensing Characteristics of Humidity Sensors,” *Sensors*, vol 14, pp. 16343–16422, 2014.
- [18]A. Joshi, “Internet of Things: Comparison of Protocols & Standards”, 2014. [Online]. Available: <https://www.slideshare.net/Techtsunami/cn-prt-iot-v1> [Accessed: 24-Apr-2017].
- [19]Junwatu, “Mengenal MQTT [MQTT Introduction]”, 2015. [Online]. Available : <https://jsioi.pw/mengenal-mqtt-998b6271f585> [Accessed: 24-Apr-2017].

 Similarity Similarity from a chosen source Possible character replacement Citation References