

TAILORING OF PROPERTIES THROUGH SQUEEZE CASTING TECHNIQUE

P.K.Biswas
National Metallurgical Laboratory
Jamshedpur 831007

INTRODUCTION

Squeeze casting is a single stage casting process for directly converting liquid metal into a fully shaped component by applying continued pressure in the solid-liquid range till solidification is complete. Fig.1 shows major steps of operation involved in squeeze casting namely:

- (a) Filling of mould with measured quantity of metal
- (b) Application of pressure and sustaining till completion of solidification
- (c) Ejection of casting

variation of squeeze casting is shown in Fig.2. In the extrusion variant the liquid metal is extruded backwards around the contour punch enabling a more complicated casting shape to be obtained. The indirect variant is essentially a vertical die casting arrangement features a controlled slow fill followed by high applied pressure. The possibility of combining casting and forging processes were initially examined in detail in Russia during late thirties principally by Plyatskii. In the west the process has been commercially exploited very recently and in India it is new.

2. ADVANTAGES OF SQUEEZE CASTING

- ° Components can be produced to net or near net shape
- ° High metallurgical integrity in components

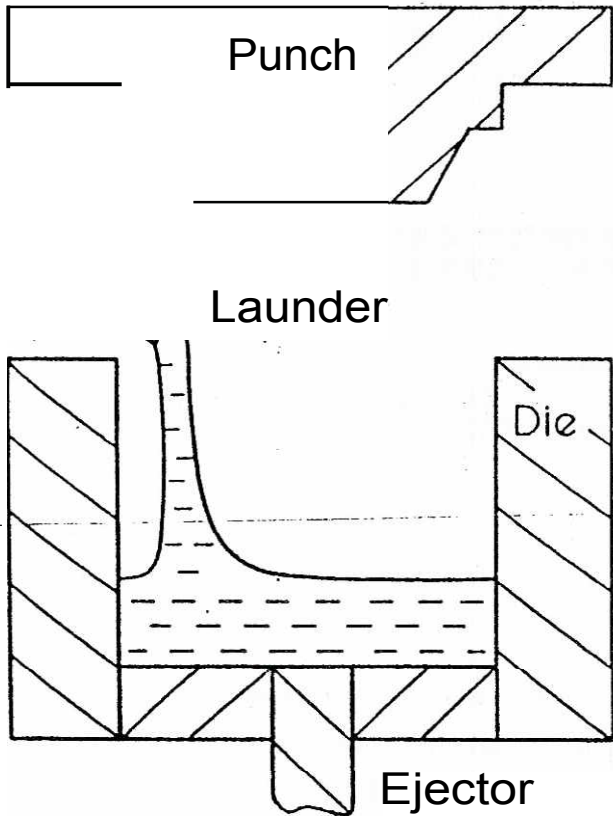

(a) MOLTEN METAL POURED INTO DIE

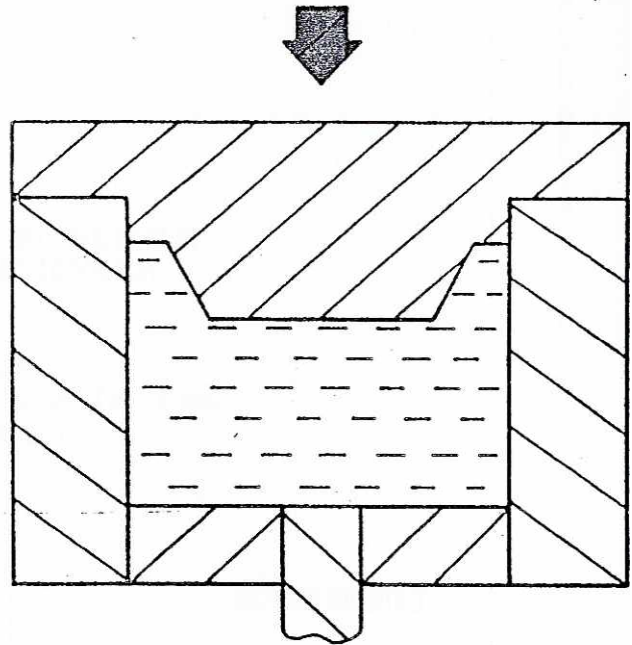

(c) PRESSURE APPLIED TO MOLTEN METAL

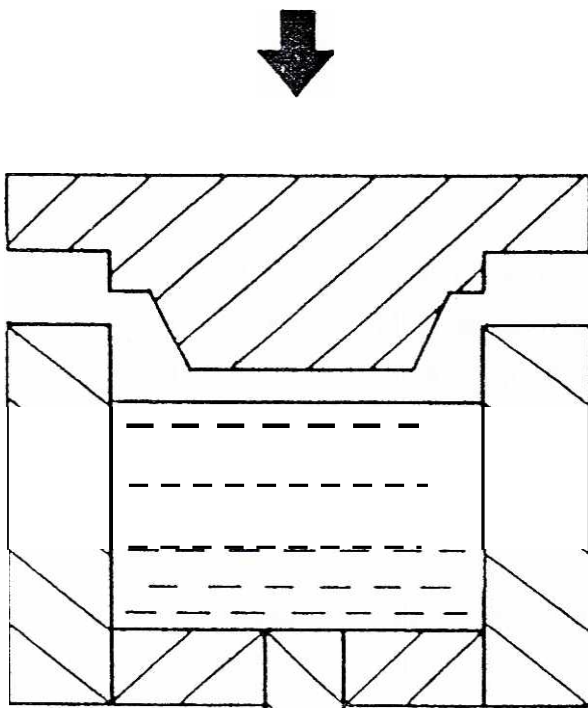

(b) PUNCH ACTIVATED

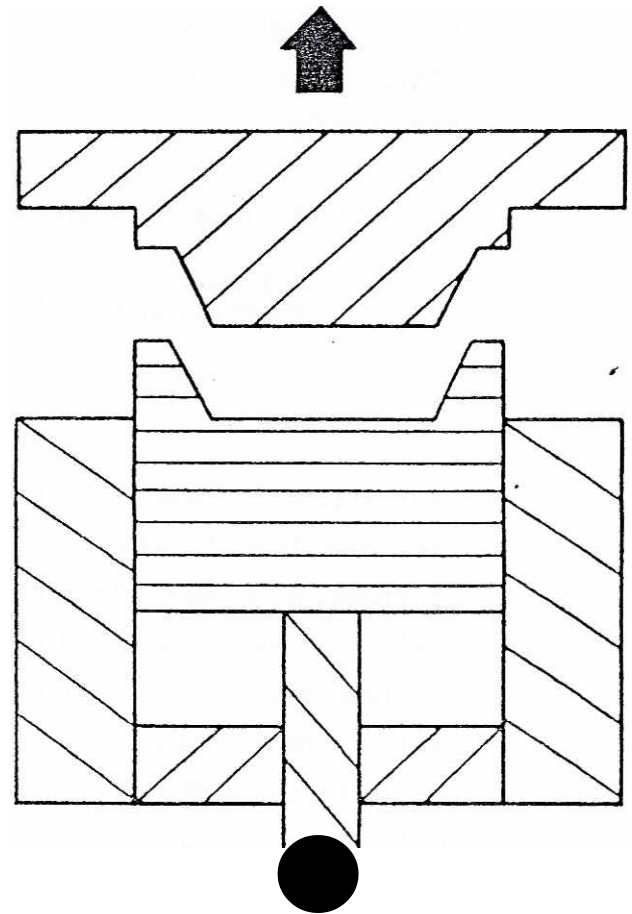

(d) CASTING EJECTED

FIG.1. STEPS IN PRODUCING SQUEEZE CASTING

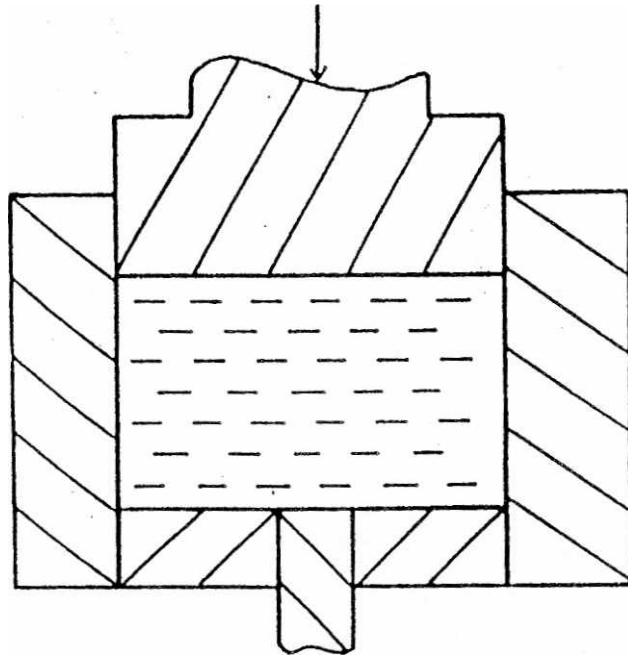

(a) SQUEEZE CASTING

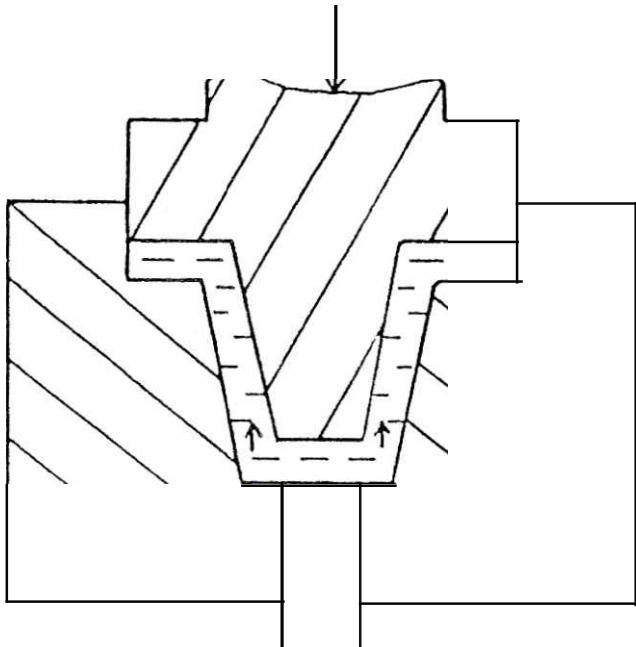

(b) EXTRUSION CASTING

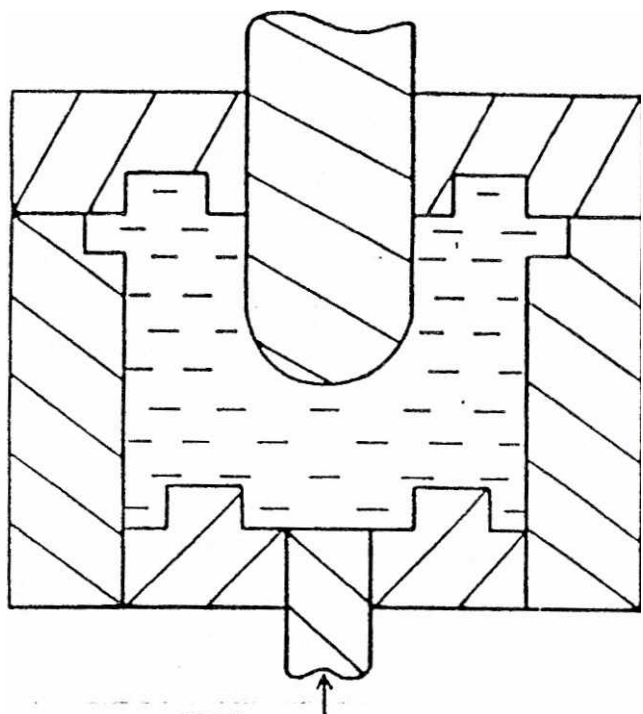

(c) INDIRECT PRESSURE SOLIDIFICATION
r,

FIG.2. SCHEMATIC REPRESENTATION OF SQUEEZE CASTING MODES

- o Gas and shrinkage free sand casting
- o Excellent surface finish and contour details
- o Low pressure requirements
- o Applicable to metal matrix composites

3. PRINCIPLES

The process takes advantage of Clausius-Clayperon's equation:

$$\frac{dT_m}{dp} = \frac{T_m (V_L - V_S)}{L},$$

where T_m is the melting temperature, L is the latent heat of fusion, V_L and V_S are specific volumes of liquid and solid phases respectively. It is evident from the above equation that application of pressure raises the melting point. Majority of metals show a rise of 2-6°C for every 98 N/mm² of external pressure applied⁽¹⁾. For magnesium alloys application of 100 MPa produces a rise of 6.5°C in melting temperature⁽²⁾. For aluminium and copper alloys at 18000 kg/cm², the corresponding rises are 110 and 90°C respectively⁽³⁾. Pressure application also distorts the phase diagram as can be seen in Mg-Al and Al-Si system in Fig.3. Eutectic is shifted to the right in the direction of higher concentration of the component whose melting point is least affected. This shift in eutectic causes undercooling and grain refining action at comparatively higher temperature. Further, since the metal to die contact is intimate due to pressure application, heat transfer rate will be very high resulting in smaller dendrite arm spacing. Heat transfer coefficient h for squeeze casting is as high as 0.2-3.3 Cal/cm² sec.°C in contrast to values of 0.02-0.06 Cal/cm² sec.°C in permanent mould casting⁽⁴⁾. This gives improved mechanical properties in the casting.

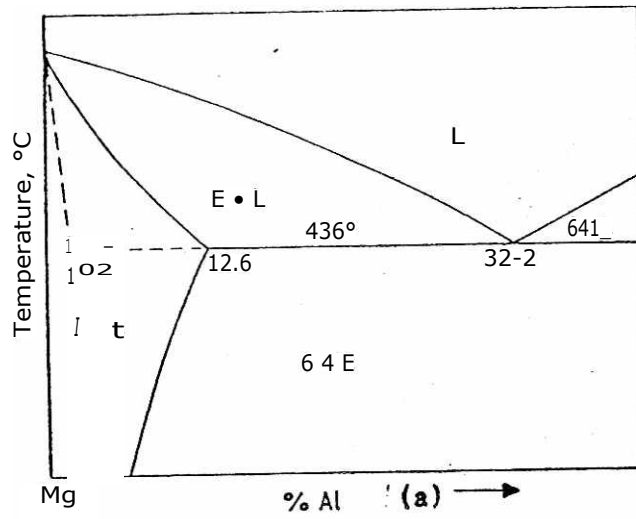

Fig. 3a.

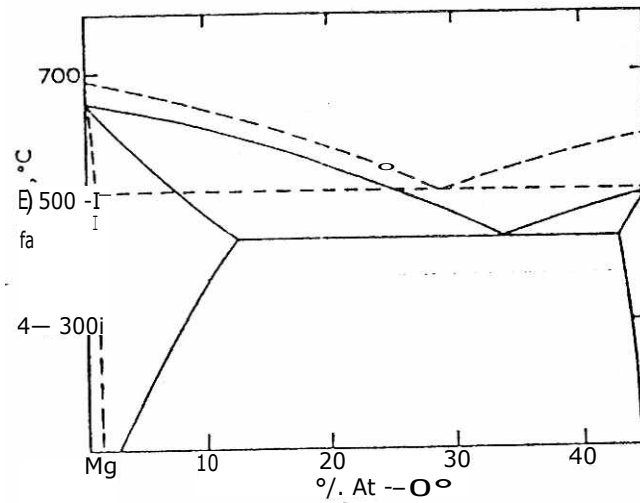

Fig. 3b.

(b)

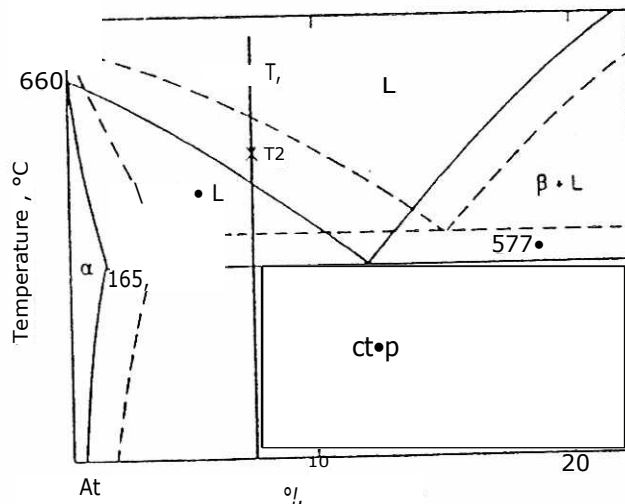

Fig. 3c.

(c):

FIG.3.(a) EFFECT OF RAPID SOLIDIFICATION (100 C/MIN) ON Mg-Al EQUILIBRIUM DIAGRAM INDICATED BY DASHED LINE. (b) RAPID COOLING COMBINED WITH PRESSURE APPLICATION CAUSES DEVIATION (DASHED LINE) FROM EQUILIBRIUM CONDITION (SOLID LINE) (c) RAPID COOLING COMBINED WITH PRESSURE APPLICATION CAUSES DEVIATION IN Al-Si EQUILIBRIUM DIAGRAM. -- PRESSURE 1 KILOBAR

4. **COMPARATIVE ASSMIENT OF SQUEEZE CASTDE WITH OTHER DIE CASTING AND FORGING PROCESSES**

Each alternate method has distinct capabilities and related cost which determine the specific area of application. Fig.4 portrays the fabrication of a bowl shaped component by alternate rigid die, machine forming techniques. Tables I-VII give the effect of forming process on microstructure and mechanical properties^(3,4). Fig.5 compares microstructures of a leaded tin bronze . developed under different casting processes ⁽⁴⁾. The refinement of microstructure in squeeze casting product is obvious.

4.1 **Comparative Advantages of Squeeze Casting Process**

Components from various alloys can be produced (both forging and casting alloys). Low plasticity, brittle alloys and pure metals can be processed since the material is under hydrostatic compression.

Power required is 6-8 times lower than that for hot forging for a given component.

Possible to produce big/thin sections and complex ribs with large linear dimensions and thin walls starting from 2 mm.

Misalignment is not encountered due to incorrect positioning of the wrkpiece.

Mechanical wear of die is less compared to hot forging die.

Cycle time of the process is substantially less.

Constant dimensional accuracy is maintained.

4.2 **Comparative Advantages of Squeeze Casting Over Die Casting**

Travel distance of molten metal to die is less as co7pared to die casting which enables to maintain the fluidity and fills the mould at lower pressure and speed. This improves mould life.

Table 3. Comparative properties of commercial.. Cu-base alloys (Ref.1)

Alloy	Form	Tensile strength (N/mm ²)	Yield strength (N/mm ²)	Elongation (%)	Hardness (HV)
Cu-30Zn	a) Cast	200	100	10	100
	b) Sand casting	150	75	15	75
Cu-40Zn	a) Cast	250	125	10	125
	b) Sand casting	180	90	12	90
Cu-50Zn	a) Cast	300	150	10	150
	b) Sand casting	220	110	12	110

Table III: Comparative properties of common aqueous systems.

	T.S. (MN/m ²)	σ_{max} (%)	Elongation (%)
347 SS (annealed)	1000	~10	~10
304 SS (annealed)	~500	~10	~10
304 SS (cold treated)	~1000	~10	~10
Aluminum (annealed)	~100	~10	~10
Aluminum (cold treated)	~100	~10	~10
Polystyrene (annealed)	~10	~10	~10
Polystyrene (cold treated)	~10	~10	~10
PMMA (annealed)	~10	~10	~10
PMMA (cold treated)	~10	~10	~10
PC (annealed)	~10	~10	~10
PC (cold treated)	~10	~10	~10
PS (annealed)	~10	~10	~10
PS (cold treated)	~10	~10	~10
PE (annealed)	~10	~10	~10
PE (cold treated)	~10	~10	~10
PP (annealed)	~10	~10	~10
PP (cold treated)	~10	~10	~10
PC (annealed)	~10	~10	~10
PC (cold treated)	~10	~10	~10
PS (annealed)	~10	~10	~10
PS (cold treated)	~10	~10	~10
PE (annealed)	~10	~10	~10
PE (cold treated)	~10	~10	~10
PP (annealed)	~10	~10	~10
PP (cold treated)	~10	~10	~10

Comparative properties of commercial Al-base alloys *in* *the*

	COMWLNT PVODGSS	T.S. (MN/m ²)	Y.S. (Mn/m ²)	Elongation (%)
1- A 1... S	0 1 a' a)	0 1 4 J	0 1 4 J	0 1 4 J
2- B 1... L	0 1 4 J	0 1 4 J	0 1 4 J	0 1 4 J
3- C 1... V	0 1 4 J	0 1 4 J	0 1 4 J	0 1 4 J
4- D 1... Y	0 1 4 J	0 1 4 J	0 1 4 J	0 1 4 J
5- E 1... W	0 1 4 J	0 1 4 J	0 1 4 J	0 1 4 J
6- F 1... X	0 1 4 J	0 1 4 J	0 1 4 J	0 1 4 J
7- G 1... Z	0 1 4 J	0 1 4 J	0 1 4 J	0 1 4 J
8- H 1... AA	0 1 4 J	0 1 4 J	0 1 4 J	0 1 4 J
9- I 1... AB	0 1 4 J	0 1 4 J	0 1 4 J	0 1 4 J
10- J 1... AC	0 1 4 J	0 1 4 J	0 1 4 J	0 1 4 J
11- K 1... AD	0 1 4 J	0 1 4 J	0 1 4 J	0 1 4 J
12- L 1... AE	0 1 4 J	0 1 4 J	0 1 4 J	0 1 4 J
13- M 1... AF	0 1 4 J	0 1 4 J	0 1 4 J	0 1 4 J
14- N 1... AG	0 1 4 J	0 1 4 J	0 1 4 J	0 1 4 J
15- O 1... AH	0 1 4 J	0 1 4 J	0 1 4 J	0 1 4 J
16- P 1... AI	0 1 4 J	0 1 4 J	0 1 4 J	0 1 4 J
17- Q 1... AJ	0 1 4 J	0 1 4 J	0 1 4 J	0 1 4 J
18- R 1... AK	0 1 4 J	0 1 4 J	0 1 4 J	0 1 4 J
19- S 1... AL	0 1 4 J	0 1 4 J	0 1 4 J	0 1 4 J
20- T 1... AM	0 1 4 J	0 1 4 J	0 1 4 J	0 1 4 J
21- U 1... AN	0 1 4 J	0 1 4 J	0 1 4 J	0 1 4 J
22- V 1... AO	0 1 4 J	0 1 4 J	0 1 4 J	0 1 4 J
23- W 1... AP	0 1 4 J	0 1 4 J	0 1 4 J	0 1 4 J
24- X 1... AQ	0 1 4 J	0 1 4 J	0 1 4 J	0 1 4 J
25- Y 1... AR	0 1 4 J	0 1 4 J	0 1 4 J	0 1 4 J
26- Z 1... AS	0 1 4 J	0 1 4 J	0 1 4 J	0 1 4 J
27- AA 1... AT	0 1 4 J	0 1 4 J	0 1 4 J	0 1 4 J
28- AB 1... AU	0 1 4 J	0 1 4 J	0 1 4 J	0 1 4 J
29- AC 1... AV	0 1 4 J	0 1 4 J	0 1 4 J	0 1 4 J
30- AD 1... AW	0 1 4 J	0 1 4 J	0 1 4 J	0 1 4 J
31- AE 1... AX	0 1 4 J	0 1 4 J	0 1 4 J	0 1 4 J
32- AF 1... AY	0 1 4 J	0 1 4 J	0 1 4 J	0 1 4 J
33- AG 1... AZ	0 1 4 J	0 1 4 J	0 1 4 J	0 1 4 J
34- AH 1... BA	0 1 4 J	0 1 4 J	0 1 4 J	0 1 4 J
35- AI 1... BB	0 1 4 J	0 1 4 J	0 1 4 J	0 1 4 J
36- AJ 1... BC	0 1 4 J	0 1 4 J	0 1 4 J	0 1 4 J
37- AK 1... BD	0 1 4 J	0 1 4 J	0 1 4 J	0 1 4 J
38- AL 1... BE	0 1 4 J	0 1 4 J	0 1 4 J	0 1 4 J
39- AM 1... BF	0 1 4 J	0 1 4 J	0 1 4 J	0 1 4 J
40- AN 1... BG	0 1 4 J	0 1 4 J	0 1 4 J	0 1 4 J
41- AO 1... BH	0 1 4 J	0 1 4 J	0 1 4 J	0 1 4 J
42- AP 1... BI	0 1 4 J	0 1 4 J	0 1 4 J	0 1 4 J
43- AQ 1... BJ	0 1 4 J	0 1 4 J	0 1 4 J	0 1 4 J
44- AR 1... BK	0 1 4 J	0 1 4 J	0 1 4 J	0 1 4 J
45- AS 1... BL	0 1 4 J	0 1 4 J	0 1 4 J	0 1 4 J
46- AT 1... BM	0 1 4 J	0 1 4 J	0 1 4 J	0 1 4 J
47- AU 1... BN	0 1 4 J	0 1 4 J	0 1 4 J	0 1 4 J
48- AV 1... BO	0 1 4 J	0 1 4 J	0 1 4 J	0 1 4 J
49- AW 1... BP	0 1 4 J	0 1 4 J	0 1 4 J	0 1 4 J
50- AX 1... BQ	0 1 4 J	0 1 4 J	0 1 4 J	0 1 4 J
51- AY 1... BR	0 1 4 J	0 1 4 J	0 1 4 J	0 1 4 J
52- AZ 1... BS	0 1 4 J	0 1 4 J	0 1 4 J	0 1 4 J
53- BA 1... BT	0 1 4 J	0 1 4 J	0 1 4 J	0 1 4 J
54- BB 1... BU	0 1 4 J	0 1 4 J	0 1 4 J	0 1 4 J
55- BC 1... BV	0 1 4 J	0 1 4 J	0 1 4 J	0 1 4 J
56- BD 1... BW	0 1 4 J	0 1 4 J	0 1 4 J	0 1 4 J
57- BE 1... BX	0 1 4 J	0 1 4 J	0 1 4 J	0 1 4 J
58- BF 1... BY	0 1 4 J	0 1 4 J	0 1 4 J	0 1 4 J
59- BG 1... BZ	0 1 4 J	0 1 4 J	0 1 4 J	0 1 4 J
60- BH 1... CA	0 1 4 J	0 1 4 J	0 1 4 J	0 1 4 J
61- BI 1... CB	0 1 4 J	0 1 4 J	0 1 4 J	0 1 4 J
62- BJ 1... CC	0 1 4 J	0 1 4 J	0 1 4 J	0 1 4 J
63- BK 1... CD	0 1 4 J	0 1 4 J	0 1 4 J	0 1 4 J
64- BL 1... CE	0 1 4 J	0 1 4 J	0 1 4 J	0 1 4 J
65- BM 1... CF	0 1 4 J	0 1 4 J	0 1 4 J	0 1 4 J
66- BN 1... CG	0 1 4 J	0 1 4 J	0 1 4 J	0 1 4 J
67- BO 1... CH	0 1 4 J	0 1 4 J	0 1 4 J	0 1 4 J
68- BP 1... CI	0 1 4 J	0 1 4 J	0 1 4 J	0 1 4 J
69- BQ 1... CJ	0 1 4 J	0 1 4 J	0 1 4 J	0 1 4 J
70- BR 1... CK	0 1 4 J	0 1 4 J	0 1 4 J	0 1 4 J
71- BS 1... CL	0 1 4 J	0 1 4 J	0 1 4 J	0 1 4 J
72- BT 1... CM	0 1 4 J	0 1 4 J	0 1 4 J	0 1 4 J
73- BU 1... CN	0 1 4 J	0 1 4 J	0 1 4 J	0 1 4 J
74- BV 1... CO	0 1 4 J	0 1 4 J	0 1 4 J	0 1 4 J
75- BW 1... CP	0 1 4 J	0 1 4 J	0 1 4 J	0 1 4 J
76- BX 1... CQ	0 1 4 J	0 1 4 J	0 1 4 J	0 1 4 J
77- BY 1... CR	0 1 4 J	0 1 4 J	0 1 4 J	0 1 4 J
78- BZ 1... CS	0 1 4 J	0 1 4 J	0 1 4 J	0 1 4 J
79- CA 1... CT	0 1 4 J	0 1 4 J	0 1 4 J	0 1 4 J
80- CB 1... CU	0 1 4 J	0 1 4 J	0 1 4 J	0 1 4 J
81- CC 1... CV	0 1 4 J	0 1 4 J	0 1 4 J	0 1 4 J
82- CD 1... CW	0 1 4 J	0 1 4 J	0 1 4 J	0 1 4 J
83- CE 1... CX	0 1 4 J	0 1 4 J	0 1 4 J	0 1 4 J
84- CF 1... CY	0 1 4 J	0 1 4 J	0 1 4 J	0 1 4 J
85- CG 1... CZ	0 1 4 J	0 1 4 J	0 1 4 J	0 1 4 J
86- CH 1... DA	0 1 4 J	0 1 4 J	0 1 4 J	0 1 4 J
87- CI 1... DB	0 1 4 J	0 1 4 J	0 1 4 J	0 1 4 J
88- CJ 1... DC	0 1 4 J	0 1 4 J	0 1 4 J	0 1 4 J
89- CK 1... DD	0 1 4 J	0 1 4 J	0 1 4 J	0 1 4 J
90- CL 1... DE	0 1 4 J	0 1 4 J	0 1 4 J	0 1 4 J
91- CM 1... DF	0 1 4 J	0 1 4 J	0 1 4 J	0 1 4 J
92- CN 1... DG	0 1 4 J	0 1 4 J	0 1 4 J	0 1 4 J
93- CO 1... DH	0 1 4 J	0 1 4 J	0 1 4 J	0 1 4 J
94- CP 1... DI	0 1 4 J	0 1 4 J	0 1 4 J	0 1 4 J
95- CQ 1... DJ	0 1 4 J	0 1 4 J	0 1 4 J	0 1 4 J
96- CR 1... DK	0 1 4 J	0 1 4 J	0 1 4 J	0 1 4 J
97- CS 1... DL	0 1 4 J	0 1 4 J	0 1 4 J	0 1 4 J
98- CT 1... DM	0 1 4 J	0 1 4 J	0 1 4 J	0 1 4 J
99- CU 1... DN	0 1 4 J	0 1 4 J	0 1 4 J	0 1 4 J
100- CV 1... DO	0 1 4 J	0 1 4 J	0 1 4 J	0 1 4 J

Table VI: Comparative properties of CDA 925* leaded tin bronze
(Ref 04)

Test	Sand cast	Squeeze cast
<u>Tension test</u>		
L _{rrs} (MN/2)	310.8	387.8
YS (nN/m ²)	184.8	249.2
Elongation (7)	16.5	19.2
Hardness R _E	84.0	98.0
<u>Wear Test</u>		
Initial static coefficient of friction	0.158	0.192
Final static coefficient of friction	0.124	0.149
Final coefficient of friction	0.200	0.142

* CDA = 11% Sn

Table VII:

Squeeze cast		Gravity permanent mould cast	
<p>Maxim. stress (MN/m²) x 10³</p> <p>04 3 T-4 C*4 C^y CO</p> <p>T-4 01 C^x CX ON T-4</p> <p>CO N-4 L</p> <p>04 01 LC ty)</p>	<p>Maxim. stress (MN/m²)</p> <p>71</p> <p>0</p>	<p>Maxim. stress (MN/m²)</p> <p>31</p> <p>0</p>	<p>Maxim. stress (MN/m²)</p> <p>31</p> <p>0</p>
<p>Failure</p> <p>Runout</p>	<p>Failure</p> <p>Runout</p>	<p>Failure</p> <p>Runout</p>	<p>Failure</p> <p>Runout</p>

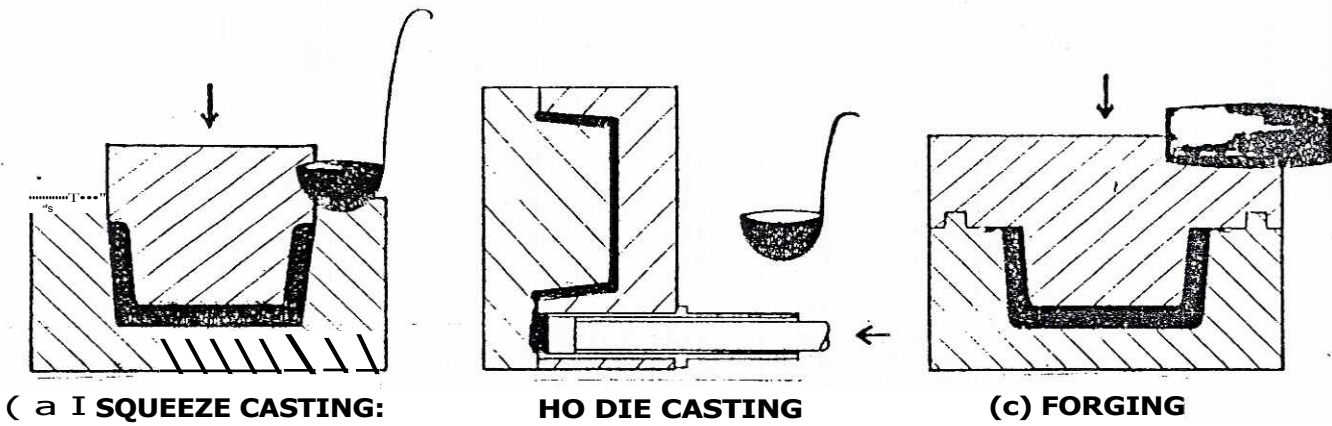
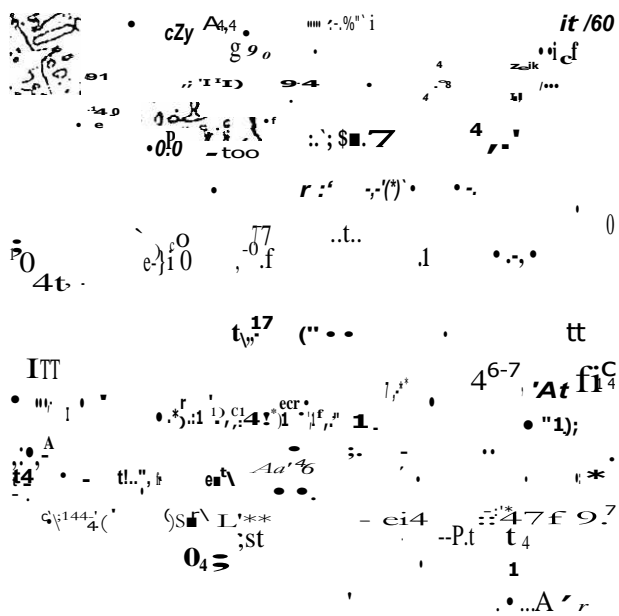
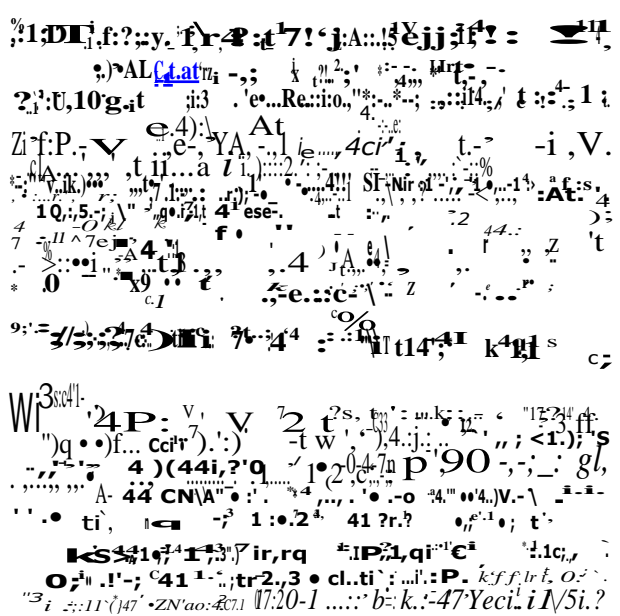

FIG.4. SCHEMATICS OF COMPONENT FABRICATION BY ALTERNATE PROCESSES



(a) SAND CAST



(b) PERMANENT MOLD CAST



(c) CONTINUOUS-CAST

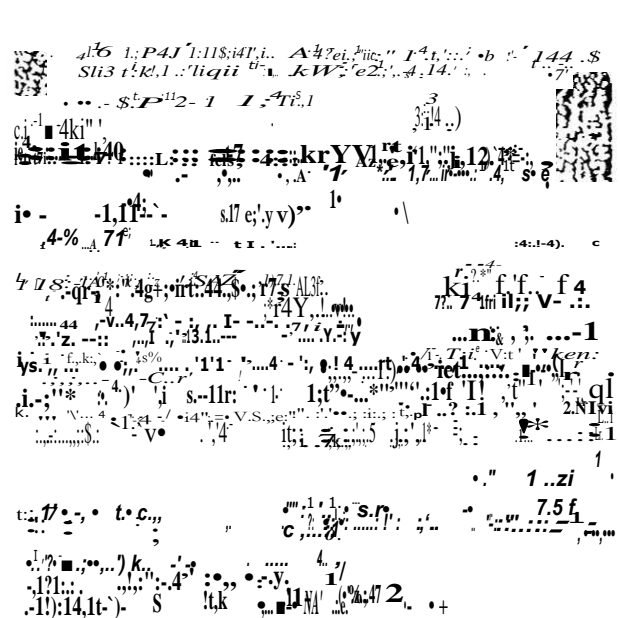

(d) SQUEEZE-CAST

FIG.6. COMPARATIVE MICROSTRUCTURES OF LEADED TIN BRONZE CDA 925 (X 50)

Air is not trapped in squeeze casting when melt is poured in open mould displacing a volume of air equal to the total volume of poured metal. Comparatively less movement of metal is required to fill the mould cavity.

- * Erosion of metal stream damage the die wall and the quality of casting in die casting. This is absent in squeeze casting.

There is no metal loss due to gating and risering.

5. ——— CASTING PROCESS CAPABILITIES

A wide range of non-ferrous alloys like Al, Mg, Zn and Cu base alloys can be easily processed and ferrous and super alloys are being tried.

Weight of squeeze cast component can range upto 20 kg.

Capable to thin section components down to 0.3 mm.

Production rate upto 60 casting per hour.

Capability to reproduce contour details.

Excellent dimensional accuracy.

Excellent surface finish equivalent to achievable in pressure die casting, 0.4-3.2 μm .

A comparison of various process capabilities⁽⁵⁾ is given in Table VIII.

6. SQUEEZE CASTING PROCESS PARAMETERS

6.1 Melt Quality and Quantity

The melt should be clean, free from oxides and preferably low in gas content. Non-turbulent melting and transfer procedure are desirable. To ensure consistency in operation and specially dimensional accuracy metal metering is essential.

TABLE.VIII.COMPARISON OF

Casting Process.	Alloy Range	Weight Range kg (lb)	Economical Quantity	Thin Section Capability mm (in)	Cast Hole Dimensions mm (in)	Surface Finish gm (gin)	Dimensional Accuracy mm (in)
Investment Casting	Aluminum	0.1 - 10	0.001 - 0.01	A	0.1 - 0.5	0.1 - 0.5	±0.01 - 0.05
Die Casting	Aluminum	0.1 - 10	0.001 - 0.01	A	0.1 - 0.5	0.1 - 0.5	±0.01 - 0.05
Shell Molding	Aluminum	0.1 - 10	0.001 - 0.01	A	0.1 - 0.5	0.1 - 0.5	±0.01 - 0.05
Lost Foam Casting	Aluminum	0.1 - 10	0.001 - 0.01	A	0.1 - 0.5	0.1 - 0.5	±0.01 - 0.05
Low Pressure Die Casting	Aluminum	0.1 - 10	0.001 - 0.01	A	0.1 - 0.5	0.1 - 0.5	±0.01 - 0.05
Hot Chamber Die Casting	Aluminum	0.1 - 10	0.001 - 0.01	A	0.1 - 0.5	0.1 - 0.5	±0.01 - 0.05
Centrifugal Casting	Aluminum	0.1 - 10	0.001 - 0.01	A	0.1 - 0.5	0.1 - 0.5	±0.01 - 0.05
Sand Casting	Aluminum	0.1 - 10	0.001 - 0.01	A	0.1 - 0.5	0.1 - 0.5	±0.01 - 0.05
Investment Casting	Steel	0.1 - 10	0.001 - 0.01	A	0.1 - 0.5	0.1 - 0.5	±0.01 - 0.05
Die Casting	Steel	0.1 - 10	0.001 - 0.01	A	0.1 - 0.5	0.1 - 0.5	±0.01 - 0.05
Shell Molding	Steel	0.1 - 10	0.001 - 0.01	A	0.1 - 0.5	0.1 - 0.5	±0.01 - 0.05
Lost Foam Casting	Steel	0.1 - 10	0.001 - 0.01	A	0.1 - 0.5	0.1 - 0.5	±0.01 - 0.05
Low Pressure Die Casting	Steel	0.1 - 10	0.001 - 0.01	A	0.1 - 0.5	0.1 - 0.5	±0.01 - 0.05
Hot Chamber Die Casting	Steel	0.1 - 10	0.001 - 0.01	A	0.1 - 0.5	0.1 - 0.5	±0.01 - 0.05
Centrifugal Casting	Steel	0.1 - 10	0.001 - 0.01	A	0.1 - 0.5	0.1 - 0.5	±0.01 - 0.05
Sand Casting	Steel	0.1 - 10	0.001 - 0.01	A	0.1 - 0.5	0.1 - 0.5	±0.01 - 0.05

Continued on next page

6.2 Pouring Temperature

This has direct influence on casting quality and die life. Low pouring temperature gives rise to cold laps and premature solidification. High temperature produces flashing through vents and clearance, porosity in the thick section casting and adversely affects the die life. Pouring temperatures will have to be carefully chosen depending upon the alloy system. Typically 6-55°C super heat in the liquid state is to be considered. In general short freezing range alloys require high pouring temperature. For Cu base alloys and steels superheat of the order of 30-150°C is required as they solidify rapidly immediately after making contact with the die.

6.3 Die Temperature

200-300°C is normally recommended for the dies for the production of squeeze cast Al base alloys[5] and a temperature of 15-20°C below the die temperature for the punch. For ferrous alloys the recommended die temperature is slightly above 400°C.

6.4 Applied Pressure

This depends upon the alloy chemistry, casting geometry and requires level of mechanical properties. For most alloys optimum pressure of 30-140 MPa pressure applied continuously is found to be giving excellent results. Fig.6 shows a typical relationship between applied pressure and mechanical properties for Al-12 Si (LM6) alloy. This, however, needs to be optimised for each system.

6.5 Pressure Application Time

This is an important factor, a period of 30-120 s are found to be sufficient for the process. Maintaining pressure after solidification only increases the cycle time.

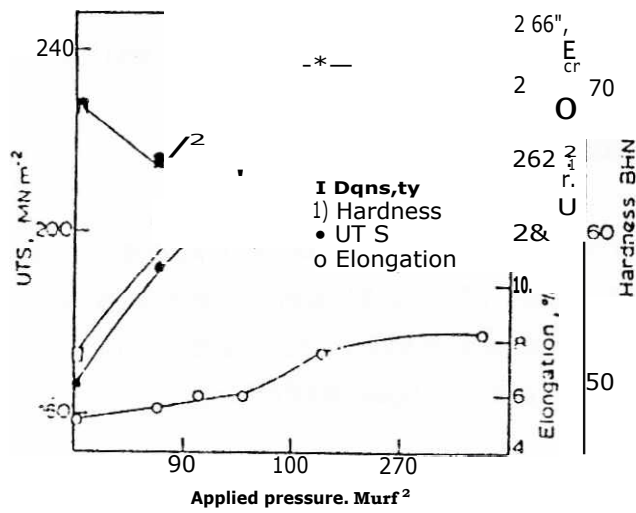

FIG.6. EFFECT OF APPLIED PRESSURE ON TENSILE STRENGTH, ELONGATION, HARDNESS AND DENSITY OF ALLOY LW:3, DIE TEMPERATURE 200°C

6.6 Temperature for Application of Pressure

Pressure should be applied immediately within few seconds after pouring the liquid metal for small casting. A time lag may be allowed in large castings upto one minute.

6.7 Press Speed

A high velocity punch contact will give adverse effect like dilation of die parts and splash at parting joints. For most practical purposes premature solidification punch impact speed should be 0.5 m/s.

6.8 Die Coating and Lubricant

The choice of lubricant and coating will depend upon the die material and alloy composition. **Colloidal** graphite with water base is **normally sprayed** on to the die and punch during each cycle. A ceramic type agent which is a mixture of alumina powder and binder in aqueous medium is found to be useful for squeeze casting of steel.

6.9 Die Material and Configuration

This depends on the alloy chemistry. Ideally the die should not react with the molten metal and the die should be able to withstand the service temperature and pressure. For Al alloys and **majority of** other non-ferrous **alloys H-13, Cr-Mo hot** worked die steel is used, which have a combination of moderate high temperature strength and adequate wear and thermal and fatigue resistance. For more severe conditions encountered in molten material highly alloyed with W and Mo are used as die material.

Partitioning of the die avoids thermal fatigue. To eliminate trapped air, the venting dimension must be less than 0.2 mm to avoid

metal extrusion and excessive flash. Corner radii on male tooling details are usually of the order of at least 2 mm for non-ferrous material and 3 mm for ferrous alloys. To facilitate casting ejection, external die wall draft angle should be of the Order of 0.5° , this is increased to $1-2^\circ$ on the punch surface and die details around which the casting tends to contract after solidification. Correct use of draft angle can help reduce the pressure needed to eliminate porosity. The clearance between the punch and female die is vital for correct pressure application. If the gap is large, problems of excessive flash associated with die wear occur. Also die wear occurs if the clearance is less resulting in friction and requirement of higher pressure to overcome the friction. The clearance dimensions are to be determined by the heat capacity of the die, die assembly, casting cycle and tooling temperature. The recommended clearance at room temperature is 0.15 mm. During production this dimension approaches zero as a result of thermal expansion and elastic deformation of the punch.

7. LIMITATIONS OF SQUEEZE CASTING

- * The capital cost is high as compared to die casting but lower than forging.
- * Die life is lower than the conventional die casting dies.
- * Complexity of shapes is limited.
- * Metal metering system has to be very accurate.

8. APPLICATIONS OF SQUEEZE CASTING

Squeeze casting process can be successfully employed for the production of automobile pistons, cylinders, wheels, clutch housings, engine blocks, connecting rods, hubs, brake drums, domestic cook ware etc. Fig.7 shows a range of squeeze cast products.

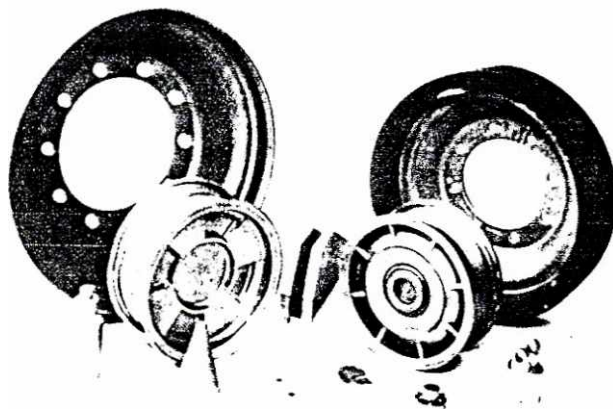
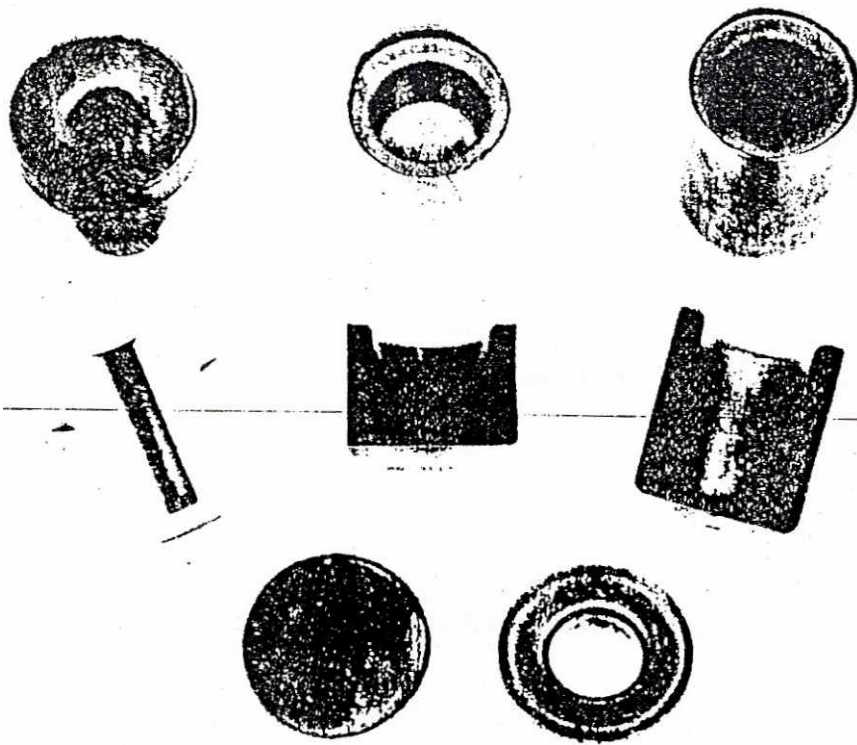

(b)

F10.7. PHOTOGRAPHS OF SQUEEZE CAST PRODUCTS
(a) BRASS AND BRONZE (b) ALUMINIUM

ACKNOWLEDGMENT

The author wishes to thank the Director, National Metallurgical Laboratory, Jamshedpur for permission to present the paper and to Dr. C.S.Sivaramakrishnan for constant encouragement and valuable discussions while preparing this paper.

REFERENCES

1. J.R.Franklin and A.A.Das, "Squeeze Casting - a review of the status", The British Foundryman, Vol.77, Part 3, April (1984) pp. 150-158.
2. G.A.Chadwick, "Squeeze casting of magnesium alloys and magnesium based metal matrix composites", Magnesium Technology, Proceedings of London Conference, November (1986), The Institute of Metals, pp.75-82.
3. V.M.Plyatskii, Extrusion Casting, New York Primary Sources (1965).
4. P.J.Mikelonis, Foundry Technology Source Book, American Foundrymen's Society (1982).
5. A.J.Clegg, Precision Casting Processes, Pergamon Press (1991).