

Process Control in Flotation Plants

M. R. JAKHU
Hindustan Zinc Limited, Udaipur

ABSTRACT

The processing of ores often entails use of unit operations such as grinding and flotation. Typical production requirements in mineral processing plants include the maximisation of throughput, maintenance of desired product quality and reduction of operating costs. For optimising plant performance, redesigning a process route is often impractical and the problem is best addressed through on-line optimisation which involves controlling key process parameters to achieve the desired production requirements. Process control, thus, plays a key role in on-line optimisation. However, given the number of constraints/variables and targets to be maintained simultaneously in a typical operation such as grinding or flotation, optimal performance can almost never be ensured through manual control. Automatic control is then the answer.

There are several level of abstraction in automatic control. This paper describes various on-line analysis system and automatic control systems available for various unit operations. Some of the process control systems adopted in HZL beneficiation plants to optimise the concentrator returns and more development efforts in pipeline to acquire model-based expert control systems to quest the thirst for modernisation by HZL are described in this paper.

Key Words : Flotation plants, Process control, On-line analyser, Grinding circuit, Benefits from process control system.

INTRODUCTION

Flotation is the most comprehensive and versatile mineral processing operation. Main areas where development efforts in full swing are equipment, reagents and process control. There are numerous variables in a flotation process out of which some are controllable and

others are beyond the control of operator. Variables like feed grade, fineness of crystallisation, degree of oxidation and quality of associated gangue are some of the variables which are beyond control. The other group which can be called disturbance and controllable variables are reagent addition rate and addition points, pulp level, air addition, collection point of concentrate, pulp densities, intermediate flow rates, etc. The third group can be within the scope for control, but once decided, cannot be varied like type of machines used for grinding, flotation cells etc. The fourth group is performance variables like desired grade of end products, recoveries, etc. The controllable variables need to be monitored and controlled in a proper manner to achieve optimum results.

Benefits of continuous analysis of process streams in a mineral processing plant lead to the development of device for X-ray fluorescence (XRF) analysis of flowing slurry stream in early 1960's. Two practical methods of "On-line" analysis namely, Centralised X-ray and In-stream probe system are finding wide application. The on-line pH sensors are widely used in process control.

Some types of devices are now available for on-line measurement of particle size based on the principle of ultrasound absorption or laser beam scattering. With proper control of particle size in the required size range in cyclone overflow product, down stream flotation operation becomes easy and efficient. Particle size monitors and automatic grinding circuit control systems are available for this purpose.

HZL has followed the track and new developments in the field are being adopted depending upon their suitability for our operations. Various process control systems available and adopted in HZL plants are described subsequently.

OBJECTIVES OF PROCESS CONTROL

The broad objectives of process control in general can be stated as follows :

"To maintain the process at the desired operating point specified by plant personnel, and to take appropriate action to reduce the effects of all disturbances that tend to drive the process away from the specified operating point."

A desired operating point is usually the combination of number of setpoints (SP) and constraints, that specify the values at which

designated process outputs-controlled variables (CV) should be maintained. The process input variables that are changed by the controller to achieve and maintain the specified operating point are the manipulated variables (MV). The task of any controller can thus be divided into :

- * Servo Control : where the controlled variables have to track a specified trajectory or achieve a setpoint.
- Regulatory Control : where no servo control is required, but control action is initiated to reject the effect of disturbances that drive the CVs away from setpoints.

In actual implementation control tasks usually combine servo and regulatory functions.

ON-LINE ANALYSIS SYSTEM

The flotation is subjected to a wide variety of process disturbances as explained earlier. In addition, the flotation process is non-linear, time varying with response characteristics highly dependent upon ore type. Some of the variables are controllable by the metallurgist provided he has means to know the changes occurring immediately. On-line sensing instruments have been developed for measurement of variables which allow calculation of performance, e.g., XRF analysis, gamma density gauges and electro-magnetic flow meters. The on-line XRF analyser system is the main instrument which helps to determine the changes occurring in variables and allow to compensate and stabilise the process.

Technique

Primary X-rays from an excitation source interact with the structure of the atoms of the process material. The major effect is ejection of photo-electrons from one of the inner, i.e., K or L shells. Fluorescent X-rays are useful for elemental analysis because each element has a unique set of fluorescent X-rays which may be characterised according to their energies. A spectrometer is used to separate fluorescent X-rays from a process material according to energy. In this way, identities of the elements may be determined.

Determination of the intensity (i.e. number of X-rays) at each fluorescent X-ray energy provides a measure of the concentration of the element that produced the associated X-rays. A system that

combines the above components with appropriate sample presentation and operation interface can provide on-line elemental analysis.

Components

All on-line XRF systems have the following major components :

- a) Sample presentation - either take the analyser to the stream or bring a portion of the stream to the analyser.
- b) Excitation Source - Radio isotope or X-ray tube.
- c) Spectrometer - Energy Dispersive or Wave Length Dispersive.
- d) Operator Interface - Menu driven or Command driven.

Available Systems

The popular systems available are :

- a) Centralised X-rays system
- b) Near stream system, and
- c) In-stream probe system

Centralised X-ray System

- (i) One of the earliest on-stream systems was the Outokumpu's Courier 300 (Fig. 1). It is a central analyser in which all the pulp samples are pumped to a central location with the rejects being returned to the process. The standard unit accommodates upto 14 separate flow cells for measurement of the slurry stream. Fixed angle x-ray spectrometers are used to measure the characteristics of upto five elements. The element range is titanium to uranium.
- (ii) Boliden's Boxray 16 on-stream analyser system, like the Courier 300, has a central analysis station. The flow cells are arranged in cylindrical fashion around a vertical axis which makes a compact arrangement. The presenter moves step-wise around the vertical axis following pre-set programme. The basic capacity of Boxray-16 is 16 pulp streams. The element range is potassium to uranium.

Near Stream System

- (i) The smaller Outokumpu Courier 30 is near central analyser. The basic five stream model is available as a microprocessor controlled

version. The spectrometer design is basically the same as for the Courier 300. Being a compact, stand alone arrangement it can be positioned close to the streams to be measured, so minimising the length of sample pipe lines.

- (ii) Armco Automatrix XRA 1500 is a near stream analysis system and each probe has its own error diagnostic micro-computer. By using a combination of units available for one, three and six streams, upto 15 streams can be accommodated. Assays and spectrums are communicated to XRA 1500 central station via simple twisted pair cables upto 1 km long.

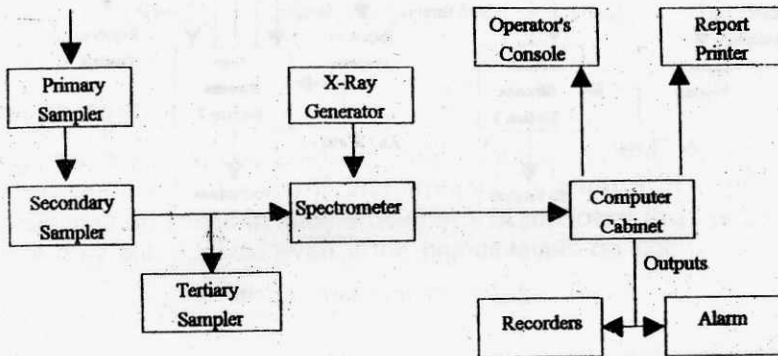

Fig. 1 : Courier 300

- (iii) Boliden Boxray compac has a capacity of 1 to 8 pulp streams and is designed for installation in the process environments.
- (iv) For small and medium sized plants, Outokumpu have developed two near stream analysers using radio-isotopes, Minexan 202 and Minexam 5. Upto five elements from each of two slurry streams can be measured and the system is readily expandable to meet the exact requirements of any plant. The element range is calcium to uranium.

Fig. 2 shows general arrangement of near stream system

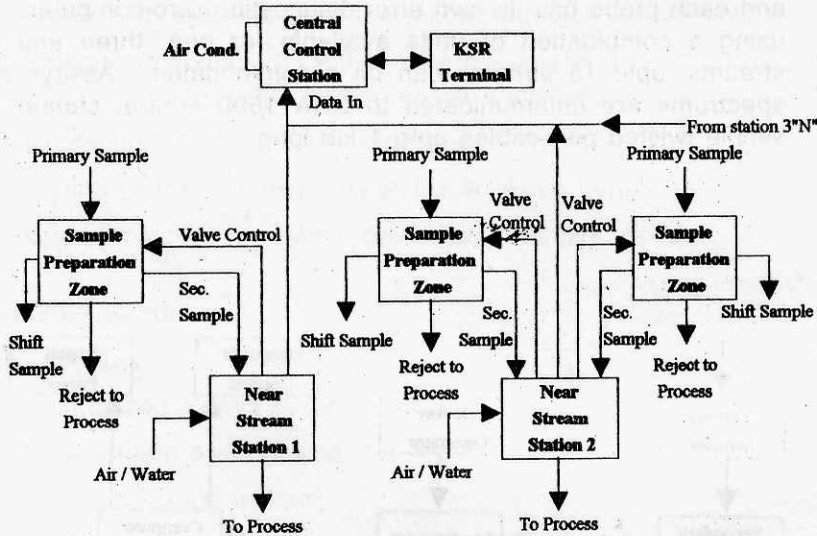

Fig. 2 : Near stream system

In-stream Probe System

- (a) Texas Nuclear's Inscan is an in-stream system. Each probe uses XRF with a low activity radio-isotope source to measure elements of interest and slurry density. All elements with atomic number higher than 16 (sulphur) can be measured.
- (b) Pioneers in the development of in-stream analysis systems are the Australian Mineral Development Laboratories (AMDEL). Their original system (Fig. 7) consists of a range of immersible probes, one for each element. Copper, nickel, iron, tin and zinc are measured with X-ray fluorescence probes. Gamma ray preferential absorption probes are used for the determination of the higher atomic number elements (lead, tungsten, bismuth, uranium, etc.) and to measure slurry density. Where multi-element capacity is

required, or where concentration to be measured are extremely low, a solid state probe can be used.

Mineral content and pulp density information in the form of electrical signals, is fed back to a small digital computer in the central control room.

THE AUTOMATIC CONTROL OF FLOTATION CIRCUITS

The process control with the help of computer also started after development of on-line analysis system, following simple control strategies with PID forward and feed backward control loops to stabilise the process. The viability of beneficiation plants, treating low grade and complex ores available now-a-days, depends on high efficiencies for which automatic control systems are mandatory. Before its development, the objectives of a control system need to be clearly defined. Some of the common objectives are to maximise the throughput, recovery, concentrate grade etc. and minimise the reagent consumption.

Level of Control

There are mainly three levels of basic control systems - regulatory control, supervisory control and optimising control. These three controls may be linked in such a manner that the lower level regulatory control may still operate even if the higher levels do not.

Process Control System

The general process control consists of the following components (Fig. 3) :

Control Room Equipment

The control room equipment provides process data easily to the process operator through displays, reports, alarm, printers and recorders. The operator controls the process by using functional key board.

Operator Interface Unit

This provides colour video displays, printer outputs and control facilities. It forms a flexible process monitoring and control system. The functions of the operator station are configured in an interactive dialogue.

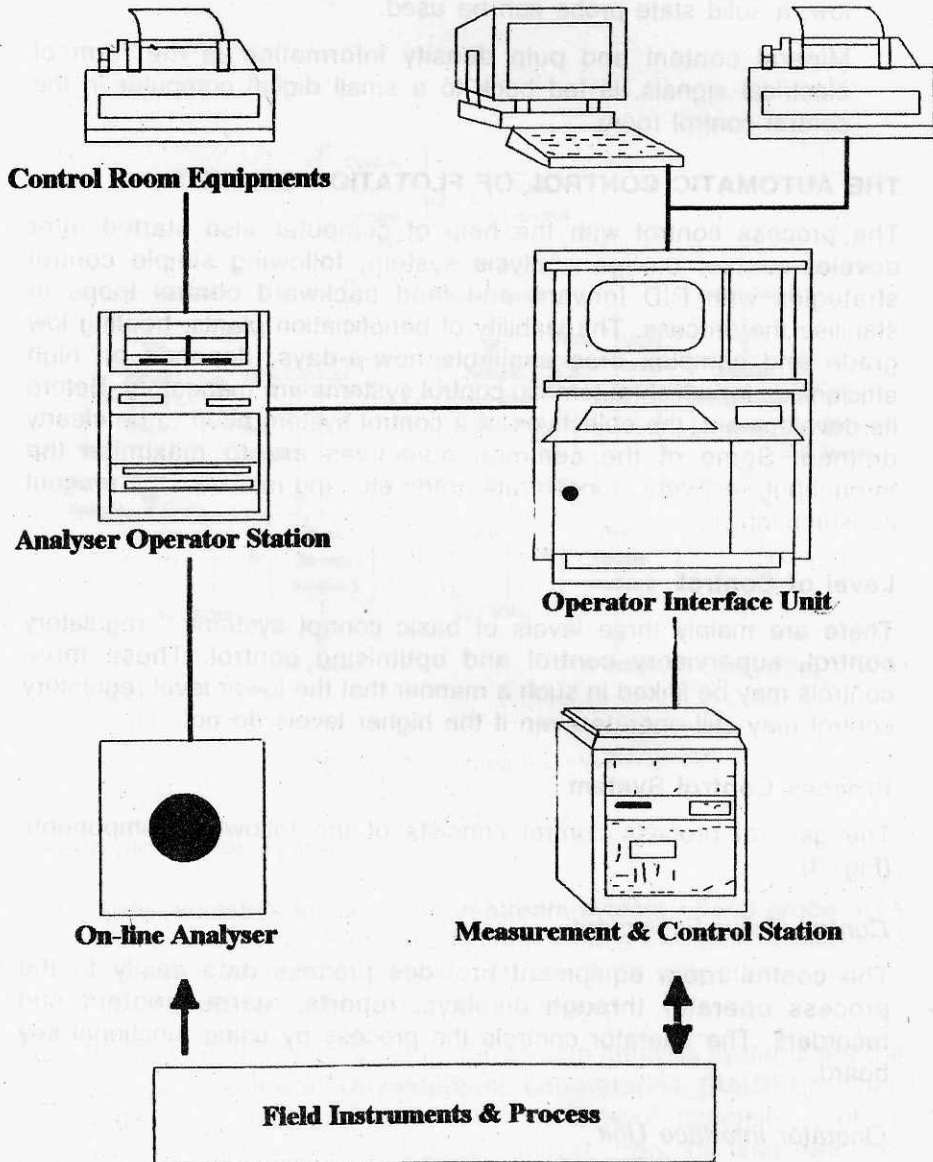

Fig. 3 : On-line analysis and process control

Measurement and Control Station

This is generally microprocessor based data acquisition, multi-loop controller and sequencing functions. A flexible process interface connects field instruments with the system.

Field Instruments

Typical field instruments are used to monitor water and slurry flows, densities, pH, pulp level, flotation machine air flows, reagent consumption, grinding mill power consumption, particle size etc.

Unit Operations

The unit operations like crushing, grinding and flotation are generally carried out with process control system.

Crushing

Modern crushing plants use controlled feed rate and variable setting to get optimum particle size. Power consumption of crushers, flow of material through crushing stages to ore bins and the bin discharge system are monitored and controlled. The objective is to produce a specified product size at maximum throughput without over-loading the system.

Grinding

Typical process variables monitored and controlled are :

- Crushed ore/ lump feed rate
- Water feed to mill and cyclone pump sump
- Cyclone pump sump level
- Cyclone feed and overflow density
- Cyclone feed pressure
- Mill power consumption or power oscillation
- Particle size and pulp density of cyclone overflow.

The control and measurement points are inter-connected with each other so that best overall result is achieved. Usually the feed rate is optimised with respect to cyclone overflow product size.

Flotation

Variables usually monitored and controlled are :

- Assays from on-line analyser
- Water and slurry flows
- Pulp densities
- pH values in flotation circuits
- Pulp levels and air flows in flotation machines
- Reagent feed rates.

Advantages

The advantages of on-line analysis system with automatic process control system include increase in recovery and throughput, decreased reagent consumption, reduced circulation flows, uniform grade of end products and better management information in the form of real time reports, trend curves and history displays which gives ideas for making further improvements in the plant operations.

ADVANCE PROCESS CONTROL

With advancement in computer technology, and with the aim of not only to stabilise the process but also to optimise the economic efficiency, adaptive optimisation method has been evolved. It requires a model or method to calculate overall efficiency which quantifies plant performance. The recent development in process control is Expert system based on fuzzy logic of the strategy used by the experienced plant personnel and do not require accurate models.

Advanced supervisory process control techniques have been widely used in chemical process industry over the past 15 years. The flexibility to incorporate process constraints, dead times and nonlinearities into explicit multivariable designs coupled with the robustness of control strategies has contributed significantly to their success. However, mineral processing facilities remained largely unaffected by these developments in chemical process control, despite the challenging control problems posed by dynamically complex unit operations such as comminution and flotation, typically encountered in mineral processing plants. Many of these processes are still controlled by low-level PI or PID controllers. Given the potentially large operational benefits - primarily in crucial areas of throughput maintenance, product grade improvement and energy savings — to be gained through

advanced control, several mineral processing facilities are currently in the process of evaluating and implementing these strategies.

Multivariable Supervisory Control

Supervisory control is based on providing setpoints to a number of lower level controllers. In a plant, single supervisory controller may be used to govern control actions over a process unit or a collection of units. When several loops are being controlled the controller is termed multivariable. Advantage of multivariable control is that when a MV value is computed and changed in one loop, the effect on all CVs in the supervisory setup is accounted for. This minimizes interloop oscillations resulting from opposing control actions on the same variable.

Knowledge-based Control

Objective in the design philosophy is to provide a customized design for the application being considered. Its advantage over the standardized advanced control software is that the performance of the controller can be explicitly tailored to the needs of the application at the design stage itself.

Model Predictive Control

In the late 1970's, a set of heuristic model-based control algorithms were implemented within the oil refining industry laying foundation for the host of digital control algorithms collectively known as model predictive control techniques (MPC). It is based on running dynamic model of the process on-line in parallel with the actual process. The on-line model may be rigorous nonlinear model or a linear parametric model, and is usually installed and run on the host computer for the MPC control software. The control move computation is carried out at each sampling instant.

Structural difference between model-based techniques and PID is illustrated in Figs. 4(a) & 4(b).

Adaptive Control

The need for adaptive control arises from nonlinearity of processes and limited range of validity of linear models in describing these processes. At the same time, linear models offer significant advantages in terms of computational ease, crucial in real time application of control

strategies. Adaptive control is based on parameter estimation theory, where a fixed number of model parameters are estimated on-line so as to minimize the error between model prediction and measured CV values. Linear model parameters are thus modified dynamically, providing a closer description of nonlinear behaviour of the process.

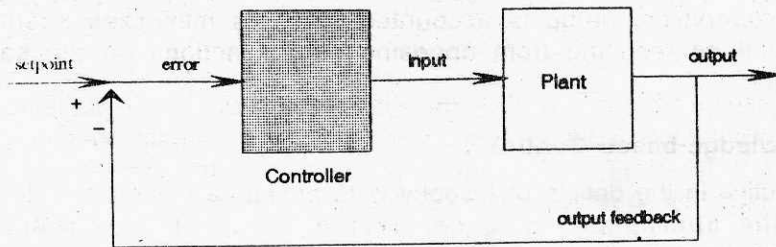

Fig. 4(a) : PID block diagram

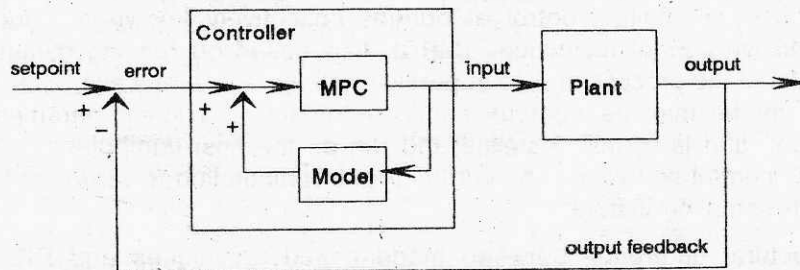

Fig. 4(b) : MPC block diagram

Fuzzy Logic

Fuzzy logic can be used effectively to impose restrictions on the controller output (MVs) by using rule bases to override the MPC solution when it lies in undesirable operating regions. Rule bases also

play an important role in incorporating operating heuristics into the overall control design.

Neural Networks

Artificial neural networks (ANN) are used in improving the prediction properties of the MPC algorithm, particularly in systems that exhibit periodic dynamics not effectively captured by the process model. Advantage of neural networks is that they can be trained on difficult to model transient data in regulatory control.

Model-Based Expert Control (MBEC) System

MBEC is supervisory control systems usually installed to supplement a DCS (Distributed Control System) in a separate computer or embedded in a plant MIS (Management Information System). Operators do not normally need to interact with them and can do it through the DCS. It combine the power of phenomenological process models and flexibility of heuristic (rules-based) systems for achieving optimized supervisory control of naturally complex mineral processes. Fig. 5 shows the software structure of MBEC system. It consists of two sets of modules : modeling modules and expertise modules.

Modeling Modules

Core of modeling modules is the dynamic model of process, which continuously calculates and predicts the state of the process. At a given time, the state of the process is known from a dynamic process model and filter. An optimizer uses this information to predict steady state of the process which would be established if no external disturbance happened and for any combination of set points of local loops. This prediction is used to infer optimized modifications of set points for achieving the best possible performance in near future.

Expertise Modules

Expertise modules consist of sets of rules coded in an appropriate real-time shell which extensively use information generated by the modeling modules and express a realistic strategy for running the plant.

The analysis of data collected in model-based and in DCS control mode over a long period of time allows an objective evaluation of benefits generated by the system.

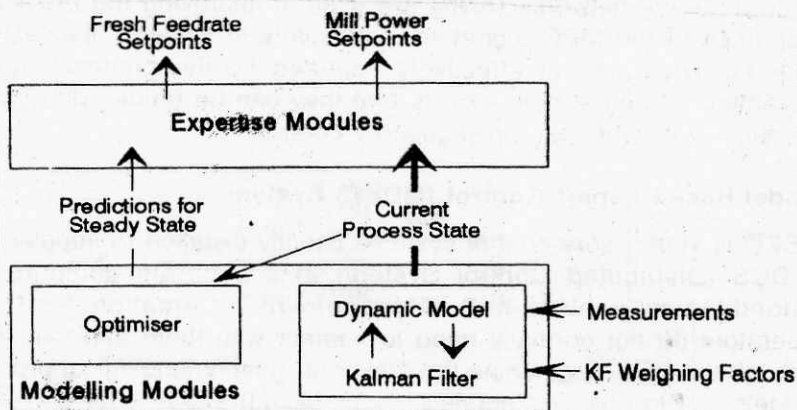

Fig. 5 : Software structure of the MBEC system

PROCESS CONTROLS IN HZL BENEFICIATION PLANTS - CASE STUDY

In-stream Analyser and Process Control Systems

HZL successfully installed on-line analysis and computerised process control system first time in India in 1989 at the Balaria mill of Zawar Mines and extended it to Mochia mill of Zawar Mines and Rajpura Dariba Concentrator in 1993. ISA system was installed since inception at Rampura Agucha Beneficiation Plant in 1991. The flowsheet of Balaria mill, where In-stream analyser (ISA) with computerised process control system was introduced, is shown in Fig. 6. Complete system comprises of three major elements (Fig.-7) :

- (a) In-stream analysis system,
- (b) Field instruments, and
- (c) Digital process control system.

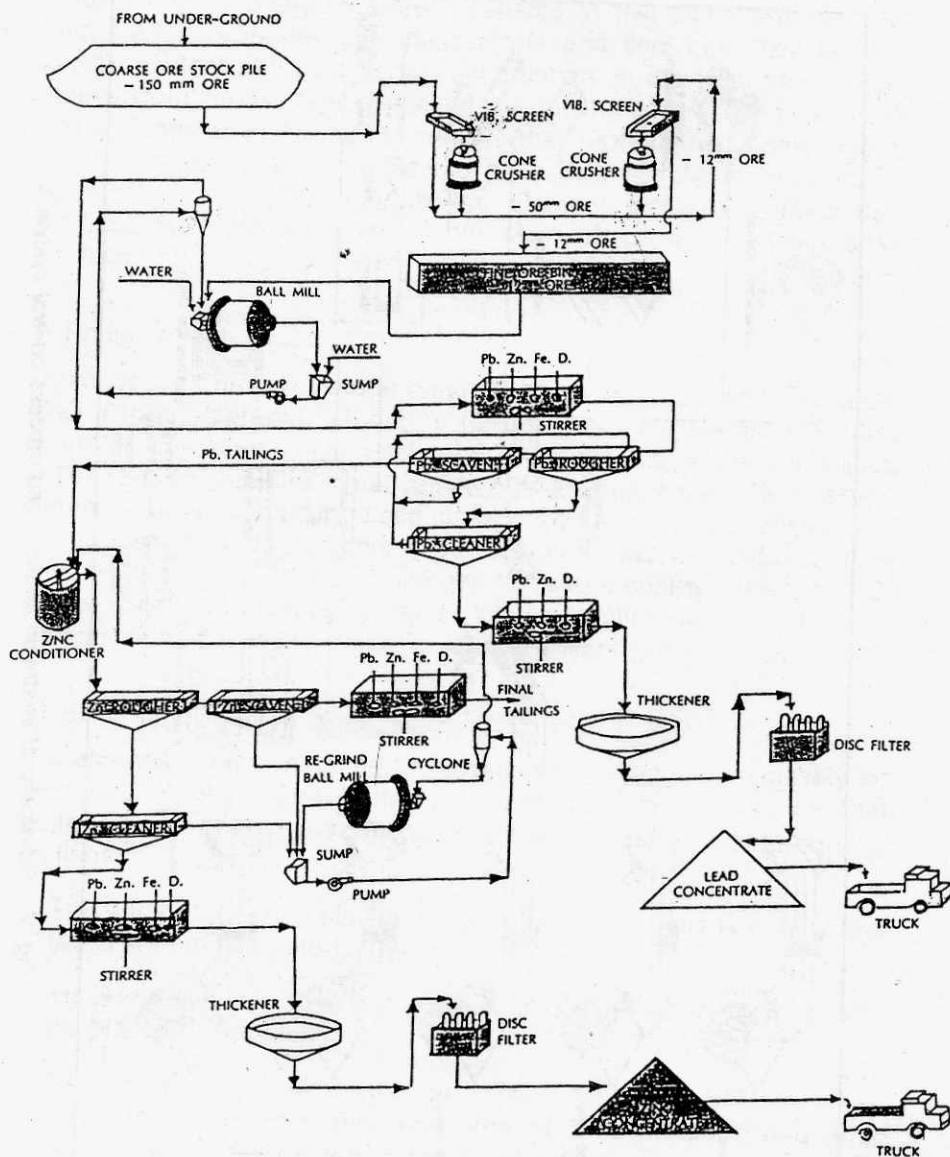

Fig. 6 : Balaria Concentrator flow-sheet

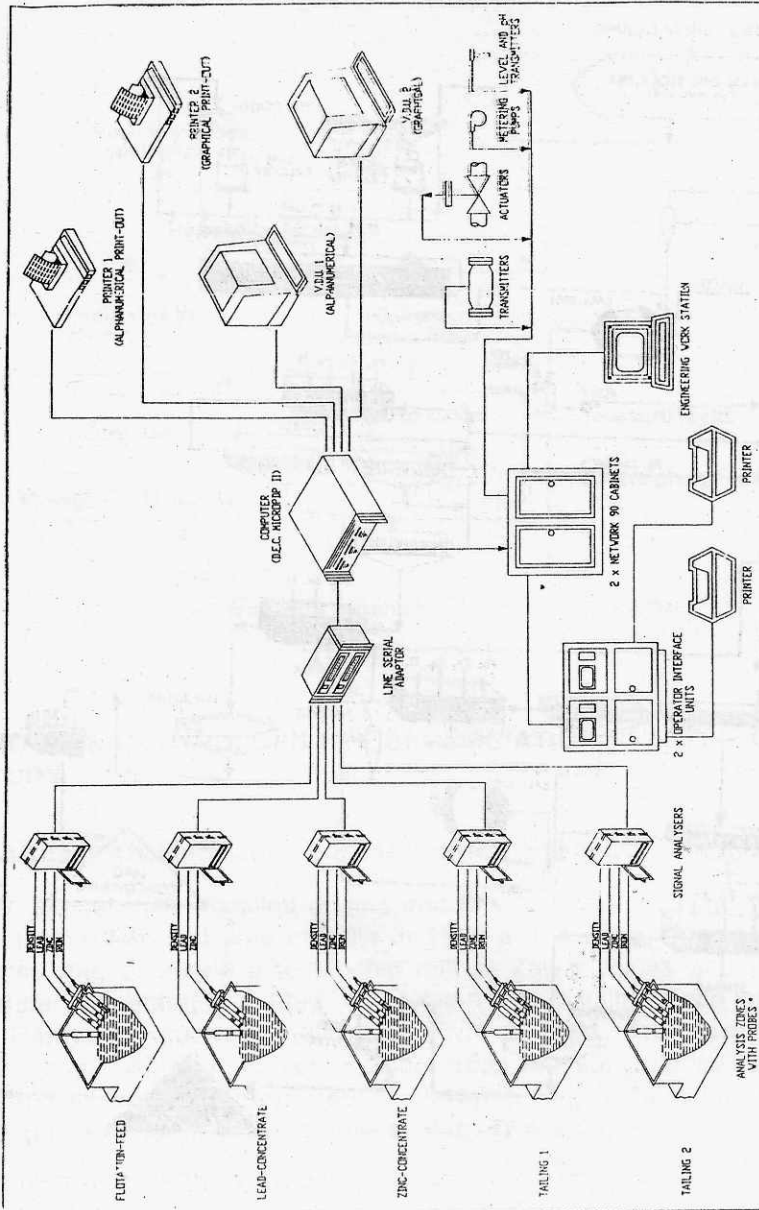

Fig. 7 : Schematic of in-stream analysis and process control system

In-stream Analysis System

In-stream X-ray analyzer employ sensors in five slurry streams viz, feed, lead concentrate, zinc concentrate and final tails (two points). Mineral content and pulp density information, in the form of electrical signals from probes are conveyed via electronic circuits to a small digital computer in the central room. After programmed computation, continuous print out of analytical data is available for manual or automatic control of flotation process. Elements analyzed continuously are lead, zinc, iron and pulp density. Main components of the system are following :

(i) Radio Isotope Probe

Three types of probes used at different points include Direct Excitation (DE) Probe, Detector Radiator (DR) Probe and Density Probe. However, the latest single solid state multielemental probe is installed at RD Mine to measure metal values of lead, zinc, copper, iron, silver, cadmium and pulp density. Solid state probes has greater sensitivity to low concentration of elements due to its high X-ray spectral resolution and needs a supply of liquid nitrogen to keep it cool to about -150°C . Alarm system is provided to detect low liquid nitrogen level. Average consumption of liquid nitrogen is about 20 liters per probe per week.

(ii) Analysis Zones

The analysis zone is required to provide well mixed and relatively air free pulp. It is important that the velocity of slurry is such that segregation does not occur. A typical analysis zone contains four major sections

- The entry and mixing section absorbs small fluctuations in flow and feeds well mixed pulp to deaeration section.
- The deaeration section provides sufficient retention time for the entrapped air to escape.
- The analysis section houses immersion probes and stirrer. It is designed to produce retention time of 5-15 seconds and pulp velocity of 0.3-0.5 m/sec. to prevent sanding.
- The discharge section collects pulp from analysis section and transports the pulp to next stage in the process.

(iii) Signal Analyser

The electronic signal output from the immersion probes is processed in signal analyser mounted near to analysis zone.

(iv) Line Serial Adopter (LISA)

Situated close to the micro-computer in control room, LISA accepts output signals from the signal analyser for each probe and converts it into computer compatible TTL signals.

(v) Control room Equipment

A digital micro PDP-11/32 computer accept signals from LISA, converts them into count rate and calculates actual metal assays and pulp density from pre-determined calibration equations at 5 minutes interval.

Field Instruments

Field instruments consist of the following :

- pH probes, transmitters and actuators
- Level probes, transmitters and actuators
- Magnetic flowmeters and control valves
- Reagent dosing pumps.

- (i) The pH of slurry to zinc flotation circuit has a two stage control. First stage is controlled by measuring the pH at feed box to rougher circuit and adding milk of lime to the conditioner. Second stage of control is achieved by measuring the pH at the end of third cleaner cell and adding milk of lime to overflow launder of second cleaner cell.
- (ii) The level of the scavenger bank of cells in both lead and zinc flotation circuits are automatically controlled by regulating the dart valve on the outlet of these banks.
- (iii) Copper sulphate and zinc sulphate reagent addition control loops in each circuit are identical and consist of a magnetic flowmeter to measure the reagent flow and a control valve for regulation.
- (iv) Potassium ethyl xanthate, sodium isopropyl xanthate, sodium cyanide and cresylic acid reagent addition control loops in each circuit are identical and consist of automatic regulation of positive displacement reagent pumps.

Total flow of each of these reagents other than the cresylic acid is measured by means of a magnetic flowmeter. Cresylic acid flow is measured by a turbine meter.

Digital Control System (DCS)

Modern DCS are microprocessor based and capable of addressing a wide variety of process control strategies. Inside each controller module, a powerful library of pre-defined control function codes is available to implement virtually any control strategy from the simplest PID function to complex multi-loop algorithms.

The DCS used for Zawar application is a Network 90 system manufactured by M/s Bailey Controls. However, at RD Mine, the latest Network INFI 90 system has been installed. The system consists of two Operator Interface Units (OIU's) with dedicated operator key boards, a Process Control Unit (PCU) to which the field input and output signals are connected and a data highway over which the OIU's and PCU communicate. Configuration of the DCS can be accomplished via OIU or an Engineering Work Station (EWS) which consists of an IBM PC or compatible, in which Bailey's configuration software is run in three phases, namely Drawing phase, Cross reference phase and Compilation phase.

Control Practice

The reagent flow control, cell level control and pH control is carried out as follows :

- (i) Reagents flow control is done either by a control valve in feed back loop or through dosing pump. Magnetic flowmeter provides a feed signal to compare with a set point in the centralised control system and the difference is used to generate an output signal to the valve. The diaphragm actuated dosing pumps provide an accurate, variable reagent flow rate without separate measurement as per the set point.
- (ii) Cell level control of individual rougher/scavenger cells is done by pneumatically actuated draft valves which regulate the outflow of each cell bank. These level loops use a feed back signal. Cell levels are measured and compared with the established set points in the centralized control system.
- (iii) pH control in zinc rougher and cleaner cells is achieved by regularly actuating the delivery nozzle to the splitter box for a

period of time proportional to desired average dosing rate of lime at various points in the circuit.

Control Using In-stream Analysis Data

The control objective is to maximize lead and zinc recovery with final concentrates grade not falling below the minimum values. Development of schemes has centered on providing elementary loops to control reagent flow, cell level and pH. Automatic control of reagent dosing is achieved by utilizing both feed forward and feed back control techniques for some reagents and feed forward for the balance. The DCS calculates correct dosing rate of reagents based on ISA data of metal in flotation feed and tailings slurry. Set points of reagent addition controllers are regulated to achieve an optimum controller value of %metal in tailings. It results in avoiding under or over use of reagents and minimising metal loss in tailings. Some of the relationships configured and adopted are shown in Figs. 8(a) and 8(b).

Benefits Achieved from ISA & Process Control System

Major benefits are reduction in reagent consumption and improvement of concentrate grade as well as recovery. Other benefits include assistance in plant auditing & experimentation and reduction in water & power consumption.

Thus, installation of In-stream Analyser and Process Control System proved cost effective in the Concentrators of HZL.

Grinding Circuit Control

Particle size control is a major variable in improved grinding circuit control. It improves cost effectiveness of grinding process. When finer than necessary, throughput is reduced and power, grinding media and liner consumption is increased in addition to downstream difficulties in floating finer particles. On the other hand, if the grind be too coarse, recovery is reduced. In either case, the revenue is lost.

PSM-400 Particle Size Monitor

This instrument was first time introduced at Zawar Mines as well as RA Mine. It determine particle size and % solids by precise measurement of the attenuation of ultrasonic energy passed through a representative sample flow stream. The instrument consists of air eliminator, sensor and electronics section. A slurry sample is drawn continuously from

the process flow stream into air eliminator. The sample passes through the sensor section where actual measurement of size and solids are made and then it returns to the main process flow stream. Electrical signals received from sensors are processed in electronics section. By simple keyboard commands and using the Control Unit, the operator can set low and high limits for the 4-20 mA current loop outputs.

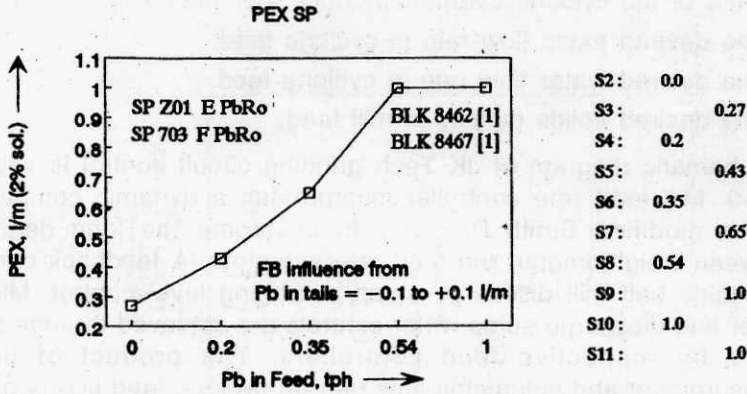

8(a)

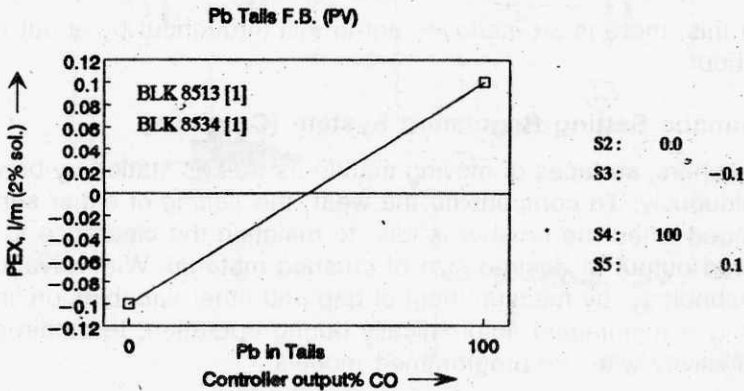

8(b)

Fig. 8(a) & (b) Relationship configured for automatic addition of reagents

Automatic Grinding Circuit Control

This system from JKTech, Australia has been incorporated at RD Mine. The design of control strategies for the grinding circuits has been developed with an overall objective of maximizing mill throughput within operating constraints. To achieve it, control strategies with the following individual objectives have been implemented to maintain

- 70% of the cyclone overflow product finer than 75 μ .
- the desired mass flow rate in cyclone feed.
- the desired water flow rate in cyclone feed.
- the desired solids density in mill feed.

A schematic diagram of JK Tech grinding circuit control is shown in Fig.-9. Mill feed rate controller incorporates a dynamic compensator and a modified Smith Predictor to overcome the long dead time between weightometer and feed rate actuators. A feedback controller maintains ball mill discharge sump averaging level control. Mill feed water and discharge sump water controls are achieved through control valve by respective feed controllers. The product of density measurement and volumetric flow rate on cyclone feed line is process variable to the PID mass flow rate control. Its output is the set point to mill feed rate controller. In addition, regression models have been produced from JK SimMet for cyclone underflow density and product size controls.

With this, there is an improvement in mill throughput by about 2-3 MT per hour.

Automatic Setting Regulation System (Crushers)

In crushers, surfaces of moving mantle as well as stationery bowl wear continuously. To compensate the wear, the *setting* of either surface is changed when the crusher is idle, to maintain the clearance to obtain desired output at desired size of crushed material. With advancement in technology, by measurement of gap and other variables on line, this setting is maintained automatically during operation, to obtain optimal productivity with pre-programmed models.

The motor load is measured by an energy meter and the load inside crusher is measured by a pressure transducer which registers the pressure in Hydroset system. Similarly, the crusher's setting is continuously measured by sensing main shaft position. Variations in these values are fed continuously into a computer. For each crusher

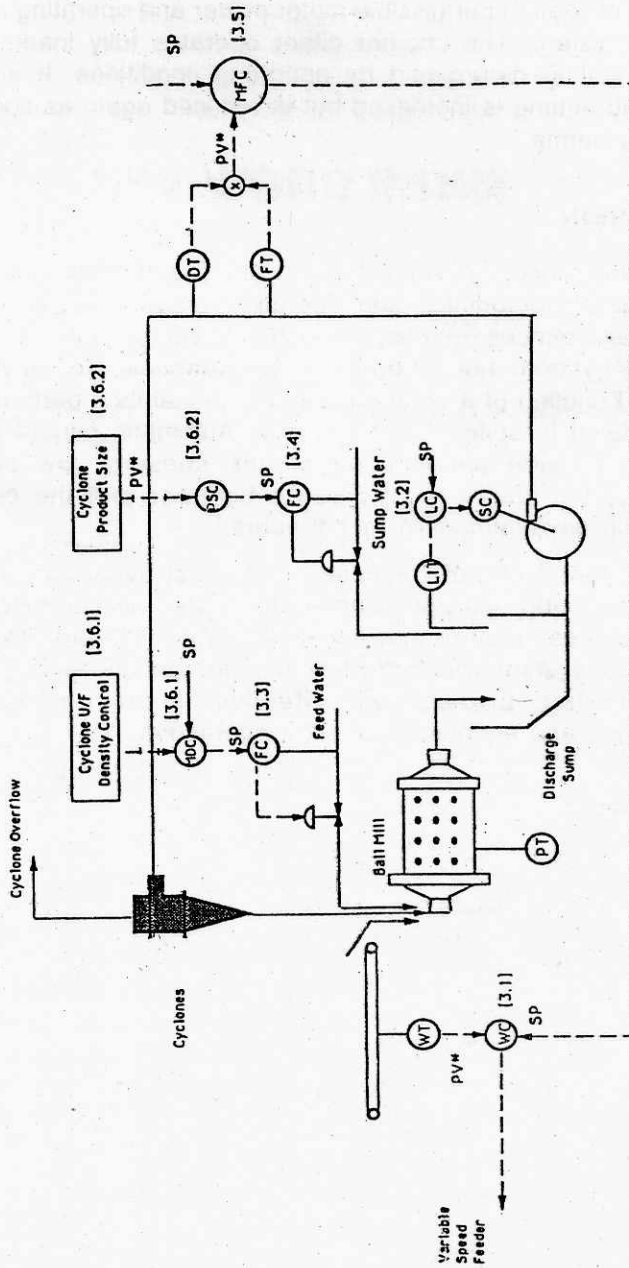

Fig. 9 : Schematic diagram of grinding circuit control schemes

Note : PV* indicates control schemes with dynamic compensation

there is a maximum permissible motor power and operating pressure in Hydroset system. The crusher either operates fully loaded or at an optimum setting determined by operating conditions. If an overload occurs, the setting is increased but is reduced again as soon as load conditions permit.

CONCLUSION

The flotation process is subject to process disturbances due to change in mineral characteristics and operating procedures. It is better to prevent disturbances from occurring than to compensate for them using a control system, but in practice disturbances are inevitable and frequent. Function of a control system is to maintain performance at a required level in spite of disturbances. Automatic control of flotation circuits was made possible by on-line sensors, low cost digital computers, the knowledge of process behavior and the cause-effect relationship development in recent years.

HZL has started use of computers in mineral beneficiation plants for control, modelling and optimization of circuits. Initially, fully automatic flotation process control was installed at Zawar Balaria Concentrator and similar system was provided in other beneficiation plants. The control system proved cost effective, improved metallurgical performance and economics of plant operations.