



Copyright © 2013 by American Scientific Publishers
All rights reserved.
Printed in the United States of America

Journal of Nanofluids
Vol. 2, pp. 1–4, 2013
(www.aspbs.com/jon)

Boiling Study of Nanofluid on Graphene Coated Substrate

Shyam K. Choudhary^{1,*}, Manish Kumar Bhadu¹, Akshya Kumar Guin¹,
A. K. Pramanik², Nabarun Ghosh¹, Tapan Kumar Rout¹, and Sumitesh Das¹

¹R&D and Scientific Services, TATA Steel Ltd., Jamshedpur 831001, India

²National Metallurgical Laboratory, Jamshedpur 831007, India

A comparative study is done to understand the effect of variation in surface energy of substrates on boiling and dry-out characteristics of nanofluid. Droplet of TiO₂ nanofluid on glass substrate shows strong pinning along the droplet perimeter. As the droplet evaporates, boundary of nanofluid droplet recedes slowly towards the center leaving a ring-shaped stain of concentrated nanoparticles. Surface energy of glass substrate is modified by graphene coating, confirmed by increase in contact angle. While boiling of nanofluid on graphene coated glass substrate shows an almost uniform dry-out pattern. Reduced wettability of nanofluid droplet on graphene coated glass substrate is responsible for this behavior.

KEYWORDS: Nanofluid, Boiling, Wetting, Heat Transfer, Graphene, Nanoparticle.

1. INTRODUCTION

In recent years, industries have witnessed a technological trend to accelerate the production process with high accuracy. Removal of heat is an important part of many production processes. This has posed a significant challenge for research community to develop an effective way of fast cooling. Advancements in the field of nanoparticle synthesis and their colloidal suspension have been phenomenal to resolve this problem.¹ Colloidal suspensions of nanoparticles into liquid also known as nanofluid has shown improved thermal conductivity and the convective heat transfer coefficient compared to the base liquid.²⁻⁴ The high surface area to volume ratio of nanoparticles not only improves heat transfer ability but also increases the stability of suspensions. There are various models available which attempts to understand the physical mechanism of heat transfer through nanofluids. Two of such models are discussed by Maxwell et al. (1904) and Hamilton et al. (1962).^{5,6}

Many industrial processes require application of heat transfer liquid in the boiling regime. It has been observed that nanofluid shows an enhancement in critical heat flux compare to base fluid in pool boiling experiments. This enhancement is most likely due to modification of surface wettability caused by deposition of nanoparticles on the heated surface as discussed by Chaudhury (2003) and

Wasan et al. (2003).^{1,7} Nanoparticles get deposited on the heated surface if surface temperature is high enough to evaporate the liquid of nanofluid. Several investigations have been tried to understand the evaporation and dry-out characteristics of nanofluid droplets. Chon et al. (2007) have studied the effects of nanoparticle size on dry-out patterns of nanoparticles.⁸ They have found that droplets of nanofluid show strong pinning along the droplet perimeter and, upon evaporation, leave a ring-shaped nanoparticle stain. Chen et al. (2010) have shown that as the droplet of nanofluid evaporates its increasing particle concentration influences the rate of evaporation.⁹

Here we have studied the effect of variation in surface energy of heating surface on the evaporation and dry-out characteristics of TiO₂ nanofluid's droplets. Surface energy of glass substrates has been altered by graphene coating. We have found that during boiling on glass substrate, boundary of nanofluid droplet recedes slowly towards the center leaving a ring-shaped stain of concentrated nanoparticles. While dry-out pattern of nanoparticles on the graphene coated glass substrate is almost uniform. We believe that reduced wettability of nanofluid droplet on coated glass substrates is responsible for this behavior.

2. EXPERIMENTAL DETAILS

A schematic of experimental setup is shown in Figure 1 reproduces from an article described elsewhere by Choudhary et al. (2012).¹⁰ We have used a ring shape heater (50 W) with outer and inner diameters, 37 and 15 mm, respectively which holds the glass substrate of

* Author to whom correspondence should be addressed.

Email: shyamkcx@gmail.com

Received: 18 March 2013

Accepted: 21 May 2013

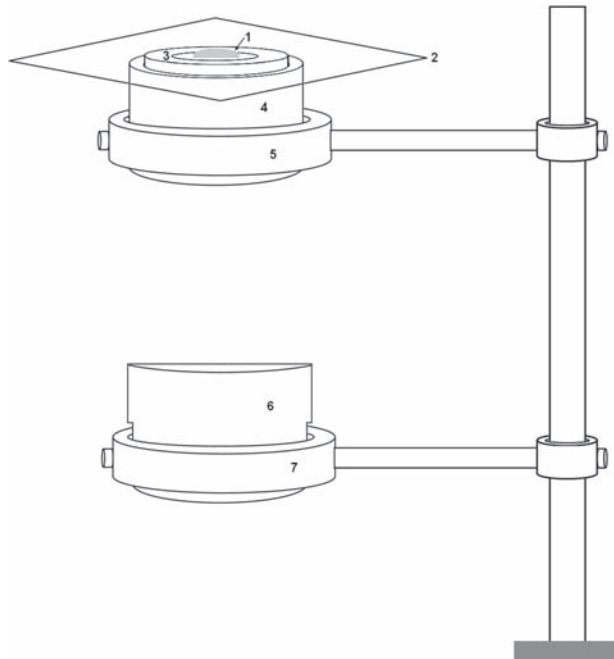

Fig. 1. A schematic of the experimental setup: (1) a droplet of nanofluid, (2) transparent horizontal substrate, (3) brass ring, (4) ring shape heater, (5) clamp for holding heater, (6) high speed camera, and (7) clamp for holding camera. Reproduced with permission from [10], S. K. Choudhary, et al., *J. Nanofluids* 1, 196 (2012). © 2012.

1 mm thickness. A camera with frame rate of 60 f/s is mounted vertically downward to the glass plate which can take pictures from bottom. For doing measurements, we place a small droplet (10 micro liter) of nanofluid on glass substrate. We then focus the camera at the contact area of droplet and substrate. Experiments were done by heating the substrate for a maximum temperature of 107 °C. As heating is done by ring heater, there will be a small temperature gradient on glass plate.

TiO₂ nanofluid with 1% weight fraction was prepared by adding poly-dispersed TiO₂ nano-particles (size 50–80 nm) into de-ionized water followed by 30 minutes of ultrasonication using a 100 W and 40 kHz ultrasonicator. We did not use surfactant in nanofluid preparation because dispersion of nanoparticles in the solution was good during the experiment. Graphene was prepared by chemical method which includes oxidation and reduction of graphite described by Hummers et al. (1958) and Pham et al. (2012).^{11,12} For graphene coating, a small amount of graphene was dispersed in isopropyl alcohol. Few drops of graphene solutions were casted on the glass substrate and dried in ambient conditions. A homemade goniometer was used to measure the contact angle of droplets.

We have characterized the graphene by taking optical image on 300 nm SiO₂/Si substrate as shown in Figure 2(a). Graphene solution was drop casted on SiO₂/Si

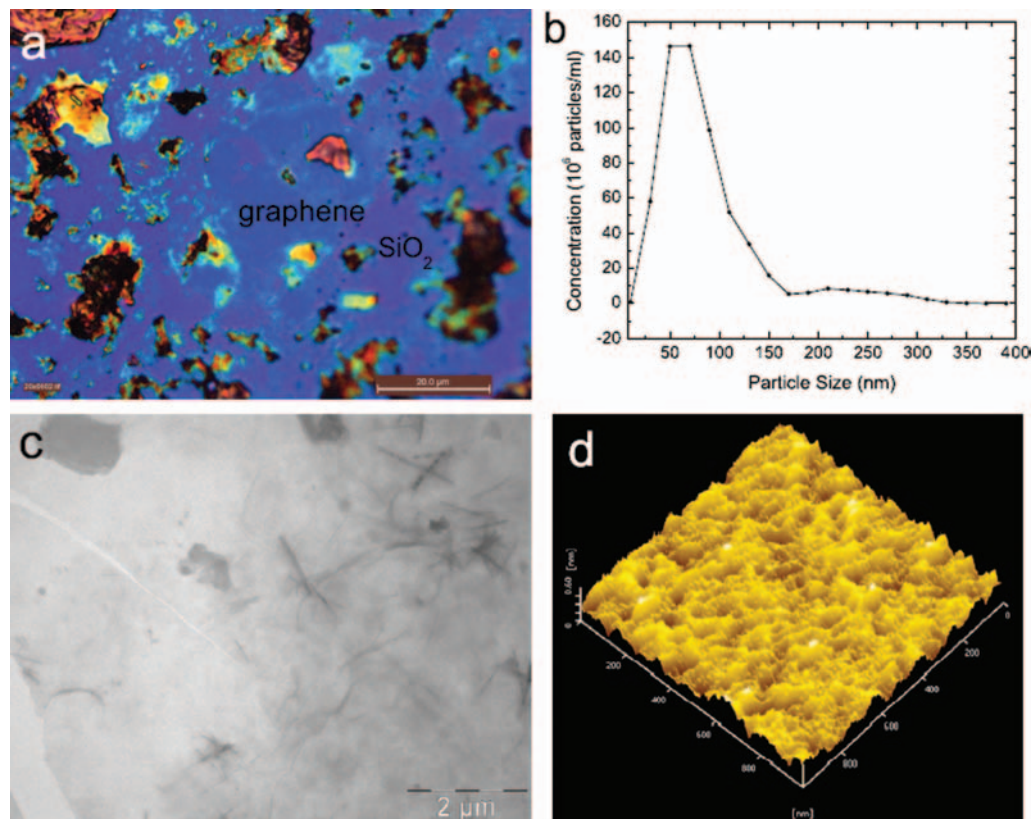

Fig. 2. (a) Optical image of graphene on 300 nm SiO₂/Si substrate. (b) shows variation of size of graphene nano flakes with concentration of graphene in isopropyl alcohol solution. (c) A TEM image of graphene. (d) An AFM image of graphene showing ripples with average roughness of 0.36 nm.

substrate and image were taken by optical microscope. Small graphite flakes are also present in the solution as can be seen in this image. Further, we have characterized graphene solution by using a particle analyzer. Figure 2(b) shows size distribution of graphene nano flakes with average size 85 nm. Since this instrument is only sensitive to nanoparticles of size less than 1000 nm, so size distribution data only ensures the presence of nano flakes in the solution. Moreover, the instrument is based on light scattering technique and Brownian motion of particles; this will only provide information for spherical equivalent of the nano graphene flakes. The spherical equivalent may be an overestimation due to the additional drag from flakes compare spheres but it should at least get an estimation of size and data on concentration. Figure 2(c) shows TEM image of graphene sample. Figure 2(d) is an AFM image of graphene on 300 nm SiO₂/Si substrate which shows ripples of graphene with an average roughness of 0.36 nm.

3. RESULTS AND DISCUSSION

Figure 3 shows droplet of nanofluid on glass and graphene coated glass substrate with values of contact angles mentioned in the panel. From this image it is clear that nanofluid wets more bare glass in comparison to graphene coated glass. For boiling study, a small droplet (10 micro liters) of nanofluid was placed on the glass substrate and heater was turned on. Boiling experiment on graphene coated glass was done similarly by changing the substrate on the heater. Figures 4(a) and (b) show stable droplets of nanofluid on glass and graphene coated glass, respectively. Since these images are taken from the bottom of the substrate, bigger graphite particles is also visible in Figure 4(b). Figures 4(c) and (d) show dry-out pattern of nanofluid on glass and graphene coated glass substrates, respectively. As we can see from the dry-out patterns, nanofluid droplet on glass substrate leaves a ring-shaped

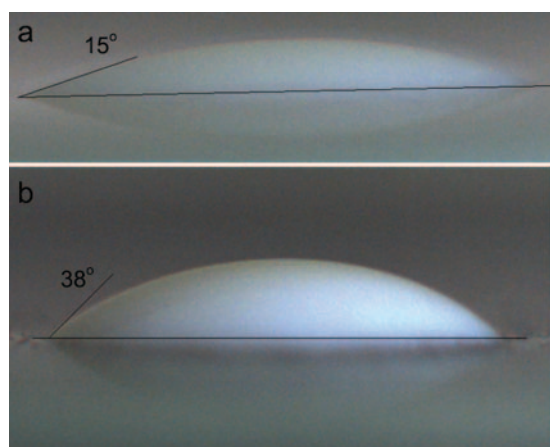

Fig. 3. (a) is the image of a stable nanofluid droplet on glass substrate. (b) shows the image of a stable nanofluid droplet on graphene coated glass substrate. Contact angles are also mentioned in the panels.

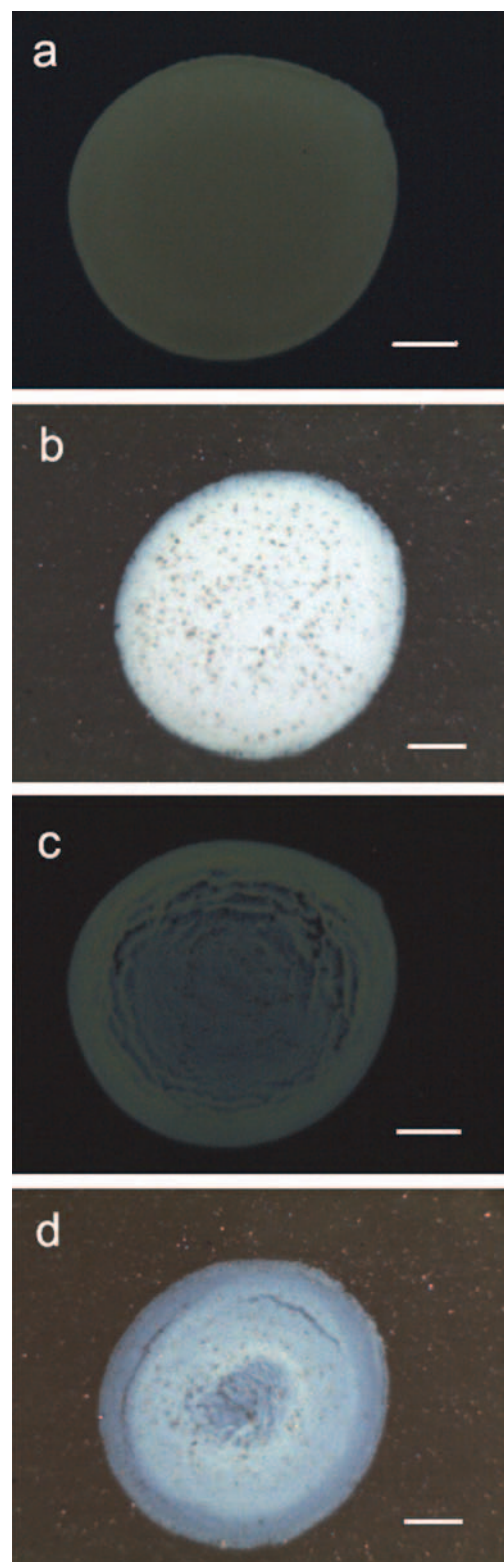

Fig. 4. (a) An image of a stable nanofluid droplet on glass substrate. (b) An image of a stable nanofluid droplet on graphene coated glass substrate. (c) An image of a dry-out pattern of nanofluid droplet on glass substrate. (d) An image of a dry-out pattern of nanofluid droplet on graphene coated glass substrate. Images (c) and (d) were taken after complete evaporation of droplets. Scale bare of 1 mm length are shown at bottom right corner in every image.

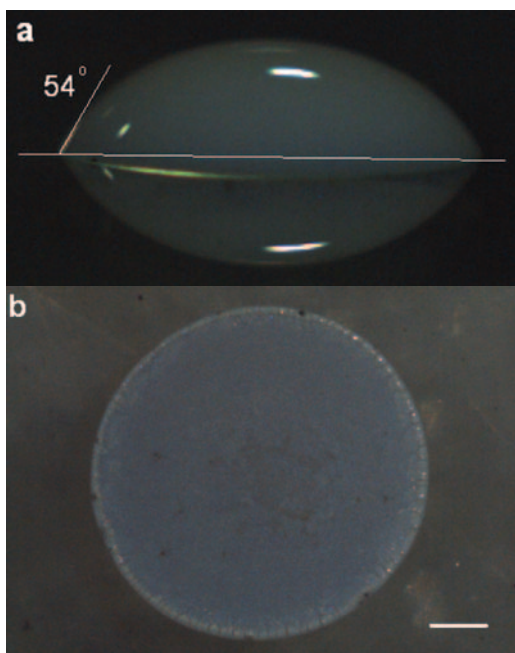

Fig. 5. (a) An image of a stable nanofluid droplet shows on sol-gel coated glass substrate. Contact angles are also mentioned in the panels. (b) An image of a dry-out pattern of nanofluid droplet on sol-gel coated glass substrate. Scale bar of 1 mm length are shown at bottom right corner in this image.

stain of concentrated nanoparticles. This happens because circular boundary of droplet remained pinned to glass surface during boiling. This can be explained by strong wetting of nanofluid to bare glass compare to graphene coated glass. During the boiling of nanofluid's droplet, nano particles have a tendency to concentrate at its outer boundary through diffusion and thermophoresis.^{13–15} Therefore, the concentration of nano particles increases at the boundary. As it is observed earlier, wettability of nanofluid increases with increase in nano particle concentration.^{16–18} So as the temperature increases nanofluid boundary is more pinned to glass surface. Moreover, as boiling proceeds due to evaporation of liquid, concentration of nanoparticle in the droplet increases which further improves wetting and pinning. While in the case graphene this pinning is relatively weak.

We have repeated the aforementioned experiments on sol-gel coated glass substrate which further reduces wettability of nanofluid. Sol-gel coating (hydrolysis followed by condensations) contains precursors, 3-glycidioxypropyltrimethoxysilane (GPTMS) at 5% concentration and tetraethyl orthosilicate (TEOS) at 5% concentrations. These two precursors are stirred in acidified deionized water for 20 hours. After adding GPTS and TEOS in the acidic media, their alkoxy group is hydrolyzed and then condensation happens between precursors. The final product contains Si–O–Si linkage which adheres to OH group of glass substrate. After coating, glass substrate is dried at

110° C for 10 minutes which evaporates water and three dimensional network of sol gel remains behind in the coating. Sol-gel coating of glass gives contact angle of 54° with 1% TiO₂ nanofluid droplets as shown in Figure 5(a). As it is evident that wetting of nanofluid droplet is poorer to sol-gel coated glass in comparison to graphene coated glass substrate, dry-out pattern of nanofluid on sol-gel coated glass substrate gives a uniform pattern as shown in Figure 5(b).

4. CONCLUSION

In conclusion, we have tried to understand the effect of variation in surface energy of heating surface on the evaporation and dry-out characteristics of TiO₂ nanofluid droplets. Surface energy of glass substrate has been altered by graphene coating. We have found that during boiling on glass substrate, boundary of nanofluid droplet recedes slowly towards the center leaving a ring-shaped stain of concentrated nanoparticles. While dry-out pattern of nanoparticles on the graphene coated glass substrate is almost uniform. We explain this behavior by reduced wettability of nanofluid droplet on graphene coated glass substrate.

Acknowledgments: The authors would like to thank staff of corrosion lab for helping us during experiments.

References and Notes

1. M. K. Chaudhury, *Nature* 423, 131 (2003).
2. S. U. S. Choi, Z. G. Zhang, W. Yu, F. E. Lockwood, and E. A. Grulke, *Appl. Phys. Lett.* 79, 2252 (2001).
3. K. Hyungdae, *Nanoscale Research Letters* 6, 415 (2011).
4. N. Prabhat, J. Buongiorno, and L.-W. Hu, *J. Nanofluids* 1, 55 (2012).
5. J. C. Maxwell and Garnett, *Philos. Trans. R. Soc. Lond. A* 203, 385 (1904).
6. R. L. Hamilton and O. K. Crosser, *Ind. Eng. Chem. Fundam.* 1, 187 (1962).
7. T. W. Darsh and A. D. Nikolov, *Nature* 423, 156 (2003).
8. C. C. Hee, S. Paik, J. B. Tipton, Jr, and K. D. Kihm, *Langmuir* 23, 2953 (2007).
9. R. Chen, T. X. Phuoc, and D. Martello, *Int. J. Heat Mass Transfer* 53, 3677 (2010).
10. S. K. Choudhary and S. Das, *J. Nanofluids* 1, 196 (2012).
11. W. Hummers and R. Offeman, *J. Am. Chem. Soc.* 80, 1339 (1958).
12. V. H. Pham, H. D. Pham, T. T. Dang, S. H. Hur, E. J. Kim, and B. S. Kong, et al., *J. Mater. Chem.* 22, 10530 (2012).
13. S. M. S. Murshed and C. A. N. D. Castro, *J. Nanofluids* 1, 180 (2012).
14. S. M. S. Murshed, C. A. N. D. Castro, and M. J. V. Lourenco, *J. Nanofluids* 1, 175 (2012).
15. C. H. Li, P. Jiang, and G. P. Peterson, *J. Nanofluids* 2, 20 (2013).
16. S. J. Kim, I. C. Bang, J. Buongiorno, and L. W. Hu, *Appl. Phys. Lett.* 89, 153107 (2006).
17. J. S. Coursey and J. Kim, *Int. J. Heat Fluid Flow* 29, 1577 (2008).
18. Kumari Mahesh and Gorla Rama Subba Reddy, *J. Nanofluids* 1, 166 (2012).