

# Optical Designs for a Multi-Beam 340 and 625/640 GHz Spaceborne Climate Research Instrument

A. Hammar<sup>1,2,\*</sup>, A. Emrich<sup>1</sup>, D. McCarthy<sup>3</sup>, A. Murphy<sup>3</sup>, N. Trappe<sup>3</sup> and J. Stake<sup>2</sup>

<sup>1</sup>*Omnisys Instruments AB, August Barks gata 6B, SE-42132 Västra Frölunda, Sweden*

<sup>2</sup>*Terahertz and Millimetre Wave Laboratory, Department of Microtechnology and Nanoscience – MC2, Chalmers University of Technology, Göteborg, Sweden*

<sup>3</sup>*Department of Experimental Physics, National University of Ireland, Maynooth, Co. Kildare, Ireland*

\*Contact: [arvid.hammar@omnisys.se](mailto:arvid.hammar@omnisys.se), phone +46-72-207 2739

**Abstract**— We report on an ongoing study where different optical configurations for a multi-beam limb-viewing (four to eight receiver channels at 340 and two channels at 625 GHz) spaceborne instrument for climate research are presented and compared. The optical configurations are analyzed in terms of optical performance (gain, side lobe levels, beam efficiency etc.), weight and size of the overall instrument envelope. Using ideal fundamental Gaussian beam modes and numerical tools relying on ray-tracing and physical optics methods, the different configurations are designed and evaluated. Preliminary results indicate that a  $1.3 \text{ m} \times 0.65 \text{ m}$  primary reflector can be used in a configuration that includes a relay optics system having two to four elements. In addition to the limb-viewing instrument, there will be an additional instrument operating at 640 GHz for observing clouds in nadir mode.

## I. INTRODUCTION

Understanding how the chemical processes in the upper troposphere/lower stratosphere (altitudes  $\sim 5\text{-}22 \text{ km}$ ) influence the Earth's climate is of high interest in climate research of today. Accurate modelling of the atmosphere relies on empirical data that can reveal the distribution of important trace gases such as  $\text{O}_3$ ,  $\text{H}_2\text{O}$ ,  $\text{CO}$  and  $\text{HNO}_3$ . Instruments operating in the THz regime are particularly well suited for making such measurements due to the many spectral lines existing at these frequencies. Spaceborne instruments like MLS [1], MAS [2], Odin [3] and SMILES [4] are all examples of single-beam limb viewers that have been used for this purpose.

By increasing the number of beams that are simultaneously used to observe the atmosphere, the spatial and temporal resolution can be significantly increased. The proposed Swedish climate research instrument STEAMR [5] is an example of a 14-beam limb viewer operating at 340 GHz, which can provide climate researchers with input data for making a three-dimensional tomographical reconstruction of the atmosphere. PREMIER was one of three candidates for ESA's seventh Earth explorer program [6] which offered a platform with relatively good spatial and power capabilities. The current aim is to develop a modified instrument that is optimized with respect to mass, size and power requirements

to be compatible with a smaller platform. The overall size - and therefore mass - of a radiometer with a highly directive antenna is largely determined by its optical system, and hence this study aims to compare different optical configurations to drive down the costs while still fulfilling the scientific goals.

## II. PREREQUISITES AND DESIGN METHODOLOGY

Some major changes have been decided for the new instrument concept. One of the most significant is to decrease the number of receiver channels to minimize the LO power requirements for the Schottky mixer receivers [7]. This also has a direct impact on the focal plane which becomes smaller. Having fewer receivers implies that the atmospheric scene that can be imaged simultaneously decreases. By letting the instrument wobble while in orbit, the optical beams corresponding to each receiver will be swept up and down in altitude to cover the atmospheric region of interest. Thus, all channels will have a shorter integration time, which sets a higher demand on low intrinsic noise in the receiver chains.

In order to obtain a smaller overall instrument envelope, the size of the primary reflector was decreased while keeping its 1:2 aspect ratio. Doing so will unavoidably decrease the antenna gain and hence the size of the full width half maximum (FWHM) beam contour on the plane in the limb which is imaged. However, this problem is overcome by choosing a lower altitude orbit ( $\sim 600 \text{ km}$ ).

To perform the three-dimensional tomography of the atmosphere, the PREMIER mission utilized a combination of a microwave multi-beam limb viewer (STEAMR) and an additional limb viewing instrument for detecting signals in the infrared region. The new concept will not have the additional instrument for infrared radiation, but will instead rely on a high frequency detector ( $\sim 625 \text{ GHz}$ ) coupled to a 150 mm aperture that moves continuously to sweep its corresponding beam in order to cover a certain portion of the ground. This concept is believed to make the instrument capable of providing the input data necessary for the atmospheric tomography.

Besides having good imaging properties, the optics of the instrument should also encompass a sub-system for calibration

of the receiver chains. Such a system will include one or several reflectors that cross the optical path to redirect the beams towards different black body loads of known temperature. The choice of optical layout must be made with this in mind.

Optical requirements (side lobe levels, beam efficiency etc.) of the new mission are essentially the same as for STEAMR [8], except for the beam distribution on the sky. To design and evaluate the different optical systems against these criteria, several design methods were employed. Having a large primary aperture in terms of wavelengths, a wide field off-axis telescope (primary and sub reflector) corrected for third order coma and spherical aberration could be designed using software for ray-tracing (Zemax [9]). Assuming a high coupling to the fundamental Gaussian beam mode, first-order models including sets of inter-reflector distances and focal lengths for the relay optics could be obtained. Finally, by using an ideal Gaussian distribution as a source, the complete optical models could be implemented into GRASP [10], where the far field beam patterns were calculated using physical optics and physical theory of diffraction.

### III. OPTICAL CONFIGURATIONS

As for the STEAMR instrument for the PREMIER mission, cf. Fig. 2, the edge taper of the primary reflector is 25 dB which was chosen to suppress side lobes rather than maximizing the aperture efficiency.

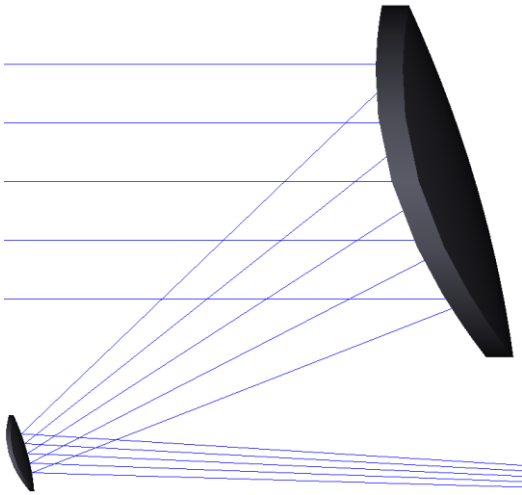

Fig. 1 Off-axis  $f/10$  Cassegrain telescope corrected for coma and spherical aberration. The primary aperture is  $1.3 \text{ m} \times 0.65 \text{ m}$ .

The FWHM  $\theta_{FWHM}$  (in radians) of the main beam from a Gaussian illuminated primary reflector of diameter  $D$  and edge taper  $T_e$  is given by [11]

$$\theta_{FWHM} = (1.02 + 0.0135 \cdot T_e) \frac{\lambda}{D}, \quad (1)$$

where  $\lambda$  denotes the wavelength. Using an orbit of altitude  $\sim 600 \text{ km}$  instead of the proposed  $820 \text{ km}$  orbit of PREMIER, the required beam FWHM is relaxed and a  $1.3 \text{ m}$  aperture is sufficient to achieve the needed vertical resolution.

Figure 1 shows an example of a telescope that was used for some configurations in the study. It is an off-axis

Cassegrain-type telescope that was designed using ray-tracing methods to optimize the performance over a wide field of view.

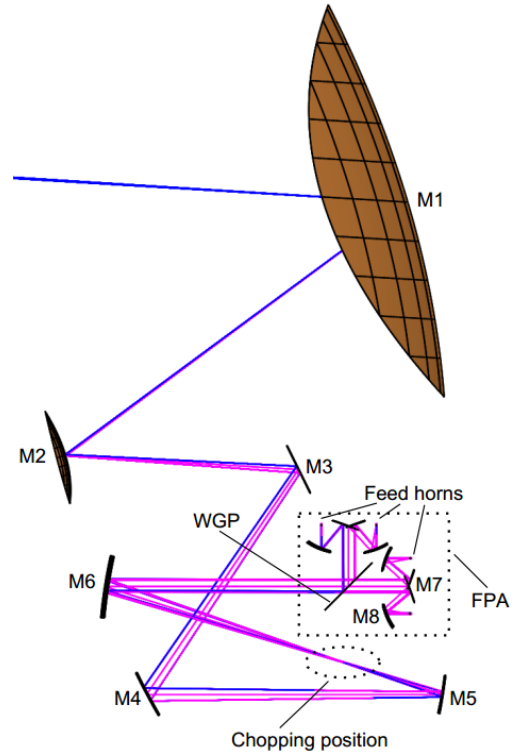

Fig. 2 GRASP CAD model of the optical chain of the PREMIER version of STEAMR [12]. The primary aperture is  $1.6 \text{ m} \times 0.8 \text{ m}$ .

#### A. Concept 1: Six-reflector system

The STEAMR instrument developed for the PREMIER mission had an optical system consisting of six off-axis reflectors and two focal plane arrays, each comprising two sets

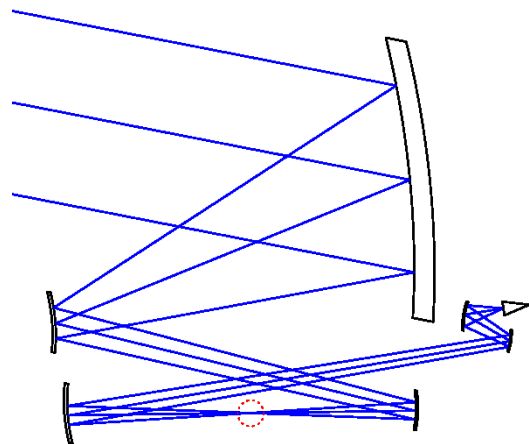

Fig. 3 Sketch of a six-reflector concept. The location where the beams are to be re-directed towards the calibration loads is indicated with a dashed red circle. The triangle indicates a feed horn.

of faceted reflector surfaces for seven beams, which were separated in polarization using a wire grid polarizer, cf. Fig. 2.

This version of the optical system (cf. Fig. 3) is an attempt to essentially maintain all functionality of the instrument

developed for PREMIER, but with a reduced number of reflectors and a more easily accessible location to redirect the beams towards thermal loads using a chopping mirror.

As the number of receivers is believed to vary between four and eight, a single focal plane will be sufficient. Even though the number of reflectors is reduced by two compared to the PREMIER version of the instrument, it will still have enough degrees of freedom to make the beams at the aperture having a matching taper (elliptical, 1:2 aspect ratio) and having a multiple of  $\pi$  Gouy phase shift from the feed horns to achieve frequency independent illumination [13].

The receiver chains have been placed behind the primary aperture. Besides being a position that does not add much to the physical envelope, it is also convenient since excess heat from dissipated in the LO chains can radiate into free space.

### B. Concept 2: Four to five-reflector system

Removing one or two of the reflectors compared to the concept 1 presented above may result in a system as the one shown in Fig. 4. The receivers are positioned behind the primary reflector to ease the implementation of an efficient heat dissipation system. The sketch shown in Fig. 4 has an off-axis Cassegrainian telescope with a convenient position for a calibration chopper mirror between the telescope sub reflector and first relay optics reflector. One option is to use a Gregorian telescope to make the instrument more compact in the vertical direction, cf. Fig. 4. However, for a given  $f/D$  of the telescope, a Gregorian design implies a larger instrument envelope in the horizontal direction.

One important consequence of removing one or two reflectors is that the degrees of freedom decrease. Since high resolution in the elevation direction is prioritized, the rim of the primary reflector is elliptical. By employing a number of astigmatic reflectors in the relay optics ( $\geq 2$ ), the beams can be properly shaped to match the primary aperture and having a Gouy phase shift that ensures frequency independent operation. With four to five reflectors these criteria become difficult to fulfil.

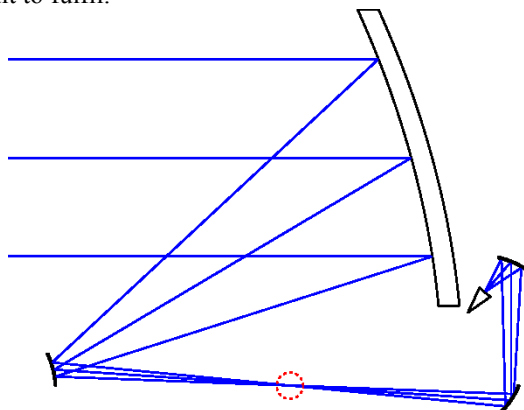

Fig. 4 Sketch of a four reflector concept. The location where the beams are to be re-directed towards the calibration loads is indicated with a dashed red circle. The triangle indicates a feed horn.

However, since the main priority is to have a good resolution in the elevation direction, one possibility is to simply accept different edge tapers when illuminating the primary aperture. This will of course give rise to side lobes in

the azimuth direction, but this may be accepted as long as the resolution in the elevation direction is maintained. Complying the requirement for frequency independence may still be possible.

### C. Concept 3: Three-reflector system

Since the system needs to have a mechanism for steering the beams towards the on board black body calibration loads, a direct illumination of the sub reflector by the feed horns is not a feasible solution. Instead, the absolute minimum number of reflectors is three.

Although being lightweight due to the removal of other reflectors, the possibility of a correct primary reflector illumination and frequency independent operation will no longer be possible.

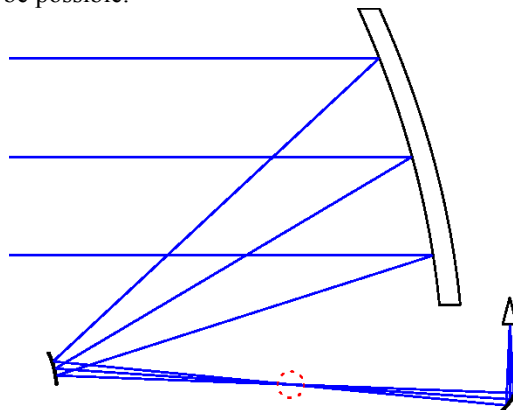

Fig. 5 Sketch of a three reflector concept. The location where the beams are to be re-directed towards the calibration loads is indicated with a dashed red circle. The triangle indicates a feed horn.

## IV. CALIBRATION SYSTEM AND NADIR INSTRUMENT

As mentioned in previous sections, there is a need for an optical sub-system to steer the beams from the feed horns towards black body loads at different temperatures. Regardless of which implementation of the optical chain is chosen, the design must be made with the implementation of the calibration system in mind.

On board the platform will be two black body loads at different temperature. Besides these loads, the beams will also be steered towards cold space (and possibly, against a CW source). The number of moving parts has to be minimized and this has a direct impact on the choice of chopping mirror. The two candidates that have been considered are of a spinning wheel type similar to the one used on Odin [3] and a spinning cuboid with two facing sides open.

As mentioned in section I, the instrument will employ an additional channel at 640 GHz for observing the clouds in nadir mode. The beam footprint on the ground (5-15 km) of this channel will move in a cross-track pattern while in orbit. As for the main optical system, there is also a need for a calibration system for the 640 GHz channel with corresponding black body loads. One option here is to make use of the existing loads for the limb-viewing system.

## V. CONCLUSION AND OUTLOOK

An investigation to find out which optical configuration is the most optimal to meet the given scientific requirements,

given a stricter budget in terms of mass, size and power requirements, is ongoing. Well-established methods are being used to investigate optical performance. Concurrent engineering between optical design and mechanical implementation ensures that realistic assumptions on the mass of the reflectors and the corresponding support structures can be made.

#### ACKNOWLEDGMENT

This work was supported in part by the Swedish research council (VR) under contract no. 2010-4040.

#### REFERENCES

- [1] J. Waters and G. Peckham, "The microwave limb sounder (MLS) experiments for UARS and EOS," in Geoscience and Remote Sensing Symposium, 1991. IGARSS '91. Remote Sensing: Global Monitoring for Earth Management., International, vol. 2, Jun 1991, pp. 543–546.
- [2] C. Croskey et al., "The Millimeter Wave Atmospheric Sounder (MAS): a shuttle-based remote sensing experiment," IEEE Transactions on Microwave Theory and Techniques, vol. 40, no. 6, pp. 1090–1100, Jun 1992.
- [3] U. Frisk et al., "The Odin satellite. I. Radiometer design and test," Astronomy and Astrophysics, vol. 402, pp. L27–L34, May 2003.
- [4] Y. Kasai, J. Urban, C. Takahashi, S. Hoshino, K. Takahashi, J. Inatani, M. Shiotani, and H. Masuko, "Stratospheric ozone isotope enrichment studied by submillimeter wave heterodyne radiometry: the observation capabilities of SMILES," IEEE Transactions on Geoscience and Remote Sensing, vol. 44, no. 3, pp. 676–693, March 2006.
- [5] B. Carnicero Dominguez et al., "ESA's premier mission candidate: System and payload overview," in Geoscience and Remote Sensing Symposium (IGARSS), 2012 IEEE
- [6] "ESA website." [Online]. Available: [http://www.esa.int/Our\\_Activities/Observing\\_the\\_Earth/Earth\\_Exploration\\_overview](http://www.esa.int/Our_Activities/Observing_the_Earth/Earth_Exploration_overview)
- [7] P. Sobis, A. Emrich, and J. Stake, "A low VSWR 2SB schottky receiver," IEEE Transactions on Terahertz Science and Technology, vol. 1, no. 2, pp. 403–411, Nov 2011.
- [8] A. Hammar et al., "Optical Tolerance Analysis of the Multi-Beam Limb Viewing Instrument STEAMR", IEEE Transactions on Terahertz Science and Technology, vol. 4, no. 6, pp. 714–721, Nov 2014.
- [9] Radiant Zemax website. [Online]. Available: <http://www.radiantzemax.com/en>
- [10] TICRA website. [Online]. Available: <http://www.ticra.com/products/software/grasp>
- [11] P. Goldsmith, Quasioptical Systems: Gaussian Beam Quasioptical Propagation and Applications, ser. IEEE Press Series on RF and Microwave Technology. Wiley, 1998.
- [12] A. Hammar, "Optical Analysis and Characterisation of the Climate Research Instrument STEAMR", licentiate of engineering thesis, Nov. 2014.
- [13] M. Whale, A. Murphy, A. Murk, M. Renker, U. Frisk, and O. Janson, "A Compensating Anastigmatic Submillimeter Array Imaging System for STEAMR," IEEE Transactions on Terahertz Science and Technology, vol. 3, no. 1, pp. 110–119, 2013.
- [14] Wireless LAN Medium Access Control (MAC) and Physical Layer (PHY) Specification, IEEE Std. 802.11, 1997