

380 MHz Low-Power Sharp-Rejection Active-RC LPF for IEEE 802.15.4a UWB WPAN

Anh Tuan Phan, and Ronan Farrell
Institute of Microelectronics and Wireless Systems,
National University of Ireland, Maynooth, Ireland.

Jeongseon Lee, Sang-Gug Lee
RFIC Lab, Information and Communications University
(ICU), Daejeon, Korea

Abstract— This paper describes a wide-band sharp-rejection active-RC low pass filter (LPF) for pulse-based UWB IEEE 802.15.4a WPAN applications. Sharp rejection is attributed to the combination of different AC characteristic of three biquads in series. A simple operational amplifier (Op-amp) is adopted to ensure high frequency performance for the designed filter. The LPF is designed in 0.13 μm TSMC CMOS process. The cutoff frequency is 380MHz with about 50% of the tuning range from 300-500MHz. The rejection is 40 dB at 600 MHz. The passband ripple is less than 1.5dB and the filter consumes 4.6mA from 1.2V supply. Core chip size is 580 x 700 μm^2 .

I. INTRODUCTION

IEEE 802.15.4a standard has recently adopted UWB as physical layer, which is capable of providing accurate ranging and positioning [1]. The goal of this low data rate (LDR) wireless personal area network (WPAN) networks standard is to provide joint communications and high accuracy positioning in future sensor networks. Short pulses with the channel bandwidth of 499.2 MHz are transmitted allowing ranging accuracy of 1 meter [2]. 802.15.4a supports three bands of operation, sub-1GHz band, low band (3.1-4.8GHz), and high band (6-10.6GHz) with 16 channels in total. Fig. 1(a) shows the frequency planning of three subbands in the low band.

LPF is a key building block in the transmission system, mostly designed for channel selection and anti-alias. In 802.15.4a UWB, the whole spectrum is divided into several sub-channels [2], each of these channels can easily cause the interference on its both side adjacent ones or in an opposite way, the accumulated interferences from other channels can overlap on one given channel. Because of that severe inherent characteristics of subbanded UWB, high performance LPF is needed.

The LPF is required to have high rejection ratio, so that it can suppress the interference from adjacent channels. More over, it should have high linearity and wide bandwidth to meet the requirement of UWB. Fig 1(b) shows the required specification for the UWB LPF based on the system analysis. 802.15.4a also poses challenges for low-power dissipation and low-cost design.

Recently published LPF for UWB show high frequency characteristics, however, the attenuation ratio is moderate with large power consumption [3]-[4]. For wideband LPF, Gm-C LPF is often used but it is limited in linearity, dynamic range and sensitive to parasitic [5]. Previous published works of active RC LPF are often for narrow band

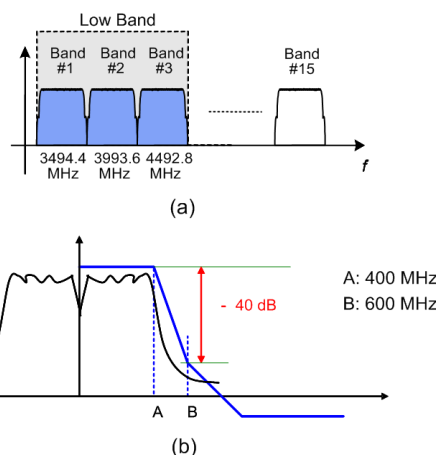

Figure 1. Impulse UWB channel selection requirement for LPF

applications, most papers show the cutoff frequency in the range of a hundred MHz are gm-C type [6]-[9].

In active-RC LPF, the tradeoff between high frequency characteristic and the cost of high power consumption always poses a challenge for designers. Active-RC or Op-amp based LPF has better linearity, dynamic range. With a new structure of Op-amp, the cutoff frequency can be extended to satisfy the UWB bandwidth requirement and take advantages of opamp-RC LPF.

In this paper, a wide-band, high linearity Op-amp RC LPF for impulse UWB with sharp rejection is presented. A special technique to increase the roll-off of the filter is proposed. A simple Op-amp is used to ensure high frequency performance of the designed filter with low current consumption. Digital tuning is adopted to deal with process variation. The filter is designed in 0.13 μm TSMC CMOS process. A proposed filter, among the first few of its type, has very good performance, proven itself suitable for wideband applications like UWB.

II. LPF DESIGN

Each impulse UWB channel is 499.2 MHz wide according to IEEE 802.15.4a, thus the ADC needs to sample at Nyquist frequency, which is about 1 GHz. For anti-aliasing, the cutoff frequency of LPF is chosen around 400MHz from system simulation and prototype experiment. For this high cutoff frequency, most of the data information is transmitted and received, thus the SNR is improved.

As aforementioned, the LPF is required to have very high rejection ratio. Rejection ratio or attenuation ratio is defined

as the different level of signal in the pass-band compared to that at a given frequency. In this design, the frequency of concern for rejection is at 600 MHz. High linearity feature is also demanded, hence, out of band interferences do not create inter-modulation which fall in the pass-band.

The order of the filter is determined based on the type of filter, cutoff frequency and signal attenuation ratio requirement. Classical configurations are Bessel, Chebyshev, Elliptical and Butterworth filters. Among them, Butterworth give the high rejection ratio with the same order while requires a reasonable Q factor.

A. Topology Selection

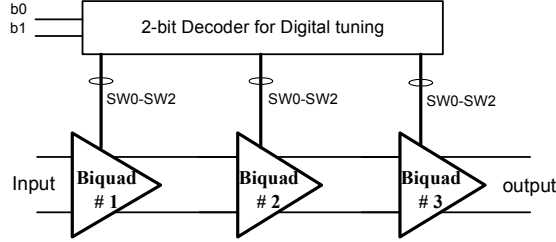

Figure 2. Block diagram of the 6th order RC LPF

To achieve high attenuation ratio as required in Fig. 1(b), the number of order for Butterworth LPF (n_{Bu}) calculated from (1) should be larger than 12 based on the theory analysis in [10], which leads to a very complex, large chip size and high power circuit.

$$n_{Bu} = \frac{\log\left[\frac{(10^{0.1\alpha_{min}} - 1)}{(10^{0.1\alpha_{max}} - 1)}\right]}{2 \log(\omega_s / \omega_p)} \quad (1)$$

where ω_s and ω_p is the stop-band and pass-band frequency, α_{min} is the ripple at the pass-band and α_{max} is the attenuation at the stop-band. Because of that, 6th order LPF topology is chosen as a compromise of those constraints. The whole structure of 6th order LPF is shown in Fig. 2 with three Biquad stages. In order to satisfy the attenuation ratio with low order filter, a new technique is proposed which employs the steep slope at the peaking point of a Biquad.

B. Proposed Sharp Rejection Technique

Shown in Fig. 3 are the three different AC characteristics of the three Biquads to demonstrate the proposed technique. Each Biquad has the peaking at different frequencies. When cascading them, the frequency responses are combined. At the cut-off frequency, sharpest slope is obtained while at other frequencies in the pass-band, flat AC response is achieved.

From Fig. 3, Biquad 1 has highest peaking or Q-factor near the cutoff frequency (at 385 MHz), leading to a sharp slope. Biquad 2 has high attenuation at the cutoff frequency to compensate with the frequency response of Biquad 1. Hence, Biquad 3 should have moderate peaking at lower frequencies (at 250 MHz) to compensate with the attenuation of Biquad 1 at these low frequencies. As a result, when the three frequency responses of Biquads are combined, very sharp attenuation is achieved at the corner frequency and the flat frequency response in the whole bandwidth.

The proper arrangement of three Biquads also helps reduce the noise figure (NF) and linearity. Because the NF

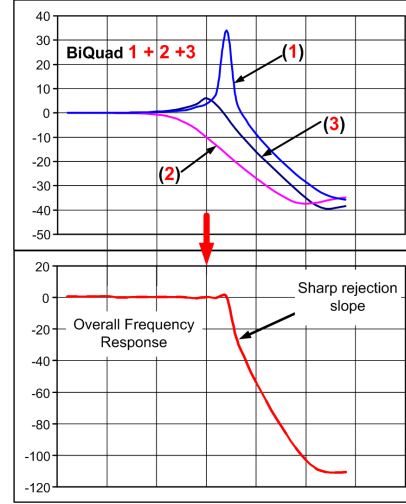

Figure 3. Three different AC characteristic of the three Biquads.

depends mostly on the first stage, thus, the first stage should have higher gain or highest peaking but linearity is trade-off.

C. Biquad

A Biquad is shown in Fig. 4 equivalent to a 2nd order LPF. It consists of two Op-amp and other passive components R and C. The transfer function of the Biquad is presented as in (2).

$$T(s) = \frac{-1/R_1 R_3 C_1 C_2}{s^2 + (1/R_2 C_2)s + 1/R_2 R_3 C_1 C_2} \quad (2)$$

From (2), the cut-off frequency (ω_{cutoff}), Q factor and gain (H) of the Biquad are determined by R and C values as

$$\omega_{cutoff} = \frac{1}{R_2 R_3 C_1 C_2}, \quad Q = \sqrt{\frac{R_4^2 C_2}{R_2 R_3 C_1}}, \quad \text{and} \quad H = \frac{R_2}{R_1} \quad (3)$$

C2 will be used to adjust the peaking or Q-factor of the Biquad since other components relating to other specifications are fixed. By changing the values of the passive components, the desired AC characteristics are obtained for each Biquad.

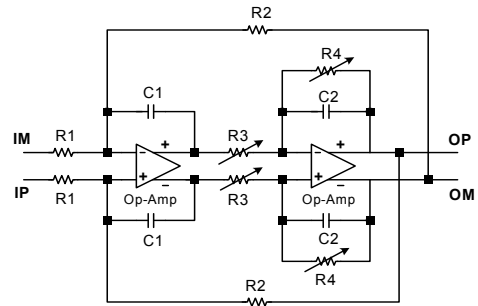

Figure 4. 2nd order Biquad structure with key tuning components

D. Op-Amp

Operational amplifier (Op-amp) is the core circuit in designing the RC LPF. It will determine the frequency characteristics, linearity and voltage swing of the whole LPF. In order to have high frequency performance, a simple Op-amp is used in this design, shown in Fig. 5.

The Op-amp has two stages, transconductance stage and the output buffer. The buffer stage has the unit gain and its main function is for the output impedance matching. Diode connected PMOS transistors are used as the load of the Op-amp, the gain of the Op-amp without PMOS cross connection is represented as

$$A_v = \frac{g_m \times R_L}{1 + g_m \times R_{\text{degeneration}}} \quad (4)$$

where $R_L = 1/g_{mp}$, g_m and g_{mp} are the transconductance of transistor $M_{3,4}$ and $M_{7,8}$, respectively.

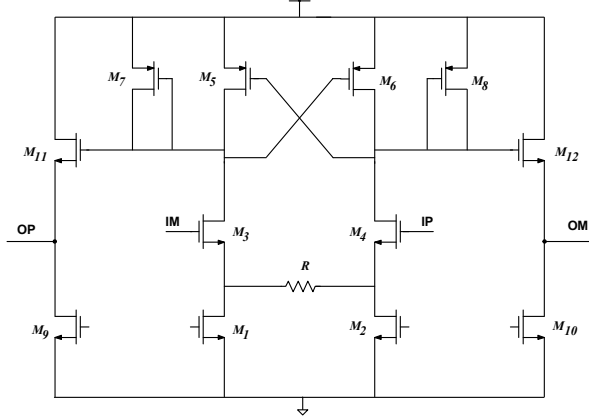

Figure 5. Proposed simple Op-Amp topology

Due to the tradeoff between the current consumption and gain, to have high gain with a given limited amount of current, a cross connection at the PMOS load transistors $M_{5,6}$ is adopted. This cross connection creates the negative transconductance ($-g_{mc}$) which compensate positive g_{mp} of the diode connected PMOS and g_{ds} of $M_{3,4}$. Thus the total transconductance at the load is reduced leading to the improvement of the gain as specified in due to the increase of R_L (5).

$$R_L = \frac{1}{G_{\text{total}}} = \frac{1}{g_{m7} - g_{m6} + g_{ds3} + g_{ds4} + g_{ds5}} \quad (5)$$

From (7), when $g_{mp7,8}$ and $g_{mc5,6}$ are designed with close values, R_L can be significantly increased and so is the gain. Another advantage of the op-amp shown in Fig. 5 is self-biasing. No current reference or common mode feedback is required for the load avoiding additional power dissipation

The Op-amp has two poles, the dominant one is at the output node and the other one is at the drain of PMOS load transistors. Those transistor sizes are selected with small channel length to put the pole far away from the dominant one. Thus, the Op-amp has very high frequency characteristic. Degeneration resistor R is used to increase the linearity of the Op-amp as well as of overall LPF.

E. Tuning circuitry

An important feature in practical continuous time filter design is the corner frequency variation due to process variation, temperature and voltage. The corner frequency is set by the absolute values of R and C components. However, those values can vary as much as 25 %.

In order to deal with corner frequency variation, in this design, a digital tuning circuit is adopted. From the transfer

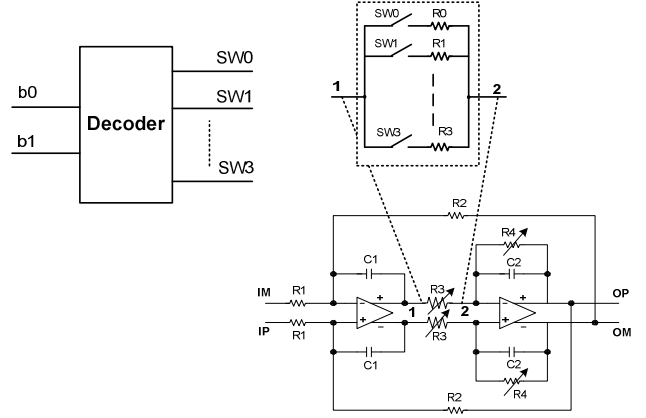

Figure 6. Frequency and Q-factor digital tuning circuit diagram

function of the Biquad (2), by varying the value of resistor R3, the corner frequency can be changed as in (3). We do not choose the capacitor value tuning because the value of capacitor is small and close to the parasitic value and very sensitive to process variation, thus, the tuning is not accurate.

Two control bits are used at the input resulting 4 frequency steps at the output. An array of 4 different value resistors from $R0 \div R3$ is implemented at the position of R3 in each Biquad. The output of the decoder will turn on the switch, $SW0 \div SW3$, as a result, the value of the resistor is selected corresponding to the input bit combination. The digital tuning block is shown in Fig. 6.

During the cut-off frequency tuning, the peaking or Q-factor is varied, leading to the high ripple near the corner frequency. To flatten the AC response, Q-tuning is realized simultaneously with the corner frequency tuning. In Fig. 6, by changing the value of R4, Q factor is varied resulting to a flat AC response along overall LPF pass-band.

III. SIMULATION RESULTS

The UWB LPF is designed using 0.13 um TSMC CMOS technology in Cadence with the voltage supply of 1.2V.

A. LPF AC Characteristic

The AC characteristic of the designed LPF is shown in Fig. 7. The cut-off frequency at 3 dB is 380 MHz.

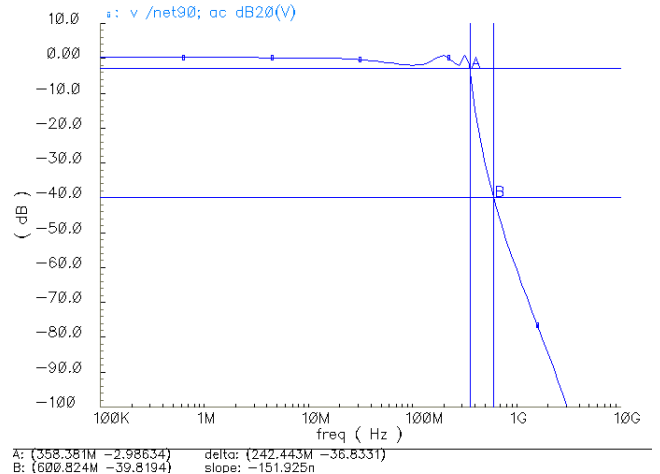

Figure 7. Single AC characteristic of the LPF with sharp slope

To meet the strict requirement of out-of-band attenuation, the corner frequency is adjusted to 380MHz instead of 400MHz. As a result, the attenuation is 40 dB at 600 MHz. This filter has very sharp slope at the cutoff frequency compared to other filters designed in conventional way by cascading a number of small order filter stages. The pass-band ripple is less than 1.5 dB. Almost constant group delay is also achieved along the pass-band except a high value near the corner frequency.

Two control bits results in the tuning range of about 50% from 300MHz to 500MHz with 4 frequency steps, post-simulation results are shown in Fig. 8.

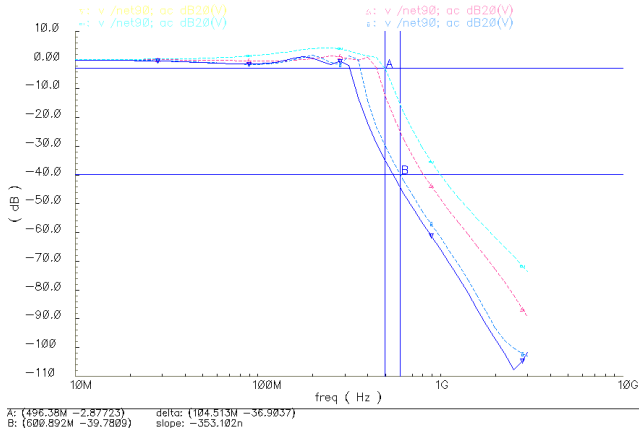

Figure 8. AC tuning characteristic of the LPF from 300 to 500MHz

The average NF is about 18dB in pass-band and increases outside the corner frequency. Two-tone test shows 0dBm of IIP3. The total current consumption of the LPF is 4.6 mA at 1.2V supply. Digital tuning circuit consumes almost no DC current. The LPF performance of this work and other high frequency ones are summarized for comparison in Table. 1. The designed LPF shows the smallest power consumption compared with other previous published LPFs for wideband applications. In Fig. 9, the layout of the designed LPF is shown, which is compact with the size of 580 x 700 μm^2 .

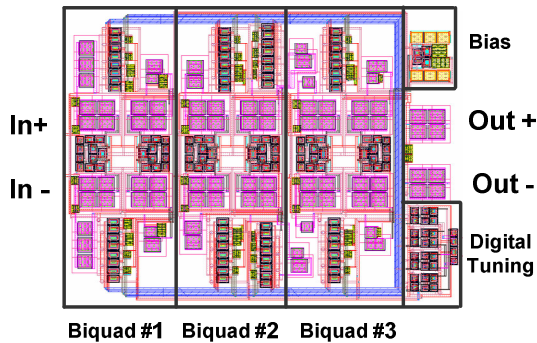

Figure 9. Layout of the designed LPF, 580 μm x 700 μm .

IV. CONCLUSION

A low-power sharp-rejection LPF for IEEE 802.15.4a UWB is presented. The circuit techniques for the bandwidth extension and sharp stop-band characteristic is proposed by superimposing the biquads with different cutoff frequencies and Q-factors. A simple Op-amp can assure wide bandwidth

TABLE I. HIGH FREQUENCY LPF PERFORMANCE COMPARISON

Parameters	[4]	[6]	[7]	[8]	[9]	This work
Technology (CMOS)	0.18 μm	0.35 μm	0.35 μm	0.25 μm	0.13 μm	0.13μm
Filter type	Elliptic	Linear Phase	Linear Phase	Eq.Rip	G _m -C	RC Butterworth
Order	6	7	4	7	5	6
Cutoff Freq. (MHz)	500	200	150	250	240	380
Supply voltage (V)	1.8	3.3	2.3	2	1.2	1.2
Power Cons. (mW)	14	60	90	216	24	5.6
Input voltage swing (mV)	-	500	200	250	-	300

of the filter with small current consumption. The cut-off frequency is 380MHz with 40dB rejection at 600MHz. The filter ripple is less than 1.5dB with almost constant group delay along the pass-band. The designed filter, among the first few designs of wideband active RC LPF, shows very good performance making it really suitable for wideband applications like UWB. The LPF is designed in 0.13 μm CMOS process from 1.2V supply. It consumes 4.6mA with total chip size of 580 x 700 μm^2 .

ACKNOWLEDGMENT

The work was supported by Korea Science and Engineering Foundation through National Research Lab, funded by Ministry of Science and Technology (No. R0A-2007-000-10050-0). Also funded by Science Foundation Ireland through Centre for Telecommunication Value-Chain Research (03/CE3/I405), under National Development Plan.

REFERENCE

- [1] IEEE 802.15.TG4a official web page: <http://www.ieee802.org/15/pub/TG4a.html>.
- [2] IEEE 802.15.4 MAC standard, 2006 revision, Available at <http://www.ieee.org/>.
- [3] J. Bergervoet et al, "An interference robust receive chain for UWB radio in SiGe BiCMOS," *ISSCC Dig. Tech. Papers*, pp. 200-202, Feb. 6-10, 2005.
- [4] Sachio lida et al, "A 3.1 to 5GHz CMOS DSSS UWB Transceiver for WPANs," *ISSCC Dig. Tech. Papers*, pp. 200-202, Feb. 6-10, 2005.
- [5] Y.P. Tsvividis, "Integrated continuous-Time filter Design-An overview," *IEEE J. Solid-state Circuits*, vol 29, no. 3, pp. 166-176, Mar. 1994.
- [6] J. Silva-Martinez et al. "A 60-mW 200-MHz continuous-time seventh-order linear phase filter with on-chip automatic tuning system," *IEEE J. Solid-State Circuits*, vol. 38, no. 2, pp. 216-225, 2003.
- [7] M. Chen et al, "A 2-V/sub pp/ 80-200-MHz fourth-order continuous-time linear phase filter with automatic frequency tuning," *IEEE J. Solid-State Circuits*, vol. 38, no. 10, pp. 1745-1749, 2003.
- [8] Masood-ul-Hasan, and Yichuang Sun, "2V 0.25 μm CMOS 250MHz Fully-differential Seventh-order Equiripple Linear Phase LF Filter," *IEEE Int. Symp. Circuits and Systems (ISCAS)*, pp. 5958 – 5961, 23-26 May 2005.
- [9] Ville Saari, Mikko Kaltiokallio, Saska Lindfors, Jussi Rynnänen, and Kari Halonen "A 1.2-V 240-MHz CMOS Continuous-Time Low-Pass Filter for a UWB Radio Receiver," *ISSCC Dig. Tech. Papers*, 2007
- [10] Rolf Schaumann and Mac E. Van Valkenburg, "Design of Analog filter", New York, Oxford Press, 2001.