

# Negative resistance generation in degenerated gyrator

Grzegorz Szczepkowski, Ronan Farrell

Center for Telecommunications Value Chain Research

Institute of Microelectronics and Wireless Systems

National University of Ireland, Maynooth, Co Kildare

Email: [gszczepkowski@eeng.nuim.ie](mailto:gszczepkowski@eeng.nuim.ie), [rfarrell@eeng.nuim.ie](mailto:rfarrell@eeng.nuim.ie)

## Abstract

In this paper the concept of a degenerated gyrator is presented. Using the proposed method, a negative resistance can be generated in a gyrator circuit using only passive components. Simulation results show that the negative resistance produced by gyrator degeneration allows stable harmonic oscillations to be obtained in an active inductor circuit without the use of any additional components.

## I. INTRODUCTION

Active inductors provide an alternative to passive counterparts, especially where circuit size and tuning range are important. One of the most interesting applications for active inductors is that of oscillators. If an active inductor could present negative resistance, a self-oscillating, harmonic circuit could be achieved. Such circuits have been presented in the past by Hayashi *et al.* [1] and Szczepkowski *et al.* [2], proving that an additional energy restorer might be removed completely from a oscillator circuit. Active inductors can be also used in filters and integrated couplers, as demonstrated by a recent paper from Hsieh *et al.* [3], where partial loss-compensation was utilized to achieve a high quality factor (Q) of a quadrature hybrid. Despite numerous publications in this area, many authors do not explain how negative resistance is achieved in a circuit, focusing only on its application with limited design guidance. This paper presents an exploration for how the proposed degeneration technique can use passive components in a gyrator circuit to generate negative resistance.

## II. DEGENERATED GYRATOR

A gyrator circuit inverts impedance thereby allowing a series resonant network to behave like a parallel structure. However as an ideal positive impedance inverter, it will exhibit a negative resistance on its input only if loaded by a negative resistance. Fig. 1a depicts proposed degenerated gyrator circuit, loaded with a passive RC network  $C_1$ ,  $R_2$  and  $C_3$ . Both voltage-controlled current sources (VCCS) have been given the same gain value  $gm$ .

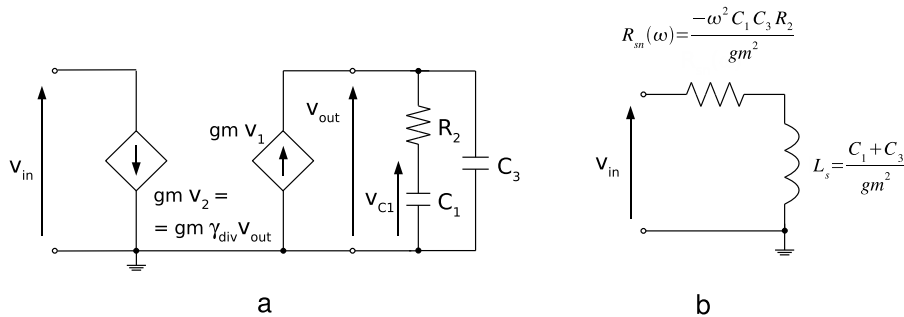

Fig. 1. (a) Degenerated gyrator circuit, (b) equivalent small signal model.

The gyrator degeneration is obtained by driving an input VCCS with a voltage  $V_2$ , that is, a proportional fraction of the total output voltage  $V_{out}$ , controlled by the ratio  $\gamma_{div}$  of the voltage divider  $C_1 R_2$ . Assuming  $C_3$  is connected at the output, a general form of the input impedance is equal to:

$$Z_{in} = \frac{1}{\gamma_{div}} \cdot \frac{-\omega^2 C_1 C_3 R_2 + j\omega (C_1 + C_3)}{gm^2 (j\omega C_1 R_2 + 1)} \quad (1)$$

In the case of no degeneration ( $\gamma_{div} = 1$ ,  $V_2 = V_{out}$ , an ideal gyrator), the negative term  $-\omega^2 C_1 C_3 R_2$  is always dominated by the positive product  $\omega^2 C_1 R_2 (C_1 + C_3)$  (1). However, if the input VCCS is controlled only by a voltage on  $C_1$  ( $V_{C1}$ , Fig. 2a), the division ratio  $\gamma_{div}$  becomes:

$$\gamma_{div} = \frac{1}{j\omega C_1 R_2 + 1} \quad (2)$$

When combined with (1), the input impedance can be derived as follows:

$$Z_{in} = \frac{-\omega^2 C_1 C_3 R_2 + j\omega (C_1 + C_3)}{gm^2} \quad (3)$$

and equivalent circuit is depicted on Fig. 1b. Equation (3) shows that degeneration technique results in the cancellation of the term responsible for the positive resistance, leaving only a negative product and an inductive reactance. The negative resistance is generated by a multiplication of two capacitive admittances of  $C_1$  and  $C_3$ , in a similar manner as the one-port Colpitts oscillator representation presented by Razavi [4]. The same equation also indicates that the generated negative resistance can approach significant values for a high signal frequency and a small transconductance, even for a relatively small capacitances  $C_1$  and  $C_3$ . This allows us to utilize gyrator parasitic capacitances and still achieve useful values of negative resistance. Furthermore, as only passive components are employed, no additional power is needed to produce negative resistance. This is especially crucial for low-power applications where a power budgets are stringent.

### III. CIRCUIT SIMULATION

To demonstrate a negative resistance generation mechanism proposed in this paper, a basic grounded active inductor with resistive feedback was chosen (Mukhopadhyay *et al.* [5]). The gyrator depicted on Fig. 2 was designed using Mentor Graphics and simulated in Eldo RF based on standard UMC 0.18  $\mu\text{m}$  CMOS process. The small signal analysis and basic circuit transformations prove that presented active inductor is, in fact, an example of the degenerated gyrator with additional parasitic components and  $gm$ -dependent losses. The gate to source capacitance  $C_{gs1}$  of  $M_1$  transistor connected in series with the feedback resistor  $R$  creates an RC voltage divider. By the definition, the transistor  $M_1$  is driven by the voltage across  $C_{gs1}$ , hence the degeneration described by (2) is obtained. The parasitic drain-gate capacitance of  $M_2$ , though small, is utilized as the second capacitance that is necessary to produce negative resistance. Equation (3) indicates that for a certain values of the signal frequency  $\omega$ ,  $R$ ,  $C_{gs1}$  and  $gm$ , even a small value of  $C_{gd2}$  generates a significant negative resistance, thus it can not be neglected. It is also important to state that other circuit parasitics (especially drain to bulk capacitances  $C_{db}$  and drain to source conductances  $g_{ds}$  of  $M_2$  and  $CS_2$  transistors) also contribute to the negative resistance generation mechanism. A detailed explanation of these effects is described in the previous work of Szczepkowski *et al.* [2].

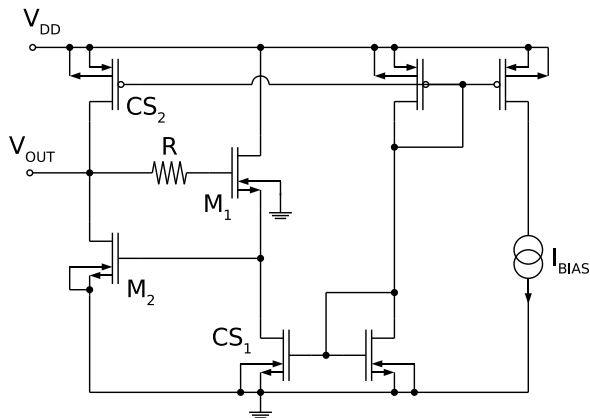

Fig. 2. Proposed self-oscillating resonant tank.

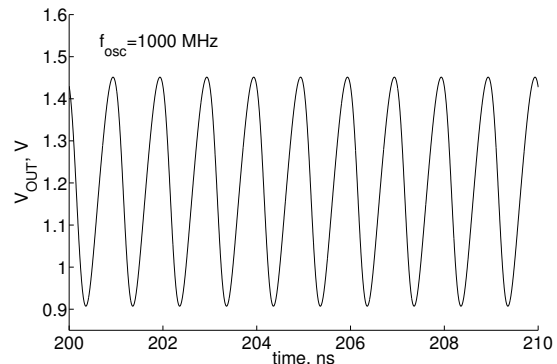

Fig. 3. Simulated output signal.

The active inductor presented in (Fig. 2), together with its parasitic capacitances and conductances may be considered as a stand-alone self-oscillating resonant tank. Fig. 3 shows an example of transient simulation of the oscillator output voltage  $V_{OUT}$ . Sinusoidal oscillations at 1000 MHz have been obtained and the circuit consumes only 2.8 mW of power with a 1.8 V supply voltage. Since a self resonance frequency of the circuit depends on the biasing current  $I_{BIAS}$ , a compact, low power current controlled oscillator (CCO) may be also achieved. In this case an overall tuning range is restricted by inductor parasitics and frequency dependent losses.

### IV. CIRCUIT IMPLEMENTATION

A layout of the prototype circuit is presented on Fig. 4. To prevent load pulling of the oscillator core, output source follower is connected. In addition a single ended architecture is designed as a quasi-differential to minimize both common node noise and process variations. The overall area occupied by the prototype (self-oscillating resonant tank, output buffer and bias circuit) is no more than 0.016  $\text{mm}^2$ , whereas the smallest passive spiral inductor available in standard UMC 0.18  $\mu\text{m}$  process occupies 0.068  $\text{mm}^2$ . The circuit is currently being fabricated by IMEC, Belgium.

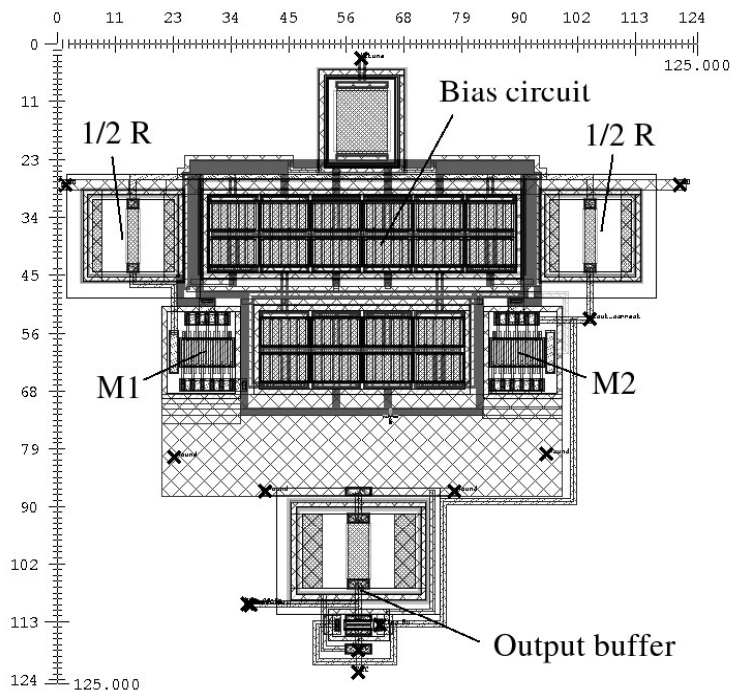

Fig. 4. Layout.

## V. CONCLUSION

In this paper, a brief analysis of a degenerated gyrator has been presented which allows one to intentionally embed a negative resistance inside an active inductor circuit. The presented analysis provides insight onto the behavior of gyrators and allows to derive design criteria. A simulation of an example active inductor demonstrates a compact harmonic oscillator utilizing only parasitic components, thus offering another approach to a circuit miniaturization.

## ACKNOWLEDGMENTS

This work has been carried out as the part of Science Foundation Ireland supported Center for Telecommunications Value Chain Research at the Institute of Microelectronics and Wireless Systems, National University of Ireland, Maynooth, Co. Kildare.

## REFERENCES

- [1] Hayashi, H. and Maraguchi, M.: 'A novel broad-band MMIC VCO using active inductor', Journal of Analog Integrated Circuits and Signal Processing, August 1999, Vol. 20, pp. 103-109
- [2] Szczepkowski, G., Baldwin, G. and Farrell, R.: 'Wideband 0.18  $\mu\text{m}$  CMOS VCO using active inductor with negative resistance', Proc. Eur. Conf. on Circuit Theory and Design, August 2007, Seville, Vol. 3, pp. 990-993
- [3] Hsieh, H., Liao, Y. and Lu, L.: 'A compact quadrature hybrid MMIC using CMOS active inductors', IEEE Transactions on Microwave Theory and Techniques, June 2007, Vol. 55, No. 6, pp. 1098-1104
- [4] Razavi, B.: 'RF Microelectronics' (Prentice Hall PTR, Upper Saddle River, NJ, 1998), p. 212
- [5] Mukhopadhyay, R., Park, Y. Lee, J. S., Cressler, J. D. and Laskar, J.: 'Reconfigurable RFICs for frequency-agile VCOs in Si-based technology for multistandard applications', 2004 IEEE MTT-S International Microwave Symposium Digest, June 2004, Vol. 3, pp. 1489-1492.