

Center of Gravity Estimation and Rollover Prevention Using Multiple Models & Controllers

Selim Solmaz, Mehmet Akar and Robert Shorten

Abstract—In this paper, we present a methodology based on multiple models and switching for real-time estimation of center of gravity (CG) position and rollover prevention in automotive vehicles. Based on a linear vehicle model in which the unknown parameters appear nonlinearly, we propose a novel sequential identification algorithm to determine the vehicle parameters rapidly in real time. The CG height estimate is further coupled with a switching controller to prevent un-tripped rollover in automotive vehicles. The efficacy of the proposed switched multi model/controller estimation and control scheme is demonstrated via numerical simulations.

I. INTRODUCTION

It is well known that vehicles with a high center of gravity such as light trucks (vans, pickups, and SUVs) are more prone to rollover accidents than other types of passenger vehicles. According to recent statistical data [1], this class of vehicles were involved in nearly 70% of all the rollover accidents in the USA during 2004, with SUVs alone were responsible for about half of this total. The fact that the composition of the current automotive fleet in the U.S. consists of nearly 36% light trucks [2], along with the recent increase in their popularity worldwide, makes rollover an important safety problem.

There are two distinct types of vehicle rollover: tripped and un-tripped. A tripped rollover commonly occurs when a vehicle slides sideways and digs its tires into soft soil or strikes an object such as a curb or guardrail. Driver induced un-tripped rollover however, can occur during typical driving situations and it poses a real threat for top-heavy vehicles. Examples are excessive speed during cornering, obstacle avoidance and severe lane change maneuvers, where rollover may occur as a direct result of the lateral wheel forces induced during these maneuvers [2]. Rollover has been the subject of intensive research in recent years, especially by the major automobile manufacturers, and the majority this work is geared towards the development of rollover prediction schemes and robust occupant protection systems. While robust active rollover control systems achieve the goal of preventing this type of accidents, such a control approach may be too conservative, and it can potentially compromise the performance of the vehicle under non-critical driving situations. It is however, possible to prevent

rollover accidents in an effective and efficient manner by continuously monitoring the car dynamics and applying the proper and sufficient control action to recover handling of the vehicle in emergency situations.

The height of CG along with the lateral acceleration are the most important parameters affecting the rollover propensity of an automotive vehicle; while the former is available as part of standard sensor packs, the CG height can not be measured directly [3]. With this background in mind, we first propose our CG estimation method based on multiple models, and then use the technique in designing a switching rollover controller. As part of the feedback implementation we utilize multiple simplified linear models, which are parameterized to cover uncertainty in the vehicle parameters. Switching between these models yields a rapid estimation of unknown and time-varying vehicle parameters through the selected models, which is then used to switch among a set of suitable controllers in order to improve the performance of active rollover mitigation systems.

Our motivation for considering a switching controller implementation is twofold. Firstly, switching controllers are the alternative option to the robust ones and they can potentially provide higher performance. Robust controllers have fixed gains that are chosen considering the worst-case that the plant undergoes; for the rollover problem, the worst operating condition translates to operating the vehicle with the highest possible CG position. While choosing the controller gains for the worst-case guarantees the performance (i.e., safety) under the designed extreme operating condition, the feedback performance of the robustly controlled systems under less severe or even normal operating conditions are suboptimal. Our second motivation is related to the time constant of rollover accidents, which is on the order of seconds. While conventional adaptive controllers are known to have slow convergence rates and large transient control errors when the initial parameter errors are large (a factor that renders these control approaches unsuited for use in rollover mitigation applications), utilization of MMST type algorithms [4] may overcome these problems and provide high performance adaptive controllers. Therefore, when improving the controller performance and speed for the rollover problem is considered, MMST framework becomes an ideal choice as it can provide rapid identification of the unknown parameters as part of the closed loop implementation. This way we can rapidly switch to a controller that is more suitable for the vehicle operating conditions, thus improving the overall safety of the vehicle without sacrificing its performance.

S. Solmaz and R. Shorten are with the Hamilton Institute, NUIM, Ireland (Email:selim.solmaz@nuim.ie, robert.shorten@nuim.ie). M. Akar is with the Department of Electrical and Electronic Engineering, Boğaziçi University, Bebek, İstanbul, 34342, Turkey. Tel: +90 212 3596466. Fax: +90 212 2872465 (E-mail: mehmet.akar@boun.edu.tr).

TABLE I
MODEL VARIABLES

Variable	Description	Value	Unit
m	Vehicle mass	1300	kg
g	Gravitational acceleration	9.81	m/s^2
v_x	Initial longitudinal speed	30	m/s
J_{xx}	Roll moment of inertia at the CG	400	kgm^2
J_{zz}	Yaw moment of inertia at the CG	1200	kgm^2
L	Axle separation	2.5	m
T	Track width	1.5	m
l_v	long. CG position w.r.t. front axle	1.2	m
l_h	long. CG position w.r.t. rear axle	1.3	m
h	CG height over ground	0.51	m
c	suspension damping coefficient	5000	Nms/rad
k	suspension spring stiffness	36000	Nm/rad
C_v	Front tire stiffness coefficient	60000	N/rad
C_h	Rear tire stiffness coefficient	90000	N/rad
δ, β, ϕ	Steering angle, Side-slip angle (at CG), and roll angle, respectively	varying	rad
α_v, α_h	Side-slip angles at the front and rear tire, respectively	varying	rad
$\dot{\psi}, \dot{\phi}$	Yaw rate and roll rate, respectively	varying	rad/s

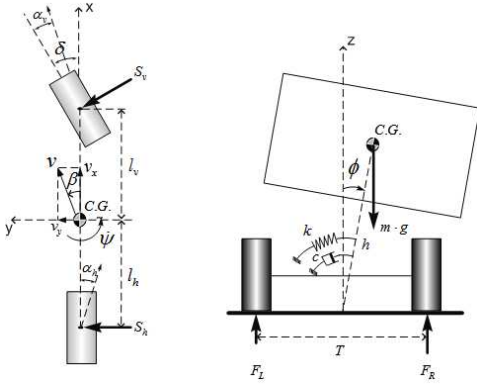

Fig. 1. Single track model with roll degree of freedom.

II. SYSTEM DESCRIPTION

In this section we present the mathematical model capturing the lateral and vertical dynamics of a car. We also define the load transfer ratio as the rollover assessment criterion, and further state our assumptions regarding the actuators and vehicle parameters. For related notation, refer to Table I.

A. Single track model with roll degree of freedom

This is the simplest model with combined roll and lateral dynamics, and is used to represent the real vehicle in our simulations. By assuming that the left and right tires are lumped into a single one at the axle centerline as shown on the left hand side of Fig. 1, the combined horizontal and roll dynamics of the vehicle can be compactly characterized by

$$\dot{x} = Ax + B_\delta \delta + B_u u \quad \text{with} \quad (1)$$

$$A = \begin{bmatrix} -\frac{\sigma J_{xeq}}{m J_{xx} v} & \frac{\rho J_{xeq}}{m J_{xx} v^2} - 1 & -\frac{hc}{J_{xx} v} & \frac{h(mgh-k)}{J_{xx} v} \\ \frac{\rho}{J_{zz}} & -\frac{k}{J_{zz} v} & -\frac{c}{J_{xx}} & \frac{mgh-k}{J_{xx}} \\ -\frac{h\sigma}{J_{xx}} & \frac{h\rho}{J_{xx} v} & 1 & 0 \\ 0 & 0 & 0 & 0 \end{bmatrix}$$

$$B_\delta = \begin{bmatrix} \frac{C_v J_{xeq}}{m J_{xx} v} & \frac{C_v l_v}{J_{zz}} & \frac{h C_v}{J_{xx}} & 0 \end{bmatrix}^T,$$

$$B_u = \begin{bmatrix} 0 & -\frac{T}{2 J_{zz}} & 0 & 0 \end{bmatrix}^T,$$

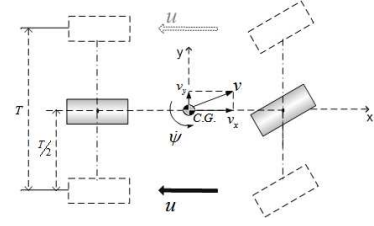

Fig. 2. Differential braking force as control input.

where $x = [\beta, \dot{\psi}, \dot{\phi}, \phi]^T$ is the state; β is the side-slip angle; $\dot{\psi}$ is the yaw-rate; $\dot{\phi}$ is the roll-angle and σ, ρ , and κ are auxiliary parameters that are defined as follows: $\sigma \triangleq C_v + C_h$, $\rho \triangleq C_h l_h - C_v l_v$, $\kappa \triangleq C_v l_v^2 + C_h l_h^2$. Also $J_{xeq} = J_{xx} + mh^2$ denotes the equivalent roll moment of inertia. In the model u represents the total effective differential braking force acting on the wheels about the vertical axis. This force is parallel to the road, and it is positive if the effective braking is on the right wheels and negative if the effective braking is on the left wheels. Differential braking force as the control input is depicted in Fig. 2. In order to model the change in the vehicle longitudinal speed as a result of braking, we assume that the longitudinal wheel forces generated by the engine counteract the rolling resistance and the aerodynamic drag at all times. Under this assumption, the vehicle speed is approximately governed by

$$\dot{v} = -\frac{|u|}{m}. \quad (2)$$

B. The Load Transfer Ratio, LTR_d

The vehicle load transfer ratio (LTR) is defined by

$$LTR = \frac{\text{Load on Right Tires} - \text{Load on Left Tires}}{\text{Total Load}}. \quad (3)$$

Clearly, LTR varies within $[-1, 1]$, and it is equal to zero for a symmetric car that is driving straight. The bounds $LTR \in \{-1, 1\}$ are reached in the case of a wheel lift-off on either side of the vehicle. This indication capability of the LTR is useful in design of rollover prevention schemes. A dynamical approximation for the load transfer ratio, denoted LTR_d , is given as follows [2]

$$LTR_d = -\frac{2(c\dot{\phi} + k\phi)}{mgT}. \quad (4)$$

C. Actuators and Vehicle parameters

1) *Actuators*: Rollover prevention techniques may rely on several actuation mechanisms including active steering, active suspension, active roll stabilizer bars and differential braking. Among these techniques, differential braking systems can be found in almost every class of passenger vehicles through ABS (Anti-lock Braking System) and thus it has been used extensively for rollover prevention [5], [6]. It is the most effective way to manipulate the tire forces, and

it is the only one that can reduce the vehicle longitudinal speed among the afore-mentioned actuator types. Although the switching rollover controller to be described in this paper can easily be extended to other types of actuators, differential braking will be adopted in the sequel.

2) *Parameters*: We assume that vehicle mass m is known, which can be estimated as part of the braking system [2]. Furthermore C_v, C_h, l_v, k, c and h are all assumed be *unknown* parameters of the vehicle and are estimated through the multiple model identification algorithm. We further assume that these parameters vary within certain closed intervals $C_v \in \mathbb{C}_v, C_h \in \mathbb{C}_h, l_v \in \mathcal{L}_v, c \in \mathbb{C}, k \in \mathcal{K}$ and $h \in \mathcal{H}$, and these intervals can be found via accurate numerical simulations as well as field tests.

III. VEHICLE PARAMETER IDENTIFICATION

The problem in hand is to determine the vehicle parameters that have been described in the previous section. While linear regression techniques, including least squares identification can be tried, such methods require persistently exciting input signals [7], which might impose unrealistic and dangerous maneuvers. Moreover, note that the linear model introduced in Section II is nonlinear in the unknown vehicle parameters further complicating the formulation of the estimation problem using the traditional approaches. Thus, there is a need for alternative techniques for vehicle parameter identification, which imposes no restriction on the driver input, has fast convergence rates and requires minimum additional output information (sensors).

With the above motivation in mind, we now introduce our multiple model based identification algorithm to determine the unknown vehicle parameters rapidly in real-time. To this end, a first step approach would be to setup the multiple identification models using (1) with $u = 0$. However in this case, the resulting parameter space will be too complex to handle. Instead we adapt a modular estimation strategy of decoupling the vehicle dynamics into subsystems by assuming a weak relationship from the roll dynamics onto the lateral.

A. Identification of lateral dynamics parameters

The identification of the longitudinal CG location l_v and the lateral tire stiffness parameters C_v, C_h makes use of the yaw-rate equation in (1), i.e.,

$$\ddot{\psi} = \frac{C_h l_h - C_v l_v}{J_{zz}} \beta - \frac{C_v l_v^2 + C_h l_h^2}{J_{zz} v} \dot{\psi} + \frac{C_v l_v}{J_{zz}} \delta. \quad (5)$$

Define the filtered signals $\omega_l \in \mathfrak{R}^3$

$$\dot{\omega}_l = \lambda_1 \omega_l + [\beta, \dot{\psi}, \delta]^T, \quad (6)$$

where $\lambda_1 < 0$. By following the standard arguments in identification [7], (5) can be rewritten as

$$\dot{\psi} = \theta^{*T} \omega_l, \quad (7)$$

where $\theta^* \in \mathfrak{R}^3$ represents the parameter vector, from which the vehicle parameters can be determined as follows:

$$l_v^* = \frac{L(\theta_1^* + \theta_3^*) - v(-\lambda_1 - \theta_2^*)}{\theta_1^*}, \quad (8)$$

$$C_v^* = \frac{J_{zz} \theta_3^*}{l_v^*}, \quad C_h^* = \frac{J_{zz}(\theta_1^* + \theta_3^*)}{L - l_v^*}. \quad (9)$$

The multiple model based identification algorithm to determine the longitudinal CG location l_v and the tire stiffness parameters C_v, C_h assumes that each unknown parameter belongs to a closed interval such that $C_v \in \mathbb{C}_v, C_h \in \mathbb{C}_h$, and $l_v \in \mathcal{L}_v$. These intervals are divided into certain number of grid points that can be represented as $\mathbb{C}_v = \{C_{v_1}, C_{v_2}, C_{v_3}, \dots, C_{v_p}\}$, $\mathbb{C}_h = \{C_{h_1}, C_{h_2}, C_{h_3}, \dots, C_{h_q}\}$, and $\mathcal{L}_v = \{l_{v_1}, l_{v_2}, l_{v_3}, \dots, l_{v_r}\}$ with dimensions p, q and r , respectively. These grid points form the $p \times q \times r$ fixed identification models. Additionally, we employ one *free running adaptive model*, and one *re-initialized adaptive model* [4]. The identification error, e_i , corresponding to the i^{th} model is defined as

$$e_i = \dot{\psi} - \hat{\dot{\psi}} = (\theta^* - \hat{\theta}_i)^T \omega_l, \quad (10)$$

where $\hat{\theta}_i$ denotes the parameter of the i -th model. The vehicle parameters are estimated as the parameters of the i^* -th model

$$i^* = \arg \min_{i \in \{1, 2, \dots, n\}} J_i(t), \quad (11)$$

where $J_i(t)$ is the cost corresponding to the i^{th} identification error and is given by [4]

$$J_i(t) = \alpha_c \|e_i(t)\| + \beta_c \int_0^t e^{-\lambda_c(t-\tau)} \|e_i(\tau)\| d\tau. \quad (12)$$

In (12), α_c and β_c are non-negative design parameters controlling the relative weights given to transient and steady state measures respectively, whereas λ_c is the non-negative forgetting factor.

B. Identification of roll dynamics parameters

Given the vehicle lateral dynamics parameters, l_v^*, C_v^* , and C_h^* , we now proceed to determine the suspension parameters k, c and the CG height h by utilizing the roll dynamics equation in (1) which is given below

$$J_{xx} \ddot{\phi} + c \dot{\phi} + k \phi = J_{xx} h \bar{\delta}, \quad (13)$$

where the auxiliary input signal $\bar{\delta} \in \mathfrak{R}$ is given by

$$\bar{\delta} = \frac{1}{J_{xx}} \left(-(C_v + C_h) \beta + \frac{J_{zz} \theta_1}{v} \dot{\psi} + mg \phi + C_v \delta \right) \quad (14)$$

We further define the filtered signal $\omega_v \in \mathfrak{R}^3$ as

$$\dot{\omega}_v = \lambda_2 \omega_v + [\dot{\phi}, \phi, \bar{\delta}]^T, \quad (15)$$

where $\lambda_2 < 0$. Hence, the roll-rate equation (13) can be parameterized as

$$\dot{\phi} = \Xi^{*T} \omega_v, \quad (16)$$

where $\Xi^* \in \mathbb{R}^3$ represents the parameter vector. The vehicle parameters suspension parameters and the CG height are related to Ξ^* as follows:

$$c^* = (-\lambda_2 - \Xi_1^*)J_{xx}, \quad k^* = -\Xi_2^*J_{xx}, \quad h^* = \Xi_3^*. \quad (17)$$

Analogous to the lateral vehicle parameter estimation, each unknown parameter belongs to a closed interval such that $h \in \mathcal{H}$, $k \in \mathcal{K}$, and $c \in \mathcal{C}$. These intervals are divided into sufficient number of grid points and are represented as $\mathcal{H} = \{h_1, h_2, h_3, \dots, h_p\}$, $\mathcal{K} = \{k_1, k_2, k_3, \dots, k_q\}$, and $\mathcal{C} = \{c_1, c_2, c_3, \dots, c_r\}$ with dimensions p, q and r respectively. Hence we employ these $p \times q \times r$ fixed models together with one *free running adaptive* and one *re-initialized adaptive* model in the multiple model extension. Once again, the identification error, \bar{e}_i , corresponding to the i^{th} model is defined as

$$\bar{e}_i = \dot{\phi} - \hat{\phi} = (\Xi^* - \hat{\Xi}_i)^T \omega_v, \quad (18)$$

where $\hat{\Xi}_i$ denotes the parameter of the i -th model. Subsequently, one can compute the associated cost value (12) corresponding to each identification error (18). Finally, the model that is obtained from (11) yields the roll-plane parameters, including the CG height and suspension parameters.

C. Numerical Analysis

In this section, we combine the identification schemes described above as a two step algorithm, whose first step estimates the lateral vehicle parameters C_v , C_h and l_v at each instant, and passes these values to the second step in which we determine the suspension parameters c , k and the center of gravity height h .

Now we investigate whether the multiple model scheme using the proposed two step algorithm has any advantages over the same two step algorithm that employs conventional type adaptation. To this end, suppose we choose the vehicle parameter grid points for the fixed candidate models for the lateral dynamics as $l_v \in \{1.01, 1.11, \dots, 1.61\}$, $C_v \in \{57600, 60100, 62600\}$, and $C_h \in \{87600, 90100, 92600\}$. Similarly, we choose grid points for the fixed candidate roll plane models as $h \in \{0.5, 0.52, \dots, 0.84\}$, $k \in \{35500, 36100, 36700\}$, and $c \in \{4760, 5010, 5260\}$. We note that the simulated reference vehicle parameters of $h^* = 0.51$, $k^* = 36000$, $c^* = 5000$, $l_v^* = 1.2$, $C_v^* = 60000$, $C_h^* = 90000$ are not in the fixed candidate model parameter set. As shown in Figs. 3–4, the free running adaptive model that is initialized to the lower bounds of the intervals does worse than the proposed adaptive multiple model identification algorithm. In particular, we observe that the free running adaptive model can have a significant transient estimation error.

IV. SWITCHING ROLLOVER CONTROLLER

We now combine the multiple model identification scheme discussed in the previous section with a paired set of controllers in order to improve the performance of active rollover mitigation systems. The controller design described

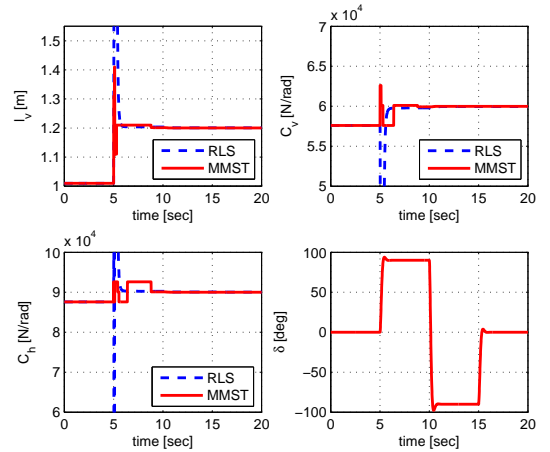

Fig. 3. CG longitudinal position and tire stiffness estimations.

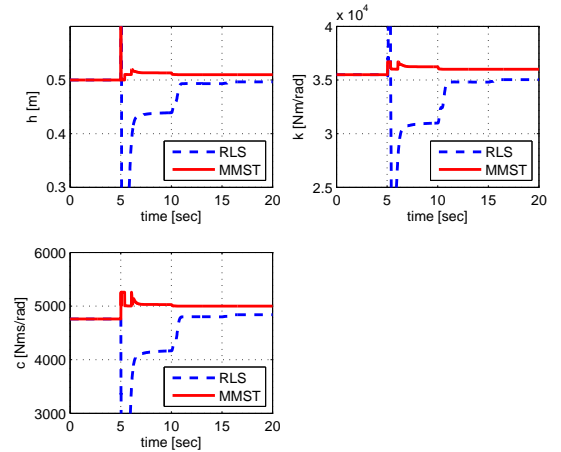

Fig. 4. CG height and suspension parameter estimations.

in the sequel is based on differential braking actuators only; however, the results can be extended to other actuator types such as the active steering and active/semi-active suspension with ease.

We emphasize that for the rollover prevention problem a single robust control mechanism may be designed for the worst case scenario, i.e., for the highest possible CG height. While such a strategy makes sense, in that, safety comes first in rollover prevention, it also takes away from performance considerably as the controller will always be on. In order to possibly reduce the degradation in system performance while still preventing rollover, we therefore propose the multi model/controller implementation shown in Figure 5. Before we synthesize a paired set of controllers corresponding to each CG height configuration, we discuss the design of a single rollover controller.

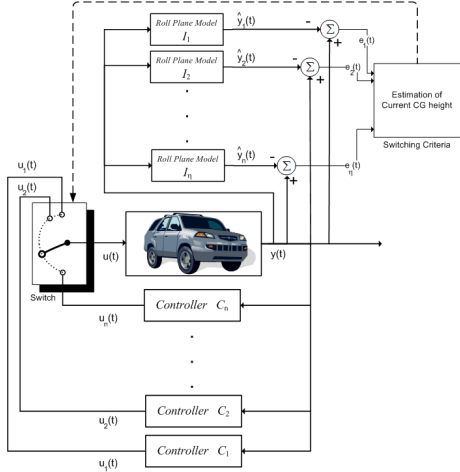

Fig. 5. Multiple model switched adaptive control structure.

A. Rollover controller based on a single model

Due its simplicity and its adequate performance in rollover prevention [5], [6], we adopt a proportional feedback controller of the form

$$u = K_0 a_y, \quad (19)$$

where $a_y = v_x(\dot{\beta} + \dot{\psi})$ is the measured lateral acceleration, and the feedback gain K_0 is chosen to maximize some system performance criterion. Suppose that the CG height h_0 is known. In this paper, we use the single track model with roll degree of freedom in (1) to choose the feedback gain, K_0 , such that the peak value of LTR_d is below some pre-specified level. In other words, we want to keep

$$|LTR_d| \leq 1, \quad (20)$$

for the largest possible steering inputs, which is equivalent to keeping all four wheels in contact with the road and thus preventing rollover. This design is done such that (20) is satisfied for a given maximum speed v_{max} and a given maximum steering input δ_{max} . This in turn will guarantee that $|LTR_d| \leq 1$ for all $|\delta| < |\delta_{max}|$ and $v < v_{max}$ corresponding to the CG height h_0 . In this respect, $u = K_0 a_y$ is a robust controller for all CG height $h \leq h_0$ as well.

Comment: Note that a disadvantage of the controller designed as above is that it is always active. In other words, it will always attempt to limit the LTR_d , even in non-critical situations, thus potentially interfering with, and annoying the vehicle driver. It therefore makes sense to activate the controller in situations only when the potential for rollover is significant [2]. One can limit this by putting a threshold output for the activation of the controllers. Since the system output considered here is the lateral acceleration, we adopt the following rule for activating the switched controllers

$$u = \begin{cases} K_0 a_y, & \text{if } |LTR_d| \geq LTR_{thr}, \\ 0, & \text{if } |LTR_d| \leq LTR_{thr}, \end{cases} \quad (21)$$

where LTR_{thr} is a positive threshold that depends on the vehicle type and parameters (for the simulations of this paper, $LTR_{thr} = 0.6$ has been used).

B. Switched Rollover Prevention

In the proposed multiple model/controller architecture shown in Figure 5, n identification models are paired up with n locally robust controllers. For each combination of $h \in \{h_1, \dots, h_p\}$, $k \in \{k_1, \dots, k_q\}$, and $c \in \{c_1, \dots, c_d\}$, a paired local controller $C_i \in \{C_1, C_2, \dots, C_n\}$ is designed as discussed above; hence we have

$$C_i: \quad u_i = K_i a_y, \quad i \in \{1, 2, \dots, n\}, \quad (22)$$

which yields higher performance for the current values of h , k , and c . In the execution of the proposed rollover scheme, the best model is identified based on the 2nd order roll plane model (13) and the corresponding controller C_i is used in rollover prevention.

V. NUMERICAL ANALYSIS

In this section, we investigate the performance of the CG estimation algorithm, and its application in rollover prevention. The simulation results to be presented assume the set of synthetic parameters given in Table I. In the numerical simulations we assume that the lateral vehicle parameters l_v, C_v, C_h are fixed and known, but roll dynamics parameters k, c, h are unknown. The rationale for this is twofold; firstly it reduces the controller implementation complexity, thus helping with exposing the benefits of the control approach discussed in this paper. Secondly, the major parameters affecting roll dynamics behavior are k, c and h , which necessitates continuous monitoring of these parameters in rollover situations, whereas the estimation of the lateral dynamics parameters can be achieved during normal driving conditions, long before a rollover situation is likely to occur at freeway speeds. With these in mind, we use the same fixed candidate model set as in Section III-C. We emphasize that the simulated vehicle roll dynamics parameters of $h^* = 0.51$, $k^* = 36000$, $c^* = 5000$ are not in the fixed candidate model parameter set. Motivated by the ease of exposition, we further assume that controller switching is based on the estimated CG height only.

For the design of local controllers, we assume a peak vehicle speed of $v_{max} = 30[m/s]$ (i.e. $108[km/h]$), which represents typical freeway driving condition for a compact passenger vehicle. The peak steering wheel input of $\delta_{max} = 100^\circ$ (with steering ratio of $1/18$) is used to design the switched controllers such that, when the vehicle is operating at δ_{max} and v_{max} , the condition (20) satisfied for each CG height configuration, which is sufficient for mitigating rollover. We choose the controller gains K_η as small as possible to minimize the control effort. The resulting 8 controller gains are calculated as follows:

$$\left. \begin{array}{ll} K_{h>0.8} = -1550 & , \quad K_{0.75<h\leq 0.8} = -1350 \\ K_{0.7<h\leq 0.75} = -1170 & , \quad K_{0.65<h\leq 0.7} = -1000 \\ K_{0.6<h\leq 0.65} = -850 & , \quad K_{0.55<h\leq 0.6} = -700 \\ K_{0.5<h\leq 0.55} = -580 & , \quad K_{h\leq 0.5} = -480 \end{array} \right\} \quad (23)$$

For the numerical simulations, we use a typical obstacle avoidance maneuver known as the Elk test with a peak

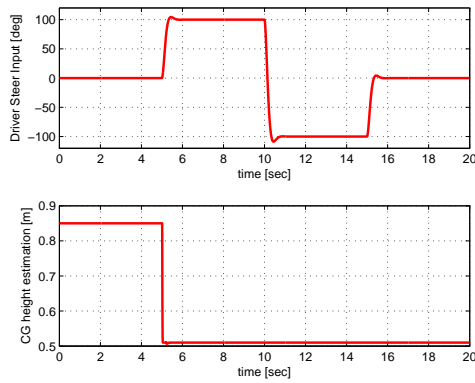

Fig. 6. Steering input and the resulting CG height estimation.

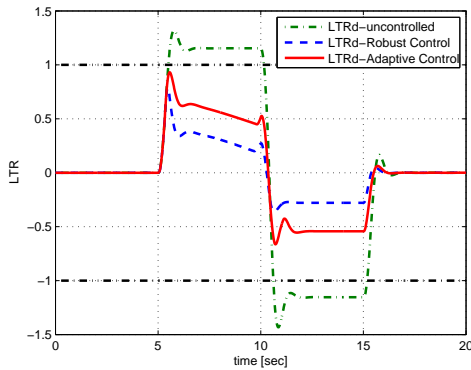

Fig. 7. LTR_d for the controlled and uncontrolled vehicles.

driver steering input of magnitude $\delta_{max} = 100^\circ$ and with an initial speed of $v = 108[km/h]$. The steering profile corresponding to this maneuver and the resulting CG height estimation is shown in Fig. 6, where the worst case CG height (i.e., $h_{max} = 0.85[m]$) is assumed until the initiation of the steering maneuver. After the maneuver starts, the CG height has been estimated to be $0.51[m]$ as seen from the figure. Fig. 7 depicts the resulting LTR_d values for the controlled and the uncontrolled vehicles. Clearly, the uncontrolled vehicle rolls over as $|LTR_d| > 1$ during the maneuver. Moreover, both of the robust (i.e., fixed gain) and the switched adaptive controllers prevent rollover by keeping $|LTR_d| < 1$. However, the adaptive controller does it in a less conservative way which is favorable. In Fig. 8 we compare the vehicle states of the controlled and the uncontrolled vehicles, where we observe that due to smaller attenuation obtained by the adaptive (switched) controller, the resulting states trajectories are closer to the uncontrolled vehicle states as compared to the robust one. Again, this is favorable as the adaptive controller causes smaller driver intervention, and maintains a natural response of the vehicle. Finally, Fig. 9 depicts the vehicle speed and the normalized braking force variations for the controlled and the uncontrolled vehicles. We observe that the adaptive controller results in much

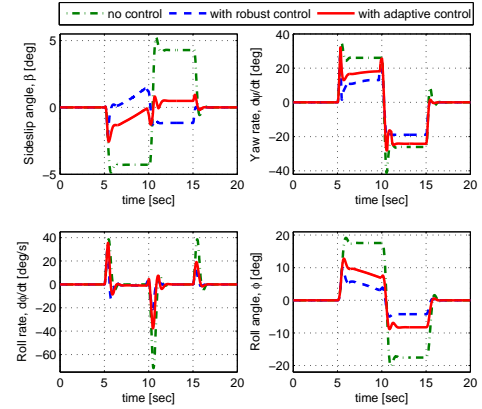

Fig. 8. Vehicle states for the controlled and uncontrolled vehicles.

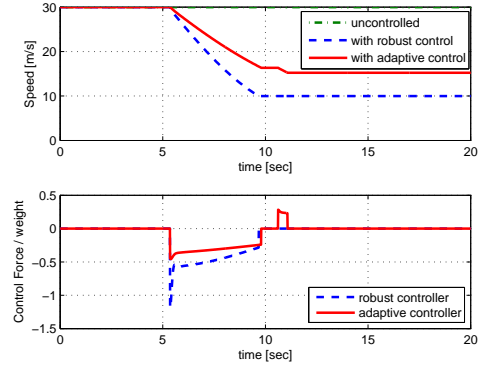

Fig. 9. Vehicle speed and the normalized control force.

less controller actuation and less drop in vehicle speed; this clearly shows the performance benefit of using the suggested switched controller as compared to the fixed robust control alternative.

ACKNOWLEDGEMENT

This work was jointly supported by the following grants: SFI 04/IN3/I478, TUBITAK 107E276, and EI PC/2007/0128.

REFERENCES

- [1] Traffic wafaty facts 2004: A compilation of motor vehicle crash data from the fatality analysis reporting system and the general estimates system. Technical report, NHTSA, 2006.
- [2] S. Solmaz. *Topics in automotive rollover prevention: Robust and adaptive switching strategies for estimation and control*. Phd thesis, Hamilton Institute, NUI-Maynooth, Dec. 2007. Available online at <http://www.hamilton.ie/publications/thesis.htm>.
- [3] M. Akar, S. Solmaz, and R. Shorten. Method for determining the center of gravity for an automotive vehicle, (WO 2007/098891 A1).
- [4] K.S. Narendra and J. Balakrishnan. Adaptive control using multiple models. *IEEE Trans. on Automatic Control*, 42(2):171–187, 1997.
- [5] B. Chen and H. Peng. Differential-braking-based rollover prevention for sport utility vehicles with human-in-the-loop evaluations. *Vehicle System Dynamics*, 36:359–389, 2001.
- [6] Wielenga T.J., 1999, A Method for Reducing On-Road Rollovers: Anti-Rollover Braking. *SAE Paper* No. 1999-01-0123.
- [7] Narendra K.S., Annaswamy A. M., 1989, *Stable Adaptive Systems*, (Prentice Hall International, Englewood Cliffs - NJ, U.S.A.).