

# *Wireless Sensor System for Prediction of Carbon Monoxide Concentration using Fuzzy Time Series*

Suryono Suryono  
Department of Physics & Graduate School of  
Information System  
Diponegoro University, Semarang, Indonesia 50273  
e-mail : [suryono@fisika.undip.ac.id](mailto:suryono@fisika.undip.ac.id)

Ragil Saputra  
Department of Information Technology,  
Diponegoro University, Semarang, Indonesia 50273  
E-mail: [ragil.saputra@undip.ac.id](mailto:ragil.saputra@undip.ac.id)

Bayu Surarso  
Department of Mathematics & Graduate School of  
Information System  
Diponegoro University, Semarang, Indonesia 50273  
E-mail: [bayusurarso@yahoo.com](mailto:bayusurarso@yahoo.com)

Ali Bardadi  
Graduate School of Information System  
Diponegoro University, Semarang, Indonesia 50241  
E-mail: [alibardadi@gmail.com](mailto:alibardadi@gmail.com)

**Abstract** - Carbon monoxide (CO) concentration produced from incomplete material burning affects both work health and safety. A smart system capable of early detection of carbon monoxide (CO) concentration is therefore required. This research develops a carbon monoxide sensor detection capability using a wireless sensor system that transmits data to the web server via internet connection. A semiconductor CO sensor is installed in a remote terminal unit. A computer application is developed for data acquisition and sending via online and in real time to a web server using an internet modem. For a web-based prediction of CO concentration, a Fuzzy Time Series algorithm induced by Pritpal Sing matrix is used. This research uses CO concentration data for two months. The resulting carbon monoxide concentration prediction is displayed in real time on a dashboard. This prediction is for the next day's forecast. Results show that the Fuzzy Time Series that is induced by Pritpal Sing matrix has an average error of 2.67 %, calculated with its average forecasting error rate (AFER). This error value varies, depending on the number of data and data characteristics.

**Keywords**— *error percentage; Internet connection; on-line; prediction; real time; wireless*

## I. INTRODUCTION

Measurement and prediction of carbon monoxide (CO) concentration is necessary as it plays a significant role in work safety, health, and environmental quality. Carbon monoxide (CO) is detrimental to human being. This type of air pollution is due to incomplete burning of hydrocarbon materials. Carbon monoxide inhalation causes severe consequences and it even leads to death [1]. Carbon monoxide (CO) does not have either smell or color that it is hard for our senses to detect. Therefore, an instrument that can electronically detect and measure CO concentration is needed. This prompt monitoring and measuring will prevent severe consequences to the environment [2]. The rate of change in carbon monoxide concentration in the environment is not linear and is affected by many factors. Nowadays, industrial

development is growing rapidly. Industrial machines have greatly contributed to environmental pollution with their carbon monoxide output. Prediction for possible effects of disasters caused by carbon monoxide is necessary for early prevention measures. Therefore, a quick prediction system that can work non-linearly based on inferences like the fuzzy method is carried out in this research.

The spread of CO concentration alters swiftly depending on environmental conditions. This gas may disperse in wide areas and may come from multiple source points. Hence, an effective and economical device for its measurement is required. This efficiency can be reached with the use of a simple, smart, and cheap instrument that is equipped with wireless interfaces that are capable of communicating with one another [3]. Measurement of it is usually only carried out at one point in a wide area and it is done manually. This method is incapable of describing CO concentration in real-time at the measured point as gas has an inherent property of keep on changing its concentration. The use of wireless sensor technology takes care of the problem with distance and data continuity [4]. Measurement of CO using wireless sensors in this research is expected to anticipate changes in CO concentration, and that one point and the others can be connected as to describe the whole dynamic of CO concentration changes in an area.

Prediction of CO concentration will only be useful if it is precise enough. This condition can be achieved with the use of the Fuzzy Time Series (FTS) that is based on the fuzzy logic principles [5]. This is the best fit for a high speed online prediction system as it does not require a complicated operational learning system. Hence, FTS can readily determine effective lengths of intervals in modelling and analyzing time series data, even with a small number of historical data [6].

## II. REALIZATION OF SYSTEM

A wireless sensor system consists of sensors that convert physical parameters in the Remote Terminal Unit (RTU) and wirelessly send readings to the web server. Wireless sensor network is advantageous in that data acquisition can be conducted in real time [7]. An overview of a WSN system is shown in Figure 1.

Sensors in the wireless sensor are equipped with a wireless interface that enables them to communicate with one another in order to create a network [3]. The main components of a WSN are sensor node, base station, database, and web server. The base station receives measurement data from the sensor node that is periodically distributed and then these data are forwarded to the server database for storage and management [8].

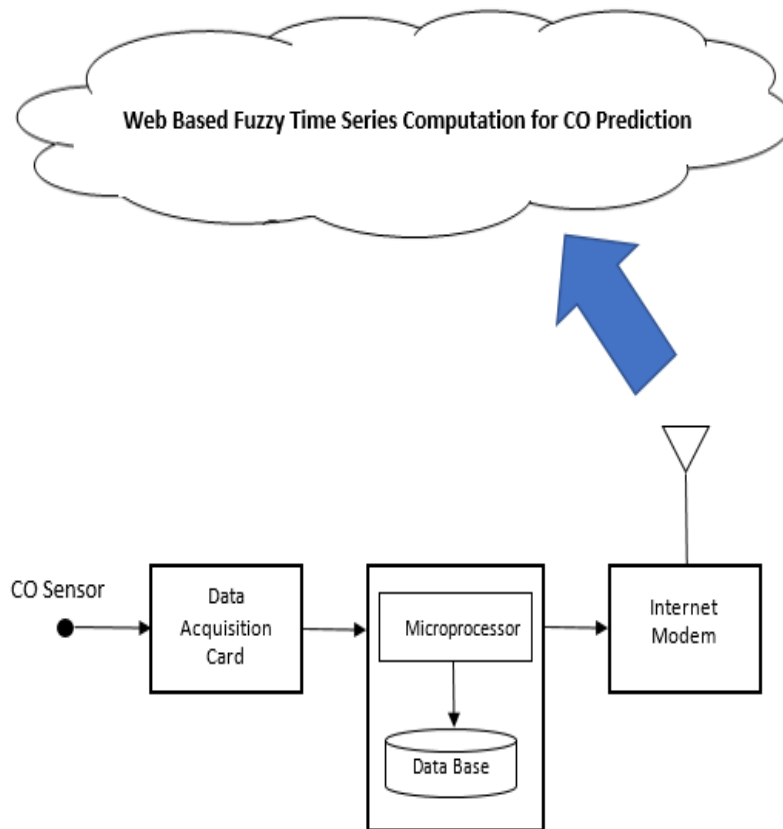

Fig. 1. Overview of carbon monoxide wireless sensor for online system

This research deploys an electronic CO sensor that alters CO concentration (ppm) into electrical signals. When CO hits the SNO<sub>2</sub> semiconductor layer on the sensor, there will be a change in electron mobility that in turn alters the value of electrical resistance. This property is evident when one of the SNO<sub>2</sub> semiconductor tips is given electrical voltage ( $V_{cc}$ ). A resistance load given on the other tip of the semiconductor will yield a CO concentration value shown as voltage ( $V_{out}$ ) on that RL resistor. A circuit of the CO sensor used in this research is depicted in Figure 2.

The sensor used has a VI output voltage from 12 bit ADC reading against non-linear concentration. Therefore, a characterization between incoming concentration and standard gas measurement device is made. The result from this is put into a computer program in order to have

concentration reading that matches the actual concentration. The RTU computer functions to acquire sensor data, store those data, and send them via an internet network. A socket programming is embedded into the RTU computer to read CO data sent to the microcontroller. The computer and microcontroller themselves are connected to the UART serial protocol via a COM1 port. Then the data acquisition system is run by a socket programming that reads that COM1 port.

The website server is programmed to access the RTU database. This database reading is then used for prediction using the Pritpal Singh fuzzy time series. Its model prediction has a new discretization approach referred to Mean-Based Discretization (MBD) for determining the universe of discourse of the historical time series data set and partitioning it into different lengths of intervals.

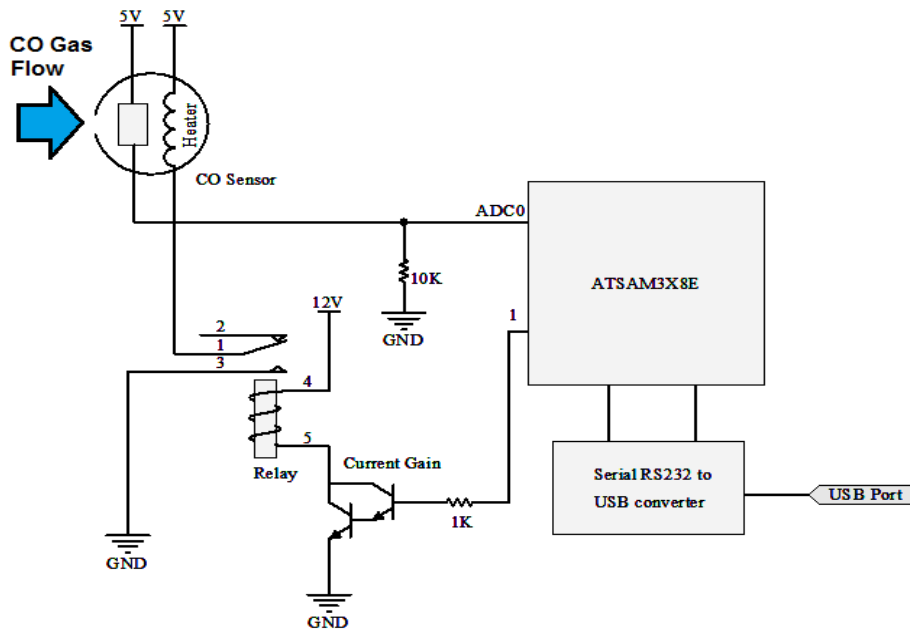

Fig. 2. A Carbon monoxide sensor and interface circuit

The programming steps of the prediction of carbon monoxide concentration using Fuzzy time series system are shown in Figure 3. The algorithm of Pritpal Singh fuzzy time series model is described below (9):

- Phase 1. Partition the time series data set into different lengths of intervals Based on the MBD approach, the historical time series data set is partitioned into different lengths of intervals.
- Phase2. Define linguistic terms for each of the interval. The historical time series data set is divided to several intervals. Therefore, a total number of linguistic variables are defined.
- Phase 3. Developed Fuzzy the time data set. If one number value belongs to interval  $b_i$  the fuzzy data value for that time is considered as  $B_i$ .
- Phase 4. Establish the Fuzzy Logical Relationship (FLR) between fuzzy time series values.
- Phase 5. Create the Fuzzy Logical Relationship Group (FLRG).
- Phase 6. De-fuzzy the fuzzy time series data sets.

To measure the deviation of the models which have been built, we use Mean Absolute Percentage Error (MAPE) as in equation (1):

$$MAPE = \frac{1}{n} \sum_{t=1}^n \left| \frac{Actual\ value(t) - Forcas(t)}{Actual\ value(t)} \right| \quad (1)$$

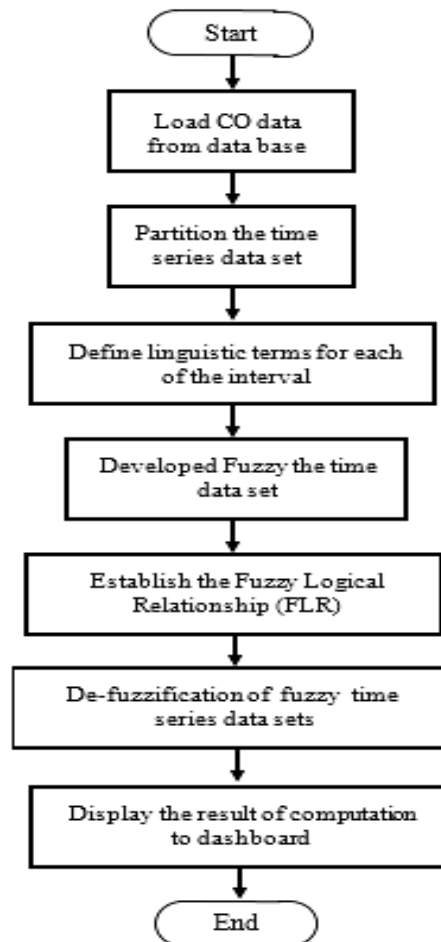

Fig. 3. The programming steps of the prediction of carbon monoxide concentration using Fuzzy time series system

### III. RESULT AND DISCUSSION

Results of sensor circuit characterization is shown by the relationship of CO concentration (ppm) measured using standard equipment against that from analog to digital converter reading in the computer. The resulting characteristics lead to a formula shown in a graph in Figure 4a. This graph indicates that the relationship of CO concentration and electrical output of sensor is nonlinear. This graph yields sensor characteristic relationship of  $y = 1.69x^4 - 48.31x^3 + 510.53x^2 - 2455.50x + 4976.70$ , where  $x$  is CO concentration, while  $y$  is the number of data acquisition.

The formula obtained from graph fitting method shows a physical relationship between the input (CO concentration) and the resulting electric voltage as the output. The graph below shows that there is a relationship of both on the fourth (4th) order polynomial. This formula depends largely on the material used for the sensor. The sensors used here are

semiconductors with its inherent property of electron mobility, depending on the concentration of gas the material detects. The resulting sensor characteristics graph reveals the relationship between the input (CO concentration) and the output (sensor voltage) to be in the fourth (4th) order polynomial.

The resulting sensor characteristics requires an 'inverse transform' computation on the data acquisition computer program. The computer must inverse and send data to the website. These data are CO concentrations from the voltage data gained taken from the ADC. Calibration for inversion result using standard instrument is the next thing to do. The resulting calibrated values are shown in a graph in Figure 4b. The resulting calibrated linear coefficient correlation from computer measurement with standard instrument is 97.6%, with a standard error of 0.023 ppm. This testing result proves that the concentration measurement system developed here has a good agreement with standard measurement devices.

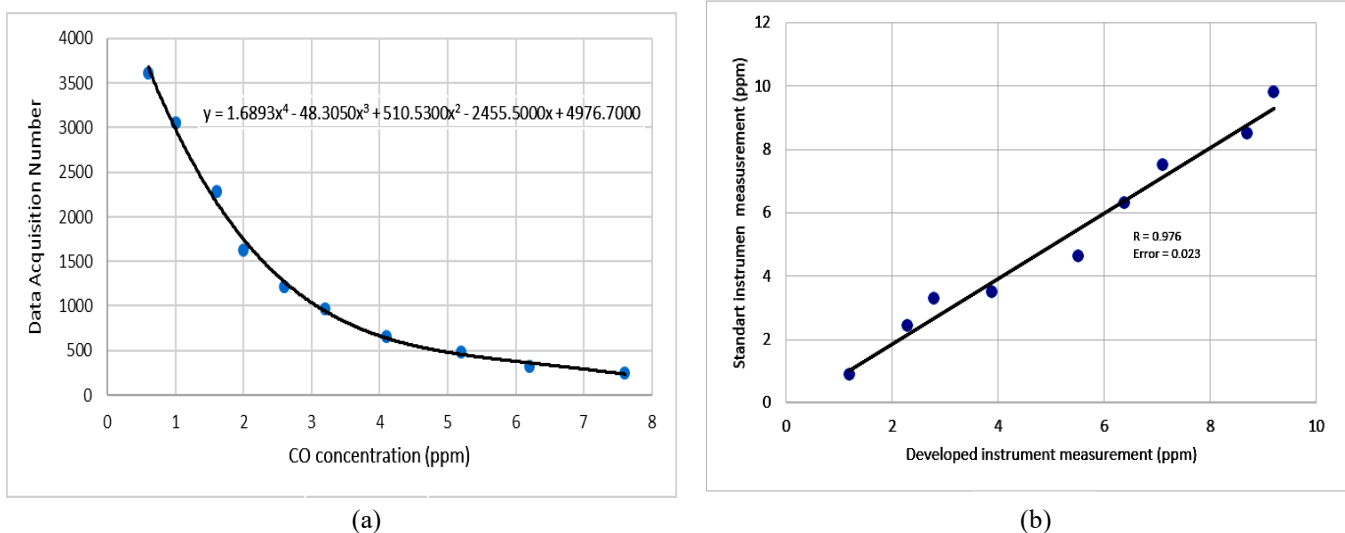

Fig. 4. Characteristic result from the sensor circuit (a) and calibration sensor with standard instrument (b)

A data acquisition system has been successfully developed in this instrument and kept in the RTU computer database. Acquired data will be shared using an internet broadband to the webserver. A data acquiring program has also been developed in web server, along with a data forecasting program. Therefore, forecasting results are kept in the web server database and shown in graphs. An example of this graph is shown in Figure 5.

Predicted data can be observed by all users from any spot with internet access. Hence, this system is capable of inter-region, and even inter-nation, monitoring. This system has successfully addressed spatial discrepancy in which measurement and prediction of CO concentration cannot be carried out in situ. Moreover, this system is also multi service in nature, that CO concentrations from many

different points in an area can be reported at the same time and in real-time. Data of CO concentrations from both acquisition and prediction can be downloaded in a spreadsheet to be used for further analyses.

The graph in Figure 5 shows that data sent from field instruments to the database at the web service fluctuate from time to time. Field observations show that arrangements for this system have been properly set. Therefore, these fluctuations are usually the effect of machines local people use, be they vehicles or factory machineries. The graph below shows actual and predicted values. Values from prediction are one step ahead of actual values. However, both values are usually close to one another, and this represents the efficacy of the system. Overall, precision of

these predicted values can be calculated using the fuzzy time series.

The Pritpal Singh fuzzy time series model can be implemented on time series data of CO concentration. This is justified by prediction results which are close to actual data. Concentration prediction using fuzzy time series with the Pritpal Singh method implemented here delivers a mean error

of 2.67 %, which is measured with its average forecast error rate (AFER). This error value varies, depending on the number of data and data characteristics error value varies, depending on the number of data and data characteristics.

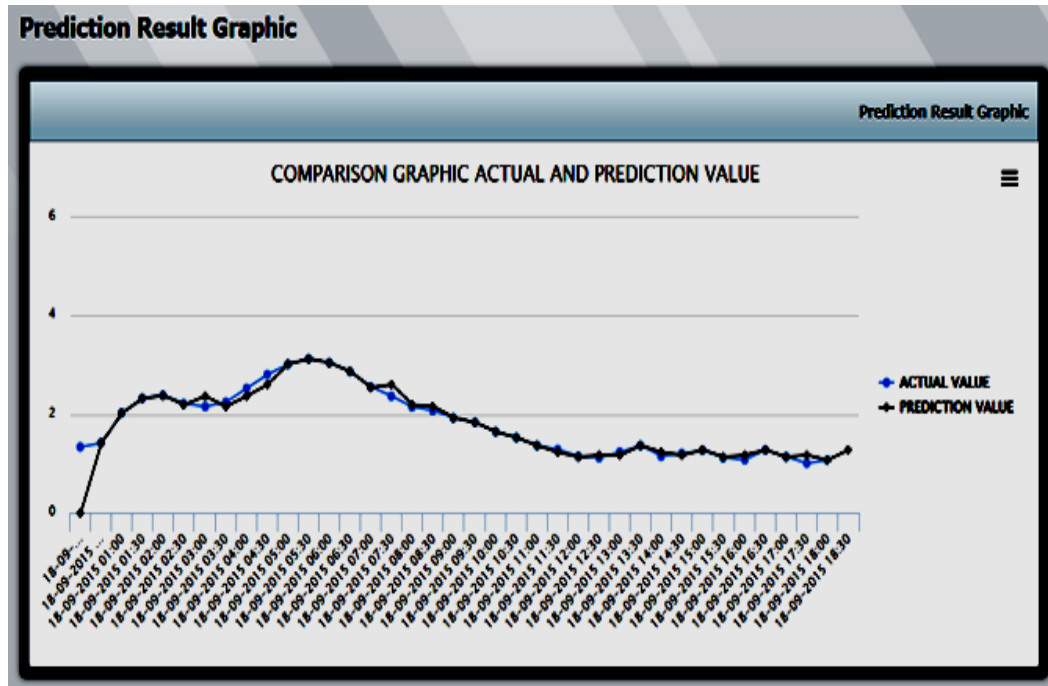

Fig. 5. Graphical representation of forecasting result

#### IV. CONCLUSION

Carbon monoxide (CO) concentration has been successfully predicted online with a WIFI network. This prediction system requires both a gas sensor circuit and a computer based data acquisition system. A website server is needed for data communication from a Remote Terminal Unit (RTU). A system developed in the RTU has successfully forecasts CO concentration with the help of the fuzzy time series with Pritpal Singh algorithm. The resulting prediction is kept in a database and shown as graphs. The system developed in this research is capable of proper CO concentration prediction. Concentration prediction using fuzzy time series with the Pritpal Singh method implemented here delivers a mean error of 2.67 %, which is measured with its average forecast error rate (AFER). This error value varies, depending on the number of data and data characteristics.

#### REFERENCES

- [1] F. Li, H.C. Chan, S. Liu, H. Jia, H. Li, Y. Hu, Z. Wanga, and W. Huang, "Carbon monoxide poisoning as

a cause of death in Wuhan, China: A retrospective six-year epidemiological study (2009–2014)", *International Journal of Forensic Science International* Vol .253 pp.112–118, 2015.

- [2] Z. Mahdaviifar, N. Abbasi, and E. Shakerzadeh, "Carbon monoxide monitoring using pristine and Cu-functionalized aluminum nitride and silicon carbide nanotubes", *International Journal of Molecular Liquids*, Vol. 204, pp. 147–155, 2015.
- [3] J. Yick, B. Mukherjee, and D. Ghos, "Wireless sensor network survey", *Computer Networks* 52, pp. 2292–2330, 2011.
- [4] C. Jun, Y.U. Sun-Zheng, and L. Jing-li, "The design of a wireless data acquisition and transmission system", *Journal of Networks*, Vol. 4, No. 10, 2009.
- [5] Q. Song and B.S. Chissom, "Forecasting enrollments with fuzzy time series", *International, Journal of Fuzzy Set and System* Vol. 54, pp. 1-9, 1993.
- [6] S. Xihao and L. Yimin, "Average-based fuzzy time series models for forecasting Shanghai compound index",

- International Journal of Modelling and Simulation, Vol. 4, pp. 104-111, 2008.
- [7] V. Hejlová and V. Voženílek, “Wireless sensor network components for air pollution monitoring in the urban environment: Criteria and analysis for their selection”, Scientific Research : Wireless Sensor Network, Vol. 5, pp. 229-240, 2013.
- [8] A. Sherin, and L. Xinrong, “A cost-effective wireless sensor network system for indoor air quality monitoring applications”, International Journal of Computer Science Vol. 34, pp. 165-171, 2014.
- [9] P. Singh dan B. Borah, “An efficient time series forecasting model based on fuzzy time series”, International Journal of Engineering Applications of Artificial Intelligence, Vol. 26, pp. 2443–2457, 2013.