

Simple Resonant Power Converter Supplied by Photovoltaic for Ozonizer

Mochammad. Facta; Hermawan

Electrical Engineering Department, Universitas Diponegoro,
Semarang – Indonesia
facta@elektro.undip.ac.id

Zainal Salam

Universiti Teknologi Malaysia,
Skudai Johor – Malaysia

Abstract— Ozone gas (O₃) is widely used in deodorization, decolourization, disinfection, bleaching processes, gas/air treatment, chemical synthesis and recently in medical applications. Due the wide application of ozone then the ozone generator or ozonizer is urgently needed. A single switch resonant converter with ferrite transformer is proposed in this work. The prototype is constructed by two parts, first is ozone chamber and the second part is power converter with a single switch resonant converter and it supplied by photovoltaic simulator. The converter is successful to convert 12 volt from photovoltaic to 1.89 kV_{pp} high frequency voltage to ozone chamber. The ozone gas produce with the proposed system is 450 ppm with oxygen as an input gas.

Keywords— resonant converter, ozonizer; photovoltaic simulator.

I. INTRODUCTION

Conservative ozone generation with 50 or 60 Hz high voltage power supply, the voltage injected was about 3 – 10 kVrms or 8.5 – 28 kV peak to peak [1-3]. However, in practical the injected voltage used for ozone chamber at atmospheric pressure and ambient temperature is considerable high and near to the sparking potential. The dimension of conventional power supply is in a large volume, due to the present of transformer. Regard to safety, high voltage may not be suitable for household applications.

Recently, ozone generation with 50 or 60 Hz high voltage power supply, the voltage injected was about 3 – 10 kVrms or 8.5 – 28 kV peak to peak [1, 4, 5]. This results give an increase in ozone production for a given surface area, while decreasing the require peak voltage.

The the full bridge resonant converter operated at resonant frequency of 88 kHz was reported to generate ozone from from 4 – 6 kV peak to peak [6]. The converter requires four MOSFET switches and high DC input voltage (340 Volt). A single hard switching converter driving an ozone chamber filled with special discharge gas such as X_e, A_r, or N_e operated at certain pressure. The dielectric layer was constructed in borosilicate glass or quartz with a conductive thin layer on the surface. Although the voltage reduce to 1 kVrms or 2.8 kV peak to peak and the ozone yield was high, such chamber is considered complicated to construct. [4, 7].

Planar electrodes are made from metal with borosilicate glass as dielectric. This ozone chamber need to be operated at higher voltage (more than 7 kV) and frequencies from 5 - 7 kHz. [8-10]. Further more, the application of higher voltage result in filamentary effect inside the chamber [8, 11] and as a result a cooling system is necessary required.

A single switch resonant converter with ferrite transformer is proposed in this work. The prototype is constructed by two parts, first is ozone chamber and the second part is power converter with a single switch resonant converter and it supplied by photovoltaic simulator..

II. II. OZONIZER CHAMBER

The proposed ozone chamber is designed with simplicity and practically in mind. It is to be operated at atmospheric pressure and ambient temperature condition without the need to use special gas. In addition it requires no or water cooling. The geometrical configuration is a simple rectangular shape with a planar dielectric barrier, and the chamber is constructed in 70 x 140 mm square as shown in Figure 10. The chamber is constructed by aluminium mesh as electrode and metal tape with muscovite mica sheet as dielectric material are placed between the electrodes. The air gap inside chamber is 1.5 mm. Maximum operating temperature is about 500°C. A high voltage insulation tape is wrapped around the edges sides of electrode to prevent the spark or arch to occur [12].

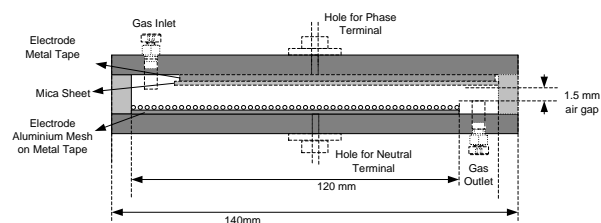

Figure 1. Ozone chamber

The investigation to the characteristics of the chamber as it is supplied by high voltage high frequency gives Lissajeux pattern. This pattern is shown in Figure 2. Due to this electrical characteristics, the equivalence circuit of the ozone chamber is represented in parallel capacitance and reactance [13] as it is shown in Figure 3.

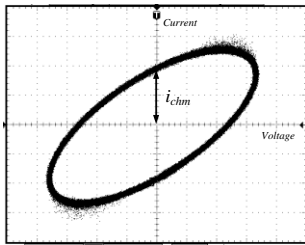

Figure 2. I-V characteristics in Lissajous Pattern

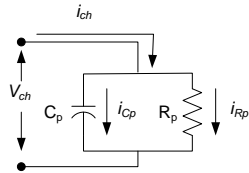

Figure 3. I-V Equivalent circuit of ozonizer

III. DESIGN OF SIMPLE RESONANT CONVERTER

The basic configuration of class E resonant converter connected to RC load is shown in Figure 4. The load is designed to achieve resonance condition at certain switching frequency. To increase the voltage by, a high voltage high frequency transformer is added as shown in Figure 5. It is normally constructed using ferrite core. The secondary winding of transformer (L_o) is included as part of the resonance tank. The RC load in the circuit represents of equivalent circuit of ozone chamber.

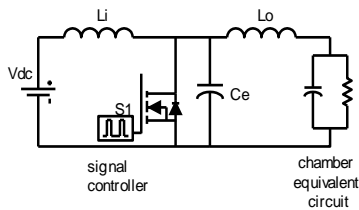

Figure 4. Fundamental Circuit of Single Switch Resonant Converter

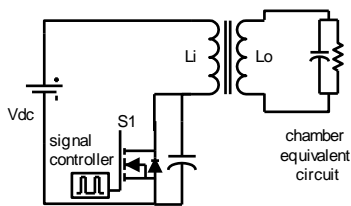

Figure 5. Single Switch Resonant Converter with step up transformer

The equivalent circuit when the switch is on and off are shown in Figure 6 (a) and (b) respectively. When the switch is on the capacitor C_e is short circuited by switch S_1 .

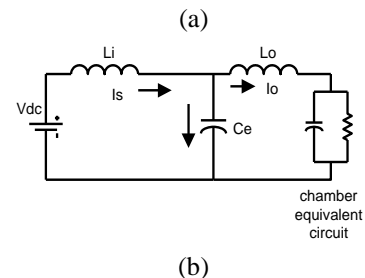
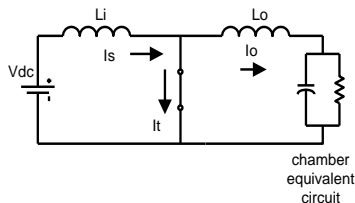

Figure 6. Single Switch Resonant Converter. (a) Switch turn on, (b) Switch turn off

The capacitor C_e will be charged and the switch voltage rises from zero to maximum and falls to zero again. When the switch voltage begins falling to zero, $I_C = C_e \frac{dv}{dt}$ normally will be negative. Thus, the switch voltage would tend to be negative. To limit this negative voltage, an anti parallel diode is connected and into switch (S_1). In practical this diode is already built in the switching component but in this purposed circuit, the switching device also has to withstand a high voltage.

A resonant circuit connected to simple resonant converter is similar with parallel loaded circuit in Figure 7. This resonant circuit is modeled from the secondary of transformer together with the equivalent model of ozonizer. This PLRC is able to deliver high voltage from lower voltage then the combination of this resonant circuit as AC part of single switch resonant converter.

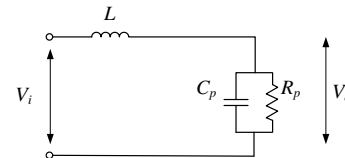

Figure 7. Equivalent Circuit of Ozone Chamber as part of Parallel Loaded Resonant Circuit

Theoretically, the parallel loaded circuit will gives voltage attenuation as Equation (1):

$$|G| = \frac{1}{\sqrt{(n^2 - 1)^2 + \left(\frac{n}{Q}\right)^2}} \quad (1)$$

where Q is quality factor, and n is the ratio between actual frequency and resonant frequency. Gain voltage as the function of frequency is illustrated in Figure 8. The maximum voltage is possible to achieve eight time of input voltage.

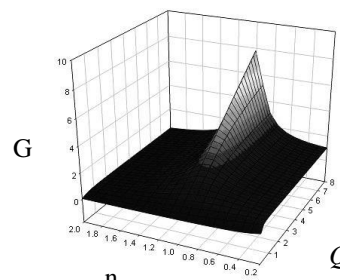

Figure 8. Gain voltage as the function of frequency

IV. PHOTOVOLTAIC MODULE SIMULATOR

The photovoltaic module simulator deliver power in the form of direct current according the the characteristic of photovoltaic which is programmed into the simulator. The characteristic of photovoltaic simulator is programmed to have 12 volt maximum power point (V_{mpp}) with 15.34 open circuit voltage (V_{oc}). The maximum short circuit current is 2.35 Ampere. The photovoltaic is possible to deliver maximum power at 25 Watt. Table 1 shows the characteristic of photovoltaic.

Table 1. The characteristic of photovoltaic

Power at mpp	25	Watt
Voltage at mpp	12	Volt
Current at mpp	2.0833	Ampere
Field Factor	68	%
Real Field Factor	69.26	%
Temp. V	-0.005	1/°C
Temp., I	0.0006	1/°C
Series resistance	0.01	Per unit
Parallel resistance	100	Per unit
Open Circuit Volt.	15.34	Volt
Short Circuit Volt.	2.35	Ampere

As the parameters in Table 1 is plotted then the curve characteristic of photovoltaic is shown Figure 9.

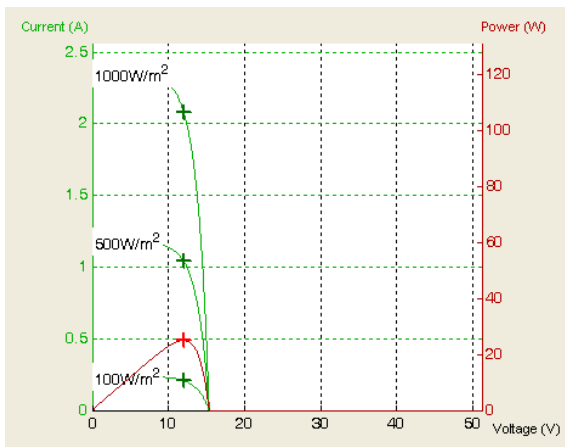

Figure 9. IV Curve of Photovoltaic

V. EXPERIMENTAL SETUP

The experimental setup of the complete ozonizer with simple resonant converter supplied by photovoltaic is shown in Fig. 9. An input gas was injected at 1 liter per minute, then the high frequency power supply was switched on. There are several input gas used in this work i.e. natural air, dry air and oxygen. The output gas or ozone is measured by ozone monitor and before the ozone is release to the aopen air then is must be flowed to ozone destructor. The power supply is a single switch high frequency resonant converter. It is modified from class E resonant power converter. There is no parasitic

capacitor at the high voltage side as in the conventional class E resonant converter because the chamber is already inherently capacitive. This inverter is operated in a frequency range of 27 kHz. To generate high frequency, a single MOSFET is controlled by pulsed width modulation integrated circuit (PWM IC). The gate drive opto coupler is connected to the MOSFET and PWM IC to amplify the control signal and provide electrical isolation. The inverter is supplied by Photovoltaic Module Simulator. To increase the voltage a step up ferrite transformer is connected between the inverter and the ozone chamber. The advantageous of this high frequency transformer is a small ferrite core size and much fewer windings.

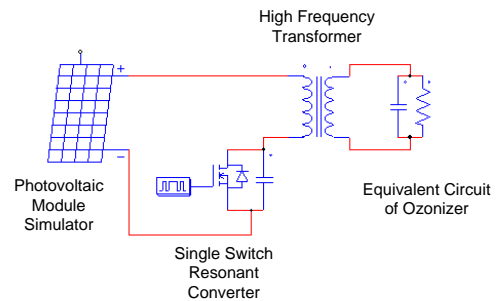

Figure 9. Experimental Set Up of ozonizer for Colour Removal

VI. RESULT AND DISCUSSION

At resonant frequency 27 kHz, the sinusoidal output voltage was obtained up to 1.89 kV_{p-p} as shown in Figure 10 (a), meanwhile the voltage at low voltage side is shown in Figure 10 (b). At voltage output, the spikes are easily seen and they indicate the electric discharges. The control signal of converter turn on and off at zero voltage in Figure . This operation indicate that the resonant converter work with zero voltage switching.

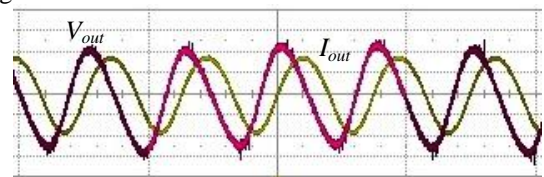

Figure 10.a Output voltage at terminal chamber Voltage (500V/div) and Current (20mA/div) at chamber side

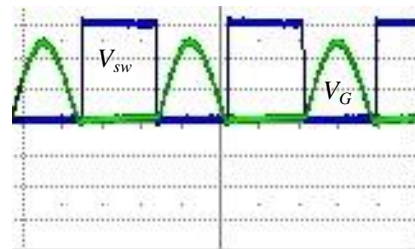

Figure 10.a Control signal , V_{sw} , (20 Volt/div) and voltage at low voltage side , V_G , (5V/div)

The result also shows that the circuit gives maximum ozone concentration 450 ppm or at 1.5 kV_{p-p}. as shown in Figure 11. The maximum ozone production is obtained when the input gas is oxygen.

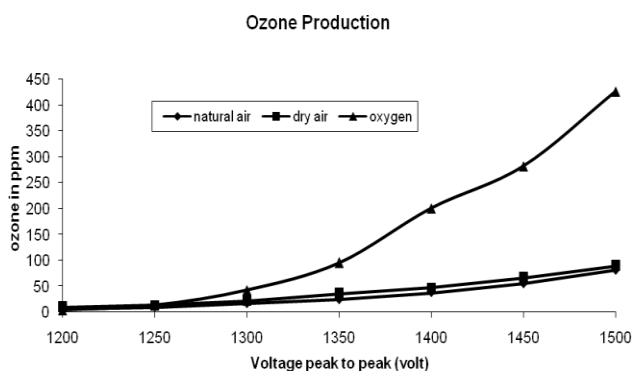

Figure 11. Ozone Concentration in ppm as a function of applied voltage in Volt

CONCLUSION

Based on the experimental result produced by the proposed simple resonant converter to generate ozone, several conclusion can be summarized as follow:

1. The ozonizer developed by simple resonant converter is successfully operated at atmospheric pressure and ambient temperature and produce amount of ozone.
2. The proposed simple resonant converter is successful to convert the power from photovoltaic simulator to generate high frequency and voltage to the ozone chamber
3. The use of simple resonant converter has been effectively magnify the dc input voltage 12 Volt from photovoltaic to 1.89 kV_{p-p}.
3. The ozone gas production with oxygen as an input gas has reach maximum result to deliver ozone in 450 ppm.

References

- [1] Kogelschatz. U. and B. Eliasson, "Ozone generation and application," ed New York: Marcel Dekker, 1995, pp. 581 – 605.
- [2] Alonso. J. Marcos, *et al.*, "High Frequency Testing and Modeling of Silent Discharge Ozone Generators," *Ozone: Science and Engineering*, vol. 25, p. 14, October 2003.
- [3] Mohammad A.T. Alsheyab and Aurelio H. Muñoz, "Optimisation of ozone production for water and wastewater treatment," *Desalination*, vol. 217, pp. 1-7, 2007.
- [4] Alonso. J. Marcos, *et al.*, "Analysis, Design, and Experimentation of a High-Voltage Power Supply for Ozone Generation Based on Current-Fed Parallel-Resonant Push-Pull Inverter," *IEEE transactions on industry applications* vol. 41, September/October 2005.
- [5] M. Facta, *et al.*, "Application of Resonant Converter in Ozone Generator Model," *Journal of Telkomnika*, vol. 6, pp. 33-38, 2008.
- [6] Nisoa. M., *et al.*, "Development of High Voltage High Frequency Resonant Inverter Power Supply for Atmospheric Surface Glow Barrier Discharges," *Solid State Phenomena*, vol. 17, pp. 81-85, 2005.
- [7] Alonso. J. Marcos, *et al.*, "Low-Power High-Voltage High-Frequency Power Supply for Ozone Generation," *IEEE Transaction on Industry Application*, vol. 40, March/April 2004.
- [8] Koudriavtsev. Oleg, *et al.*, "A Novel Pulse-Density-Modulated High-Frequency Inverter for Silent-Discharge-Type Ozonizer," *IEEE Transaction on Industry Application*, vol. 38, March/April 2002.
- [9] T. Fujishima, *et al.*, "Ozone and NO Generation Using High Frequency Dielectric Barrier Discharge," presented at the the XIVth International Symposium on High Voltage Engineering, Tsinghua University, Beijing, Cina, 2005.
- [10] Jitsomboonmit, *et al.*, "Design of high voltage medium frequency power supply for plasma application," presented at the 33rd Congress On Science & Technology of Thailand, 2006.
- [11] Buntat. Zolkafle, *et al.*, "Ozone generation using atmospheric pressure glow discharge in air," *J. Phys. D: Appl. Phys.*, vol. 42, p. 5, 2009.
- [12] M. Facta, *et al.*, "A New Type of Planar Chamber for High Frequency Ozone Generator System," *Advanced Materials Research* vol. Vol. 896 pp. 726-729, 2014.
- [13] M. P. Silva, *et al.*, "Single Switch Power Supply based on the Class E Shunt Amplifier for Ozone Generator," presented at the 38th Power Electronics Specialist Conference, Florida, USA, 2007.