

# Switched Beam Smart Antenna for Wireless Local Area Network

Evizal, Sri Listia Rosa

Sekolah Tinggi Teknologi Pelalawan  
Jl. Maharaja Indra No. 379, Pangkalan Kerinci, 28300  
Pelalawan Riau Indonesia  
e-mail : [evizal@gmail.com](mailto:evizal@gmail.com), [srilistia@gmail.com](mailto:srilistia@gmail.com)

Eko Supriyanto

Department of Clinical Science and Engineering,  
Faculty of Health Science and Biomedical Engineering,  
Universiti Teknologi Malaysia, 81310 Johor, Malaysia  
e-mail : [eko@biomedical.utm.my](mailto:eko@biomedical.utm.my)

Tharek Abd Rahman, Sharul Kamal Abdul Rahim

and Ali Moradikordalivand  
Wireless Communication Centre,  
Faculty of Electrical Engineering  
Universiti Teknologi Malaysia, 81310 Johor Malaysia  
e-mail : [tharek@fke.utm.my](mailto:tharek@fke.utm.my), [sharulkamal@fke.utm.my](mailto:sharulkamal@fke.utm.my),  
[alimoradi2020@gmail.com](mailto:alimoradi2020@gmail.com)

**Abstract**—In wireless communication system, interference is one of the issue facing that can disturb in communicating between base station and mobile devices. This paper propose switched beam smart antenna system, an octagonal configuration of directional antenna is introduced and selecting beam to desire user. Each beam of antenna covered 45 degrees; by assembly of all directional antennas to create an omni-directional configuration with coverage all the beam 360 degrees. To control of the beam switching, an inexpensive microcontroller PIC 16F877 from microchip used, radio signal strength of mobile device receive as reference signal and compare to each of beam, the highest signal received is selected than microcontroller will lock to the desire beam. A few samples of received signal strength to be analysis by an algorithm to avoid multiple signals and select actual signal strength received. In this experiment 2.45 GHz ISM band used for the transmitter and receiver and testing have been conducted in outdoor environment. Results shows that switched beam smart antenna working fine base on mobile device location and able to switch the beam while mobile device is moving.

**Keywords**— *Smart antenna, switched beam, microstrip, microcontroller*

## I. INTRODUCTION

Telecommunication is a way to communicate between people in this era, radio communication is one of model telecommunication system that used radio frequency as media and in a few decades, radios communication has rapid changing in term of hardware and capabilities. The used of radio communication for transmit or received voice, data, image and video. Currently Mobile communication or in other hand is wireless communication apply in most of area such as industrial, transportation, education, communication system, etc. Rapid growing of user and application using wireless system and limited of resources spectrum radio frequency, some challenging to improve and design efficient system is needed. The used of radio frequency in communication system also facing some issues such as interference, efficiency of system, quality of service and data rate.

Smart antenna is a systems consist of a few set of single antenna that create array system, with a digital signal processing that capability to transmit and receive in an adaptive and spatially sensitive manner [1-3]. Each antenna has individual beam zone based on antenna design and by arranging, a few of antennas to increase covered area to all beam in 360 degrees. There are two types of common smart antenna system, namely switch beam and adaptive array system. Switch beam smart antenna require simple processing system and algorithm in order to switch the beam to desire user, else adaptive array smart antenna require more intelligent in algorithm, signal processing and complex of system. Refer to the concept of how smart antenna working, it's has ability to overcome some of current issues in wireless communication as mention previously.

Various research on smart antenna has been explore by previous researches, switch beam smart antenna system is one technique that explored, reconfiguration of single antenna and apply of beam forming concept to switch beam antenna as reported in [4-11], another method of switch beam proposed is explored on algorithm and simulation as reported in [12-15]. Refer to the previous research that has been explorer, many things have been done commonly configuration of single antenna for beam forming and apply beam forming concept for switching beam. Some of others are implement simulation for smart antenna and apply algorithm for intelligent and smoothness switch beam.

In this paper proposed and explore alternative solution, inexpensive switching beam used PIC 16F877 microcontroller to control beam of antenna to desire beam of mobile device. Proposed concept is uncomplicated, where received signal strength from mobile device to be analysis by simple algorithm and desire to one of beam with highest signal strength. An algorithm has implemented to this smart antenna system in order to process the signal strength and to get accurate result.

## II. SWITCHED BEAM SMART ANTENNA

Smart antenna is an antenna array with a control system and digital signal processing for advanced and intelligent controller. A smart antenna system is a method used in wireless communications to locate mobile device (user) which is capable of directing its beam radiation to a particular user or direction. Nowadays, smart antenna technology with improvement in designing offers a significantly solution to overcome some issues such as interference levels, improve system capacity and efficiency. In this technology, every signal come from users or mobile device is transmitted and received by the base station only in the direction of that particular user, this method of transmission and reception is called beam forming and is made possible through smart (advanced) signal processing at the baseband.

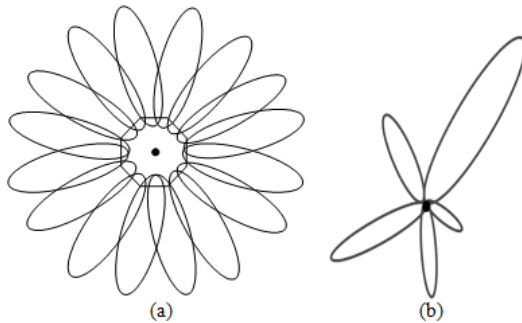


Fig. 1. Basic concept of smart antenna (a) switch beam (b) adaptive array.

There are two types of smart antenna commonly used which is switching beam smart antenna and adaptive array (more intelligent). Switch beam or switch lobe is a simplest, comprises of only a basic switching function between separate directive antennas or predefined beams of an array and the setting that gives the best performance is chosen. Where, adaptive array is an antenna system complete with directional of arrival signal algorithm for determining the direction toward interference sources and the radiation pattern can then be adjusted to null out the interferers. Figure 1 shows basic concept of two different smart antenna systems, where Figure 1a an antenna consist of multiple fixed beams that can be switch to desired particular beam as controlled by system and Figure 1b an adaptive array antenna that more intelligent system. Both of system has same objective which is to forward the beam of antenna to one or desired user, but in adaptive array more efficient and effective system because by suppressing unwanted beam.

In the smart antenna system, angle of arrival (AOA) also know as direction of arrival (DOA) is one of factor determine precise of calculation receipt signal from mobile station. A few techniques and algorithm to calculate and estimation of angle of arrival signal from the mobile device. Figure 2 shows a receive signals arriving from  $N$  directions and  $N$  number of angle of arrival, number of received by an array antenna of  $M$  elements with  $M$  potential weights. Every received signal of  $x_M(k)$  includes additive, zero mean and Gaussian noise will calculate. The number of time  $k$ th is represented sample of time, thus summary of array output antenna of  $y(k)$  can be writing as below formula:

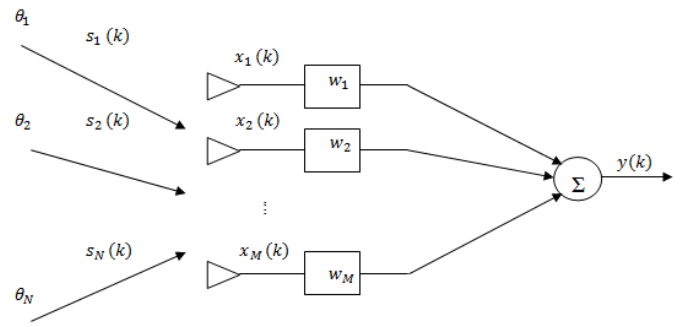


Fig. 2. M-number of array antenna with signal arrival.

$$y(k) = w^{-T} \cdot \bar{x}(k) \tag{1}$$

where,

$$\bar{x}(k) = [\bar{a}(\theta_1) \quad \bar{a}(\theta_2) \quad \dots \quad \bar{a}(\theta_N)] \cdot \begin{bmatrix} s_1(k) \\ s_2(k) \\ \vdots \\ s_N(k) \end{bmatrix} + \bar{n}(k) \tag{2}$$

$$= \bar{A} \cdot \bar{s}(k) + \bar{n}(k)$$

and

$\bar{w} = [w_1 \ w_2 \ \dots \ w_M]^T$  = weight of array antenna  
 $\bar{s}(k)$  = vector of incident complex monochromatic signal at time  $k$   
 $\bar{n}(k)$  = noise vector at each array element  $m$ , zero mean, variance  $\sigma_n^2$   
 $\bar{a}(\theta_i)$  =  $M$ -element array steering vector for the  $\theta_i$  direction of arrival  
 $\bar{A} = [\bar{a}(\theta_1) \ \bar{a}(\theta_2) \ \dots \ \bar{a}(\theta_N)]$   $M \times D$  matrix of steering vector  $\bar{a}(\theta_i)$

Number of radiation pattern of a typical element antenna array can be changed or design by determine number of antenna installed. Higher numbers of array element of antenna will obtain narrower beam radiation pattern and complexity of signal processing is required because more element beam of antenna need to calculate, similar by changing relative phase excitation, the orientation of radiation pattern will changed. Every of the  $N$ -complex signals arriving from various angles  $\theta_i$  and is intercepted by others of the  $M$  antenna elements, number of arriving signal  $N$  normally less than number of array antenna  $M$ . Equation (1) represent of summary of signal arriving from  $M$  element of antenna and Equation (2) represent of number of  $\bar{x}(k)$  element antenna, where vector of arrival signal at time  $k$  to number of  $M$ -element angle of arrival antenna. The contains of steering vector to response of all elements of the array antenna to a narrow-band source of power received. As the response of the array is different directions between each others, a steering vector is associated with each directional source [2].

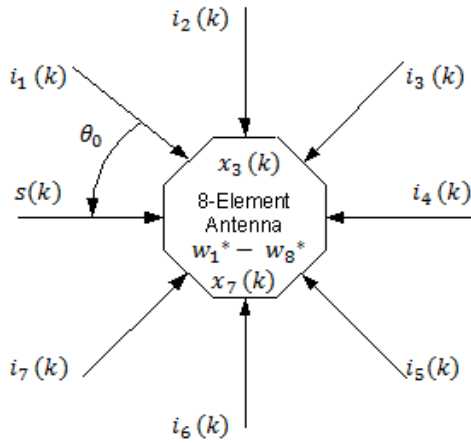


Fig. 3. An 8-element of proposed switch beam smart antenna.

The proposed switch beam smart antenna consist of eight sector elements (octagonal structure), the elements form of omni-direction which is each element cover of 45 degrees. Figure 3 shows 8-elements of antenna that covering omni-directional is 360 degrees, each element desired one signal arriving from the angle of  $\theta_1$  and others interference arriving signal  $\theta_2$  to  $\theta_8$ . Antenna will beam to desired particular user that highest received signal and controlled by simple switching system.

As shows in Figure 3, a desired signal arrival is  $s(k)$  to the first element of array antenna  $x_1(k)$  with the angle is  $\theta_0$ , number of interference signal is  $i_1(k) - i_7(k)$ . 8-element of array antenna from  $w_1^* - w_8^*$  with the 8 potential weights, the array output  $y(k)$  can be calculated as:

$$y(k) = w^{-H} \cdot \bar{x}(k) \tag{3}$$

where,

$$\begin{aligned} \bar{x}(k) &= \bar{a}_0 s(k) + [\bar{a}_1 + \bar{a}_2 + \bar{a}_3 + \bar{a}_4 + \bar{a}_5 + \bar{a}_6 + \\ &\quad \bar{a}_7] \begin{bmatrix} i_1(k) \\ i_2(k) \\ i_3(k) \\ i_4(k) \\ i_5(k) \\ i_6(k) \\ i_7(k) \end{bmatrix} + \bar{n}(k) \tag{4} \\ &= \bar{x}_s(k) + \bar{x}_i(k) + \bar{n}(k) \end{aligned}$$

and

$$\bar{w} = [w_1 \ w_2 \ w_3 \ w_4 \ w_5 \ w_6 \ w_7 \ w_8]^T$$

= weight of array antenna

$\bar{x}_s(k)$  = desired signal vector arrival

$\bar{x}_i(k)$  = signal vector interference

$\bar{n}(k)$  = zero mean Gaussian noise for each element of antenna

$\bar{a}_i$  = M-element of array antenna steering vector for the  $\theta_i$  direction of arrival

Equations (3) and (4) above can be rewrite to get array output of smart antenna  $y(k)$  as Eq. 5 below:

$$\begin{aligned} y(k) &= w^{-H} \cdot [\bar{x}_s(k) + \bar{x}_i(k) + \bar{n}(k)] \\ &= w^{-H} \cdot [\bar{x}_s(k) + \bar{u}(k)] \tag{5} \end{aligned}$$

where,

$$\bar{u}(k) = \bar{x}_i(k) + \bar{n}(k) = \text{undesired signal arrival}$$

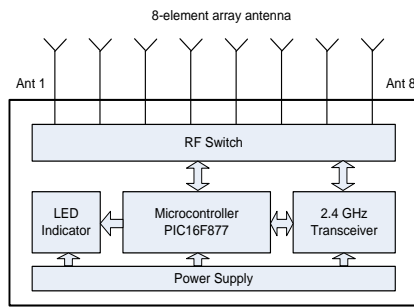
### III. ANTENNA DESIGN AND PROTOTYPE

The design of switch beam smart antenna started by design each single element of array antenna; proposed frequency band in this antenna is 2.45 GHz ISM band thus the prototype of smart antenna system designed in that frequency, similar to transmitter and receiver used in the system. Basic design of single array antenna is microstrip type [16], where using inexpensive material available in the market, the proposed antenna is fabricated using FR4 material with relative permittivity of  $\epsilon_r = 4.7$ , height  $h = 1.6$  mm and  $\tan \delta = 0.019$ . Figure 4 shows fabricated of single element of array antenna with directional direction and beam width is 50 degrees.

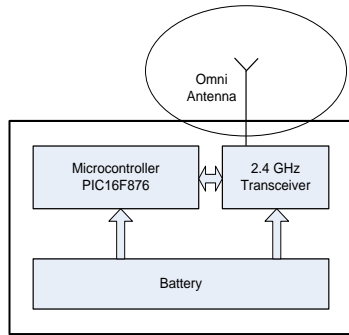


Fig. 4. Single element of array antenna.

As mentioned previously, the proposed switched beam smart antenna is in octagonal configuration which is consists of 8-element single array antenna. Figure 5 shows basic block diagram of smart antenna system, while Figure 5a block diagram for base station and 5b block diagram for mobile device with antenna direction is Omni-directional. Microcontroller PIC 16F877 is used for base station to control the beam of selected antenna and PIC 16F876 used for mobile station to store some data and controlling transmitter station [17]. A simple processing is implemented in the controller system to select which is desired beam and monitoring movement of mobile device. A 2.4 GHz transceiver is used for the base station and mobile device, in this case X-Bee module used as prototype for transmitting and receiving sample data from mobile device. Mobile device power supply used a Ni-Cad battery to supply for both microcontroller and transceiver module.



(a)



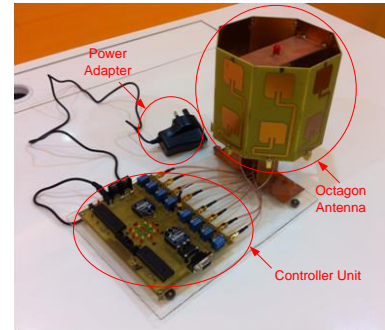
(b)

Fig. 5. Basic block diagram switch beam smart antenna (a) base station (b) mobile device.

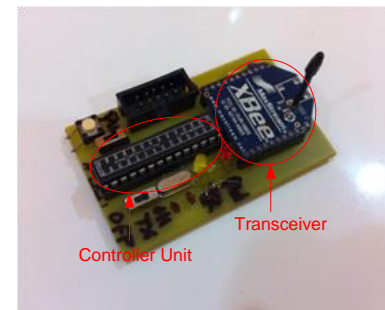
Radio signal strength indicator (RSSI) sends from mobile device by microcontroller used as reference to be analysis and define in which angle of highest signal came. In common of wireless communication system path loss or multi path is one of the issue and base station received many signals from different angle, this is happen in actual scenario. To make intelligent system, a few sample of RSSI received by base station is analysis by algorithm in processing to determine actual value of signal strength, selected signal strength value stored and use as reference for define beam switching. Once system detected actual signal value and from which angle of mobile device than system will switch the beam to an element of array antenna to desired user. 8 units of magnetic relay used to switch the beam of each single antenna, by considering internal impedance of every relay is same and also losses to each array antenna than system did not used standard RF switch for switching system, as this prototype to proof that concept switch beam of smart antenna is working.

In the prototype also installed LED as indicator for desired beam switching by system, mean actual desired direction beam of antenna shows in LED indicator. While user is moving from an angle of direction to other angle, system keep checking data and radio signal received than compare to current signal received, if any changes with system will define and switch to the new angle of beam. Figure 6 shows a fabricated prototype of smart antenna system, where Figure 6a Base station unit complete with microcontroller and between antenna units to controller feed by 50 ohm coaxial cable and SMAs connector. Figure 6b shows a prototype of mobile device, a unit of X-Bee module used as transceiver in frequency 2.45 GHz ISM band, as mention in previous discussion a transceiver and

microcontroller used for transmits and receives data. When a mobile device is set to active than device keep transmitting packet of data included of RSSI that will receive by the base station.



(a)



(b)

Fig. 6. Prototype of smart antenna system (a) base station (b) mobile device.

Figure 7 shows detail of component in controller unit used, X-bee module use for transmit and receive packet of data from mobile device, where in a packet of data received consist of a block of RSSI data that can be used as reference for signal strength. Signal strength of mobile device than use for reference to define location or direction. A set of controllers used to control all the process than define in which beam to switch of antenna. While 8 units magnetic relay used to switch the beam and each relay represent each beam of antenna and once system define in which beam to select than LED indicator (star configuration) will show the direction of mobile device. A communication port RS 232 preferred that make system able communicate to PC or laptop for data logging.

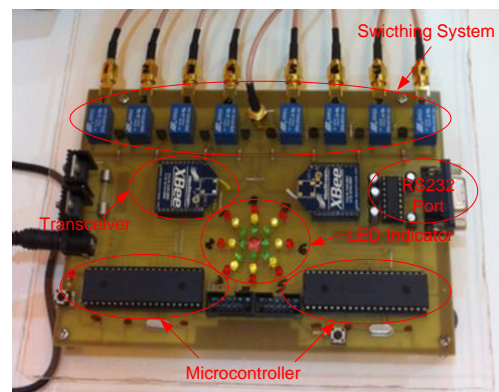


Fig. 7. Controller unit of smart antenna.



### A. Antenna Measurement Setup

The single array antenna assembled in octagonal structure with 8-elements to cover all of angle in 360 degrees, to check the performance of radiation pattern every single angle of antenna, thus a measurement is needed. Figure 8 shows a measurement setup in anechoic chamber room of 8-elements single antenna, in this measurement all beams of single antenna measured to conform of every beams are similar radiation pattern. A transmitter with center frequency 2.45 GHz is used in this setup of measurement in anechoic chamber and a set receiver as same frequency connected to a computer system to plot automatic radiation pattern of measured results. Measurement done for the entire beam started from beam 1 to beam 8, although structure of all antennas is same but to proof all of beams direction has similar radiation pattern. The ground of each single antenna while assembled are connected to each other's and make the ground elements is become larger, the results on radiation pattern response will discuss in next section.

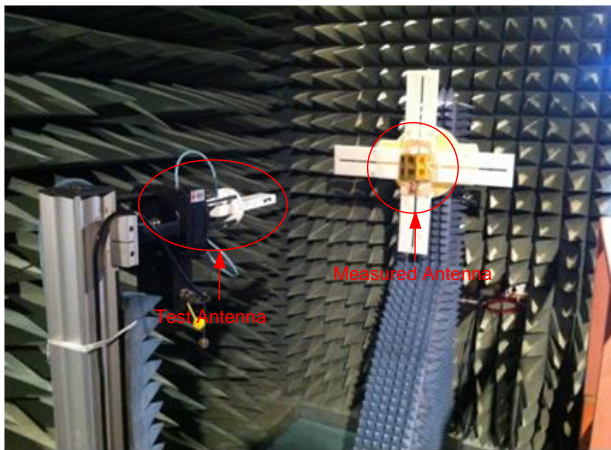


Fig. 8. Measurement of radiation pattern of antenna in anechoic chamber.

Figure 9 shows a testing that have been done at actual field in parking area, where a mobile device (user) place at one of antenna angle than smart antenna system desired a particular beam. First testing scenario conducted by placing mobile device at one of the beam direction, in this test distance between base station and mobile device set to 5 meters, where all the received signal strength values by the base station recorded. Similar to others seven direction of beams, do same distance and angle than record all the received signal values to be compare each others. Second scenario is by placing mobile device at the center angle of each beam direction for example 0 degrees for beam 1 and 90 degrees for beam 3 and so on.

Represented angle of each beam direction indicate by LED indicator at the module unit. Some movement of user tested to see the system able to scan movement and switch to desired angle beam of user. In this testing the environment is outdoors, there are multi signals received by system because of path and reflected signal from the object around. As mention in previous, every beam take references signal strength is 10 numbers and calculate the average signal value as reference.



Fig. 9. Field testing of smart antenna system.

In results, testing in outdoor system able to switch the beam as desired user location but in case many of reflected signal sometime miss of actual value of reading, the complete result and value of received signal strength as show in result below. In the processing flow, there is stored RSSI value for the learning process, this mean every process of received signal were stored and record for pattern behavior and as much as possible for learning process, a system become intelligent and can be refer to the previous behavior of signal once learning process is complete.

### IV. RESULTS AND DISCUSSION

The simulated result of single array antenna as shows in Figure 10, value of reflection coefficient parameter of single band antenna is -40.3 dB at operating frequency of 2.45 GHz, while the measurement value is -21.7 dB. Bandwidth of single antenna covered for the ISM band 2.4 GHz which is 2.40 GHz – 2.483 GHz. This single antenna proposed for array of switch beam antenna system and octagonal structural to cover omnidirectional.

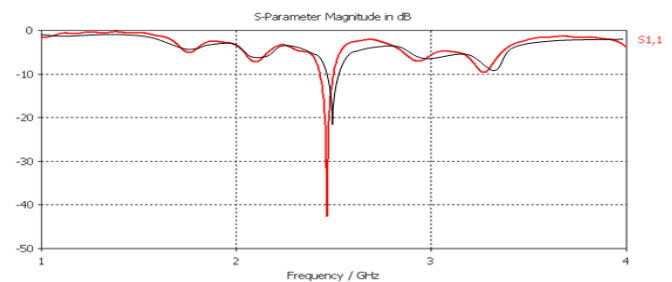


Fig. 10. Reflection coefficient of single array antenna.

Simulation results of antenna radiation pattern as shows in Figure 11 below, where the polar radiation patterns of octagon structure 8-elements of smart antenna operating at a frequency of 2.45 GHz. Results shows the 3dB beamwidth of antenna is 50 degrees that a bit wider compare to the requirement of proposed smart antenna system. The octagonal configuration required minimum is 45 degrees for each antenna to cover all 360 degrees, that mean the single proposed antenna fulfil for the array configuration.

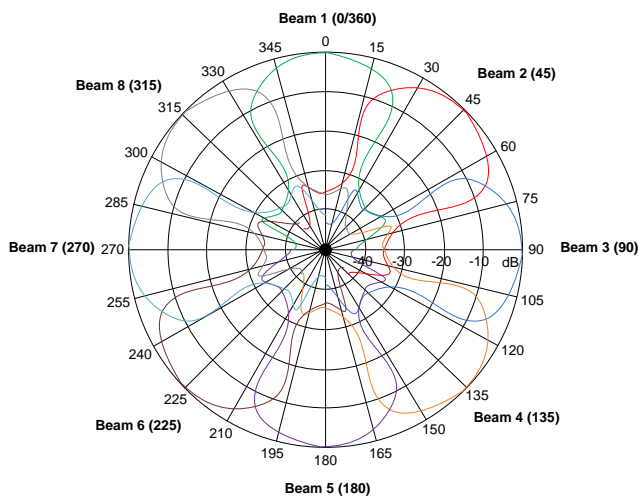


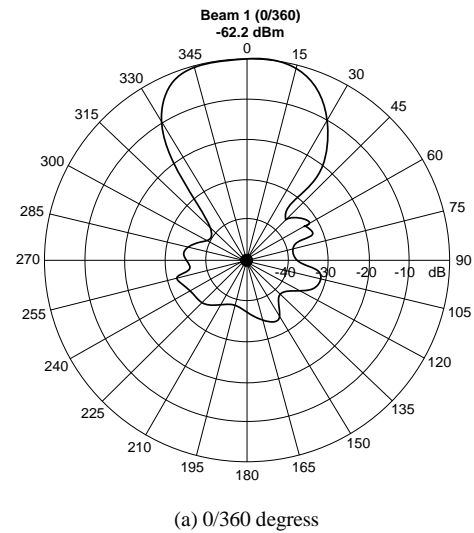
Fig. 11. Simulation radiation pattern 8-elements of antenna.

There is a radiation and some ripple at the back lobe, refer to the value of that ripple is not much effected to the performance of antenna since in overall single antenna were attached to array. Results also show each beam direction of antenna have similar response, this because of each antenna has same design. Sharing ground element of every single antenna also not much affected to the performance of radiation pattern. In overall, if all results plotted in a chart there is overlapping radiation between each antenna to others and the angle of overlapping is not significantly.

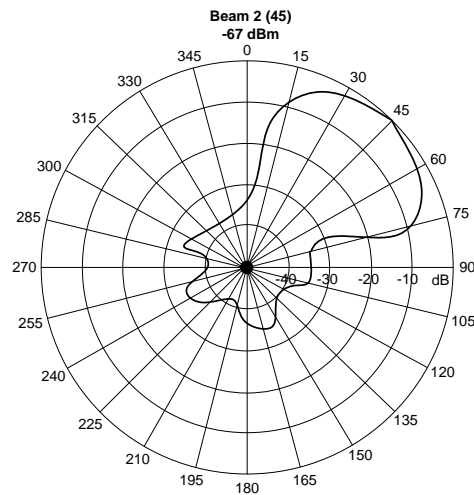
TABLE 1. NUMBER OF RSSI DATA COLLECTED AND AVERAGE VALUE OF SIGNAL IN 0 DEGREES POSITION.

Number of RSSI Collected	RSSI Value (dBm)							
	Beam 1	Beam 2	Beam 3	Beam 4	Beam 5	Beam 6	Beam 7	Beam 8
1	-63	-73	-85	-93	-99	-90	-81	-71
2	-61	-70	-85	-95	-100	-93	-81	-73
3	-63	-73	-83	-91	-103	-90	-81	-73
4	-63	-75	-85	-90	-98	-93	-85	-75
5	-60	-73	-80	-93	-99	-95	-83	-74
6	-61	-71	-86	-91	-99	-95	-83	-73
7	-63	-73	-85	-93	-100	-90	-80	-73
8	-64	-75	-83	-95	-99	-90	-83	-71
9	-65	-71	-85	-93	-98	-93	-83	-70
10	-63	-73	-85	-93	-99	-92	-81	-73
<b>Average RSSI</b>	<b>-62.6</b>	<b>-72.7</b>	<b>-84.2</b>	<b>-92.7</b>	<b>-99.4</b>	<b>-92.1</b>	<b>-82.1</b>	<b>-72.6</b>

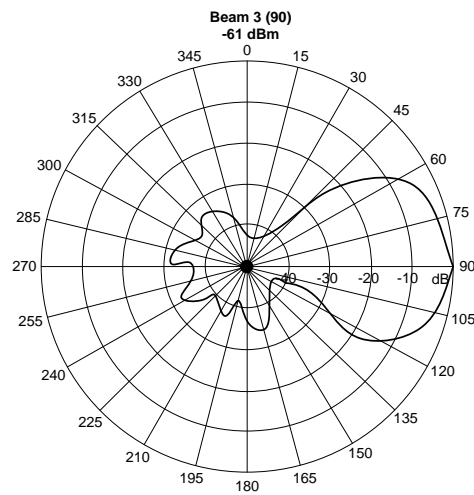
Results of signal strength value collected from every beams of direction is as shown in Table 1 above, where mobile device is placed at the one of beam direction, in this case is at 0 degrees position. Values of signal for second beam direction to eighth beam direction is collected and recorded. The octagon structure with 8-elements of antennas has symmetrical angle, thus the value of signal for those beam is similar, for example values of second beam and eighth beam or third beam and seventh beam. Every beam of direction collected with 10 samples data of signal strength and calculates the average values of the signal as reference in processing to define actual signal of represented beam. These values of signal compare to others beam direction to select which is highest value as angle of direction arrival signal.



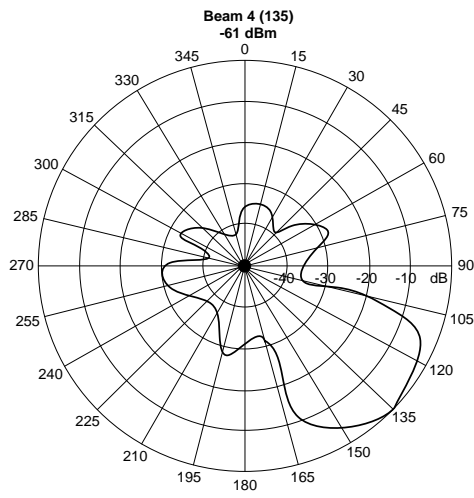
(a) 0/360 degree



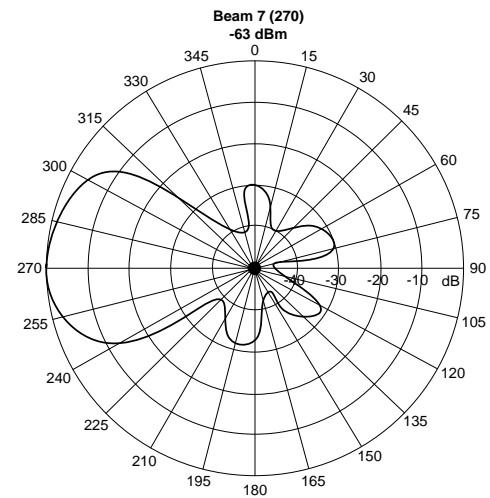
(b) 45 degree



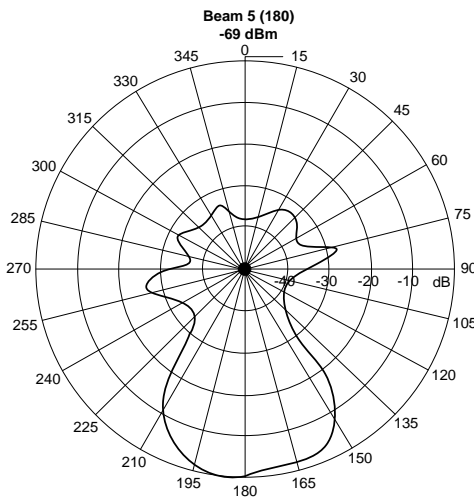
(c) 90 degree



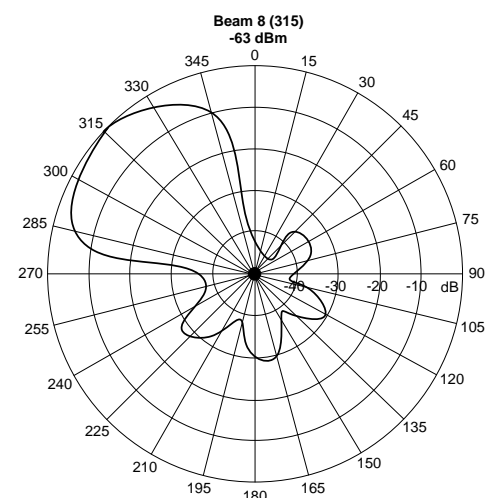
(d) 135 degree



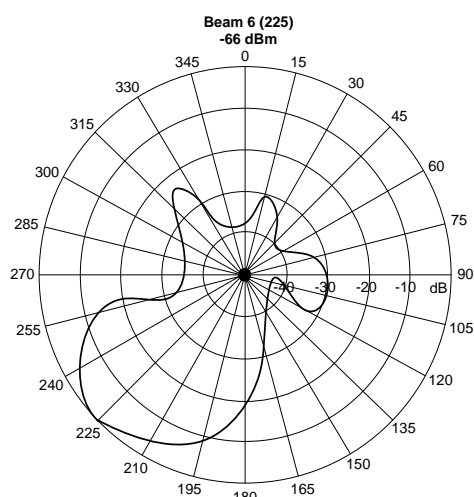
(g) 270 degree



(e) 180 degree



(h) 315 degree



(f) 225 degree

Fig. 12. Measurement of radiation pattern 8-elements of antenna(a) 0/360 degrees (b) 45 degrees (c) 90 degrees (d) 135 degrees (e) 180 degrees (f) 225 degrees (g) 270 degrees (h)315 degree.

Figure 12 shows the measurement results of radiation pattern smart antenna system in each angle of beam, starting from Figure 12a for 0/360, Figure 12b for 45 degrees, Figure 12c for 90 degrees, Figure 12d for 135 degrees, Figure 12e for 180 degrees, Figure 12f for 225 degrees, Figure 12g for 270 degrees and Figure 12h for 315 degrees. Result shows of every angle of beam with average beam width is 45-55 degrees. The result is under proposed covered area of beam as mention early; in this smart antenna system beamwidth is required narrow as configuration because wide beam will create higher possibility interference to others beam of antenna.

Table 2 shows results of signal strength values collected while mobile device placed at every beam of direction than recorded signal strength received by others beam. Started from first beam which is 0 degrees, all the signal received values by the base station is recorded until the last beam is 315 degrees. In this testing as mention above distance of mobile device to

base station set to 5 meters, the purpose is to check the values and compare every beam to each others. The high value is supposed belong to the direction of beam where mobile device placed and the lowest is at the back lobe of antenna. Highest values of signal received is -61 dBm as in table and the lowest is -101 where the beam is backward of mobile device. The highest value is represented where the actual angle comes from and microcontroller system used this value of signal to switch the beam of antenna to define angle of user beam.

TABLE 2. VALUE OF RSSI RECEIVED IN BEAM 1ST TO BEAM 8TH.

Mobile Device Location (degrees)	RSSI Value (dBm)							
	Beam 1	Beam 2	Beam 3	Beam 4	Beam 5	Beam 6	Beam 7	Beam 8
0	-63	-73	-85	-94	-101	-92	-80	-75
45	-71	-67	-73	-82	-95	-98	-95	-82
90	-83	-75	-61	-70	-80	-91	-100	-93
135	-95	-80	-75	-61	-73	-83	-92	-99
180	-98	-93	-84	-71	-69	-71	-83	-90
225	-92	-100	-93	-83	-72	-66	-72	-85
270	-85	-91	-100	-90	-84	-75	-63	-73
315	-73	-83	-95	-98	-95	-85	-70	-63

V. CONCLUSION

A switched beam smart antenna system for mobile communication as proposed has been simulated, measured and tested. The proposed antenna fabricated used FR4 material; prototype system used PIC 16F877 microcontroller for base station and 16F876 microcontroller for mobile device. Smart antenna system design used frequency band 2.45 GHz ISM for transmitter and receiver, in this case used X-Bee module that working at 2.45 GHz frequency. Structure of antenna is divide by 8-elements (octagonal) which mean every element cover for the 45 degrees, the antenna with octagonal structure have been measured in radiation pattern. Complete set of prototype smart antenna with control unit also tested in anechoic chamber room to check the performance, while mobile device is moving around the radiation area of antenna. The antenna system used radio signal strength RSSI as reference in data processing, method used such collect some signal strength as reference and analysis by implement simple algorithm and also used learning concept for the past behaviour of data. There is need some advanced and continue research for multiple users for this inexpensive prototype of smart antenna system, with this system potentially apply to mobile communication system.

ACKNOWLEDGMENT

This project supported by Sekolah Tinggi Teknologi Pelalawan (ST2P) Pangkalan Kerinci, Pelalawan Riau Indonesia.

REFERENCES

[1] A. E. Zooghyby, *Smart Antenna Engineering*. Massachusetts: Artech House, Inc., 2005.  
 [2] F. B. Gross, *Smart Antenna for Wireless Communication*. United States: McGraw-Hill, 2005.

[3] M. C. W. T. K. Sarkar, M. Salazar-Palma, Robert J. Bonneau, *Smart Antenna*. New Jersey: John Wiley & Sons, 2005.  
 [4] K. H. K. W. Kang, and K. Kim, "A compact beam reconfigurable antenna for symmetric beam switching," *Progress In Electromagnetics Research*, vol. 129, pp. 1-16, 2012.  
 [5] W. Han, *et al.*, "A Beam-Switching Antenna Array With Shaped Radiation Patterns," *Antennas and Wireless Propagation Letters, IEEE*, vol. 11, pp. 818-821, 2012.  
 [6] J. R. De Luis and F. De Flaviis, "Frequency Agile Switched Beam Antenna Array System," *Antennas and Propagation, IEEE Transactions on*, vol. 58, pp. 3196-3204, 2010.  
 [7] K. A. Gotsis, *et al.*, "On the Direction of Arrival (DoA) Estimation for a Switched-Beam Antenna System Using Neural Networks," *Antennas and Propagation, IEEE Transactions on*, vol. 57, pp. 1399-1411, 2009.  
 [8] D. W. P. Wounchoum, C. Phongcharoenpanich, and M. Krairiksh, "A switched-beam antenna using circumferential-slots on a concentric sectoral cylindrical cavity excited by coupling slots," *Progress In Electromagnetics Research*, vol. 120, pp. 127-141, 2011.  
 [9] P. S. H. M. R. B. Kamarudin, F. Colombel, and M. Himdi, "Electronically switched beam disk-loaded monopole array antenna," *Progress In Electromagnetics Research*, vol. 101, pp. 339-347, 2010.  
 [10] H. Ming-Ju, *et al.*, "Performance of switched-beam smart antennas for cellular radio systems,"  *Vehicular Technology, IEEE Transactions on*, vol. 47, pp. 10-19, 1998.  
 [11] W. Z. Han, Zhang; Zhenghe, Feng, "A Beam-Switching Antenna Array With Shaped Radiation Patterns," *Antennas and Wireless Propagation Letters, IEEE*, vol. 11, pp. 818-821, 2012.  
 [12] G. R. D. F. Gozasht, and S. Nikmhr, "A comprehensive performance study of circular and hexagonal array geometreis in the lms algorithm for smart antenna applications," *Progress In Electromagnetics Research*, vol. 68, pp. 281-296, 2007.  
 [13] C. G. Christodoulou, *et al.*, "Reconfigurable Antennas for Wireless and Space Applications," *Proceedings of the IEEE*, vol. 100, pp. 2250-2261, 2012.  
 [14] T. Ngamjaroen, *et al.*, "Performance of non co-phase EGC diversity technique with multiple antennas on limited space," *Transactions on Electrical Engineering, Electronics, and Communications*, vol. 9, pp. 75-82, 2011.  
 [15] S. Makwimanloy, *et al.*, "A novel anti-collision algorithm for high-density RFID tags," *Transactions on Electrical Engineering, Electronics, and Communications*, vol. 9, pp. 33-39, 2011.  
 [16] C. A. Balanis, *Antenna Theory: Analysis and Design*: John Wiley & Sons, 2005.  
 [17] M. T. Inc. (2003, *PIC16F87XA Data Sheet*. Available: <http://www.microchip.com>