



Proceeding of the International Conference on Advanced Science, Engineering and Information Technology 2011

Hotel Equatorial Bangi-Putrajaya, Malaysia, 14 - 15 January 2011

ISBN 978-983-42366-4-9



Measurement of Forces and Torques during Penetration on Homogeneous Material Drilling Operation

Mohd Hazny Aziz[#], Muhammad Azmi Ayub^{*}

[#] Faculty Mechanical of Engineering, University Institute Technology of Mara

Universiti Teknologi MARA (UiTM), Shah Alam, 40450, Malaysia

Tel.: +603-55436295, E-mail: hazny.aziz@gmail.com

Abstract— The purpose of this study is to measure the forces and torques that produce in the drilling process of non-homogeneous material (bone). An automated five degree of freedom CRS CataLyst-5 robot used during the drilling process together with the six degree freedom of force torque sensor. A force torque controller that built in Matlab Simulink environment is used to control the drilling process of the robot. Different feed rate will be used during the experimental of the drilling process. The sensors will be calibrated and will measure the tri axial direction of resultant forces and torques. The profiles of the forces and torques graphs that obtained are non-linear since the diversity of density of bone.

Keywords— Bone drilling, CRS CataLyst-5 robot, Matlab Simulink environment.

I. INTRODUCTION

An orthopedic surgery for bone involves drilling, milling, sawing and reaming. The drilling process of bone will produce forces and torques. The forces and torques can be calibrated or measured using a force torque sensor. As presented in [1] the researcher used a bi-directional force sensor during the experimental test and Wen-Yo Lee *et al.* [2] did an experimental set up for drilling porcine bone that used a thrust-force sensor and a drilling motor torque sensor. A spinal fusion surgery that used robotic assistant with drill wire [3] also employed a (ATI automation model Nano 17) six degree of freedom force sensor to measure force when drilling. Technical University Munich also conducted a drilling test [4] using the universal test and recorded the cutting forces and torques by the six component sensor from ATI.

Other method to measure forces and torques when drilling had also been used by past researchers. A researcher [5] used an electric current consumed by the DC motor as the sensing signal. The voltage drops that used by the DC motor indicates the forces during the drilling process. As presented in [6] there are several different drilling states and transitions for bone drilling. These states and transitions can be revealed

using sound analysis in time domain and also using spectrogram.

The values of forces and torques are important as an early detection of interfaces between layers bone tissues when drilling. This is because the different of density that exists between the layers of bone. Bone actually consists of two main parts that is cortical and trabecular. These two types are different in structure and density [7]. Cortical bone is a dense compact form of bone that lies on the outside surface of most bones like a protective shell. The trabecular bone is less dense than cortical bone because of the porous structure of the trabeculae [8].

II. SYSTEM OF ROBOT

A. Hardware of the robot

In this research experiment, Thermo Electron CRS CataLyst-5 robot was used. The most basic components of the Thermo Electron CRS CataLyst-5 robot as in Fig. 1 system consist of a CRS CataLyst-5 robot arm, C500C controller and a six degree of freedom force torque sensor that is mounting at the end effector of the CRS robot. The arm is provided with five degrees of freedom articulated joints.

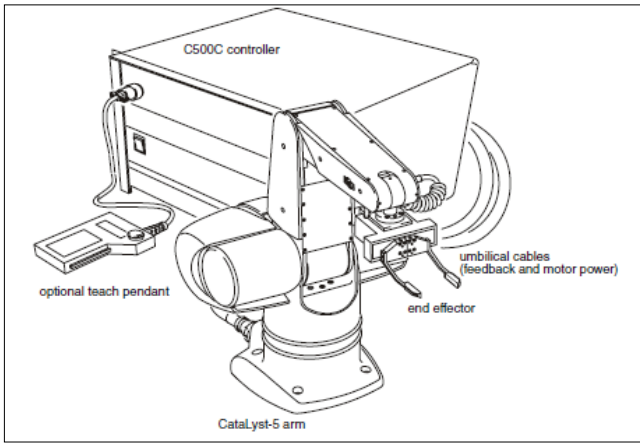

Fig. 1 Basics component of CRS

A mounting plate at its base secures the arm to a fixed platform or track. It can easily mount a variety of end effectors such as grippers or dispensers on the tool flange. It has incremental encoder for each joint to provide continuous information on motor position. CRS CatalLyst-5 arm is mounted on a track in order to move the entire arm along an additional linear axis

The C500C controller provides safety circuits, power, and motion control for the arm. It drives the motors in each joint, keeps track of motor position through feedback from the encoders, computes trajectories, and stores robot applications in memory. It also detects potentially damaging conditions such as robot runaway, severe collisions, loss of positional feedback, and errors in communication. If one of these conditions is detected, the controller immediately triggers an emergency stop or shutdown.

The force sensor mounts directly on the tool flange of the arm and has a flange for attaching end effectors. When an attached end-effectors comes into contact with an object, pressure-sensitive devices inside the force sensor measure the applied forces and torques, and transfer this information to the controller. The force sensor controller digitizes the signal and transforms it into the forces and torques which are sent to the controller.

B. Closed and open architecture system

The CRS robot capable to operate in two different modes that are in closed architecture and open architecture controller. In closed architecture mode the system is supplied with the C500C controller which has all the capabilities of an industrial robot as well as the RAPL3 programming language to teach the robot to perform specific tasks. The C500C controller contains 6 PID feedback controllers operating about each motor and its structure cannot be modified. For the open architecture mode the controller designed sends currents directly to the motors. The user is responsible for implementing a stable feedback system. The designed open architecture controller can be switched back and forth to the closed-architecture CRS controller seamlessly.

The closed-architecture system is represented by the bottom two shaded boxes in Fig. 2 when the CRS robot arm, linear track, and servo gripper are controlled via the C500C controller. As illustrated by the red-dashed lines in Fig. 2, the C500C obtains the motor position measurements from the incremental encoders and obtains the servo gripper position

from its potentiometer sensor. Note that the potentiometer voltage signal is processed by the onboard analogue-to-digital converter.

The five motors in the robot arm, the linear track motor, and the servo gripper motor, are all driven by the power amplifiers in the C500C controller. When the user commands a certain joint position with either the Teach Pendant or the RobComm3 software, the embedded PID feedback loop in the C500C controller calculates an appropriate current to drive the joint to that user-commanded position. Finally, note that because the C500C unit has one analogue input the force-torque sensor cannot be used simultaneously with the servo gripper

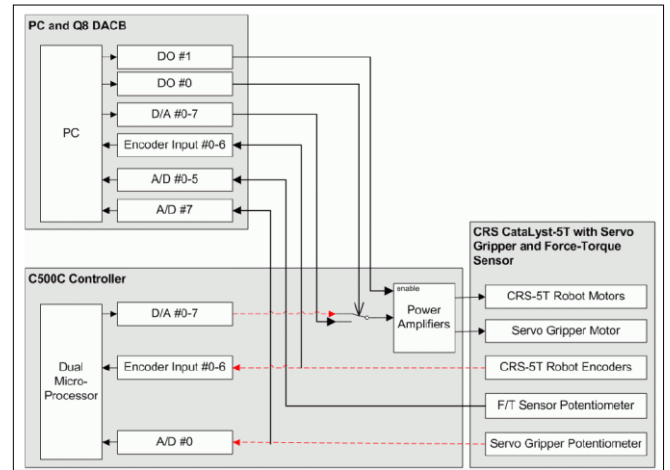

Fig. 2 Closed and open architecture system

In open-architecture mode, the encoder and potentiometer sensors and the actuators in the system are connected to the Quanser Q8 data-acquisition board, as shown in Fig. 2 by solid black lines. Instead of using the built-in controllers in the C500C system, the controller algorithm is designed with Simulink and implemented using WinCon. WinCon generates real-time code from the Simulink model and targets it on the processor of the PC. The C500C power amplifiers as well as the runaway condition and collision detection safety features offered by the C500C unit are still used.

C. Force-Torque sensor simulink model

In the force-torque sensor simulink model as shows in the Fig. 3 are build up with several subsystems that consist of CRS Inverse Kinematics, CRS Position Controller, Force-Torque sensor and Force-Torque Sensor Transformation that is for calibrate force and torque. Besides that it also has two other subsystem that is CRS takeover and Gripper Position Control. The CRS takeover is use to switch between open-architecture and closed-architecture mode. For Gripper Position Control it is use to control the position of the CRS robot servo gripper.

The subsystem for the CRS Inverse Kinematics and CRS Position Controller together with the Relative World Command are use to control the position of the end-effectors using world-based coordinates. The relative world commands are changed through the Slider Gain blocks that consist of X, Y and Z position of the end-effectors as well as its pitch and roll. The CRS Inverse Kinematics is to calculate the joint angles needed to attain the commanded world position. For CRS position Controller is used to control the position of the CRS robot joints and the position of the robot on the linear

track. Thus, from the Scope subsystem has the collection of scopes that enables to view the commanded and measured motor, joint, track and world coordinate positions.

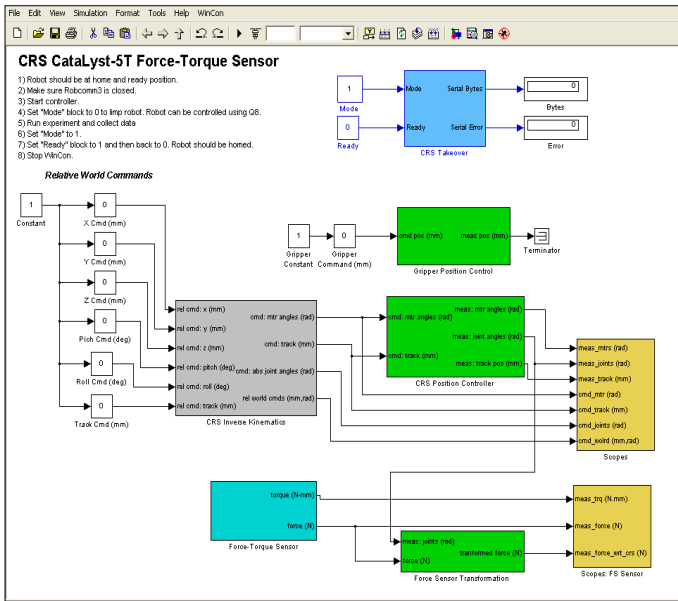

Fig. 3 Simulink model

The subsystem for the Force-Torque sensor is as depicted in Fig. 4. The Quanser Q8 ADC block that label Analog Input reads six voltages from the Force-Torque sensor Potentiometer. The resulting signals are then passed through the Force-Torque calibration gain block to compute the X, Y, and Z forces and torques generated by the sensor that are relative to the sensor body frame.

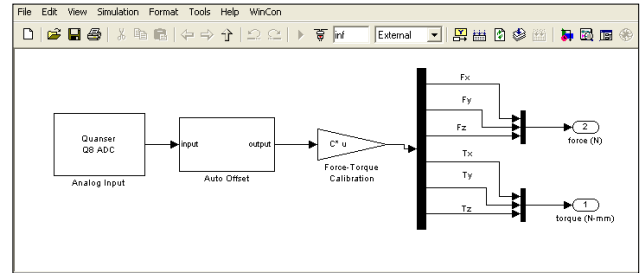

Fig. 4 Force-Torque Sensor subsystem

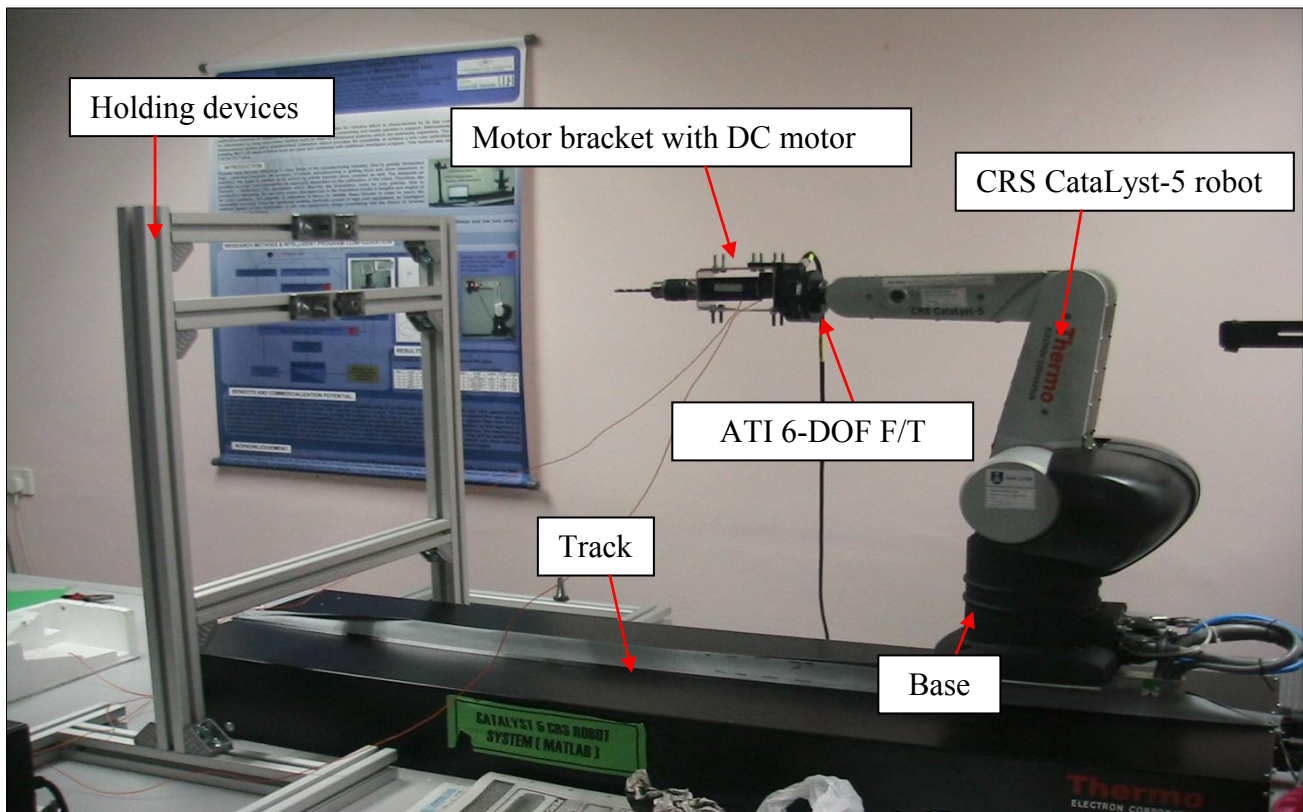

Fig. 5 Real layout drilling operation

D. Experimental of bone drilling

The real layout of the experimental of bone drilling is shown in Fig. 5. The set up of the layout are consist of CRS CataLyst-5 robot, Maxon DC motor (model RE 206508), Assembly of motor bracket, drill chuck, coupling and high speed steel drill bit (diameter 6),ATI six degree freedom Force Torque sensor and holding device. There are two materials for drilling operation that will be used in this project. The materials are the polystyrene and animal bone. The polystyrene is only used as the sample material for the drilling operation to test the condition of the CRS CataLyst-5 robot when drilling before proceed with the animal bone. The animal bone that used in this project is the cow bone as shown in Fig. 6 (tibia) to represent the non-homogenous material. The Table I below shows the properties of the cow bone.

TABLE I PROPERTIES OF COW BONE [11], [12]

Structural type	Apparent Density (g/cm ³)	Young's Modulus (Mpa)	Strength (Mpa)
Cortical	N/A	21.0±1.9	230±18
Trabecular	0.41±0.16	648±430	N/A



Fig. 6 Drilled location of cow bone (tibia)

The drilling test was performed using the Maxon DC motor that attached to the CRS CataLyst-5 robot end-effectors using the motor bracket. The drill bit is attached to the drill chuck that connected to the DC motor using the coupling. The speed of the motor is controlled based on the programmed in the Motion Perfect. The feed rate of the drilling process is controlled by the velocity and the acceleration of the CRS robot movement in the track.

There are several steps that involve in the drilling operation. The first step is to place the drilling sample on the holding device. The drilling sample is consists of polystyrene and the cow bone. Then the robot is system is switch to the open architecture mode and run under the system. Next step is to setting up the position of the CRS robot. The position of the CRS robot joints and as well the position of the robot on the track is controlled through the

Force Torque Simulink model. The step continues by setting up the motor speed or the cutting speed and the feed rate of the drilling operation. The drill was rated constantly for both polystyrene and the bone at 5000 rpm and different values of feed rate are used for the polystyrene and the cow bone. Table II shows the motor speed and the feed rate that consist of velocity and the acceleration of the CRS CataLyst-5 robot.

TABLE II VELOCITY AND ACCELERATION OF CRS CATALYST-5 ROBOT

Material		Velocity (mm/s)	Acceleration (mm/s ²)
Polystyrene	1.	10	0.1
	2.	10	1
	3.	10	10
	4.	10	20
Bone (Cow)	1.	10	1
	2.	0.01	0.07
	3.	0.01	0.05
	4.	0.01	0.03
	5.	0.01	0.01

Before proceeding with the drilling process on the drilling material, the motor is rotate freely first. This is to observe the vibration forces and torques that the motor produced. The example values of forces and torques that calibrated using the force-torque sensor are as in Fig 7. However, as for the cow bone an initial guide has to be perform first before continued when the drilling process. This is to avoid the drill bit from slip when drill the bone, since the surface on the bone is not smooth compared to the polystyrene surface.

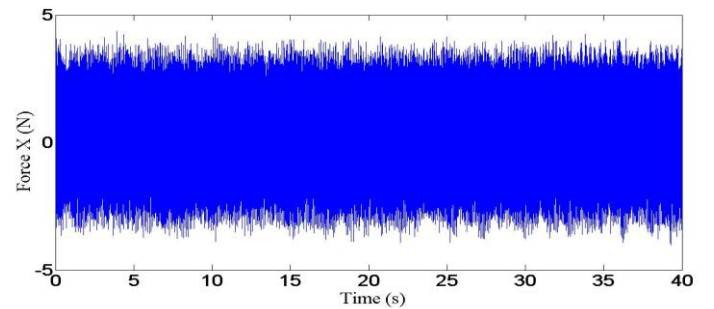

(a)

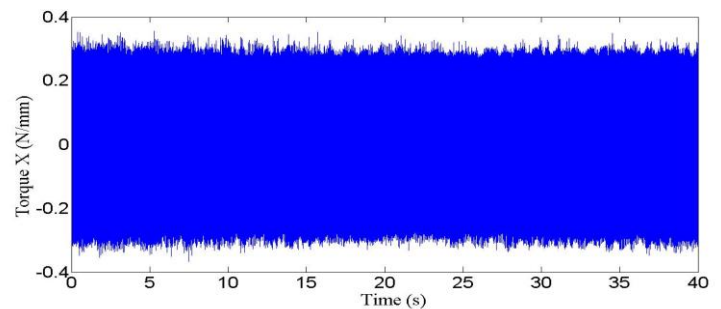

(b)

Fig. 7 (a) Force in x-direction and (b) Torque in x-direction

Different range of buffer time are set in each scope, this is because drilling process of cow bone take longer time period compared to the polystyrene. The buffer time is set between 60 s to 340 s. The data of forces and torques that obtained are saved in the Matlab M-file. Then save data can be run in Matlab to determine the forces and torques during the drilling operation.

E. Experimental results and discussion

The results of calibrated data of forces and torques that obtain during the drilling operation are shown in this section. There are two results of forces and torques that obtains. That is from the drilling operation of polystyrene and the cow bone. Both forces and torques result are compared to determine the fluctuation of forces and torques. The effects of different feed rate also been analyzed.

There are four set of results of forces and torques for drilling polystyrene. The example experimental result on polystyrene is shown in Fig. 8. The parameters for the feed rate of that use are velocity 10 mm/s and acceleration 10 mm/s². From the Fig. 8 it shows that from the time interval 0 to 33 second it indicates the states before the drilling process where it shows the values of vibration forces and torque produce by the motor. Between 33 to 35 second time interval is the drilling process state, as can be observe that there is an incremental values forces and torques. Than after 35 second is the after drilling process state, which the values of forces and torques changes back to the constant value of vibration forces and torques.

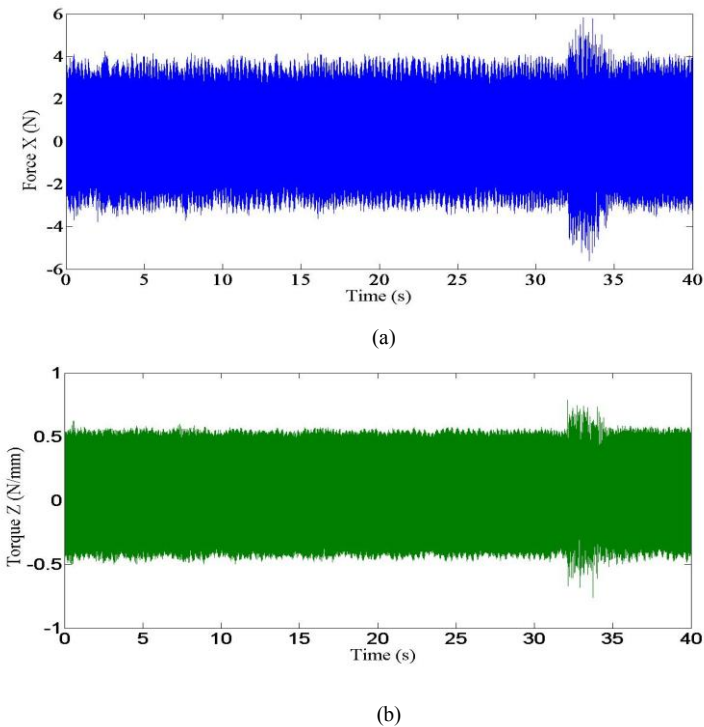

Fig. 8 (a) Force in x-direction (b) Torque in z-direction

There are five set of results of forces and torques for drilling cow bone. Fig. 8 shows the example experimental result on cow bone. The velocity and the acceleration for the parameters are set to 0.01 mm/s and 0.07 mm/s. The Fig. 9 shows that from the starting of time interval until the 240

second is the drilling process in the trabecular bone. The forces and torques fluctuate during the drilling process. After the 240 second time interval the forces and torques are increasing, except for the force in z-axis and torque in x-axis. It is decreasing during that time. The drilling state at the 240 second is the drilling process in the cortical bone. The maximum values of forces and torques that measured by other parameters for polystyrene and cow bone is shown in the Table 2.

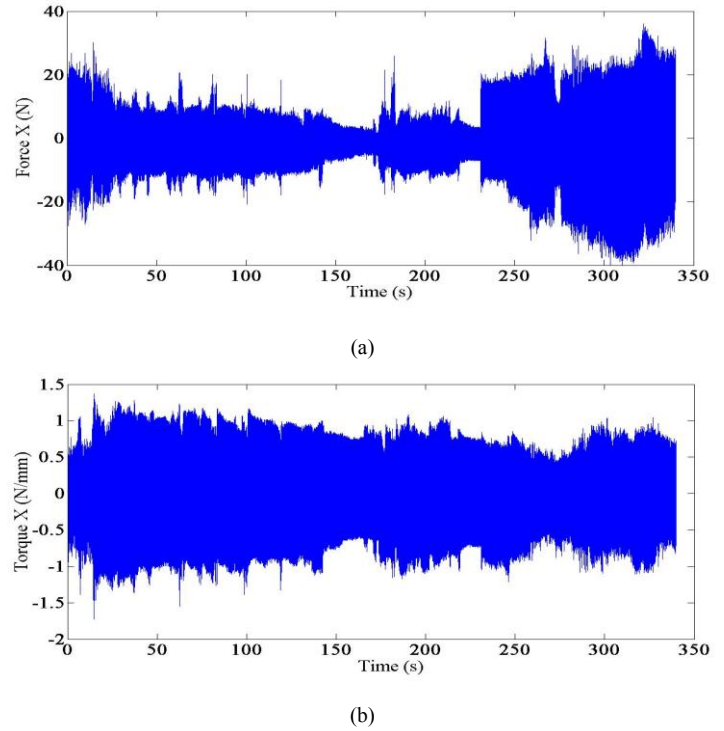

Fig. 9 (a) Force in x-direction (b) Torque in x-direction

From the results of drilling test polystyrene and the cow bone shows that the forces and torques obtained in y-axis and z-axis are higher compared in the x-axis. Theoretically, the values of force and torques in x-axis suppose should be higher since the drilling process involve the movement in the x-axis. This is because of the vibration of the motor that produced during the free drilling as shown in Fig. 7. The vibration that produced will affect the drilling process when the drill bit penetrates the hole. There will be lots of contact between the drill bit flute and the inner surface of hole due to the vibration of the motor. This will increase the forces and torques in y-axis and z-axis

The motor speed and the feed rate for drilling are important parameters that need to be considered. In this project the motor speed or the cutting speed is fixed to 5000 rpm and the feed rate is variable for different drilling test. The Table III below shows the results of maximum forces and torques either in positive or negative value with different feed rate for polystyrene and cow bone. The positive and negative values only indicate the direction of forces and torques.

From the result, it shows that the forces and torques are increase as the feed rate increase from both drilling test. This result is confirmed by the drilling theory presented in [9] that torque, thrust force and power are proportional to the feed. However there still has some decreasing of forces and toques

in drilling polystyrene. This is because polystyrene is softer compared to bone. The CRS robot managed to penetrate the polystyrene without drilling process. Therefore as the feed rate increase, it required less forces and torques to drill and penetrate the polystyrene. As for the torque value in x-axis for cow bone drilling is decrease because as a state in [10] the torque was proportional to the rotational speed.

The result of drilling test for the cow bone shows the fluctuating forces and torques. This is because the bone consists of two principle types of bone that is the cortical and trabecular bone. These bones are varied in structure and density and also depending on location making bone an anisotropic, heterogeneous material [8]. The different of the density of the cortical which is denser than trabecular cause the values of the force and torque fluctuating when drilling through the different layer on the bone.

TABLE III RESULT OF MAXIMUM FORCES AND TORQUES DRILLING COW BONE

Feed rate v (mm/s) a(mm/s ²)	F _x (N)	F _y (N)	F _z (N)	T _x (N/mm)	T _y (N/mm)	T _z (N/mm)
v = 0.01 a = 0.01	8.40	30	13.0	0.61	0.20	1.00
v = 0.01 a = 0.03	22.0	60.0	18.0	1.70	0.70	1.50
v = 0.01 a = 0.05	25.0	60.0	28.0	2.00	0.80	2.00
v = 0.01 a = 0.07	35.0	90.0	30.0	1.40	0.80	2.50

F. Conclusion and future work

Existing research only considered the values of forces and torques in single direction. For this paper the values of tri-axial force and torques are measured during the operation of drilling bone. This been proved by an experimental study that been done by drilling out the tibia of the cow bone. The drilling operation was conducted using the CRS CataLyst-5 robot that controlled by the force torque controller. The forces and torques are measured using the ATI six degree of freedom Force Torque sensor. Different values of feed rate of the CRS CataLyst-5 robot are used during the experiment.

The values of the tri-axial forces and torques are important because it can help to produce an effective bone drilling operation that can minimizes unnecessary surgical insertion and injury to the patient. This will help a fast healing process of the patient. In future it is necessary to improve the research by measuring other parameters during the drilling operation such as the the position of the end-effectors based on the world coordinates of the robot. Besides that it is possible to use surgical drill bit to have more accurate result when drilling the bone.

NOMENCLATURE

F _x	force in x-direction	N
F _y	force in y-direction	N
F _z	force in z-direction	N
T _x	torque in x-direction	N/mm
T _y	torque in y-direction	N/mm
T _z	torque in z-direction	Nmm
v	velocity	mm/s
a	acceleration	mm/s ²

ACKNOWLEDGMENT

This work has been supported and funded by National Biotechnology Division Ministry of Science, Technology & Innovation Malaysia (Grant No.02-01-01-SF0110). I would also like to thank Muhammad Azmi bin Ayub for his advice and enthusiasm through this projek

REFERENCES

- [1] Allotta, B., Giacalone, G., and Rinaldi, L.(1997). A hand-held drilling tool for orthopedic surgery. *IEEE/ASME Transaction on Mechatronics*, vol.2, no.4, p.218-229.
- [2] Wen-Yo Lee,Ching-Long Shih. (2003). Force control and breakthrough detection of a bone drilling system. *International Conference on Robotics &Automation* (pp. 1787-1792). Taipei: IEEE.
- [3] Jongwon Lee et al (2009). Cooperative robotic assistant with drill-by-wire end-effector for spinal fusion surgery. *Industrial Robot: An International Journal* , 60–72.
- [4] S. Döbele, H. Weiss, T. Ortmaier and U. Schreiber. (2006). An examination of thecutting forces in drilling/milling procedures on model bone material as the basis for setting up a semi-active robot arm. *Journal of Biomechanics*, Vol. 39,p. s211
- [5] Yeh-Liang Hsu, S.-T. L.-W. (2001). A modular mechatronic system for automatic bone drilling. *Biomedical Engineering, Applications, Basis and and Communications*, Vol. 13, No. 4, August, 2001.
- [6] NIU, Q. (2008). Modelling And rendering for Development Of A Virtual Bone Surgery System. Ann Arbor: ProQuest LLC.
- [7] An Y.H. and Draughn R.A. (2000) Mechanical Testing of Bone and the Bone-Implant Interface. CRC Press, New York.
- [8] Carter, D.R. and Hayes, W.C. (1977) The compressive behavior of bone as a two-phase porous structure. *Journal of Bone an Joint Surgery* 59-A, 954-962.
- [9] M. Elhachimi, S. Torbaty, P. Joyot. (1999) Mechanical modelling of high speed drilling. 1: predicting torque and thrust. *International Journal of Machine Tools & Manufacture*. Vol. 39. 553–568.
- [10] M. Elhachimi S. Torbaty, P. Joyot. (1998). Mechanical modelling of high speed drilling. 2: predicting torque and thrust. *International Journal of Machine Tools & Manufacture* .Vol.39. 569–581.
- [11] Martin RB, Boardman DL.(1993)The effects of collagen fiber orientation, porosity, density, and mineralization on bovine cortical bone bending properties.*Journal Biomech*.26(9):1047–54.
- [12] Rho JY, et al.(1997).The characterization of broadband ultrasound attenuation and fractal analysis by biomechanical properties. *Bone* 20(5):497–504.