

# Open Data for Evidence-based Decision-making: Data-driven Government Resulting in Uncertainty and Polarization

Ahmad Luthfi<sup>#\*</sup>, Marijn Janssen<sup>#</sup>

<sup>#</sup>*Faculty of Technology, Policy and Management, Delft University of Technology, Jaffalaan 5, 2628 BX, Delft, the Netherlands  
E-mail: a.luthfi@tudelft.nl; m.f.w.h.a.janssen@tudelft.nl*

<sup>\*</sup>*Universitas Islam Indonesia, Jalan Kaliurang KM 14.5, Yogyakarta, 55584, Indonesia  
E-mail: ahmad.luthfi@uii.ac.id*

---

**Abstract**—Over the last decade, more and more data are collected and opened. Governments actively stimulate the opening of data to increase citizen engagement to support policy-making processes. Evidence-based policy-making is the situation whereby decisions made are based on factual data. The common expectation is that releasing data will result in evidence-based decision-making and more trust in government decisions. This study aims to provide insight into how evidence-based policy based on open data can result into uncertainty and even polarize the policy-making process. We analyze a case study in which traffic and road utilization datasets are used and model the decision-making process using the Business Process Model and Notation (BPMN). The BPMN model shows how the government and business organizations can use the data and give different interpretations. Data-driven decision-making might potentially create uncertainty, polarization, and less trust in decisions as stakeholders can give different meanings to the data and arrive at different outcomes. In contrast to the common belief, we found that the more data released, the more discussions happened about what is desired according to the data. The various directions derived from the data can even polarize decision-making. In other words, the more data opened, the more people can construct their perception of reality. For further research, we recommend understanding the types and role of data to create an evidence-based approach.

**Keywords**— open data; evidence-based; decision-making; data-driven; trust; uncertainty; polarization.

---

## I. INTRODUCTION

More and more data are collected and massively opened by governments. Business enablers, government institutions, non-government organizations, and researcher communities can all receive benefits from the disclosing of data movement [1]. The releasing of more data to the public can make a significant contribution to good governance, improve public trust, and create innovations [2], [3]. However, reality might be more cumbersome [4], [5].

Many works of literature on Open Government Data (OGD) demonstrates that the disclosure of the OGD will enhance transparency and accountability of public administrations, realize the better governance, and generate confidence in the government's decisions [6] - [8]. Besides, some potential data users like researchers, businesses, or even non-public organizations can participate in evidence-based policy-making in the decision-making process [9].

At this moment, the evidence-based policy discussion has become popular in the area of the policy-makings [10], [11]. This approach is founded in the use of data collected by the government, companies, and the public to information

policy-making [12]. Hence, it advocates rational decision-making based on a rigorous and structured approach and migrates from the traditional belief of knowledge to frame a better understanding [12], [13]. Evidence-based policy is a domain of public administration referring to a situation whereby decision made by the governments are informed by objective evidence [12], [14]. In the case of open data initiatives, the evidence-based policy refers to a knowledge-based approach based on impartial fact to apprise the decision-making process. In summary, evidence approaches advocate that policy decisions should be better informed by available actual evidence and accurate scientific analysis [15].

Evidence-based policy-making is often expected to result in a single, best solutions [15], [16]. Two main advantages are using evidence-based decision-making in open data initiatives. First, it can reduce uncertainty situation about which direction to follow, as the decision to release the data is based on objective evidence on which all parties are likely to agree on [8], [17]. Second, evidence policy-making has to base on reliable facts, and this can result in new insights on the policy issues to the public [15]. These benefit factors, furthermore, can improve the inclusiveness and

constructiveness of different point of views between actors while using the open data portal [3]. Often it is expected that evidence-based policy-making will result in a single perspective on the problem that will be accepted by all parties, as all evidence will depict in the same directions. This situation should result in a consensus among stakeholders and trust in that the right decision is taken.

The objective of this research is to analyze how evidence-based decision-making can contribute to the uncertainty situation and polarization of the decision-making process. To present how the evidence-based policy-making can in use open data, a case study of traffic and road datasets is investigated. The Business Process Management and Notation (BPMN) is used to model and understand the situation and identify the important role of evidence-based knowledge for both government and business enabler to generate their data model policy.

In contrast to these expectations in the literature, we found that more open data released can result in more discussions about what is desired according to the data and can even polarize decision-making. Open data can be used to suggest different policies. The more data opened, the more people can construct their perception of reality consequent of opening large data.

This paper is structured into seven sections. In Section 1, the rationales of the study are described. Section 2 comprises the data-driven movement. In Section 3, the literature in evidence-based transition is explored. In Section 4, the conceptual model of opening a data cycle is described. The four quadrants of data-driven are provided in Section 5. In Section 6, a case study is presented showing how open can be used for evidence-based policy and can influence the uncertainty decisions in the case of opening data is illustrated. Finally, the conclusion and further research opportunities are discussed in Section 7.

## II. MATERIALS AND METHOD

In this study, we investigate a case study of the traffic and road utility dataset. The business process for opening data policy is developed using evidence-based decision-making approach and modeled in Business Process Management Notation (BMPN). Business processes show the subsequent steps taken by different organizations to make use of open data.

### A. Problem Formulation

As the community grows and develops with a variety of complex societal problems, the government faces some trials and opportunities. To tackle these problems data is collected to inform decision-making, resulting in a *data-driven government*. However, potential challenges arise in the form of providing credible data and delivering education to the community [18]. Various opportunities are the government can use data strategies that enable it to add real-time insight and analysis, and the inclusion higher of the data can stimulate the greater trust of the public [4].

Literature suggests that data-based insights can help communities and business organizations to determine the direction of their business. In principle, a data-driven strategy can open opportunities for improving citizen participation to become engaged in policy-making. In the

domain of the government, digital transformation is intended on how the government can provide new services and help changes the business model using the available dataset [19]. Besides, using the data-based policy making can improve the creation of trust from the public to the government's decision-making [16].

When data is decided to be released and given full access to the public, many potential merits can be obtained like opening new knowledge, generating great ideas or other possible value propositions [3], [20]. Various types of technological instruments can be used to convert raw data into information and knowledge. In results, it may increase product innovation, analyzing consumer behavior, or assisting in better decision-making processes. Some prospect innovations and added values from the extension of opening data might have significant impacts [21].

Nevertheless, to provide open data for use by the public and to facilitate the evidence-based policy-making is challenging. There are many obstacles to carry out changes in the digital transparency outlook, including [22], [23]: (1) the gap between the actual data provided by government agencies and the need for data that might not be in balance. For decision-making, other types of data might be needed; (2) data collection techniques might be ineffective and far from the public's desire due to regulatory constraints and limited resources, and (3) opinion-based evidence might still dominate so that it does not have a strong argument for decision-makers. For example, the fact is clear about climate change; however, yet some people neglect the evidence.

In this situation, the government's policy-making aims to provide reliable and capable data services for the broader community with a high level of trust. Here evidence-based decision-making should contribute to creating the public trust to the data providers. To illustrate, we use the BPMN to model and make a clear understanding of how important evidence-based approach can influence the decision-making process for both government institution and business organization.

### B. Evidence-based Decision-making

A data-driven government is expected to improve the decision-making quality. Decisions can be categorized in different ways, such as opinion versus evidence-based decision-making [12], [24]. First, it is called opinion-based decisions where most of the policies taken are based on personal beliefs or organizational expertise. This belief comes from norms and ideas developed in the past that was used to confirm the faith itself. The decision-making process in organizations often taken into account the logical thinking and trust from the most influential people in the organization system [15]. Therefore, the results of this type of decision can have an impact on the bias and difficult analogy to be used as a reference for the subsequent decisions.

In contrast, evidence-based decisions are decisions taken from the objective knowledge institutions. In this approach, evidence-based decisions take the individual or group beliefs and test the opposite of its belief. This decision model has a more robust and objective foundation because scientific evidence can disprove their original opinions or ideas. A transition from opinion-based policies into evidence-based policies is expected [12]. Evidence-based policy, although it

has an impact on the need for a longer time, the use of scientific and rational thinking will produce better quality decisions. The rigorous process of gathering knowledge and critically assessment process of each sub-policy makes this decision model can be accounted.

The emergence of the idea of issuing evidence-based policies has existed for a long time [10]. In principle, evidence-based is combining several elements, namely scientific knowledge, pragmatic sources of expertise, and value-based [25]. The evidence-based policy presents a petrifying approach for both individuals and organizations. The objective is to make the appropriate decisions on the strategic programs they develop by placing the best available evidence at the most critical point of the decision-making process [26]. The discourse of evidence-based policies has become very popular not only in the scientific community but also in government institutions and business organizations [15]. The unique characteristic inherent in evidence-based policy-making is prioritizing evidence meta-analysis and randomized trials compared to other evidence-based methods [27].

Some of the stable characteristics possessed by evidence-based policy, among others, are [10], [24]: First, prioritizing the principle that the decision-making process must be well-formulated. The formulation of this policy serves to make each stage of the process to remain consistent in looking at the scientific evidence rather than just oriented towards the result or goal. Second, decisions taken by consideration of objective evidence produce more rational, rigorous, and structured arrangements. Third, scientific evidence is not only used to build policy but also has a knowledge-based for its users.

The evidence-based policy initiative has two critical roles, namely [14] to reuse what we have the knowledge to build knowledge-based determinations that exist and to inform of the interests of the decision in the future. For this reason, the priority data are needed from the results of the scientific report, empirical studies, and literature. The evidence-based policies can shape the decision-making process to produce a good and systematic based on the knowledge [11]. Governments and other private organizations can learn to what extent their program has an impact on efficiency and business objectives [10], [13]. Besides, if the knowledge-based possessed by proof, the application or model designed does not have a profit impact on the organization. It means that the policy can be stopped or postponed [15]. It can be beneficial for organizations to remain consistent in adhering to a robust scientific-based perspective.

Theoretically, the evidence-based policy is separated into two main categories, namely: mechanistic evidence and statistical evidence [27]. Mechanistic evidence is evidence that connects facts to the results of analysis by producing a definite hierarchy of evidence. The results of case studies, experimental reports in the laboratory, consortium of scientists, and the results of the expert team consensus can be claimed as mechanistic evidence sources. Statistical evidence, on the other hand, is defined as factual data produced in using observational and experimental research approach.

There are three fundamental differences between mechanistic evidence and statistical evidence. First,

statistical evidence is the quantitative domain, while the mechanistic evidence is defined as a qualitative part. Second, statistical evidence manages the population data, while mechanistic evidence only covers the area of one unit or individual using case studies. Third, statistical evidence analyses the macro data extensively, and mechanistic only deals with micro-problems. The following aspects characterize evidence-based decision-making [15], [28]:

1) *Objective data*: Use of actual data to prove whether a proposition is true or valid. Sensors and other ways used to collect the data, so the data cannot be disputed.

2) *Collecting rigorous evidence*: Evidence that obtained from a thorough analysis process using randomizes technique to support the arguments of the policy-makers.

3) *Construct evidence based on analytical techniques*: Use of statistics and analytics and activities aimed at identifying and evaluating programs and policies in an organization to achieve specific objectives using a variety of rigorous scientific methods.

4) *Using evidence methods*: The method of collecting, analyzing, and using data should be rigorous. Implement the theory of evidence-based policy-making by adhering to the principles of a methodology that is strong and able to predict some potential influence post-decision-made.

Several other important factors to make a smooth transition from opinion-based policies to evidence-based policies, as follows [24], [29]: First, the impartiality of the evaluator unit to ensure that the evidence presented has authenticated and is valid. Second, the leadership fully supports the process of evaluating the evidence and the results of policies that are difficult for any party to intervene. Third, during the evaluation period, the team must uphold the protection of privacy against personal identities or company secrets. Fourth, the rules for sharing administrative and quantitative data, including company balance sheet statistical reports must be well designed.

Furthermore, in an organization, decision-makers are often facing the variations of decisions made simultaneously. Not surprisingly, the framework is structured in a very minimalist way to be used as a shortcut to decision-making without considering the knowledge base as evidence. Decision-Makers are not only responsible for their decisions, but also must consider other important aspects. The potential for low public trust and increasing uncertainty due to a lack of understanding of the policy are severe impacts that must be considered by the organization [17].

In summary, government institutions and other non-governmental organizations often adapt evidence-based decision-making as an approach to minimize the uncertainty and to degrade the potential polarization of the decision-making process. The four characteristics of evidence-based decision-making can help the government to consider the decisions based on the objective data, rigorous sources of data, the use of appropriate analytical techniques, and implement the methodology to predict the post-decisions-made.

### C. Open Government Data in Policy-making

In this paper, we use the evidence-based policy-making cycle to understand the decisions made based on opening

data. A conceptual model of the policy cycle in open data domain is shown in Figure 1. The policy process in opening data is never as linear as implied in the model. Nevertheless, looking at the policy process regarding these stages and cycle can help us to understand how the policy-making works.

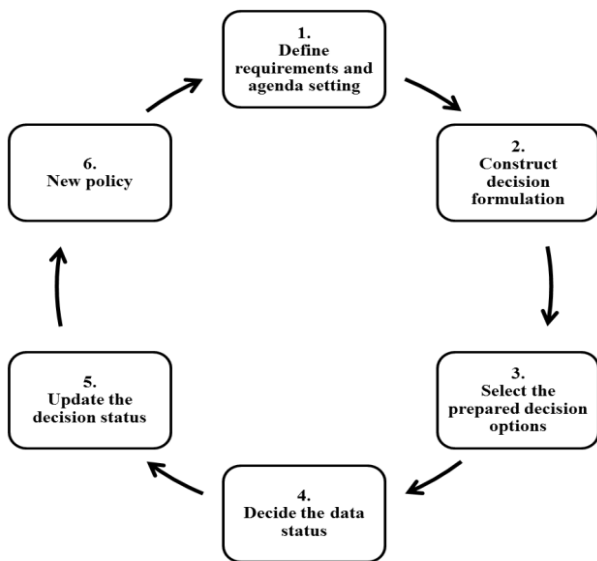

Fig. 1 The policy cycle in opening data [7], [12]

Figure 1 presents the iteration process on how the data providers like governments, business organizations, and other non-governmental institutions use the policy cycle to maintain and update the opening data to the public. There are six main steps in cycling the policy to open the dataset as can be seen in detail [7], [12], as follows:

1) *Define requirements and agenda setting*: Determine the main elements of data opening policy, such as preparing datasets, analysis instruments, and evaluation methods, up to the classification of users involved in the system. Establish a routine scheduling system to ensure that the policy-making process is structured and has a priority scale. Therefore, a key factor in this stage is how organizations can communicate credible evidence for the policy analysis requirements.

2) *Construct decision formulation*: The formulation of policy strategies is designed to build alternative decisions on opening data. This alternative decision is a reference related to the collection of evidence and recommendations, whether the dataset needs to be opened, limited access, or decided to close.

3) *Select from preferred decision option*: Based on strong evidence and references, the organization can then choose and determine the most appropriate alternative at the moment. Valid and systematic conditions of the knowledge base in the construction phase in step 2 significantly influence decisions in this step.

4) *Decide the data status*: At this stage, the status of the dataset is executed. Decision-makers want the status of the published data to be opened, given limited access to risk factors for example, or if it is decided to remain closed as part of the policy process that best favors the needs of data users.

5) *Update the decision status*: Renewal of the status of the policy in opening data is possible when the dataset whose status has been decided in the previous stage needs to be reviewed. At this stage, the related unit needs to reassess the dataset by updating the knowledge base as the latest scientific evidence.

6) *New policy*: Refer to the results of updating the dataset in stage 5. Thus the organization will have the latest decision status.

The policy cycle shown in Figure 1 might require several interactions to arrive at the best alternatives. The focus of this research is the importance of organizations to use evidence-based decision-making approach. Decision-makers will efficiently use the facts and knowledge bases when a dataset needs to be updated. In sub-section 6, we illustrate the iteration stages of policy-making in a case study based on an evidence-based policy model.

There are numerous works of literature discussed the characteristics of evidence-based policy. The four attributes of the evidence-based policy of relevance for opening data [25], [30], namely:

- Analyze and test scientific evidence of a policy based on the knowledge base to determine the external impact of the decision to open data if the policy is successfully implemented.
- Assess whether the proposed policy has a horizontal influence at the organizational level and related units if a dataset is decided to be open to the public.
- Test whether uncertainty can be managed if the policy produces a decision to open data.
- Balancing the potential for the polarization of a policy against data released by the organization to the public.

TABLE I  
THE CHALLENGES TO IMPLEMENTING THE EVIDENCE-BASED POLICY IN OPENING DATA. [17], [30], [31]

	Challenge	Description
1	<b>Evidence-constructing takes time</b>	To get detailed research results, the process of collecting, analyzing, and testing data requires a complicated allocation of time. Data is not always easily described and available in an organizational unit. Sometimes the analyst team needs to conduct a survey or even a particular case study that takes a long time to get feedback from the data provider.
2	<b>Good evidence requires skilled manpower</b>	To have objective evidence requires capable skills and expertise from officers in an organization. Solving quantitative or qualitative research problems, for example, requires people who are skilled and academically qualified.
3	<b>Political influences</b>	The norms, culture, and political pressure on certain parties can hinder or limit the implementation of evidence-based policies. For organizations that are not professional, political intervention in policy-making is a significant barrier because they do not have a strong commitment as a good organization.
6	<b>Misunderstanding can lead to uncertainty</b>	Misinterpretation of the data due to the weak ability to analyze the situation, the entities involved, and the complete ecosystem of the organization cause conditions of uncertainty about the status of data opening.

It is complicated to bring up all the ideal characteristics in policy-making using the evidence-based policy approach. However, the four essential attributes of evidence-based policy must be attached to the stages of policy-making in opening the data. Some challenges that might be faced when designing policies in evidence-based organizations can be seen in Table 1.

### III. RESULT AND DISCUSSION

To represent the better understanding of how the transition process from opinion-based policy to evidence-based policy, including the influence factors, we design the data-driven evidence-based policy environment in the case of opening data as is shown in Figure 2.

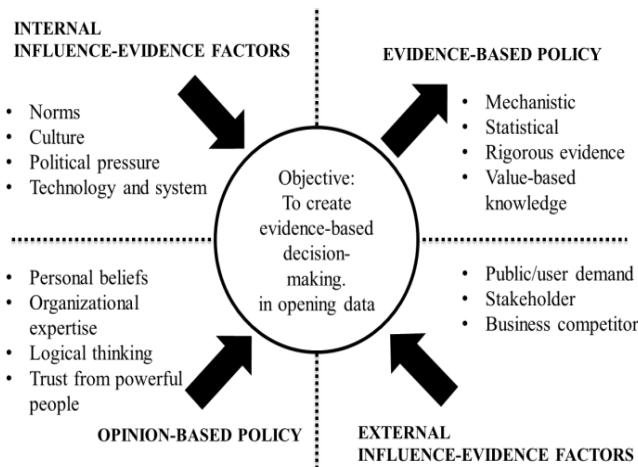

Fig. 2 Data-driven evidence-based policy quadrants [12], [27], [30]

The data-driven environment in Figure 2 is divided into four quadrants. Before beginning to describe in depth every single of important quadrants, we require to define the objective of this transition. The goal of the shift away from opinion-based to evidence-based policy-making is to manage the uncertainty and polarization situations of decision-making in opening data. Next, we explain more detail the four quadrants of this model, as follows:

#### A. Opinion-Based Policy Quadrant.

Opinion-based decision-making is a strategy to defend the status quo of the organizational system using individual or institutional beliefs. The organization is tending to use their personal feeling to establish their policy. Supporting factors like logical and individual rational perspective and fully trust from the most potent people might influence the decision-makers.

#### B. Evidence-Based Policy Quadrant.

Evidence-based decision-making is a reform model to enhance the quality of the decision in organizations by using mechanistic, statistical, and other rigorous evidence. The dependence elements in this approach can be influenced by objective knowledge, scientific analysis, literature, value-based knowledge, and accurate evidence. These kinds of elements highly require the availability of both technology system and human resources to make decision qualified. Also, the confidence and strong commitment from the leader are also importantly involved. In the final stage of the process, however, the decision is often depending on the decision-makers policy.

#### C. Internal Influence-Evidence Factors Quadrant.

There are some potential factors could be influenced and shaped the decision-making process from the internal organizations. Entities like existing norms, culture, and behavior of the organization's management, strict regulation, the reluctance of the leader to change the guideline, and a limited budget to develop new technology and system might degrade the evidence-based policy movement.

#### D. External Influence-Evidence Factors Quadrant.

The external influence-evidence factors can be represented by two important components, namely: the high demand of the public and stakeholders to access and reuse the dataset considering the strong objective evidence, and the awareness of the organizations through the competitor's movement can drive the leader to reform the existing policy-making process.

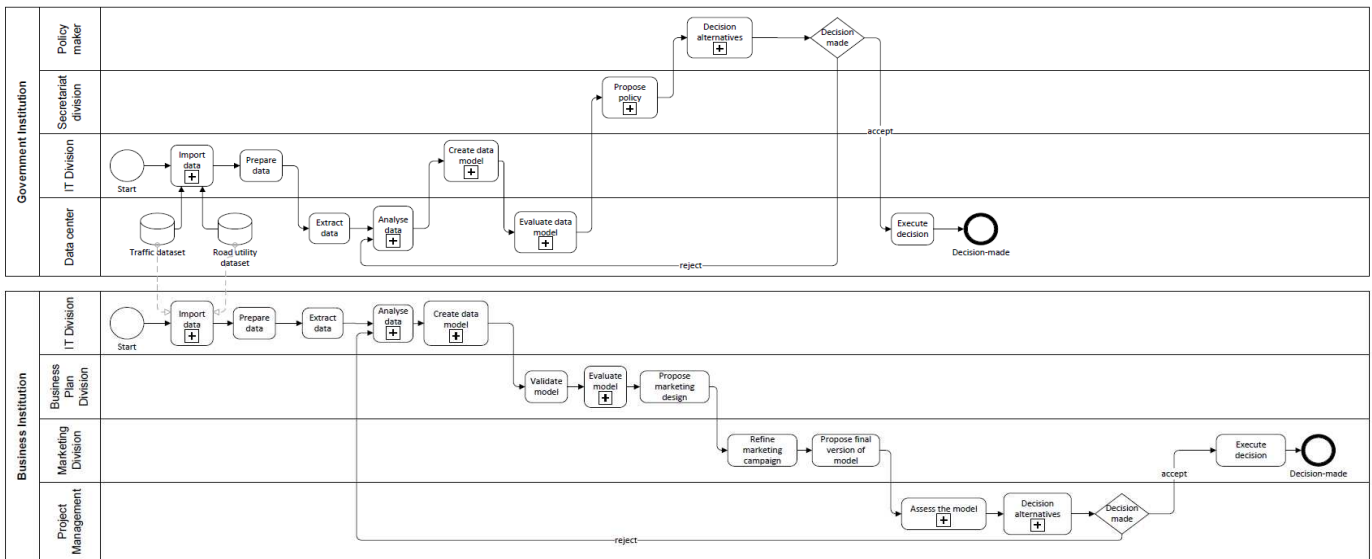

Fig. 3 The business process in opening data using evidence-based decision-making approach

The policy cycle shows how open data can be used in policy-making processes. Open data should contribute to the evidence-based decision which will be investigated in the case study presented in this section. The business process for opening data policy using evidence-based decision-making approach and visualize will be modeled using Business Process Management Notation (BMPN). A business processes show the subsequent steps taken by different organizations to make use of open data. For the case study, we select the traffic and road utility dataset to illustrate the process as visualized in Figure 3.

In the business model process, the scenario of the case study describes in detail into four main parts:

1) *Organizational involvement*: There are two institutions involved in the case study designed in this illustration. First, the government institution which is the provider of datasets, and the second is business institutions that collectively use data sources from the government. The involvement of these institutions is that the dataset published by the government can be accessed and used by other potential users like the company, researchers, and other governmental organizations. With the available datasets, the government can analyze the historical and density of data traffic for instance. Thus, the government uses a dataset of traffic and road utilities in the interest of making decisions to improve public services. Meanwhile, the business organization has an interest in using datasets to improve new marketing innovation by analyzing road use density, vehicle volume, and pedestrian behavior, for instance.

2) *Multi-actors and job description*: Each institution has their sub-division of works that act a specific role in the decision-making process. In government institutions, four working units interact to issue a public policy. First, the data center is a unit that accommodates business-critical ICT equipment. Second, the IT division is a working unit that manages and maintenance of the systems and technology in government infrastructure. Third, secretariat division is a working unit that covers some approval issues for submitting a policy prototype for a system product. Forth, policymaker is the individual or working unit that are having the authority to provide alternative policies and deciding whether a proposed product system is accepted or rejected. In the business organization side, it is also designed to have four work divisions. First, IT division is a unit responsible in the information technology resources, including assessing datasets from the government to the enterprise business data. Second, business plan division is a unit responsible for evaluating business models generated by IT units. Third, the marketing division is a working unit that designs and selects the right business model for the company. Forth, project management division is the last node of the long process of policy-making, which has the role of providing various policies alternatives including ensuring whether the proposed model can be accepted or rejected. With the design of each work unit in the two institutions of this illustration, we hope that the level of complexity of policymaking can be better understood.

3) *The current business process in opening data*: To provide new knowledge in the process of opening data that run on both institutions, we also illustrate how each unit plays a role in producing a policy product. In government

institutions, the process starts with the IT division that imports dataset traffic and road utilities from the data center division. Then, preparing the data analysis by extracting, transforming, and loading (ETL) the dataset in the data center working unit. After the data is analyzed, the data center sends a data packet to the IT division to degenerate a new model data. At this stage, in-depth analysis is needed using the objective evidence-based approach (the specific activities are explained in part 4). After the data model is designed, the data center unit will evaluate the model before sending it to the secretariat division. The secretariat division, further, will propose several policy packages to decision makers. In the end, the policymaker who decides whether the data model can be executed or vice versa must be considered to re-evaluate the process. Unlike government institutions, in business institutions, the data model is analyzed and directly degenerated by the IT division. Hence, the evidence-based policy consideration process is in this division. Meanwhile, the validation process, model evaluation, and marketing design proposal are carried out by the business work unit plan. Turning back to the role of the marketing division, this unit selected the proposed model and finalized the version then sends it to project management. The final node in this process is that the assessment and termination of the model status carried out by project management is the power to execute the model or even the potential to re-evaluate this process.

4) *Evidence-based decision-making*: This part has a critical point to ascertain whether the product model data is factually analyzed using an evidence-based approach. The stages of evidence-based are analyzed in the create data model both by the government and business organizations. To make details of what has done at this stage, we will explain based on each division. In government institutions, the evidence-based policy analysis process using the mechanistic approach. First, the dataset is analyzed based on the results of the research with the post-action research. The objective is to explore the scientific evidence whether the datasets have potential value-based knowledge. Second, other evidence-based analysis can look at the results of network traffic analysis from a research institution that uses a qualified laboratory to ensure that the training data used is valid and credible. Meanwhile, on the side of business institutions, the process of the evidence-based policy uses a statistical approach to get more value of the selected dataset. The datasets obtained from the government uses experimental research from a scientific institution. The aim is to analyze the traffic data and road utilization based on statistical reports. For example, the statistics of the road density, budget allocation, and the trend of pedestrians' behavior using a product service. Here can predict consumer behavior at certain times and conditions when using public company products for instance.

The policy-making processes in Figure 3 show how important the role of each work units develops a policy product. A better understanding of the available data results in the use of the data for evidence-based decision-making. However, to obtain data with strong evidence source from research institutions in both mechanistic and statistical forms is certainly not easy. Therefore, cooperation in producing good quality and analytical data between data providers,

government and business organizations is implicitly necessary. Also, data should be collected and opened for use by others to ensure that the thresholds of use are lowered.

The multiple stakeholders involved in the process can arrive at other outcomes with the same data. The stakeholders might have different or even opposing interests. Whereas a stakeholder from a green political party might be interested in pollution by traffic, a stakeholder from a liberal party might be interested in economic growth by stimulating traffic. The same open data can be used to arrive at other evidence-based policy-suggestions. The pollution data might suggest that a particular area is too polluted (above the norms) and by reducing the traffic, this pollution can be decreased.

On the other hand, from an economic perspective, the open data might suggest that more traffic is needed to facilitate the trading in that area resulting in economic growth and less unemployment. The people living in the polluted area might strongly oppose any measures increasing the pollution, whereas the unemployed might want to increase the economic activity in that area resulting in polarization in society. The more data opened, the more people can construct their perception of reality, which might create more uncertainty about the direction taken and into more polarization in society.

The different outcomes can result in *uncertainty* about which decision should be taken. The open data and evidence-based analysis point towards different issues. There is no single 'best' or 'optimal' outcome, as is often assumed behind evidence-based decision-making. Directions are based on political preference and contemporary moods in society. In contrast to the common expectation, we found that the more data released can result in more discussions about what is desired according to the data. Opening more data might result in a decline in trust in decision-making, as the data does not show a consistent picture. It might create the awareness of different directions that might be first taken for granted.

The open data can result in a *polarization* in which the political party determines the stance on the problem instead of the evidence. In our illustration, both parties search for evidence that supports their view. Polarization might even result in thinking that the other party tries to misguide the public and in distrust between the parties. Although the data and evidence are factual, the outcomes result in different policies and decisions based on the normative stance. The data might result in greater polarization at the political level, but also at the societal level. Polarization can result in greater policy volatility.

#### IV. CONCLUSION

A common expectation is that the opening of data will result in a data-driven government making use of evidence-based policy-making. The idea is that these policies are hardly contested as these are based on factual data. Despite open data can result in evidence-based policies, realizing this might be more difficult. Factors like lack of organizational capacity, less of human resource expertise, views are taken on the data, and weak commitments from decision-makers are some challenges to prevent the use of evidence-based policy-making. Even if the data is used correctly, the

releasing of more data can result in more discussions about what is desired policy direction according to the data. The various directions derived from the data can result in the polarization of decision-making. In other words, the more data opened, the more people can construct their own perception of reality. Whereas evidence-based policy refers to a knowledge-based approach based on impartial evidence to inform the decision-making process, the data is often collected for a particular purpose and using different analytics outcomes can be created. This suggests that the common 'rational' view on data providing a single answer is an oversimplification of reality. The case study illustrated how an evidence-based approach can result in uncertainty about the direction to be taken and that the data can support different directions. This can result in polarization of decision-making, as both sides find their policy-direction supported by data.

For further research, we recommend conducting in-depth case studies to understand how data can be used in evidence-based policy-making. A deep understanding of the data, its possible use and for the different purposes it can be used is essential. Some data might only be interpreted singly, whereas other data might be interpreted in various ways depending on the view is taken.

#### REFERENCES

- [1] G.-H. Kim, J.-H. Chung, and S. Trimi, "Big Data Applications in the Government Sector: A Comparative Analysis among Leading Countries," *Communication of the ACM*, vol. 57, no. 3, pp. 78-85, 2014.
- [2] I. Bedini, F. Farazi, D. Leoni, J. Pane, I. Tankoyeu, and S. Leucci, "Open Government Data: Fostering Innovation," *eJournal of eDemocracy and Open Government (JeDEM)*, vol. 6, no. 1, pp. 69-79, 2014.
- [3] A. Zuiderwijk, and M. Janssen, "Open Data Policies, Their Implementation and Impact: A Framework for Comparison," *Government Information Quarterly*, vol. 31, no. 1, 2013.
- [4] F. Bannister, and R. Connolly, "The Trouble with Transparency: A Critical Review of Openness in e-Government," *Policy & Internet*, vol. 3, no. 1, pp. Article 8, 2011.
- [5] A. Luthfi, Z. Rehena, M. Janssen, and J. Cromptvoets, "A Fuzzy Multi-criteria Decision Making Approach for Analyzing the Risks and Benefits of Opening Data."
- [6] P. Arzberger, P. Schroeder, A. Beaulieu, G. Bowker, K. Casey, L. Laaksonen, D. Moorman, P. F. Uhlir, and P. Wouters, "Promoting Access to Public Research Data for Scientific, Economic, and Social Development," *Data Science Journal*, vol. 3, 2004.
- [7] A. Luthfi, and M. Janssen, "A Conceptual Model of Decision-making Support for Opening Data," in 7th International Conference, E-Democracy 2017, Athens, Greece, 2017, pp. 95-105.
- [8] A. Luthfi, M. Janssen, and J. Cromptvoets, "A Causal Explanatory Model of Bayesian-belief Networks for Analysing the Risks of Opening Data." pp. 289-297.
- [9] T. Greenhalgh, and J. Russel, "Evidence-Based Policymaking: A Critique," *Perspectives in Biology and Medicine*, vol. 52, no. 2, pp. 304-318, 2009.
- [10] V. Weerakkody, H. Lee, and P. Waller, "The Role of e-Participation and Open Data in Evidence-Based Policy Decision Making in Local Government," *Journal of Organizational Computing and Electronic Commerce*, 2015.
- [11] A. Larquemin, J. P. Mukhopadhyay, and S. Buteau, "Open Government Data and Evidence-based Socioeconomic Policy Research in India: An overview," *The Journal of Community Informatics*, 2016.
- [12] S. Sutcliffe, and J. Court, "Evidence-Based Policymaking: What is it? How does it work? What relevance for developing countries?," 2005.
- [13] W. Strydom, K. Nortje, N. Funke, and M. Steyn, "Evidence-based policymaking: A review," *South African Journal of Science*, vol. 106, no. 5/6, pp. 1-8, 2010.

- [14] H. Straßheim, and P. Kettunen, "When does evidence-based policy turn into policy-based evidence? Configurations, contexts, and mechanisms," *Evidence & Policy A Journal of Research Debate and Practice*, vol. 10, no. 2, pp. 259-277, 2014.
- [15] J. Volmink, "Evidence-informed Policy Making: Challenges and Opportunities," *British Medical Journal Global Health*, vol. 2, no. 2, 2017.
- [16] D. Özkundakcia, P. Wallaceb, H. F.E.Jonesa, S. Hunta, and H. Gilesa, "Building a reliable evidence base: Legal challenges in environmental decision-making call for a more rigorous adoption of best practices in environmental modelling," *Environmental Science & Policy*, vol. 88, pp. 52-62, 2018.
- [17] D. M. Rousseau, "Makin evidence-based organizational decisions in an uncertain world," *Organizational Dynamics*, vol. 47, pp. 135-146, 2018.
- [18] J. Stragier, P. Verdegem, and G. Verleye, "How is e-Government progressing? A Data Driven Approach to E-government Monitoring" *Journal of Universal Computer Science*, vol. 16, no. 8, pp. 1075-1088, 2010.
- [19] S. G. Grimmelikhuisen, and A. J. Meijer, "Effects of Transparency on the Perceived Trustworthiness of a Government Organization: Evidence from an Online Experiment," *Journal of Public Administration Research and Theory*, vol. 24, no. 1, pp. 137-157, 2014.
- [20] A. Yannoukakou, and I. Araka, "Access to Government Information: Right to Information and Open Government Data Synergy," *3rd International Conference on Integrated Information (IC-ININFO)*, vol. 147, pp. 332-340, 25 August 2014, 2014.
- [21] T. Jetzek, M. Avital, and N. Bjorn-Andersen, "Data-Driven Innovation through Open Government Data," *Journal of Theory Application and Electronic Commerce*, vol. 9, no. 2, 2014.
- [22] A. Puddephatt, and R. Zausmer, "Towards open and transparent government," *International Experiences and Best Practice: Global Partners and Associates*, 2011.
- [23] M. Janssen, and J. Van den Hoven, "Big and Open Linked Data (BOLD) in Government: A Challenge to transparency and privacy," *Government Information Quarterly*, vol. 32, no. 4, pp. 363-368, 2001.
- [24] K. Sundell, K. Tengvald, H. Soydan, and S. Anttila, "From Opinion-Based to Evidence-Based Social Work: The Swedish Case," *Research on Social Work Practice*, vol. 19, no. 5, 2009.
- [25] B. Head, "Evidence-based policy: principles and requirements."
- [26] T. Davies, *Open data, democracy and public sector reform: A look at open government data use from data. Gov. uk*, Oxford Internet Institute, 2010.
- [27] C. Marchionni, and S. Reijula, "What is mechanistic evidence, and why do we need it for evidence-based policy?," *Studies in History and Philosophy of Science*, 2018.
- [28] J. Milner, and M. Eldridge, *From Evidence to Outcomes: Using Evidence to Inform Pay for Success Project Design*, 2016.
- [29] W. J. Congdon, and M. Shankar, "The Role of Behavioral Economics in Evidence-Based Policymaking," *Political and Social Science*, vol. 678, no. 1, pp. 81-92, 2018.
- [30] A. Luthfi, M. Janssen, and J. Cromptvoets, "Framework for Analyzing How Governments Open Their Data: Institution, Technology, and Process Aspects Influencing Decision-Making."
- [31] G. Banks, "Challenges of evidence-based policy-making," *Contemporary government challenges*, 2009.