



UNIVERSIDADE ESTADUAL DE CAMPINAS
Instituto de Biologia

NÍDIA MARA MARCHIORI

FUNCTIONAL NITROGEN USE STRATEGIES IN HUMAN
MODIFIED ATLANTIC FOREST GRADIENT

ESTRATÉGIAS FUNCIONAIS DO USO DE NITROGÊNIO EM
UM GRADIENTE DE PERTURBAÇÃO ANTRÓPICA NA MATA
ATLÂNTICA

CAMPINAS

2018

NÍDIA MARA MARCHIORI

**FUNCTIONAL NITROGEN USE STRATEGIES IN HUMAN MODIFIED
ATLANTIC FOREST GRADIENT**

**ESTRATÉGIAS FUNCIONAIS DO USO DE NITROGÊNIO EM UM
GRADIENTE DE PERTURBAÇÃO ANTRÓPICA NA MATA
ATLÂNTICA**

*Thesis presented to the Institute of Biology of the
University of Campinas in partial fulfillment of the
requirements for the degree of Doctor in Plant
Biology*

*Tese apresentada ao Instituto de Biologia da
Universidade Estadual de Campinas como parte
dos requisitos exigidos para a obtenção do título
de Doutora em Biologia Vegetal*

ESTE ARQUIVO DIGITAL CORRESPONDE À
VERSÃO FINAL DA TESE DEFENDIDA PELA
ALUNA NÍDIA MARA MARCHIORI ORIENTADA
PELO DR. MARCOS PEREIRA MARINHO
AIDAR.

Orientador: Dr. MARCOS PEREIRA MARINHO AIDAR

**CAMPINAS
2018**

Agência(s) de fomento e nº(s) de processo(s): FAPESP, 2012/51872-5; CNPq, 142321/2015-0

ORCID: <https://orcid.org/0000-0002-3421-263X>

Ficha catalográfica
Universidade Estadual de Campinas
Biblioteca do Instituto de Biologia
Mara Janaina de Oliveira - CRB 8/6972

M332f Marchiori, Nidia Mara, 1986-
Functional nitrogen use strategies in human modified Atlantic Forest gradient
/ Nidia Mara Marchiori. – Campinas, SP : [s.n.], 2018.

Orientador: Marcos Pereira Marinho Aidar.
Tese (doutorado) – Universidade Estadual de Campinas, Instituto de
Biologia.

1. Fragmentação florestal. 2. Nitrogênio. 3. Nitrato redutase. 4. Degradação
ambiental. 5. Atributos funcionais. I. Aidar, Marcos Pereira Marinho. II.
Universidade Estadual de Campinas. Instituto de Biologia. III. Título.

Informações para Biblioteca Digital

Título em outro idioma: Estratégias funcionais do uso de nitrogênio em um gradiente de
perturbação antrópica na Mata Atlântica

Palavras-chave em inglês:

Forest fragmentation

Nitrogen

Nitrate reductases

Environmental degradation

Functional traits

Área de concentração: Biologia Vegetal

Titulação: Doutora em Biologia Vegetal

Banca examinadora:

Marcos Pereira Marinho Aidar [Orientador]

Tomas Ferreira Domingues

Halley Caixeta de Oliveira

Plínio Barbosa de Camargo

Catarina Carvalho Nievola

Data de defesa: 29-01-2018

Programa de Pós-Graduação: Biologia Vegetal

Campinas, 29 de Janeiro de 2018

COMISSÃO EXAMINADORA

Prof. Dr. Marcos Pereira Marinho Aidar

Prof. Dra. Catarina Carvalho Nievola

Profa. Dr. Halley Caixeta de Oliveira

Prof. Dr. Plínio Barbosa de Camargo

Prof. Dr. Tomas Ferreira Domingues

Os membros da Comissão Examinadora acima assinaram a Ata de defesa, que se encontra no processo de vida acadêmica do aluno.

AGRADECIMENTOS

Com essa súmula eu finalmente termino minha tese de Doutorado. De fato, não é tarefa simples, mas é mesmo muito gratificante finalizar mais essa etapa de formação acadêmica. Impossível teria sido executar essa tarefa sem o grande apoio da equipe de campo/laboratório, sem minha família, amigos, orientador e agências de fomento (CNPq e FAPESP). Momentos de alegrias, risadas, tristezas e frustrações são vividos com maior ou menor intensidade quando se tem grandes pessoas ao lado, portanto, muito obrigada!

Obrigada à minha família: pais, irmãos, namorado (que sofreu bastante com os ataques de ansiedade!), cunhado e cunhada, sobrinhos, primos, tios e amigos de Mogi Guaçu e Ouro Preto. Vocês são o meu sustento emocional e força para seguir!

Obrigada aos meus amigos do Grupo Plant Traits (Mauro Marabesi, Heloísa Bruno, Fabio Fernandes, Vitor Almeida, Leonardo Hamachi, Deroila Marinho, Lucas Cardinelli, Graziela, Janaína Silva e Josiane Bison) pela ajuda em campo, no laboratório, pelos conselhos, discussões filosóficas e teóricas. Um especial agradecimento ao Renato Belinello (Pezão), um grande amigo e um exemplo! Também, não posso deixar de agradecer aos colegas da Unicamp pelo carinho.

Agradeço imensamente ao Dr. Marcos P. M. Aidar, que foi mais do que um orientador. Obrigada pelos conhecimentos, pela paciência, pelo carinho e respeito! Aos membros da banca de qualificação, pré-banca e banca examinadora de defesa da Tese um grande agradecimento pelas contribuições e melhorias sugeridas ao trabalho. Um agradecimento especial ao Prof. Dr. Tomas F. Domingues, uma pessoa muito especial!

Agradeço ao gestor do Núcleo Santa Virgínia, João Paulo Vilani, e todos os funcionários do Parque. Assim como todos os funcionários do Instituto de Botânica de São Paulo e da Universidade Estadual de Campinas. Agradeço aos proprietários dos fragmentos em São Luis do Paraitinga e região por permitir a coleta de informações e acesso às áreas de estudo. Por fim, agradeço o suporte financeiro oferecido pelas agências de fomento. Agradeço a Capes e CNPq pela bolsa de Doutorado e à Fapesp/ NERC pelo apoio técnico através do Projeto Temático ECOFOR (Processo nº: 12/51872-5, início em 01 de agosto de 2013 a 31 de julho de 2017; Acordo de cooperação internacional BIOTA FAPESP/NERC RCUK).

Enfim, obrigada a todos que fizeram parte dessa etapa!

RESUMO

O processo de fragmentação de florestas vem promovendo grande degradação do bioma Mata Atlântica. Florestas são intensamente convertidas em áreas voltadas para uso antrópico, comprometendo os ecossistemas e as espécies nativas, além de permitir um aumento de espécies pioneiras, invasão por exóticas, alteração dos ciclos biogeoquímicos e da disponibilidade nutricional. Assim, o objetivo principal do presente trabalho foi analisar a funcionalidade de fragmentos de Mata Atlântica enfocando em atributos relacionados às estratégias de uso de nitrogênio. Para alcançar tal objetivo, o trabalho foi subdividido em três etapas: (1) Estudo de meta-análise almejando destacar quais variáveis de uso de nitrogênio são eficientes para distinguir espécies pioneiras de não pioneiras em florestas tropicais e subtropicais; (2) Análise de atributos funcionais em um gradiente de perturbação antrópica e proposta de inclusão da enzima nitrato redutase nessa abordagem; (3) Teste e validação dos índices funcionais em fragmentos de Mata Atlântica, na região de São Luís do Paraitinga, São Paulo. Para a meta-análise, foi realizada uma busca na literatura publicada e não publicada enfocando aquelas que continham informações de uso de nitrogênio para espécies arbóreas pioneiras (Pi) e não pioneiras (NPi) e, em seguida uma análise estatística através do pacote Metafor do programa R. Essa análise demonstrou que a atividade da enzima nitrato redutase (NRA, em inglês) foi eficiente para distinguir entre grupos sucessionais, destacando sua relevância na composição do índice. A NRA tem grande potencial para ser incluída em estudos de atributos funcionais, pois consegue demonstrar com eficiência os grupos, sendo o principal atributo que os distingue. Para avaliar a eficiência dos índices em agrupar as áreas estudadas foram realizadas análises univariadas e multivariadas. Além da NRA, o conteúdo de glutamina e arginina na seiva do xilema e área foliar específica foram incorporados aos índices funcionais, os quais foram ponderados pela área basal relativa da espécie. Os fragmentos demonstraram estratégias diferenciadas quanto ao uso de nitrogênio, destacando o estágio sucessional distinto entre áreas. Os índices funcionais eficientes para separar estratégias aquisitivas, especialmente o índice com NRA. Outros atributos enfocando em estratégias conservativas, tais com densidade da madeira e carbono total, podem ajudar no agrupamento de fragmentos em estágio mais avançado na sucessão.

Palavras-chave: Fragmentos; Nitrogênio; Índice; Enzima Nitrato Redutase; Paisagens degradadas pelo homem; Atributos funcionais.

ABSTRACT

The process of fragmentation of forests has promoted great degradation of the Atlantic Forest biome. Forests are intensely converted into areas for anthropic use, affecting ecosystems services and native species, as well as allowing for an increase in pioneer species, invasion by exotic species, alteration of biogeochemical cycles and nutritional availability. Understanding the conditions of the fragments and their successional status is a basic condition to the development of effective conservation and management policies. Thus, the main objective of the present study is to analyze the functionality of fragments of Atlantic Forest focusing on traits related to the strategies of nitrogen use. In order to reach this aim, the study was subdivided into three stages: (1) Meta-analysis study aiming to highlight which nitrogen use variables are efficient to distinguish pioneer and non-pioneer species in tropical and subtropical forests; (2) Analysis of functional traits in an anthropic disturbance gradient and propose the inclusion of nitrate reductase enzyme in this approach; (3) Test and validation of functional indexes in fragments of Atlantic Forest, in the region of São Luís do Paraitinga, São Paulo. For the meta-analysis, a search of published and unpublished papers was carried out focusing on those that contained nitrogen use information for pioneer (Pi) and non-pioneer (NPi) tree species, and then calculated with Metafor package of the R program. This analysis demonstrated that the activity of the nitrate reductase (NRA) and total nitrogen were efficient variables to distinguish Pi and NPi, highlighting their relevance in the composition of the index. The NRA has great potential to be included in studies of functional traits, because it can efficiently group species, being the main attribute that distinguishes groups. To evaluate the efficiency of the indices in grouping fragments, univariate and multivariate analyzes were performed. In addition to the NRA, the content of glutamine and arginine in the xylem sap and specific leaf area were also collected and incorporated into the functional indexes, which were weighted by the relative basal area of the species. The fragments showed different strategies regarding the use of nitrogen, highlighting the successional stages distinct from the areas. Functional indices are efficient to separate acquisitive strategies, especially the index with NRA. Other traits focusing on conservative strategies, such as wood density and total carbon, could explain the functionality of late secondary fragments.

Key words: fragments; nitrogen; index; nitrate reductase activity; Human-modified landscapes.

LISTA DE ILUSTRAÇÕES

INTRODUÇÃO GERAL

Figura 1. Diagrama conceitual indicando as diferentes estratégias de uso de nitrogênio pelas plantas ao longo da sucessão florestal (Aidar et al., 2003). $\delta^{15}\text{N}$ foliar (%); conteúdo de N na seiva do xilema ($\mu\text{mol mL}^{-1}$); atividade da enzima nitrato redutase – ANR ($\text{pkat g}^{-1}\text{PF}$); conteúdo de N foliar (%); conteúdo de NO_3^- na seiva do xilema (%); NO_3^- - nitrato; Asn - asparagina; Arg- arginina; Gln - glutamina; Outros, outros aminoácidos. Sucessão Inicial.....23

Figura 2. Área de amostragem do projeto ECOFOR FAPESP/NERC RCUK, destacando a região dos fragmentos do presente trabalho (círculo) e as parcelas de floresta madura e secundária (estrelas). Fonte: Dr. André Rochelle, Projeto Fapesp 14/07851-9.....26

CAPÍTULO 1

Figure 1. Overall effect size (diamond) and individual cases' effect size and 95% confidence interval (bar) for nitrogen response variables in tropical, subtropical and temperate forests. (A) Arg – Arginine; (B) NO_3X – content of nitrate in xylem sap; (C) NRAf – Leaf Nitrate reductase activity. The square size represents the relative weight of each individual study in the meta-analysis (influenced by the sample size) and the horizontal line represents the standard deviation.....35

CAPÍTULO 2

Figure 1. ECOFOR sites (BIOTA-FAPESP/NERC-UK Project). O – Old growth forests; S – Secondary forests; and 1 to 14 – Fragments of modified forests. São Paulo, Brazil.....49

Figure 2. Results of the Principal Component Analyses applied to functional traits of tree species from Atlantic forest fragments. A. First and second axis of the PCA. B. First and Third axis of the PCA. LMA= leaf dry mass per unit (g.m^2), LDMC = leaf dry matter content (g.g^{-1}), WD = wood density (g.cm^{-3}), NRA = activity of the enzyme nitrate reductase in the leaf (pkat FW^{-1}) and Asat(a) = photosynthetic rate by unit of leaf area ($\mu\text{molCO}_2\text{m}^{-2}\text{s}^{-1}$).....54

Figure 3. Results of the Principal Component Analyses applied to families from Atlantic forest tree species. LMA= leaf dry mass per unit ($\text{g}\cdot\text{m}^2$), LDMC = leaf dry matter content ($\text{g}\cdot\text{g}^{-1}$), Wd = wood density ($\text{g}\cdot\text{cm}^{-3}$), NRA = activity of the enzyme nitrate reductase in the leaf (pkat FW^{-1}) and Asat(a) = photosynthetic rate by unit of leaf area ($\mu\text{molCO}_2\text{m}^{-2}\text{s}^{-1}$)56

Figure 4. Principal Component Analysis grouped by successional groups. Species represented by (Δ) are defined as Pioneer (P) and those represented by (\bullet) are Non-pioneer species.....56

Figure 5. Cluster analysis of Atlantic forest fragments grouped by their response to four leaf traits (LMA, LDMC, WD NRA, Asat(a)), Euclidian distance and UPGMA ($\text{ccc}=0.666$).....57

Figure 6. Discriminant analysis (LDA) and functional groups highly influenced by nitrate reductase activity enzyme in axis 1 (97.83%). Group I (Yellow), Group II (Red), Group III (Blue) and Group IV (Green) – the group of each specie sampled in the study could be found in Annex 1.....58

CAPÍTULO 3

Figure 1. Conceptual diagram indicating the different strategies of nitrogen use by plants along the forest succession (Aidar et al., 2003). $\Delta^{15}\text{N}$ leaf (%); N content in the xylem sap ($\mu\text{mol mL}^{-1}$); Activity of the enzyme nitrate reductase - NRA ($\text{pkat g}^{-1}\text{FW}$); Leaf N content (%); Content of NO_3^- in xylem sap (%); NO_3^- nitrate; Asn-asparagine; Arg-arginine; Gln-glutamine; Other, other amino acids. Initial Succession - 15 years of regeneration; Mean succession - 25 years and late succession - +36 years of regeneration after abandonment.....75

Figure 2. ECOFOR sites (BIOTA-FAPESP/NERC-UK Project). O – Old growth forests; S – Secondary forests; and 1 to 14 – Fragments of modified forests. São Paulo, Brazil.....78

Figure 3. Cluster analysis of Atlantic Forest fragments in species composition (Jaccard Index and UPGMA agglomeration method – cophenetic correlation: 0.82). The dotted black line indicate the point where groups are separated.....83

Figure 4. Plant traits response in Atlantic Forest fragments and their respective standart deviation. (A) SLA – Specific Leaf Area, (B) NRA – Nitrate Reductase Activity, (C) GLN – Glutamine in the xylem sap; (D) ARG – Arginine in the xylem sap.....84

Figure 5. UPGMA dendrogram-based in four functional indices at eleven fragments. Numbers above branches indicate the Fragment number (ccc:0.74).....86

Figure 6. Principal Component Analysis carried out on eleven sites, characterized by four functional indices (NRAagg, SLAagg, ARGagg and GLNagg). The four functional indices are represented in the vectors.....86

LISTA DE TABELAS

CAPÍTULO 1

Table 1. Studies included in this review. NRA – foliar nitrate reductase activity, CN – carbon, nitrogen ratio, ARG – arginine and NO_3X – nitrate in the xylem sap. (+) means strategies more pronounced in pioneer species and (-) strategies of non-pioneer species and (NA) indicated absent data in the original study.....35

Table 2. Overall effect size, heterogeneity and asymmetry of each variable included in this study.....37

CAPÍTULO 2

Table 1. Description of sites, characterization and specific locations. Fragments – F1 to F14 – are located at São Luís do Paraitinga and Natividade da Serra; Plots S and O are part of Biota Functional Gradient Project and located at Serra do Mar State Park – Santa Virginia Nucleus, São Luís do Paraitinga – São Paulo State – Brazil. Nsp 70% BA – number of species included in the sample (basal area of the species included in 70% of the site total basal area); Alt (m.a.s.l) – altitude – mean sea level (m).....50

Table 2. Functional traits sampled, their respective units, transformation to normality and functional strategies. LMA= leaf mass area, LDMC= leaf dry matter content, WD= wood density, Asat (a) = photosynthetic rate saturated in light and CO_2 by unit of leaf area, NRA= nitrate reductase activity.....53

Table 3. Pearson's correlation between the pairs of variables analyzed, in the upper triangle are the values of the probability of the relations being at random and in the lower triangle the values of the Pearson correlation. LMA= leaf dry mass per unit (g.m^2), LDMC = leaf dry matter content (g.g^{-1}), Wd = wood density (g.cm^{-3}), NRA = activity of the enzyme nitrate reductase in the leaf (pkat FW^{-1}) and Asat(a) = photosynthetic rate by unit of leaf area ($\mu\text{molCO}_2\text{m}^{-2}\text{s}^{-1}$). Gray colors indicate significant correlation.....53

Table 4. Leaf traits response in each functional group. LMA= leaf dry mass per unit (g.m^2), LDMC = leaf dry matter content (g.g^{-1}), WD = wood density (g.cm^{-3}), NRA = activity of the

enzyme nitrate reductase in the leaf (pkat FW-1) and Asat(a) = photosynthetic rate by unit of leaf area ($\mu\text{molCO}_2\text{m}^{-2}\text{s}^{-1}$). Low (*), Medium Low (**), Medium High (***) and High (****) represent the traits values of the species that composes each group. All groups are statistically different.....58

CAPÍTULO 3

Table 1. Criteria for ecological indicators (Dale & Beyeler 2001).....76

Table 2. Sites sampled at São Luis do Paraitinga and surrounding area and their characterization in species composition, structure and location. Nsp 70% BA – number of species included in the sample (basal area of the species included in 70% of the site total basal area); Alt (m.a.s.l) – altitude – mean sea level (m).....78

Table 3. Definitions of abbreviations, acronyms, and units of variables.....81

Table 4. Multivariate analysis of variance test (MANOVA) to demonstrate the differences between fragments regarding their Specific leaf area, nitrate reductase activity, glutamine and arginine content in the xylem sap.....85

Table 5. Functional groups along a gradient disturbance in Atlantic Forest sites. Each group was composed by different number of species and fragments and was characterized by functional indices in Low (*), Medium Low (**), Medium High (***) and High (****).....87

SUMÁRIO

Introdução Geral	15
Ecosistemas tropicais e os efeitos antrópicos	15
Análise da condição dos ecossistemas através de suas espécies e atributos das plantas	18
O uso de nitrogênio e sua diferença ao longo da sucessão	21
Projeto Temático ECOFOR	25
Objetivos	27
Organização dos capítulos	27
Chapter 1: Effective Nitrogen use variables for classifying plant successional stages	29
Abstract	29
Introduction	30
Material and methods	32
<i>Data compilation</i>	32
<i>Calculation of the effect size</i>	33
Results	34
Discussion	38
Conclusion	42
Author contributions	42
Acknowledgements	42
Chapter 2: Leaf nitrate reductase is an important trait for a better characterization of plant functional strategies	44
Abstract	44
Introduction	45
Material and methods	48
<i>Study area</i>	48
<i>Vegetation sampling</i>	50
<i>Statistical analysis</i>	52
Results	52
Discussion	59
Conclusion	63
Acknowledgements	63
Author contributions	64
Annex 1	65

Chapter 3: Nitrogen use strategies are functional to assess tropical forest succession?	72
Abstract	72
Introduction	73
Material and methods	77
<i>Study sites</i>	77
<i>Functional indices</i>	79
<i>Statistical analysis</i>	81
Results	82
Discussion	87
Conclusion	93
Acknowledgements	93
Author contributions	94
Conclusões Gerais	95
Referências bibliográficas	97
Anexo 1	121
Anexo 2	122

INTRODUÇÃO GERAL

Ecosistemas tropicais e os efeitos antrópicos

As florestas tropicais são extremamente importantes para a manutenção das relações ecológicas e funcionais do planeta, uma vez que contribuem com um terço da produtividade e evapotranspiração, além de hospedar mais da metade da biodiversidade terrestre (Malhi et al. 2014). Contudo, nas últimas décadas essas florestas têm sofrido intensas alterações promovidas pelas atividades antrópicas. Segundo Collinge (1996) e Joly et al. (2014) a perda de habitat e o isolamento, associados à conversão de terras para atividades humanas e a superexploração dos recursos, constituem as mais sérias ameaças à diversidade biológica do Planeta. Estudos recentes indicam que uma consequência inevitável das perturbações ambientais, juntamente com as alterações na ciclagem de nutrientes e da distribuição das espécies é o surgimento de “novos ecossistemas”, que diferem em composição e/ou funcionamento dos ecossistemas originais (Hobbs et al. 2009), levando a mudanças significativas e perda da capacidade de prover os serviços ecossistêmicos necessários para a manutenção das civilizações humanas (Steffen et al. 2007).

Anualmente, cerca de um terço das florestas tropicais sofrem desmatamento e se encontram em fase de sucessão secundária (Aide & Grau 2004; Aide et al. 2013). As florestas secundárias representam um tipo de vegetação frequente e dominante em paisagens modificadas pelo homem (em inglês – human-modified landscapes - HMLs; Chazdon et al. 2009a; Gardner et al. 2009).

Até recentemente, as estratégias de conservação eram direcionadas para a manutenção das florestas tropicais maduras e intactas, principalmente através da criação de áreas protegidas (Melo et al. 2013a). Entretanto, as áreas de preservação ainda não se estendem a todas as florestas tropicais maduras (somente 9.8% do bioma tropical no globo permanece dentro dessas áreas protegidas - Schmitt et al. 2009) e elas continuam sofrendo forte influência das atividades humanas no seu entorno (Wittemyer et al. 2008). Diante disso, a ciência da conservação tem buscado entender não somente as florestas intactas em unidades de conservação, mas também essas novas paisagens modificadas pelo homem (Liu et al. 2007). Para esses ecossistemas, um conjunto de questionamentos também deve ser considerado, incluindo a persistência da biota e a definição de estratégias de manejo mais adequadas e efetivas para essas novas condições (Melo et al. 2013; Farah et al. 2017).

No Brasil, o desmatamento atingiu média de 2,6 milhões de hectares por ano no período de 2000 a 2010, principalmente devido ao aumento de áreas disponíveis para agricultura, pastagem e urbanização (FAO 2011). A Mata Atlântica cobria aproximadamente 15% do território brasileiro (cerca de 1.296.446 km²) e abrangia 17 estados: Alagoas, Bahia, Ceará, Espírito Santo, Goiás, Minas Gerais, Mato Grosso do Sul, Paraíba, Pernambuco, Piauí, Paraná, Rio de Janeiro, Rio Grande do Norte, Rio Grande do Sul, Santa Catarina, São Paulo e Sergipe (MMA 2010), contudo sofre fortemente com os desmatamento e perda da biodiversidade, sendo incluída entre os 25 hotspots mundiais, com prioridade de conservação (Myers et al. 2000). Dados da Fundação SOS Mata Atlântica destacaram que no período de 2012 a 2013 houve um aumento de 9% do desmatamento em relação ao período anterior (2011-2012) nos 17 Estados da Mata Atlântica (Fundação SOS Mata Atlântica 2013).

O estado de São Paulo está localizado em uma região de transição entre a Mata Atlântica e o Cerrado (Durigan & Ratter 2006). Originalmente, a Mata Atlântica ocupava aproximadamente 80% do território do estado (Joly et al. 1999), entretanto atualmente restam apenas 12% dessa cobertura florestal e menos de 5% delas representam efetivamente florestas nativas preservadas (Joly et al. 2014), sendo a maioria dos fragmentos menores que 50 ha (Ribeiro et al. 2009). Fundação SOS Mata Atlântica e INPE (2008) concluíram que houve uma redução de 91% do desflorestamento da Mata Atlântica em SP entre 2000 e 2005, em comparação com o período entre 1995 e 2000. Assim como o levantamento de 2012 a 2013, que continuou indicando uma redução da porcentagem de desmatamento total no Estado.

A Mata Atlântica no Vale do Paraíba em São Paulo, após séculos de degradação, mostra sinais de recuperação. A cobertura vegetal mais que dobrou nos últimos 50 anos, sendo equivalente a 30% do território paulista do Vale do Paraíba. A reconstituição gradual e espontânea de parte da floresta após longos períodos de redução da vegetação nativa parece ser resultado de uma convergência de fatores sociais, econômicos e ambientais, caracterizada como “transição florestal” (Farinaci et al. 2013; Silva et al. 2017). Segundo Farinaci et al. (2013), o termo transição florestal se refere a uma alteração das características do uso da terra de um período quando a cobertura florestal estava em uma fase de redução contínua para uma fase de expansão. De acordo com os autores, para compreender as razões dessa expansão é essencial entender o cenário econômico, uma vez que a urbanização e industrialização afetam o êxodo rural e, as florestas abandonadas, passam a sofrer sucessão secundária.

Os fragmentos florestais remanescentes apresentam-se em mosaicos vegetacionais com dimensões e situações de conservação variadas. Alterações relacionadas às condições

climáticas, edáficas, nutricionais, grau de desmatamento ou influência das áreas de entorno (Joly et al. 2014; Ribeiro et al. 2009; Bazzaz & Pickett 1980) afetam na composição e sucessão dos fragmentos. Laurence e Bierregaard (1997) apontaram que os processos de fragmentação e de perda de biodiversidade estão intimamente ligados e podem comprometer processos ecológicos chave, desde dispersão de sementes até condições demográficas. Fatores ligados à fragmentação, tais como o grau de isolamento, forma, área e estrutura dos fragmentos atuam no número de espécies e tamanho das populações, uma vez que interferem nas interações bióticas (Laurance et al. 2000).

Nos últimos anos há um crescente número de estudos que visam monitorar os processos de regeneração e sucessão ao longo do tempo, combinando cronosequência e dinâmica (Chazdon et al. 2007; Lebrija-Trejos et al. 2010b; Norden et al. 2015). Esses estudos confirmam que os fragmentos abandonados podem ter condições diferenciadas, mesmo que apresentem tipos de abandonamentos, desmatamento, idade, tipo de solo e clima semelhantes (Chazdon et al. 2007). Dessa forma, a sucessão não pode ser considerada um processo previsível e unidirecional e sim composto por vias múltiplas de sucessão, resultando em diversos tipos de florestas maduras, contendo espécies e funcionamentos diferentes da original (Chazdon et al. 2007, 2008; Arroyo-Rodríguez et al. 2017). Entretanto, Guariguata e Ostertag (2001) indicam que apesar da imprevisibilidade da composição das espécies devido aos fatores específicos do local, há uma seqüência de eventos e processos que ocorrem durante a sucessão secundária que podem ser modelados e provavelmente serão válidos em uma base global.

A hipótese da Composição Florística Inicial (IFC, em inglês) proposta por Egler (1954) e exposta por van Breugel et al. (2007) propõe que áreas em sucessão secundária após uso agrícola tendem a ser dominadas durante a fase final da sucessão por espécies que estavam presentes no início da sucessão. Ou seja, durante a fase inicial da sucessão é possível encontrar tanto espécies pioneiras quanto não pioneiras, contudo as pioneiras são mais abundantes nessa fase (Gómez-Pompa & Vazquez-Yanes 1981; Tabarelli et al. 1999). Dando continuidade à sucessão, após o fechamento do dossel, o recrutamento de indivíduos das espécies pioneiras torna-se limitado, há alta taxa de mortalidade desse grupo sucessional e o recrutamento de espécies tolerantes a sombra continua (Swaine & Whitmore 1988).

Van Breugel et al. (2007) definiu espécies pioneiras como aquelas com alta demanda por luz para se estabelecer e persistir, tanto na fase adulta quanto durante a germinação e sobrevivência das plântulas, dominando em áreas de clareiras e em vegetação

em sucessão inicial. Em oposição, as espécies classificadas como tardias ou tolerantes a sombra são capazes de se estabelecer e persistir abaixo do dossel das florestas maduras. Além disso, espécies pioneiras apresentam vida curta e as espécies tolerantes à sombra, vida longa.

Espécies pioneiras se beneficiam da fragmentação do habitat e sob efeito de borda (Mesquita et al. 1999; Tabarelli et al. 1999). As condições climáticas e nutricionais advindas desse processo proporcionam uma tendência à queda de indivíduos mais antigos, alta competição com cipós e dominância de espécies adaptadas a solos pobres (Murcia 1995; Laurance et al. 2000). Tabarelli et al. (2004) apontaram que após o desmatamento a área aberta vizinha e o remanescente florestal influenciam-se mutuamente e, geralmente, há perda de biodiversidade, alta mortalidade de indivíduos devido à dessecação e alta irradiação, especialmente na área de borda. Entretanto, essa nova condição também culmina em incremento da taxa de recrutamento e regeneração, com modificação na composição das espécies. Baseados nessa nova condição de abundância e adaptação de espécies pioneiras nos fragmentos, Tabarelli et al. (2012) propuseram o conceito de domínio por pioneiras (pioneer dominated) e permutação de espécies tardias por pioneiras. Este processo foi denominado como “secundarização” por Joly et al. (2014).

Os impactos humanos na Terra são tão intensos que diversos pesquisadores, embasados em registros geológicos e ambientais, sugerem que estamos em uma nova época geológica, o Antropoceno, caracterizado pelas ações humanas na composição e funcionamento da Terra (Steffen et al. 2007, Malhi et al. 2014). Nesse sentido, diante da intensa alteração dos ecossistemas, torna-se fundamental estudar profundamente os fragmentos florestais remanescentes para o seu reconhecimento, quantificação e gerenciamento, inclusive sendo necessário um novo conjunto de ferramentas que possibilitem obter resultados coerentes com as demandas ecológicas atuais (Hobbs et al. 2009).

Análise da condição dos ecossistemas através de suas espécies e atributos das plantas

A ciência que busca entender a biodiversidade e o funcionamento dos ecossistemas tem crescido rapidamente em importância, especialmente após a publicação da Análise Ecosistêmica do Milênio, que destacou a relação entre os efeitos das mudanças climáticas e das alterações dos ecossistemas com bem estar humano (MA 2005). Desde então, o número de estudos enfocando os aspectos funcionais dos ecossistemas tem aumentado, proporcionando uma melhor compreensão da ecologia através das interações dos organismos

com o meio ambiente físico, químico e biológico, inclusive dos padrões e processos ecológicos que os geram (Diaz & Cabido 2001; Petchey et al. 2004; Nock et al. 2016).

Os atributos das plantas são o centro da ecologia funcional. Os atributos funcionais são características, usualmente medidas ao nível de tecido, como folhas, caule ou raízes e que indicam o balanço de carbono, nitrogênio e água da espécie, além de demonstrar seu desempenho no crescimento e sobrevivência (Naeem & Wright 2003) e sua contribuição aos processos ecológicos (Petchey & Gaston 2006).

McGill et al. (2006) e Violle et al. (2007) definiram os atributos funcionais de variadas maneiras. De forma geral, o atributo é uma propriedade do organismo, geralmente mensurada ao nível de indivíduo, usado comparativamente entre espécies (McGill et al. 2006) e extrapolável para escalas ecossistêmicas (Sapijanskas & Loreau 2010). Além disso, é definido como um conjunto de traços que influenciam fortemente o desempenho de um organismo, através de características morfológicas (tamanho da semente, massa corporal, massa foliar por área e densidade da madeira), bioquímicas (isótopos), fisiológicas (concentração de nutrientes, temperatura, potencial fotossintético), estruturais (área basal), fenológicas (longevidade foliar) ou comportamentais (estratégias de alimentação, nível trófico) (Cornelissen et al. 2003; Violle et al. 2007; Pérez-Harguindeguy et al. 2013).

Os atributos funcionais podem ser classificados de acordo com seu tipo (contínuo, categórico, ordinal ou binário) e grau de dificuldade para obtenção (leve – “soft” ou pesado – “hard”). A maioria dos estudos utilizam atributos com maior facilidade e rapidez para coleta e amostragem (“soft traits”) e, apesar de serem, muitas vezes menos correlacionados com as funções específicas, são considerados bons estimadores. Por outro lado, os “hard-traits” são mais acurados, contudo demandam de mais tempo e trabalho para coleta, fato que dificulta a obtenção desses atributos em uma grande quantidade de espécies e regiões do mundo (Lavorel & Garnier 2002; Nock et al. 2016). Nock et al. (2016) destacaram que a escolha de quais e quantos atributos funcionais devem ser analisados em estudos com essa abordagem não é tarefa trivial, afinal diferentes atributos irão resultar em funções variadas no ecossistema. Esses autores sugerem o uso de múltiplos atributos funcionais, contudo o número exato depende dos organismos e das respostas ecossistêmicas que se almeja alcançar. Eles ainda destacam que é recomendável uma seleção prévia dos atributos baseado na literatura, além de se considerar financiamento e infraestrutura para coleta de campo.

O caso mais clássico e dominante em estudos envolvendo estratégias funcionais é o Espectro da Economia Foliar (leaf economic spectrum - LES; Wright et al. 2004), o qual

auxilia na compreensão de tópicos diversos, inclusive das respostas da comunidade vegetal diante das mudanças no uso do solo (Nock et al. 2016). Esse espectro caracteriza um “trade-off” entre funções fisiológicas vitais de aquisição e conservação de recursos (Messier et al. 2017) e pode ser avaliado em folhas, raízes e ramos (Reich 2014). O extremo mais aquisitivo (“fast”) é caracterizado por espécies com alta concentração de nutrientes na folha, altas taxas fotossintéticas e respiração, baixa longevidade foliar e baixo investimento em massa seca por área foliar. No extremo mais conservativo (“slow”) estão incluídas espécies com alta longevidade foliar, altos investimento em construção foliar, baixa concentração de nutrientes, taxa fotossintética e respiração (Wright et al. 2004; Messier et al. 2017).

Lohbeck et al. (2015) apontaram que há duas formas para avaliar os efeitos da biodiversidade nos ecossistemas através da abordagem por atributos funcionais, seja enfocando na diversidade ou na dominância. A análise com foco na diversidade - diversidade funcional (“functional diversity” – FD) - descreve a distribuição das espécies no espaço funcional (Mason et al. 2005) e destaca a redundância de estratégias e competição entre as espécies. A redundância de estratégias é positiva para o ecossistema e indica resiliência, um comportamento altamente associado à manutenção ou recuperação do ecossistema após distúrbio (Laliberté et al. 2010) e uma forma de evitar a perda de espécies (Bihn et al. 2010). Baixa redundância funcional implica que os atributos são rapidamente perdidos quando há perda de biodiversidade (Pillar et al. 2013).

Por outro lado, a abordagem funcional e baseada na dominância é alcançada através de uma análise ponderada dos efeitos dos atributos da espécie na comunidade como um todo, especialmente ponderado pela área basal ou abundância (Community-weighted means - CWM) (de Vries & Bardgett 2016; Garnier et al. 2004). A direção da relação entre CWM e as funções do ecossistema pode ser negativa ou positiva, ou seja, atributos que promovem um aumento na obtenção de recursos (p.e. alta CWM de nutrientes na folha) aumentam as funções do ecossistema, enquanto que valores opostos indicam conservação de recursos e redução das funções do ecossistema (Garnier et al. 2004; Reich 2014). Quando comparado à dominância funcional e a diversidade funcional, estudos recentes tem demonstrado que a primeira é mais importante para demonstrar a produtividade da comunidade (Tobner et al. 2016; Zhang et al. 2017).

A abordagem adotada no presente trabalho foi definida pelo uso da dominância, mais especificamente enfocando nas espécies que representavam 70% de área basal total da comunidade em estudo. A dominância é um fenômeno típico em ecossistemas naturais e com

alta tendência de incremento, diante das pressões antrópicas (Joly et al. 2014; Santos et al. 2008). Dados indicam que somente 1.4% de espécies determinam a maioria das espécies arbóreas e, geralmente, essas são espécies resistentes a distúrbios (pioneiras) (Santos et al. 2008; ter Steege et al. 2013).

Nesse contexto de análise funcional dos ecossistemas, tem se destacado o uso de indicadores e índices ecológicos e funcionais para avaliar a condição do ambiente (por exemplo, como um sistema de alerta precoce) ou para diagnosticar a causa ambiental das alterações (Garnier et al. 2004). Segundo Mueller (1997), indicador é uma ferramenta, composta por um dado individual ou agregado, que permite a obtenção de informações sobre uma dada realidade, sendo apresentado de forma simples, mensurável e lógica. O índice, por outro lado, é um valor agregado que pode conter em seus cálculos os indicadores como variáveis. Ele tem comumente um valor numérico e representa um instrumento para tomada de decisões, uma vez que assimila em seu cálculo bases científicas e métodos adequados (Siche et al. 2007). Assim, para o presente trabalho optamos por utilizar o termo índice por ser mais amplo e constituído por mais componentes.

A informação recolhida por indicadores e índices ecológicos (e ecofisiológicos) também podem ser usados para prever mudanças futuras no ambiente, para destacar ações de remediação, ou através de monitoramento ao longo do tempo para identificar mudanças ou tendências neles próprios (Niemi & McDonald 2004). Segundo Noss (1999), para que o índice seja capaz de englobar todos os ecossistemas e interações, eles devem considerar três componentes da integridade ecológica, dentre eles a composição, a estrutura e o funcionamento. Somado a isso, a régua comparativa do índice deve ter como referência uma área “natural” ou “sustentável”, preferencialmente localizada em Unidade de Conservação, para que as outras áreas tenham uma lógica explicativa (Andreasen et al. 2001). Estudos sugerem que indicadores funcionais representam de forma mais eficiente a variação nos ecossistemas, superando a abordagem tradicional e baseada apenas na identidade de espécies (Petchey et al. 2004; McGill et al. 2006; Cadotte et al. 2011; Nock et al. 2016).

O uso de nitrogênio em árvores ao longo da sucessão florestal

A substituição de espécies durante a sucessão secundária é muitas vezes explicada em termos de adaptações a disponibilidade de luz (Bazzaz & Pickett 1980). A adaptação de espécies ao longo de um gradiente de luz reflete um “trade-off”, sendo que em um dos extremos do gradiente de disponibilidade de luz, encontram-se as espécies de rápido

crescimento com uma rápida aquisição de recursos, as quais prosperam em estágios de sucessão precoce. No outro extremo há as espécies de crescimento lento que conservam os recursos e dominam sob o ambiente de luz fraca e em estágios de sucessão tardia (Reich 2014; Wright et al. 2004). Esse "trade-off aquisitivo-conservativo" também é chamado de "trade-off de crescimento-sobrevivência" (Kobe & Coates 1997) à medida que as espécies aquisitivas investem mais no crescimento, enquanto as espécies conservadoras investem mais na sobrevivência. Os atributos funcionais são usados para definir as estratégias que as espécies adotam ao longo desse contínuo.

As estratégias de aquisição de nitrogênio (N) em florestas tropicais têm importantes consequências para o funcionamento do ecossistema, respostas das plantas às mudanças climáticas e manutenção da biodiversidade (Andersen & Turner 2013). Além disso, a transformação do nitrogênio difere entre sucessões primárias e secundárias (Robertson & Vitousek 1981), com disponibilidade de nitrogênio aumentando durante as fases iniciais da sucessão secundária. Contudo, em estudos envolvendo atributos funcionais pouca atenção é dada para os nutrientes, incluindo o N, sendo que esse somente é abordado como N total ou através da fixação pelas bactérias (Cornelissen et al. 2003).

Os nutrientes no solo influenciam a produtividade e composição das comunidades tropicais. O N, em especial, é importante para a manutenção das espécies tropicais e regula a fotossíntese, podendo ser considerado um elemento limitante ou colimitante, juntamente com o fósforo (Andersen & Turner 2013). As espécies podem assimilar o N de diversas formas disponíveis, incluindo o amônio, nitrato e N orgânico (Lipson & Näsholm 2001), fato que possibilita a coexistência de espécies (Ashton et al. 2010). A assimilação de nitrogênio requer a redução do nitrato a amônio por uma série de etapas, seguida da redução do amônio em aminoácidos. A redução do nitrato em nitrito ocorre no citoplasma das células tanto das raízes quanto das folhas catalisada pela enzima nitrato redutase (NR) (Masclaux-Daubresse et al. 2010).

Comunidades com maior atividade de nitrato redutase (ANR) podem atuar como dissipadores de nitrato e reduzir a taxa de lixiviação de nitratos e acidificação do solo (Rothstein et al. 1996). Apesar das avaliações da ANR nos ecossistemas florestais serem raras (Adams & Attiwill 1982), estudos nos trópicos sugerem que as espécies arbóreas de sucessão precoce possuem maior ANR do que as que estão mais avançadas na sucessão (Aidar et al. 2003). Tang et al. (2012) usou ANR para testar os efeitos do enriquecimento de N no funcionamento e economia nas plantas e sugeriram que a ANR "in vivo" pode variar com a

intensidade da luz, porque a redução de nitrato pode ter que competir com a fixação de carbono para energia sob condições sombreadas (Jiang & Hull 2000). Espécies com alta capacidade fotossintética, como é o caso das espécies pioneiras, a assimilação de nitrato na folha pode ser dirigida primariamente pelo transporte de elétrons da fotossíntese, o que resulta em baixo custo de carbono para a planta (Pate 1980) e evita a fotoinibição (Carelli & Fahl 2006), sendo que a capacidade dos cloroplastos para converter N inorgânico em aminoácidos pode ser considerada uma verdadeira reação fotossintética, da mesma forma que a assimilação de CO₂ (Lea & Miñlin 2003).

A compreensão acerca do uso de N e sucessão na Mata Atlântica foi iniciada por Aidar et al. (2003) (Figura 1), o qual caracterizou um contínuo de estratégias do uso de nitrogênio de acordo com as guildas de regeneração das espécies em Floresta Ombrófila Densa Submontana. Segundo esses autores, as espécies enquadradas na categoria das pioneiras (Pi) apresentam preferência pela absorção e acúmulo do íon nitrato (NO₃⁻), asparagina como o principal aminoácido transportado na seiva do xilema e atividade da enzima nitrato redutase foliar (ANR) relativamente alta. Enquanto as secundárias tardias (St) têm baixa ANR e maior preferência pelo íon amônio (NH₄⁺), representado pela alta quantidade de aminoácidos de remobilização, principalmente a arginina. As secundárias iniciais (Si) têm comportamento intermediário entre as duas categorias anteriores, sendo o transporte via xilema realizado majoritariamente por arginina e glutamina e ANR e conteúdo de N total foliar menor que o grupo das pioneiras.



Figura 1. Diagrama conceitual indicando as diferentes estratégias de uso de nitrogênio pelas plantas ao longo da sucessão florestal (Aidar et al., 2003). $\delta^{15}\text{N}$ foliar (‰); conteúdo de N na seiva do xilema ($\mu\text{mol mL}^{-1}$); atividade da enzima nitrato redutase – ANR ($\text{pkat g}^{-1}\text{FW}$);

conteúdo de N foliar (%); conteúdo de NO_3^- na seiva do xilema (%); NO_3^- - nitrato; Asn - asparagina; Arg- arginina; Gln - glutamina; Outros, outros aminoácidos. Sucessão Inicial – 15 anos de regeneração; sucessão média – 25 anos e sucessão tardia – +36 anos de regeneração após abandono.

O modelo de uso de nitrogênio foi validado em diversos estudos subsequentes que englobam todas as fitofisionomias da Mata Atlântica: Floresta de Restinga (Silva *dados não publicados*), Floresta Ombrófila Densa de Terras Baixas (Campos 2009), Floresta Ombrófila Densa Submontana e Floresta Estacional Semidecidual (Pereira-Silva 2008), Floresta Ombrófila Densa Submontana (Silva 2012), Floresta Ombrófila Densa Montana (Marchiori 2012; Ribeiro 2013) e Floresta Ombrófila Mista (Morena 2015). O modelo também foi corroborado para a Floresta Subtropical Úmida Montana localizada no Parque Nacional de Lamington - Queensland - Austrália (Ribeiro 2013), no qual se observou grande similaridade de gêneros e famílias de espécies que ocorrem na Mata Atlântica, incluindo o gênero *Araucaria* e famílias como Lauraceae, Myrtaceae e Winteraceae.

Erismann et al. (2008) discutiram e contextualizaram o incremento da disponibilidade de N no meio ambiente através da síntese de amônia pelo processo de Haber-Bosch, para uso como fertilizante químico. Segundo esses autores, decorrente desse processo houve grandes mudanças econômicas, climáticas e nutricionais nesse século. Grande parte da amônia produzida artificialmente é utilizada na agricultura como fertilizante e, segundo estudos, cerca de 40% deste é perdido para o meio ambiente para a forma de dinitrogênio atmosférico não reativo (Galloway et al. 2004). Aumento de N reativo na atmosfera influencia as mudanças climáticas e promove uma maior deposição no solo, poluição da água superficial e subterrânea. Assim, entender os padrões da ciclagem de N terrestre é essencial para prever a produtividade das plantas, composição dos ecossistemas florestais, sequestro de carbono, fluxo de nutrientes para ecossistemas aquáticos e perdas para a atmosfera (Galloway et al. 2004, 2008).

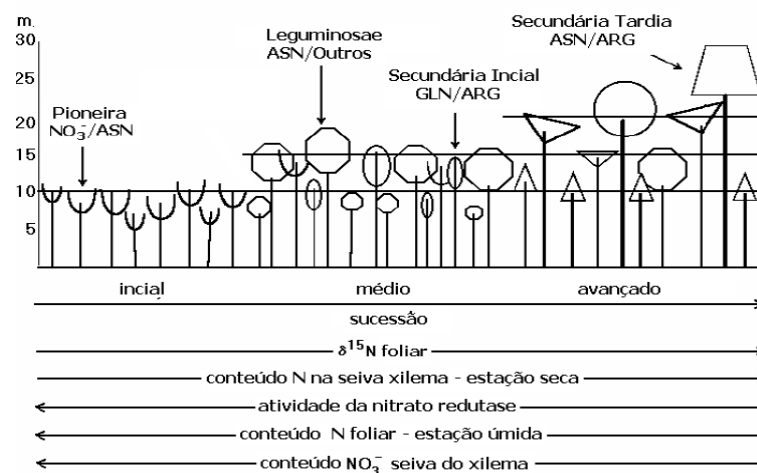
Ao considerar a validade do modelo de uso de nitrogênio para a Mata Atlântica e a tendência de incremento desse nutriente nos ecossistemas, podemos supor que o mesmo pode ser transformado em uma ferramenta para investigar sobre o funcionamento da floresta tropical em diversos cenários. Adiciona-se também a importância de estudos envolvendo fisiologia do nitrogênio, visto sua função limitante para florestas secundárias e passado evolutivo comum entre espécies arbóreas (Raven & Andrews 2010), além da escassez de

estudos aplicados enfocando a sucessão florestal e aspectos funcionais e fisiológicos (Amazonas et al. 2011).

Projeto Temático ECOFOR

Esse trabalho é parte integrante do Projeto Temático Fapesp “ECOFOR: Biodiversidade e funcionamento de ecossistemas em áreas alteradas pelo homem nas Florestas Amazônica e Atlântica (nº do processo: 12/51872-5, início em 01 de agosto de 2013 a 31 de dezembro de 2017; Acordo de cooperação internacional BIOTA FAPESP/NERC RCUK), cujo objetivo geral é entender a influência do impacto das ações antrópicas e da fragmentação de habitat na diversidade e conservação das florestas tropicais, enfocando nos biomas Mata Atlântica e Amazônia.

O conhecimento sobre a estrutura e funcionamento de Florestas Tropicais preservadas é amplo, contudo a extrapolação dos resultados obtidos nesses ecossistemas para florestas tropicais alteradas pelo homem (HMTF, em inglês) é pouco eficiente (Farah et al. 2017). Assim, a proposta desse Projeto Temático foi ampliar o conhecimento sobre essas florestas, que apesar de estarem em ampla expansão ainda são pouco estudadas (Brancalion et al. 2013). Dentre as lacunas de conhecimento que o projeto visa discorrer estão incluídas: i) Impactos das alterações humanas sobre o funcionamento do ecossistema, especialmente ciclagem de matéria orgânica, nutrientes e as relações entre os processos biofísicos, a biodiversidade, o solo e o clima; ii) conectar o funcionamento do ecossistema e caracteres biológicos, que podem fornecer pistas sobre a estabilidade e a resiliência das florestas degradadas; iii) compreender a capacidade de generalização dos dados, isto é, até que ponto resultados obtidos em uma dada Floresta Tropical podem ser extrapolados para florestas em outros continentes; iv) compreender o impacto e as consequências das alterações humanas a nível de paisagem e tempo, multi escalas espaciais e temporais; v) reduzir a distância e o tempo entre a ciência e a tomada de decisão política. A presente tese de Doutorado ajudará a responder, em especial, três grandes aspectos do projeto temático: as lacunas i, ii, iii.

O Projeto ECOFOR visa ampliar os conhecimentos dos efeitos das ações humanas sobre a biodiversidade e a funcionalidade dos ecossistemas, bem como a provisão de serviços ambientais oferecidos por eles. O projeto focou em florestas tropicais alteradas, principalmente por incêndio e corte seletivo, além de comparações com florestas preservadas e estudos intensivos (conjuntos de parcelas do Programa Biota no Parque Estadual da Serra do Mar da porção nordeste do estado de São Paulo, e parcelas na região de Santarém-Belterra na

Amazônia). Incluem-se no Temático, propostas envolvendo levantamentos da diversidade florística e faunística dos fragmentos, bem como o funcionamento abaixo e acima do solo fornecendo subsídios para políticas públicas.

No estado de São Paulo, o desenho experimental do Projeto envolveu um transecto ligando a Serra da Mantiqueira com o Vale do Paraíba do sul (Figura 2), sendo incluídos 16 fragmentos e 32 parcelas (borda e interior). Os fragmentos foram classificados quanto ao tamanho (pequenos <50 ha> grandes), conectividade (conectados e isolados) e classes de altitude 600-900 m e 900-1200 m. O levantamento florístico foi realizado sob a supervisão do Dr. Marcos Assis e Dr. Luis Bernacci e a análise de atributos funcionais foi coordenada pelo Dr. Marcos P.M. Aidar. O projeto temático é coordenado pelo Dr. Carlos Joly e Dr. Jos Barlow.



Figura 2. Área de amostragem do projeto ECOFOR FAPESP/NERC RCUK, destacando a região dos fragmentos do presente trabalho (círculo) e as parcelas de floresta madura e secundária (estrelas). Fonte: Dr. André Rochelle, Projeto Fapesp 14/07851-9.

Acredita-se que os resultados irão contribuir significativamente com o estabelecimento de hipóteses sobre as consequências funcionais de mudanças em comunidades de plantas após alterações humanas em florestas tropicais. Além de aprofundar o conhecimento das florestas brasileiras, o projeto também proporcionará uma análise comparada com o Projeto SAFE, na Malásia (Joly & Barlow 2016).

OBJETIVOS

O presente trabalho tem como objetivo principal utilizar a abordagem de atributos funcionais associados às estratégias de uso de nitrogênio para melhor compreender o funcionamento das florestas tropicais em um gradiente de perturbação antrópica. Dentre os objetivos específicos destacam-se:

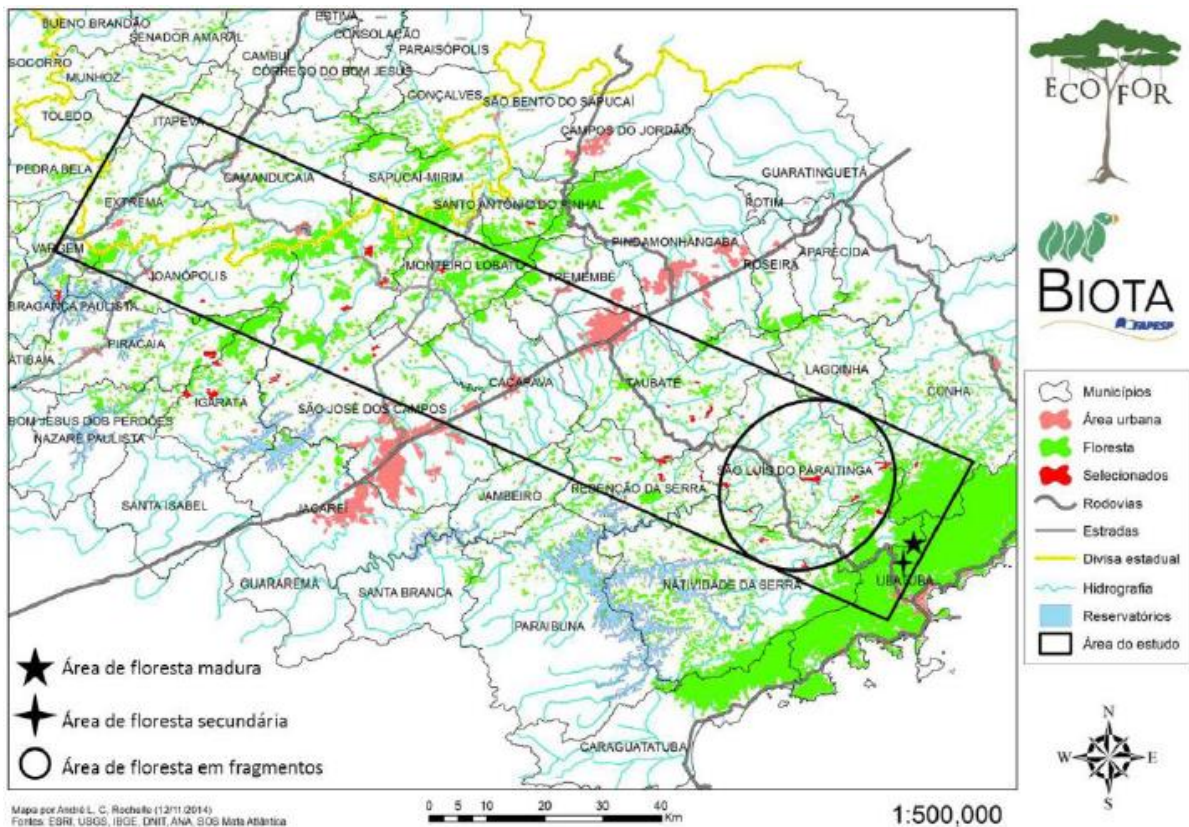
- Avaliar quais variáveis de uso de nitrogênio são importantes na distinção entre as categorias sucessionais pioneiras e não pioneiras;
- Entender como as florestas tropicais, subtropicais e temperadas utilizam o nitrogênio, principalmente enfocando no papel desse nutriente como indicador de estágios sucessionais;
- Caracterizar as principais formas de uso de nitrogênio das espécies dominantes em Floresta Ombrófila Densa, tanto em áreas ocupadas por florestas maduras quanto em fragmentos florestais, avaliando características de aquisição, transporte, armazenamento e remobilização durante a estação chuvosa e relacioná-las com as classes sucessionais e com outros atributos funcionais;
- Verificar o efeito da enzima nitrato redutase na caracterização das estratégias funcionais das espécies estudadas;
- Propor índices ecofisiológicos como ferramenta para classificar estágios sucessionais de florestas, baseados nas estratégias de uso de nitrogênio.

ORGANIZAÇÃO DOS CAPÍTULOS

O capítulo introdutório traz uma breve revisão bibliográfica, abordando conceitos e fundamentos históricos necessários para a compreensão dos principais temas tratados ao longo da tese. Os impactos sofridos pelas florestas tropicais, a sucessão ecológica e o uso de atributos funcionais como ferramenta para se avaliar a funcionalidade dos ecossistemas. Incluiu-se também uma abordagem breve sobre nitrogênio e sua relação com sucessão e funcionalidade, já que esse é o tema central do presente trabalho.

No capítulo 1, buscou-se entender quais variáveis associadas às estratégias das plantas para assimilação e transporte de nitrogênio seriam eficientes para distinguir espécies pioneiras de não pioneiras através da técnica de meta-análise (técnica estatística desenvolvida para integrar resultados de vários estudos independentes sobre o tema em pauta). Esta abordagem busca identificar quais as melhores variáveis em relação ao uso de N em espécies arbóreas tropicais que poderiam nos ajudar a responder os questionamentos propostos nos capítulos 2º e 3º desta tese.

O capítulo 2 busca destacar a atividade da nitrato redutase como um atributo importante para ser incluída em abordagens funcionais, pois percebemos que a atividade dessa enzima tem alta relação com estratégias aquisitivas e estaria bem relacionada tanto com aquisição de nutrientes como crescimento das espécies na comunidade.

No capítulo 3 apresentamos uma nova ferramenta para estudos relacionados com atributos funcionais e sucessão florestal. Sugerimos o uso de índices agregados e ponderados (pela área basal relativa) para agrupar e classificar os fragmentos em estágios de sucessão, baseado principalmente na presença e atividade da enzima nitrato redutase nas espécies das comunidades. Finalmente, apresentamos as considerações finais considerando as principais conclusões do trabalho e perspectivas para estudos futuros.

CHAPTER 1

Effective Nitrogen use variables for classifying plant successional stages

Nidia Mara Marchiori ^{A, D}, Marina Wolowski ^B, Janaina G. da Silva ^A, Marcos P. Marinho Aidar ^C

^A Department of Plant Biology, Institute of Biology, University of Campinas – UNICAMP - P.O.Box: 6109, 13083-970, Campinas, SP, Brazil. <http://www.unicamp.br/>

^B Institute of Natural Sciences, Federal University of Alfenas - UNIFAL-MG, Alfenas, MG, Brazil, Gabriel Monteiro da Silva street 700, 37130-001 - Alfenas, MG – Brazil

^C Department of Plant Physiology and Biochemistry, Institute of Botany – IBOT/ SMA, São Paulo, Brazil, P.O. Box 68041, 04045-972. <http://www.ibot.sp.gov.br/>

^D Corresponding author: nidiamarchiori@yahoo.com.br

In preparation to “Plant Physiology and Biochemistry”

ABSTRACT

Tropical forests are relatively rich in nitrogen (N) and it has the potential to act as limitant or co-limitant in these ecosystems. The climate and land use changes strongly influence the cycle of this nutrient, promoting a large accumulation in the soil and consequent modification in the structure and composition of communities. Plants are generally flexible in their ability to assimilate the chemical forms of N and their efficiency results in different competitive advantages. In addition, studies indicate that there is a pattern regarding its use, a factor that allows the categorization of species in successional groups. The aim of this meta-analysis is to verify if the species can be grouped in successional groups considering the strategy of assimilation and transport of available N. Data were gathered from published and unpublished studies involving the N use strategies (foliar nitrate reductase activity - NRA, arginine content – Arg, nitrate in the xylem sap – NO₃X, CN ratio and total N in the leaf) and were analysed by random-effect models. NRA had low variation between studies and was more effective to distinguish successional groups than the others variables. This reinforced its importance in functional approaches. The content of arginine was higher in non-pioneer species than pioneer species indicating a conservative strategy, as it is considered an important nitrogen reserve, recycling, and used as plant defense. We found significant effect sizes for NRA, Arg and

NO₃X suggesting that, overall, these response variables are useful to distinguish pioneer and non-pioneer species.

Keywords: Plant physiology; Functional groups; Meta-analysis.

INTRODUCTION

Nitrogen (N) is recognized as a key factor in ecosystem functioning, determining plant performance and species distribution (Schimann et al. 2008). The amount and form of soil inorganic N found in communities are important control factors for species distribution patterns, influencing species coexistence or competition (Koyama & Tokuchi 2003). N is usually a limiting factor for plant growth (Russo et al. 2013) and could increase the competition between plants and microorganisms, that depend on this nutrient for growth and synthesis of essential biomolecules, such as ATP, NADH, NADPH, chlorophyll, proteins and enzymes (Harper 1994).

Large amount of N is added into the system by dry and wet deposition or fixation, however, much is lost by leaching, volatilization or denitrification (Vitousek & Sanford 1986). Studies have estimated that 50–70% of the nitrogen provided to the soil is lost (Hodge et al. 2000). The N cycling in the ecosystem are mainly mediated by microorganisms and, thus, suffer influence of seasonal changes, as well as by precipitation, moisture, pH, soil, temperature, vegetation composition and successional stage of the forest (Tanner et al. 1998).

The ability of a plant to capture nitrogen from the soil depends on soil type, environment and species. Mineralization and nitrification processes are vital for plant nutrition and N may be available to plants in various forms, including ammonium (NH₄⁺), nitrate (NO₃⁻) and organic molecules that are absorbed differently by roots or leaves (Paungfoo-Lonhienne et al. 2008; Kraiser et al. 2011). In general, plants found in low pH soils, as those in mature forests, tend to take up ammonium or amino acids, whereas plants adapted to acid and more aerobic soils prefer nitrate (Maathuis 2009). The NH₄⁺ assimilation requires less energy than that of NO₃⁻, however most species develop toxicity symptoms when grown on moderate to high levels of NH₄⁺ (Britto et al. 2001). While nitrate is not toxic, but is generally in low abundance in the soil, in part, due to its high solubility and predisposition to leaching, and its rapid acquisition by bacteria and fungi (Roycewicz & Malamy 2012)

The preference of N form could result in different competitive advantages (Smirnoff & Stewart 1985) and species coexistence (Russo et al. 2013), however, it is not yet known why some species become specialist in one specific form of N, or whether if this strategy changes among ecosystems, soil types or functional plant groups (Russo et al. 2013). Raven and Andrews (2010) argue that there are relatively few nutrition-related innovations that arose in the “Tree life style” and concluded that many aspects of the evolution of tree nutrition that need further investigation. Rennenberg and Schmidt (2010) suggest that perennial plants have evolved nutritional features to adapt to nutritional limitation, but it is evident that sustainability and productivity of forests ultimately depend on ecosystem biogeochemistry and properties of tree species for efficient acquisition, use and cycling of nutrients. Studies held in Australia (Stewart et al. 1988) and Brazil (Aidar et al. 2003) pointed that there are patterns regarding the use of nitrogen, a factor that allows the categorization of species in successional groups. According to them, pioneer species are those that present high rates of activity of the enzyme nitrate reductase and are predominantly assimilators in the leaf, whereas late stages species reallocate amino acids and have preference for the ammonium ion (NH_4^+), besides the high CN ratio and low NR activity.

The availability of nitrogen for long periods of time tends to encourage soil nitrification, and consequently cause an acidification and loss of cations. In addition to the global enrichment of N, changes in the composition due to deforestation has led to strong changes in community structure, reduction of species richness and loss of biodiversity in several terrestrial biomes (Robbink et al. 1998; Gough et al. 2000; Xia & Wan 2008). It is well known that pioneer species benefit from habitat fragmentation and border effect (Mesquita et al. 1999; Tabarelli et al. 1999; Joly et al. 2014), including in the microclimatic and nutritional conditions brought by this new environmental condition, leading to fall of older individuals, high competition with vines and dominance of species adapted to poor soils (Laurance et al. 2000), but is incipient the knowledge about the plant functionality after disturbances.

Idol et al. (2003) investigated N mineralization, and nitrification across a chronosequence (1, 6, 12, 31, and 80–100 years) of upland hardwood forest stands in southern Indiana, USA. In opposition to the majority of studies, their results showed that harvesting has no influence on N mineralization. However, the authors presented suggest that mineralization could increase just after the harvesting and, after 1- 3 year, this process tend to decline. They

also found that the highest rates of N mineralization, nitrification, and N uptake were in the mature forest.

Several studies indicate that fossil fuels burning, the release of N by industries, intense cultivation of species with natural N fixation and the use of fertilizers (Galloway et al. 2004) have already doubled the rate of N entry in terrestrial ecosystems. The consequences of such deposition are especially known for temperate forests and indicate that the initial response to this deposition would increase photosynthetic rates and carbon sequestration (Högberg 2012).

In this sense, it is essential to understand the ability of N to act as a tool to characterize successional groups, especially considering the enrichment of N, changes in the soil use and the possible effect on the composition and functionality of the plant community. For this, we seek to answer the following questions: (1) Response variables associated with the assimilation and transport of nitrogen are good predictor of plant successional stage (i.e. pioneer versus non-pioneer species?) and (2) Does this distinction between groups by N use strategies vary between tropical, subtropical and temperate forest?

MATERIAL AND METHODS

Data compilation

We collected data from published peer-reviewed papers, thesis and unpublished data that tested the effects of nitrogen use strategies by plants to distinguish plant successional groups. The studies were only included in the meta-analysis if they had at least one species (with at least two individuals) from pioneer successional group and one from non-pioneer. If the information about the successional group of the species was not presented we conducted a deep search in other peer-reviewed papers to define it. In addition, the experiments should be done at tropical or subtropical forests, in the field or in the greenhouse.

The variables included in the meta-analysis were: leaf nitrate reductase activity (NRA_f), nitrate in the xylem sap (NO_3^-), arginine in the xylem sap (Arg), total nitrogen in the leaf (N) and carbon: nitrogen ratio (CN). These variables were chosen because they represent pioneer strategies (NRA_f , NO_3^- and N) and non-pioneer strategies (Arg and CN) based on the model proposed by Aidar et al. (2003). The units of the variables and the sample technique of each study do not interfere in the calculation of the effect size, which is the statistical measure used in the meta-analysis.

We conducted the literature review using the Web of Knowledge (Thomson Reuters, Philadelphia, PA, USA) between November 2014 and October 2016. We used the following key-words combination: nitrogen metabolism AND regeneration guilds; nitrate reductase AND forest AND regeneration; nitrogen metabolism AND regeneration guilds AND forest; nitrate reductase AND secondary species. We got 19,841 articles published from 2000 to 2014. We refined our search by excluding articles containing the following terms: water, animal, marine, medicine, river, plankton and dinoflagellate. Thus, our search resulted in 642 articles, which were then refined again by reading the abstract and the methods, resulting in 12 studies. We excluded species classified as early secondary in the succession in this meta-analysis.

Calculation of the effect size

The effect size is the unit of measure in a meta-analysis. It reflects the magnitude of the treatment effect or the strength of a relationship between two variables (Borenstein et al. 2009). In this case we used effect size to assess the difference between pioneer and non-pioneer species in relation to N variables. The effect size was calculated using the standardized mean difference (Hedges' g). The average value of each response variable, standard deviation and sample size were used to calculate the effect size between pioneer and non-pioneer species. These values were extracted from the text, tables or figures, or calculated from reported values of standard error and number of replicates reported in the primary studies. Studies lacking variance estimates or number of replicates were not included in the meta-analysis. Effect size and 95% confidence interval were calculated with metafor package in the R environment (Viechtbauer, 2010).

To calculate the overall effect size for each response variable, we used random-effects models because we assumed that there was some unexplained variation in effect sizes among studies (Borenstein et al. 2010; Harrison 2011). Significance difference between groups was identified by comparing the heterogeneity within and between groups. The evaluation of heterogeneity is importance in the meta-analysis, since the absence or presence of heterogeneity indicates the model more suitable to be used (Mazin & Martinez 2009). The heterogeneity is generally assessed by the Q test proposed by Cochran (1954) or quantified by the I^2 statistic defined by Higgins & Thompson (2002). The differences between groups are reported statistically significant at $p < 0.05$. When the 95% confidence interval did not encompass zero, the successional groups was considered statistically different. We determined

the direction (positive, negative) of the effects of each univariate N variable (NRA_f , N, CN, NO_3X , Arg). The study-level treatments were grouped into negative or positive effect factors depending on N use model, proposed by Aidar et al. (2003).

We used a funnel plot and asymmetry test to detect bias (Egger et al. 1997). The funnel plot is a very simple tool and highly influenced by sample size. Each point in the graph represents a study and the symmetry can be assessed by statistical methods. Sources of asymmetry can be the publication bias - the tendency for studies with positive results to be more frequently published than studies with negative/non-significant results. English language bias — the preferential publication of “negative” findings in journals published in languages other than English — makes the location and inclusion of such studies less likely. Methodological quality bias - smaller studies are, on average, conducted and analyzed with less methodological rigor than larger studies (Egger et al. 1997).

RESULTS

Twelve studies (46 cases) were used in the meta-analysis, including three Master thesis, four Doctorate thesis and four peer-reviewed papers. Among them, nine studies were carried out in Brazil, in the Atlantic Forest domain at different physiognomies – Montane, Lower Montane, Lowland Ombrophylous Forest and Semideciduous forest (Veloso 1991; Joly et al. 2012). The other studies were carried out in Subtropical Forests in Australia (three studies). The details about the forest type, deciduousness and altitude are available in Table 1.

The lack of normal distribution ($W = 0.76$, $p\text{-value} < 0.001$) of all effect sizes was influenced by the low sample size of some studies and by the different magnitude of variables, that is, while NRA_f average was $366.6 \text{ pkat.g.FW}^{-1}$, Arg content was 3.56%. Even using the influence plot to remove outliers, we still could not recovering the normal distribution. Thus, we decided conducted one meta-analysis for each response variable (Figure 1). Considering each variable, we did not get normal distribution for Arginine, CN ratio and total N (Table 2). We will present the forest plot for Arginine (even it did not follow normal distribution), nitrate in the xylem sap and nitrate reductase activity.

Table 1. Studies included in this review. NRA_F – foliar nitrate reductase activity, CN – carbon, nitrogen ratio, ARG – arginine and NO_3X – nitrate in the xylem sap. (+) means strategies more pronounced in pioneer species and (-) strategies of non-pioneer species and (NA) indicated absent data in the original study.

AUTHOR	YEAR	TYPE OF PUBLICATION	FOREST	COUNTRY	DECIDUOUSNESS	ALTITUDE	NUMBER				
							OF SPECIES	NRAF	CN	ARG	NO3X
Aidar et al.	2003	Paper	Lower Montane Tropical Forest	Brazil	Evergreen	590	8	+	-	-	+
Campos	2009	Master thesis	Lowland Tropical Forest	Brazil	Evergreen	76,5	22	+	-	-	+
Marchiori	2012	Master thesis	Montane Tropical Forest_secondary	Brazil	Evergreen	1200	28	+	-	-	+
Oliveira et al.	2017	Paper	Semidecidual Tropical Forest	Brazil	Deciduous	600	6	+	-	-	+
Pereira_Silva	2008	Doctorate thesis	Lower Montane Tropical Forest	Brazil	Evergreen	400	12	+	-	-	+
Pereira_Silva	2008	Doctorate thesis	Semidecidual Tropical Forest	Brazil	Deciduous	670	18	+	-	-	+
Ribeiro	2013	Doctorate thesis	Montane Tropical Forest_Mature	Brazil	Evergreen	900	26	+	-	-	+
Ribeiro	2013	Doctorate thesis	Subtropical Forest	Australia	Evergreen	700	16	+	-	-	+
Silva	2012	Master thesis	Lower Montane Tropical Forest	Brazil	Evergreen	123,5	22	+	-	-	+
Stewart et al.	1988	Paper	Subtropical Forest_Mature	Australia	Evergreen	640	13	+	-	-	+
Stewart et al.	1988	Paper	Subtropical Forest_Secondary	Australia	Evergreen	900	13	+	-	-	+
Stewart et al.	1992	Paper	Semidecidual Tropical Forest	Brazil	Deciduous	935	19	+	-	-	+

A

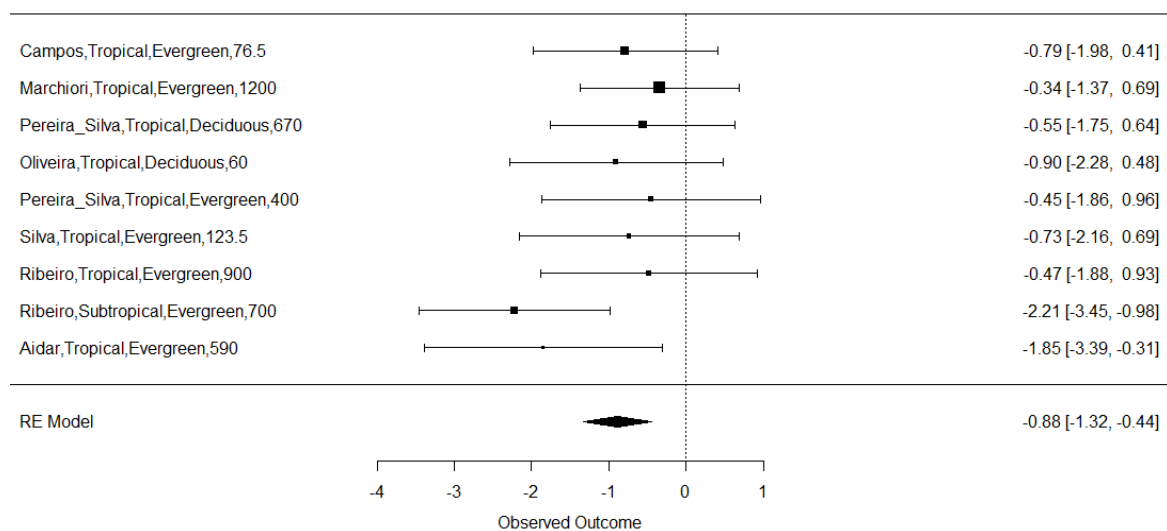

B**C**

Figure 1. Overall effect size (diamond) and individual cases' effect size and 95% confidence interval (bar) for nitrogen response variables in tropical and subtropical forests. The studies names include the surname of the first author, the forest type and altitude. (A) Arg – Arginine; (B) NO_3X – nitrate content in xylem sap; (C) NRA_f – Leaf Nitrate reductase activity. The square size represents the relative weight of each individual study in the meta-analysis (influenced by the sample size) and the horizontal line represents $\pm 1.96 \times$ standard deviation.

Successional groups were distinguished by the nitrogen variables, NRA_f and NO_3X . However, we did not find difference among forests types, neither the influence of deciduousness. The overall effect size from random effect sizes method is presented in Table 2, as well as the heterogeneity and the number of cases considered for each variable.

Table 2. Overall effect size, heterogeneity and asymmetry of each variable included in this study.

VARIABLE	NUMBER OF CASES	RESIDUALS			
		SHAPIRO-WILK TEST	OVERALL EFFECT SIZE	HETEROGENEITY	ASYMMETRY
Arginine - ARG	9	0.796 (p=0.018)	-0.881 (p<0.001)	8.071 (p=0.426)	-0.818 (p=0.413)
CN ratio - CN	7	0.695 (p=0.003)	20.182 (p<0.001)	1.288 (p=0.972)	-0.629 (p=0.533)
Total N (leaves) - N	11	0.411 (p<0.001)	1.337 (p<0.001)	26.254 (p=0.003)	3.8602 (p<0.001)
Nitrate in the xylem sap - NO ₃ X	8	0.961 (p= 0.817)	1.371 (p<0.001)	19.743 (p=0.006)	1.536 (p=0.124)
Nitrate reductase activity - NRAf	13	0.965 (p=0.827)	3.613 (p<0.001)	106.832 (p<0.001)	4.984 (p<0.001)

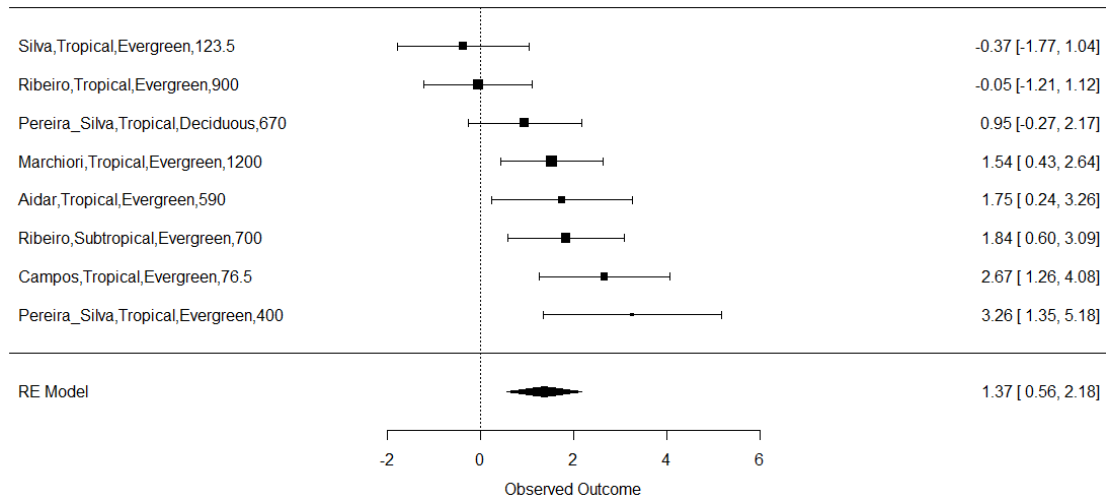
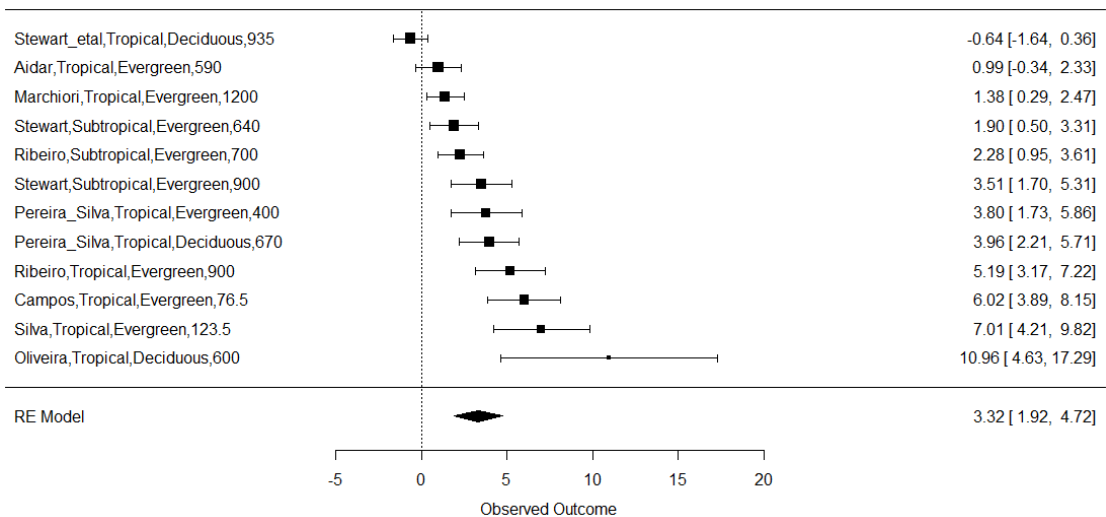
The overall effect size for arginine demonstrated that it is possible to distinguish between pioneer and non-pioneer strategies ($Z = -0.88$; $p < 0.001$), however this was not a pattern for all studies, especially for the studies conducted in the Brazilian Atlantic Forest (Campos 2009, Marchiori 2012, Pereira-Silva 2008, Silva 2012) (Figure 2A). In addition, the negative value of overall effect size indicate that arginine tend to be higher in non-pioneer species. The effect size in meta-analysis is affected by the species number, average and standard deviation and, the high deviation found in arginine content could explain the no significant individual case results.

We noticed that the average of the arginine content in non-pioneer species was four times greater than the content in pioneer. Also, Pereira-Silva (2008) found that in late secondary species the xylem sap amino acids were predominantly asparagine and arginine. Silva (2012) found that arginine content was low or null in some species, however always higher in late secondary species, Campos (2009) corroborated the previous results with high asparagine and arginine in winter, and asparagine and glutamine in summer in late secondary species. Finally, Marchiori (2012) found that the content of arginine was different between early secondary species and late secondary species ($F = 3.4$ $p = 0.03$). Additionally, there was no evidence of heterogeneity among the studies ($Q(df = 8) = 8.07$, $p = 0.43$), also evident by low value of I^2 test (5.48%), probably because of the low number of studies included in the meta-analysis. According to Higgins et al. (2003), when I^2 test result is below 20% it represents a low heterogeneity. However, Arginine did not follow normal distribution and statistics used depend on this, so we can only suggest a trend in these results.

The overall effect size for the content of nitrate in the xylem sap (NO₃X) demonstrated that is possible to distinguish pioneer and non-pioneer strategies using this variable, and it is also represented to be dominant in pioneer species ($Z = 1.37$, $p < 0.001$). The heterogeneity was statistically significant ($Q(df = 7) = 19.74$, $p = 0.0062$) and moderate

($I^2 = 65.76\%$). The funnel test demonstrated a symmetric distribution of the studies (test for funnel plot asymmetry: $z = 1.54$, $p = 0.13$) and low bias of publication. We could find difference between groups even for studies with high variance (Marchiori 2012, Aidar et al. 2003, Campos 2009 and Pereira-Silva 2008). Ribeiro (2013) found a significant difference between nitrate in the xylem sap of pionners and late secondary species, however the author did not considered the season and, because of the low content of nitrate in the summer, this significant statistics could change if is considered only summer. For instance, Silva (2012) found no statistical difference in nitrate xylem concentration between pionner and late secondary species in summer (Figure 2B).

The foliar nitrate reductase activity (NRA_f) had a positive overall effect size ($z = 3.3$, $p < 0.001$). The heterogeneity between studies was significant and very high ($Q(df = 11) = 84.00$, $p < 0.001$; $I^2 = 88.49\%$) and the asymmetry was significant ($z = 6.16$, $p < 0.001$), indicating a bias. This bias could be due to low sample size and the great quantity of positive significant studies. The prevalence of funnel plot asymmetry may provide a useful proxy measure to examine the prevalence of biased analyses in the literature (Eggler et al. 1997). The NRA_f was not distinguish between successional groups only in the study of Stewart et al. (1992) due to higher NRA_f in non-pioneer species and Aidar et al. (2003) due to high standard deviation within group and the great availability of nitrogen to plants (eutrophic soil) (Figure 1C).

Comparing the variables, we noticed that, for NRA_f , the cases had similar weight to the overall effect and small deviation, represented by the square size and interval lines, respectively. On the other hand, the content of arginine in the species xylem sap varied a lot and studies with greater sample size had more influence in overall effect size.

DISCUSSION

In this review, we assessed the variation in nitrogen use strategies across species to identify which one is more efficient to distinguish pioneer and non-pioneer species. Finally, we will return to the ecology and discuss the importance of N strategies for the performance of plants in the field and successional stage. In accordance to nitrogen use model (Aidar et al. 2003), NRA and NO_3X followed the model and were higher in pioneer species. Arginine is highly related to late secondary strategies, especially due to accumulation of N in

relation to C. Unfortunately, it was not possible to join all variable in a unique meta-analysis, but we still obtained a summary of results and reinforced some previous hypotheses.

Under natural conditions, nitrogen availability depends on climate, soil type, vegetation and microenvironment (Vitousek & Matson 1988; Maggs 1991; Smith et al. 1998; Silver et al. 2000). In addition, the nitrogen composition may vary over time (Maithani et al., 1998) and respond to disturbances (Vitousek et al. 1989). Both the amount and the form of nitrogen affect tree growth by their pattern of nitrogen uptake. Nitrate and ammonium are the major inorganic forms of nitrogen taken up by plant roots (Marschner 1995). Ammonium can be readily assimilated into amino acids, but nitrate has first to be reduced to ammonium via nitrate reductase followed by nitrite reductase (Masclaux-Daubresse et al. 2010).

Davidson et al. (2007) found that nitrogen tends to be lost more easily just after the deforestation, by volatilization and leaching. However, along the secondary succession progress, there is an increase in foliar N, as well as in the litterfall and NO_3^- in the soil as the biogeochemical cycle return to the former equilibrium. The study conducted by Rice and Pancholy (1972) showed a higher concentration of ammonium in the soil of late secondary pastures and nitrate in initial sites, probably due to floristic composition and their influence in the nitrification. Britto et al. (2001) highlighted that ammonium toxicity is especially problematic in areas with intensive agriculture and cultivation of livestock, where high levels of NH_3 emission, and subsequent NH_4 deposition, are observed.

Studies on changes in nitrogen composition after burning and short cutting have also reported an increase in soil mineralization and nitrification after soil use (Matson et al. 1987; Attiwill & Adams 1993). According to these authors, after deforestation there is an increase in temperature and humidity, factors that influence litter decomposition and culminate in increased N availability in the soil, in nitrate form (Reynolds et al. 2000; Hope et al. 2003). Stewart et al. (1992) also found great nitrate reductase activity in areas of disturbance. However, some studies oppose this hypothesis, stating that in some forests the selective cut does not alter the availability of nutritional resources (Westbrook et al. 2006, Jerabkova et al. 2006). In this sense, knowing the peculiar characteristics of each forest, such as climate, vegetation, post-disturbance recovery time and land use history is essential to understand the consequences of environmental changes in nutrient availability and community behavior (Pérez et al. 2009). In addition, most studies with tropical forest species focused on the amount of N and little emphasis have been given on quality or which exactly is the preferred resource for functional groups (Norisada et al. 2005).

Species adapted to a specific successional stage are also adapted to an N form available to them and the enzymatic system for N uptake and incorporation should reflect the form of nitrogen used. Lensi et al. (1992) have suggested the importance of floristic composition in nitrification. Nitrate is considered a primary source for the availability of nitrogen in the soil and is assimilated by plant (Beevers & Hageman 1969). In this way, species that are exposed to nitrate availability as a resource present high nitrate reductase activities (NRA). Therefore, *in vivo* NRA is an important indicator of plant NO_3^- use (Koyama & Tokuchi). The enzymes involved in N uptake reduce nitrate assimilated by plants in two ways, by converting nitrate to nitrite with the enzyme nitrate reductase and nitrite into ammonium by nitrite reductase. Then, ammonium is converted into glutamine, which can be used as building material for other amino acids (Foulks et al. 2009). Ammonium may be toxic to plants and nitrate is easily transported in the plant and can be reduced both in leaves and roots (Olsson et al. 2003), while ammonium can be rapidly assimilated into amino acids, especially glutamine and then storage as arginine (Foulks et al. 2009). Oliveira et al. (2017) found that NH_4^+ treatment reduced the total chlorophyll contents of *T. micrantha*, *H. popayanensis* and *G. kunthiana* leaves, showing the toxic effect of NH_4^+ on them.

The regulation of NR (nia) gene expression is very complex and influenced by nitrate and reduced nitrogen forms (Pistorius et al. 1976), sugars (Cheng et al. 1992), light and circadian rhythm (Becker et al. 1992). NR genes in plant leaves appear to be repressed by nitrate-derived nitrogen products (Wilkinson & Crawford 1993). In the leaves, the energy needed to reduce nitrate and subsequently to proceed the assimilation of ammonium into glutamate is directly provided by the light reactions of photosynthesis (Wallsdrove et al. 1983). On the other hand, when the assimilation occurs in the roots, the carbohydrate synthesized in the photosynthesis is translocated to the root where it is used to generate NAPH and ATP. According to Gutschick (1981), the reduction of nitrate in the leaves is energetically more economical, since the anaerobic respiration, the main type in the roots, produces less energy and high carbohydrate consumption, reducing the ATP availability to nitrate reductase. Thus, the nitrate reduction in leaves is the most used strategy in tree species under natural conditions and with no light limitation, especially if nitrate is available. This is a less costly strategy with great competitive advantages (Smirnoff et al. 1984). Stewart et al. (1988; 1990) found low levels of NRA in the roots and branches of most closed forest species, but high NRA in pioneer species.

Nitrification in disturbed areas tend to be high and, therefore, the NRA may be an indicator for the successional group of a species but also of the succession status of a community (Aidar et al. 2003). However, we did not record variation between studies with different past use for all variables investigated. The study of Ribeiro (2013) and Marchiori (2012) were both conducted in montane Atlantic Forest, at plots with different past uses: Ribeiro (2013) in old-growth forest and Marchiori (2012) in secondary forest, short-cuttet for more than 40 years ago. Considering these two forests, Arginine was not efficient to distinguish groups, NO_3X in Marchiori (2012) and NRA_f in both studies. Studies in Australia had their successional groups distinct by Arg (Ribeiro 2013), NO_3X (Ribeiro 2013) and NRA_f (Ribeiro 2013, Stewart et al. 1988). Species located on forest fragments or gaps, the NRA were generally high, even higher than those found in species growing in intact forests (Stewart et al. 1992, Stewart & Orebamjo 1983; Stewart et al. 1988, 1990). The low rates of nitrate reductase in intact forests may reflect the low induction of the enzyme, either by the reduced availability of nitrate in the soil, limitation by the light energy or by the predominance of the assimilation by the root.

There is a strong relationship between NRA and nitrate in the xylem (Lodhi et al. 1988). However, we did not find the same response for these two variables along studies. While NRA was efficient to distinguish between groups in almost all studies, except in Aidar et al. (2003) due to high variance between groups, nitrate did not contrast pioneer and non-pioneer species in Silva (2012), Ribeiro (2013), Pereira-Silva (2008). Nitrate is not only a potential source for organic N biosynthesis, but also plays an important role in osmotic adjustment with adequate N supply (Song et al. 2006). Song et al. (2006) investigated the nitrate in nutritional and osmotic roles in tree growing in different salinity and dry conditions and found higher concentration of NO_3^- and a lower concentration of amino acids in osmotic adjustment under high salinity, influencing the species distribution and success.

Studies involving the assimilation of inorganic nitrogen in conserved Australian forests (Stewart et al. 1988) and open forest plants (Stewart et al. 1990) have found that pioneers or colonizing tree species have high ability to assimilate nitrate ions in their leaves, while non-pioneer species had low nitrate reductase activity and also had a low capacity to use nitrate even when these ions were widely available (Stewart et al. 1988). Oliveira et al. (2017) found that seedlings of late successional species were able to grow in the presence of NO_3^- as the sole N source and suggested that, besides the successional status approach, results

of nitrogen use by species might also be related to other aspects, such as resource use partitioning and niche complementarity.

Arginine is one of the 21 proteinogenic amino acids and has the highest nitrogen to carbon ratio. It serves as an important nitrogen reserve and recycling, and even several steps of arginine biosynthesis still remain poorly characterized in plants, it is already known its role as a precursor for polyamines and nitric oxide (NO) and an essential metabolite for many cellular and developmental processes (Winter et al. 2015). Arginine may be also used as “defense” mechanisms against stress (Winter et al. 2015).

Using the key words “Nitrate reductase AND plants”, in the database Science Direct during the last 10 years (2010-2017), we found 4,906 results. None of these studies highlighted the ecological importance of NRA, but they demonstrated that NRA is associated to many plant process. The transductional and genetic pattern from this enzyme is well-know. Therefore, this meta-analysis is a new approach and could indicate nitrogen use strategies by tropical and subtropical tree species in an ecological and successional perspective.

CONCLUSION

This meta-analysis showed that leaf nitrate reductase activity and nitrate in the xylem sap are efficient to distinguish successional groups and reinforced its importance in functional approaches, especially for pioneer species, reinforcing previous hypotheses. The content of arginine was negative, indicating high contents in non-pioneer species as a conservative strategy. We also highlight that there is a lack of studies on the relationship among successional groups and nitrogen, especially involving amino acids transportation on the xylem sap.

AUTHOR CONTRIBUTIONS

N.M.M., M.W. and M.P.M.A planned and design the criteria and statistics for the meta-analysis, J.G.S. contributed with data and N.M.M. and M.P.M.A wrote the manuscript, with contributions from all authors.

ACKNOWLEDGEMENTS

The following authors thank the following grants for support: N.M.M and M.P.M.A. (Capes, CNPq 142321/2015-0 and Fapesp 2012/51872-5) and M.W. (Fapesp -

2013/15129-9). In addition, we wish to thank the following those who made valuable suggestions or who have otherwise contributed to the preparation.

CHAPTER 2

Leaf nitrate reductase is an important trait for a better characterization of plant functional strategies

N.M. MARCHIORI ^{A, D}, M.A. MARABESI ^A, D. MARINHO ^B, F. FERNANDES ^B, H.B. BRUNO ^B, L. HAMACHI ^B, S.L. RIBEIRO ^C and M.P.M. AIDAR ^B

^A Department of Plant Biology, Institute of Biology. P.O.Box: 6109, University of Campinas – UNICAMP - 13083-970, Campinas, SP, Brazil. <http://www.unicamp.br/>

^B Department of Plant Physiology and Biochemistry, Institute of Botany, São Paulo, Brazil, P.O. Box 68041, 04045-972, São Paulo, SP, Brazil. <http://www.ibot.sp.gov.br/>

^C Department of Botany, Institute of Biosciences, University of São Paulo (USP), São Paulo, SP

^D Corresponding author: Me. Nidia Mara Marchiori – nidiamarchiori@yahoo.com.br

In preparation to “New Phytologist”

ABSTRACT

The highly biodiverse Tropical Forests environments represent the largest contribution to Earth’s productivity, but they are extremely threatened by human activity. Plant functional traits could represent ecological strategies and determine the response of plants to environmental factors. However, nitrogen is usually addressed in plant traits approaches in the form of dry mass basis total N. We propose the inclusion of the nitrate reductase activity as a functional trait to evaluate N uptakes by the plants. We compared five specific traits in two preserved sites and 14 fragments with different past use in the Brazilian Atlantic Forest, totalling 219 tree species of trees and 526 individuals sampled. Three traits were related to structure, plant growth and water use (Leaf dry mass per unit area-LMA, Leaf Dry Matter Content-LDMC and wood density-WD), one trait was related carbon assimilation (Light saturated net photosynthetic rate, area basis-Asata) and one to nutrient/ nitrogen assimilation (Nitrate reductase activity-NRA). Results showed differences along functional groups, families and successional groups and correlation between almost all traits sampled. Most traits that were measured could be correlated in the Leaf Economic Spectrum (LES) dimension, NRA was significantly correlated to LMA (-0.267%), WD (-0.211%) and Asat(a) (0.241%),

as was LDMC to LMA (0.389%), WD (0.505%) and Asat(a) (-0.318%). NRA was the main trait responsible for the distinction of plant functional traits at Atlantic Forest fragments compared to other traits, which had a gradient of response but not as clear as NRA based on multivariate analysis. Therefore, NRA should be added in leaf traits studies, especially because it is a soft trait, easily measured in the field and with a high potential to highlight “fast” or acquisitive species or strategies (pioneer or early successional). Supported by Biota-FAPESP/NERC-RCUK.

Key words: rainforest; fragments; functional traits; nitrate reduction.

INTRODUCTION

Throughout the history, researchers have been tried to understand species' traits in order to assess details about speciation and species interaction to develop conservation and efficient restoration strategies (Cadotte et al. 2011). In the past, traits were mainly used as predictors of organismal performance, but nowadays, due to development in community and ecology studies, trait-based approaches are ranging from the level of organisms to ecosystems (Violle et al. 2007), focusing inclusive in the vegetation responses to global change and others environmental constraints, such as changes in biogeochemical cycles, invasion resistance and stability in the face of disturbance (Pérez-Harguindeguy et al. 2013). The renewed interest in classifying species into groups relating to function rather than to taxonomy has triggered the search for traits that express meaningful differences in ecological behavior among plant species (Garnier et al. 2001). Furthermore, community ecologists are increasingly realizing that a trait-based approach is a better predictor of variability and community productivity than species richness or composition (McGill et al. 2006; Zhang et al. 2017) and they could group species together according to their similarities in function or in response to abiotic conditions (Cadotte et al. 2011).

Besides the increase of functional ecology studies, there is still no clear definition about the “more correct definition” of the terms “trait” and underlying concepts, as “functional traits” (Violle et al. 2007). Violle et al. (2007) highlighted the four criteria to validate an appropriate term proposed by Killingbeck (1986), (1) unambiguous, (2) descriptive, (3) as simple and short as possible, and (4) frequently used to describe the [feature] in question, and they noticed that only criteria 3 was been followed by “trait” term and studies involving this concept.

McGill et al. (2006) defined trait as a “well-defined, measurable property of organisms, usually measured at the individual level and used comparatively across species.” Reinforcing McGill et al. (2006) definition, Violle et al. (2007) suggested the use of traits only at the level of the individual, defining it as “any morphological, physiological or phenological feature measurable at the individual level, from the cell to the whole-organism level, without reference to the environment or any other level of organization.” They also highlighted that at population level, the term “demographic parameters” should be used instead of “trait” and at the community or ecosystem level is preferable the use of “property”. Cadotte et al. (2011) assumed that a trait is “any measurable feature of an individual that potentially affects performance or fitness and can be physical (e.g. plant branching pattern, predator tooth morphology), biochemical (e.g. plant photosynthetic pathway, presence of secondary metabolites), behavioral (e.g. nocturnal vs. diurnal foraging, females cannibalizing males) or temporal or phenological (e.g. flowering time, pelagic duration of larval stage).”

In order to summarize the current concept, plant traits are defined as biological characteristics of plant species related to patterns of establishment, growth and resource allocation, responding to the dominant processes in an ecosystem (Liu & Su 2017) and affect other trophic levels or ecosystem properties (Pérez-Harguindeguy et al. 2013). They are measured at individual level, should vary more between than within species and preferably be measured on continuous scales (McGill et al. 2006). Traits can be of several types (i.e. continuous, categorical, ordinal and binary) and can result from varying degrees of measurement rigour (i.e. hard vs soft traits) (Nock et al. 2016). In most cases, the increased research effort invested into the quantification of functional traits for biodiversity has resulted in an improved understanding of ecological phenomena (Díaz & Cabido 2001; Petchey et al. 2004; Hooper et al. 2005).

According to Cornelissen et al. (2003), nutrient assimilation strategies are considered to be an important functional trait and could be related to plant responses to climate changes, as well as to environmental and biochemical cycles changes and species competition. Nitrogen is addressed in studies of functional attributes in the form of total Nitrogen per unit of dry mass, especially in leaves (Leaf Nitrogen Concentration - LNC - total amounts of N per unit of dry leaf mass, expressed in mg.g^{-1}) (Pérez-Harguindeguy et al. 2013). LNC correlates positively with mass-based photosynthetic rate and tends to represent nutritional quality for consumers in the food chain (WallisDeVries & Bobbink 2017), yet it is

extremely variable among ecosystems (Cornelissen et al. 2003). In addition, nutrient absorption strategies (essentially nitrogen and phosphorus) are significant categorical functional traits that encompass the main acquisition strategies, among them: nitrogen fixers, arbuscular mycorrhiza and ectomycorrhiza (Cornelissen et al. 2003). However, they are a complex trait to be assessed at the individual level and difficult to extrapolate to the ecosystem. Cornelissen et al. (2003) also emphasize the importance of testing new plant traits that could be correlated with others and applied to a wide variety of ecosystems.

Nitrogen availability in the soil can influence the ecosystem composition and dominance, as it could be absorbed by roots in the form of nitrate, ammonium, amino acid and other N-containing substances, expanding species niche coexistence and competition (Liu et al. 2015). The activity of the enzyme nitrate reductase (NRA) is obtained at individual level and can be easily scaled up. This enzyme is considered the bottleneck in nitrate assimilation by plants and could be active at leaves or roots (Andrews 1986; Olsson et al. 2003). Studies are showing that Leaf Nitrate reductase activity (NRA) varies between functional groups (Smirnoff et al. 1984), especially among successional groups (Aidar et al. 2003). Plant growth rate, as well as nutrient recycling, scale along ‘worldwide leaf economics spectrum (LES)’ (Wright et al. 2004) and NRA seems to be more related to fast/ acquisitive strategies. There is a strong correspondence between nitrogen content and photosynthetic capacity (Hikosaka & Osone 2009). However, little is known about the covariance of NRA and other leaf traits.

It is well known that nitrogen is quantitatively the most abundant, limiting and essential nutrient for the plant's growth and life cycle, however the systems are facing an increase of its availability especially due to fertilizers use (Ramos 1996; Stulen et al. 1998). Most of the artificially produced ammonia by Haber-Bosch process (Erisman et al. 2013) is used in agriculture as fertilizer, and about 40% of it is lost to the atmosphere through denitrification, forming nonreactive atmospheric dinitrogen or leached to the water reservoirs (Galloway et al. 2004). Increasing N in the atmosphere influences climate change and promotes greater soil deposition, surface and groundwater pollution and has been identified as one of the main threats to biodiversity and that our knowledge on the “effects of N deposition on ecosystem functioning and biodiversity is still relatively small compared to the magnitude of the problem” as indicated by WallisDeVries & Bobbink (2017).

Thus, understanding the patterns of terrestrial N cycling is essential to predict plant productivity, carbon sequestration of ecosystems, nutrient flow to aquatic ecosystems and losses to the atmosphere (Galloway et al. 2004; 2008). WallisDeVries & Bobbink (2017)

indicates that the great majority of studies that focus in the effects of N deposition on ecosystem is still concentrated in Europe, North America and China. However, research efforts is greatly needed in (sub)tropical parts of the globe where N deposition is increasing, and this would inform us to what extent the effects from N excess differ between temperate and tropical environments.

The manuals of Cornelissen et al. (2003) and Pérez-Harguindeguy et al. (2013) sought to define and standardize some functional attributes of quick and easy measurement, composing a list of minimum traits strongly correlated to the more complex attributes, although the authors emphasize that it shouldn't limit the creativity of researchers, but rather inspire the creation of new attributes, helping to answer new questions or suggest new approaches. Based on the above, the aim of this study is to analyse the NRA as a plant trait and its effect in lumping functional groups. We aim to suggest the inclusion of NRA in trait-based approaches and we believe that it will help to better characterize the species distribution along leaf economic spectrum. Three main research questions would be answered with this study: (1) Nitrate reductase activity is correlated with others important and common traits? (2) This enzyme can help on the characterization of plant functional groups? (3) The use of NRA as a trait will improve our knowledge on functional groups characterization in the Atlantic Forest?

MATERIAL AND METHODS

Study area

The study area was located in the coastal mountain range of the Serra do Mar, in the State of São Paulo, Brazil. We selected two plots (1 ha each) strictly protected at Serra do Mar State Park – Santa Virginia Nucleus, one at old-growth forest, Plot K – named as “O” (Padgurschi et al. 2011) and the other in secondary succession 45 years after short-cut, Plot T – named as “S” (Marchiori et al. 2016). In addition, we had sampled 14 Atlantic forest fragments (0.5 ha each – 0.25ha plot located in the patch border and 0.25ha plot in the inside – 30m far from the border plot). The fragments were mainly located in private properties at São Luís do Paraitinga and Natividade da Serra – São Paulo State, bordered by pastures and cropland, with different past uses, sizes and altitudes (Table 1, Figure 1). This study was part Ecofor Project (Fapesp-NERC/UK) which aimed to understand the the effect of human activities in tropical forests. One way to evaluate this was comparing the border effect on

species diversity and functionality, explaining the proposed methodology of border and inside plots.

The vegetation that composes the Serra do Mar State Park, Santa Virginia Nucleus and its remnants fragments is classified as montane evergreen forest or Montane Ombrophilous Dense Forest (“Floresta Ombrófila Densa Montana”) (Veloso 1991). However, the majority of the fragments is located in a phytogeographical confluence area and predominate Ombrophilous Dense Forest with elements of Semideciduous forest (Aguirre 2008). According to Oliveira Filho and Fontes (2000), the main factor that distinguishes evergreen and deciduous forests is the precipitation variation and the consequent definition of a dry season. According to Köppen (1948), the regional climate can be classified as Cwa, characterized by warm, wet summers and dry winters. The average minimum temperature is 10.6 °C, the maximum of 26.1 °C (Martins 2010) and the average annual rainfall of 2,200 mm with the wettest months being December, January and February (Siegloch et al. 2012). Meteorological data from CIIAGRO (2006) showed that the portion of São Luis do Paraitinga City, where Santa Virginia Nucleus is located, has a decrease in the precipitation level from June to August, whereas the rest of the municipality is much more drier and influence the formation of Semideciduous forest. The soils are characterized as Red-Yellow Latosol and Haplic Cambisol (IBGE 2001).

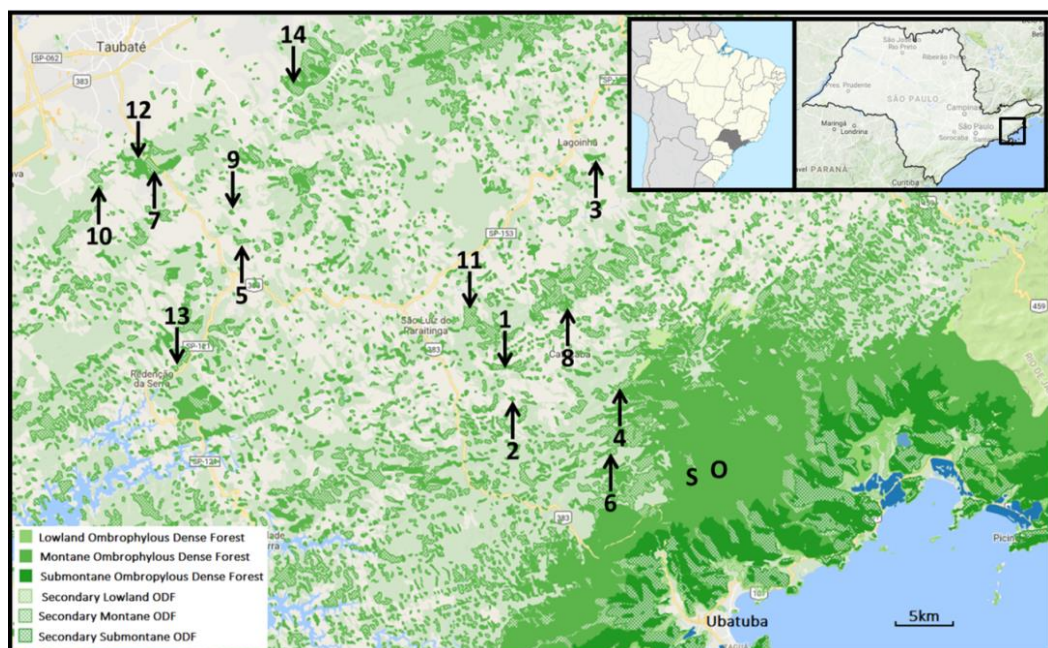

Figure 1. ECOFOR sites (BIOTA-FAPESP/NERC-UK Project). O – Old growth forests; S – Secondary forests; and 1 to 14 – Fragments of modified forests. São Paulo, Brazil

Table 1. Description of sites, characterization and specific locations. Fragments – F1 to F14 – are located at São Luís do Paraitinga and Natividade da Serra; Plots S and O are part of Biota Functional Gradient Project and located at Serra do Mar State Park – Santa Virginia Nucleus, São Luís do Paraitinga – São Paulo State – Brazil. Nspp 70% BA – number of species included in the sample (basal area of the species included in 70% of the site total basal area); Alt (m.a.s.l) – altitude – mean sea level (m).

Site	Nspp 70%BA	Alt (m.a.s.l.)	Area (ha)	Plot (ha)	Latitude	Longitude
F1	5	920	94.6	0.5	23°15'08.62" S	45°15'03.98" W
F2	22	920	12.2	0.5	23°16'30.98" S	45°14'28.20" W
F3	13	880	53.4	0.5	23°05'56.84" S	45°10'53.70" W
F4	5	1150	30.3	0.5	23°16'50.12" S	45°10'24.38" W
F5	8	800	24.2	0.5	23°09'39.34" S	45°27'23.85" W
F6	19	980	30.3	0.5	23°19'27.25" S	45°11'25.40" W
F7	10	700	9.8	0.5	23°05'40.43" S	45°32'27.98" W
F8	14	980	19.9	0.5	23°12'25.03" S	45°11'47.15" W
F9	13	720	15.5	0.5	23°08'26.59" S	45°28'02.13" W
F10	14	700	98.1	0.5	23°06'51.77" S	45°34'42.37" W
F11	20	820	85.1	0.5	23°12'40.56" S	45°16'45.14" W
F12	16	760	247.6	0.5	23°06'19.42" S	45°32'37.15" W
F13	12	800	83.4	0.5	23°14'59.93" S	45°30'32.02" W
F14	11	700	10.6	0.5	23°03'29.38" S	45°25'13.83" W
S	14	970	forest	1	23°19'50.60" S	45°05'67.80" W
O	23	1020	forest	1	23°19'31.00" S	45°04'07.00" W
total	219			9		

Vegetation sampling

In each plot we selected species that represent 70% of the total basal area and sampled three mature individuals (or two when wasn't available three individuals) and completely exposed to light (except for understory individuals). According to Cornelissen et al. (2003), species with high biomass and basal area are considered dominants in the community and their functionality could represent the community and ecosystems if it is scaled up. For each plot the number of species was specific, based on species abundance, richness and dominance. A total of 219 species were sampled in the 16 forest sites, representing a total of 112 different species (Annex 1).

We selected five plant traits that have been identified as suitable to predict species responses to environmental change and effects on ecosystem processes in plant communities, and were easy-to-measure ("soft traits") (Cornelissen et al. 2003). Three traits were related to

structure, plant growth and water use (LMA: leaf dry mass per unit area- $1/\text{SLA}$; LDMC: Leaf Dry Matter Content and WD: wood density), one trait was related carbon assimilation (Asat: light saturated net photosynthetic rate, area basis) and one related to nutrient/ nitrogen assimilation (NRA: nitrate reductase activity enzyme). The Leaf dry matter content (LDMC; dry leaf mass/water-saturated fresh leaf mass - $\text{g}\cdot\text{g}^{-1}$) and leaf dry mass per unit area (LMA; leaf dry mass/ leaf area- $\text{g}\cdot\text{m}^{-2}$) are considered key traits with well-established sampling protocols and with low error variance, details about the procedures could be found in Wilson et al. (1999), Niinemets (1999), Garnier et al. (2001) and Cornelissen et al. (2003).

Leaf gas exchange was measured in three mature and completely expanded leaves of three individuals per species (total of nine measurements). Soon after the field collection, detached branches were immediately re-cut under water to restore hydraulic connectivity and kept in shade to have their photosynthesis measured in the next day (Rowland et al. 2017, 2015). All gas exchange measurements were made between 08:00 h and 12:00 h, instantaneous measurements of light-saturated photosynthesis (Asat) ($1,500 \mu\text{mol m}^{-2}\text{s}^{-1}$) and others parameters related were made using a Li-Cor 6400 portable photosynthesis system (Li-Cor Inc., Lincoln, NE, USA). The procedure details could be found in Rowland et al. (2017).

Wood density (WD) is a stem trait very important to the ecology of woody plants as it reflects carbon allocation to structural support, correlating negatively with growth rate and reflecting conservative strategies (Preston et al. 2006; Díaz et al. 2016). The samples were taken from the same individuals used for other traits. The pith and bark were removed, and volume was measured by water displacement (Rosado et al. 2016). Sample mass was determined after drying for at least 2 d at 70°C and we obtained values of oven dry mass per fresh volume ($\text{g}\cdot\text{cm}^{-3}$) (Cornelissen et al. 2003).

The activity of the Leaf NR enzyme was determined *in vivo* on the basis of the procedure proposed by Stewart et al. (1986). Samples (0.10 gFW) of fully expanded leaves were sliced into small fragments, vacuum infiltrated with 2.5 ml of assay solution (0.05 M KH_2PO_4 , pH 7.5, 0.1 M KNO_3 and 1.5% propanol) and then incubated 60 min in darkness at 30°C . The nitrite was colorimetrically determined at 540 nm through a spectrometer after azocoupling with sulfanilic acid (1ml [1% (w/v) in 1.0 N HCl]) and naphthylethylenediamide dihydrochloride - NED (1ml [0.05% (w/v)]). All enzyme assays were carried out on at least duplicate samples (Stewart et al. 1986; Aidar et al. 2003).

Statistical analysis

After checking frequency distributions for normality and variance heterogeneity, species-specific leaf trait values were calculated using arithmetic means and it was necessary to present NRA, LMA as Box-Cox transformed (power transform) and Asat(a) as log10-transformed prior to statistical analysis. We used both univariate and multivariate statistics to compare the differences among plant species, families and functional groups. We used Pearson correlations to examine inter-trait correlations, all significant at a P level of 0.05. To examine the generality of the correlation patterns between traits and to visualize the relationships between our functional groups, fragments or families in a multivariate context, we performed a principal components analysis (PCA) and Cluster analysis with Euclidian distance and UPGMA agglomeration method with the measured traits. After Cluster analyses, we cluster species in functional groups and proceed a Linear Discriminant Analysis (LDA) with this groups, followed by a MANOVA test. All statistical analyses were carried out using R (R Development Core Team, 2011), FITOPAC 2.1.2 (Sheperd 2010) and PAST 3 (Hammer et al. 2001).

RESULTS

TRAITS CORRELATIONS

We measured traits on each of 219 tree species in 16 sites (N = 3 or 2 for each species) resulting in 526 individuals sampled. All samples are pooled together in species level, disregarding the site, obtaining a total of 112 unique species (aneex 1). In our analyses were excluded Arecaceae species (*Euterpe edulis* or *Syagrus romanzoffiana*), because we couldn't measure their wood density. Most of traits measured were correlated in the LES dimension (acquisitive – conservative spectrum): Nitrate reductase activity was significantly correlated to LMA (-0.267%), WD (-0.211%) and Asat(a) (0.241%), as were LDMC to LMA (0.389%), WD (0.505%) and Asat(a) (-0.318%) (Table 3).

Table 2. Functional traits sampled, their respective units, transformation to normality and functional strategies. LMA= leaf mass area, LDMC= leaf dry matter content, WD= wood density, Asat (a) = photosynthetic rate saturated in light and CO₂ by unit of leaf area, NRA= Leaf nitrate reductase activity.

Plant traits	Abbreviation	Unit	Transformation	Functional Strategy	References
Leaf dry mass per unit area	LMA (1/SLA)	g m ⁻²	Box-Cox	Investments in leaf construction (lignine and other secondary compounds) and defences' and long leaf lifespan	Niinemets 2001; Poorter et al. 2009
Leaf Dry Matter Content	LDMC	g g ⁻¹		Level of assimilative compounds and transfer conductance to CO ₂ , construction costs, nutrient retention, tolerance against water limitations and mechanical and herbivore damage	Niinemets 2001; Garnier et al. 2004; Poorter & Markesteijn 2008; Lohbeck et al. 2013
Wood density	WD	g cm ⁻³		Construction costs, growth rate, stem vulnerability, mortality rate, resistance against cavitation, drought tolerance	Poorter et al. 2008; Chave et al. 2009; Poorter et al. 2010; Lohbeck et al. 2013
Light-saturated photosynthetic capacity (at ambient CO ₂) per unit leaf area	Asata	μmolCO ₂ m ⁻² s ⁻¹	Log	Acquisition of CO ₂	Cornelissen et al. 2003; Reich 2014
Nitrate reductase activity	NRA	pkat.FW-1	Box-Cox	Inorganic Nitrogen assimilation	Stewart et al. 1986; Aidar et al. 2003

Table 3. Pearson's correlation between the pairs of variables analyzed, in the upper triangle are the values of the probability of the relations being at random and in the lower triangle the values of the Pearson correlation. LMA= leaf dry mass per unit (g.m²), LDMC = leaf dry matter content (g.g⁻¹), Wd = wood density (g.cm⁻³), NRA = activity of the enzyme nitrate reductase in the leaf (pkat FW⁻¹) and Asat(a) = photosynthetic rate by unit of leaf area (μmolCO₂m⁻²s⁻¹). Gray colors indicate significant correlation.

	LMA	LDMC	WD	NRA	Asat(a)
LMA		2.840 E-09	0.004	0.005	0.729
LDMC	0.389		2.103 E-08	0.136	0.0007
WD	0.274	0.505		0.027	5.051 E-07
NRA	-0.267	-0.143	-0.211		0.011
Asat(a)	0.033	-0.318	-0.459	0.241	

PRINCIPAL COMPONENT ANALYSIS

A multivariate analysis of rainforest plant species ordinated in trait space identified three major ordination axes that explained 82.4% of the data variation. The first PCA axis (43.1%) represented a gradient of acquisitive - conservative strategies being mainly guided by WD (54.6%) and LDMC (52.2%), which are related to resource investment in

wood structure and leaf (leaf density), respectively. LDMC also is normally related to the leaf water storage capacity and low values are normally associated to higher productivity (Cornelissen et al. 2003). The second axis (21.3%) is influenced by high LMA (72.1%) and Asat(a) (63.6%) and represent carbon acquisition, leaf investment and indicate two different functional groups, one with more conservative strategies and other with more acquisitive. The third axis (18.0%) was defined primarily by leaf nitrate assimilation (NRA=86.8%) (Figure 2).

To reinforce the importance of leaf nitrate assimilation on functional traits analysis, we performed an analysis with the same dataset without the NRA. With this new approach, we could explain 76.7% of species variance and the first two axes was explained by LDMC/ WD (58.0%) and LMA (73%) and Asat(a) (63%), respectively. We could notice that, without NRA, traits related to structure and conservative strategies predominate in the functional species distribution. We also tried to rearrange the dataset, taking off Asat(a) and including NRA. In this approach, NRA was the main trait influencing the second axis (84.2%), keeping LDMC (56.6%) and WD (54.3%) as the major guiders in the first principal component.

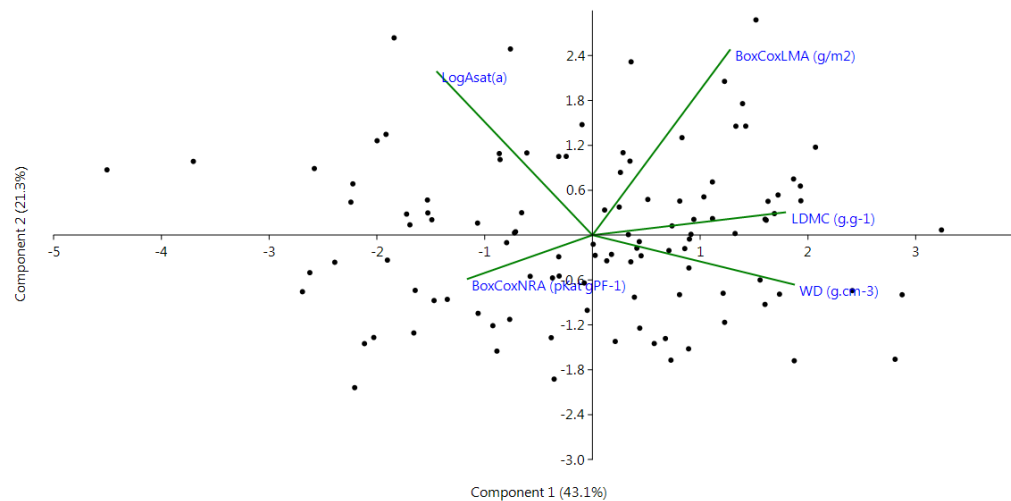

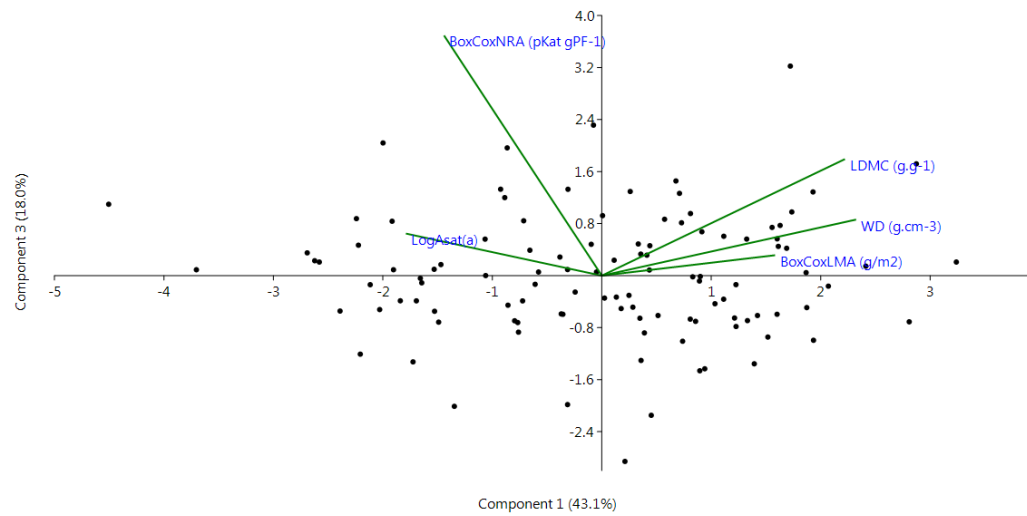

Figure 2. Results of the Principal Component Analyses applied to functional traits of tree species from Atlantic forest fragments. A. First and second axis of the PCA. B. First and Third axis of the PCA. LMA= leaf dry mass per unit (g.m^2), LDMC = leaf dry matter content (g.g^{-1}), WD = wood density (g.cm^{-3}), NRA = activity of the enzyme nitrate reductase in the leaf (pkat FW^{-1}) and Asat(a) = photosynthetic rate by unit of leaf area ($\mu\text{molCO}_2\text{m}^{-2}\text{s}^{-1}$).

USING NEW TRAITS TO JOIN SPECIES IN DIFFERENT GROUPS

Principal Component Analysis of leaf traits lumped by families (PC1=43.1% and PC2=21.3%), highlighted which are the main traits and strategies considering Leaf economic spectrum for families (Figure 3). Urticaceae, represented by *Cecropia* spp., is in the extreme of acquisitive strategies, with high photosynthetic and nitrate reductase activity. In the other extreme, showing conservative strategies, we find Lauraceae with high LDMC and WD and Melastomataceae with high LMA. Many Fabaceae species fix nitrogen from the atmosphere and they seem to be more related to the acquisitive axis (Figure 3).

Usually, species are defined by their ability to germinate and survive in light conditions. In this way, species can be defined as Pioneer (P) when they are light demand or Non-pioneer (NP) if they are more successful without excessive light during germination. This last group include Late secondary (LS), Early secondary (ES) and under canopy species (UC) (Gandolfi et al. 1995). We performed a PCA with our functional traits and lumped species by their successional groups, and found 64.4% of the variation, confirming that species defined as Pioneer have acquisitive strategies (higher Asat(a) and NRA) and in Non-

pioneer species a more conservative strategy tended to be associated with a construction and “defence”, related to conservative traits (LMA, LDMC and WD) (Figure 4).

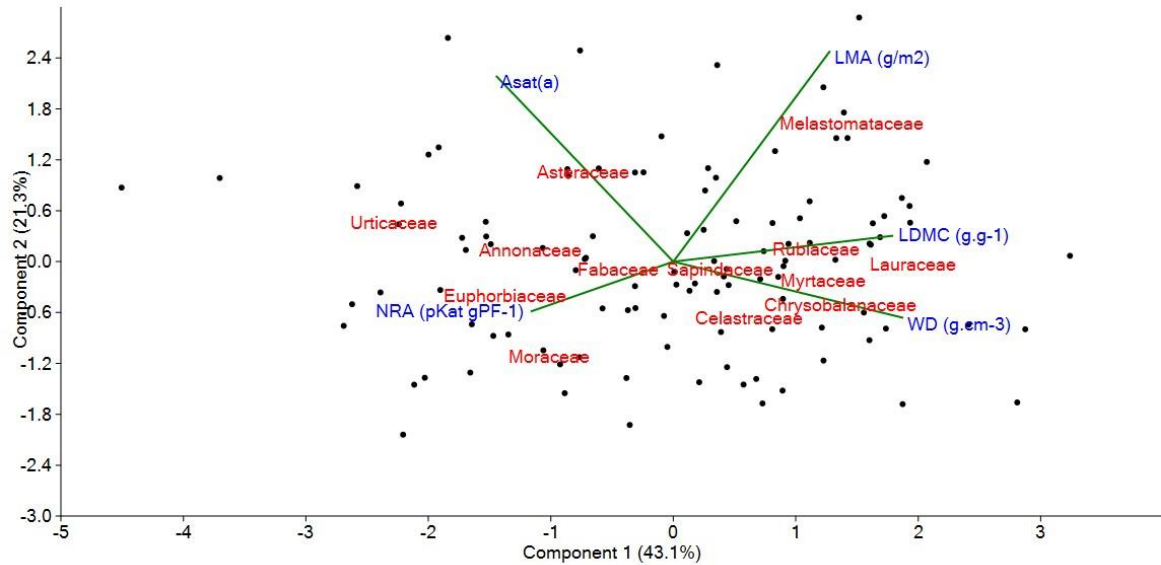

Figure 3. Results of the Principal Component Analyses applied to families from Atlantic forest tree species (PC1x PC2). LMA= leaf dry mass per unit (g.m^2), LDMC = leaf dry matter content (g.g^{-1}), Wd = wood density (g.cm^{-3}), NRA = activity of the enzyme nitrate reductase in the leaf (pkat FW^{-1}) and Asat(a) = photosynthetic rate by unit of leaf area ($\mu\text{molCO}_2\text{m}^{-2}\text{s}^{-1}$).

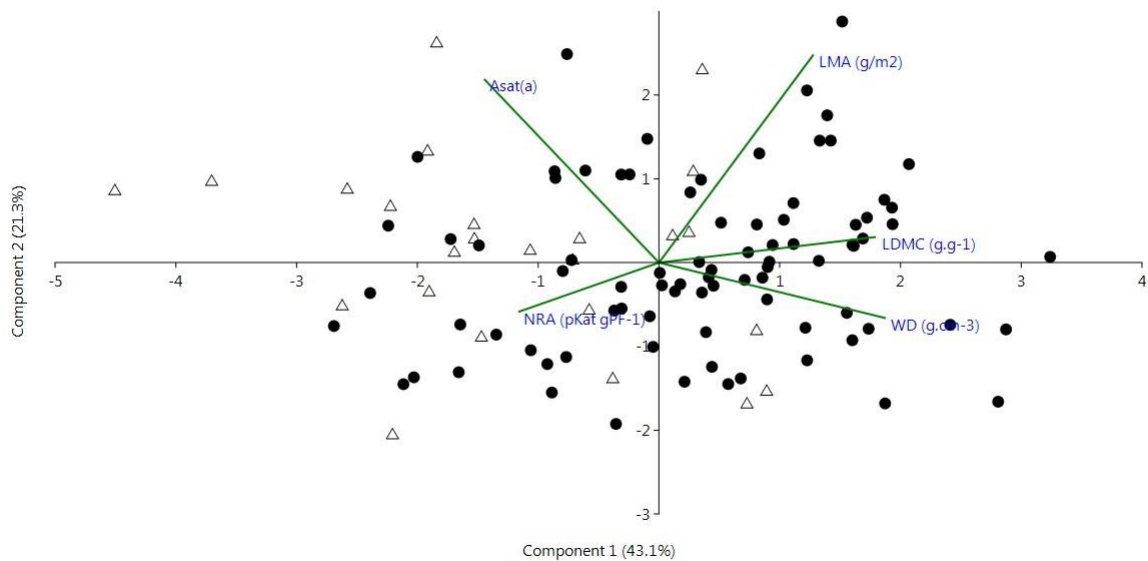

Figure 4. Principal Component Analysis grouped by successional groups. Species represented by (Δ) are defined as Pioneer (P) and those represented by (\bullet) are Non-pioneer species.

Finally, we grouped our species by their functionality and we found that NRA was the most important trait to distinguish functional groups. We based our Discriminant Analysis (Figure 6) on Cluster analysis (Figure 5), which joined all species by their similarities considering our five defined traits, resulting in separation of four functional groups. After this, we evaluated the response to traits of each species, defined the group response in four quartiles and classified as Low (*), Medium low (**), Medium high (***) and High (****) (Table 4). MANOVA test indicates that all functional groups are statistically different (Wilks's lambda=0.124; df1=15; df2=279.2; F=21.06; p<0,001). These analyses demonstrated two extremes in leaf economic spectrum: group Yellow composed by 14 species with acquisitive strategies and group Purple with 13 species and conservative strategies. Although there was a clear trend of separation between the extremes considering leaf economy spectrum in all traits, for our data set, the clearest was by the enzyme nitrate reductase. In figure 6 is possible to notice that species with high activity of nitrate reductase enzyme were in one extreme and those with low activity were in the other, demonstrating a very clear behavior and importance to be considered in Leaf Economic Spectrum and leaf traits approach.

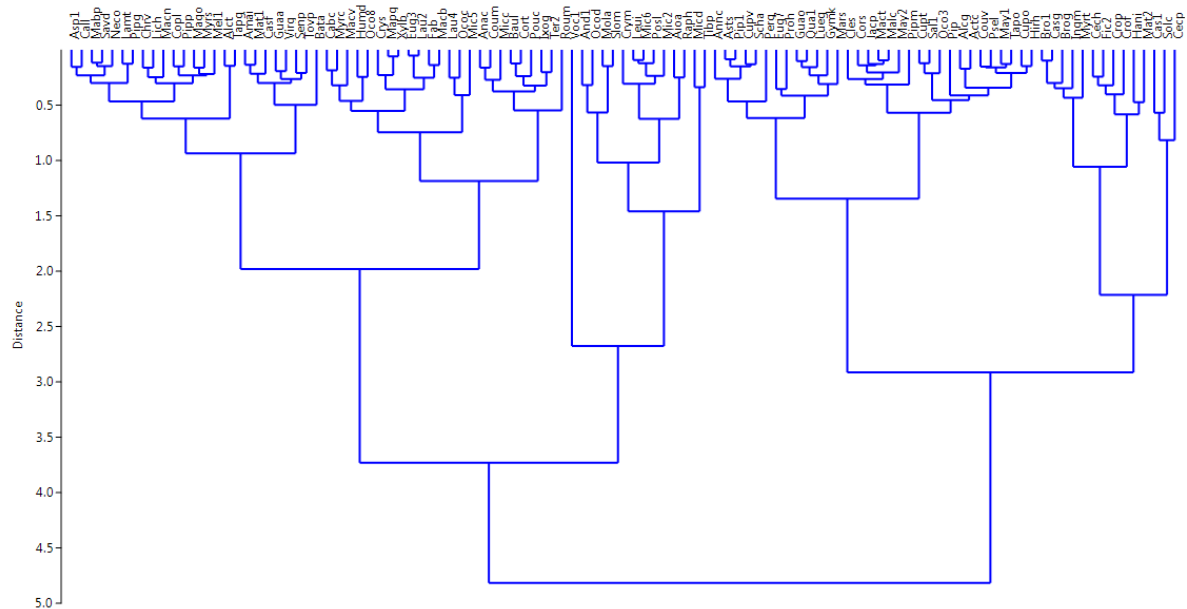



Figure 5. Cluster analysis of Atlantic forest fragments grouped by their response to four leaf traits (LMA, LMDC, WD NRA, Asat(a)), Euclidian distance and UPGMA (ccc=0.666).

Table 4. Leaf traits response in each functional group. LMA= leaf dry mass per unit ($\text{g}\cdot\text{m}^2$), LDMC = leaf dry matter content ($\text{g}\cdot\text{g}^{-1}$), WD = wood density ($\text{g}\cdot\text{cm}^{-3}$), NRA = activity of the enzyme nitrate reductase in the leaf ($\text{pkat}\ \text{FW}^{-1}$) and Asat(a) = photosynthetic rate by unit of leaf area ($\mu\text{molCO}_2\text{m}^{-2}\text{s}^{-1}$). Low (*), Medium Low (**), Medium High (***) and High (****) represent the traits values of the species that composes each group. All groups are statistically different.

GROUP	COLOR	#SPP	LMA	LDMC	WD	NRA	ASAT a	
I	Yellow	14	**	*	*	****	***	FAST
II	Red	32	**	**	**	***	**	
III	Blue	49	***	***	**	**	**	
IV	Green	13	***	***	***	*	**	

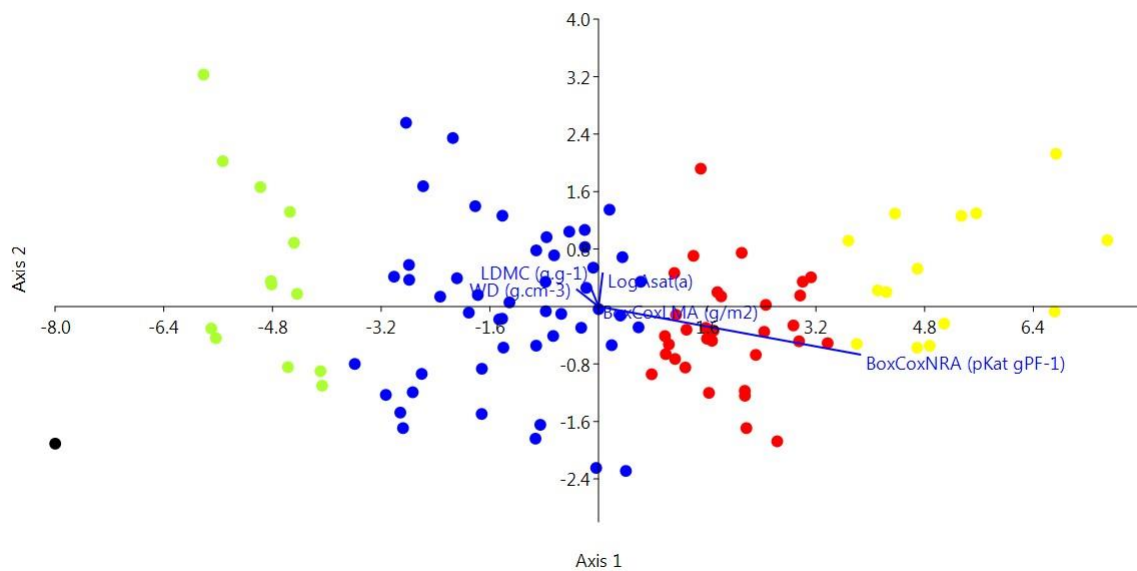

Figure 6. Discriminant analysis (LDA) and functional groups highly influenced by nitrate reductase activity enzyme in axis 1 (97.83%). Group I (Yellow), Group II (Red), Group III (Blue) and Group IV (Green) – the group of each species sampled in the study could be found in annex 1.

DISCUSSION

In this article, we present a comprehensive comparison of physiological processes and leaf traits in tree species under tropical field conditions. Our study of 112 plant species represents the first work including NRA as an important leaf trait and yielded novel insights into physiological differences among functional groups, specially related to plant nitrogen assimilation.

Cornelissen et al. (2003) point out that classifying species solely by their taxonomy is limiting to answer ecosystem, landscape and biome patterns and processes, especially when it comes to issues associated with climate change, atmospheric chemistry, and land use modification. According to these authors, the use of plant traits to lump species is a promising tool for a better understanding of the functionality and processes that modulate the species and has similar responses or roles in ecosystems or biomes, defining Plant functional groups types (PPTs) (Apgaua et al. 2017). Lavorel et al. (1997) defined PPTs as non-phylogenetic groupings of species which perform similarly in an ecosystem based on a set of common biological attributes (Keddy 1992b; McGill et al. 2006).

We observed well known leaf traits correlations and in accordance to the literature. We found a marginally correlation between LMA and LDMC (Table 2), as well as Wright & Cannon (2001). However, these two traits had some differences in the correlation, while LMA wasn't correlated to Asat(a), LDMC had a no significant correlation with NRA.

Leaf dry mass per area (LMA) is generally positively related to both density (D) and thickness (T). Niinemets (2001) suggest that leaf thickness scales positively with irradiance and leaf density with soil water limitations. LMA is a primary plant functional trait that represents the cost of constructing a leaf, their lifespan and the reduction to the susceptible to herbivory and to other physical hazards (Griffith et al. 2016; Wright & Cannon 2001). This trait is generally negatively correlated to photosynthetic capacity (A), nitrogen content per mass and positively to leaf lifespan (Wright et al. 2004). Another important trait considered in this study was Leaf dry matter content (LDMC, the ratio of leaf dry mass to fresh mass), which reflect a fundamental trade-off in plant functioning between a rapid production of biomass (low LDMC species) and an efficient conservation of nutrients (high LDMC species) (Poorter & Garnier 1999). LDMC is considered to be a better predictor of plant performance along resource gradients than LMA, as it reflects leaf construction and resources allocation (Shipley et al. 2006a). However, Nock et al. (2016) strongly suggest the use of LMA, since it could be considered both an effect trait (leaves with more mass per unit

area decompose more slowly and affects nutrient cycling) and response trait (plants tend to increase productivity under dry conditions by improving water use efficiency, reducing their specific leaf area and increasing the total leaf area (more leaves) to enhance photosynthesis (Wright et al. 2002; Zhang et al. 2017).

Wright & Cannon (2001) highlighted that many studies across continents and growth forms are suggesting that the major spectrum of variation between species segregates those species with long-lived leaves, including high LMA and slow net photosynthetic rate (mass basis) from species short-lived leaves (or acquisitive strategies), low LMA and fast photosynthetic rate. However, we didn't find a positive correlation between LMA and Asat (a), and this could be due area-based photosynthesis instead mass-based (Souza et al. 2015). This is a common situation observed on the literature and there is still a wide discussion about the significance on the weaker associations between foliar properties when expressed on an area-basis (Reich et al. 1998; Wright et al. 2004; Shipley et al. 2006; Lloyd et al. 2013; Keenan & Niinemets 2016).

The correlation of wood density with all leaf trait was coherent with several other studies. Leaf and wood traits should be closely coupled along a spectrum of plant strategies from fast-growing, resource-acquiring species with low investment in leaf and wood tissues to slow-growing, resource-conserving species with high investment (Santiago et al. 2004, Chave et al. 2009). Generally, species with dense wood also have relatively small leaves (Malhado et al. 2009, Baraloto et al. 2010) and this has been interpreted as an adaptation to water limitation and higher water use efficiency (Wright et al. 2006). High LMA is sometimes associated with high wood density (Richardson et al. 2013), but nonsignificant relationships have also been reported (Wright et al. 2007; Baltzer et al. 2009; Zhang & Cao 2009). Correlations between wood density and the component traits underpinning LMA (i.e., LDMC, leaf size, leaf thickness and leaf density) have received relatively little attention but indicate that species with a high wood density also have high LDMC (Kitajima et al. 2010).

Species at the nutrient-conserving end of the spectrum typically have high LMA, low leaf nutrient concentrations, and low photosynthetic capacity (Reich 2014; Reich et al. 1997); species at the other end of the spectrum typically have the opposite characteristics, low tissue density and cell wall content; high rates of carbon and nutrient uptake; and short-lived leaves (Lavorel et al. 2002). However, the knowledge about the correlations of NRA and others leaf traits were still unknown.

Studies have been assuming that plant productivity is largely determined by the interaction between carbon and nitrogen metabolism. These two processes are closely interconnected, since the energy required for nitrogen assimilation derives directly and indirectly from photosynthesis. Tang et al. (2012) used the NRA to test the effects of enrichment of N and verified that the *in vivo* NRA varies according to light intensity, since nitrate reductase competes for energy with carbon fixation under shade conditions. According to Melzer & O'Leary (1987), amino acid synthesis depends on the availability of the carbon skeleton provided by photosynthesis, because the triose phosphate obtained from photosynthetic reaction could be used in the synthesis of carbohydrates and ketoacids. Then, 2-oxoglutarate produced in the cytosol, is transported to the chloroplasts and acts as an ammonium acceptor during amino acid synthesis (Nunes-Nesi et al. 2010).

Nitrate is reduced to nitrite in the cytosol by the nitrate reductase enzyme (NR) and this reduction can occur in both roots and leaves. Nitrite is reduced to ammonium and then to amino acids in roots and leaves by a series of enzyme-mediated reactions, the glutamate synthase or GS-GOGAT cycle (Beever & Hageman 1969; Tang et al. 2012). By assessing NRA in the tissues, it is possible to get an indirect evidence of the occurrence of nitrification in forest soils. It has been established that light, drought, mineral nutrition, hormonal treatment, plant age and genetic composition all influence the capacity for nitrate reduction (Beever & Hageman 1969; Adams & Attiwill 1982). Nitrate reductase activity (NRA) analysis can thus be used as a method for measuring plant available soil NO_3 . This method has a number of advantages for monitoring soil NO_3 : it is rapid, inexpensive, can be easily performed at lab field condition (Aidar et al. 2003), does not disturb the soil, and gives a direct indication of plant available NO_3 .

In the Principal Component Analysis (Figure 2; Table 4), we noticed that NRA was a good trait to distinguish functional groups, being the main trait guiding the third axis. The traits that compose the first axis aren't independent, they are highly correlated, and we could affirm that the first axis is the acquisitive-conservative spectrum driven by resources investment in leaf (LMA) and wood (WD). The second axis, was represented by two independent variables (Asat(a) and LMA) and NRA was the main driver in the third axis. In every community, there is a continuum of leaf nitrate reductase activity, from low to high, related to increasing Leaf Specific Area ($1/\text{LMA}$) (Stewart et al. 1990). Because leaves with more mass per unit area decompose more slowly, nutrient cycling in mixtures of species with high LMA will be slower compared to mixtures with low LMA, relating decomposition and

nutrient cycling. The leaf trait LMA acts as an effect trait – it affects nutrient cycling (Nock et al. 2016).

We found a considerable taxonomic patterning in leaf traits (Figures 3 and 4). Species and their corresponding family considered pioneer were mainly found in acquisitive and fast-growing strategies axis of the PCA, and those classified as non-pioneer were found in more conservative axis. Species from Urticaceae, Asteraceae, Annonaceae, Moraceae and Euphorbiaceae had higher photosynthetic and NRA, with greater capacity to uptake carbon inorganic nitrogen and probably total nitrogen. On the other extreme, representing conservative strategies, we found Lauraceae, Myrtaceae, Celastraceae and Chrysobalanaceae with high WD and Sapindaceae, Rubiaceae and Melastomataceae with higher LMA and LDMC. According to Stewart et al. (1990), some species of monocotyledon and small-leaved from Asteraceae and Fabaceae families, which possess higher proportions of structural tissue per unit area of leaf, showed lower levels of nitrate reductase activity, in opposition to what we saw in this study. Gebauer et al. (1988) found high NRA in Urticaceae, Lamiaceae and Polygonaceae families in Central Europe and refers that these families are usually fast growing plants. These authors also indicated that Fabaceae had much higher contents of organic nitrogen than the means of all others species sampled in the same habitats, due to the symbiosis with N₂-fixing bacteria and/or the well-known nitrogen-demanding lifestyle (Mckey 1994).

Disturbance in forests lead to quickly soil nitrate production and availability, which favours the establishment of pioneer species with high leaves and root NRA (Aidar et al. 2003). Typically, plants associated with nutrient rich sites, usually the case of disturbed sites, tend to have high NO₃ content in the soil and induce nitrate reductase enzyme in plant species (Gebauer et al. 1988; Srivastava 1980). As closed forest communities regenerate, these pioneer species can persist for many years in competition with mature-phase species (with low nitrate reductase activity) (Stewart et al. 1990; Aidar et al. 2003). It is possible to notice that the functionality of many species were coherent to their successional group classification, Pioneer species had higher NRA and Asat, while Non-pioneer were represented by increased values of LMA, LDMC and WD (Figure 4).

NRA was the main trait responsible for the distinction of plant functional traits of species at Atlantic Forest sites. Besides other traits also had a gradient of response, NRA had the clearest distinction and, we propose that it should be added in plant traits approaches at tropical systems (Figure 6, Table 4). Gebauer et al. (1988) concluded that Nitrate content,

NRA and content of organic N of the examined plants depend partly on species, but largely on the ecological behavior (sites preference with higher or lower N supply) and this reinforces the importance of NRA as a trait with good predictive power for identifying tree functional characteristics and strategies.

It is conceivable that there would be greater complementarity (or competition) belowground than aboveground for limiting resources (water and nutrients) (Siebenkas & Roscher, 2016). Thus, to a deep understanding about plants relations, it is also important to consider belowground biomass and functionality to explain the variation in community productivity. We should strengthen the research about plant root functional traits and community belowground and aboveground productivity (Zhang et al. 2017).

CONCLUSION

We propose that NRA should be added in leaf traits studies, especially because it is a soft trait, easily field measured and has high potential to highlight acquisitive species or strategies (pioneer or early successional). This view of species as an assemblage of traits is reshaping how ecologists measure diversity, assess coexistence and restore habitats and surely it will provide better conservation and restoration plans and management. Two extremes of functional strategies could be distinguished from the range of trait variation that defines the leaf economics spectrum. At one extreme, species with a conservative resource-use strategy, showing high values of LMA, LDMC, high-density wood tissues and low NRA that allow them to increase competitive abilities in late and nutrient-poor environments. In the opposite extreme, species with a predominant resource-acquisition strategy have attributes associated to rapid resource capture and high relative growth rate.

ACKNOWLEDGEMENTS

This work is the product of EcoFor Project founded by Biota-FAPESP and UK Natural Environment Research Council (NERC) (Fapesp 2012/51872-5) and National Council for Scientific and Technological Development (CNPq and Capes) funding to N.M.M. We also thank Renato Belinello (UNICAMP, Brazil), Santa Virginia Nucleus Administration and owners of forest fragments sampled for providing valuable support and advice. Thanks also to Wagner Toledo for assistance in the field.

AUTHOR CONTRIBUTIONS

N.M.M. and M.P.M.A. planned and design the nitrate reductase activity analysis, M.A.M. and M.P.M.A planned and designed the structural and photosynthesis traits analysis, N.M.M., D.M., S.L.R., M.A.M., F.F. L.H. and H.B.B. conducted fieldwork and analysed the data. N.M.M. and M.P.M.A. wrote the manuscript, with contributions from all authors.

Annex 1. List of species and families found in 14 sites with different stages of succession and past use at Atlantic Forest, Southernest of São Paulo, Brazil. COD – Species code (first 3 letters from genus and 1 letter from species name), FUNC – functional group (Table 4), SUC – successional group (P: pionner, NP: non-pionner), F1-F14: fragments at São Luis do Paraitinga and surroundings, O and S: plots of old-growth and secondary forest at Conservation Unit – Serra do Mar State Park.

SPECIES	FAMILY	COD	FUNC	SUC	F1	F2	F3	F4	F5	F6	F7	F8	F9	F10	F11	F12	F13	F14	O	S
<i>Actinostemon concolor</i> (Spreng.) Müll.Arg.	Euphorbiaceae	Actc	red	NP	X															
<i>Aiouea acarodomatifera</i> Kosterm.	Lauraceae	Aioa	green	NP																X
<i>Alchornea glandulosa</i> Poit. & Baill.	Euphorbiaceae	Alcg	red	P																X
<i>Alchornea triplinervia</i> (Spreng.) Müll.Arg.	Euphorbiaceae	Alct	blue	P																X
<i>Amaioua intermedia</i> Mart. ex Schult. & Schult.f.	Rubiaceae	Amai	blue	NP			X				X									X
<i>Anadenanthera colubrina</i> (Vell.) Brenan	Fabaceae	Anac	blue	NP	X				X			X	X	X		X	X			
<i>Andira sp.</i> Lam.	Fabaceae	And1	green	NP			X				X				X					
<i>Annona cacans</i> Warm.	Annonaceae	Annc	red	P										X						
<i>Aspidosperma sp. 1</i> Mart. & Zucc.	Apocynaceae	Asp1	blue	NP						X		X	X		X					
<i>Asteraceae sp. 2</i>	Asteraceae	Asts	red	P													X			
<i>Bathysa australis</i> (A.St.- Hil.) K.Schum.	Rubiaceae	Bata	blue	NP																X
<i>Bauhinia longifolia</i> (Bong.) Steud	Fabaceae	Baul	blue	P								X								
<i>Brosimum guianense</i> (Aubl.)	Moraceae	Brog	yellow	NP					X				X			X				

SPECIES	FAMILY	COD	FUNC	SUC	F1	F2	F3	F4	F5	F6	F7	F8	F9	F10	F11	F12	F13	F14	O	S
<i>Leucochloron incuriale</i> (Vell.) Barneby & J.W. Grimes	Fabaceae	Leui	green	NP								X	X							
<i>Licania hoehnei</i> Pilg.	Chrysobalanaceae	Lich	blue	NP															X	X
<i>Luehea candicans</i> Mart. & Zucc.	Malvaceae	Luec	red	P																
<i>Luehea grandiflora</i> Mart. & Zucc.	Malvaceae	Lueg	red	P		X						X		X						
<i>Mabea piriri</i> Aubl.	Euphorbiaceae	Mabp	blue	P					X				X	X					X	
<i>Machaerium brasiliense</i> Vogel	Fabaceae	Macb	blue	NP																X
<i>Machaerium nyctitans</i> (Vell.) Benth.	Fabaceae	Macn	blue	NP		X						X		X	X					
<i>Machaerium villosum</i> Vogel	Fabaceae	Macv	blue	NP								X								
<i>Maclura tinctoria</i> (L.) D.Don ex Steud.	Moraceae	Mact	red	NP										X						
<i>Magnolia ovata</i> (A.St.-Hil.) Spreng.	Magnoliaceae	Mago	blue	NP						X										
<i>Malouetia cestroides</i> (Nees ex Mart.) Müll.Arg.	Apocynaceae	Malc	red	NP													X			
<i>Maprounea guianensis</i> Aubl.	Euphorbiaceae	Mapg	blue	NP		X														
<i>Marlierea silvatica</i> (Gardner) Kiaersk.	Myrtaceae	Mars	red	St																X
<i>Matayba sp. 1</i> Aubl.	Sapindaceae	Mat1	blue	NP						X										
<i>Matayba sp. 2</i> Aubl.	Sapindaceae	Mat2	yellow	NP			X													
<i>Maytenus sp. 1</i> Molina	Celastraceae	May1	red	NP		X						X								
<i>Maytenus sp. 2</i> Molina	Celastraceae	May2	red	NP												X				
<i>Meliaceae sp. 1</i>	Meliaceae	Mel1	blue	NP						X										
<i>Miconia cabussu</i> Hoehne	Melastomataceae	Micc	blue	NP														X	X	X

SPECIES	FAMILY	COD	FUNC	SUC	F1	F2	F3	F4	F5	F6	F7	F8	F9	F10	F11	F12	F13	F14	O	S
<i>Virola cf. gardneri</i> (A.DC.) Warb.	Myristicaceae	Virg	blue	NP												X				
<i>Vochysia sp. 1</i> A.St.-Hil.	Vochysiaceae	Voc1	black	NP		X														
<i>Xylopia brasiliensis</i> Spreng.	Annonaceae	Xylb	blue	NP		X							X			X	X	X		

CHAPTER 3

Are nitrogen use strategies functional to assess tropical forest succession?

MARCHIORI, N.M. ^{A,D}; MARABESI, M.A. ^A; FERNANDES, F.^B; BRUNO, H.B. ^B; HAMACHI, L. ^B; MARINHO, D. ^B; ALMEIDA, V. ^B; CARDINELLI, L. ^A; RIBEIRO, S.L. ^C; AIDAR, M.P.M. ^B

^A Department of Plant Biology, Institute of Biology. P.O.Box: 6109, University of Campinas – UNICAMP - 13083-970, Campinas, SP, Brazil. <http://www.unicamp.br/>

^B Department of Plant Physiology and Biochemistry, Institute of Botany, São Paulo, Brazil, P.O. Box 68041, 04045-972, São Paulo, SP, Brazil. <http://www.ibot.sp.gov.br/>

^C Department of Botany, Institute of Biosciences, University of São Paulo (USP), São Paulo, SP

^D Corresponding author: Me. Nidia Mara Marchiori – nidiamarchiori@yahoo.com.br

In preparation to: "New Phytologist"

ABSTRACT

The Brazilian Atlantic Forest hosts one of the world's most diverse and threatened tropical forest biota. After five centuries of human expansion, most Atlantic Forest landscapes are archipelagos of small forest fragments immersed in an open-habitat matrix. Although the structure and composition of plant communities is known to influence the functioning of ecosystems, there is yet no agreement on how these should be described from a functional perspective. Functional diversity (FD) is a key driver of ecosystem processes and resilience to environmental change and can be measured by several indices. Nitrogen (N) is quantitatively the most abundant and essential nutrient for plant growth, it is poorly considered in traits-based and functional indices approaches and, when it appears, it is usually as total N. Based on the model of nitrogen use and considering that tropical tree species show diverse nitrogen use strategies according to their regeneration niche, our aim was to verify if functional traits associated with leaf structure and N nutrition would be useful to better characterize successional status of Atlantic Forest sites. We tested an aggregated functional indices, using three nitrogen traits considered to be relevant in determining a plant's nitrogen use strategy: leaf nitrate reductase activity (NRA), arginine (ARG) and Glutamine (GLN) contents in xylem sap, and one trait related to leaf structure: specific leaf area (SLA). All traits were weighted by the relative basal area of the species occurring in 11 forest sites in Paraíba Valley and adjacent Serra do Mar State Park. Covariation among the four traits was examined using Principal Component Analysis (PCA) and groups clustering. Jaccard similarity index

shows that species diversity in fragments was mainly guided by altitude range and climate conditions associated, while Euclidian distance and k-groups grouped fragments by their functionality. None correlations between functional indices were found and MANOVA test highlighted the variation among fragments. In the PCA ordination the first two axes explained 79.2% of total variation; the first component represented 49.1% driven by NRAagg and the second component 30.1%, driven by ARGagg. Our indices demonstrated that Fragment 1 and 7 were the most initial fragments due to higher NRAagg and SLAagg and, the other extreme were plots O, S and Fragment 5 as the most mature forest with lower values of these indices. The best indices were NRAagg and SLAagg, which defined more acquisitive strategies and sites dominated by species belonging to initial forest succession. In the other hand, ARGagg and GLNagg indices alone weren't able to distinguish successional groups, even with their strong conservative behavior as reported in many studies. This study suggests a new tool to better understand successional status of a defined forest site, based on nitrogen plant traits, especially for initial phase of succession. Literature suggests that wood density and CN could be good indicators of late succession and be used as functional indices.

Keywords: Secondary forests; Specific leaf area; nitrate reductase activity; amino acids; functional indices; basal area

INTRODUCTION

Tropical forests are extremely important for maintaining the ecological and functional relationships of the planet (Malhi et al. 2014) and they are exposed to increasing levels of human-related disturbances, including intensive logging, fragmentation and conversion of forests into pastures and agricultural purposes (Laurance et al. 2004, 2010; Joly et al. 2014). Mature forests show moderate signs of anthropogenic disturbances and are relatively stable in relation to structure, species composition and ecosystem properties, while secondary forests are dynamic forests that are recovering and intensely changing, either in composition or in functionality (Chazdon 2012). In the near future, the last tracts of old-growth forests are likely to be converted into human-modified landscapes (HML - Wright 2005; Melo et al. 2013a).

Degraded and recovering forests comprise more than half of the remaining forests on the Planet (FAO 2010), and in Brazil, less than 5% of Atlantic Forest fragments are effectively preserving native forests (Joly et al. 2014), with most of the forest fragments

being smaller than 50 ha (Ribeiro et al., 2009). Melo et al. (2013) found that human modified landscapes are widespread all over the world, composed by forest remnants mostly isolated and disconnected, with a variety of sizes, shapes and successional stages. Tabarelli et al. (2004) pointed out that after deforestation, the surrounding open area and the remnant forest influence each other and generally there is loss of biodiversity, high mortality of tall individuals due to desiccation and high irradiation, especially in the edge. Joly et al. (2014), Tabarelli et al. (2012) and Pütz et al. (2011) proposed the concept of “secondarization”, which is characterized by the domain of pioneers species, biotic homogenization and permutation of late species by pioneers in human modified ecosystems.

Studies generally agree that nutrient availability in soil changes during ecological succession (Aidar et al. 2003; Amazonas et al. 2011), however there are disagreements as to the direction and significance of these changes. Some studies suggest that the availability of all major resources (light, water, and nutrients) are high in soils that have recently been disturbed (Grime 1979), and the succession that follows involves a decrease in the availability of these resources (Vitousek et al. 1979). However, Davidson et al. (2007) indicate that in Tropical Amazon, N-cycling properties recover as secondary succession progresses, but revealing that N availability in terrestrial ecosystems is ephemeral and can be disrupted by either natural or anthropogenic disturbances at several timescales. Aidar et al. (2003) proposed that the disturbance in forests leads to a rapid production of nitrate in the soil, favoring the establishment of pioneer species that present high activity of the leaf nitrate reductase.

The understanding of the use of N and succession in the Atlantic Forest was initiated by Aidar et al. (2003), which characterized a continuum of strategies for the nitrogen use in accordance to the successional groups in Lower Montane Dense Forest (Figure 1). The proposed model was later validated by other studies in several plant communities at Atlantic Forest: Restinga (Silva, *unpublished data*), Lowland Dense Forest (Campos 2009), Lower Montane Dense Forest and Semideciduous Forest (Pereira-Silva 2008), Lower Montane Dense Forest (Silva 2012), Montane Dense Forest (Marchiori 2012; Ribeiro 2013) and Mixed Forest (Morena 2015).

Considering the validity of the nitrogen use model for the Atlantic Forest, the importance of studies involving nitrogen physiology, its limiting function for secondary forests (Raven & Andrews 2010) and the lack of studies relating forest succession and functional and physiological aspects (Amazonas et al. 2011), it is essential to develop new

tools considering plant nitrogen to evaluate ecosystems and predict how they will react to future conditions, focusing mainly in traits and functional indices that reflect the ecological strategies of the species and their response to environmental factors (Kattge et al. 2011).

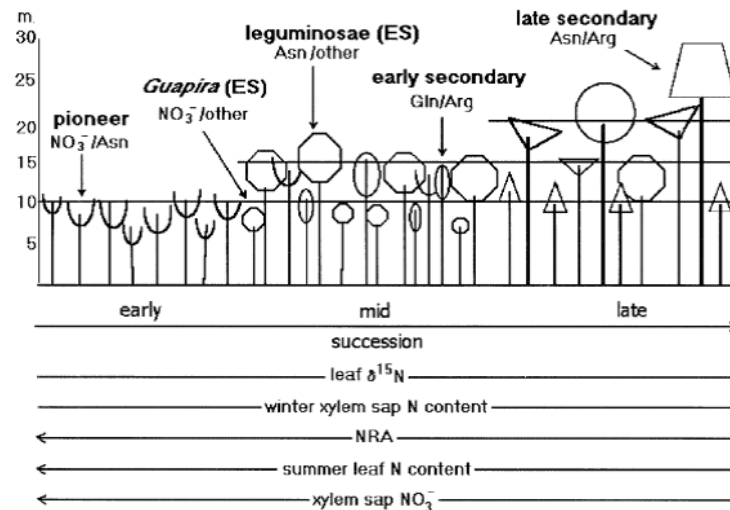

Figure 1. Conceptual diagram indicating the different strategies of nitrogen use by plants along the forest succession (Aidar et al., 2003). $\delta^{15}\text{N}$ leaf (‰); N content in the xylem sap ($\mu\text{mol mL}^{-1}$); Activity of the enzyme nitrate reductase - NRA ($\text{pkat g}^{-1}\text{FW}$); Leaf N content (%); Content of NO₃⁻ in xylem sap (%); NO₃⁻ - nitrate; Asn-asparagine; Arg-arginine; Gln-glutamine; Other, other amino acids. Initial Succession - 15 years of regeneration; Mid succession - 25 years and late succession - +36 years of regeneration after abandonment.

The extrapolation from organism level to community and ecosystems levels is one of the processes of great interest in ecology and, nowadays, there are many complex integral functions used to it (McGill et al. 2006; Garnier et al. 2004; Kerkhoff & Enquist 2006). The use of functional indices is widely applied to assess the condition of the environment or to diagnose the environmental cause of the changes (Garnier et al. 2004). The purpose influences the choice of which ecological indicators or functional indices should be used (Dale & Beyeler 2001) and they are intended to provide a simple and efficient method to examine the ecological composition, structure, and function of complex ecological systems (Dale & Beyeler 2001).

Holling (1992) suggested that the behavior of ecosystems can be understood by paying attention to a relatively small number of dominant processes operating at definable scales of time and space. According to Andreasen (2001), a good indicator should be: Multi-

scaled (depends on the scientific and management questions that are being asked); Grounded in natural history (A great knowledge about the effects of independent traits is recommended and then use them as indices); Relevant and helpful (applicable for measuring trends of concern to public and decision makers – easily understandable); Flexible (capture global and environmental changes); Measurable (able to distinguish anthropic and natural changes in many ways); Comprehensive in three aspects – Composition (key species), Structure (Amount of habitat in the landscape) and Function (Decomposition, disturbance and succession). The author also suggested arithmetic mean, weighted average and multivariate statistics as appropriate approaches to integrate all metrics included in an index.

Studies involving functional traits and indicators/indices should be based on a list of key traits that are considered to be important to the ecosystem (Bernhardt-Römermann et al. 2008) and should consider three components of ecological integrity, including composition, structure and functioning to be able to encompass all ecosystems and interactions (Noss 1990). Andreasen et al. (2001) postulated that the comparison between sites with functional index should have one "natural" or "sustainable" site, preferably located in Conservation Unit, to act as reference. In addition, it is also important to locate a reference at the "degraded" end of the spectrum to represent the other end clearly degraded and socially unacceptable. Dale & Beyeler (2001) proposed a table including some criteria for ecological indicators (Table 1).

Table 1. Criteria for ecological indicators (Dale & Beyeler 2001).

Are easily measured
Are sensitive to stresses on system
Respond to stress in a predictable manner
Are anticipatory: signify an impending change in the ecological system
Predict changes that can be averted by management actions
Are integrative: the full suite of indicators provides a measure of coverage of the key gradients across the ecological systems (e.g. soils, vegetation types, temperature, etc.)
Have a known response to natural disturbances, anthropogenic stresses, and changes over time
Have low variability in response

In this sense, it is fundamental to study the forest fragments for their recognition, quantification and management, including based on a set of new tools and approaches that could allow better understanding of the ecosystems functionality (Hobbs et al. 2009). The aim of this study is to understand how specific plant traits vary along Atlantic Forest sites with different sizes and past use and determine if functional indices based on nitrogen use strategies could group sites by their functionality and stages of succession. Our questions

are: (1) How do plant traits and functional indices vary throughout the succession of Atlantic forest fragments? (2) Is it possible to group forest fragments by similar succession based on functional indices? (3) Is it possible to define best nitrogen functional indices?

MATERIAL AND METHODS

Study sites

The region is a mosaic of small-scale agriculture, pastures, mostly young (< 10 yr) secondary forests, and remnants of old-growth forests. Ribeiro et al. (2009) suggested that secondary vegetation succession in the study region varied with former landuse, more specifically abandoned pastures versus abandoned agricultural fields, and with geomorphology and altitude. We selected eleven sites located in coastal mountain range of the Serra do Mar, in the State of São Paulo, Brazil (Table 1). These sites included two plots located in Serra do Mar State Park – Santa Virgínia Nucleus (named as O – old growth and S – secondary), and nine fragments (F1-F7, F11-F12) in private properties at São Luís do Paraitinga and Natividade da Serra – São Paulo State, bordered by pastures and cropland, with different past uses, sizes, altitudes and connectivity (Table 2, Figure 1). The soils are characterized as Red-Yellow Latosol and Haplic Cambisol (IBGE 2001).

The vegetation that composes the Serra do Mar State Park, Santa Virginia Nucleus and the forest fragments are classified as Montane evergreen forest or Montane Ombrophilous Dense Forest (“Floresta Ombrófila Densa Montana”) (Veloso et al. 1991). However, the majority of the fragments is located in a phytogeographical confluence area and predominate Ombrophilous Dense Forest with elements of Semideciduous forest and intense past use (Aguirre, 2008). Sites specific forests composition were characterized in previous studies (Old-growth – Pardgurschi et al. (2011); Secondary forest – Marchiori et al. (2017); forest fragments – Ecofor Project – *not published*). The characterization of the fragments included two plots with 0.25 ha each and all individuals with minimum diameter 10 cm (diameter above 1.3 cm from the soil).

We had very few information about the specific past use of the sites sampled and the period of the impact, however, personal communication indicated that Fragment 1 was deforested to pasture, fragment 2 remained even after the surrounding use for pasture and Fragment 3 was used as a sugar cane plantation, but we still don't know about the others fragments or further details.

Köppen (1948) assumed that the regional climate can be classified as Cwa, characterized by warm, wet summers and dry winters. The average minimum temperature is 10.6 °C, the maximum of 26.1 °C (Martins, 2010) and the average annual rainfall of 2,200 mm with the wettest months being December, January and February (Siegloch et al. 2012).

Table 2. Sites sampled at São Luis do Paraitinga and surrounding area and their characterization in species composition, structure and location. Nsp 70% BA – number of species included in the sample (basal area of the species included in 70% of the site total basal area); Alt (m.a.s.l) – altitude – mean sea level (m).

Fragment	Major species (Physionomic dominants)	nsp 70%BA	Alt (m.a.s.l.)	Area (ha)	Plot (ha)	Latitude	Longitude
F1	<i>Piptadenia gonoacantha</i>	5	920	94,6	0,5	23°15'08,62" S	45°15'03,98" W
	<i>Croton floribundus, Gymnanthes</i>						
F2	<i>klotzschiana</i>	22	920	12,2	0,5	23°16'30,98" S	45°14'28,20" W
F3	<i>Miconia dodecandra, Pera glabrata</i>	13	880	53,4	0,5	23°05'56,84" S	45°10'53,70" W
F4	<i>Tibouchina pulchra</i>	4	1150	30,3	0,5	23°16'50,12" S	45°10'24,38" W
F5	<i>Miconia sp.6, Anadenanthera colubrina</i>	8	800	24,2	0,5	23°09'39,34" S	45°27'23,85" W
F6	<i>Tibouchina pulchra</i>	19	980	30,3	0,5	23°19'27,25" S	45°11'25,40" W
F7	<i>Pera glabrata</i>	10	700	9,8	0,5	23°05'40,43" S	45°32'27,98" W
F11	<i>Cupania tenuivalvis, Eugenia sp7.</i>	20	820	85,1	0,5	23°12'40,56" S	45°16'45,14" W
F12	<i>Anadenanthera colubrina</i>	16	760	247,6	0,5	23°06'19,42" S	45°32'37,15" W
S	<i>Alchornea triplinervia</i>	14	970	old forest	1	23°19'50,60" S	45°05'67,8" W
O	<i>Chrysophyllum viride, Euterpe edulis</i>	23	1020	secondary forest	1	23°19'31" S	45°04'07" W

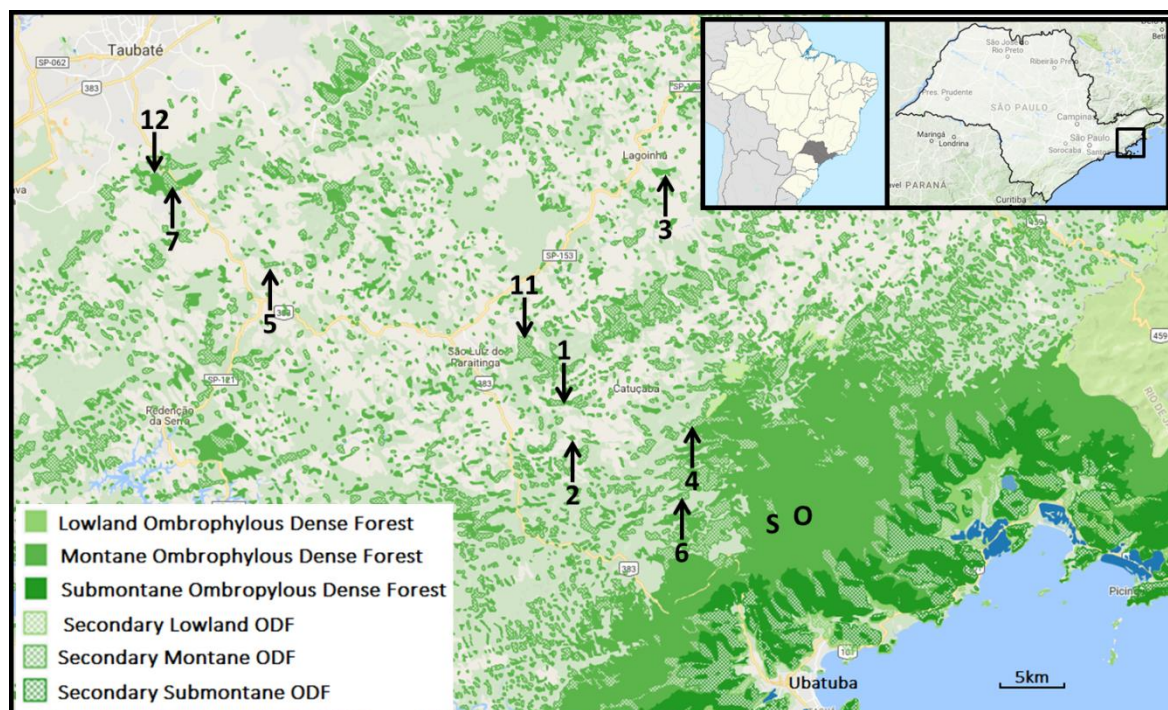

Figure 2. ECOFOR sites (BIOTA-FAPESP/NERC-UK Project). O – Old growth forests; S – Secondary forests; and Numbers – Fragments of human-modified forests. São Paulo, Brazil

Functional indices

Firstly, we tested the similarity of fragments based on their species composition by Jaccard Index and UPGMA agglomeration method. We used this analysis to evaluate if there are differences in fragments similarities and consequent clustering if we consider their composition or functionality.

The dataset consisted of trait values measured on the main species in each of the eleven sites. Measurements were conducted at wet season (summer, December – April/ 2015, 2016 and 2017), on the youngest, fully expanded leaves and totally exposed to light from three individuals of species whose correspond to 70% of total basal area of the communities (“most abundant species” hereafter). According to Mason et al. (2005), the species with the highest basal area and biomass are generally the most abundant of each ecosystem and they efficiently represent the ecosystem, as their functionality could be scaled up from the individual to the community and ecosystem level. The most abundant species have extreme functional trait values, reflecting niche partitioning and environmental heterogeneity by their functional diversity (Villéger et al. 2008).

We selected four specific plant traits to compose our functional analysis: Leaf Nitrate reductase activity (NRA), arginine (ARG) and glutamine (GLN) in the xylem sap based on nitrogen use model (Aidar et al. 2003) and Specific Leaf Area (SLA), a very common and widely used in plant traits approaches, which represents the light-intercepting area of a leaf per unit dry mass, related to net assimilation rate (Reich et al. 1997) and plant relative growth rate (RGR: Reich et al. 1997, Poorter & Jong 1999) (Table 3). These traits were chosen due their importance for ecosystem processes along forest succession (Aidar et al. 2003), such as primary production, nutrient cycling and establishment in new areas (Cornelissen et al., 2003).

The structural component of the indices was the relative basal area, as it represents both the dominance of the species and its density, being a good indicator of the composition, structure and possible changes in complexity of the community (Noss 1999). Stand basal area is also considered to be an important indicator of succession because it reflects the time since abandonment, the land use history and within-plot environmental heterogeneity with species functional traits diversity (Lebrija-Trejos et al. 2010b).

The functional indices used in this study were based on Garnier et al. (2004), presented as Equation 1. To define the functional indices, firstly we calculated the species average of each plant traits (NRA, GLN, ARG and SLA), then we weighted by the relative

basal area of the species and, to compose the aggregated index, we sum the species traits for each fragment and we have obtained four values (aggregated indices) for each fragment. We propose four aggregated indices, all related to functional dominance of the community (CWM) (Fu et al. 2014; Roscher et al. 2012 – Equation 1):

$$CWM = \sum_{i=1}^S p_i \times \text{trait}_i$$

where S is the total number of species, p_i is the relative abundance of species i, and “trait i” is the trait value of species i. When ecosystem function refers to productivity, it is reasonable to use the proportion of biomass as an indicator of the relative abundance (Garnier et al. 2004).

The choice of metrics for the ecological indices followed the criteria proposed by Andreasen et al. (2001). Leaf traits were based on a sample of three adult individuals per species, taking at least 9 leaves of each individual. The Specific Leaf Area (leaf area/leaf dry mass – $\text{m}^2\cdot\text{g}^{-1}$) is considered a key trait with well-established sampling protocols and with low error variance, details about the sample methodology could be found in Wilson et al. (1999), Garnier et al. (2001) and Cornelissen et al. (2003).

The activity of the Leaf NR enzyme was determined *in vivo* on the basis of the procedure proposed by Stewart et al. (1986) and Aidar et al. (2003). Samples (0.10 gFW) of fully expanded leaves were sliced into small fragments, vacuum infiltrated with 2.5 ml of assay solution (0.05 M KH_2PO_4 , pH 7.5, 0.1 M KNO_3 and 1.5% propanol) and then incubated 60 min in darkness at 30 °C. The nitrite was colorimetrically determined at 540 nm through a spectrometer after azocoupling with sulfanilic acid (1ml [1% (w/v) in 1.0 N HCl]) and naphthylethylenediamide dihydrochloride - NED (1ml [0.05% (w/v)]). All enzyme assays were carried out on at least duplicate samples (Stewart et al. 1986). All leaves were sampled between 9 am and 2 pm in the wet season.

The extraction of sap from xylem was performed with a manual vacuum pump in the defoliated branches and, in the laboratory, amino acid analysis was performed in UPLC (Waters Acquity UPLC® system - Waters, Milford, MA, USA). The methodology used for UPLC derivatization was Waters derivative AccQ-Tag kit protocol with the following modifications: sap samples were centrifuged for 20 minutes at 80 RPM, 10 μL of sample was added to 70 μL of borate buffer and 20 μL of 6-aminoquinolyl- N - hydroxysuccinimidylcarbamate (AQC) and then the vials were shaken for 5 minutes in vortex. The separation of aminoacids was performed with the AccQ.Tag Ultra Column C18

column (2.1 x 100 mm 1.7 μ m) at 60 °C with the following eluents: A- AccQ.Tag Ultra Eluent A (10% in water), B- AccQ.Tag Ultra Eluent B (100%), in flow rate of 0.7 mL / minute. The determination of nitrate was performed according to Cataldo et al. (1975) and used to calculate the total N in the xylem sap and then the percentage of amino acids.

Table 3. Definitions of abbreviations, acronyms, and units of variables.

Abbreviation	Definition	Units
Agg	Aggregated	
NRA	Leaf Nitrate reductase activity	pkat.FW ⁻¹
GLN	Glutamine – xylem sap	%N
ARG	Arginine – xylem sap	%N
SLA	Specific Leaf Area	m ² .g ⁻¹
PCA	Principal Component Analysis	
UPGMA	Unweighted Pair Group Method using Arithmetic averages	

Statistical analysis

After checking frequency distributions for normality, multinormality and variance heterogeneity, species-specific leaf traits values were calculated using arithmetic means prior to statistical analysis. We used both univariate and multivariate statistics to compare the differences among plant species, sizes and connectivity of the fragments and functional groups. The community functionality data were organized into one matrix, composed by four indices per fragment (total sum of traits wighted by relative basal area – Equation 1).

We used Sperman's rs coefficient to examine inter-trait correlations and Pearson coefficient to assess correlation between functional indices and a Multivariate Analysis of Variance (MANOVA) test to find the difference between fragments considering the functional indices. To test for the existence of clusters of fragments based on functional indices and plant traits, we used hierarchical agglomerative cluster analyses based on Euclidean distances and UPGMA method (Table 3). We also assessed the distribution of the groups detected by cluster analyses along functional indices using a Principal Components Analysis (PCA), based on a correlation matrix. Functional groups distribution along the PCA axes was evaluated through K-means technique. We also measured the strength of correlation between the PCA scores in the first two axes and the groups taken as ordinal variables. All

statistical analyses were carried out using R (R Development Core Team 2011), FITOPAC 2.1.2 (Sheperd 2010) e PAST 3 (Hammer et al. 2001).

RESULTS

Understanding the species composition in Atlantic Forest Fragments

We recorded and sampled 184 species in all fragments. The most frequent species in all 11 sites sampled were *Guapira opposita* (Vell.) Reitz. and *Croton floribundus* Spreng., which occurred in 7 and 5 sites, respectively. The Jaccard similarity between sampled sites was high and demonstrated they are similar in species composition with a cophenetic correlation coefficient of 0.82 (Figure 3). We found that variation in species diversity of trees in the tropical forest studied was influenced by topographic position, dominant species and probably to climate conditions and past use. The old growth site (plot O) and secondary site (plot S) are both located in Santa Virginia Nucleus, Serra do Mar State Park and, besides plot S had a history of clearcut 45 years ago, both plots have a lot of species in common (53.3% in Plot S and 34.8% in Plot O). Plot O was considered the most mature site in this study and the others sites were compared to it, in order to find successional status, as recommended by Andreasen et al. (2001).

The fragments with similar species composition were grouped, for example, Plot S, O, F4, F5 and F6 due to dominance of Melastomataceae species and absence, in the most representative species, representants from Fabaceae family. Fragments F4 and F6 are both dominated by *Tibouchina pulchra* Cogn. (Melastomataceae), a common species at secondary forest over acidic soil in Atlantic Forest, at 980-1150 m of altitude and closer to Santa Virginia Nucleus. The fragment F2 and F11 are the richest in species composition and they are located in São Luis do Paraitinga municipality (820-920 m of altitude) and have 7 species in common (mostly represented by Melastomataceae, Sapindaceae and Myrtaceae families). Even though fragment F1 and F3 are also located in São Luís do Paraitinga municipality, they are in a higher altitude than the others (880-920m) and they had some peculiarities, maybe due to past use and soil conditions. Fragment 1 is dominated by *Piptadenia gonoacantha* (Mart.) J. F. Macbr. (Fabaceae), whereas Fragment 3 was richer in species (high quantity of Melastomataceae and Peraceae) and composed by individuals with low height and diameters. Fragments F5, F7 and F12 are located near Taubaté, in the altitude range of 700-800m and

dominated by *Anadenanthera colubrina* var. *colubrina* (Vell.) Brenan. (Fabaceae) and *Miconia* sp.

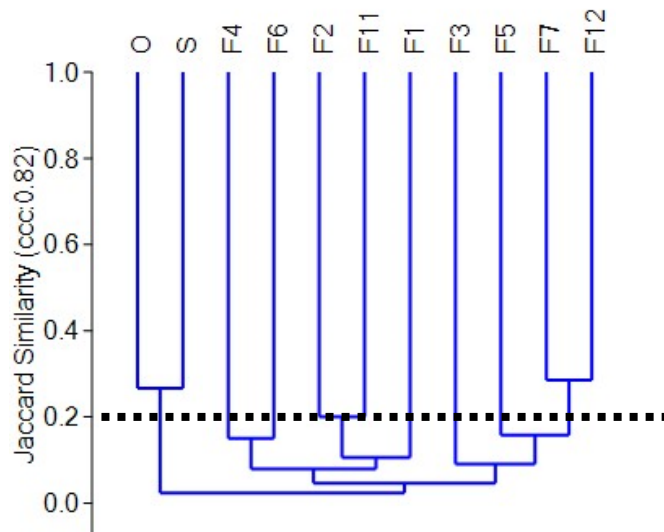

Figure 3. Cluster analysis of Atlantic Forest fragments in species composition (Jaccard Index and UPGMA agglomeration method – cophenetic correlation: 0.82). The dotted black line indicates the point where groups are separated.

Functional indexes as a tool to assess status of succession along a disturbance gradient

Plant traits (NRA, SLA, ARG and GLN) dataset did not follow normality distribution, but the functional indices (NRAagg, SLAagg, ARGagg and GLNagg) dataset followed multinormality (Doornik and Hansen omnibus - Ep: 5.467, p (normal): 0.7067). In this study, we asked how functionality change during secondary tropical forest succession, and if functional indices could lump fragments by their stages of succession. Firstly, we investigated the patterns of chosen plant traits in the fragments (Figure 3) and we noticed a significant statistical differences by Kruskal-Wallis test and post hoc Mann-Whitney between fragments (SLA – H: 62.57, p: 1.18E-09; NRA – H: 20.44, p: 0.02; GLN – H: 46.03, p: 1.4E-06; ARG – H: 36.8, p: 5.547E-05), reinforcing the importance of these traits to distinguish between fragments.

Considering plant traits (Figure 4), we noticed that they varied widely between species and fragments. Fragment 3 and 4 had low SLA and NRA. Fragments 4, 5 and Plot S showed high content of GLN, these two results could be explained by the dominance of Melastomataceae species, frequently showing lower NRA and high GLN content. Fragment 12 had high SLA and Fragment 1 high NRA. The content of ARG and GLN in the sites were

similar ($p>0.05$), however, Fragment 4, 5 and Plot S had at least 8% more glutamine than arginine in xylem sap, while F11, F12 and Plot O predominate arginine content. Spearman's r_s correlations revealed a significant correlation between SLA and NRA (Spearman's $r_s=0.63$, $p=0.03$) and SLA and GLN (Spearman's $r_s=0.79$, $p=0.003$).

All species examined in this study showed flexibility in resource use of chemical forms of soil N along fragments. One example of the great plasticity in species functionality could be *Guapira opposita* (Vell.) Reitz.: the average NRA in the most preserved sites (plot O and S) were $77.93 \text{ pKat gFW}^{-1}$, in fragment 11 and 12, the specie had very distinct NRA, 108.73 and $41.31 \text{ pKat gFW}^{-1}$, respectively. In fragment 7 the NRA was $268.66 \text{ pKat gFW}^{-1}$.

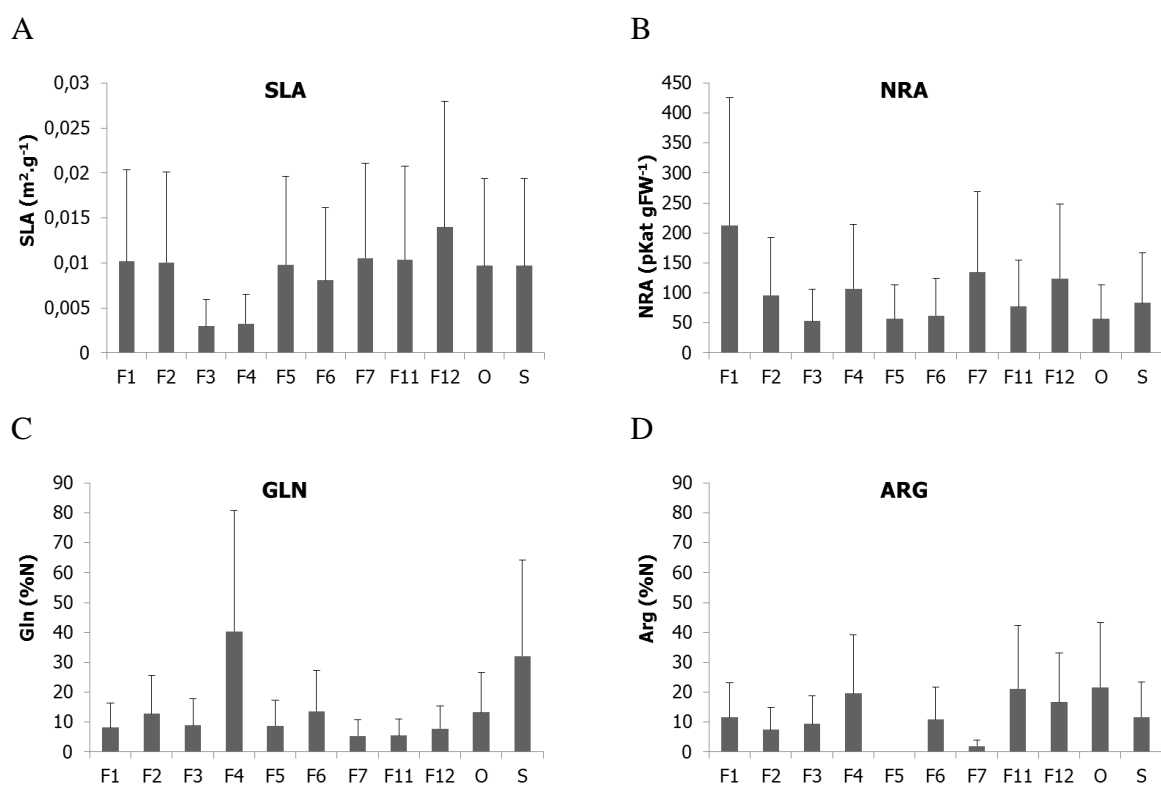

Figure 4. Plant traits response in Atlantic Forest fragments and their respective standard deviation. (A) SLA – Specific Leaf Area, (B) NRA – Nitrate Reductase Activity, (C) GLN – Glutamine in the xylem sap; (D) ARG – Arginine in the xylem sap.

After understanding the plant traits, we investigated the functional indices (SLA_{agg}, NRA_{agg}, GLN_{agg}, ARG_{agg}). None of the functional indices were significantly correlated by Spearman's r_s Correlation Coefficient and MANOVA test (Table 4) showed differences between fragments. Fragment 1 and 4 had distinct functional indices and were different to all other sites. Plot O was only statistically different from F1, F7 and F12 and,

based in our functional approach, these forest fragments are probably the most initial sites (Table 4). Functional indices were also different between each other (H (chi2): 389.6, p (same): 3.753E-84), except for ARGagg and GLNagg (p=0.9619).

Table 4. Multivariate analysis of variance test (MANOVA) to demonstrate the differences between fragments regarding their Specific leaf area, nitrate reductase activity, glutamine and arginine content in the xylem sap.

	F1	F2	F3	F4	F5	F6	F7	F11	F12	O	S
F1		0.0000166	0.0002868	0.0009288	0.010045	0.0000352	0.042758	0.0000049	0.0005963	0.0000073	0.0001081
F2	0.0000166		0.33157	0.0064358	0.63378	0.63453	0.014602	0.35073	0.16964	0.6087	0.41157
F3	0.0002868	0.33157		0.0002502	0.12141	0.23828	0.0058765	0.12975	0.013817	0.46284	0.56642
F4	0.0009288	0.0000006	0.00025025		0.0004521	0.0000347	0.0000167	0.0000011	0.0000081	0.0000053	0.0003311
F5	0.010045	0.63378	0.12141	0.00045216		0.34927	0.5127	0.26031	0.76674	0.1511	0.17177
F6	0.0000352	0.63453	0.23828	0.0000347	0.34927		0.0040091	0.14357	0.05418	0.49494	0.71855
F7	0.042758	0.014602	0.0058765	0.0000167	0.5127	0.0040091		0.0089423	0.19833	0.0009938	0.0029554
F11	0.0000493	0.35073	0.12975	0.0000011	0.26031	0.14357	0.0089423		0.36889	0.26332	0.042917
F12	0.0005963	0.16964	0.013817	0.0000008	0.76674	0.05418	0.19833	0.36889		0.019427	0.0092409
O	0.0000007	0.6087	0.46284	0.0000053	0.1511	0.49494	0.0009938	0.26332	0.019427		0.5893
S	0.0001081	0.41157	0.56642	0.0003311	0.17177	0.71855	0.0029554	0.042917	0.0092409	0.5893	

The cluster analyses provided an evidence of statistically significant groups within the functional indices variation space, however the groups found in functional analysis (Figure 5) were very different from those grouped by floristic similarity (Figure 3). The dendrogram based on Euclidian distance and UPGMA method produced the largest Agglomerative Coefficient (0.77) (Figure 5). In figure 5 is possible to noticed two clearly disticted groups, one composed by Plot O, Plot S, F4, F5 and F6 and the other composed by F1, F2, F3, F7, F11 and F12. It is also possible to group fragments in four functional groups: F1 and F7; F2, F3, F11 and F12; F5, F6, S and O and F4 alone. Results were similar to those obtained by PCA (Figure 6) and k-means groups (Table 4), except for F4 which group with F6 in PCA and k-means tests.

The Principal Component Analysis (Figure 6) carried out on the four indices, accounted for 79.2% of total variation, the first component represented 49.1% of the total variation, being represented mainly by NRAagg (61.5%), while the second component (PC2: 30.1%) were guided by ARGagg (83.7%). We noticed that nitrogen and SLA indices also lumped two groups and, with more details, is possible to join fragments in four groups, as well as in Figure 6. Is clear that one group have high NRAagg and SLAagg (more acquisitive strategies) and the other group has low values of these traits and high ARGagg and GLNagg, being classified as more conservative strategies. The linear regression between PC1 and PC2

of the PCA demonstrated that axis were not correlated ($r: -0.18791$; $r^2: 0.035309$; $t: -0.57394$; $p(\text{uncorr.}):0.58007$). Using the K-means groups we found four functional groups (Table 5).

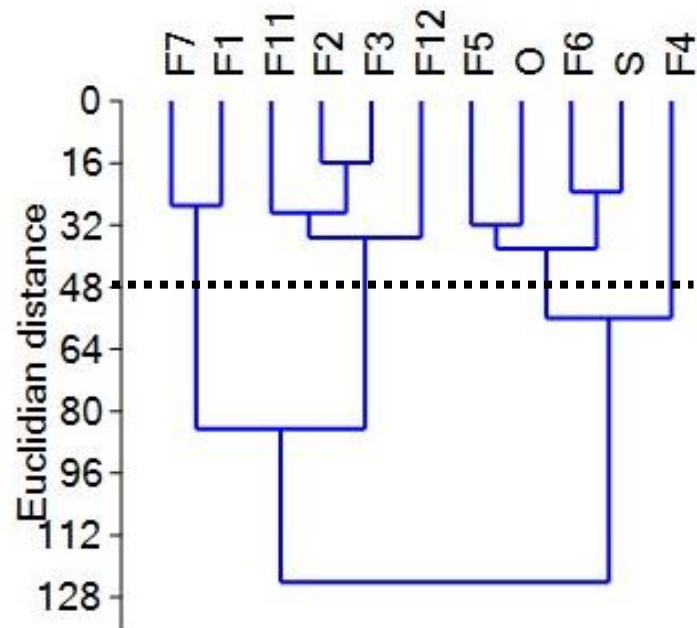

Figure 5. UPGMA dendrogram-based in four functional indices at eleven fragments. Numbers above branches indicate the Fragment number (ccc:0.74).

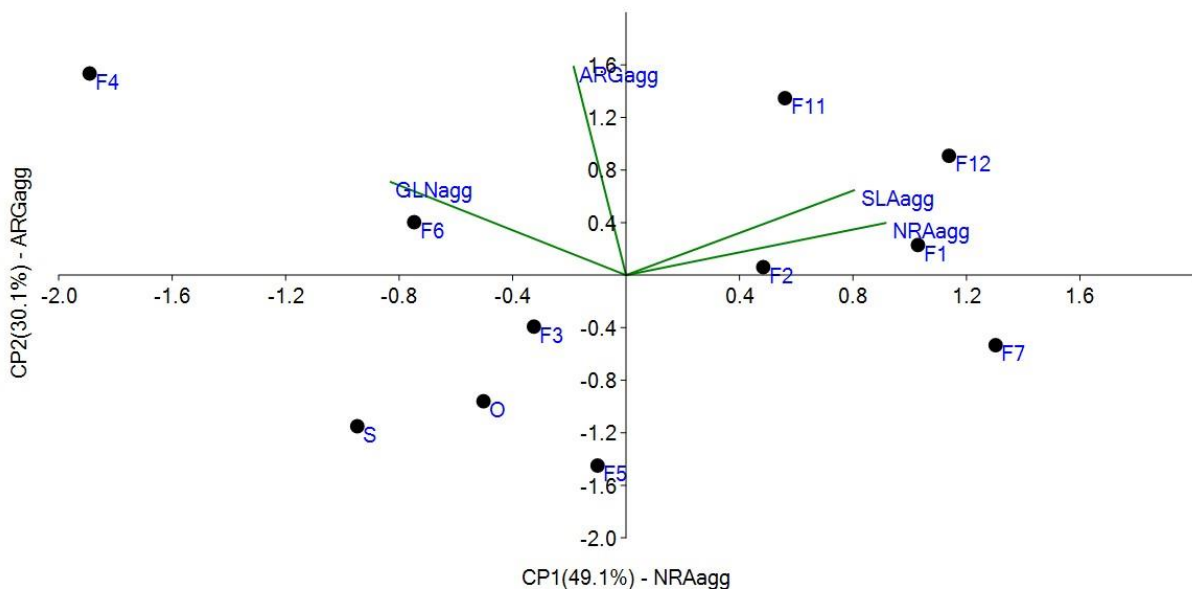

Figure 6. Principal Component Analysis carried out on eleven sites, characterized by four functional indices (NRAagg, SLAagg, ARGagg and GLNagg). The four functional indices are represented in the vectors.

Table 4. Functional groups along a gradient disturbance in Atlantic Forest sites. Each group was composed by different number of species and fragments and was characterized by functional indices in Low (*), Medium Low (**), Medium High (***) and High (****).

Group	Sites	SLAagg	NRAagg	GLNagg	ARGagg	
I	F1, F7	**	****	*	*	FAST
II	F2, F3, F11, F12	**	***	**	***	↓
III	F4, F6	**	*	****	***	
IV	F5, S, O	*	*	**	*	SLOW

DISCUSSION

In this study we analyzed plant trait and functional groups distributions as indicators of changing drivers of species dominance and functionality during secondary succession and we found that nitrogen indices could be used as a tool to define successional status. Nowadays, only 7.6% of patches larger than 100 ha of the Atlantic Forest still remains (Joly et al. 2014). It is known that the velocity and recovery of the species diversity and species functionality after a disturbance depends on the intensity of the impact (Guariguata & Dupuy 1997).

Tabarelli et al. (1999) studied the changes in the species composition in four plant communities with different successional stages (10, 18, 40 years old and mature), all of them located in a montane rainforest (Serra do Mar State Park) and deforested by short cut to pastures establishment. The authors noticed that Myrtaceae, Lauraceae, Melastomataceae and Rubiaceae were the most representative families for this Atlantic Forest physiognomy. However, Melastomataceae and Rubiaceae predominate in the beginning of the succession and Myrtaceae and Lauraceae tend to dominate in the end of succession. *Tibouchina pulchra*, *Miconia* sp. and *Leandra* sp. (Melastomataceae) dominated communities with 10-40 years old, being followed by communities with *Alchornea* spp. Guariguata & Ostertag (2001) found the same pattern in moist and wet Neotropics after site abandonment, i.e., vegetation dominated by grasses, shrubs, forbs and short-lived, light-demanding “pioneer” tree species in particular *Cecropia*, *Solanum* and many tree species in the Melastomataceae and Rubiaceae. After the first period of succession, the canopy is dominated by long-lived, taller-statured, but nevertheless light-demanding tree species in the genera *Alchornea*, *Cordia*, *Inga*, *Jacaranda*, *Simarouba*, *Trema*, *Vochysia* and *Vismia*.

Our results are very similar to those obtained by Tabarelli et al. (1999) and Guariguata & Ostertag (2001): fragments 3, 4, 5 and 6 were dominated by Melastomataceae, especially by *Tibouchina pulchra* and *Miconia* spp.. The others fragments were represented by Euphorbiaceae family, including *Croton floribundus* Spreng., *Gymnanthes klotzschiana* Müll.Arg. (classified as pioneer and early secondary, respectively), Sapindaceae - *Cupania tenuivalvis* Radlk.(early secondary), Fabaceae - *Piptadenia gonoacantha* (Mart.) J. F. Macbr. (pioneer), *Anadenanthera colubrina* (Vellozo). Brenan (early secondary) and Peraceae - *Pera glabrata* (Schott) Poepp. ex Baill. (pioneer). The most abundant species found in Serra do Mar State Park plots were *Alchornea triplinervia* (Spreng.) M. Arg. (early secondary – Euphorbiaceae) at plot S and *Chrysophyllum viride* Mart. & Eichler (late secondary – Sapotaceae) and *Euterpe edulis* Mart. (late secondary – Arecaceae) at plot O.

We also find a Legume dominance across successional gradients in the Atlantic Forest. While we did not find Leguminosae/ Fabaceae species in the most representative species in plot O (mature), fragment 1 was dominated by *P. gonoacantha*. This increasing in Fabaceae species occurrence in secondary sites probably is due the nutrient demand of regrowing tropical forests may be partly satisfied by their capacity to fix nitrogen (Siddique et al. 2008). Epihov et al. (2017) highlighted that N₂-fixing legumes provided approximately 50% of the N required for early growth of Panamanian secondary rainforests, providing N for photosynthesis and biomass accumulation. Siddique et al. (2008) also find that the use of legumes during the forest may assist early tree survival and optimize biogeochemical effects of mixed plantings, as they enhance the nitrogen input. Tabarelli et al. (1999) indicated a predictable shifts in plant guild structure as montane Atlantic Forest fragments are reduced in size with marked rise in the relative importance of ruderal species, including Leguminosae family.

The changes in forest structure and species composition along succession strongly imply concurrent changes in both functional diversity and ecosystem functioning. More recently, several studies have suggested that ecosystem function is dependent not on the number of species itself, but on the functional traits of the species (Hooper et al. 2005, Mason et al. 2005). It is well known that species richness increases asymptotically during secondary succession (e.g. van Breugel et al., 2006; Norden et al., 2009; Lebrija-Trejos et al., 2010a), however Tabarelli et al. (1999) suggest that the functionality recuperate more slowly than species composition after a forest disturbance. Disturbance altered the link between species

and functional richness, and this relationship depends on the traits considered (Mayfield et al. 2005).

In addition, species could exhibit variation in their functional traits due to the limitations of species distributions (Diaz & Cabido 2001; Leps et al. 2006). Therefore, communities with the same species richness may exhibit great functional differences due to various species traits (Leps et al. 2006; Roscher et al. 2012) and their redundancy (Mouchet et al. 2010). Compared with taxonomic diversity, functional characteristics better reflect the differences in species functional traits, which in turn explain the variation in community productivity (Fu et al. 2014; Li et al. 2015; Tobner et al. 2016). Fonseca & Ganade (2001) calculated that 75% of species could be lost from an Argentinean plant community by random extinction before functional group richness would decrease, illustrating the divergence and redundancy between species and functional richness (Cadotte et al. 2011).

Andersen & Turner (2013) and Houlton et al. (2007) found similar results and suggest that tropical plants are flexible in their N uptake strategies depending in the N form and availability. In addition, Houlton et al. (2007) proposed that tropical plants are evolutionarily predispositioned to plasticity in the chemical form of N taken up in order to minimize the cost of N uptake, because the relative availability of the chemical N forms change in time and space.

NRA indicates availability of nitrate in the soil (Vitousek et al. 1979) and, in the early phase of secondary succession following disturbance, soil nitrate is produced in abundance, resulting in a competitive advantage for pioneer plants (Stewart et al. 1990). Pioneer species (with high nitrate reductase activity) utilize the extra soil nitrate and present high foliar nitrogen content [$\mu\text{mol (g dry weight)}^{-1}$] especially in early stages of regeneration, compared with the same species surviving in the mature forest (Stewart et al. 1988; Aidar et al. 2003). Lamb (1980) perceived an increase of nitrification and nitrate availability after a disturbance and the invasion by pioneer-phase species, which have all the attributes for nitrate utilization and high photosynthetic rates to “exploit” this new condition. However, many pioneer rainforest species persist as soil nitrification declines over the first ten years of secondary succession, and will continue to survive, in partial shade, for many years thereafter as the rainforest regenerates (Stewart et al. 1990). Same results were obtained by Wardle (2002), who also find that apparent rates of net nitrification were generally lower in systems dominated by later successional plant species than in early successional stages. Contrasting results have been found by Aidar (2003) who showed that, in Brazilian south-eastern

rainforests, NH_4^+ availability was higher than that of NO_3^- in the early successional phase, maybe due to nutrient exhaustion of the soil following cultivation and most probably due the higher soil mobility of NO_3^- by lixiviation for instance, when compared to NH_4^+ .

Diaz & Cabido (2001) find that communities dominated by fast-growing plants tend to have high resilience and low resistance while opposite features for communities dominated by slow-growing plants are seen. The pioneer species are distributed in areas of clearings or edges, where luminosity is not a limiting factor. Thus, they are endowed with a more intense photosynthetic activity supplying energy demand for the NRA (Hikosaka & Osone 2009). The NR is a cytoplasmic enzyme, it demands NAD(P)H generated in electron transport process during photosynthesis (Abrol et al. 1983). As energy for NO_3^- assimilation in the leaves may be provided by photosynthetic light reactions, the use of this N source is advantageous in environments where the light is not a limiting factor (Smirnoff & Stewart 1985). Shade plants have less advantage in the assimilation of NO_3^- in the leaves due to the limitation of photosynthesis by light (Oliveira et al. 2017).

Using a trait-based approach, we could notice that species with high NRA also had big leaves and high SLA. The positive correlation between SLA and NRA reinforce that both traits are directly involved in photosynthesis, plant growth and acquisitive strategies (de Vries & Bardgett 2016), whereas the negative correlation between NRA and GLN demonstrate the opposite strategies, indicating that GLN indicates more conservative strategy, due to nitrogen assimilation, transamination and transportation along xylem sap. SLA had been chosen because it is among the most important and commonly studied traits and is of paramount importance for different ecosystem processes (Lavorel & Garnier 2002; Chave et al. 2009), affecting primary production, carbon and nutrient cycling and litter decomposition (Poorter et al., 2009). According to Cornelissen et al. (2003), plants growing under high light exposure generally show low SLA and thicker leaves, on the other hand, shade leaves tend to show less thick leaves and with lower concentrations of photosynthetic enzymes per area, which increases their SLA (Westoby et al., 2002; Prado Junior et al. 2015). Studies demonstrated a positive correlation between the intensity or frequency of disturbances and SLA in a plant community (Reich et al., 2003; Garnier et al., 2004). However, Prado Junior et al. (2015) noticed an opposite relationship between SLA and disturbance with understory species, that is, they showed a decrease in the SLA of understory species with the increase in the disturbance intensity.

GLN is a long-distance transport amino acid and as a primary product of inorganic N assimilation which requires relatively little energy for its formation (Stewart et al. 1980; Lea & Miflin 1980), thus, the increasing in the concentration of this amino acid indicates assimilation of new N (Liu et al. 2016). In plants, inorganic nitrogen (i.e. NO_3^- and NH_4^+) taken up by roots is incorporated into glutamine and glutamate (primary nitrogen assimilation), which is used to synthesize other amino acids and nitrogenous compounds by transamination (Okumoto & Pilot 2011).

Among the 21 proteinogenic amino acids, arginine has the highest nitrogen to carbon ratio (6 C: 4N), which makes it especially suitable as a storage and transport form of organic nitrogen (Winter et al. 2015), it is also important for transportation by its solubility in the sap (Micallef & Shelp 1989; Schmidt & Stewart 1998), especially during the first 15 d after bud burst followed by glutamic acid and citruline (Frak et al. 2002) and during the winter (Aidar et al. 2003). Arginine metabolism plays a key role in nitrogen distribution and recycling in plants (Slocum 2005) and its utilization seems to be coordinated with the availability of carbohydrates (Winter et al. 2015), highlighting an opposite relation to photosynthesis and acquisitive strategies. It is thus conceivable that arginine catabolism serves on the one hand to mobilize nitrogen storages, while on the other hand it may be used to fine-tune development and defence mechanisms against stress (Winter et al. 2015).

According to Frak et al. (2002) the amino acids arginine, citruline, γ -amino butyric acid, glutamic acid and aspartic acid always represented around 80% of total amino acid and amide N in xylem sap. Aidar et al. (2003) found that pioneers species transport mostly nitrate + asparagine in their xylem sap, whereas early secondary species transport glutamine + arginine and the late secondary species transport asparagine + arginine. Our results showed that dominant species in sampled fragments had different content of arginine and glutamine as a trait. However, these two amino acids were correlated when they were transformed into functional indices (Table 3). Based on that, we conclude that ARGagg and GLNagg had the same functional response and, based on N use model (Aidar et al. 2003), they should indicate non-pioneer strategies. GLNagg could highlighted different successional groups and the content of this aminoacid, as well as ARGagg, were influenced by species composition of the site. F4, F5 and F6 were dominated by *T. pulchra* and *Miconia* spp. and both are known to have high content of these both aminoacids in their xylem sap (Table 4). In this way, these two indices, especially ANRagg, were not completely efficient to demonstrate the mature characteristic of reference plot (Plot O). Amino acid composition of the xylem sap

exhibits seasonal variations and significant diurnal trends (Frak et al. 2002), probably associated to the variations in expression of amino acid transporter genes (Couturier et al. 2010) and soil nitrogen availability. Arginine predominates during winter (Aidar et al. 2003) and glutamine and glutamate during the growing season (Couturier et al. 2010), and probably this would explain the high content of glutamine found in our study. We noticed some constraints in our functional indices using aminoacids and probably we would have had better results to use them for conservative strategies if we associate them with other traits, maybe wood density, total carbon or even species richness (Lohbeck et al. 2012) and include winter in the sampling protocol (Aidar et al. 2003).

The functional indices were composed by plant traits associated to nitrogen assimilation and transportation and related to growth. SLA and NRA are considered soft and easy to measure plant traits, however ARG and GLN are both hard traits, as they have to be measure by chromatographic techniques. Results comparing the functional indices indicated differences between sites and they could indicate the most pioneers fragments at Atlantic Rainforest (Figure 5, Figure 7). The first two axes confirmed the application of the fast–slow or acquisitive-conservative nitrogen use, NRAagg and SLAagg as acquisitive and ARGagg as conservative axis. The most initial sites were F1, F12, F7, F2, F3 and F6, which had species with long, narrow leaves (SLA) and with high activity of nitrate reductase activity. Fragments F4, F11, F5, K and T had low NRAagg and SLAagg and they probably are influenced by others plant traits, which were not considered in this study (wood density, total carbon, carbon:nitrogen ratio). These changes from conservative, (especially represented by plot O) to acquisitive strategies suggest that abiotic filtering is an important process in community assembly early in Tropical forest succession, including nutrient availability and climate conditions (Purschke et al. 2013). Spatial heterogeneity in chemical forms of N can arise along environmental gradients such as precipitation (Houlton et al. 2007) or soil nutrients (Marrs et al. 1988) and can influence in species redundancy and resilience (Díaz and Cabido 2001).

Stewart et al. (1990) examined nitrate reductase activity, specific leaf area, leaf dry matter content and chlorophyll a and b content in two closed-forest communities and eight open-forest communities in southeastern Queensland, Australia. They noticed that the increase in the nitrate reductase activity along sites was followed by an increase in total chlorophyll content (per unit dry weight), the proportion of chlorophyll b to chlorophyll a and with activity of the chloroplastic isoform of glutamine synthetase, indicating the positive

correlation between nitrogen and carbon metabolism (Stewart et al. 1988). They also find a continuum of nitrate reductase activity along open-forest sites, which decreased from pioneer to mature-phase species and increased in more favourable water relations (from subhumid to perhumid climates). This increase in nitrate reductase activity was associated with a decrease in cellulose and lignin (per unit dry weight of leaf) (Stewart et al. 1990).

During our search to first develop our indices, we noticed two complementary ways to quantify the functional trait properties of biodiversity that imply different mechanisms by which biodiversity influences ecosystem processes: functional diversity and community-weighted functional trait mean. Functional diversity (FD) describes the distribution of species in functional trait space (Mason et al. 2005) and is highly influenced by species diversity in the communities. On the other hand, the community-weighted means (CWMs) describe the dominant functional trait value of the overall community, by weighting species trait values by the abundance of the species (Lavorel et al. 2007).

CONCLUSION

A functional analysis of vegetation may help to understand and predict the impact of secundarization in tropical forest in a more general way. We could group fragments by their functional indices and suggest successional stages. The majority of fragments could be defined by NRAagg and SLAagg, which were both indicative of more acquisitive strategies. In the other hand, besides studies for community highlight the importance of GLN and ARG as indicative of early/late secondary strategies, when weighted by basal area to develop functional indices, they had the same response to ecosystems change and could only indicate nitrogen strategies instead of successional stages. Selection of functional trait(s) critically determines FD, with large consequences for studies relating biodiversity to ecosystem functioning. Careful consideration of the traits required to capture the ecosystem process of interest is essential and we strongly suggest more studies to classify late secondary or non-pioneer strategies.

ACKNOWLEDGEMENTS

This work is the product of EcoFor Project founded by Biota-FAPESP and UK Natural Environment Research Council (NERC) (Fapesp 2012/51872-5) and National Council for Scientific and Technological Development (CNPq and Capes) funding to N.M.M. We also thank Renato Belinello (UNICAMP, Brazil), Santa Virginia Nucleus Administration

and owners of forest fragments sampled for providing valuable support and advice. Thanks also to Wagner Toledo for assistance in the field. COTEC/IF 002.766/2013 e 010.631/2013 permitted the development of this study.

AUTHOR CONTRIBUTIONS

N.M.M. and M.P.M.A. planned and design the nitrate reductase activity analysis, M.A.M. and M.P.M.A planned and designed the structural and photosynthesis traits analysis, N.M.M., D.M., S.L.R., M.A.M., F.F. L.H. and H.B.B. conducted fieldwork and analyzed data. N.M.M. and M.P.M.A. wrote the manuscript, with contributions from all authors.

CONCLUSÕES GERAIS

1. O estudo de meta-análise demonstrou que, no geral, as variáveis nitrato redutase, conteúdo de nitrato e arginina na seiva do xilema foram eficientes para distinguir entre estratégias pioneiras e não-pioneiras;
2. O modelo de efeitos aleatórios foi a técnica escolhida devido a grande heterogeneidade entre os casos estudados;
3. O efeito geral da variável arginina na meta-análise foi negativo, indicando alto conteúdo desse aminoácido em espécies tardias, contudo com alta variância.
4. A atividade da enzima nitrato redutase foi abordada em maior número de estudos e florestas e técnicas semelhantes. Essa variável foi a mais eficiente em distinguir grupos sucessionais, com baixa variância intra-grupos;
5. O nitrato na seiva xilema também foi um bom preditor de grupos sucessionais;
6. Apesar do grande esforço amostral, o número de estudo que se enquadraram nos critérios previamente definidos foram poucos. Isso demonstra a demanda por mais estudos nessa área, especialmente para florestas tropicais. Os estudos envolvendo NRA com abordagem ecológica são pouco frequentes. Apesar de ser uma enzima com grande facilidade de obtenção e resultados interessantes;
7. As variáveis amostradas na metanálise foram avaliadas para posteriormente ser utilizadas como índice para classificar não somente as estratégias sucessionais de uma dada espécie, mas sim de um ecossistema, através de índices funcionais. Verificamos que a atividade da enzima nitrato redutase (NRA) é a melhor variável relacionada ao uso de nitrogênio, pela sua característica altamente distintiva entre Pi e NP_i e baixo desvio padrão;
8. A NRA é negativamente correlacionada com densidade da madeira e massa foliar por área de folha, reforçando a característica aquisitiva dessa variável, assim como a fotossíntese.
9. As famílias Urticaceae e Asteraceae formaram um dos extremos do trade-off aquisitivo-conservativo, sendo influenciadas pela NRA e Asat (a), enquanto que Lauraceae e Chrysobalanaceae formavam o outro extremo da funcionalidade, guiado pela densidade da madeira e conteúdo de massa seca;
10. Os atributos LMA, LDMC, Asat(a), WD e NRA diferenciaram a funcionalidade dos grupos sucessionais, assim, fica claro a distinção do trade-off, com NRA, Asat(a) e

SLA representando espécies pioneiras e WD, LDMC e LMA representando espécies não-pioneiras;

11. A análise das variáveis de uso de nitrogênio tem sido amplamente estudada na escala de comunidade, contudo, associando com a área basal das espécies dominantes, desejamos indicar índices que sugiram o estágio sucessional de fragmentos de Mata Atlântica com tamanhos, altitudes, históricos e composição florística distintos;
12. Não houve grande correspondência entre a diversidade florística dos fragmentos com a diversidade funcional, provavelmente devido à redundância funcional ou da influência do filtro local da funcionalidade do fragmento;
13. Verificamos correlação positiva entre SLA-NRA e SLA-GLN nos fragmentos. SLA e NRA se relacionam com o potencial de crescimento da espécie, relacionados com alta área foliar para fotossíntese e geração de energia para a enzima nitrato redutase. Por outro lado, a relação entre SLA e GLN pode ser relacionada com transpiração e transporte no xilema, visto que o aminoácido Glutamina é o principal aminoácido de transporte.
14. Considerando os índices funcionais, somente houve semelhança estatística entre ARGagg and GLNagg, indicando que esses aminoácidos representam estratégias similares na obtenção de recursos e não são eficientes para distinção ou classificação de estágios sucessionais de fragmentos, sendo necessário um teste com outros atributos funcionais;
15. Verificamos através dos índices funcionais relacionados ao uso de N que os fragmentos mais iniciais na sucessão são os Fragmento 1 e fragmento 7, enquanto que os mais avançados na sucessão são os plots localizados na Unidade de conservação (Plot O e S). Os fragmentos 4, 5 e 6 estão mais associados com os Plots O e S principalmente pela composição florística (dominância por representantes da família Melastomataceae). Cabe ressaltar que os fragmentos 4 e 6 estão localizados muito próximo à unidade de conservação e apresentam dominância de *Tibouchina pulchra*, espécie secundária inicial característica da Floresta Ombrófila Densa. Contudo, os plots O e S são, de fato, os mais preservados, indicando que para os índices considerados no presente estudo são eficientes para distinguir fragmentos e estratégias pioneiras, sendo necessário outros atributos para classificar fragmentos tardios, provavelmente densidade da madeira (WD) ou carbono (C) total. Também, cabe avaliar a utilização da riqueza como composição do índice funcional.

REFERÊNCIAS BIBLIOGRÁFICAS

- Abrol, Y.P., Sawhney, S.K. & Naik, M.S. 1983. Light and dark assimilation of nitrate in plants. *Plant Cell and Environment*, 6:595-599.
- Adams, M.A. & Attiwill, P.M. 1982. Nitrate reductase activity and growth response of forest species to ammonium and nitrate sources of nitrogen. *Plant and Soil*, 66 (3): 373-38.
- Aguirre, G.H. 2008. Caracterização da vegetação arbustivo-arbórea de fragmentos de Floresta Ombrófila Densa Montana. Dissertação (mestrado) – Universidade Estadual de Campinas, Instituto de Biologia. 120 p.
- Aidar, M.P.M.; Schmidt, S.; Moss, G; Stewart, G.R. & Joly, C.A. 2003. Nitrogen use strategies of neotropical rainforest trees in threatened Atlantic Forest. *Plant Cell and Environment*, 26: 389-399.
- Aide, T.M.; Clark, M.L.; Grau, H.R.; López-Carr, D.; Levy, M.A.; Redo, D.; Bonilla-Moheno, M.; Riner, G.; Andrade-Núñez, M. J. & Muñiz, M. 2013. Deforestation and reforestation of Latin America and the Caribbean (2001-2010). *Biotropica* 45: 262–271.
- Aide, T.M. & Grau, H.R. 2004. Globalization, migration and Latin American ecosystems. *Science* 305: 1915–1916.
- Amazonas, N.T.; Martinelli, L.A.; Piccolo, M.C. & Rodrigues, R.R. 2011. Nitrogen dynamics during ecosystem development in tropical forest restoration. *Forest Ecology and Management*, 262:1551–1557.
- Andersen, K.M. & Turner, B.L. 2013. Preferences or plasticity in nitrogen acquisition by understorey palms in a tropical montane forest. *Journal of Ecology*, 101:819–825
- Andreasen, J.K.; O'Neill, R.V.; Noss, R. & Slosser, N.C. 2001. Considerations for the development of a terrestrial index of ecological integrity. *Ecological Indicators*, 1: 21–35
- Andrews, M. 1986. The partitioning of nitrate assimilation between root and shoot of higher plants. *Plant Cell and Environment*, 9:511-519.
- Apgaua D.M.G; Tng D.Y.P; Cernusak, L.A; Cheesman A.W.; Santos, R.M.; Edwards, W.J. & Laurance, S.G.W. 2017. Plant functional groups within a tropical forest exhibit different wood functional anatomy. *Functional Ecology* 2017, 31, 582–591.
- Arroyo-Rodríguez V.; Melo F.P.L.; Martínez-Ramos M.; Bongers F.; Chazdon R.L.; Meave J.A.; Norden N.; Santos B.A.; Leal I.A. & Tabarelli M. 2017. Multiple successional

- pathways in human-modified tropical landscapes: new insights from forest succession, forest fragmentation and landscape ecology research. *Biological Reviews*, 92: 326–340.
- Ashton, I.W.; Miller, A.E.; Bowman, W.D. & Suding, K.N. 2010. Niche complementarity due to plasticity in resource use: plant partitioning of chemical N forms. *Ecology*, 91: 3252–3260.
- Attiwill, P.M. & Adams, M. 1993. Nutrient cycling in forests. *New Phytologist*, 124:561–582.
- Baltzer, J.L.; Gregoire, D.M.; Bunyavejchewin, S.; Noor, N.S.M. & Davies, S.J. 2009. Coordination of foliar and wood anatomical traits contributes to tropical tree distribution and productivity along the Malay-Thai peninsula. *American Journal of Botany*, 96: 2214–2223.
- Baraloto, C.; Paine, C.E.T.; Poorter, L.; Beauchene, J.; Bonal, D. et al. 2010. Decoupled leaf and stem economics in rain forest trees. *Ecology Letters*, 13:1338–1347.
- Bazzaz, F.A. & Pickett, S.T.A. 1980. Physiological ecology of tropical succession: a comparative review. *Annual Review of Ecological Systems*, 11:287-310.
- Becker, T.W.; Foyer, C. & Caboche, M. 1992. Light-regulated expression of the nitrate reductase and nitrite reductase genes in tomato and in the phytochrome-deficient aurea mutant of tomato. *Planta*, 188:39-47.
- Beevers, L. & Hageman, R.H. 1969. Nitrate reduction in higher plants. *Annual Review of Plant Physiology*, 20:495-522.
- Bernhardt-Römermann, M.; Römermann, C.; Nuske, R.; Parth, A.; Klotz, S.; Schmidt, W. & Stadler, J. 2008. On the Identification of the Most Suitable Traits for Plant Functional Trait Analyses. *Oikos*, 117 (10):1533-1541
- Bihn, J.H.; Gebauer, G. & Brandl, R. 2010. Loss of functional diversity of ant assemblages in secondary tropical forests. *Ecology* 91:782-792.
- Borenstein, M.; Hedges, L.V.; Higgins, J.P. & Rothstein, H.R. 2010. A basic introduction to fixed-effect and random-effects models for meta-analysis. *Research Synthesis Methods*, 1(2):97-111.
- Brançalion, P.H.S.; Melo, F.P.L.; Tabarelli, M. & Rodrigues, R.R. 2013. Restoration Reserves as Biodiversity Safeguards in Human Modified Landscapes. *Brazilian Journal of Nature Conservation*, 11(2):1-5.

- Cadotte, M.W.; Carscadden, K. & Mirotchnick, N. 2011. Beyond species: Functional diversity and the maintenance of ecological processes and services. *Journal of Applied Ecology*, 48:1079-1087.
- Campos, M.M.S. 2009. *Ecofisiologia do uso de nitrogênio em espécies arbóreas da floresta ombrófila densa das terras baixas, Ubatuba, SP*. Dissertação de Mestrado. Instituto de Botânica IBT/SMA, São Paulo, 102 p.
- Carelli, M.L.C.; Fahl, J.I. 2006. Partitioning of nitrate reductase activity in *Coffea arabica* L. and its relation to carbon assimilation under different irradiance regimes. *Brazilian Journal of Plant Physiology*, 18:397-406.
- Cataldo, D.A.; Haroon, M.; Schrader, L.E. & Youngs, V.L. 1975. Rapid colorimetric determination of nitrate in plant tissue by nitration of salicylic acid. *Communications in Soil Science and Plant Analysis*, 6:71-80.
- Chave, J.; Coomes, D.; Jansen, S.; Lewis, S.L.; Swenson, N.G. et al. 2009. Towards a worldwide wood economics spectrum. *Ecology Letters*, 12: 351–366.
- Chazdon, R.L.; Letcher, S.G.; van Breugel, M.; Martínez-Ramos, M.; Bongers, F. & Finegan, B. 2007. Rates of change in tree communities of secondary Neotropical forests following major disturbances. *Philosophical Transactions of the Royal Society, B: Biological Sciences*, 362: 273–289.
- Chazdon R.L. 2008. Beyond deforestation: restoring forests and ecosystem services on degraded lands. *Science*, 320: 1458–1460.
- Chazdon, R.L.; Harvey, C.A.; Komar, O.; Griffith, D.M.; Ferguson, B.G.; Martínez-Ramos, M.; Morales, H.; Nigh, R.; Soto-Pinto, L.; van Breugel, M. & Philpott, S. M. 2009a. Beyond reserves: a research agenda for conserving biodiversity in human-modified tropical landscapes. *Biotropica* 41:142–153.
- Chazdon, R.L.; Peres, C.A.; Dent, D.; Sheil, D.; Lugo, A.E.; Lamb, D.; Stork, N.E. & Miller, S. 2009. The potential for species conservation in tropical secondary forests. *Conservation Biology*, 23:1406–1417.
- Chazdon, R. 2012. Regeneração de florestas tropicais. *Boletim do Museu Paraense Emílio Goeldi, Belém*, 7 (3): 195-218.
- Cheng, C.L.; Acedo, G.N.; Cristinsin, M. & Conkling, M.A. 1992. Sucrose mimics the light induction of *Arabidopsis* nitrate reductase gene transcription. *Proceedings of the National Academy of Sciences*, 89:1861-1864.

- CIIAGRO. 2006. Centro Integrado de Informações Agrometeorológicas Available in: <http://ciiagro.iac.sp.gov.br/>. Accessed in: September/2017;
- Cochran, W.G. 1954. The combination of estimates from different experiments. *Biometrics*, 10:101-129.
- Collinge, S.K. 1996. Ecological consequences of habitat fragmentation: implications for landscape architecture and planning. *Landscape and Urban Planning*, 36: 59-77.
- Cornelissen, J.H.C.; Lavorel, S.; Garnier, E.; Díaz, S.; Buchmann, N.; Gurvich, D.E.; Reich, P.B.; ter Steege, H.; Morgan, H.D.; v. d. Heijden, M.G.A.; Pausas, J.G. & Poorter, H. 2003. A handbook of protocols for standardised and easy measurement of plant functional traits worldwide. *Australian Journal of Botany*, 51:335-380.
- Couturier, J.; Doidy, J.; Guinet, F.; Wipf, D.; Blaudez, D. & Chalot, M. 2010. Glutamine, arginine and the amino acid transporter Pt-CAT11 play important roles during senescence in poplar. *Annals of Botany*, 105: 1159–1169.
- Dale, V.H. & Beyeler, S.C. 2001. Challenges in the development and use of ecological indicators. *Ecological Indicators* 1, 3–10.
- Davidson, E.A.; de Carvalho, C.J.R.; Figueira, A.M.; Ishida, F.Y.; Ometto, J.P.H.B.; Nardoto, G.B.; Sabá, R.T.; Hayashi, N.S.; Leal, E.C.; Vieria, I.C. et al. 2007. Recuperation of nitrogen cycling in Amazonian forests following agricultural abandonment. *Nature*, 447: 995—998.
- De Vries, F.T. & Bardgett, R.D. 2016. Plant community controls on short-term ecosystem nitrogen retention. *New Phytologist*, 210(3): 861–874.
- Díaz, S. & Cabido, M. 2001. Vive la difference: plant functional diversity matters to ecosystem processes. *Trends in Ecology and Evolution*, 16:646-655.
- Diaz, S.; Kattge, J.; Cornelissen, J.H.C. et al. 2016. The global spectrum of plant form and function. *Nature*, 14, 1–17.
- Durigan, G. & Ratter, J.A. 2006. Successional changes in Cerrado and Cerrado/Forest Ecotonal Vegetation in Western São Paulo State, Brazil, 1962–2000. *Edinburgh Journal of Botany*, 63 (1): 119–130.
- Egger, M.; Davey-Smith, G.; Schneider, M.; Minder, C. 1997. Bias in meta-analysis detected by a simple graphical test. *British Medical Journal*, 315:629-34.
- Egler, F.E. 1954. Vegetation science concepts I. Initial floristic composition, a factor in old-field vegetation development. *Vegetatio*, 4: 412–417.

- Epihov, D.Z.; Batterman, S.A.; Hedin, L.O.; Leake, J.R.; Smith, L.M. & Beerling D.J. 2017. N₂-fixing tropical legume evolution: a contributor to enhanced weathering through the Cenozoic? *Proceedings of the Royal Society B: Biological Sciences*, 284(1860).
- Erisman, J.W.; Sutton, M.A.; Galloway, J.; Klimont, Z. & Winiwarter W. 2008. How a century of ammonia synthesis changed the world. *Nature Geoscience* 1: 636–639. [10.1038/ngeo325](https://doi.org/10.1038/ngeo325)
- Farah, F.T.; Muylaert, R.L.; Ribeiro, M.C.; Ribeiro, J.W.; Manguiera, J.R.S.A; Souza, V.C.; Rodrigues, R.R. 2017. Integrating plant richness in forest patches can rescue overall biodiversity in human-modified landscapes. *Forest Ecology and Management*, 397: 78–88
- Farinaci, J.S.; Ferreira, L.C & Batistella, M. 2013. Forest Transition and Ecological Modernization: Eucalyptus Forestry Beyond Good And Bad. *Ambiente & Sociedade*, XVI (2): 25-44
- Fonseca, C.R. & Ganade, G. 2001. Species functional redundancy, random extinctions and the stability of ecosystems. *Journal of Ecology*, 89:118–125.
- Food and Agriculture Organization (FAO). 2010. *Global Forest Resources Assessment 2010*. FAO Forestry Paper 163.
- Food and Agriculture Organization (FAO). 2011. *State of the World's Forests 2009*, FAO, Rome, Italy.
- Foulkes, M.J.; Hawkesfor, M.J.; Barraclough, P.B.; Holdsworth, M.J.; Kerr S.; Kightley, S. & Shewry, P.R. 2009. Identifying traits to improve the nitrogen economy of wheat: Recent advances and future prospects. *Field Crops Research*, 114:329–342.
- Frak, E.; Millard, P.; Roux, X.L.; Guillaumie, S. & Wendler, R. 2002. Coupling Sap Flow Velocity and Amino Acid Concentrations as an Alternative Method to ¹⁵N Labeling for Quantifying Nitrogen Remobilization by Walnut Trees. *Plant Physiology*, 130.
- Fu, H.; Zhong, J.; Yuan, G.; Ni, L.; Xie, P. & Cao, T. 2014. Functional traits composition predict macrophytes community productivity along a water depth gradient in a freshwater lake. *Ecology and Evolution*, 4:1516–1523.
- Fundação SOS Mata Atlântica e Instituto de Pesquisas Espaciais (INPE). 2013. *Atlas dos remanescentes florestais da Mata Atlântica – período de 2011 a 2012*, São Paulo.
- Fundação SOS Mata Atlântica & Instituto Nacional de Pesquisas Espaciais (INPE). 2008. *Atlas dos Remanescentes Florestais da Mata Atlântica: Período 2000-2005*. Disponível em: <<http://mapas.sosma.org.br/>> Acesso em: 10 de jun. 2009

- Galloway, J.N.; Townsend, A.R.; Erisman, J.W.; Bekunda, M.; Cai, Z.; Freney, J.R.; Martinelli, L.A.; Seitzinger, S.P. & Sutton, M.A. 2008. Transformation of the Nitrogen Cycle: Recent Trends, Questions and Potential Solutions. *Science*, 320: 889-892.
- Galloway, J.N.; Dentener, F.J.; Capone, D.G.; Boyer, E.W.; Howarth, R.W.; Seitzinger, S.P.; Asner, G.P.; Cleveland, C.C.; Green, P.A.; Holland, E.A.; Karl, D.M.; Michaels, A.F.; Porter, P.A.; Townsend, A.R. & Smayda, C.J. 2004. Nitrogen cycles: past, present, and future. *Biogeochemistry*, 70: 153-226.
- Gandolfi, S.; Leitão Filho, H. & Bezerra, C.L.F. 1995. Levantamento Florístico e caráter sucessional das espécies arbustivo-arbóreas de uma Floresta Mesófila Semidecídua no município de Guarulhos, SP. *Revista Brasileira de Biologia* 55(4):753-767.
- Gardner, T.A.; Barlow, J.; Chazdon, R.; Ewers, R.M.; Harvey, C.A.; Peres, C.A. & Sodhi, N.S. 2009. Prospects for tropical forest biodiversity in a human-modified world. *Ecology Letters*, 12: 561–582.
- Garnier, E.; Shipley, B.; Roumet, C. & Laurent, G. 2001b. A standardized protocol for the determination of specific leaf area and leaf dry matter content. *Functional Ecology*, 15:688–695.
- Garnier, E.; Cortez, J.; Billes, G.; Navas, M.L.; Roumet, C.; Debussche, M.; Laurent, G.; Blanchard, A.; Aubry, D.; Bellmann, A.; Neil, C. & Toussaint, J.P. 2004. Plant functional markers capture ecosystem properties during secondary succession. *Ecology*, 85:2630-2637.
- Garten, C.T.; Huston, M.A.Jr. & Thoms, C.A. 1994. Topographic variation of soil nitrogen dynamics at Walker Branch Watershed Tennessee, *Forest Science*, 40:497 – 512.
- Gebauer, G.; Rehder, H. & Wollenweber, B. 1988. Nitrate, nitrate reduction and organic nitrogen in plants from different ecological and taxonomic groups of Central Europe. *Oecologia*, 75:371-385.
- Gómez-Pompa, A.G.; Vázquez-Yanes, C.N. 1981. Successional studies of a rain forest in Mexico, pp. 247-266. In: D. C. West, H. H. Schugart & D. B. Botkin (eds.), *Forest concepts and application*, Springer-Verlag, New York.
- Gough, L.; Osenberg, C.W.; Gross, K.L. & Collins, S.L. 2000. Fertilization effects on species density and primary productivity in herbaceous plant communities. *Oikos*, 89: 428–439.

- Griffith, D.M.; Quigley, K.M. & Anderson, T.M. 2016. Leaf thickness controls variation in leaf mass per area (LMA) among grazing-adapted grasses in Serengeti. *Oecologia*, 181 (4):1035–1040.
- Guariguata, M. R. & Dupuy, J. M., 1997. Forest regeneration in abandoned logging roads in lowland Costa Rica. *Biotropica*, 29: 15-28.
- Guariguata, M.R. & Ostertag, R. 2001. Neotropical secondary succession: changes in structural and functional characteristics. *Forest Ecology and Management*, 148:185-206.
- Grime, J.P. 1979. *Plant strategies and vegetation processes*. Chichester, UK: John Wiley & Sons.
- Gutschick, V.P. 1981. Evolved strategies in nitrogen acquisition by plants. *American Naturalist*, 11.
- Hammer, Ø.; Harper, D.A.T. & Ryan, P.D. 2001. PAST: Paleontological statistics software package for education and data analysis. *Palaeontologia Electronica*, 4(1): 9pp. http://palaeo-electronica.org/2001_1/past/issue1_01.htm
- Harrison, F. 2010. Getting started with meta-analysis. *Methods in Ecology & Evolution*, doi: 10.1111/j.2041-210X.2010.00056.x
- Higgins, J.P.T. & Thompson, S.G. 2002. Quantifying heterogeneity in a meta-analysis. *Statistics in Medicine*, 21(11):1539-1558.
- Higgins, J.P.T.; Thompson, S.G.; Deeks, J.J. & Altman, D.J. 2003 Measuring inconsistency in meta-analyses. *BMJ*, 327: 557-560.
- Hikosaka K. & Osone Y. 2009. A paradox of leaf-trait convergence: why is leaf nitrogen concentration higher in species with higher photosynthetic capacity? *Journal of Plant Research*, 122: 245-251.
- Hobbs, R.; Higgs, E. & Harris, J.A. 2009. 'Novel ecosystems: implications for conservation and restoration'. *Trends in Ecology & Evolution*, 24 (11):599-605.
- Hodge A, Robinson D, Fitter A. 2000. Are microorganisms more effective than plants at competing for nitrogen? *Trends in Plant Science* 5: 304–308.
- Högberg, P. 2012. What is the quantitative relation between nitrogen deposition and forest carbon sequestration? *Global Change Biology*, 18:1–2.
- Högborn, L.; Nilsson, U. & Örlander, G. 2002. Nitrate dynamics after clear felling monitored by in vivo nitrate reductase activity (NRA) and natural ¹⁵N abundance of *Deschampsia flexuosa* (L.). *Forest Ecology and Management*, 160:273–280.

- Holling, C.S. 1992. Cross-scale morphology, geometry, and dynamics of ecosystems. *Ecological Monographs*, 62:447–502.
- Hooper, D.U., Chapin, F.S., Ewel, J.J., Hector, A., Inchausti, P., Lavorel, S., Lawton, J.H., Lodge, D.M., Loreau, M., Naeem, S., Schmid, B., Setälä, H., Symstad, A.J., Vandermeer, J. & Wardle, D.A. 2005. Effects of biodiversity on ecosystem functioning: a consensus of current knowledge. *Ecological Monographs*, 75:3–35.
- Hope, G.D.; Prescott, C.E. & Blevins, L.L. 2003. Responses of available soil nitrogen and litter decomposition to openings of different sizes in dry interior Douglas-fir forests in British Columbia. *Forest, Ecology and Management*, 186: 33–46.
- Houlton, B.Z.; Sigman, D.M.; Schuur, E.A. & Hedin, L.O. 2007. A climate-driven switch in plant nitrogen acquisition within tropical forest communities. *Proceedings of the National Academy of Sciences*, 104(21): 8902 – 8906.
- IBGE. 2001. Instituto Brasileiro de Geografia e Estatística. Mapa de Solos do Brasil - escala 1:5.000.000
- Idol, T.W.; Pope, P.E. & Ponder Jr., F. 2003. N mineralization, nitrification, and N uptake across a 100-year chronosequence of upland hardwood forests. *Forest, Ecology and Management*, 176: 509–518
- Jerabkova, L.; Prescott, C. & Kishchuk, B.E. 2006. Effect of variable-retention harvesting on soil nitrogen availability in boreal mixed forests. *Canadian Journal of Forest Research*, 36: 3029–3038.
- Jiang, Z.C. & Hull, R.J. 2000. Diurnal patterns of nitrate assimilation in Kentucky bluegrass. *Journal of Plant Nutrition*, 23:443–456.
- Joly, C.A. & Barlow, J. 2016. 3º Relatório do Projeto Temático NERC & BIOTA ECOFOR Biodiversity and Ecosystem Functioning in Degraded and Recovering Amazonian and Atlantic Forests (FAPESP-RCUK).
- Joly, C.A.; Metzger, J.P. & Tabarelli, M. 2014. Experiences from the Brazilian Atlantic Forest: ecological findings and conservation initiatives. *New Phytologist*. Tansley Review - doi: 10.1111/nph.12989
- Joly, C.A.; Assis, M.A.; Bernacci, L.C.; Tamashiro, J.Y. et al. 2012. Florística e fitossociologia em parcelas permanentes da Mata Atlântica do sudeste do Brasil ao longo de um gradiente altitudinal. *Biota Neotropica*, 12 (1): 123-145.
- Joly, C.A.; Aïdar, M.P.M.; Klink, C.A.; Mcgrath, D.G.; Moreira, A.G.; Moutinho, P.; Nepstad, D.C.; Oliveira, A.A.; Pott, A.; Rodal, M.J.N. & Sampaio, E.V.S.B. 1999.

- Evolution of the Brazilian phytogeography classification systems: implications for biodiversity conservation. *Ciência e Cultura*, 51(5/6): 331-348.
- Kattge, J.; Diaz, S.; Lavorel, S.; Prentice, I.C.; et al. 2011. TRY - a global database of plant traits. *Global Change Biology*, 17:2905-2935.
- Keddy, P.A. 1992. Assembly and response rules: two goals for predictive community ecology. *Journal of Vegetation Science*, 3:157–164.
- Keenan, T.F. & Níinemets, U. 2016. Global leaf trait estimates biased due to plasticity in the shade, *Nature plants*, 3, 16201.
- Keeney, D.R. 1980. Prediction of soil nitrogen availability in forest ecosystems: a literature review. *Forest Science*, 26:159-171.
- Kerkhoff, A.J. & Enquist, B.J. 2006. Ecosystem allometry: the scaling of nutrient stocks and primary productivity across plant communities. *Ecology Letters*, 9:419–427.
- Killingbeck, K.T. 1986. The terminology jungle revisited: making a case for use of the term resorption. *Oikos*, 46:263-264.
- Kitajima, K. & Poorter, L. 2010. Tissue-level leaf toughness, but not lamina thickness, predicts sapling leaf lifespan and shade tolerance of tropical tree species. *New Phytologist*, 186: 708–721.
- Kobe, R.K.; Coates, K.D. 1997. Models of sapling mortality as a function of growth to characterize interspecific variation in shade tolerance of eight tree species of northwestern British Columbia. *Canadian Journal of Forest Research*, 27:227–236.
- Köppen, W. 1948. *Climatologia: con un estudio de los climas de la tierra*. México: Fondo de Cultura Economica, 478p.
- Koyama, L. & Tokuchi, N. 2003. Effects of NO₃⁻ availability on NO₃⁻ use in seedlings of three woody shrub species. *Tree Physiology*, 23:281–288.
- Kraiser, T.; Gras, D.E.; Gutiérrez, A.G.; González, B. & Gutiérrez, R.A. 2011. A holistic view of nitrogen acquisition in plants. *Journal of Experimental Botany*, 62 (4): 1455–1466.
- Laliberté, E.; Wells, J.A.; Declerck, F.; Metcalfe, D.J.; Catterall, C.P. et al. 2010. Land-use intensification reduces functional redundancy and response diversity in plant communities. *Ecology Letters*, 13: 76-86.
- Lamb, D. 1980. Soil nitrogen mineralisation in a secondary rainforest succession. *Oecologia*, 47:257-263.

- Laurence, W.F. & Bierregaard, R.O.Jr. 1997. *Tropical Forest Remnants: Ecology, Management, and Conservation of Fragmented Communities*. Chicago: The University of Chicago, 616 p.
- Laurance, W.F.; Delamônica, P.; Laurance, S.G.; Vasconcelos, H.L. & Lovejoy, T.E. 2000. Rainforest fragmentation kills big trees. *Nature*, 404: 836.
- Laurance, W.L.; Albernaz, A.K.M.; Fearnside, P.M.; Vasconcelos, H.; Ferreira, L.V. "Deforestation in Amazonia". 2004. *Science*, 304:1109-1111.
- Lavorel, S.; McIntyre, S.; Landsberg, J. & Forbes, D. 1997. Plant functional classifications: from general groups to specific groups based on response to disturbance. *Trends in Ecology and Evolution*, 12:474–478
- Lavorel, S & Garnier, E. 2002. Predicting changes in community composition and ecosystem functioning from plant traits-revisiting the Holy Grail. *Functional Ecology*, 16: 545-556.
- Lavorel, S.; Grigulis, K.; McIntyre, S.; Williams, N.S.G.; Garden, D.; Dorrough, J.; Berman, S.; Quétier, F.; Thébault, A. & Bonis, A. 2007. Assessing functional diversity in the field – methodology matters! *Functional Ecology*, 22:134-147.
- Lea, P.J. & Mifflin, B.J. 2003. Glutamate synthase and the synthesis of glutamate in plants. *Plant Physiology and Biochemistry*, 41:555-564.
- Lebrija-Trejos, E.; Pérez-García, E.; Meave, J.A.; Bongers, F. & Poorter, L. 2010b. Functional traits and environmental filtering drive community assembly in a species-rich tropical system. *Ecology*, 91:386–398.
- Lebrija-Trejos, E.; Pérez-García, E.A.; Meave, J.A.; Poorter, L. & Bongers, F. 2011. Environmental changes during secondary succession in a tropical dry forest in Mexico. *Journal of Tropical Ecology*, 27: 477–489.
- Lensi, R.; Clay-Josserand, A. & Jocteur Monrozier, L. 1995. Denitrifiers and denitrifying activity in size fractions of a mollisol under permanent pasture or continuous cultivation. *Soil Biology & Biochemistry*, 27, 61–69.
- Lepš, J.; de Bello, F.; Lavorel, S. & Berman, S. 2006. Quantifying and interpreting functional diversity of natural communities: practical considerations matter. *Preslia*, 78: 481–50.
- Li, W.; Cheng, J.M.; Yu, K.L.; Epstein, H.E.; Guo, L.; Jing, G.H.; et al. 2015. Plant functional diversity can be independent of species diversity: Observations based on the impact of 4-yr of nitrogen and phosphorus additions in an alpine meadow. *PLoS ONE*, 10, e0136040.

- Liu, J.; Dietz, T.; Carpenter, S.R.; Alberti, M.; Folke, C.; Moran, E. et al. 2007. Complexity of coupled human and natural systems. *Science*, 317: 1513–1516.
- Liu, Q.; Chen, X; Wu, K & Fu, X. 2015. Nitrogen signaling and use efficiency in plants: what's new? *Current Opinion in Plant Biology*, 27:192–198.
- Liu, W. & Su, J. 2017. Successional leaf traits of monsoon evergreen broad-leaved forest, Southwest China. *iForest*, 10: 391-396.
- Lipson, D. & Näsholm, T. 2001. The unexpected versatility of plants: organic nitrogen use and availability in terrestrial ecosystems. *Oecologia*, 128: 305–316.
- Lloyd, J.; Bloomfield, K.; Domingues, T.F. & Farquhar, G.D. 2013. Photosynthetically relevant foliar traits correlating better on a mass vs an area basis: of ecophysiological relevance or just a case of mathematical imperatives and statistical quicksand? *New Phytologist*, 199: 311–32.
- Lodhi, M.A.K. & Ruess, R.W. 1988. Variation in soil nitrifiers and leaf nitrate reductase activity of selected tree species in a forest community. *Soil Biology & Biochemistry*, 20 (6): 939-943.
- Lohbeck, M.; Poorter, L.; Paz, H.; Pla, L.; van Breugel, M.; Martínez-Ramos, M. & Bongers, F. 2012. Functional diversity changes during tropical forest succession. *Perspectives in Plant Ecology, Evolution and Systematics*, 14:89–96.
- Lohbeck, M.; Poorter, L.; Lebrija-Trejos, E.; Martínez-Ramos, M.; Meave, J.A.; Paz, H. et al. 2013. Successional changes in functional composition contrast for dry and wet tropical forest. *Ecology*, 94: 1211–1216.
- Lohbeck, M.; Lebrija-Trejos, E.; Martínez-Ramos, M.; Meave, J.A.; Poorter, L; et al. 2015. Functional Trait Strategies of Trees in Dry and Wet Tropical Forests Are Similar but Differ in Their Consequences for Succession. *PLOS ONE* 10(4): e0123741. <https://doi.org/10.1371/journal.pone.0123741>
- MA. 2005. Millennium Ecosystems Assessment. World Resources Institute, Washington DC, USA.
- Maathuis, F. 2009. Physiological functions of mineral nutrients. *Current Opinion in Plant Biology* 12: 250–258.
- Maggs, J. 1991. Nitrogen mineralization and nitrification in rain- forests of contrasting nutrient status and physiognomic structure, near Lake Eacham, northeast Queensland. *Australian Journal of Ecology*, 16:47–51.

- Maithani, K.; Arunachalam, A.; Tripathi, R.S. & Pandey, H.N. 1998. Nitrogen mineralization as influenced by climate, soil and vegetation in a subtropical humid forest in northeast India. *Forest, Ecology and Management*, 109:91–101.
- Malhado, A.C.M.; Malhi, Y.; Whittaker, R.J.; Ladle, R.J.; ter Steege, H. et al. 2009. Spatial trends in leaf size of Amazonian rainforest trees. *Biogeosciences*, 6: 1563–1576.
- Malhi, Y.; Gardner, T.A.; Goldsmith, G.R.; Silman, M.R. & Zelazowski, P. 2014. Tropical forests in the Anthropocene. *Annual Review of Environment and Resources*, 39:125–159.
- Marchiori, N.M. 2012. Aspectos funcionais da Floresta Ombrófila Densa Montana, Parque Estadual Serra do Mar: estrutura, biomassa aérea, uso de nitrogênio e fotossíntese. Dissertação de Mestrado. Universidade Estadual de Campinas, Campinas. 112p.
- Marschner, H. 1995. Mineral nutrition of higher plants. London: Academic Press, 889 pp.
- Marrs, R.H., Proctor, J., Heaney, A. & Mountford, M.D. 1988. Changes in soil nitrogen-mineralization and nitrification along an altitudinal transect in tropical rain-forest in Costa Rica. *Journal of Ecology*, 76:466–482.
- Martins, S.C. 2010. Caracterização dos solos e serapilheira ao longo do gradiente altitudinal da Mata Atlântica, estado de São Paulo. Tese de Doutorado. Centro de Energia Nuclear na Agricultura, Universidade de São Paulo, Piracicaba, SP.
- Masclaux-Daubresse, C.; Daniel-Vedele, F.; Dechorgnat, J.; Chardon, F.; Gaufichon, L. & Suzuki, A. 2010. Nitrogen uptake, assimilation and remobilization in plants: challenges for sustainable and productive agriculture. *Annals of Botany*, 105: 1141–1157. doi: 10.1093/aob/mcq028
- Mason, N.W.H.; Mouillot, D.; Lee, W.G. & Wilson, J.B. 2005. Functional richness, functional evenness and functional divergence: the primary components of functional diversity. *Oikos*, 111:112-118.
- Matson, P.A.; Vitousek, P.M.; Ewel, J.J. & Mazzarino, M.J. 1987. Nitrogen transformations following tropical forest felling and burning on a volcanic soil. *Ecology*, 68: 491–502.
- Mayfield, M.M., Boni, M.E., Daily, G.C. & Ackerly, D. 2005. Species and functional diversity of native and human-dominated plant communities. *Ecology*, 86, 2365–2372.
- Mazin, S.C. & Martinez, E.Z. 2009. Modelos Estatísticos em Metanálises. Available in: http://rms.fmrp.usp.br/upload/file/livro_revisado.pdf
- McGill, B.; Enquist, B.; Weiher, E. & Westoby, M. 2006. Rebuilding community ecology from functional traits. *Trends in Ecology & Evolution*, 21:178-185.

- McKey D. 1994 Legumes and nitrogen: the evolutionary ecology of a nitrogen-demanding lifestyle. In *Advances in legume systematics: part 5. The nitrogen factor* (eds JI Sprent, D McKey), pp. 211– 228. Kew, UK: Royal Botanic Gardens.
- Melo, F.P.; Arroyo-Rodríguez, V.; Fahrig, L.; Martinez-Ramos, M. & Tabarelli, M. 2013a. On the hope for biodiversity-friendly tropical landscapes. *Trends in Ecology & Evolution*, 28(8):462–468
- Melo, F.P.L.; Pinto, S.R.R.; Bracalioni, P.H.S.; Castro, O.S.; Rodrigues, R.R.; Aronson, J. & Tabarelli, M. 2013b. Priority setting for scaling-up tropical forest restoration projects: early lessons from the Atlantic Forest Restoration Pact. *Environmental Science and Policy*, 33: 395–404.
- Melzer, E. & O'Leary, M.H. 1987. Anaplerotic CO₂ fixation by phosphoenolpyruvate carboxylase in C₃ plants. *Plant Physiology*, 84:58–60
- Mesquita, R.C.G.; Delamonica, P. & Laurence, W.F. 1999. Effect of surrounding vegetation on edge-related tree mortality in Amazonian Forest fragments. *Biological Conservation*, 91:129-134.
- Messier, J.; Lechowicz, M.J.; McGill, B.J.; Violle, C. & Enquist, B.J. 2017. Interspecific integration of trait dimensions at local scales: the plant phenotype as an integrated network. *Journal of Ecology* doi: 10.1111/1365-2745.12755
- Micallef, B.J. & Shelp, B.J. 1989. Arginine metabolism in developing soybean cotyledons I - Relationship to nitrogen nutrition. *Plant Physiology*, 90: 624-630.
- Ministério do Meio Ambiente – MMA. 2010. *Mata Atlântica: manual de adequação ambiental / Maura Campanili e Wigold Bertoldo Schaffer*. – Brasília: MMA/SBF, 2010. 96 p. ; il. color. : 29cm. (Série Biodiversidade, 35)
- Mouchet, M.A.; Vileger, S.; Mason, N.W.H. & Mouillot, D. 2010. Functional diversity measures: an overview of their redundancy and their ability to discriminate community assembly rules. *Functional Ecology*, 24:867–876.
- Morena, M. 2015. *Ecofisiologia do uso de nitrogênio em espécies arbóreas da Floresta Ombrófila Mista, Parque Estadual de Campos do Jordão, SP*. Dissertação de mestrado, Programa de Pós-graduação em Biodiversidade e Meio Ambiente, Instituto de Botânica, São Paulo. 70p.
- Mueller, C.; Torres, M. & Morais, M. 1997. *Referencial básico para a construção de um sistema de indicadores urbanos*. Brasília: Instituto de Pesquisa Econômica Aplicada (IPEA).

- Murcia, C. 1995. Edge effects in fragmented forests: implications for conservation. *Tree*, 10 (2):58-62.
- Myers, N.; Mittermeier, R.A.; Mittermeier, C.G.; Fonseca, G.A.B. & Kent, J. 2000. Biodiversity hotspots for conservation priorities. *Nature*, 403: 853-858.
- Naeem, S. & Wright, J.P. 2003. Disentangling biodiversity effects on ecosystem functioning: deriving solutions to a seemingly insurmountable problem. *Ecology Letters*, 6:567-579.
- Näsholm, T.; Ekblad, A.; Nordin, A.; Giesler, R.; Hogberg, M. & Högberg, P. 1998. Boreal forest plants take up organic nitrogen. *Nature*, 392:914–916.
- Niemi, G.J. & McDonald, M.E. 2004. Application of Ecological Indicators. *Annual Review of Ecology, Evolution, and Systematics*, 35:89-111
- Niinemets, U. 1999. Components of leaf dry mass per area - thickness and density - alter leaf photosynthetic capacity in reverse directions in woody plants. *New Phytologist*, 144: 35–47.
- Niinemets, Ü. 2001. Global-scale climatic controls of leaf dry mass per area, density, and thickness in trees and shrubs. *Ecology*, 82:453-469.
- Nock, C.A.; Vogt, R.J.; Beisner, B.E. 2016. Functional Traits. In: eLS. John Wiley & Sons, Ltd: Chichester. DOI: 10.1002/9780470015902.a0026282
- Norden, N.; Chazdon, R.L.; Chao, A.; Jiang, Y.H. & Vilchez-Alvarado, B. 2009. Resilience of tropical rain forests: tree community reassembly in secondary forests. *Ecology Letters*, 12:385–394.
- Norden, N.; Angarita, H. A.; Bongers, F.; Martínez-Ramos, M.; Granzow-de la Cerda, I.; van Breugel, M.; Lebrija-Trejos, E.; Meave, J.A.; Vandermeer, J.; Williamson, G.B.; Finegan, B.; Mesquita, R. & Chazdon, R. L. 2015. Successional dynamics in Neotropical forests are as uncertain as they are predictable. *Proceedings of the National Academy of Sciences of the United States of America*, 112: 8013–8018
- Norisada, M. & Kojima, K. 2005. Nitrogen form preference of six dipterocarp species. *Forest Ecology and Management*, 216: 175–186.
- Noss, R.F. 1999. Assessing and monitoring forest biodiversity: a suggested framework and indicators. *Forest Ecology and Management*, 115:135-146.
- Nunes-Nesi, A.; Fernie, A.R. & Stitt, M. 2010. Metabolic and Signaling Aspects Underpinning the Regulation of Plant Carbon Nitrogen Interactions. *Molecular Plant*, 3(6): 973–996.

- Okumoto, S. & Pilot, G. 2011. Amino Acid Export in Plants: A Missing Link in Nitrogen Cycling. *Molecular Plant*, 4(3):453–463.
- Oliveira, H.C.; da Silva, L.M.; de Freitas, L.D.; Debiassi, T.V.; Marchiori, N.M.; Aidar, M.P.; Bianchini, E.; Pimenta, J.A. & Stolf-Moreira, R. 2017. Nitrogen use strategies of seedlings from neotropical tree species of distinct successional groups. *Plant Physiology and Biochemistry*, 114: 119-127
- Oliveira-Filho, A.T. & Fontes, M.L.P. 2000. Patterns of floristic differentiation among Atlantic Forests in southeastern Brasil and the influence of climate. *Biotropica* 32:793-810.
- Olsson, M.O. & Falkengren-Grerup, U. 2003. Partitioning of nitrate uptake between trees and understory in oak forests. *Forest Ecology and Management*, 179:311-320.
- Orebamjo, T.O. & Stewart, G.H. 1975. Ammonium inactivation of nitrate reductase in *Lemna minor* L. *Planta*, 122:37-44.
- Padgurschi, M.C.G.; Pereira, L.S., Tamashiro, J.Y. & Joly, C.A. 2011. Composição e similaridade florística entre duas áreas de Floresta Atlântica Montana, São Paulo, Brasil. *Biota Neotropica*, 11(2):00-00.
- Paungfoo-Lonhienne, C.; Lonhienne, T.G.; Rentsch, D.; Robinson, N.; Christie, M.; Webb, R.I.; Gamage, H.K.; Carroll, B.J.; Schenk, P.M. & Schmidt, S. 2008. Plants can use protein as a nitrogen source without assistance from other organisms. *Proceedings of the National Academy of Sciences*, 105: 4524–4529.
- Pate, J.S. 1980. Transport and partitioning of nitrogenous solutes, *Annual Review of Plant Physiology*, 31: 313–340;
- Peoples, M.B. & Gifford, R.M. 1997. Regulation of the transport of nitrogen and carbon in higher plants. *In* DT Dennis, DB Layzell, DD Lefebvre, DH Turpin, eds, *Plant Metabolism*, Ed 2. Addison Wesley Longman, Essex, UK, pp 525–538
- Pereira-Silva, E.F.L. 2008. Estratégias ecofisiológicas no uso de nitrogênio em espécies arbóreas de floresta ombrófila densa submontana e estacional semidecidual, SP. Tese de Doutorado. Universidade Estadual de Campinas, Campinas – SP, 217p.
- Pérez, C.A.; Carmona, M.R.; Fariña, J.M. & Armesto, J.J. Selective logging of lowland evergreen rainforests in Chiloe´ Island, Chile: Effects of changing tree species composition on soil nitrogen transformations. *Forest Ecology and Management*, 258 (2009): 1660–1668.

- Pérez-Harguindeguy, N.; Díaz, S.; Garnier, E.; Lavorel, S.; Poorter, H.; Jaureguiberry, P.; Bret-Harte, M.S.; Cornwell, W.K.; Craine, J.M.; Gurvich, D.E.; Urcelay, C.; Veneklaas, E.J. et al. 2013. New handbook for standardised measurement of plant functional traits worldwide. *Australian Journal of Botany*, 61:167-234.
- Pérez-Ramos, I.; Roumet, C.; Cruz, P.; Blanchard, A.; Autran, P. & Garnier, E. 2012. Evidence for a 'plant community economics spectrum' driven by nutrient and water limitations in a Mediterranean rangeland of southern France. *Journal of Ecology*, 100: 1315–1327
- Petchey, O.L.; Hector, A. & Gaston, K.J. 2004. How do different measures of functional diversity perform? *Ecology*, 85 (3): 847–857.
- Petchey, O.L. & Gaston, K.J. 2006. Functional diversity: back to basics and looking forward. *Ecology Letters*, 9:741-758.
- Pillar, V.D., Blanco, C.C., Müller, S.C., et al. 2013. Functional redundancy and stability in plant communities. *Journal of Vegetation Science*, 24: 963–974.
- Pistorius, E.; Gewitz, H-S.; Voss, H. & Vennesland, B. 1976. Reversible inactivation of nitrate reductase in *Chlorella vulgaris* in vivo. *Planta*, 128:73-80
- Poorter, H. & Garnier, E. 1999. The ecological significance of variation in relative growth rate and its components. Pages 81–120 in F. Pugnaire and F. Valladares, editors. *Handbook of functional plant ecology*. Marcel Dekker, New York, New York, USA.
- Poorter, L. & Markesteijn, L. 2008. Seedling traits determine drought tolerance of tropical tree species. *Biotropica*, 40: 321–331.
- Poorter, L.; Paz, H.; Wright, S.J.; Ackerly, D.D.; Condit, R.; et al. 2008b. Are functional traits good predictors of demographic rates? Evidence from 5 neotropical forests. *Ecology*, 89: 1908–1920.
- Poorter, H. & Jong, R. 1999. A comparison of specific leaf area, chemical composition and leaf construction costs of field plants from 15 habitats differing in productivity. *New Phytologist*, 143:163–176.
- Poorter, H.; Niinemets, U.; Poorter, L.; Wright, J.I. & Villar, R. 2009. Causes and consequences of variation in leaf mass per area (LMA): a meta-analysis. *New Phytologist*, 182: 565–588
- Poorter, L.; McDonald, I.; Alarcón, A.; Fichtler, E.; Licona, J.C.; Peña-Claros, M.; Sterck, F. Villegas, Z. & Sass-Klaassen, U. 2010. The importance of wood traits and hydraulic

- conductance for the performance and life history strategies of 42 rainforest tree species. *New Phytologist*, 185: 481–492
- Prado Junior, J.; Schiavini, I.; Vale, V.; Lopes, S.; Arantes, C. & Oliveira, A.P. 2015. Functional leaf traits of understory species: strategies to different disturbance severities. *Brazilian Journal of Biology*, 75 (2): 339-346.
- Preston, K.A.; Cornwell, W.K. & DeNoyer, J.L. 2006. Wood density and vessel traits as distinct correlates of ecological strategy in 51 California coast range angiosperms. *New Phytologist*, 170: 807–818.
- Purschke, O.; Schmid, B.C.; Sykes, M.T.; Poschlod, P.; Michalski, S.G.; Durka, W.; Kühn, I.; Winter, M. & Prentice, H.C. 2013. Contrasting changes in taxonomic, phylogenetic and functional diversity during a long-term succession: Insights into assembly processes. *Journal of Ecology*, 101:857–866.
- Pütz, S.; Groeneveld, J.; Alves, L.F.; Metzger, J.P. & Huth A. 2011. Fragmentation drives tropical forest fragments to early successional states: A modelling study for Brazilian Atlantic forests. *Ecological Modelling*, 222:1986-1997.
- R Development Core Team. 2011. R: A language and environment for statistical computing. R Foundation for Statistical Computing, Vienna, Austria. ISBN 3-900051-07-0, URL <http://www.R-project.org/>
- Ramos, C. 1996. Effect of agricultural practices on the nitrogen losses in the environment. In: Rodriguez-Barrueco C, ed., *Fertilizers and Environment*. Kluwer Academic Publishers, Dordrecht, The Netherlands.
- Raven, J.A. & Andrews, M. 2010. Evolution of tree nutrition. *Tree Physiology*, 30:1050-1071.
- Reich, P.B.; Walters, M.B. & Ellsworth, D.S. 1994. Photosynthesis-nitrogen relations in Amazonian tree species. I. Patterns among species and communities. *Oecologia*, 97:62–72.
- Reich, P.B.; Walters, M.B. & Ellsworth, D.S. 1997. From tropics to tundra: global convergence in plant functioning. *Proceedings of the National Academy of Sciences of the United States of America*, 94:13730–13734.
- Reich, P.B.; Ellsworth, D.S. & Walters, M.B. 1998. Leaf structure (specific leaf area) modulates photosynthesis and nitrogen relations: evidence from within and across species and functional groups. *Functional Ecology*, 12: 948–958.

- Reich, P.B.; Wright, I.J.; Cavender-Bares, J.; Craine, J.M.; Oleksyn, J.; Westoby, M. & Walters, M.B. 2003. The evolution of plant functional variation: Traits, spectra, and strategies. *International Journal of Plant Sciences*, 164 (S3): S143-S164.
- Reich, P.B. 2014. The world-wide ‘fast-slow’ plant economics spectrum: a traits manifesto. *Journal of Ecology* 102: 275–301.
- Rennenberg, H, & Schmidt, S. 2010. Perennial lifestyle--an adaptation to nutrient limitation? *Tree Physiology*, 30(9):1047-9.
- Reynolds, P.E.; Thevathasan, N.V.; Simpson, J.; Gordon, A.; Lautenschlager, A.M.; Bell, R.A.; Gresch, W.F. & Buckley, D.A. 2000. Alternative forest release treatments affect microclimate and soil nitrogen mineralization. *Forest Ecology and Management* 133: 115–125.
- Ribeiro, M.C.; Metzger, J.P.; Martensen, A.C.; Ponzoni, F.J. & Hirota, M.M. 2009. The Brazilian Atlantic Forest: How much is left, and how is the remaining forest distributed? Implications for conservation. *Biological Conservation*, 142:1141-1153.
- Ribeiro, S.L.C. 2013. Economia do nitrogênio em árvores tropicais. Tese (doutorado) – Universidade Estadual de Campinas, Instituto de Biologia. 205 p.
- Rice, E.L. & Panchoy, S.K. 1972. Inhibition of Nitrification by Climax Ecosystems. *American Journal of Botany*, 59 (10):1033-1040.
- Richardson, S.J.; Allen, R.B.; Buxton, R.P.; Easdale, T.A.; Hurst, J.M.; Morse, C.W.; Smissen, R.D. & Peltzer, D.A. 2013. Intraspecific Relationships among Wood Density, Leaf Structural Traits and Environment in Four Co-Occurring Species of *Nothofagus* in New Zealand. *Plos One*, 8(3):58878
- Robbink, R.; Hornung, M. & Roelofs, J.G.M. 1998. The effects of air-borne nitrogen pollutants on species diversity in natural and semi-natural European vegetation. *Journal of Ecology*, 86: 717–738.
- Robertson, G.P.; Vitousek, P.M. 1981. Nitrification potentials in primary and secondary succession. *Ecology*, 62:376:386.
- Roscher, C.; Schumacher, J.; Gubsch, M.; Lipowsky, A.; Weigelt, A. Buchmann, N. et al. 2012. Using plant functional traits to explain diversity-productivity relationships. *PLoS ONE*, 7:e36760.
- Rothstein, D.E.; Zak, D.R. & Pregitzer, K.S. 1996. Nitrate deposition in northern hardwood forests and the nitrogen metabolism of *Acer saccharum marsh*. *Oecologia*, 108: 338–344.

- Roycewicz, P. & Malamy, J.E. 2012. Dissecting the effects of nitrate, sucrose and osmotic potential on *Arabidopsis* root and shoot system growth in laboratory assays. *Philosophical Transactions of the Royal Society B: Biological Sciences*, 367:1489–1500.
- Rowland, L.; Lobo-do-Vale, R.L.; Christoffersen, B.O.; Melem, E.A.; Kruijt, B.; Vasconcelos, S.S.; Domingues, T.F.; Binks, O.J.; Oliveira, A.A.R.; Metcalfe, D.B. et al. 2015. After more than a decade of soil moisture deficit, tropical rainforest trees maintain photosynthetic capacity, despite increased leaf respiration. *Global Change Biology*, 21: 4662–4672.
- Rowland, L.; Zaragoza-Castells, J.; Bloomfield, K.J.; Turnbull, M.H.; Bonal, D.; Burban, B.; Salinas, N.; Cosio, E.; Metcalfe, D.J.; Ford, A. et al. 2017. Scaling leaf respiration with nitrogen and phosphorus in tropical forests across two continents. *New Phytologist*, 214: 1064–1077
- Russo, S.E; Kochsiek, A.; Olney, J.; Thompson, L.; Miller, A.E. & Tan, S. 2013. Nitrogen uptake strategies of edaphically specialized Bornean tree species. *Plant Ecology*, 214:1405–1416.
- Santiago, L.S.; Goldstein, G.; Meinzer, F.C.; Fisher, J.B. Machado, K. et al. 2004. Leaf photosynthetic traits scale with hydraulic conductivity and wood density in Panamanian forest canopy trees. *Oecologia*, 140: 543–550.
- Santos, B.A.; Peres, C.A.; Oliveira, M.A.; Grillo, A.; Alves-Costa; C.P. & Tabarelli, M. 2008. Drastic erosion in functional attributes of tree assemblages in Atlantic forest fragments of northeastern Brazil. *Biological Conservation*, 141: 249-260.
- Sapijanskas, J. & Loreau, M. 2010. Cascading extinctions, functional complementarity, and selection in two-trophic-level model communities: A trait-based mechanistic approach. *Journal of Theoretical Biology*, 267:375-387.
- Schimann, H.; Ponton, S.; Hättenschwiler, S.; Ferry, B.; Lensi, R.; Domenach, A.M & Roggy, J.C. 2008. Differing nitrogen use strategies of two tropical rainforest late 15 successional tree species in French Guiana: Evidence from N natural abundance and microbial activities. *Soil Biology & Biochemistry*, 40:487–494.
- Schmidt, S. & Stewart, G.R. 1998. Transport, storage and mobilization of nitrogen by trees and shrubs in the wet/dry tropics of northern Australia. *Tree Physiology*, 18:403-410.
- Schmitt, C.B.; Belokurov, A.; Besancon, C.; Boisrobert, L.; Burgess, N.D.; Campbell, A.; Coad, L., Fish, L.; Gliddon, D.; Humphries, K.; Kapos, V.; Loucks, C.; Lysenko, I;

- Miles, L.; Mills, C.; Minnemeyer, S.; Pistorius, T.; Ravilious, C.; Steininger, M. & Winkel, G. 2009. Global Ecological Forest Classification and Forest Protected Area Gap Analysis. Analyses and recommendations in view of the 10% target for forest protection under the Convention on Biological Diversity (CBD). 2nd revised edition. Freiburg University Press, Freiburg, Germany
- Shepherd, G. J. Fitopac 2.1. 2010. Manual do usuário. Campinas: UNICAMP.
- Shipley, B.; Lechowicz, M.J.; Wright, I. & Reich, P.B. 2006. Fundamental trade-offs generating the worldwide leaf economics spectrum. *Ecology*, 87: 535–541.
- Siche, R.; Agostinho, F.; Ortega, E. & Romeiro, A. 2007. Índices versus indicadores: precisões conceituais na discussão da sustentabilidade de países. *Ambiente & Sociedade*, X (2):137-148
- Siddique, I.; Engel, V.L.; Parrotta, J.A.; Lamb, D.; Nardoto, G.B.; Ometto, J.P.H.B.; Martinelli, L.A. & Schmidt, S. 2008. Dominance of legume trees alters nutrient relations in mixed species forest restoration plantings within seven years. *Biogeochemistry*, 88:89–101.
- Siebenkas, A. & Roscher C. 2016. Functional composition rather than species richness determines root characteristics of experimental grasslands grown at different light and nutrient availability. *Plant and Soil*, 404:399–412.
- Siegloch, A.E.; Froehlich, C.G & Spies, M.R. 2012. Diversity of Ephemeroptera (Insecta) of the Serra da Mantiqueira and Serra do Mar, southeastern Brazil. *Revista Brasileira de Entomologia*, 56(4):473–480.
- Silva, J.G. 2012. Ecofisiologia do uso de nitrogênio em espécies arbóreas da Floresta Ombrófila Densa, Caraguatatuba, SP. Dissertação (Mestrado) -- Instituto de Botânica da Secretaria de Estado do Meio Ambiente, 103p. il.
- Silva, R. F. B. et al. 2017. Socioeconomic changes and environmental policies as dimensions of regional land transitions in the Atlantic Forest, Brazil. *Environmental Science & Policy*. 74: 14-22.
- Silver, W.L.; Neff, J.; McGroddy, M.; Veldkamp, E.; Keller, M. & Cosme, R., 2000. Effects of soil texture on belowground carbon. *Ecosystems*, 3:193–209.
- Slocum, R.D. 2005. Genes, enzymes and regulation of arginine biosynthesis in plants. *Plant Physiology and Biochemistry*, 43:729–745.

- Smith, C.K.; Gholz, J.L. & Oliveira, F.D.A. 1998. Soil nitrogen dynamics and plant-induced soil changes under plantations and primary forest in lowland Amazonia, Brazil. *Plant Soil*, 200: 193–204.
- Smirnoff, N.; Todd, P.; Stewart, G.R. 1984. The Occurrence of Nitrate Reduction in the Leaves of Woody Plants. *Annals of Botany* 54, 363-374.
- Smirnoff, N. & Stewart, G.R. 1985. Nitrate assimilation and translocation by higher plants: Comparative physiology and ecological consequences. *Plant Physiology*, 64:133-140.
- Song, J; Ding, X; Feng, G & Zhang, F. 2006. Nutritional and osmotic roles of nitrate in a euhalophyte and a xerophyte in saline conditions. *New Phytologist*, 171 (2): 357-366.
- Sousa, M.R. & Ribeiro, A.L.P. 2009. Revisão sistemática e meta-análise de estudos de diagnóstico e prognóstico: um tutorial. *Arquivos Brasileiro de Cardiologia*, 92 (3)
- Souza, B.C.; Oliveira, R.S.; Araújo, F.S.; Lima, A.L.A. & Rodal, M.J.N. 2015. Divergências funcionais e estratégias de resistência à seca entre espécies decíduas e sempre verdes tropicais. *Rodriguésia*, 66(1): 021-032.
- Srivastava, H.S. 1980. Regulation of nitrate reductase activity in higher plants. *Phytochemistry*, 19 (5): 725-73.
- Steffen, W.; Crutzen, P.J. & McNeill, J.R. 2007. The Anthropocene: Are humans now overwhelming the great forces of Nature? *Ambio*, 36: 614–621.
- Stewart, G.R. & Orebamjo, T.O. 1983. Studies of nitrate utilization by the dominant species of regrowth vegetation of tropical West Africa: a Nigerian example, pp. 167-188. In *Nitrogen as an Ecological Factor*, eds J. A. Lee, S. McNeill and I. H. Rorison, 470 pp. Blackwell Scientific Publications, Oxford.
- Stewart, G.R.; Popp, M.; Holzapfel, I.; Stewart, J.I. & Dickie-Eskew A. 1986. Localization of nitrate reduction in ferns and its relationship to environment and physiological characteristics. *New Phytologist*, 104: 373-384.
- Stewart, G.R.; Hegarty, E.E. & Specht, R.L. 1988. Inorganic nitrogen assimilation in plants of Australian rainforest communities. *Physiology Plant*, 74:26-33.
- Stewart, G. R.; Gracia, C. A.; Hegarty, E. E. & Specht, R. L. 1990. Nitrate Reductase Activity and Chlorophyll Content in Sun Leaves of Subtropical Australian Closed-Forest (Rainforest) and Open-Forest Communities *Oecologia*, 82 (4): 544-551.
- Stewart, G.R.; Joly, C.A. & Smirnoff, N. 1992. Partitioning of inorganic nitrogen assimilation between the roots and shoots of cerrado and forest trees of contrasting plant communities of South East Brasil. *Oecologia*, 91:511-517.

- Swaine, M.D. & Whitmore, T.C. 1988. On the definition of ecological species groups in tropical rain forests. *Vegetatio*, 75: 81–86.
- Stulen, I.; Perez-Soba, M.; De Kok, L.J. & Van Der Eerden, L. 1998. Impact of gaseous nitrogen deposition on plant functioning. *New Phytologist*, 139:61–70.
- Tabarelli, M., Mantovani, W. & Peres, C.A. 1999. Effects of habitat fragmentation and plant guild structure in the montane Atlantic forest of southeastern Brazil. *Biological Conservation*, 91:119–127.
- Tabarelli, M.; Silva, J.M.C. & Gascon, C. 2004. Forest fragmentation, synergisms and the impoverishment of neotropical forest. *Biodiversity and Conservation*, 13:1419–1425.
- Tabarelli, M.; Peres, C.A. & Melo, F.P.L. 2012. The ‘few winners and many losers’ paradigm revisited: emerging prospects for tropical forest biodiversity. *Biological Conservation*, 155: 136–140.
- Taiz, L. & Zeiger, E. 2002. *Plant physiology*. California: Sinauer associates. 722p.
- Tang, M.H, Porder, S & Lovett, G.M. 2012. Species differences in nitrate reductase activity are unaffected by nitrogen enrichment in northeastern US forests. *Forest Ecology and Management*, 275:52–59
- Tanner, E.V.J.; Vitousek, P.M. & Cuevas, E. 1998. Experimental investigation of nutrient limitation of forest growth on wet tropical mountains. *Ecology*, 79(1): 10–22.
- ter Steege, H.; Pitman, N.C.A.; Sabatier, D.; Baraloto, C.; Salomão, R.P.; Guevara, J.E. et al. 2013. Hyperdominance in the Amazonian Tree Flora. *Science*, 342(6156):1243092.
- Tobner, C.M.; Paquette, A.; Gravel, D.; Reich, P.B.; Williams, L.J. & Messier, C. 2016. Functional identity is the main driver of diversity effects in young tree communities. *Ecology Letters*, 19: 638–647.
- van Breugel, M.; Bongers, F.; Martínez-Ramos, M. 2007. Species Dynamics during early secondary forest succession: Recruitment, Mortality and Species Turnover. *Biotropica*, 35(5): 610–619.
- Veloso, H.P.; Rangel-Filho, A.L.R. & Lima, J.C. 1991. Classificação da vegetação brasileira adaptada a um sistema universal. IBGE, Rio de Janeiro.
- Viechtbauer, W. 2010. Conducting Meta-Analyses in R with the metaphor Package. *Journal of Statistical Software*, 36 (3).
- Villegger, S.; Mason, N.W.H. & Mouillot, D. 2008. New multidimensional functional diversity indices for a multifaceted framework in functional ecology. *Ecology*, 89(8):2290–2301.

- Violle, C.; Navas, M-L. & Vile, D. et al. 2007. Let the concept of trait be functional! *Oikos*, 116 (5): 882–892.
- Vitousek, P. M.; Gosz, J. R.; Grier, C.C.; Melillo, J.M.; Reiners, W.A. & Todd, R.L. 1979. Nitrate losses from disturbed ecosystems. *Science*, 204:469-474.
- Vitousek, P.M.; Matson, P.A. & van Cleve, K. 1989. Nitrogen availability and nitrification during succession: primary, secondary, and old-field seres. *Plant Soil*, 115:229–239.
- Vitousek, P.M. & Matson, P.A. 1988. Nitrogen transformations in a range of tropical forest soils. *Soil Biology & Biochemistry*, 20:361–367.
- Vitousek, P.M. & Sanford, R.L. Jr. 1986. Nutrient cycling in moist tropical forest. *Annual Review of Ecological Systems*, 17:137-67.
- Vlassak, K. 1970. Total soil nitrogen and nitrogen mineralization. *Plant and soil*, 32:27-32.
- WallisDeVries, M.F. & Bobbink, R. 2017 Nitrogen deposition impacts on biodiversity in terrestrial ecosystems: Mechanisms and perspectives for restoration. *Biological Conservation*, 212: 387–389.
- Wallsgrave, R.M.; Keys, A.J.; Lea, P.J. & Miflin, B.J. 1983. Photosynthesis, photorespiration and nitrogen metabolism. *Plant , Cell and Environment*, 6: 301-9.
- Wardle, D.A. 2002. *Communities and ecosystems. Linking aboveground and belowground components*. Princeton University Press.
- Westbrook, C.; Devito, K.J. & Allan, C.J. 2006. Soil N cycling in harvested and pristine boreal forests and peatlands. *Forest Ecology and Management*, 234:227–237.
- Westoby, M.; Falster, D.S.; Moles, A.T.; Vesk, P.A. & Wright, I.J. 2002. Plant ecological strategies: some leading dimensions of variation between species. *Annual Review of Ecology and Systematics*, 33 (1): 125-159.
- Wilkinson, J.Q., & Crawford, N.M. 1991. Identification of the Arabidopsis CHL3 gene as the nitrate reductase structural gene NIA2. *Plant Cell*, 3:461-471.
- Wilson, P.J.; Thompson, K. & Hodgson JG. 1999. Specific leaf area and leaf dry matter content as alternative predictors of plant strategies. *New Phytologist*, 143: 155–162.
- Winter G., Todd C.D., Trovato M., Forlani G., Funck D. Physiological implications of arginine metabolism in plants. *Frontiers in Plant Science*, 2015, 6: 534.
- Wittemyer, G.; Elsen, P.; Bean, W.T.; Burton, C.O. & Brashares, J.S. 2008. Accelerated human population growth at protected area edges. *Science*, 321: 123–126.
- Wright, I.J. & Cannon, K. 2001. Relationships between leaf lifespan and structural defences in a low-nutrient, sclerophyll flora 15, 351– 359. *Functional Ecology*, 15:351-359.

- Wright, I.J.; Westoby, M. & Reich, P.B. 2002. Convergence towards higher leaf mass per area in dry and nutrient-poor habitats has different consequences for leaf life span. *Journal of Ecology*, 90(3):534–543.
- Wright, I.J.; Reich, P.B.; Westoby, M.; Ackerly, D.D.; Baruch, Z.; Bongers, F.; Cavender-Bares, J.; Chapin, T.; Cornelissen, J.H.C.; Diemer, M.; Flexas, J.; Garnier, E. et al. 2004. The worldwide leaf economics spectrum. *Nature*, 428:821-827.
- Wright, S.J. 2005. Tropical forests in a changing environment. *Trends in Ecology and Evolution*, 20: 553–560.
- Wright, I.J.; Ackerly, D.D.; Bongers, F.; Harms, K.E.; Ibarra-Manriquez, G. et al. 2007. Relationships among ecologically important dimensions of plant trait variation in seven Neotropical forests. *Annals of Botany*, 99: 1003–1015.
- Xia J. & Wan S. 2008. Global response patterns of terrestrial plant species to nitrogen addition. *New Phytologist*, 179: 428–439.
- Zhang, J.L. & Cao, K.F. 2009. Stem hydraulics mediates leaf water status, carbon gain, nutrient use efficiencies and plant growth rates across dipterocarp species. *Functional Ecology*, 23: 658–667.
- Zhang, Q.; Buyantuev, A.; Li, F.Y.; Jiang, L.; Niu, J.; Ding, Y.; Kang, S. & Ma, W. 2017. Functional dominance rather than taxonomic diversity and functional diversity mainly affects community aboveground biomass in the Inner Mongolia grassland. *Ecology and Evolution*, 7:1605–1615.

ANEXO 1. Declaração de Bioética e Biossegurança.



COORDENADORIA DE PÓS-GRADUAÇÃO
INSTITUTO DE BIOLOGIA
Universidade Estadual de Campinas
Caixa Postal 6109, 13083-970, Campinas, SP, Brasil
Fone (19) 3521-6378. email: cpgib@unicamp.br

**DECLARAÇÃO**

Em observância ao §5º do Artigo 1º da Informação CCPG-UNICAMP/001/15, referente a Bioética e Biossegurança, declaro que o conteúdo de minha Tese de Doutorado, intitulada "**FUNCTIONAL NITROGEN USE STRATEGIES IN HUMAN MODIFIED ATLANTIC FOREST GRADIENT**", desenvolvida no Programa de Pós-Graduação em **Biologia Vegetal** do Instituto de Biologia da Unicamp, não versa sobre pesquisa envolvendo seres humanos, animais ou temas afetos a Biossegurança.

Assinatura: Nidia Mara Marchiori
Nome do(a) aluno(a): **Nidia Mara Marchiori**

Assinatura: Marcos Pereira Marinho Aida
Nome do(a) orientador(a): **Marcos Pereira Marinho Aida**

Data: **23 de abril de 2018**

ANEXO 2. Declaração de autoria.

Declaração

As cópias de artigos de minha autoria ou de minha co-autoria, já publicados ou submetidos para publicação em revistas científicas ou anais de congressos sujeitos a arbitragem, que constam da minha Dissertação/Tese de Mestrado/Doutorado, intitulada **FUNCTIONAL NITROGEN USE STRATEGIES IN HUMAN MODIFIED ATLANTIC FOREST GRADIENT**, não infringem os dispositivos da Lei n.º 9.610/98, nem o direito autoral de qualquer editora.

Campinas, 23 de abril de 2018

Assinatura : Nidia Mara Marchiori

Nome do(a) autor(a): **Nidia Mara Marchiori**

RG n.º 43744029-1

Assinatura : Marcos Pereira Marinho Aida

Nome do(a) orientador(a): **Marcos Pereira Marinho Aida**

RG n.º 7623955-X