

*NADJA RODRIGUES DE MELO*

**CARACTERIZAÇÃO DE LEVEDURAS DE CAVIDADE  
ORAL DE CRIANÇAS INFECTADAS PELO HIV-1, ANTES  
E DURANTE O USO DE INIBIDOR DE PROTEASE**

*CAMPINAS*

*2006*

**NADJA RODRIGUES DE MELO**

**CARACTERIZAÇÃO DE LEVEDURAS DE CAVIDADE  
ORAL DE CRIANÇAS INFECTADAS PELO HIV-1, ANTES  
E DURANTE O USO DE INIBIDOR DE PROTEASE**

*Tese de Doutorado apresentada à Pós-Graduação  
da Faculdade de Ciências Médicas da Universidade  
Estadual de Campinas para obtenção do título de  
Doutor em Saúde da Criança e do Adolescente, área  
de concentração em Pediatria*

***ORIENTADOR: Maria Marluce dos Santos Vilela***

**CAMPINAS**

**2006**

**FICHA CATALOGRÁFICA ELABORADA PELA  
BIBLIOTECA DA FACULDADE DE CIÊNCIAS MÉDICAS DA UNICAMP**

Bibliotecário: Sandra Lúcia Pereira – CRB-8ª / 6044

M491c Melo, Nadja Rodrigues de  
“Caracterização de leveduras de cavidade oral de crianças infectadas pelo HIV-1, antes e durante o uso de inibidor de protease” / Nadja Rodrigues de Melo. Campinas, SP : [s.n.], 2006.

Orientador : Maria Marluce dos Santos Vilela  
Tese ( Doutorado ) Universidade Estadual de Campinas. Faculdade de Ciências Médicas.

1. Candida. 2. Cândida Albicans. 3. Infecções por HIV. 4. HIV-1. I. Vilela, Maria Marluce dos Santos. II. Universidade Estadual de Campinas. Faculdade de Ciências Médicas. IV. Título.

**Título em ingles: Characterization of cândida oral flora in HIV –1 infected children in the HAART era**

**Keywords:** • Candida

- Candida Albicans
- HIV Infections
- HIV-1

**Área de concentração : Pediatria**

**Titulação: Doutorado**

**Banca examinadora: Profa. Dra. Maria Marluce dos Santos Vilela**

**Profa. Dra. Márcia Mussi Pinhata**

**Profa. Dra. Maria Isabel Moraes Pinto**

**Prof Dr Marcos Tadeu Nolasco da Silva**

**Prof Dr Jacks Jorge Júnior**

**Data da defesa:24/02/2006**

## **Banca Examinadora da Tese de Doutorado**

---

### **Orientadora:**

**Profa. Dra. Maria Marluce dos Santos Vilela**

### **Membros:**

**1. Profa. Dra. Maria Marluce dos Santos Vilela**

**2. Profa. Dra. Marisa Marcia Mussi Pinhata**

**3. Profa. Dra. Maria Isabel de Moraes Pinto**

**4. Prof. Dr. Marcos Tadeu Nolasco da Silva**

**5. Prof. Dr. Jacks Jorge Junior**

**Curso de Pós-graduação em Saúde da Criança e do Adolescente da  
Faculdade de Ciências Médicas da Universidade Estadual de Campinas.**

**Data: 2006**

A realização deste projeto foi viabilizada pela **FAPESP, CAPES**, e *Japan International Cooperation Agency (JICA)*, através da concessão de bolsa e auxílio-pesquisa.

*Esta tese vai dedicada ao Prof. Dr. Jacks Jorge Júnior, sempre semeando e colhendo frutos. Hoje te agradeço e me sinto um desses frutos com muito orgulho!*

*Em especial a minha família que permanece intocável.*

*Á Profa. Dra. Maria Marluce dos Santos Vilela, por todo seu entusiasmo na orientação, dedicação inestimável a carreira acadêmica que é um exemplo admirável. Sua amizade, brilho de vida, suporte incomensurável e serenidade foram essenciais no desenvolvimento e conclusão desta tese. É com imensa alegria e orgulho que conquistamos esta vitória.*

## **AGRADECIMENTOS**

---

Ao **Prof. Dr. Makoto Miyaji** um exemplo de dedicação e amor à ciência, foi um privilégio ter sua orientação e apoio na Universidade de Chiba-Japan.

Ao **Prof. Hideaki Taguchi** compartilhar a rotina laboratorial com seus ensinamentos e orientação, sempre com admirável bom humor e alegria foi algo muito suave e especial. Sua marcante participação contribuiu para o despertar do senso de pesquisa que tenho hoje.

À Faculdade de Ciências Médicas - UNICAMP, na pessoa de sua diretora Profa. Dra. Lilian Tereza Lavras Costallat.

Ao Coordenador dos cursos de pós-graduação da Faculdade de Ciências Médicas – UNICAMP, Prof. Dr. José Guilherme Cecatti.

Ao Coordenador do curso Saúde da Criança e do Adolescente da Faculdade de Ciências Médicas – UNICAMP, Prof. Dr. Antonio de Azevedo Barros Filho.

Ao **Prof. Dr. Fausto Bérzin**, Departamento de Morfologia da Faculdade de Odontologia de Piracicaba - UNICAMP, meu primeiro orientador durante a graduação quando fui bolsista do PET/CAPES.

Ao apoio incomensurável da amiga **Vitória Culhari**, exemplo de profissional responsável, leal e espírito de equipe, do Centro de Investigação em Pediatria (CIPED/FCM/UNICAMP).

Aos bioestatísticos **Cleide** e **Helymar** da Faculdade de Ciências Médicas - UNICAMP pelo inestimável apoio e exemplo de organização.

Aos **funcionários do CIPED**, Faculdade de Ciências Médicas UNICAMP sempre atenciosos, em especial Maria Helena sempre trabalhando com alegria e responsabilidade.

Aos **professores** do Departamento de Pediatria, Faculdade de Ciências Médicas UNICAMP pelo apoio e amizade.

A todos os **pesquisadores** pois através de seus estudos despertam-se tantas outras idéias.

Principalmente aos **Pacientes** com os quais estou sempre aprendendo seja na vida ou com a pesquisa.



*" ...um discípulo nunca pode imitar os passos de seu guia. Porque cada um tem uma maneira de ver a vida, de conviver com as dificuldades e com as conquistas. Ensinar é mostrar que é possível. Aprender é tornar possível a si mesmo."*

**Paulo Coelho**

*" Mestre não é quem sempre ensina, mas quem de repente aprende."*

**Guimarães Rosa**

## SUMÁRIO

---

	<i>Pág.</i>
<b>RESUMO</b> .....	<i>xxvii</i>
<b>ABSTRACT</b> .....	<i>xxxii</i>
<b>INTRODUÇÃO GERAL</b> .....	35
<b>OBJETIVOS</b> .....	45
<b>CAPITULOS</b> .....	49
<b>Capítulo 1</b> .....	51
<b>Capítulo 2</b> .....	75
<b>Capítulo 3</b> .....	95
<b>Capítulo 4</b> .....	117
<b>DISCUSSÃO GERAL</b> .....	139
<b>CONCLUSÃO GERAL</b> .....	147
<b>REFERÊNCIAS BIBLIOGRÁFICAS</b> .....	151
<b>ANEXOS</b> .....	173

## ***LISTA DE ABREVIATURAS***

---

<b>AIDS</b>	Acquired Immune Deficiency Syndrome
<b>ATCC</b>	American Type Culture Collection
<b>Bq</b>	becquerel
<b>CDC</b>	Center of Control Disease Control and Prevention
<b>CFU</b>	colony formation unit
<b>Ci</b>	curie
<b>Dpm</b>	disintegration per minute
<b>Grupo PI</b>	crianças infectadas pelo HIV-1 antes do uso de Inibidores de protease
<b>Grupo PII</b>	crianças infectadas pelo HIV-1 após o uso de Inibidores de protease
<b>H<sub>3</sub></b>	tritium
<b>HAART</b>	highly active antiretroviral therapy
<b>HIV</b>	human immunodeficiency virus
<b>IP</b>	inibidores de protease
<b>MIC</b>	Inhibitory concentration
<b>NCCLS</b>	National Committee for Clinical Laboratory Standards
<b>PCR</b>	polymerase chain reactions
<b>RAPD</b>	random amplified polymorphic DNA
<b>RPM</b>	revolution per minute
<b>OD</b>	optical density
<b>BCT</b>	biocell tracer system

## LISTA DE TABELAS

---

**Manuscrito 1** - “Follow up Study - Oral *Candida* Flora from Brazilian HIV 1-Infected Children in the HAART Era”

	<i>Pág.</i>
<b>Table 1</b> - Distribution of 52 HIV-infected children by Clinical and Immunological category.....	58
<b>Table 2</b> - Oral <i>Candida</i> colonization in the groups GI and GII.....	58
<b>Table 3</b> - Yeast isolates from HIV-infected children.....	59
<b>Table 4</b> - Association between oral manifestation and <i>Candida</i> species colonization in the group GII.....	59
<b>Table 5</b> - Association between immunological category and <i>Candida</i> species identified in the GI and GII groups.....	60
<b>Table 6</b> - Association between oral manifestation and immunological category..	60
<b>Table 7</b> - Association between oral manifestations associated to HIV-infection and immunomarkers.....	60
<b>Table 8</b> - Antifungal susceptibility of <i>Candida</i> spp.....	61

**Manuscrito 2** - “Antifungal Cross-resistance in an Oral *Candida* Isolate from a Pediatric Patient”.

	<i>Pág.</i>
<b>Table 1</b> - Drug susceptibilities of the <i>C. albicans</i> isolates.....	87
<b>Table 2</b> - Effect of antifungal drugs on the <i>Candida</i> specific growth rate.....	88
<b>Table 3</b> - Accumulation of [ <sup>3</sup> H] fluconazole in presence of NaN <sub>3</sub> in <i>C. albicans</i> clinical isolates.....	89
<b>Table 4</b> - Sterol composition of <i>C. albicans</i> isolates.....	90

**Manuscrito 3** - “*Candida dubliniensis* in a Brazilian family with an HIV-1 infected child: Identification, antifungal susceptibility, drug accumulation and sterol composition”.

	<i>Pág.</i>
<b>Table 1</b> - Characteristics of the eight family members with an HIV-infected child.....	110
<b>Table 2</b> - MICs for antifungal drugs in <i>C. dubliniensis</i> isolates.....	114
<b>Table 3</b> - Accumulation of [ <sup>3</sup> H] fluconazole (dpm/min) in presence of NaN <sub>3</sub> in clinical <i>C. dubliniensis</i> isolates.....	115
<b>Table 4</b> - Sterol profile of <i>C. dubliniensis</i> clinical isolates.....	116

## LISTA DE FIGURAS

---

**Manuscrito 3** - “*Candida dubliniensis* in a Brazilian family with an HIV-1 infected child: Identification, antifungal susceptibility, drug accumulation and sterol composition”.

	<i>Pág.</i>
<b>Fig. 1</b> - Diagram of the species identified amongst the isolates from the family members of the HIV-infected child.....	111
<b>Fig. 2</b> - The gel image of amplification of <i>C.dubliniensis</i> specific gene in cytochrome <i>b</i> .....	112
<b>Fig. 3</b> - The gel image of RAPD fingerprinting patterns of <i>C.dubliniensis</i> isolates.....	113

**Manuscrito 4** - “HIV-1 Anti-retroviral Drug Effect on the Growth Rate of *C. albicans* Single Hyphal by a Bio-Cell Tracer System”.

	<i>Pág.</i>
<b>Fig. 1</b> - Percentage of specific growth rate (cells.h <sup>-1</sup> ) of <i>C. albicans</i> in the presence of amphotericin B and ritonavir at concentration ranging from 0.125 to 64 µg/ml.....	126
<b>Fig. 2</b> - Time course of the growth rate of individual hyphae of <i>C. albicans</i> control.....	127
<b>Fig. 3</b> - Time course of the growth rate of individual hyphae of <i>C. albicans</i> in the presence of ritonavir.....	128
<b>Fig. 4</b> - Time course of the growth rate of individual hyphae of <i>C. albicans</i> in the presence of amphotericin.....	129

***RESUMO***

O presente estudo caracterizou a flora oral de *Candida* em 52 crianças infectadas pelo HIV-1 em dois períodos, definidos como período I antes da introdução de inibidores de protease no esquema de terapia antiretroviral para HIV-1 e período II após a introdução de inibidores de protease. Comparou-se as espécies de *Candida* identificadas nos períodos I e II.

Isolados do períodos I foram identificados e as crianças em sua maioria (80%) estavam colonizadas por *C. albicans*. Redução no percentual de colonização por *C. albicans* de 80% para 52%, nos períodos I e II respectivamente, sugere mudança na colonização oral por *Candida* após a introdução da terapêutica com inibidores de protease HIV (IP). Destaca-se particularmente o aumento da incidência de isolados Não-*albicans* ( $p=0.005$ ) no período II. No período I haviam 8 crianças que estavam colonizadas por espécies Não-*albicans* e no período II haviam 20 crianças colonizadas com isolados Não-*albicans*. Investigou-se a prevalência de *C. dubliniensis* na família de uma das crianças que estava colonizada por esta levedura. Do total de 52 crianças 38.4% mostraram manifestação oral associada a colonização por *Candida*. Observou-se alta sensibilidade dos isolados aos agentes antifúngicos testados, mas 4% dos isolados exibiram resistência ao fluconazol. Documentou-se resistência cruzada entre agentes antifúngicos em isolado de *Candida albicans* em uma criança infectada pelo HIV-1 não previamente exposta a azoles. Um isolado de *C. tropicalis* mostrou baixa susceptibilidade ao fluconazol ( $MIC \geq 64 \mu\text{g/ml}$ ) (1). O presente estudo revelou mudança significativa na colonização oral por *Candida* em crianças infectadas pelo HIV-1 sob terapia HAART (Highly Active Antiretroviral Therapy). Houve alta diversidade de espécies de *Candida*, com emergência de espécies Não-*albicans* após o uso de Inibidores de protease.



***ABSTRACT***

This study characterized the *Candida* oral flora from 52 Brazilian HIV 1-infected children, comparing the *Candida* species identified in two periods before (PI) and under (PII) the introduction of the HIV Protease Inhibitor therapy. The majority (80%) of the children from the PI group were colonized by *C. albicans*. Children in the PII (52%) were colonized by *C. albicans* and 28% of them carried on mixed colonization (*C. albicans* and Non-*albicans* isolates). Therefore when we compared the periods I and II, after the inhibitor protease usage there was an important decrease in the percentile of colonization for *C. albicans* of 80% to 52%, suggesting an important change of the *Candida* oral colonization after the HIV protease inhibitors introduction. Particularly with increase of the Non-*albicans* isolates incidence (p=0.005) in the period II. In PI there were 8 children that were colonized by Non-*albicans* species and in the PII there were 20 children colonized with Non-*albicans* isolates. Rare *Candida* species were identified, particularly we investigated the *C. dubliniensis* prevalence in a HIV-infected child's family. Of 52 children in this study 20 (38.4%) of them showed oral lesions associated to the *Candida* colonization.

In spite of the high susceptibility of the isolates to the antifungal agents tested in this study, 4.4% (n=2) exhibited resistance to the fluconazole. One of the isolates was *C. albicans* from a HIV-infected child not prior exposure to azoles, which showed antifungal cross-resistance. One *C. tropicalis* isolate has shown low susceptibility to fluconazol (MIC  $\geq$  64  $\mu$ g/ml). This study was succeeded in showing the inhibitory effect of ritonavir on a single hyphae tip growth of *C. albicans*.

The present investigation revealed a significative change of the *Candida* oral colonization in Brazilian HIV-infected children under HAART, high diversity of *Candida* species and Non-*albicans* species emergence after IP usage.

## ***INTRODUÇÃO GERAL***

O gênero *Candida* está presente como flora natural sobre as mucosas de várias partes do trato gastrointestinal e vagina em 10%-50% dos indivíduos sadios. Em tal habitat a *C. albicans* vive em balanço com outros membros da flora microbiana e existe como colonizadora. A prevalência de colonização fúngica da cavidade oral de indivíduos normais diverge na literatura. Índices de 18% a 60% são descritos, sendo a média de 40% (1). A idade é o fator que mais influencia esta colonização e as maiores taxas ocorrem em crianças de 1 semana a 18 meses de idade. A colonização neonatal inicial ocorre a partir de várias origens incluindo: transmissão no momento do nascimento, aleitamento materno, mãos de profissionais da saúde e pessoas que manipulam o recém - nascido.

*C. albicans* pode ser detectada em pessoas sadias, persistir em pacientes sob terapia com antibióticos e imunossuppressores, submetidos à cirurgia de transplante, tubação orotraqueal e naqueles com imunodeficiência celular e/ou neutropenia, como na AIDS, onde é a mais representativa das micoses oportunistas (2-4). Cerca de 90%-95% das pessoas infectadas pelo HIV-1 experimentam candidíase em mucosa oral e esôfago, e apenas poucos desenvolvem candidíase sistêmica. O mecanismo de “switch” de *C. albicans* saprófita em um portador saudável para a forma virulenta em pessoa infectada pelo HIV-1 não está totalmente esclarecido (5-10).

Imunidade adquirida para *Candida albicans* está geralmente presente no indivíduo adulto imunocompetente, como expressão de hipersensibilidade retardada positiva para o fungo e, supostamente, previne a colonização da mucosa para a progressão de infecção sintomática. Defeito da reatividade de hipersensibilidade retardada e níveis elevados de IgE, IgA e IgG antígeno específico são frequentemente observados em indivíduos imunodeficientes, em pacientes com infecção persistente ou recorrente com a levedura ou imunopatologia associada com ela. Estas observações questionam uma regulação recíproca da imunidade humoral e mediada por célula para *Candida albicans* e apresenta aspectos compatíveis com o paradigma Th1/Th2 de imunidade adquirida para patógenos (11, 12). Estudos em camundongos demonstraram que a evolução da infecção sistêmica e de mucosa com *C. albicans* depende, sobretudo, da subpopulação de TCD4 predominante. Tem sido demonstrado que a proteção se correlaciona com a do tipo Th1, enquanto a resposta Th2 está associada com patologia e exacerbação de doença.

Em camundongos uma variedade de fatores controla o desenvolvimento de células TCD4+ e a candidose. As citocinas parecem ter papel principal, agindo não apenas como moduladores de funções efetoras antifúngicas mas também, como chaves reguladoras no desenvolvimento das diferentes subpopulações de Th a partir da célula precursora Th0.

A regulação do sistema imune em crianças infectadas pelo HIV-1, pode ser demonstrada pela imunoglobulinemia precoce observada nestes pacientes, configurando um padrão Th2 de reposta e conseqüentemente maior susceptibilidade para *Candida* (13).

O desenvolvimento de resposta protetora Th1 anti-*Candida* requer ações combinadas de várias citocinas tais como interferon- $\gamma$ , fator transformador de crescimento TGF e IL12 na ausência relativa de citocinas Th2, tais como IL-4 e IL10, as quais poderiam inibir o desenvolvimento de resposta Th1. Contudo, em camundongos altamente susceptíveis, a IL12 não exerce efeitos benéficos no curso da evolução de infecções disseminadas e de mucosa. Além disso a administração de IL-4 não converteu a resposta Th1 já estabelecida para uma resposta Th2 e redução de IL-4 exacerbou a infecção crônica.

Estes achados indicam a existência de circuitos imunoregulatórios complexos subjacentes à atividade de citocinas em camundongos com candidose. Outros estudos em camundongos geneticamente modificados revelaram a existência de um padrão hierárquico de regulação mediada por citocinas no desenvolvimento da função efetora da célula Th anti-*Candida*. No início da infecção, a produção de algumas citocinas proinflamatórias TNF, IL6 mais do que IL10, parece ser essencial no sucesso do controle da infecção e imunidade protetora Th1 dependente. Ambos, produção e resposta de IL-12 são necessários para desenvolver o padrão Th1 cuja ativação depende da presença fisiológica de IL-4 e IL-10. Assim um balanço finamente regulado de citocinas, tais como IL4, IL10 e IL12 mais do que a ausência de citocinas opostas, parece ser necessário para o ótimo desenvolvimento e manutenção da reatividade de Th1 em camundongo com candidose (14).

Por outro lado há numerosos mecanismos pelos quais os fungos podem invadir regular as defesas natural e adquirida do hospedeiro. Os fungos que causam doença no homem tendem a ter baixa virulência pois combinação de suas capacidades de subverter as defesas do hospedeiro para estabelecer e perpetuar o processo de doença. Perfeito

entendimento destas complexas interações organismo/hospedeiro e seu impacto sobre a evolução da doença deve permitir melhor avaliação da condição individual do paciente e seleção de terapêutica apropriada.

Há várias sugestões sobre os mecanismos que levam a falhas na imunidade de mucosa. Alguns incluem a deficiência celular relacionada com a infecção pelo HIV-1 (15) e outros discordam sugerindo que:

- 1- A quantidade de leveduras de *C. albicans* aumenta no início da infecção pelo HIV-1 sem qualquer correlação com as células TCD4+ (16);
- 2- *C. albicans* isolada de indivíduos infectados pelo HIV-1 mostra aumento da virulência independente do estado imune do paciente (17);
- 3- os produtos do HIV promovem a sobrevivência e replicação de *C. albicans* devido a destruição de células fagocíticas (18);
  - 3.1- gp160 e gp41, mas não gp120, ligam-se ao receptor CR3 análogo de complemento sobre a *C. albicans*. Esta interação pode ser, em parte, responsável pela virulência alterada de *C. albicans* nestes pacientes (19, 20);
  - 3.2- gp160 e ou gp120 afetam intensamente a viabilidade de *C. albicans*, sua habilidade de gerar hifas e sua atividade de fosfolipase (21, 22);
  - 3.3- gp160 ou gp41, mas não gp120, aumenta a secreção e atividade da família aspartato proteinase (22);
  - 3.4- gp160 e ou gp120 não afetam a fosfolipase extracelular ativa (preditiva para mortalidade em modelo murino de candidose disseminada (22, 23);
  - 3.5- gp41 também aumenta a atividade de proteinase (22);

- 3.6- Aspartato proteinase parece ser a isoenzima clinicamente mais relevante, especialmente no caso de indivíduos infectados pelo HIV-1 (23);
- 3.7- *C. albicans* isolada de paciente infectado pelo HIV-1 tem maior produção de proteinase aspartato (24, 25) e a interação entre gp160 ou gp41 e *C. albicans* pode ser a causa (26);
- 3.8- gp160 ou gp 41 reduz a fagocitose por polimorfonuclear (PMN) de *C. albicans* viável opsonizada, pré-tratada com as proteínas do envelope, justificando o aumento de leveduras na saliva destes pacientes;
- 3.9- A interação de gp160 ou gp41 com *C. albicans* pode também desencadear a liberação de outros imunomoduladores, como produtos inibitórios de hifas (*candida* hyphal inhibitory product) secretados por *C. albicans* e inibir as funções de PMN;
- 3.10- A ligação das proteínas do envelope do HIV-1 com *C. albicans* aumenta a sua virulência e altera a interação *in vitro* com as células do hospedeiro. Estes efeitos parecem ser induzidos por gp41 e não por gp120.

Alguns dos agentes causadores de micose sofrem transformação morfológica de suas formas saprofiticas de levedura-like para micélio (forma parasítica) no tecido do hospedeiro. Este fenômeno de dimorfismo é um dos fatores mais importantes da patogenicidade de alguns fungos.

Fagocitose de *C. albicans* por granulócitos ocorre durante os estágios iniciais da infecção e durante os estágios tardios a sua morte ocorre pela atividade de macrófagos. Demonstrou-se que o camundongo nu/nu é mais susceptível do que o nu/+, indicando que a fagocitose tem relevante papel durante o início da infecção e a imunidade mediada por célula durante a fase tardia. A defesa no camundongo nu/nu consiste principalmente de um step, fagocitose por granulócitos.

Deste modo, é provável que a candidose em indivíduos infectados pelo HIV-1 pode ser causada por vários fatores: interação direta entre as proteínas do envelope e *C. albicans*; alterações nos mecanismos específicos e inespecíficos de defesa do hospedeiro e virulência das cepas.

Embora existam mais de 150 espécies correntemente listadas dentro do gênero *Candida* (28). *C. albicans* é a mais associada com doença humana. Contudo, nos últimos anos a incidência de infecções causada por outras espécies, incluindo *C. tropicalis*, *C. glabrata*, *C. parapsilosis*, *C. krusei* e *C. lusitaniae*, tem sido relatado com alta frequência (28-31). Devido à sua menor susceptibilidade aos antifúngicos, estas espécies estão mais associadas aos casos recorrentes de doença (32). As espécies identificadas como patogênicas para o homem inclui: *C. albicans*, *C. stellatoidea*, *C. tropicalis*, *C. parapsilosis*, *C. krusei*, *C. pseudotropicalis*, *C. glabrata* e mais recentemente *C. dubliniensis* (33, 34).

*Candida dubliniensis* expressa níveis significativamente mais altos de atividade de proteinase e possui maior capacidade de aderir às células epiteliais da boca comparadas aos isolados de *C. albicans* típica. Em certos aspectos, a *candida* atípica pode ter maior virulência quando comparada às cepas clássicas de *C. albicans* (35). No entanto demonstramos recentemente que a *Candida dubliniensis* tem menor virulência do que *C. albicans* (36).

### **Apresentação clínica da Candidose**

Odds (1984) (37) classificou os fatores predisponentes para a infecção por *Candida* em:

a- naturais: outras infecções, diabetes e outras endocrinopatias, imunodeficiências congênitas ou adquiridas de fagócitos, malignidades como leucemias e linfomas, alterações do estado fisiológico como infância, gravidez, idade avançada; dietas ricas em carboidratos e pobres em vitaminas; b- mecânicos: próteses dentárias; c- iatrogênicos: uso de contraceptivos hormonais, antibióticos, corticoides e outros imunossupressores.

A candidose oral ocorre de forma: **Aguda**, cuja apresentação é pseudomembranosa e atrófica e **Crônica** atrófica, hiperplásica e mucocutânea (1, 38).



A candidose pseudomembranosa é a mais comum, principalmente em crianças, idosos e pacientes com doenças terminais. Com frequência está associada a diabetes melitus, leucemia e AIDS e se apresenta como placas esbranquiçadas que, ao serem removidas, expõem área eritematosa e, algumas vezes, sangram.

A candidose atrófica aguda caracteriza-se pela presença de eritema e dor em queimação e a atrófica crônica pela mucosite eritematosa e queilite angular, às vezes assintomática, comumente associada (60%) aos usuários de próteses dentárias, com predominância no sexo feminino.

Candidose hiperplástica crônica é uma variação da candidose oral, mais frequente em tabagistas, e não raro acompanha-se de atipia epitelial ou degeneração maligna do tecido.

Candidose mucocutânea é marcada pela presença de lesões superficiais multifocais, associa-se com poliendocrinopatias e deficiências de imunidade celular. Nas crianças, a maioria dos casos ocorre antes dos 3 anos de idade como candidose oral recorrente, em algumas antes dos 6 meses e outros apenas na adolescência. Com a AIDS, houve um aumento significativo dos casos em adultos jovens.

Entretanto, apesar do aumento de casos de candidose superficial, ainda são poucos os relatos de candidose sistêmica neste grupo de pacientes. Geralmente quando há candidemia, tal complicação ocorre em doentes terminais hospitalizados por longos períodos com outros fatores de risco para esta micose.

### **Candidose em crianças**

Candidose de orofaringe entre lactentes imunocompetentes pode ser considerado um evento normal. *Candida* é adquirida inicialmente na passagem pelo canal de parto e no aleitamento materno, podendo ser recuperada da orofaringe no primeiro dia de vida. A colonização aumenta gradualmente nas semanas seguintes de tal modo que mais de 80% dos lactentes está colonizado com 4 semanas de idade. Contudo os sintomas podem se desenvolver em poucos dias e, na criança imunocompetente é frequentemente tratável. Dermatite de fraldas pode permanecer durante a infância mas, candidíase oral na ausência

de fatores como antibióticoterapia, raramente é encontrada após os 6 meses de vida. A candidose neonatal sistêmica ocorre mais frequentemente em recém-nascido de baixo peso e cuja colonização pode ser o canal de parto ou as mãos de funcionários e uso de nutrição parenteral.

Candidose oral ocorre em pelo menos 15-40% das crianças com diagnóstico de infecção pelo HIV-1 no primeiro ano de vida (7). O defeito imunológico central é na imunidade mediada por célula explicando o elevado risco de candidíase em mucosa, criptococose, histoplasmose e coccidioidomicose (11). Alterações das funções das células T CD4+ em crianças infectadas com HIV-1 estão correlacionadas com um risco aumentado de infecções oportunistas, incluindo candidíase esofágica e orofaríngea persistentes. Enquanto a candidíase mucocutânea é comum em crianças infectadas pelo HIV-1, a candidíase disseminada é um evento incomum na história natural desta infecção, a menos que haja fator de risco como uso de catéter endovenoso (15).

A infecção oportunista mais grave é a pneumonia fúngica que ocorre em 30% a 50% das crianças infectadas. Outras frequentes são candidose oral recorrente, herpes zooster, tuberculose, porém em índices menores aos observados em adultos.

No Brasil, a candidose oral é a infecção mais frequente, associada a AIDS em menores de 13 anos (9,0%), no momento da notificação, seguida pela febre prolongada (7,8%), tuberculose (2,3%), aumento crônico de parótida (2,0%), herpes zooster (0,9%), miocardiopatia (0,8%), hepato e ou esplenomegalia (9,2%) (42).

### **Agentes Antifúngicos**

A emergência de outras espécies de *Candida* não-*albicans*, como patógenos oportunistas que são mais resistentes a agentes antifúngicos do que a *C. albicans*, tornou-se importante problema clínico em medicina (43). Desde 1989, fluconazol tem sido usado em larga escala na profilaxia e tratamento de candidose orofaríngea em pacientes com AIDS (44). *C. glabrata* freqüentemente é menos susceptível ao fluconazol que as demais espécies de *Candida*. *C. krusei* é freqüentemente associada a infecções com alta taxa de mortalidade e sua resistência ao fluconazol parece ser inerente (43). Portanto é de extrema importância

o diagnóstico fidedigno e rápido, com técnicas laboratoriais simples e de custo aceitável na rotina de microbiologia clínica, permitindo assim a adaptação da terapêutica antifúngica.

O aumento da frequência de infecções fúngicas intensificou a seleção de novos agentes no combate a infecções graves, mais seguros e eficazes. A aprovação dos primeiros agentes antifúngicos no fim dos anos oitenta foi o mais importante avanço no tratamento de infecções fúngicas sistêmicas desde a descoberta dos mesmos (43).

A ocorrência de espécies de *Candida* não-*albicans* em pacientes com AIDS varia entre 14% e 35% com predomínio da *C. krusei*, *C. glabrata* e *C. tropicalis* (45, 46). O uso de compostos azólicos na terapia destes pacientes tem gerado uma pressão seletiva levando ao aumento da prevalência de colonização e infecção por leveduras diferentes de *C. albicans*, sobretudo *C. krusei* e *C. glabrata* (32).

O estudo de resistência a agentes antifúngicos está defasado em relação aos estudos sobre resistência a antibióticos. Entre 1950 e 1970, a taxa anual de mortes por candidose ficou estável (43). Entretanto, desde 1970 esta taxa tem aumentado significativamente em associação com as várias mudanças na clínica médica, incluindo o uso difundido de terapias imunossupressoras, uso indiscriminado de agentes antibacterianos de largo espectro e o advento da AIDS. A importância das infecções por *Candida* na infecção por HIV-1, a crescente proporção de espécies não-*C. albicans* envolvidas (45, 47) e a variação de susceptibilidade aos antifúngicos (32), exigem identificação acurada dos isolados clínicos e avaliação da susceptibilidade ou resistência aos antifúngicos.

## ***OBJETIVOS***

**Manuscrito 1 - “Follow up Study - Oral *Candida* Flora from Brazilian HIV 1-Infected Children in the HAART Era”.** (em preparação)

**Objetivo:** Caracterização das espécies de *Candida*, na flora oral de crianças infectadas pelo HIV-1, identificadas antes e após a introdução da terapêutica com inibidores de protease.

**Manuscrito 2 - “Antifungal Cross-resistance in an Oral *Candida* Isolate from a Pediatric Patient”.** (submetido, FEMSYR ref. 05050088).

**Objetivo:** Documentou resistência cruzada entre agentes antifúngicos em isolado de *Candida albicans* em uma criança infectada pelo HIV-1 não previamente exposta a azoles. Os possíveis mecanismos de resistência envolvidos foram descritos.

**Manuscrito 3 - “*Candida dubliniensis* in a Brazilian family with an HIV-1 infected child: Identification, antifungal susceptibility, drug accumulation and sterol composition”.** (aceito para publicação, Brazilian Journal of Microbiology ref. 009/06).

**Objetivo:** Investigou-se a prevalência de *C. dubliniensis* em uma família brasileira com uma criança infectada pelo HIV-1. Estudou-se os aspectos genéticos e fenotípicos dos isolados de *C. dubliniensis* obtidos neste estudo.

**Manuscrito 4 - “HIV-1 Anti-retroviral Drug Effect on the Growth Rate of *C. albicans* Single Hyphal by a Bio-Cell Tracer System”.** (aceito para publicação, Brazilian Journal of Microbiology, ref. 178/05).

**Objetivo:** Estudou-se o efeito de um inibidor de protease HIV no crescimento de hifas de *C. albicans* através do sistema *bio-cell tracer*.

# *CAPÍTULOS*

## CAPÍTULO 1

(manuscript in preparation)

**Follow up Study - Oral *Candida* Flora  
from Brazilian HIV 1-Infected Children  
in the HAART Era**

NADJA R. MELO<sup>1\*</sup>, VITORIA V. P. CULHARI,<sup>1</sup>  
HIDEAKI TAGUCHI<sup>2</sup>, AYAKO SANO<sup>2</sup>, KAZUTAKA FUKUSHIMA<sup>2</sup>,  
STEVEN L. KELLY<sup>3</sup> and M. MARLUCE S. VILELA<sup>1</sup>

<sup>1</sup>*Center of Pediatric Investigation, University of Campinas State, Brazil,*

<sup>2</sup>*Research Center for Pathogenic Fungi and Microbial Toxicoses, Chiba University, Chiba,  
Japan and* <sup>3</sup>*School of Medicine, Swansea University, Wales*

Corresponding author. Tel: +44 (01792) 20 56 78 ext. 3223; Fax: +44 (01792) 51 30 54;

E-mail: [nadjarm@yahoo.com](mailto:nadjarm@yahoo.com)

## Abstract

This study characterized the *Candida* oral flora from 52 Brazilian HIV 1-infected children, comparing the *Candida* species identified in two periods before (PI) and under the HIV Protease Inhibitor therapy (PII). There was a significant increase of non-*albicans* isolates from 9.6% to 28.8% ( $p=0.005$ ) between PI and PII groups respectively. In the PII the second most frequent species was *C. tropicalis* (n=9) followed by *C. parapsilosis* (n=8). Rare species found in the PII included *C. dubliniensis*, *C. norvegensis*, *C. humicola* and *C. rugosa*. The majority of the isolates investigated were susceptible to amphotericin B. *C. albicans* (n=22) and non-*albicans* (n=23) isolates were susceptible to fluconazole, voriconazole, itraconazole and ketoconazole. However one *C. tropicalis* isolate was resistant to fluconazole (MIC > 64  $\mu\text{l/ml}$ ) and one *C. albicans*-B isolate showed cross-resistance to all azoles and amphotericin tested. This study represents the first follow up investigation concerning oral *Candida* flora and antifungal susceptibility in Brazilian HIV 1-infected children.



## Introduction

The prevalence of systemic fungal infections has increased significantly during the past decade. This increase has been attributed to wider use of broad-spectrum antibiotics, immunosuppressive agents, hyperalimentation products and central venous catheters, intensive care of low birth weight infants, organ transplantation, and the acquired immunodeficiency syndrome (AIDS) epidemic (48). Candidosis is the most frequent fungal infection in immunocompromised patients, accounting for up to 80% of fungal infections in these patients. Systemic Candidosis has been reported to occur in up to 10% of infants weighing <1 kg (49). Unlike the other opportunistic fungi, *Candida* species are part of the human endogenous microbial flora. They have been isolated from oropharynx of 20% to 50% of healthy humans and from the gastrointestinal tract of about 60% (50). Host defences against *Candida* infection are complex and involve cellular and humoral factors. Disruptions of the mucocutaneous barrier can facilitate local infection. Therefore intravascular catheters and chemotherapy-induced mucositis can predispose the patient to candidal infection. CD4 lymphocytes seems to be a major defence mechanism against superficial infection. AIDS patients with low CD4 lymphocyte counts are therefore especially susceptible to *Candida* infections (51, 52). The majority of *Candida* infections are caused by *Candida albicans* although, recently an increasing number of infections have been associated with other *Candida* species (31, 46, 53-55). Non-*albicans* species accounted for 3.4% of oropharyngeal isolates during the late 1980's compared to 16.8% of isolates during 1990's (56). In Brazil, non-*albicans* isolates accounted for 42.3% of isolates in a previous study with HIV-infected adults (46).

Up to 35% of AIDS patients may have infections caused by non-*albicans* species (57-59) and some of these changes in *Candida* species prevalence have been associated with use of antiretroviral agents (60-62), antibiotics (45) and antifungal agents (45, 63-65). The frequency of resistant strains to antifungal agents is increasing and is related to increased *Candida* variability (48, 54, 66).

In 1995, antiretroviral combination therapy was demonstrated to be more effective than monotherapy in halting disease progression and reducing mortality in AIDS patients (60-62). Recent evidence has indicated a reduction in oral Candidosis amongst HIV-infected patients after the introduction of anti-HIV drugs such as protease inhibitors

(PI) (62, 67-69). Secreted aspartic protease is an important virulence factor of *Candida albicans*, and it is from the same class of aspartic protease of HIV (67, 70-72). In addition to the expected immunorestitution, patients on protease inhibitor therapy may also benefit from the direct antifungal activity of these drugs.

The aim of this study was to characterize the oral *Candida* species present in HIV-infected children under HIV antiretroviral combination therapy HAART (highly active antiretroviral therapy) including protease inhibitor.

## Materials and Methods

**Collection of isolates:** Isolates of oral cavities from 52 HIV-infected children were investigated in two different periods. The children, who acquired HIV vertically, were being monitored at the Pediatric Immunodeficiency Outpatient Service of the Campinas State University. Informed consent was obtained for all patients. Oral swabs were collected from these 52 children during 1998-1999s period when they were under double antiretroviral therapy (period I, PI), and during 1999-2002s when they started HAART including protease inhibitor (period II, PII). Thirty children were male and 22 female. The age varied from 3 to 15 years old,  $5 \pm 3$  (median  $\pm$  SD years). HIV disease classification for children, according to clinical and immunologic category (73), are presented in the Table 1. All oral swabs were plated on chromogenic agar (CHROMagar<sup>®</sup> - France) (74) and incubated at 30°C for 48 hours to characterize the *Candida* isolates. Cultures were routinely inoculated from single colonies. The isolates were grown at 30°C on potato dextrose agar and stored according to Sandven (75).

**Oral manifestation:** Oral lesions associated with HIV disease were classified according to EC-Clearing House criteria, adapted from Pindborg and Axell et al (4,5) and Ramos-Gomez *et al.* (76-78).

**Characterization of isolates:** The isolates were identified according to the standard technique described by Sandven (75). Isolates were cultured on corn meal agar (Difco, USA), supplemented with 1% Tween 80, at 25°C for 7 days for chlamydospore formation. Germ tube formation was performed in calf serum (Gibco BR, USA) at 37°C for

2 to 4 h. Additionally the isolates were serotyped using the *Candida* Check kit<sup>®</sup> (Iatron laboratories, Inc., Japan) and ID32C<sup>®</sup> profiled (bioMerieux, Marcy l'Etoile, France). The temperature test was also used to distinguish *C. albicans* from *C. dubliniensis* by its differential growth at 45°C. Confirmation of *C. dubliniensis* isolates was performed by molecular biotyping (34).

**Antifungal susceptibility test:** MICs were determined by broth microdilution method of National Committee for Clinical Laboratory Standards (NCCLS 2002) (79). Antifungal agents included amphotericine B (AMPH) (Bristol-Myers Squibb, UK), fluconazole (FLCZ) (Pfizer Pharm. Inc. Japan), miconazole (MCZ) (Mochida Pharm. Inc. Japan), ketoconazole (KTZ) (Sigma, St. Louis, USA), and itraconazole (ITCZ) (Janssen-Kyowa Co., Ltd., Japan). Antifungal reagent-grade powders were dissolved in dimethyl sulfoxide solvent (DMSO) to obtain stock solutions of 12.8 mg/ml. A 10-fold serial dilution was performed in RPMI-1640 medium to provide a working solution for each drug giving final concentration ranges of 0.03 to 16 µg/ml for AMPH B, 0.125 to 64 µg/ml for FLCZ, 0.06 to 32 µg/ml for MCZ, 0.06 to 32 µg/ml for KCZ and 0.015 to 8 µg/ml ITCZ. Antifungal agents were serially diluted in 96-well microtiter plates (Falcon, Lincoln Park, N J, USA). The isolates were subcultured onto PDA slants at 30°C for 24 hours. Cell suspensions were prepared in RPMI-1640 medium and were adjusted to give a final concentration approximately  $2.5 \times 10^3$  cells/ml. The microdilution plates were incubated at 30°C and the minimal inhibitory concentration (MIC<sub>80</sub>) were determined visually at 24 and 48 hours. MIC was defined as the lowest concentration of antifungal agent at which 80% inhibition of growth (MIC<sub>80</sub>) compared with that of the growth control well. *C. albicans* ATCC 90028 and ATCC 90029 were used in each microdilution set as internal control. Chi-Square test and Fisher's exact test were applied considering significant differences if  $p < 0.05$ . Breakpoints for antifungal susceptibility have been established for *Candida* isolates tested according to NCCLS.

Statistical analysis of the oral flora changes before and during the use of HAART including protease inhibitor was performed using Mann-Whitney test. The association amongst the variables studied was verified by Fisher exact test at 5% significant level.

## Results

The oral flora of the HIV-infected children were examined prior to and during HAART including protease inhibitor treatment. The study involved 52 patients, the majority of which (90%) were categorized according to the standard clinical disease classification (CDC) as belonging to groups 2 and 3 (Table 1). The majority of the HIV-infected children in the PI group (90%) were colonized by *C. albicans*, with only 2 patients non-colonization with *Candida*, whilst in the PII were 80% colonized by *C. albicans* (Table 2). The prevalence of multiple *Candida* colonization was higher in HIV-infected children from PII, with 28% of patients being colonized by both *C. albicans* and a non-*albicans* species, than in PI patients (10%), ( $p = 0.005$ ) (Table 2). In PI group, there were 8 patients carrying non-*albicans* isolates compared to 20 patients in PII. Therefore there was an increase of the non-*albicans* carriers after introduction of the HAART. Forty-two children from PI group had *C. albicans* isolates prior to protease inhibitor treatment, 27 of which remained *C. albicans* carriers even after protease inhibitor treatment. However 15 children became non-*albicans* carriers after the protease inhibitor treatment. Prior to protease inhibitor treatment, 8 HIV infected children were non-*albicans* carriers. After protease inhibitor treatment, 3 children were no longer carriers and 5 children remained carriers for non- *albicans* species.

Analysis of the serotypes of the *C. albicans* isolates found that *C. albicans* serotype-A was the most common with 48 patients (78%) in PI, which was reduced to 45% in PII. *C. albicans* serotype-A was the most frequent species isolated ( $p=0.005$  McNemar test). Before protease inhibitor treatment there were 48 HIV-infected children colonized with *Candida albicans*-A. After protease inhibitor treatment, this was reduced to 37 children corresponding to a decrease in prevalence from 92% to 71%. Twelve *Candida* species were identified in the PII group compared with 5 *Candida* species in PI group (Table 6). The second most frequent species isolated in Group PII was the *C. tropicalis* ( $n=9$ , 11%) followed by *C. parapsilosis* ( $n=8$ , 10%). *C. dubliniensis* isolates were low in prevalence (1.2%) (Table 3).

Oral lesions were evaluated only on PII group (Table 4). Twenty out of 52 (38%) in PII children examined showed oral lesions associated with *Candida* colonization, 28 (54%) did not show oral lesions, and from these latter group,

19 were *Candida* carriers. Only 4 children showed oral non-*Candida* associated lesions, although three of them were carriers. Amongst HIV-infected children which did not show oral manifestation, 57% (n=16) carried *C. albicans*-A compared with 90% (n=18) of patients with visible oral candidosis (p = 0.033, Fisher test). In the group showing no oral manifestation, 29% were colonized with *C. albicans* and 9% with non-*albicans* species (Table 4). Amongst the children with oral candidosis, 17% were colonized with *C. albicans* and 21% were multiple carriers. *C. albicans* colonization showed similar percentage values for both groups PI and PII. However, to non-*albicans* colonization increased from 4% to 21% between groups PI and PII, particularly in the category 3 patients (Table 5). Candidosis was significantly associated to immunological category 3 (p=0.05, Fisher exact test) (Table 6). The oral lesions presented by the patients were erythematous candidosis (n=9), angular cheilitis (n=4), hairy leukoplakia (n=3), linear erythematous gingivitis (n=2) and pseudomembranous candidosis (n=2).

Analysis of the immunomarkers in the group studied is shown in Table 7. Low values for immunomarkers showed significant results for oral candidosis. Association between oral candidosis and HIV load and CD4 were statistically significant by Mann-Whitney test, (p= 0.05) and (p= 0.03) respectively. Two out of the 9 *C. tropicalis* strains were identified as belonging to the immunological category 1 (p = 0.04, Fisher Test).

The majority of the isolates were susceptible to all antifungal agents tested (Table 8). However one *C. albicans*-B isolate showed low sensitivity to azoles and amphotericin B. Non-*albicans* isolates showed broad range for antifungal susceptibility. Amongst non-*albicans* isolates in the group PII *C. norvegensis* (n=1), *C. tropicalis* (n=1), *C. krusei* and *C. valida* (n=1) were azole-resistant.

**Table 1** - Distribution of 52 HIV-infected children by Clinical and Immunological category according to CDC 1994

Category*	N (%)
1	5 (9.6)
2	23 (44.2)
3	24 (46.1)

\*1 category = CD4 count without alteration; 2 = CD4 count < 25%, and 3 = CD4 count < 15%

**Table 2** - *Candida* oral colonization in the groups PI and PII (n=52)

Species	PI		PII	
	n	%	n	%
Single <i>C. albicans</i>	42	80	27	51,9
Single non- <i>C. albicans</i>	03	5,7	05	9,6
Multiple carriers	05	9,6	15	28,8
Non-colonization	02	3,8	05	9,6
Total	52	99,1	52	99,9

**Table 3** - Yeast isolates from HIV-infected children identified in PI and PII.

Species	PI (%)	PII (%)
<i>C. albicans-A</i>	48 (79)	37 (45.5)
<i>C. albicans-B</i>	-	10 (12.3)
<i>C. tropicalis</i>	4 (6.6)	9 (11)
<i>C. parapsilosis</i>	3 (5)	8 (10)
<i>C. dubliniensis</i>	1 (1.5)	1 (1.2)
<i>C. holmii</i>	-	1 (1.2)
<i>C. humicola</i>	-	2 (2.5)
<i>C. norvegensis</i>	-	2 (2.5)
<i>C. rugosa</i>	-	1 (1.2)
<i>C. sake</i>	1 (1.5)	-
<i>C. valida</i>	-	1 (1.2)
<i>C. pechellsii</i>	-	3 (3.7)
<i>Rhodotorula</i>	-	1 (1.2)
<i>S. cerevisiae</i>	-	1 (1.2)
<i>Candida</i> spp	4 (6.6)	4 (4.9)
<i>C. albicans</i>	48 (78.5)	47 (58)
non- <i>albicans</i>	13 (21.3)	34 (42)

**Table 4** - Association between oral manifestation and *Candida* species colonization in the group PII.

Oral manifestation	<i>C. albicans</i> n (%)	Non- <i>albicans</i> n (%)	Multiple* n (%)	Negative** n (%)
Absent	15 (28.8)	5 (9.6)	4 (7.6)	4 (7.6)
Candidosis	9 (17.3)	-	11 (21.1)	-
Others	3 (5.7)	-	-	1 (1.9)
Total	27 (51.9)	5 (9.6)	15 (28.8)	5 (9.6)

\*Multiple= *C. albicans* e Non-*albicans* colonization\*\*Negative=not colonized for *Candida* species

**Table 5** - Correlation between immunological category and *Candida* species identified in the PI and PII groups.

Immunological category	<i>C. albicans</i>		Non- <i>albicans</i>	
	PI	PII	PI	PII
	n (%)	n (%)	n (%)	n (%)
<b>1</b>	5 (9.6)	3 (5.7)	1 (1.9)	2 (3.8)
<b>2</b>	21 (40.3)	18 (34.6)	5 (9.6)	7 (13.4)
<b>3</b>	21 (40.3)	21 (40.3)	2 (3.8)	11 (21.1)
<b>Total</b>	47 (90.3)	42 (80.7)	8 (15.3)	20 (38.4)

**Table 6** - Correlation between oral manifestation and immunological category, in Group II (p=0.05, Fisher exact test).

Oral manifestation	Immunological category		
	1 (%)	2 (%)	3 (%)
Absent	3 (5.77)	14 (26.9)	11 (21.1)
Candidosis	0 (0.0)	8 (15.3)	12 (23.0)
Others	2 (3.85)	1 (1.9)	1 (1.9)
Total	5 (9.6)	23 (44.2)	24 (46.1)

**Table 7** - Correlation between oral manifestations associated to HIV-infection and immunomarkers (HIV viral load copies /ml, CD4 and CD8 cells/ml).

Oral Manifestation	n	Viral load <sup>a</sup> Min/ Md / Max***	CD4 <sup>b</sup> Min/Md/Max	CD8 Min/Md/Max
Absent	27	0/14000/1700000	104/861/1870	678/1260/2500
Candidosis	18	3600/52500/330000	76/451/1426	202/1165/2000
Others	3	7000/30000/42000	308/1070/1773	-/1315/-

Mann-Whitney test (p= 0.05)<sup>a</sup> and (p= 0.03)<sup>b</sup>, \*\*\*Minimum/Median/Maximum



**Table 8** - Antifungal susceptibility of *Candida* spp.

Species	MIC <sub>80</sub> range					
	n	AMPH	FLCZ	ITCZ	KTC	MCZ
<i>C. albicans-A</i>	17	2 - 1	2 - 0.25	1 - 0.125	1 - 0.03	32 - 0.5
<i>C. albicans-B</i>	6	8 - 2	64 - 0.125	8 - 0.25	4 - 0.03	32 - 0.5
<i>C. tropicalis</i>	7	1 - 0.03	64 - 0.25	8 - 0.125	8 - 0.03	32 - 2
<i>C. parapsilosis</i>	7	2	2 - 0.25	2 - 0.125	0.5 - 0.03	32 - 8
<i>C. dubliniensis</i>	1	2	0.5	1	0.03	2
<i>C. kefyr</i>	2	2	4 - 0.5	0.5 - 0.125	0.125	2 - 1
<i>C. pechellsii</i>	3	2	2 - 0.25	2 - 1	1 - 0.125	32 - 2
<i>C. stellatoidea</i>	1	2	4	0.125	0.03	1
<i>C. holmii</i>	1	2	4	1	0.06	4
<i>C. valida</i>	1	2	64	2	2	32
<i>C. norvegensis</i>	1	2	32	2	1	16

## Discussion

The frequency of oropharyngeal and oesophageal candidosis has increased dramatically during the past two decades, primarily due to the HIV epidemic. The majority of infections are caused by *Candida albicans*, but recently an increasing number are related to other *Candida* species (80, 81). According to surveillance studies, nosocomial candidemia now is the fourth most common cause of all hospital-acquired bloodstream infections (82). In a study conducted by Pfaller *et al.* (2002) (83) was reported that non-*albicans* species accounted for 46% of all *Candida* bloodstream infections. Non-*albicans* species cause 35-65% of all candidemias in general patient population, but they are less common in children or HIV infected patients (0-33%) (48). Mortality due to non-*albicans* species is similar to *C. albicans*, ranging from 15% to 30% (48).

This study characterized the influence of HIV Protease Inhibitor therapy on the oral *Candida* flora isolated from HIV-infected children (n=52), comparing the identified yeast species before the IP using (GI) and during the IP therapy (GII) in HIV-infected children. There was a statistically significant increase in the incidence of non-*albicans* isolates in group PII relative to PI group (p=0.005 McNemar test). Interestingly 15 children became non-*albicans* carriers after the protease inhibitor treatment. However 3 children were no longer carriers and 5 children remained carriers for non- *albicans* species. This result suggests an important increase of non-*albicans* colonization prevalence in the children after the introduction of protease inhibitor treatment. The higher diversity of the *Candida* species after the introduction of protease inhibitor treatment also has been observed (Table 6). The second most frequent species isolated was *C. tropicalis* (n=9, 17.3%) followed by *C. parapsilosis* (n=8, 15.4%). In contrast Sugizaki *et al.* (84) reported *C. parapsilosis* was the second non-*albicans* species most frequent. The lowest mortality has been associated to *C. parapsilosis* (48). In this study 2 *C. tropicalis* isolates were in the immunological category 1 (p=0.04, Fisher test). *C. tropicalis* is one of the most virulent pathogenic *Candida* species (48, 85), therefore the presence of *C. tropicalis* in HIV-infected children, even in the early HIV disease stages should be monitored. Surprisingly, there were no *C. glabrata* strains isolated, which has previously been shown to be a commonly isolated species (48, 57, 86). The prevalence of *C. dubliniensis* was low

2% when compared with that typically found in Europe (14%) (87). In pediatric cancer patients the non-*albicans* is the most common cause of candidemia (88). Mullen *et al.* reported that *C. tropicalis* was the second species most frequent (89). *Candida* is currently recognized as a major cause of mortality and morbidity in neonatal intensive care units (90).

The prevalence of oral lesions in HIV patients is widely varied in the literature and, depends on the clinical stage of the patient, risk behavior and other factors like education, race, social and economic class and access to health care (91-93). Oropharyngeal candidosis is the most frequent fungal infection in children and adolescents infected with HIV (94, 95). Its clinical manifestations can range from isolated, asymptomatic mucosal plaques to full involvement of the oropharynx and painful mucositis. Oral candidosis may lead to impaired food and fluid intake, weight loss, and dehydration, particularly in infants and young children (95). Although the recovery of immune system that follows HAART use is believed to be the major factor for declining rates of oropharyngeal candidosis, other mechanisms seem to play an essential role as well (16, 53). Recent studies showed that some protease inhibitors can interfere with *Candida* infection by inhibiting the fungal secretory aspartyl proteinases that play a pathogenic role in mucosal invasion (25, 61). In addition, different species of *Candida* show variation on the secretion of aspartyl proteinases patterns (96, 97). In this study, all patients had yeast colonization in the oral cavity, a high prevalence when compared with the healthy population or even non-HIV, commonly 40% to 60% quote. The oral examination was performed only on the PII group. Oral candidosis was found in 38% (n=20) of the patients (Table 4), a similar prevalence to that reported by Ramos-Gomez (43%) (78), and Frezzini *et al.* (22-83%) (93). From the 52 HIV-infected children in this study, 20 (38%) showed oral manifestations associated with *Candida* colonization (Erythematous, pseudomembranous candidosis or cheilites angular), and 28 (53.8%) presented with no visible signs of infection, although 19 of these children were *Candida* carriers. Pseudomembranous candidosis seems to be the most prevalent form in children however erythematous form was the most prevalent (n=9) in this study. Similar results were described previously (98). Only 4 children showed oral lesions not associated with *Candida* infection, although with 3 of these children were *Candida* carriers. Sixteen (57%) out of children who had no *Candida* associated lesions carried *Candida albicans*-A.

And eighteen (90%) out of HIV-infected children with oral candidosis, were *Candida albicans*-A carriers ( $p=0.033$ , Fisher test). Therefore, *Candida albicans*-A should be monitored as a preventive measure against the development of oral lesions. Amongst non-*albicans* isolates, 21% were associated with candidosis. The prevalence of oral candidosis was found to be significantly associated with both HIV load and CD4 cell count, a feature already reported (99-101).

Although the susceptibility of *Candida* to the currently available antifungal agents can be predicted if the species of the infecting isolate is known (68, 79, 102, 103), individual isolates do not necessarily follow the general pattern. The majority of the isolates were susceptible to all antifungal agents tested (Table 8). However one isolate of *C. albicans*-B showed low sensitivity to fluconazole and amphotericin B. Non-*albicans* isolates showed broad range for the antifungal susceptibility. In contrast with previous study that reported resistance in 75% *C. krusei*, 35% *C. glabrata*, 10-25% of *C. tropicalis* and *C. lusitaniae* isolates (48). Assessment of clinical efficacy in patients with oropharyngeal and esophageal candidosis may be confounded by variations in host-response, adherence with antifungal therapy recommendations, usage of concomitant antifungal agents, different antiretroviral regimens, and selective effects of antibiotics administered for concomitant bacterial infections. Despite the high susceptibility to azoles exhibited by the isolates in this study, we found 4.4% ( $n=2$ ) of the strains exhibiting resistance to fluconazole. Most of the isolates in this investigation were susceptible to amphotericin B. Whilst most *Candida* isolates remain susceptible to amphotericin B, recent data suggest that some isolates of *C. glabrata* and *C. krusei* may require maximal doses of amphotericin B (102) to be effective in eliminating the infection. Most of *C. albicans*-A isolates were susceptible against the azoles tested with the exception of miconazole, with 9 *C. albicans*-A strains showing resistance against to miconazole. Amongst *C. albicans*-B isolates ( $n=6$ ) one isolate showed cross-resistance to all azoles tested. The occurrence of azole cross-resistance in clinical *C. albicans* isolates has been demonstrated in HIV-infected adults suffering recurrent oropharyngeal candidosis (104). However, so far few studies have focused on the clinical significance of azole-resistance in pediatric patients. This work shows the emergence of cross-resistance to antifungal azoles in pediatric patients, including azoles not previously used in children.

Amongst non-*albicans* isolates the susceptibility test against azoles indicated that most of isolates were susceptible to the antifungal drugs tested with low and narrow MIC range. However, among *C. tropicalis* isolates (n=7) one isolate was resistant to FLCZ (MIC > 64 µl/ml), one isolate was resistant to ITCZ and KTZ simultaneously, and 2 isolates were resistant to MCZ (MIC > 32 µl/ml). Only one *C. parapsilosis* isolate showed low susceptibility to MCZ (MIC > 32 µl/ml) and 3 other isolates were susceptible-dose dependent (S-DD). In terms of virulence and pathogenicity, some non-*albicans* species appear to exhibit lower virulence in animal models, yet behave with equal or greater virulence in man, when comparison is made with *C. albicans*. Mortality due to non-*albicans* species is similar to *C. albicans*, ranging from 15% to 35% (48). However, there are differences in both overall and attributable mortality among *Candida* species. The lowest mortality is associated with *C. parapsilosis* and the highest with *C. tropicalis* and *C. glabrata* (40-70%). Mortality caused by non-*albicans* species appears to be highest in ITU and surgical patients, although this is somewhat lower in cancer patients, children and HIV-infected patients. Antifungal susceptibility of non-*albicans* species varies significantly in contrast to *C. albicans*. Some non-*albicans* species are inherently or secondarily resistant to fluconazole; for example, 75% of *C. krusei* isolates, 35% of *C. glabrata* and 10-25% of *C. tropicalis* and *C. lusitaniae* isolates (48). Therefore, species directed therapy should be administered for fungaemia according to the species identified. The rare *Candida* species isolated in this study were susceptible to the antifungal agents tested, although the MIC value obtained show significant variability for the non-*albicans* species. An epidemiology study in Brazil by Colombo *et al.* (1999) (80) demonstrated that nosocomial candidemias in tertiary hospitals were caused predominantly by non-*albicans* species, which were rarely fluconazole resistant. In another Brazilian study with HIV-infected adults, *C. albicans*-A isolates were found to be susceptible to fluconazole, itraconazole and ketoconazole (87). These findings underline the importance of standardized susceptibility testing of non-*albicans* species and the development of alternative treatment strategies in pediatric patients.

Differences in *Candida* species prevalence may also have therapeutic implications because less susceptible to fluconazole in species such *C. krusei*, *C. glabrata* and *C. tropicalis* are less frequent in children. The higher diversity species was found in

group PII, including emergence of non-*albicans* species with varied antifungal susceptibility, which suggests a change of *Candida* prevalence after of the inhibitor protease treatment in HIV-infected children. These results can help to understand the natural history of HIV infection in the children and compromising their immunological state in the HAART era. Our study represents the first follow up investigation concerning oral *Candida* flora and antifungal susceptibility in Brazilian HIV-infected children.

## References

1. Krcmery V, Barnes AJ. Non-albicans *Candida* spp. causing fungaemia: pathogenicity and antifungal resistance. *J Hosp Infect.* 2002 Apr;50(4):243-60.
2. Benjamin DK, Jr., Poole C, Steinbach WJ, Rowen JL, Walsh TJ. Neonatal candidemia and end-organ damage: a critical appraisal of the literature using meta-analytic techniques. *Pediatrics.* 2003 Sep;112(3 Pt 1):634-40.
3. Bodey GP, Mardani M, Hanna HA, Boktour M, Abbas J, Girgawy E, et al. The epidemiology of *Candida glabrata* and *Candida albicans* fungemia in immunocompromised patients with cancer. *Am J Med.* 2002 Apr 1;112(5):380-5.
4. Ashman RB, Papadimitriou JM. Production and function of cytokines in natural and acquired immunity to *Candida albicans* infection. *Microbiol Rev.* 1995 Dec; 59(4):646-72.
5. Mencacci A, Spaccapelo R, Del Sero G, Enssle KH, Cassone A, Bistoni F, et al. CD4+ T-helper-cell responses in mice with low-level *Candida albicans* infection. *Infect Immun.* 1996 Dec;64(12):4907-14.
6. Hazen KC. New and emerging yeast pathogens. *Clin Microbiol Rev.* 1995 Oct;8(4):462-78.
7. Sullivan DJ, Henman MC, Moran GP, O'Neill LC, Bennett DE, Shanley DB, et al. Molecular genetic approaches to identification, epidemiology and taxonomy of non-albicans *Candida* species. *J Med Microbiol.* 1996 Jun;44(6):399-408.
8. Pfaller MA, Jones RN, Messer SA, Edmond MB, Wenzel RP. National surveillance of nosocomial blood stream infection due to species of *Candida* other than *Candida albicans*: frequency of occurrence and antifungal susceptibility in the SCOPE Program. SCOPE Participant Group. Surveillance and Control of Pathogens of Epidemiologic. *Diagn Microbiol Infect Dis.* 1998 Feb;30(2):121-9.
9. Melo NR, Taguchi H, Jorge J, Pedro RJ, Almeida OP, Fukushima K, et al. Oral *Candida* flora from Brazilian human immunodeficiency virus-infected patients in the highly active antiretroviral therapy era. *Mem Inst Oswaldo Cruz.* 2004 Jun; 99(4):425-31.

10. Cartledge JD, Midgley J, Gazzard BG. Non-albicans oral candidiasis in HIV-positive patients. *J Antimicrob Chemother.* 1999 Mar;43(3):419-22.
11. Barchiesi F, Morbiducci V, Ancarani F, Scalise G. Emergence of oropharyngeal candidiasis caused by non-albicans species of *Candida* in HIV-infected patients. *Eur J Epidemiol.* 1993 Jul;9(4):455-6.
12. Nguyen MH PJ, Jr., Morris AJ, Tanner DC, Nguyen ML, Snyderman DR et al. The changing face of candidemia: emergence of non-*Candida albicans* species and antifungal resistance. *Am J Med* 1996;100:617-23.
13. Sobel JD, Ohmit SE, Schuman P, Klein RS, Mayer K, Duerr A, et al. The evolution of *Candida* species and fluconazole susceptibility among oral and vaginal isolates recovered from human immunodeficiency virus (HIV)-seropositive and at-risk HIV-seronegative women. *J Infect Dis.* 2001 Jan 15;183(2):286-93.
14. Dronda F, Alonso-Sanz M, Laguna F, Chaves F, Martinez-Suarez JV, Rodriguez-Tudela JL, et al. Mixed oropharyngeal candidiasis due to *Candida albicans* and non-albicans *Candida* strains in HIV-infected patients. *Eur J Clin Microbiol Infect Dis.* 1996 Jun;15(6):446-52.
15. Hoegl L, Thoma-Greber E, Rocken M, Korting HC. Persistent oral candidiasis by non-albicans *Candida* strains including *Candida glabrata* in a human immunodeficiency virus-infected patient observed over a period of 6 years. *Mycoses.* 1998 Sep-Oct;41(7-8):335-8.
16. Korting HC, Schaller M, Eder G, Hamm G, Bohmer U, Hube B. Effects of the human immunodeficiency virus (HIV) proteinase inhibitors saquinavir and indinavir on in vitro activities of secreted aspartyl proteinases of *Candida albicans* isolates from HIV-infected patients. *Antimicrob Agents Chemother.* 1999 Aug;43(8):2038-42.
17. Cassone A, De Bernardis F, Torosantucci A, Tacconelli E, Tumbarello M, Cauda R. In vitro and in vivo anticandidal activity of human immunodeficiency virus protease inhibitors. *J Infect Dis.* 1999 Aug;180(2):448-53.



18. Nho S, Anderson MJ, Moore CB, Denning DW. Species differentiation by internally transcribed spacer PCR and HhaI digestion of fluconazole-resistant *Candida krusei*, *Candida inconspicua*, and *Candida norvegensis* strains. *J Clin Microbiol*. 1997 Apr;35(4):1036-9.
19. Chakrabarti A, Ghosh A, Batra R, Kaushal A, Roy P, Singh H. Antifungal susceptibility pattern of non-albicans *Candida* species & distribution of species isolated from *Candidaemia* cases over a 5 year period. *Indian J Med Res*. 1996 Aug;104:171-6.
20. Collin B, Clancy CJ, Nguyen MH. Antifungal resistance in non- albicans *Candida* species. *Drug Resist Updat*. 1999 Feb;2(1):9-14.
21. Fidel PL, Jr., Vazquez JA, Sobel JD. *Candida glabrata*: review of epidemiology, pathogenesis, and clinical disease with comparison to *C. albicans*. *Clin Microbiol Rev*. 1999 Jan;12(1):80-96.
22. Colombo AL, Perfect J, DiNubile M, Bartizal K, Motyl M, Hicks P, et al. Global distribution and outcomes for *Candida* species causing invasive candidiasis: results from an international randomized double-blind study of caspofungin versus amphotericin B for the treatment of invasive candidiasis. *Eur J Clin Microbiol Infect Dis*. 2003 Aug;22(8):470-4.
23. Migliorati CA, Birman EG, Cury AE. Oropharyngeal candidiasis in HIV-infected patients under treatment with protease inhibitors. *Oral Surg Oral Med Oral Pathol Oral Radiol Endod*. 2004 Sep;98(3):301-10.
24. Tacconelli E, Bertagnolio S, Posteraro B, Tumbarello M, Boccia S, Fadda G, et al. Azole susceptibility patterns and genetic relationship among oral *Candida* strains isolated in the era of highly active antiretroviral therapy. *J Acquir Immune Defic Syndr*. 2002 Sep 1;31(1):38-44.
25. Markowitz M, Saag M, Powderly WG, Hurley AM, Hsu A, Valdes JM, et al. A preliminary study of zidovudine, an inhibitor of HIV-1 protease, to treat HIV-1 infection. *N Engl J Med*. 1995 Dec 7;333(23):1534-9.
26. De Bernardis F, Boccanera M, Rainaldi L, Guerra CE, Quinti I, Cassone A. The secretion of aspartyl proteinase, a virulence enzyme, by isolates of *Candida albicans* from the oral cavity of HIV-infected subjects. *Eur J Epidemiol*. 1992 May;8(3):362-7.

27. Abad-Zapatero C, Goldman R, Muchmore SW, Hutchins C, Stewart K, Navaza J, et al. Structure of a secreted aspartic protease from *C. albicans* complexed with a potent inhibitor: implications for the design of antifungal agents. *Protein Sci.* 1996 Apr;5(4):640-52.
28. Bein M, Schaller M, Korting HC. The secreted aspartic proteinases as a new target in the therapy of candidiasis. *Curr Drug Targets.* 2002 Oct;3(5):351-7.
29. Centers for Disease Control and Prevention (CDC). Revised classification system for HIV infection and expanded surveillance case definition for AIDS among adolescents and adults. *MMWR.* 1993;41:1-19.
30. Beighton D, Ludford R, Clark DT, Brailsford SR, Pankhurst CL, Tinsley GF, et al. Use of CHROMagar *Candida* medium for isolation of yeasts from dental samples. *J Clin Microbiol.* 1995 Nov;33(11):3025-7.
31. Sandven P. Laboratory identification and sensitivity testing of yeast isolates. *Acta Odontol Scand.* 1990 Feb;48(1):27-36.
32. Pindborg JJ, Williams DM. [An update of the classification and of the diagnostic criteria of oral lesions in HIV infection. The European Economic Community (EEC) and the Collaborative Center of the World Health Organization for the Oral Manifestations of HIV Infection]. *Minerva Stomatol.* 1993 May;42(5):223-7.
33. Axell T, Samaranayake LP, Reichart PA, Olsen I. A proposal for reclassification of oral candidiasis. *Oral Surg Oral Med Oral Pathol Oral Radiol Endod.* 1997 Aug;84(2):111-2.
34. Ramos-Gomez FJ, Petru A, Hilton JF, Canchola AJ, Wara D, Greenspan JS. Oral manifestations and dental status in paediatric HIV infection. *Int J Paediatr Dent.* 2000 Mar;10(1):3-11.
35. Sano A, M. M.S. Vilela, I. Takahashi, K. Fukushima, K. Takizawa, M. T. N. Silva, J. Uno, K. Nishimura, M. Miyaji. . Isolation of *Candida dubliniensis* from the oral cavity of an HIV-positive child from Brazil. *Japanese Journal of Medical Mycology.* 2000; 3 (41):57-9.

36. National Committee for Clinical Laboratory Standard. Reference Method for Broth Dilution Antifungal Susceptibility Testing of Yeasts. NCCLS document M27-2A Wayne, Pa. 2002.
37. Colombo AL, Nucci M, Salomao R, Branchini ML, Richtmann R, Derossi A, et al. High rate of non-albicans candidemia in Brazilian tertiary care hospitals. *Diagn Microbiol Infect Dis.* 1999 Aug;34(4):281-6.
38. Redding SW, Kirkpatrick WR, Dib O, Fothergill AW, Rinaldi MG, Patterson TF. The epidemiology of non-albicans *Candida* in oropharyngeal candidiasis in HIV patients. *Spec Care Dentist.* 2000 Sep-Oct;20(5):178-81.
39. Zaoutis TE, Foraker E, McGowan KL, Mortensen J, Campos J, Walsh TJ, et al. Antifungal susceptibility of *Candida* spp. isolated from pediatric patients: A survey of 4 children's hospitals. *Diagn Microbiol Infect Dis.* 2005 Aug;52(4):295-8.
40. Pfaller MA, Diekema DJ, Jones RN, Messer SA, Hollis RJ. Trends in antifungal susceptibility of *Candida* spp. isolated from pediatric and adult patients with bloodstream infections: SENTRY Antimicrobial Surveillance Program, 1997 to 2000. *J Clin Microbiol.* 2002 Mar;40(3):852-6.
41. Sugizaki MF, Rhoden CR, Bombonatti DM, Montelli AC, Martinson ME, Lopes CAM. Prevalence and in vitro antifungal susceptibility of *Candida* spp isolated from clinical specimens in Sao Paulo, Brazil. *Rev Iberoam Micol.* 1998;15:16-8.
42. Zaugg C, Borg-Von Zepelin M, Reichard U, Sanglard D, Monod M. Secreted aspartic proteinase family of *Candida tropicalis*. *Infect Immun.* 2001 Jan;69(1):405-12.
43. Barchiesi F, Spreghini E, Maracci M, Fothergill AW, Baldassarri I, Rinaldi MG, et al. In vitro activities of voriconazole in combination with three other antifungal agents against *Candida glabrata*. *Antimicrob Agents Chemother.* 2004 Sep;48(9):3317-22.
44. Mariano Pde L, Milan EP, da Matta DA, Colombo AL. *Candida dubliniensis* identification in Brazilian yeast stock collection. *Mem Inst Oswaldo Cruz.* 2003 Jun;98(4):533-8.

45. Zaoutis TE, Greves HM, Lautenbach E, Bilker WB, Coffin SE. Risk factors for disseminated candidiasis in children with candidemia. *Pediatr Infect Dis J.* 2004 Jul;23(7):635-41.
46. Mullen CA, Abd El-Baki H, Samir H, Tarrand JJ, Rolston KV. Non-albicans *Candida* is the most common cause of candidemia in pediatric cancer patients. *Support Care Cancer.* 2003 May;11(5):321-5.
47. Brian Smith P, Steinbach WJ, Benjamin DK, Jr. Invasive *Candida* infections in the neonate. *Drug Resist Updat.* 2005 Jun;8(3):147-62.
48. Schoofs AG, Odds FC, Colebunders R, Ieven M, Goossens H. Cross-sectional study of oral *Candida* carriage in a human immunodeficiency virus (HIV)-seropositive population: predisposing factors, epidemiology and antifungal susceptibility. *Mycoses.* 1998 May-Jun;41(5-6):203-11.
49. Ceballos-Salobrena A, Gaitan-Cepeda LA, Ceballos-Garcia L, Lezama-Del Valle D. Oral lesions in HIV/AIDS patients undergoing highly active antiretroviral treatment including protease inhibitors: a new face of oral AIDS? *AIDS Patient Care STDS.* 2000 Dec;14(12):627-35.
50. Frezzini C, Leao JC, Porter S. Current trends of HIV disease of the mouth. *J Oral Pathol Med.* 2005 Oct;34(9):513-31.
51. Chiou CC, Groll AH, Gonzalez CE, Callender D, Venzon D, Pizzo PA, et al. Esophageal candidiasis in pediatric acquired immunodeficiency syndrome: clinical manifestations and risk factors. *Pediatr Infect Dis J.* 2000 Aug;19(8):729-34.
52. Muller FM, Groll AH, Walsh TJ. Current approaches to diagnosis and treatment of fungal infections in children infected with human immunodeficiency virus. *Eur J Pediatr.* 1999 Mar;158(3):187-99.
53. De Bernardis F, Chiani P, Ciccozzi M, Pellegrini G, Ceddia T, D'Offizzi G, et al. Elevated aspartic proteinase secretion and experimental pathogenicity of *Candida albicans* isolates from oral cavities of subjects infected with Human immunodeficiency Virus. *Infection and Immunity.* 1996;64(2)::466-71.

54. Ruchel R, de Bernardis F, Ray TL, Sullivan PA, Cole GT. Candida acid proteinases. *J Med Vet Mycol.* 1992;30 Suppl 1:123-32.
55. Ruchel R, Uhlemann K, Boning B. Secretion of acid proteinases by different species of the genus *Candida*. *Zentralbl Bakteriol Mikrobiol Hyg [A].* 1983;255:537-48.
56. Khongkuntian P, Grote M, Isaratanan W, Piyaworawong S, Reichart PA. Oral manifestations in 45 HIV-positive children from Northern Thailand. *J Oral Pathol Med.* 2001 Oct;30(9):549-52.
57. Margiotta V, Campisi G, Mancuso S, Accurso V, Abbadessa V. HIV infection: oral lesions, CD4+ cell count and viral load in an Italian study population. *J Oral Pathol Med.* 1999 Apr;28(4):173-7.
58. Margiotta V, Campisi G, Mancuso S. Plasma HIV-1 RNA and route of transmission in oral candidiasis and oral hairy leukoplakia. *Oral Dis.* 2000 May;6(3):194-5.
59. Campisi G, Pizzo G, Mancuso S, Margiotta V. Gender differences in human immunodeficiency virus-related oral lesions: an Italian study. *Oral Surg Oral Med Oral Pathol Oral Radiol Endod.* 2001 May;91(5):546-51.
60. Rex JH, Walsh TJ, Sobel JD, Filler SG, Pappas PG, Dismukes WE, et al. Practice guidelines for the treatment of candidiasis. *Infectious Diseases Society of America. Clin Infect Dis.* 2000 Apr;30(4):662-78.
61. Barry AL, Pfaller MA, Brown SD, Espinel-Ingroff A, Ghannoum MA, Knapp C, et al. Quality control limits for broth microdilution susceptibility tests of ten antifungal agents. *J Clin Microbiol.* 2000 Sep;38(9):3457-9.
62. Muller FM, Weig M, Peter J, Walsh TJ. Azole cross-resistance to ketoconazole, fluconazole, itraconazole and voriconazole in clinical *Candida albicans* isolates from HIV-infected children with oropharyngeal candidiasis. *J Antimicrob Chemother.* 2000 Aug;46(2):338-40.

## CAPÍTULO 2

(submetido, ref. FEMSYR 05050088)

### **Antifungal Cross-resistance in an Oral *Candida* Isolate from a Pediatric Patient**

N.R. Melo, <sup>1\*</sup> M.M.S. Vilela, <sup>2</sup> H. Taguchi, <sup>3</sup> V.V.P. Culhari, <sup>2</sup> M. Miyaji, <sup>3</sup> P. Groeneveld, <sup>1</sup>  
A.G.S. Warrilow, <sup>1</sup> N. Manning, <sup>4</sup> D.E. Kelly, <sup>1</sup> and S.L. Kelly <sup>1</sup>

*Swansea Clinical School, University of Wales Swansea, SA2 8PP, Wales, UK,*  
<sup>1</sup> *Center for Investigation in Pediatrics, State University of Campinas Medical School,*  
*13083 970, Campinas, SP, Brazil,* <sup>2</sup> *Research Center for Pathogenic Fungi and Microbial*  
*Toxicoses, Chiba University, 1-8-Inohana, Chuo-ku, Chiba 260-8673, Japan,*  
<sup>3</sup> *Sheffield Children's Hospital, Sheffield S10 2TH, UK,* <sup>4</sup>

Corresponding author. Tel: +44 (01792) 20 56 78 ext. 3223;

Fax: +44 (01792) 51 30 54;

E-mail: [nadjarm@yahoo.com](mailto:nadjarm@yahoo.com)

## Abstract

The objective of this study was to characterise the growth and susceptibility of a *Candida albicans* strain to a range of antifungal drugs and investigate its mechanism of resistance. An oral *Candida* isolate from a child showed high values of MIC<sub>80s</sub> for amphotericin B (8 µg/ml), fluconazole (> 64 µg/ml), miconazole (> 32 µg/ml), ketoconazole (> 16 µg/ml) and itraconazole (> 8 µg/ml). At a concentration of 64 µg/ml, voriconazole and fluconazole caused 85% and 65% inhibition of specific growth rate, respectively. Ritonavir at concentration of 4 µg/ml caused 39% inhibition in the growth rate of the clinical strain. Amphotericin B at 16 µg/ml inhibited 72% growth. Cross-resistance to antifungal azoles and amphotericin, in *Candida albicans* isolate from pediatric patients can therefore occur including azoles not previously used in children. The azole and polyene cross-resistance was not related to a defect of sterol metabolism and indicates new mechanisms of resistance are present in the clinical isolates.

Keywords: HIV1-infected children, *Candida*, cross-resistance, azoles

## 1 - Introduction

The relevance of *Candida* spp. as etiologic agents of *Candida* infection is well established (46). *Candida albicans* is the predominant species accounting for 41-74% of candidemia reported from surveillance studies performed worldwide (105). Immunocompromised patients, particularly with HIV infection, presenting *Candida* infection have led to a dramatic increase in the use of antifungal therapy. Consequently this increase has been accompanied by an accentuated rise in drug-resistant isolates. Azole resistance in *C. albicans*, particularly to fluconazole, has been well documented (106, 107). Resistance to Amphotericin B is rare and remains the first therapy choice in resistant isolates to azoles, but problems with toxicity have restricted the usage of this drug. Several studies have investigated the multiplicity of mechanisms involved in resistance to azole antifungal agents (108-110). The predominant mechanisms involve active efflux pumps for the antifungal agents, target enzyme alterations, and deficiencies in sterol C5-desaturase (111). Nevertheless, cross-resistance between drugs seems to be an emergent problem (104, 105). In consequence, the increased resistance to antifungal agents has led to the development of new antifungal agents with new drug targets. This study documents cross-resistance to antifungal azoles and polyene drugs in a *Candida albicans* isolate from a HIV infected child not previously exposed to azoles.



## 2 - Materials and methods

### 2.1 - Strains

The strains used in this study include *C. albicans* B clinical isolate (1-MAB) obtained from the patient, *C. albicans* ATCC 90028, ATCC 28516 were used as sensitive reference strains and *erg3* fluconazole- and amphotericin- resistant mutant as control.

### 2.2 - Identification

*Candida albicans* isolate (1-MAB) from the oral cavity of a 5-year old HIV 1-infected child was monitored at the Pediatric Immunodeficiency Division, State University of Campinas, Brazil. The child started HIV antiretroviral therapy in 1999 and never received antifungal therapy. The isolates were identified according to the standard technique (75). They were cultured on corn meal agar (Difco, US), supplemented with 1% Tween 80, at 25°C for 7 days for chlamydospore formation. Germ tube formation was carried out in calf serum (Gibco BR, US) at 37°C for 2 to 4 h. Additionally, the isolates were cultured at 30°C for 48 h on chromogenic agar (CHROMagar® - France) (74), and tested with the *Candida* Check kit® (Iatron laboratories, Inc., Japan) and ID32C® profiled (bioMérieux, Marcy l'Etoile, France). Differential growth test at 45°C was used to distinguish *Candida albicans* from *C. dubliniensis*. The isolate was maintained on potato dextrose broth containing 25% glycerol (PDA Difco, MO, USA) at -80°C.

### 2.3 - Antifungal drug susceptibility tests

*Antifungal agents* - Amphotericin B (AMB) (Bristol-Myers Squibb), fluconazole (FLC) (Pfizer Pharm. Inc. Japan), miconazole (MCZ) (Mochida Pharm. Inc. Japan), and itraconazole (ITC) (Janssen-Kyowa Co., Ltd., Japan), were tested against the isolates. Antifungal susceptibility tests were performed using the broth microdilution method according to the guidelines recently published by the National Committee for Clinical Laboratory Standards (NCCLS)(79). *C. albicans* ATCC 90028 and ATCC 28516 were used in each microdilution set as quality control.

#### 2.4 - Growth inhibition studies

*Antifungal agents.* Voriconazole (Pfizer Pharm. Inc. UK), fluconazole (Pfizer Pharm. Inc. UK), itraconazole, ketoconazole (Janssen-Kyowa Co., Ltd., UK), miconazole, econazole, clotrimazole (Sigma, St. Louis, Mo., USA), imidazole (Sigma, St. Louis, Mo., USA), 5-flucytosine (Sigma Chemical Co., Ltd., St. Louis, Mo., USA), amphotericin B, and nystatin (Bristol-Myers Squibb), and ritonavir (Abbott, USA) were tested at concentrations ranging from 0.125 to 64 µg/ml.

Single colonies of *C. albicans* clinical strain were inoculated into 10-ml aliquots of YNB (yeast nitrogen broth, Difco) medium containing 2% glucose. These were incubated at 30°C for 24 h with shaking at 250 rpm. Cells were harvested by centrifugation at 3500 x g for 5 min, at 4°C, washed twice with YNB medium and resuspend in 10 ml YNB medium. Cells densities were adjusted to a final concentration of  $2 \times 10^3$  cells/ml in YNB medium containing 2% glucose. Preparation of antifungal drugs and dilution schemes were performed in accordance with the National Committee for Clinical Laboratory Standards (NCCLS)(79). Microtitre plates were inoculated with the tested strain under different drug regimes. Specific growth rates of isolate was determined in aerobic batch cultures at 37°C, over 48 hours using a Bioscreen C Analyser (112). Growth rates were originally calculated as cells per hour (cells.hour<sup>-1</sup>).

#### 2.5 - Accumulation of [<sup>3</sup>H] fluconazole in *Candida* cells

*Materials.* Chemicals were of analytical grade and were purchased from Sigma (Sigma Chemical Co., St. Louis, Mo., USA). [<sup>3</sup>H] fluconazole (specific radioactivity, 37kBq/mmol) was purchased from Amersham International. Fluconazole non-labelled (FLC) was obtained from Pfizer (Pfizer Pharm. UK).

Accumulation of [<sup>3</sup>H] fluconazole in *Candida* cells was determined by a filter-based assay adapted from Sanglard *et al.* (1995) (113). All experiments were repeated on three separate occasions. Cultures were grown to mid-log phase in YNB containing 2% glucose at 30°C, 200 rpm to a density of  $10^9$  cells per ml. The cells were centrifuged at

4,000 x g for 5 minutes and the pellet resuspended in YNB medium to the original cell density. A total of 20 µl of [<sup>3</sup>H] fluconazole (0.154 kBq), with a specific activity of 37 kBq/mmol, was added to 1 ml of the cell suspension. The cells were incubated at 30°C with shaking at 200 rpm. Samples of 100 µl were withdrawn at fixed time intervals, and mixed with 0.5 ml of cold YNB medium containing 20 µM unlabelled fluconazole placed in a Spin-X nylon membrane microfiltration unit (pore size 0.45 µm - Costar, Cambridge). The cells were isolated by centrifugation at 9,000 rpm for 30 s and then washed with the unlabelled fluconazole-YNB medium three times as described above. Liquid scintillant was added and the radioactivity of the cells measured using a liquid scintillation analyzer (2500 TR-TRI carb, Packard Bioscience Company). In a separate experiment, cells were exposed to a subinhibitory concentration of sodium azide (NaN<sub>3</sub>; 0.01 mM) to indicate whether [<sup>3</sup>H] fluconazole accumulation was an active energy- dependent process (110).

## 2.6 - Sterol analysis

*Materials.* Chemicals were of analytical grade and were purchased from Sigma (Sigma Chemical Co., St. Louis, Mo., USA).

*C. albicans* cells were grown to saturation in YNB medium containing 2% glucose. Cells (10<sup>8</sup> cells/ml) were harvested by centrifugation for 5 min at 3000 g, transferred to glass tubes and resuspended in 5 ml of methanol, 3 ml of 60% KOH and 2 ml of 0.5% (w/v) Pyrogallol dissolved in methanol. Additionally 50 µl of 1 mg/ml cholesterol was added to the control sample. The samples were saponified by heating at 90°C for 2 hours. Sterols were extracted using two 5 ml aliquots of hexane followed by evaporation to dryness with N<sub>2</sub>. The isolated sterol fractions were resuspended in 100 µl of toluene and heated at 60°C for 1 h for silylation with 20 µl of bis (trimethylsilyl) trifluoride (BSTFA). The sterol samples were analyzed by gas chromatography/mass spectrometry using split injections at a ratio of 20:1. Sterol identification was determined by comparison of retention times and mass spectra (111, 114)

### 3 - Results

#### 3.1 - Identification

During a screening to investigate *Candida* colonization and antifungal susceptibility in 60 Brazilian HIV 1- infected children, we isolated *Candida albicans*-B from a 5-year old HIV 1-infected child who acquired HIV vertically has been monitored at the Pediatric Immunodeficiency Outpatient Service, University of Campinas' State, Brazil. The medical history of the patient indicated that the child had never received azole therapy before. The child started started highly active antiretroviral therapy (HAART) in November 1999. In May 2001 the child presented an HIV viral load of 130 000 rep/ml, CD4 lymphocyte count was 1315 cells/ml and CD8 lymphocyte count 1315 cells/ml. The clinical isolate from the child was identified as *C.albicans*-B.

#### 3.2 - Antifungal drug susceptibility tests

Antifungal susceptibility of the *Candida albicans*-B isolate was determined by the microdilution method adopted by the National Committee for Clinical Laboratory Standards(79). The antifungal susceptibility (MIC<sub>80s</sub>) of the *Candida albicans*-B isolate was tested and showed low susceptibility to all antifungal agents tested (Table 1).

#### 3.3 - Growth inhibition studies

To investigate the possible cross-resistance to eleven antifungal drugs and one protease inhibitor and the growth inhibition pattern on this clinical strain, the effect of the several drugs on the specific growth rate was determined in aerobic batch cultures using a Bioscreen C Analyser. Voriconazole, fluconazole, itraconazole, ketoconazole, miconazole, econazole, clotrimazole, imidazole, amphotericin B, nystatin, 5-flucytosine and ritonavir were tested. The *Candida albicans*-B isolate showed cross-resistance to several of the azoles tested (Table 2). We determined the cell growth and inhibition of this isolate in the presence of voriconazole, a recent antifungal agent used in the treatment of recurrent oropharyngeal candidiasis. At concentrations of 64 µg/ml of voriconazole and fluconazole,

the cell growth of the clinical isolate were 15% and 34.6% of the untreated cells, respectively, in contrast to the sensitive strain (ATCC 28516) where growth was totally inhibited (Table 2). Amphotericin B concentrations of 16 µg/ml caused a 72% inhibition in the growth rate of the clinical strain and total inhibition of growth in the sensitive strain. At amphotericin B concentrations of 2 µg/ml, growth of the clinical strain was not inhibited compared to the 19% inhibition observed for the sensitive strain. The *C. albicans*-B clinical isolate gave a growth rate of over 20% at all concentrations tested with most of the antifungal agents, even at high concentrations (> 32 µg/ml). The exceptions were clotrimazole (18.5%), amphotericin B (17%), nystatin (11%) and (Table 2). The breakpoint for 5-flucytosine was 0.25 µg/ml for both the *C. albicans*-B clinical isolate and sensitive-fluconazole strain (ATCC 28516). Ritonavir was four-fold more effective at inhibiting the cell growth of the sensitive-fluconazole strain (ATCC 28516) than the clinical isolate, with inhibition observed at 1 and 4 µg/ml, respectively.

### 3.4 - Accumulation of [<sup>3</sup>H] fluconazole in *Candida* cells

In order to determine if cellular accumulation of fluconazole could be altered in the clinical isolate, cells were incubated in the presence of [<sup>3</sup>H] fluconazole. The isolate was exposed to [<sup>3</sup>H] fluconazole and intracellular fluconazole levels were determined at several time intervals (Table 3). The clinical isolate (1-MAB) and sensitive-fluconazole strains (ATCC 90028 and ATCC 28516) were found to differ in the rate of [<sup>3</sup>H] fluconazole accumulation. The isolate from the HIV-infected child was found to accumulate approximately half the amount of [<sup>3</sup>H] fluconazole ( $44.9 \pm 4.4$ ) than the reference strains (Table 3). [<sup>3</sup>H] fluconazole accumulation in the reference strain (ATCC 90028) was largely unaffected by the presence of sodium azide. However, the *C. albicans* B isolate from the HIV-infected child was found to accumulate approximately 1.5 times more [<sup>3</sup>H] fluconazole in presence of sodium azide. [<sup>3</sup>H] fluconazole accumulation observed in the isolate from the HIV-infected child indicated that the efflux of fluconazole from the strain was an active, energy-dependent process, as sodium azide inhibits ATP formation required for active transport.

### 3.5 - Sterol analysis

Analysis of the sterol profile of the clinical strain in this study revealed that ergosterol was the predominant sterol (Table 4), accounting for 76% of the total sterols and 4-desmethyl sterols (17%). Similar profiles were found for both fluconazole-sensitive strains (ATCC 90028 and ATCC 28516), the ergosterol was the major sterol detected showing 94% and 80%, respectively. In contrast, the resistant strain control (*erg3* fluconazole- and amphotericin- resistant mutant) had a different sterol composition, accumulating ergosta-7,22 dienol (77%), and ergosta-7-enol (22%).

#### 4 - Discussion

The occurrence of azole cross-resistance in clinical *C. albicans* isolates has been demonstrated in HIV-infected adults suffering recurrent oropharyngeal candidiasis (104, 106, 107, 115). However, so far little attention has been paid to the clinical significance of azole-resistance in pediatric patients (104). The oral *Candida* isolate from the child in this investigation showed low susceptibility to all azoles tested as judged in MIC<sub>80</sub>s, fluconazole (> 64 µg/ml), miconazole (> 32 µg/ml), ketoconazole (> 16 µg/ml), and itraconazole (> 8 µg/ml). The clinical isolate also showed low susceptibility to amphotericin B (8 µg/ml). Eleven antifungal drugs and one protease inhibitor were tested to investigate the possible cross-resistance in the clinical isolate. Voriconazole and fluconazole caused 85 % and 65% growth inhibition, respectively, at a concentration of 64 µg/ml. Amphotericin B at concentration of 8 µg/ml inhibited 62% of cell growth. The *C. albicans*-B clinical isolate gave a specific growth rate of over 20% at all concentrations with most of the antifungal agents tested, even at high concentrations (> 32 µg/ml) (Table 2). 5-flucytosine was effective at inhibiting cell growth of the *C. albicans*-B clinical isolate at concentration of 0.25 µg/ml. 5-flucytosine has been successfully used in combination with amphotericin B in the treatment of several deep mycoses (15). 5-flucytosine exhibits a low toxicity in contrast to amphotericin B. The synergistic effect obtained by this drug combination provides an alternative therapy in resistance cases (15, 46, 116, 117). Although we did not test the drug combination, our results suggest that 5-flucytosine may be useful in the treatment of cross-resistant to polyenes and azoles. The literature has attributed the significant reduction of oropharyngeal candidosis in the HIV-infected patients to the direct effect of the antiretroviral protease inhibitors (62). This compound has shown effect on aspartyl protease, which is an important putative virulence factor of *Candida* spp.. Ritonavir, HIV protease inhibitor, has been studied before by Migliorati *et al.* who reported that ritonavir actively effected only part of the positive isolates which secrete aspartyl protease (62, 67, 118). The antifungal effect of the protease inhibitors has been compared to fluconazole (62, 67, 118). However few reports (119) have studied the *Candida* cell growth and susceptibility range *in vitro* of the HIV protease inhibitors. *C. albicans*-B clinical isolate in this study showed low

susceptibility to ritonavir with 39% inhibition at concentration of 4 µg/ml on the other hand the sensitive-fluconazole strain (ATCC 28516) was inhibited 94%. Thus, one could speculate that the long term use of ritonavir, as part of HIV therapy, could influence the virulence of the clinical *Candida* isolate. In spite of the recent findings of the non-conventional unexpected benefit (120) of the protease inhibitors against *C. albicans* secreted aspartyl proteases further studies are needed to establish a possible non-conventional use of the HIV protease inhibitors.

Several resistance mechanisms to the azole and polyene antifungal classes in *C. albicans* have been reported (107, 115, 121). The relevant mechanisms consist of an active efflux pump of the antifungal agents, target enzyme alterations and deficiencies in C5-desaturase (111, 113). The clinical isolate had a similar ergosterol composition to the sensitive strains and previous results (107). But with increased amounts of the sterol intermediates this may well represent an intrinsic difference between the strains unrelated to resistance. Similar profiles have been observed elsewhere (122) and the retention of ergosterol at a high percentage of total sterols does not indicate specific mutation of the enzymes involved in sterol pathway. Amphotericin is believed to interact with ergosterol to mediate fungicidal effects, but no large scale sterol changes of the sort produced by polyene resistance were evident (107, 111).

The accumulation of fluconazole from the clinical isolate, *Candida albicans*-B isolate, was found to be an active process, as the presence of sodium azide caused an increase in the intracellular levels of fluconazole. It is also true that in the sensitive reference strain ATP-dependent pumps are operating, however no effect was observed when sodium azide was added. Thus some evidence supporting resistance of this isolate to antifungal azoles may to be in part due to an active transport efflux mechanism was obtained and this is the most frequent molecular mechanism of azole resistance recently described (106).

Several studies have investigated the multiplicity of mechanisms involved in resistance to azole antifungal agents (108-110), (123) Three *Candida albicans* proteins, namely the ATP-binding cassette (ABC) transporters Cdr1p and Cdr2p, respectively, and the major facilitator protein Mdr1p were shown to be major mediators of azole resistance.



These two super families of active multidrug transporters play an important role in decreasing the intracellular fluconazole concentration of fluconazole-resistant *C.albicans* isolates by active transport. These mechanisms do not give rise to amphotericin cross-resistance hence the novelty of the findings here.

Previously an example of azole and amphotericin cross-resistance not related to a defect in sterol biosynthesis was observed in *Cryptococcus neoformans* mutants isolated *in vitro* (114) and similar mechanisms may be operating in the clinical *C. albicans* studied here. Elucidating these will require molecular analysis.

This study also suggests that the different pattern of voriconazole effect on cell growth in comparison to other azoles, and particularly to fluconazole, may indicate that additional antifungal targets may be involved in the azole resistance. The presence of cross-resistance to antifungal drugs in pediatric patients, including azoles not previously used in children, does therefore occur.

**Table 1** - Drug susceptibilities of the *C.albicans* isolates (1-MAB, ATCC 90028, ATCC 28516, and *erg3* fluconazole-and amphotericin- resistant mutant).

Drug	1-MAB	ATCC 90028	ATCC 28516	<i>Erg3</i>
	Drug concentration (MIC <sub>80S</sub> , µg/ml)			
FLC	≥64	≤1	≤1	≥64
VOR	≤8	≤0.5	≤0.5	≥64
ITC	≥8	≤0.5	≤0.5	≥64
KTZ	≥16	≤1	≤1	≥64
MCZ	≥32	≤1	≤1	≤8
AMB	8	1	2	8

**Table 2** - Effect of antifungal drugs on the percentage on the specific growth rate (cell.h<sup>-1</sup>) of *C. albicans* isolates

Drug	Drug Concentration (µg/ml)																	
	64		32		16		8		4		2		1		0.5		0.25	
	Growth rate (%)																	
	A	S	A	S	A	S	A	S	A	S	A	S	A	S	A	S	A	S
VRC	15.3	0	16	0.7	17.3	2.5	18.7	3.6	19.6	15.3	20.4	19.2	22.3	19.1	46.1	42.7	87.6	43
FLC	34.6	0	36.9	0.7	49.2	2.7	50	3.8	72.3	0.3	72.5	0.5	72.6	85	100	44	100	45
ITC	1.7	0	30.7	0	38.6	0	37.3	0.35	36.3	1.2	44.6	4.2	52	12.2	53.1	37.5	70	68.8
KTC	7	0	31.5	0	30	0	31.5	0	31.5	9.8	57.6	45.6	73.7	62.5	95.3	82.3	99	95
MIC	0	0	21.5	1	41.5	1.5	51.5	4.6	60.7	23	65	50.4	77.4	68.8	77.2	76.6	88	77.4
ECO	8.1	0	26.9	2.5	31.5	8.8	40.7	39	80	69.8	99	90.3	99	95	99	99	99	99
CLT	14	0	18.4	0	30.7	0	35.6	0	38.8	1	40	12.5	87.6	42.2	95.3	56.2	99	58
IM	88	-	100	78.9	100	82.9	100	95.7	100	90.6	100	91.8	100	99	100	99	100	99
AMB	0	0	16.9	0	27.6	0.3	38.4	0.3	45.3	0.3	100	80.7	100	85	100	85	100	88
NYT	0	0	10.7	0	18.4	0	21.5	0	100	81.9	100	100	100	100	100	100	100	100
5FC	0	0	0	0	0	0	0	0	0	0	0.1	0	0.3	0	1.3	1	42	28
RT	1.2	-	4.1	2.3	4.1	2.5	4.6	5.3	61.3	6	63.7	14.5	83.5	35.1	86.2	74	85.6	87

A= 1-MAB, clinical isolate; S= ATCC 28516, sensitive isolate. VRC= Voriconazole, FLC= fluconazole, ITC= itraconazole, KTC= ketoconazole, MIC= miconazole, ECO= econazole, CLT= clotrimazole, IM= imidazole, AMB= amphotericin B, NYT= nystatin, 5FC=5-flucytosine and RT=ritonavir. Growth rate is expressed as percentage of the control without drug.

**Table 3** - Accumulation of [<sup>3</sup>H] fluconazole (dpm/min) in presence of NaN<sub>3</sub> in *C. albicans* clinical isolates (1-MAB).

Strains	[ <sup>3</sup> H] fluconazole (MD ± SD)	[ <sup>3</sup> H] fluconazole + NaN <sub>3</sub> (MD ± SD)
1-MAB	44.9 ± 4.4	117.5 ± 32.8
ATCC 90028 (S)*	80.5 ± 12.8	87.5 ± 31.6
ATCC 28516 (S)*	73.4 ± 6	83 ± 8

\*Fluconazole-sensitive

**Table 4** - Sterol composition of *C. albicans* isolates.

Sterol identified	Total Sterol fraction (%)			
	1-MAB	ATCC 90028	ATCC 28516	<i>erg3</i>
Ergosterol	76	93.7	84.2	-
Ergosta-7,22 dienol	0.15	-	0.6	77
Ergosta-7-enol	0.7	-	-	22
4-desmethyl sterols	17.3	-	3.2	-
4-methyl sterols	5.5	-	6	-
Unidentified	-	6.3	6	1

## References

1. Melo, N. R., Taguchi, H., Jorge, J. *et al.* (2004). Oral *Candida* flora from Brazilian human immunodeficiency virus-infected patients in the highly active antiretroviral therapy era. *Mem Inst Oswaldo Cruz* **99**, 425-431.
2. Swinne, D., Watelle, M., Van der Flaes, M. *et al.* (2004). In vitro activities of voriconazole (UK-109, 496), fluconazole, itraconazole and amphotericin B against 132 non-albicans bloodstream yeast isolates (CANARI study). *Mycoses* **47**, 177-183.
3. Perea, S. (2000). [Azole resistance in *Candida albicans*]. *Rev Esp Quimioter* **13**, 314-317.
4. Kelly, S. L., Lamb, D. C., Kelly, D. E. *et al.* (1997). Resistance to fluconazole and cross-resistance to amphotericin B in *Candida albicans* from AIDS patients caused by defective sterol delta5,6-desaturation. *FEBS Lett* **400**, 80-82.
5. Karababa, M., Coste, A. T., Rognon, B. *et al.* (2004). Comparison of gene expression profiles of *Candida albicans* azole-resistant clinical isolates and laboratory strains exposed to drugs inducing multidrug transporters. *Antimicrob Agents Chemother* **48**, 3064-3079.
6. Perea, S., Fothergill, A. W., Sutton, D. A. *et al.* (2001). Comparison of in vitro activities of voriconazole and five established antifungal agents against different species of dermatophytes using a broth macrodilution method. *J Clin Microbiol* **39**, 385-388.
7. Moran, G. P., Sanglard, D., Donnelly, S. M. *et al.* (1998). Identification and expression of multidrug transporters responsible for fluconazole resistance in *Candida dubliniensis*. *Antimicrob Agents Chemother* **42**, 1819-1830.
8. Jackson, C. J., Lamb, D. C., Manning, N. J. *et al.* (2003). Mutations in *Saccharomyces cerevisiae* sterol C5-desaturase conferring resistance to the CYP51 inhibitor fluconazole. *Biochem Biophys Res Commun* **309**, 999-1004.

9. Muller, F. M., Weig, M., Peter, J. *et al.* (2000). Azole cross-resistance to ketoconazole, fluconazole, itraconazole and voriconazole in clinical *Candida albicans* isolates from HIV-infected children with oropharyngeal candidiasis. *J Antimicrob Chemother* **46**, 338-340.
10. Sandven, P. (1990). Laboratory identification and sensitivity testing of yeast isolates. *Acta Odontol Scand* **48**, 27-36.
11. Beighton, D., Ludford, R., Clark, D. T. *et al.* (1995). Use of CHROMagar *Candida* medium for isolation of yeasts from dental samples. *J Clin Microbiol* **33**, 3025-3027.
12. National Committee for Clinical Laboratory Standard (2002). Reference Method for Broth Dilution Antifungal Susceptibility Testing of Yeasts. *NCCLS document M27-2A*. Wayne, Pa.
13. Groeneveld, P., Rolley, N., Kell, D. B. *et al.* (2002). Metabolic control analysis and engineering of the yeast sterol biosynthetic pathway. *Mol Biol Rep* **29**, 27-29.
14. Sanglard, D., Kuchler, K., Ischer, F. *et al.* (1995). Mechanisms of resistance to azole antifungal agents in *Candida albicans* isolates from AIDS patients involve specific multidrug transporters. *Antimicrob Agents Chemother* **39**, 2378-2386.
15. Joseph-Horne, T., Loeffler, R. S., Hollomon, D. W. *et al.* (1996). Amphotericin B resistant isolates of *Cryptococcus neoformans* without alteration in sterol biosynthesis. *J Med Vet Mycol* **34**, 223-225.
16. Kelly, S. L., Lamb, D. C., Kelly, D. E. *et al.* (1996). Resistance to fluconazole and amphotericin in *Candida albicans* from AIDS patients. *Lancet* **348**, 1523-1524.
17. Gonzalez, C. E., Venzon, D., Lee, S. *et al.* (1996). Risk factors for fungemia in children infected with human immunodeficiency virus: a case-control study. *Clin Infect Dis* **23**, 515-521.
18. Hope, W. W., Taberner, L., Denning, D. W. *et al.* (2004). Molecular mechanisms of primary resistance to flucytosine in *Candida albicans*. *Antimicrob Agents Chemother* **48**, 4377-4386.

19. Martin, E., Parras, P. & Lozano, M. C. (1992). In vitro susceptibility of 245 yeast isolates to amphotericin B, 5-fluorocytosine, ketoconazole, fluconazole and itraconazole. *Chemotherapy* **38**, 335-339.
20. Cassone, A., De Bernardis, F., Torosantucci, A. *et al.* (1999). In vitro and in vivo anticandidal activity of human immunodeficiency virus protease inhibitors. *J Infect Dis* **180**, 448-453.
21. Hood, S., Bonington, A., Evans, J. *et al.* (1998). Reduction in oropharyngeal candidiasis following introduction of protease inhibitors. *Aids* **12**, 447-448.
22. Migliorati, C. A., Birman, E. G. & Cury, A. E. (2004). Oropharyngeal candidiasis in HIV-infected patients under treatment with protease inhibitors. *Oral Surg Oral Med Oral Pathol Oral Radiol Endod* **98**, 301-310.
23. Blanco, M. T., Hurtado, C., Perez-Giraldo, C. *et al.* (2003). Effect of ritonavir and saquinavir on *Candida albicans* growth rate and in vitro activity of aspartyl proteinases. *Med Mycol* **41**, 167-170.
24. Pozio, E. (2004). [Highly Active AntiRetroviral Therapy and opportunistic protozoan infections]. *Parassitologia* **46**, 89-93.
25. Lamb, D. C., Kelly, D. E., White, T. C. *et al.* (2000). The R467K amino acid substitution in *Candida albicans* sterol 14 $\alpha$ -demethylase causes drug resistance through reduced affinity. *Antimicrob Agents Chemother* **44**, 63-67.
26. Venkateswarlu, K., Denning, D. W., Manning, N. J. *et al.* (1995). Resistance to fluconazole in *Candida albicans* from AIDS patients correlated with reduced intracellular accumulation of drug. *FEMS Microbiol Lett* **131**, 337-341.
27. Franz, R., Kelly, S. L., Lamb, D. C. *et al.* (1998). Multiple molecular mechanisms contribute to a stepwise development of fluconazole resistance in clinical *Candida albicans* strains. *Antimicrob Agents Chemother* **42**, 3065-3072.



## CAPÍTULO 3

(aceito para publicação, Brazilian Journal of Microbiology, Ref 009/06)

### ***CANDIDA DUBLINIENSIS* IN A BRAZILIAN FAMILY WITH AN HIV 1- INFECTED CHILD: IDENTIFICATION, ANTIFUNGAL SUSCEPTIBILITY, DRUG ACCUMULATION AND STEROL COMPOSITION**

<sup>†</sup>Nadja Rodrigues de Melo,<sup>1,2</sup> Hideaki Taguchi,<sup>3</sup> Vitoria V. P. Culhari,<sup>2</sup>  
Ayako Sano,<sup>3</sup> Kazutaka Fukushima,<sup>3</sup> Makoto Miyaji,<sup>3</sup> Nigel Manning,<sup>4</sup>  
Steven L. Kelly,<sup>1</sup> and M. Marluce S. Vilela<sup>2</sup>

<sup>1</sup>Center of Pediatric Investigation, Medical School, State University of Campinas,  
Cid. Universitaria, 13083 970 Campinas Brazil, <sup>2</sup>Swansea Clinical School,  
University of Wales Swansea, SA2 8PP Wales UK, <sup>3</sup>Research Center for Pathogenic Fungi  
and Microbial Toxicoses, Chiba University, 1-8-1 Inohana, Chuo-ku, 260-8673  
Chiba Japan and <sup>4</sup>Sheffield Children's Hospital, Sheffield, UK.

<sup>†</sup>Corresponding author: Swansea Clinical School, University of Wales Swansea,  
Grove building Swansea, SA2 8PP Wales UK. Phone: +44 (01792) 205678 ext. 3223.  
Fax: +44 (01792) 513054. E-mail: [nadjarm@yahoo.com](mailto:nadjarm@yahoo.com).

## Abstract

This study investigated the prevalence of *C. dubliniensis* in a Brazilian family with an HIV - infected child. A total of 42 oral isolates were obtained from eight family members. The identification of *C. dubliniensis* was performed by polymerase chain reactions (PCR) using primers against a specific sequence of the *C. dubliniensis* cytochrome *b* gene. Only the HIV-infected child and his grandmother were colonized by *C. dubliniensis*. In this study *C. dubliniensis* isolated from the HIV-infected child exhibited high susceptibility for azoles tested with MIC<sub>80s</sub> of 0.125 and 0.5 µg/ml for voriconazole and fluconazole, respectively. Accumulation of [<sup>3</sup>H] fluconazole in *C. dubliniensis* isolated from the HIV-infected child was slightly reduced in comparison to the reference susceptible strain. *C. dubliniensis* isolates had significantly lower ergosterol levels in comparison to *C. albicans* reference strains.

Key words: *Candida dubliniensis* - antifungal agents - HIV-infected children.

## Resumo

O presente estudo investigou a prevalência de *C. dubliniensis* em uma família brasileira com uma criança infectada pelo vírus HIV. Um total de 42 isolados orais foram obtidos de 8 membros da família. A identificação de *C. dubliniensis* foi realizada por polymerase chain reactions (PCR) usando primers contra a sequência específica para o gene *C. dubliniensis* cytochrome *b*. Apenas a criança infectada pelo vírus HIV e a avó estavam colonizados por *C. dubliniensis*. Neste estudo *C. dubliniensis* isolado da criança infectada pelo vírus HIV exibiu alta susceptibilidade para azoles com concentração mínima inibitória de 0.125 and 0.5 µg/ml para voriconazole and fluconazole respectivamente. Acúmulo de [<sup>3</sup>H] fluconazol intra-celular foi ligeiramente reduzido em *C. dubliniensis* isolado da criança infectada pelo vírus HIV em comparação com a cepa referência sensível ao fluconazole. Isolados de *C. dubliniensis* neste estudo apresentaram níveis significativamente reduzido de ergosterol da membrana celular em comparação com *C. albicans*.

Palavras-chave: *Candida dubliniensis* – agentes antifúngicos - HIV.

## Introduction

*C. dubliniensis* is closely related to *C. albicans* phylogenetically and is found commonly around the world (33, 34). In previous investigations *C. dubliniensis* was isolated from the oral cavities of 27% of human immunodeficiency virus (HIV)-infected subjects and 32% of AIDS patients with oral candidiasis (124, 125). *C. dubliniensis* has also been recovered from the oral cavities of asymptomatic and symptomatic immunocompetent individuals, although to a much lesser extent. *Candida dubliniensis* was first described in South America by Rodero *et al.* (126). Transmission of genetically indistinguishable strains of *C. albicans* between HIV-infected adult partners has been reported previously (95). Little is known about the transmission of *C. dubliniensis* between children and within families (95). The majority of *C. dubliniensis* clinical isolates tested to date are susceptible to several antifungal agents (127). This study investigated the prevalence of *C. dubliniensis* in a Brazilian family with has an HIV - infected child.

## Material and Methods

### *Subjects*

One HIV-infected child who acquired HIV vertically is being monitored at the Pediatric Immunodeficiency Outpatient Service, Medical School, State University of Campinas. The child's parents had deceased from HIV infection disease. The oral flora from the HIV-infected child and his family members were investigated. A total of 42 oral isolates were obtained from eight family members (Table 1).

### *Identification*

All isolates (n=42) were identified according to the standard technique (75). They were primarily cultured at 30°C for 48 hours on chromogenic agar (CHROMagar® - France), (74) prior to growth on corn meal agar (DIFCO, USA), supplemented with 1% tween 80, at 25°C for 7 days for chlamydospore production. Germ tube formation was performed using calf serum (GIBCO BR, USA) at 37°C for 2 to 4 hours. In addition the isolates were tested with *Candida* Check kit® (Iatron laboratories, INC, Japan) (128) and ID32C® analytic profile index strip (bioMerieux, Marcy l'Etoile, France). Differential growth test at 45°C was used to distinguish *Candida albicans* from *C. dubliniensis*. All isolates were stored on potato dextrose broth (PDA Difco, MO, USA) containing 25% glycerol at -80°C and tested for molecular biotyping at a later time.

### *Candida dubliniensis isolates*

*C. dubliniensis* isolates of IFM 48184 (F6583 isolated from a Japanese patient), 48313 (CBS 7978), 48314 (CBS 7988) and 49192 (S-34 isolated from a Brazilian patient) were used as references, and isolates 73 and 390 were obtained from the Brazilian HIV-infected child during 1998 and 1999 (34). The tested isolates were 2-MLA, 3-MLA (grandmother) and 3-LPS (Brazilian HIV-infected child), collected during 2000 and 2001. The Brazilian HIV-infected child received highly active antiretroviral therapy (HAART) including nelfinavir, zidovudina and 3TC. The HIV-infected child received homecare from the grandmother.

### *Confirmation of C. dubliniensis by polymerase chain reactions (PCR)*

The isolates were cultured on potato dextrose agar (PDA Difco, MO, USA) slants at 30°C temperature for 48 hours. Extraction of DNA was performed using a DNA extracting kit; Gen Toru Kun for yeasts (TaKaRa, Ohtsu, Japan). PCR was performed by amplifying a specific sequence of the *C. dubliniensis* cytochrome b gene (34, 129). The primers used were Cdub-F (5'-TTCTCTGTAAGTAATCCTACAATACAGCGT-3') and Cdub-R (5'-ACAATTGATGGAGGTGTCACCATTGGGTTT-3'). A positive result was indicated by the presence of a 305 base product after resolution by electrophoresis in 1% agarose. Comparison of DNA fingerprinting by random amplified polymorphic DNA (RAPD) patterns. The isolates were analyzed by RAPD patterns generated by PCR using 10 pmole of the primer R28M (5'-ATGGATCSSC). An annealing temperature of 35°C was used with Taq DNA polymerase (34, 129).

### *Antifungal susceptibility tests*

MIC<sub>80s</sub> were performed using the broth microdilution method according to the National Committee for Clinical Laboratory Standards (130). Antifungal agents used in this study included amphotericin B (AMPH) (Bristol-Myers Squibb), nystatin (NYS) (Bristol-Myers Squibb), fluconazole (FLCZ) (Pfizer Pharm. Inc. Japan), voriconazole (VOR) (Pfizer Pharm. Inc. UK), miconazole (MCZ) (Mochida Pharm. Inc. Japan), itraconazole (ITCZ) (Janssen-Kyowa Co., Ltd., Japan), ketoconazole (KTZ) (Janssen-Kyowa Co., Ltd., Japan), and clotrimazole (CTZ) (Sigma, St. Louis, Mo., USA).

### *Accumulation of [<sup>3</sup>H] fluconazole in C. dubliniensis isolates*

Accumulation of [<sup>3</sup>H] fluconazole in *Candida* cells was determined by a filter-based assay adapted from Sanglard *et al.* (131). All experiments were repeated on three separate occasions. Overnight cultures were grown in YNB containing 2% glucose at 30°C, 200 rpm to a density of 10<sup>9</sup> cells per ml. The cells were centrifuged at 4,000 rpm for 5 minutes and the pellet resuspended in YNB medium to the original cell density. A total of 20 µl of [<sup>3</sup>H] fluconazole (0.154 kBq), with a specific activity of 37 kBq/mmol, was added to 1 ml of the cell suspension. The cells were incubated at 30°C with shaking at 200 rpm. Samples of 100 µl were withdrawn at fixed time intervals, and mixed with 0.5 ml of cold

YNB medium containing 20  $\mu$ M unlabelled fluconazole placed in a Spin-X nylon membrane microfiltration unit (pore size 0.45  $\mu$ m - Costar, Cambridge). The cells were isolated by centrifugation at 9,000 rpm for 30 s and then washed with the unlabelled fluconazole-YNB medium three times. Liquid scintillant was added and the radioactivity within the cells was measured using a liquid scintillation analyzer (2500 TR-TRI carb, Packard Bioscience Company). In a separated experiment cells were exposed to a subinhibitory concentration of sodium azide ( $\text{NaN}_3$ ; 0.01 mM) (127) to establish whether [ $^3\text{H}$ ] fluconazole accumulation was an active energy- dependent process.

#### *Sterol analysis*

*C. dubliniensis* cells were grown to saturation in YNB medium containing 2% glucose. Cells ( $10^8$  cells/ml) were harvested by centrifugation for 5 min at 3000 rpm, transferred to glass tubes and resuspended in 5 ml of methanol, 3 ml of 60% KOH and 2 ml of 0.5% (w/v) Pyrogalol dissolved in methanol. Additionally 50  $\mu$ l of 1 mg/ml cholesterol was added to the control sample. The samples were saponified by heating at 90°C for 2 hours. Sterols were extracted using two 5 ml aliquots of hexane followed by evaporation to dryness with  $\text{N}_2$ . The isolated sterol fractions were resuspended in 100  $\mu$ l of toluene and heated at 60°C for 1 h for silylation with 20  $\mu$ l of bis (trimethylsilyl) trifluoride (BSTFA). The sterol samples were analyzed by gas chromatography/mass spectrometry using split injections at a ratio of 20:1. Sterol identification was determined by comparison of retention times and mass spectra (111, 114).

## Results and Discussion

HIV-infected patients often suffer severe forms of oropharyngeal candidiasis, mainly caused by *Candida albicans*, although over the last decade the reported incidence of infections caused by other *Candida* species has increased significantly (57). *Candida dubliniensis* is a recently identified yeast, (33, 34, 132) mostly isolated in HIV-infected individuals with oral candidiasis. *C. dubliniensis* has also been recovered from the oral cavities of asymptomatic and symptomatic immunocompetent individuals, although to a much lesser extent. Transmission of genetically indistinguishable strains of *C. albicans* between HIV-infected adult partners has been reported previously (95). However, little is known about the transmission of the isogenic *C. dubliniensis* strain between children and within families. The aim of this study was to investigate the presence of *C. dubliniensis* among Brazilian family members.

*Candida dubliniensis* was first described in South America by Rodero *et al.* (126). Oral flora from one Brazilian HIV-infected child and his family members were investigated. A total of 42 oral mucosa isolates were obtained from eight family members between September 2000 and January 2002 (Table 1). Yeast isolates were identified by classical methods. These included chromogenic agar culture, chlamyospore production, germ tube formation, *Candida* Check kit<sup>®</sup>, ID32C<sup>®</sup> profiled; and the temperature test was also used to distinguish *Candida albicans* from *Candida dubliniensis* by its differential growth at 45°C. The confirmation of *Candida dubliniensis* identification was performed using molecular biotyping. The oral flora of the family members showed high diversity with several non-*albicans* isolates (Fig. 1), particularly the HIV-infected child was carrier of several *Candida* species. *Candida dubliniensis* was isolated only in the HIV-infected child and in his grandmother. The grandmother has repeatedly refused to be HIV tested. The colony formation unit (CFU) quantification was higher for *Candida dubliniensis* (CFU=100) in the HIV-infected child than in his grandmother (CFU <30). No one presented symptomatic oropharyngeal candidiasis at the moment of the oral examination. Higher *Candida* species diversity was observed in the HIV-infected child (Fig. 1).

At the phenotypic level of analysis a number of traits are distinguishable between the majority of *C. albicans* and *C. dubliniensis* isolates (133). However, conclusive differences must be assessed at the genetic level (134). Using the classical identification



methods it was not possible to identify some isolates tested. The primary culture of *Candida* isolates on chromagar showed a dark green colony, rough appearance and smaller size in comparison with *C. albicans* colonies. The tested isolates that were identified as *C.dublinsiensis* by PCR appeared as 305 base pair bands on the gel (Fig.2). The reference isolates had independent band patterns after the RAPD-PCR. Isolates 73, 390, 2-MLA, 3-MLA and 3-LPS had identical RAPD band patterns (Fig.3), indicating that the clinical follow-up of *C.dublinsiensis* might have the same genotype. The other Brazilian *C.dublinsiensis* (S-34) had different genotype. The genotypic coincidence among *C.dublinsiensis* isolates from the same family member revealed that the grandmother was probably contaminated through the HIV-infected child (Fig. 3). Further epidemiological studies for his environment, such as neighbors, classmates and relatives might be requested. Recently Milan and collaborators (135) reported that *Candida* spp. colonization was 33% of the AIDS household contacts in contrast with 14% of the HIV-negative control (135). *C. albicans* was the most frequently isolated species. Our findings also reveal that transmission through the family members is possible and perhaps represents a previously under appreciated factor in families with or without HIV infection. Moreover, the asymptomatic members, who have not received antifungal therapy, may also be colonized with resistant *Candida* species. The transmission of *C.dublinsiensis* among siblings, parents and relatives may be the exchange of contaminated fomites, which commonly occurs in the sharing of food, utensils, and toys.

MIC<sub>80</sub>s for each antifungal agent were determined and all *C. dublinsiensis* isolates investigated were susceptible to the antifungal drugs tested (Table 2), with the exception of nystatin. *C. dublinsiensis* isolates exhibited MIC<sub>80</sub>s values of 0.125 µg/ml for voriconazole. *C. dublinsiensis* isolates from Brazil in a previous study (87) reported high susceptibility for azoles and similar results were described in the literature (125, 127, 136). Non- *dublinsiensis* isolates from the other members of the family were susceptible to all drugs tested (data not shown).

Few studies have reported the sterol composition in *C. dublinsiensis* isolates (136). As it is known enzymes of the ergosterol biosynthetic pathway are important targets of several classes of antifungals used to treat *Candida* infection (107, 111, 115).

In this study sterol profile of *C. dubliniensis* isolates (3-LPS, 2-MLA and IF 48313) showed percentages of 45.4%, 50% and 49.5% of accumulated ergosterol, respectively. In contrast to azole-susceptible *C. dubliniensis* isolates reported in another study in which the ergosterol profile showed 65%, 56% or 60% accumulation (136). *C. dubliniensis* isolates from the Brazilian HIV-infected child (3-LPS) presented several intermediate sterols (Table 4). Interestingly other intermediate sterols were cholesta-8,24-dienol (14%) and ergosta dienol (11%) in the 3-LPS isolate. It has previously been reported that altered membrane composition can affect the function of efflux pumps and susceptibility to azole antifungal agents (107, 115). Sterol composition has been extensively investigated for *C. albicans* but very little is known about the sterol profile in *C. dubliniensis*. In this report *C. dubliniensis* isolates showed a reduced ergosterol level in comparison to *C. albicans* reference strains (ATCC 90028 and 28516). The ergosterol level has shown values up to 80% to both *C. albicans* reference strains (ATCC 90028 and 28516), these results are similar to that described previously (107, 137). The sterol profile in this work suggests an interesting difference between *C. dubliniensis* and *C. albicans*, in regarding that both species are closely related phylogenetically further investigation about the sterol profiles in other *C. dubliniensis* isolates is required.

Additionally because these *C. dubliniensis* clinical isolates showed different ergosterol amount we decide to investigate if the alteration in the function of efflux pumps could be presented in these isolates. To determine if alterations in cellular permeability to fluconazole could be different in both *C. dubliniensis* isolates, from HIV-infected child (3-LPS) and his grandmother (2-MLA), cells were incubated in the presence of [<sup>3</sup>H] fluconazole and the intracellular accumulation of this compound was determined. These isolates were exposed to [<sup>3</sup>H] fluconazole and intracellular fluconazole levels were determined at several time intervals (Fig. 4). The two clinical isolates were found to differ with regard to fluconazole accumulation. The isolate from the HIV-infected child was found to accumulate half the amount of [<sup>3</sup>H] fluconazole than the isolates from grandmother and IF 48313 reference strain (Table 3) however no significant difference. It is also true that in the reference strain (IF 48313 reference strain) ATP-dependent pumps are operating, however no effect was observed when sodium azide was added. However, the isolates from the HIV-infected child and grandmother were found to accumulate

approximately 1.5 times more [<sup>3</sup>H] fluconazole in the presence of sodium azide. [<sup>3</sup>H] fluconazole accumulation observed in the isolates from the HIV-infected child and grandmother indicate that the efflux of fluconazole from these two strains was an active, energy-dependent process, as sodium azide inhibits ATP formation required for active transport. The most frequent molecular mechanism of azole resistance recently described has been the upregulation of efflux pumps (138). Reports have demonstrated resistance in *C. dubliniensis* isolate and its ability to rapidly develop resistance to fluconazole. This characteristic may partially explain the emergence of this species. Several studies have investigated the multiplicity of mechanisms involved in resistance to azole antifungal agents (108, 127, 138). Three *Candida albicans* proteins, namely the ATP-binding cassette (ABC) transporters Cdr1p and Cdr2p, respectively, and the major facilitator protein Mdr1p were shown to be major mediators of azole resistance. These two super families of active multidrug transporters play an important role in decreasing the intracellular fluconazole concentration of fluconazole-resistant *C.albicans* isolates by a mechanism of active drug efflux pump. Drug-efflux-mediated resistance mechanisms in yeasts provide a further therapeutic target for the future. Therefore the differences in the membrane sterol composition may influence the basic biology of these two closely related species, including virulence factors and antifungal drug targets, which requires further investigation.

The acquisition of *C.dubliniensis* and resistant strains by an asymptomatic HIV-infected patient has important clinical implications (36) and may result in the new presentation of oral candidiasis refractory to initial azole therapy. Therefore risks for intrafamilial transmission should be included in infection control programs.

## **Acknowledgements**

This work was supported by Japan International Cooperation Agency (JICA), Center for Investigation in Pediatrics (CIPED), Medical School, State University of Campinas, São Paulo, Brazil. Dr Andrew Warrilow, Swansea Clinical School, University of Wales for proof-reading of this article.

## References

1. Beighton D.; Ludford R.; Clark D.T.; Bailsford S.R.; Pankhurst C.L., et al. Use of CHROMagar Candida medium for isolation of yeasts from dental samples. *J Clin Microbiol* 33: 3025, 1995.
2. Biswas S.K.; Yokohama K.; Wang L.; Nishimura K.; Miyaji M. Identification of *Candida dubliniensis* based on the specific amplification of mitochondrial cytochrome b gene. *Nippon Ishinkin Gakkai Zasshi* 42(2): 95, 2001.
3. Buurman E.T.; Blodgett A.E.; Hull K.G.; Carcanague D. Pyridines and pyrimidines mediating activity against an efflux-negative strain of *Candida albicans* through putative inhibition of lanosterol demethylase. *Antimicrob Agents Chemother* 48: 313, 2004.
4. Coleman D.C.; Sullivan D.J.; Bennett D.E.; Moran G.P.; Barry H.J.; Shanley DB. Candidiasis: the emergence of a novel species, *Candida dubliniensis*. *Aids* 11: 557, 1997.
5. Jackson C.J.; Lamb D.C.; Manning N.J.; Kelly D.E.; Kelly S.L. Mutations in *Saccharomyces cerevisiae* sterol C5-desaturase conferring resistance to the CYP51 inhibitor fluconazole. *Biochem Biophys Res Commun* 309: 999, 2003.
6. Joseph-Horne T.; Loeffler R.S.; Hollomon D.W.; Kelly S.L. Amphotericin B resistant isolates of *Cryptococcus neoformans* without alteration in sterol biosynthesis. *J Med Vet Mycol* 34: 223, 1996.
7. Karababa M.; Coste A.T.; Rognon B.; Bille J.; Sanglard D. Comparison of gene expression profiles of *Candida albicans* azole-resistant clinical isolates and laboratory strains exposed to drugs inducing multidrug transporters. *Antimicrob Agents Chemother* 48: 3064, 2004.
8. Kelly S.L.; Lamb D.C.; Kelly D.E.; Loeffler J.; Einsele H. Resistance to fluconazole and amphotericin in *Candida albicans* from AIDS patients. *Lancet* 348: 1523, 1996.
9. Kelly S.L.; Lamb D.C.; Kelly D.E.; Manning N.J.; Loeffler J.; et al. Resistance to fluconazole and cross-resistance to amphotericin B in *Candida albicans* from AIDS patients caused by defective sterol delta5,6-desaturation. *FEBS Lett* 400: 80, 1997.

10. Mariano Pde L.; Milan E.P.; da Matta D.A.; Colombo A.L. *Candida dubliniensis* identification in Brazilian yeast stock collection. *Mem Inst Oswaldo Cruz* 98: 533, 2003.
11. Milan E.P.; de Laet Sant' Ana P.; de Azevedo Melo A.S.; Sullivan D.J.; Coleman D.C., et al. Multicenter prospective surveillance of oral *Candida dubliniensis* among adult Brazilian human immunodeficiency virus-positive and AIDS patients. *Diagn Microbiol Infect Dis* 41: 29, 2001.
12. Milan E.P.; Kallas E.G.; Costa P.R.; da Matta D.A.; Lopes Colombo A. Oral colonization by *Candida* spp. among AIDS household contacts. *Mycoses* 44: 273, 2001.
13. Moran G.P.; Sullivan D.J.; Henman M.C.; McCreary C.E.; Harrington B.J.; et al. Antifungal drug susceptibilities of oral *Candida dubliniensis* isolates from human immunodeficiency virus (HIV)-infected and non-HIV-infected subjects and generation of stable fluconazole-resistant derivatives in vitro. *Antimicrob Agents Chemother* 41: 617, 1997.
14. Muller F.M.; Groll A.H.; Walsh T.J. Current approaches to diagnosis and treatment of fungal infections in children infected with human immunodeficiency virus. *Eur J Pediatr* 158: 187, 1999.
15. National Committee for Clinical Laboratory Standards (NCCLS). National Committee for Clinical Laboratory Standards. *Reference method for broth dilution antifungal susceptibility testing of yeasts; approved standard. NCCLS document M27-A. Wayne, Pa, 1997.*
16. Nguyen M.H.P.J.; Jr., Morris A.J.; Tanner D.C.; Nguyen M.L.; Snyderman D.R. et al. The changing face of candidemia: emergence of non-*Candida albicans* species and antifungal resistance. *Am J Med* 100: 617, 1996.
17. Perea S.; Lopez-Ribot J.L.; Kirkpatrick W.R.; McAtee R.K.; Santillan R.A.; et al. Prevalence of molecular mechanisms of resistance to azole antifungal agents in *Candida albicans* strains displaying high-level fluconazole resistance isolated from human immunodeficiency virus-infected patients. *Antimicrob Agents Chemother* 45: 2676, 2001.
18. Pfaller M.A.; Messer S.A.; Gee S.; Joly S.; Pujol C.; et al. In vitro susceptibilities of *Candida dubliniensis* isolates tested against the new triazole and echinocandin antifungal agents. *J Clin Microbiol* 37: 870, 1999.

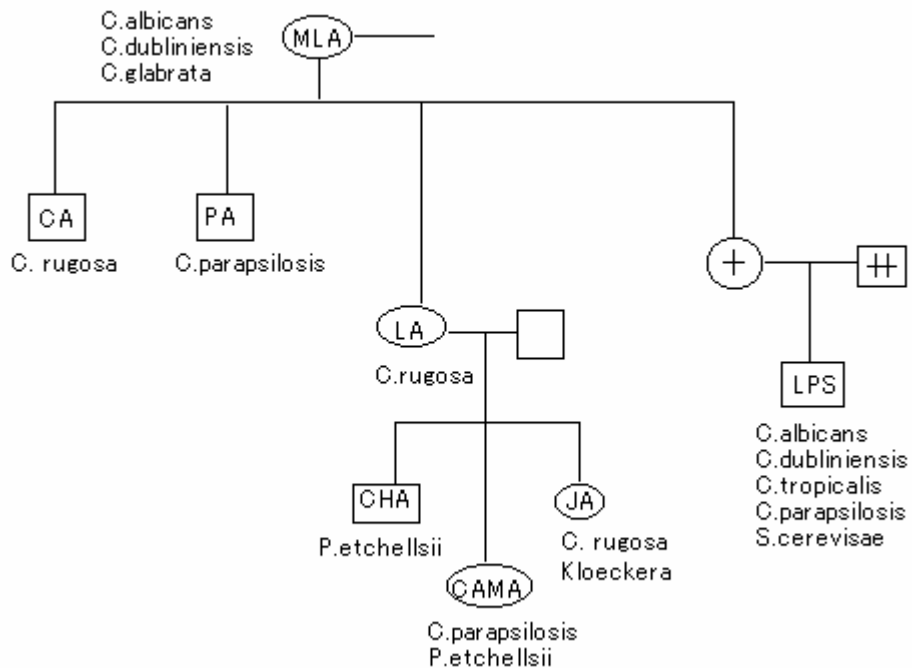
19. Pinjon E.; Moran G.P.; Jackson C.J.; Kelly S.L.; Sanglard D.; et al. Molecular mechanisms of itraconazole resistance in *Candida dubliniensis*. *Antimicrob Agents Chemother* 47: 2424, 2003.
20. Rodero L.; Losso M.; Canteros C.; Hochenfellner F.; Davel G. [Candida dubliniensis: 1st isolation in Argentina]. *Rev Argent Microbiol* 30: 39, 1998.
21. Sandven P. Laboratory identification and sensitivity testing of yeast isolates. *Acta Odontol Scand* 48: 27, 1990.
22. Sanglard D.; Kuchler K.; Ischer F.; Pagani J.L.; Monod M.; Bille J. Mechanisms of resistance to azole antifungal agents in *Candida albicans* isolates from AIDS patients involve specific multidrug transporters. *J. Antimicrob Agents Chemother* 39: 2378, 1995.
23. Sano A.; Vilela M.M.; Takahashi I.; Fukushima K.; Takizawa K.; et al. Isolation of *Candida dubliniensis* from the oral cavity of an HIV-positive child in Brazil. *Nippon Ishinkin Gakkai Zasshi* 41: 177, 2000.
24. Schorling S.R.; Kortinga H.C.; Froschb M.; Muhlschlegel F.A. The role of *Candida dubliniensis* in oral candidiasis in human immunodeficiency virus-infected individuals. *Crit Rev Microbiol* 26: 59, 2000.
25. Soll DR. High-frequency switching in *Candida albicans*. *Clin Microbiol Rev* 5: 183, 1992.
26. Sullivan D.J.; Westerneng T.J.; Haynes K.A.; Bennett D.E; Coleman D.C. *Candida dubliniensis* sp. nov.: phenotypic and molecular characterization of a novel species associated with oral candidiasis in HIV-infected individuals. *Microbiology* 141 ( Pt 7): 1507, 1995.
27. Sullivan S.; Coleman D. *Candida dubliniensis*: characteristics and identification. *J Clin Microbiol* 36, 1998.
28. Tsuchiya T. Serological characterization. . *Methods Microbiol* 16: 26, 1980.
29. Vilela M.M.; Kamei K.; Sano A.; Tanaka R.; Uno J.; et al. Pathogenicity and virulence of *Candida dubliniensis*: comparison with *C. albicans*. *Med Mycol* 40: 249, 2002.

**Table 1** - Characteristics of the eight family members with an HIV-infected child

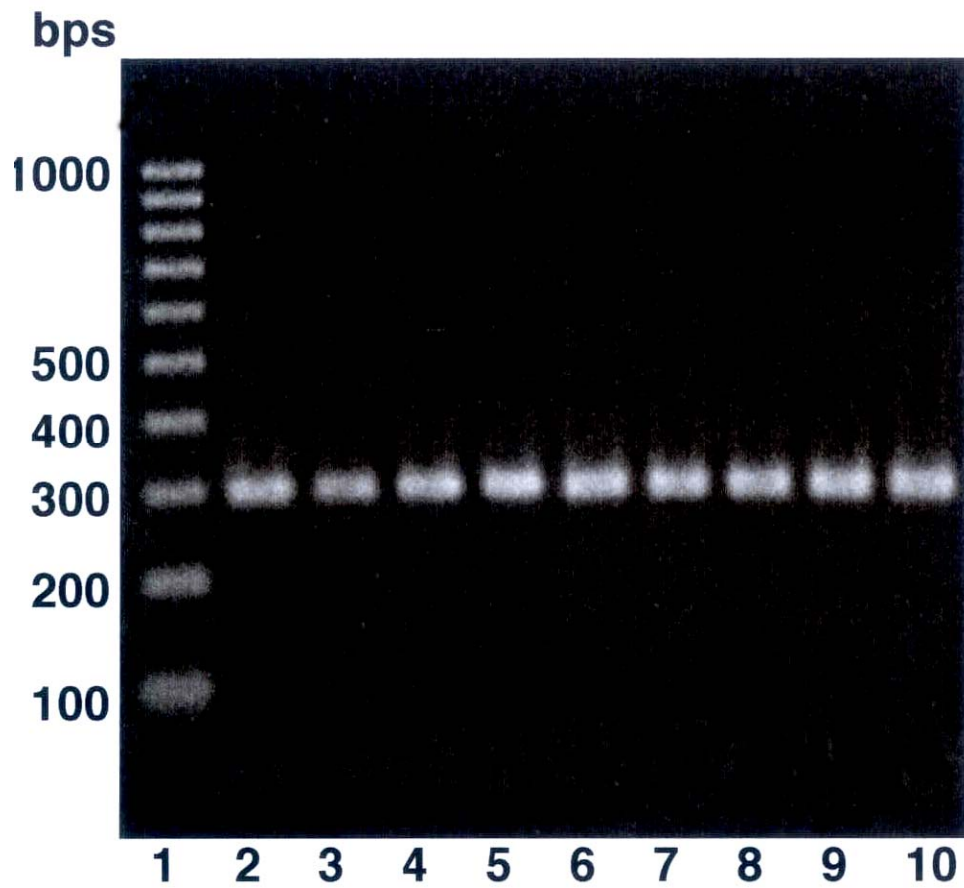
<b>Name</b>	<b>Kindred</b>	<b>Age (years)</b>	<b>Race</b>	<b>Gender</b>
LPS	HIV child	5	white	Male
MLA	grandmother	55	white	Female
LA	aunt	25	white	Female
PA	uncle	20	white	Male
CA	uncle	21	white	Male
CHA	cousin	2	white	Male
CAMA	cousin	7 <sup>a</sup>	white	Female
JA	cousin	6	mulatto	Female

<sup>a</sup>months

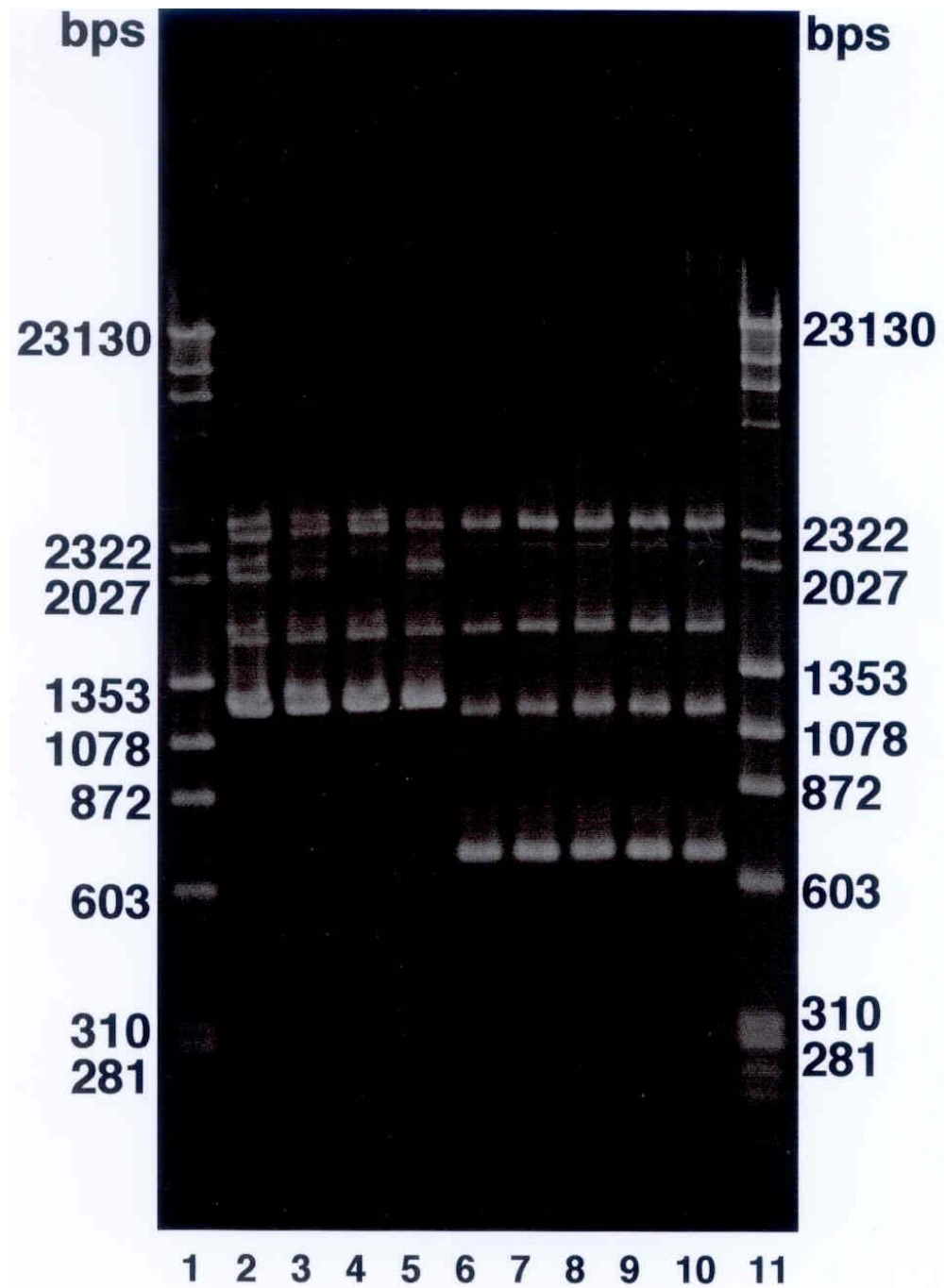




**Fig. 1** - Diagram of the species identified amongst the isolates from the family members of the HIV-infected child. □ LPS (HIV-infected child); + (HIV-infected mother) and ++ (HIV-infected father) both are deceased. Kindred of the HIV-infected child (MLA, CA, PA, LA, CHA, JA and CAMA).



**Fig. 2** - The gel image of amplification of *C.dubliniensis* specific gene in cytochrome *b*. Marker, 1 line; 2, IFM 48184; 3, IFM 48313; 4, IFM 48314; 5, IFM 49192; 6, 73; 7, 390; 8, 2-MLA; 9, 3-MLA; and 10, 3-LPS.



**Fig. 3** - The gel image of RAPD fingerprinting patterns of *C.dubliniensis* isolates. 1, marker; 2, IFM 48184; 3, IFM 48313; 4, IFM 48314; 5, IFM 49192; 6, 73; 7, 390; 8, 2-MLA; 9, 3-MLA; 10, 3-LPS; and 11, marker.

**Table 2** - MICs for antifungal drugs in *C. dubliniensis* isolates

Drug	3-LPS	2-MLA	IFM 48313
	MIC ( $\mu\text{g/ml}$ )		
VOR	0.125	0.125	0.125
FLCZ	0.5	0.125	0.25
ITCZ	1	1	0.125
KTZ	0.03	0.03	0.03
MCZ	2	2	2
CLTZ	0.06	0.06	0.06
AMPH	2	2	2
NYS	16	4	8

**Table 3** - Accumulation of [<sup>3</sup>H] fluconazole (dpm/min) in presence of NaN<sub>3</sub> in clinical *C. dubliniensis* isolates

Strains	[ <sup>3</sup> H] fluconazole (MD ± SD)	[ <sup>3</sup> H] fluconazole + NaN <sub>3</sub> (MD ± SD)
3-LPS	46 ± 11.5	70.3 ± 20.7
2-MLA	94.6 ± 26.1	179.4 ± 64.7
IFM 48313	96.2 ± 17.5	107.7 ± 45.5

**Table 4** - Sterol profile of *C. dubliniensis* clinical isolates (3-LPS, 2-MLA)

Sterol Profile	Total sterol fraction (%)				
	3-LPS	2-MLA	IFM <sup>a</sup> 48313	ATCC <sup>b</sup> 90028	ATCC <sup>b</sup> 28516
Cholesta-8,24-dienol	14	13.1	19.1	-	4
Ergosterol	45.4	50	49.5	93.7	80.2
Ergosta-7,22-dienol	3.4	2.8	3.7	-	0.6
Ergosta-dienol	10.9	10.4	9.6	-	3.7
Methylfecosterol	1.5	-	1.8	-	3
Obtusifoliol	4.7	5.6	6.1	-	2.5
Eburicol	0.3	-	-	-	
4,4-dimethylcholesta-dienol	6.6	5.8	-	-	
Unidentified	12.3	12.3	9.6	6.3	6

<sup>a</sup>*C. dubliniensis* and <sup>b</sup>*C. albicans* reference strains

## CAPÍTULO 4

(aceito para publicação, Brazilian Journal of Microbiology, Ref 178/05)

### **HIV-1 Anti-retroviral Drug Effect on the Growth Rate of *C. albicans* Single Hyphal by a Bio-Cell Tracer System**

Nadja Rodrigues de Melo <sup>1\*</sup>, M Marluce S. Vilela, Jacks Jorge J,<sup>3</sup> Katsuhiko Kamei,  
Makoto Miyaji, Kazutaka Fukushima, Kazuko Nishimura <sup>2</sup>, Philip Groeneveld,  
Steven L. Kelly <sup>1</sup>, Hideaki Taguchi <sup>2</sup>

<sup>1</sup>Swansea Clinical School, University of Wales Swansea, SA2 8PP Swansea UK

<sup>2</sup>Research Center for Pathogenic Fungi and Microbial Toxicoses Chiba University,  
1-8-1 Inohana, Chuo-ku, Chiba 260-8673, Japan, <sup>3</sup>Dental and Medical Sciences Faculty,  
State University of Campinas, Cid. Universitaria, 13083 970 Campinas Brazil

\*Corresponding author. Swansea Clinical School, University of Wales Swansea,  
Grove building Swansea, SA2 8PP Wales UK. Phone: +44 (01792) 205678 ext. 3223.

Fax: +44 (01792) 513054. Email: [nadjarm@yahoo.com](mailto:nadjarm@yahoo.com)

## **Abstract**

Declining incidence of oropharyngeal candidoses and opportunistic infections over recent years can be attributed to the use of highly active anti-retroviral therapy (HAART). Infection with *C. albicans* generally involves adherence and colonization of superficial tissues. During this process, budding yeasts are able to transform to hyphae and penetrate into the deep tissue. Using the biocell tracer system, hyphal growth of *C. albicans* was dynamically observed at the cellular level. Ritonavir was effective in the inhibition of hyphal growth with growth rate of 0.8  $\mu\text{m}/\text{min}$ . This study showed the effect *in vitro* of HIV anti-retroviral drug on the growth rate of the *C. albicans* single hyphae.

Keywords: *Candida*, hyphal, protease inhibitor



Efeito da droga Anti-retroviral HIV-1 no Crescimento de Hifas de *C. albicans* monitoradas pelo sistema Bio cell tracer

## Resumo

Declínio na incidência de candidose orofaríngea e infecções oportunistas associadas a infecção HIV tem sido atribuído a introdução da terapia antiretroviral combinada (HAART). Infecção por *C. albicans* envolve aderência e colonização da mucosa superficial. Durante este processo leveduras são capazes de transformar-se na forma de hifas e penetrar nos tecidos mais profundos. Usando o sistema biocell tracer, crescimento de hifas de *C. albicans* foi observado dinamicamente a nível celular. Ritonavir, inibidor de protease HIV, foi efetivo na inibição do crescimento de hifas com média de 0.8  $\mu\text{m}/\text{min}$ . O presente estudo demonstrou o efeito *in vitro* de um agente antiretroviral-HIV sobre o crescimento de hifas de *C. albicans*.

Palavras-chave: *Candida*, hifa, inibidor de protease

## Introduction

Oropharyngeal candidoses is a frequent opportunistic mycosis in immunocompromised patients. The main causative agent of this infection is *C. albicans*. (139) *C. albicans* is a dimorphic fungus with ability to transform between yeast and hyphal cells. Both forms are invariably present in lesions. Evidence suggests that the mycelial form is important in the pathogenesis of candidoses.(139) Putative virulence factors of *C. albicans* include cell wall adhesions, phenotypic switching, hyphal formation, thigmotropism and secretion of proteases and others hydrolytic enzymes.(140) Production of extracellular proteases in *Candida* was first reported by Staib (1969).(141) *C. albicans* has the ability to secrete proteases facilitating the invasion of mucosal tissue.(142) Declining incidence of oropharyngeal candidoses and opportunistic infections over recent years can be attributed to the use of highly active anti-retroviral therapy (HAART), including HIV protease inhibitor (PI), in the treatment of HIV-infected patients. (46, 61, 62, 143) This has been attributed to *Candida* proteases belonging the same protease class as HIV protease. Recent studies suggest a correlation exist between high protease secretion and reduced susceptibility to some azoles by *C. albicans* isolates from HIV-infected patients before HAART. (24, 119, 144, 145) Kretschmar *et al.* (1999) (146) demonstrated that both germ tubes and protease activity correlated with tissue damage in *C. albicans* infection. However little is known about the effect of HIV protease inhibitor on *Candida* hyphal growth. The main treatment of *Candida* infections has been based on azole and polyene therapy (147). Azoles have also been showed to interfere with respiration process, inhibition of the hyphal formation and activity of membrane-bound enzymes.(148) This study investigated the effect of an HIV protease inhibitor on the growth rate of *Candida* single hyphal by a bio-cell tracer system.

## Material and Methods

*Organism.* *C. albicans* ATCC 90028 reference strain.

### *Materials*

Amphotericin B (AMB) (Bristol-Myers Squibb), reagent grade was dissolved in dimethyl sulfoxide solvent (DMSO). Ritonavir (RT) (Abbott Co., UK) was dissolved in methanol. Other chemicals used included poly-L-lysine (Sigma Chemical Co., Ltda., St. Louis, Mo., USA), fetal calf serum 5% (GIBCO, Laboratories), and RPMI-1640 medium (Nissui Pharmaceutical Co., Japan) which was buffered with morpholinepropanesulfonic acid (MOPS; Sigma Chemical Co.).

### *Antifungal Susceptibility Test*

To determine the MIC of the strain, antifungal susceptibility tests were performed as previously described by the National Committee for Clinical Laboratory Standards (NCCLS 1997).(149)

### *Cellular yeast growth*

Ritonavir and amphotericin B were tested at concentration ranging from 0.125 to 64 µg/ml. Single colonies of *C. albicans* ATCC 90028 strain was inoculated into 10-ml aliquots of YNB (yeast nitrogen broth, Difco) medium containing 2% glucose. These were incubated at 30°C for 24 h with shaking at 250 rpm. Cells were harvested by centrifugation at 3500 rpm for 5 min, at 4°C, washed twice with YNB medium and resuspend in 10 ml YNB medium. Cells densities were adjusted spectrophotometrically to an optical density (OD<sub>600</sub>) with value of 0.42 at 600 nm and then diluted to a final concentration of  $2 \times 10^3$  cells/ml in YNB medium containing 2% glucose. Preparation of antifungal drugs and dilution schemes were performed in accordance with the National Committee for Clinical Laboratory Standards (NCCLS, 1997). Specific growth rates (cells.h<sup>-1</sup>) of the strain were determined in aerobic batch cultures at 37°C, 48 h using a Bioscreen C Analyser.(112)

### *Monitoring of single hyphal growth by the Biocell-Tracer system*

Cells were pre-cultured in RPMI-1640 medium at 37°C with shaking at 150 rpm for 24h. Cells were washed 3 times with saline solution by centrifugation at 2000 rpm and cell count adjusted to approximately  $1 \times 10^6$  cells/ml. Plastic tissue culture dishes (35 x 10 mm, Nunc, Denmark) were used as culture vessels. The inner surface of this vessel was covered with 0.01% poly-L-lysine. Cells suspension (1 ml) was inoculated onto the culture vessel and kept for 1 hour at room temperature. Using this procedure, cells not adhered to the poly-L-lysine on culture dishes were removed and 1 ml RPMI 1640 supplemented with 5% fetal calf serum was added. The culture vessel was set on the microscope chamber stage at 35°C to get up to 90% hyphal growth. Fifteen to twenty hyphal tips were selected and monitored by the biocell tracer system (BCT, Hidan Co., Ltd, Chiba Japan). This automatic system consists of a microscope (Olympus;IMT-2) and a digital image analyser (Flovel) using a computer program that traces individual hyphal tips. The analytical precision was  $0.01 \mu\text{m}\cdot\text{min}^{-1}$ . The apparatus can trace growing hyphal tips at speeds in the range of 0.5 to  $20 \mu\text{m}\cdot\text{min}^{-1}$ . Growth rates of hyphal tips were measured for 10 min intervals. After stable growth, approximately 1 hour, the medium from the culture vessel was removed and fresh RPMI medium containing the drug to be tested was added or control no drug added. The drugs were tested in separate sets in which AMB was used at concentration of  $\frac{1}{4}$  MIC,  $0.0125 \mu\text{g}/\text{ml}$ , and Ritonavir at concentration of  $58 \mu\text{g}/\text{ml}$ . The growth rate was monitored for 2-4 h.

## **Results and Discussion**

Protease inhibitors (PI) caused a revolution in treating HIV infection when they were introduced in 1996. The introduction of highly active antiretroviral therapy (HAART) including PI has been accompanied by a reduction in the frequency of many of the secondary infections caused by HIV infection, including oral lesions.(143, 150-153) Infection with *C. albicans* generally involves adherence and colonization of superficial tissues.(142, 146, 154) During this process, budding yeast cells are able to transform to hyphae and penetrate into the deep tissue.(155)

In the present study the antifungal susceptibility tests for the ATCC 90028 strain gave a MIC to AMB of 1 µg/ml. The effect of the drugs on the yeast growth rate (cells.h<sup>-1</sup>) of the ATCC 90028 strain was determined in aerobic batch cultures using a Bioscreen C Analyser. Ritonavir and amphotericin B were tested at concentration ranging from 0.125 to 64 µg/ml (Fig. 1). AMB inhibited 80% of growth at a concentration of 1µg/ml and was fungicidal at a concentration >1µg/ml (Fig. 1). In contrast Ritonavir showed a progressive inhibitory effect on the yeast growth rate at higher concentrations, inhibiting 85% of the cell growth at concentrations of 2 µg/ml. However, at concentrations of 64 µg/ml, Ritonavir was not fungicide.

Ritonavir shows mean maximum concentrations in serum ( $C_{maxS}$ ) of 0.058 mg/ml after oral administration doses of 100 mg/day. Using the BCT system, cell culture after 1h showed up to 90% hyphal growth then the hyphal tips were exposed to 58 µg/ml of ritonavir. Figures 2 to 4 show time measurement in minutes and the growth rate (µm.min<sup>-1</sup>) of single hyphae. In the post-exposure period the hyphal growth rate in the presence of Ritonavir was  $0.8 \pm 0.33$  µm/min. In contrast AMB at a subinhibitory concentration (0.125 µg/ml) caused only a slight reduction in hyphal growth (Fig. 2) with a growth rate of  $2.8 \pm 0.6$  µm/min. The mean growth rate of the untreated hyphae was constant at approximately 2.5 µm/min at 37°C. Therefore the hyphal growth was progressively reduced after the Ritonavir had been added, indicating hyphal sensitivity to Ritonavir. Several antifungal susceptibility tests such as microdilution (NCCLS), agar diffusion (156) and flow cytometry are designed to work primarily with yeasts and yeast-like fungi. However, for filamentous fungi or hyphal invasion, these standard antifungal susceptibility tests do not accurately determine the effectiveness of a drug as an antifungal agent.

The main treatment of *Candida* infections has been based on azole and polyene therapy.(147) Although amphotericin B shows high toxicity, it is still the drug of choice for systemic mycosis. Amphotericin B act at the level of ergosterol by binding to this molecule. Azoles such as fluconazole, itraconazole or voriconazole inhibit the cytochrome P450 responsible for the 14α demethylation of lanosterol (CYP51) and thus block ergosterol biosynthesis. Inhibition of ergosterol biosynthesis in *C. albicans* causes a variety of functional alterations in the cell membrane such as permeability changes, leakiness and

disruptive interactions with non-sterol and lipid components. Ergosterol biosynthesis is more sensitive to azoles in mycelial cultures than yeast cultures, and this observation has been used to justify the efficacy of azoles *in vivo*.(142, 157, 158)

Recent studies *in vitro* suggest that HIV- protease inhibitors cause inhibition of growth with *Pneumocystis carinii*, (150) *Candida albicans*, (62) and *Toxoplasma gondii*. (153) Indinavir caused an insignificant inhibitory effect in line with that of AZT and Saquinavir was only lethal to *Toxoplasma* at concentrations cytotoxic to the human host cells. Nelfinavir and Ritonavir, however, blocked parasite growth at concentrations that were sub-lethal to human host cells. The main mechanism of pathogenicity in *Candida* infection is by hyphal growth. (82, 158) The major treatment of *Candida* infections has been the use of azole and polyene drugs (147) which inhibit hyphal growth and therefore prevent candidoses development. The effect of HIV protease inhibitors on *Candida* hyphal growth is unclear.

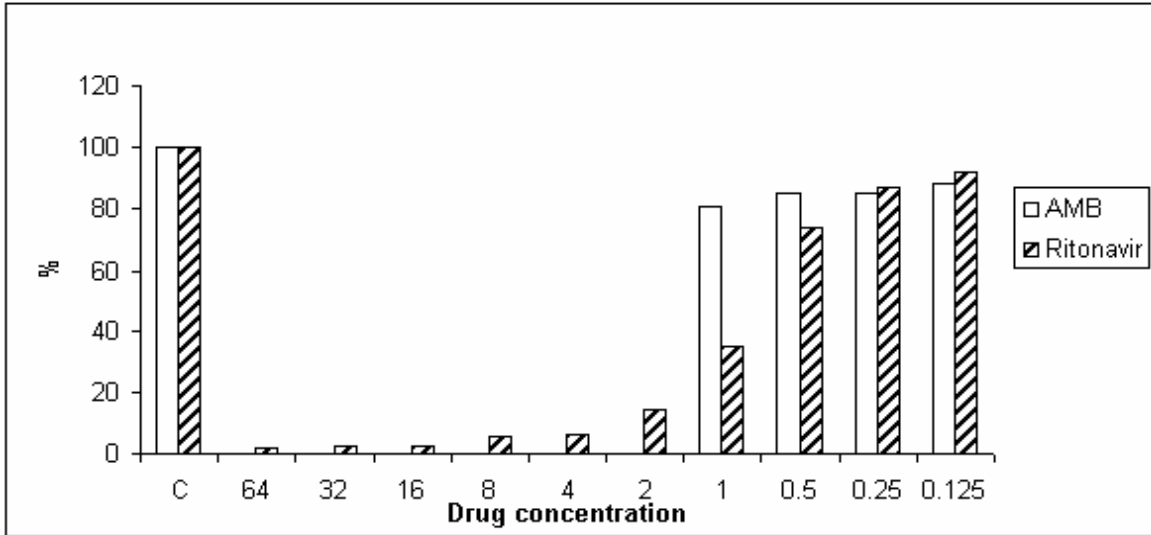
In studies using scanning and transmission electron microscopy, some antifungal drugs caused inhibition of growth and morphological changes in *C. albicans* and *A. fumigatus*. (46, 159, 160) These structural alterations were attributed to depletion of ergosterol. (161) Hyphal-deficient mutants are known to be avirulent in infections.(142, 154) *C. albicans* extracellular proteolytic activity due to secreted aspartic proteases has been purposed as putative virulence factor during the tissue invasion process by hyphal cells. Felk *et al.* (2002) (4) showed that strains that produced hyphal cells but lacked hyphal-associated proteases were less invasive. Thus the hyphal morphology *per se* seems not make the fungus invasive.(142) Several studies (62, 67, 162) showed inhibitory effects of Indinavir and Ritonavir on the yeast growth of *Candida albicans*. They established that a particularly virulent form of *C. albicans* associated with HIV infection produces a secretory aspartyl protease. This protease is inhibited by the HIV PIs. Using an experimental mouse model of vaginal candidoses, De Bernardis *et al.* 1999 (163) demonstrated that the PIs had a therapeutic efficacy comparable to that of fluconazole.

The present study was succeeded in showing the inhibitory effect of ritonavir on a single hyphae tip growth of *C. albicans*. Our findings suggest that ritonavir was effective in the inhibition of hyphal growth therefore explaining in part the reduction of oral

candidoses prevalence. The mechanism of PI action in controlling virulence factors associated with hyphal formation and growth is not known and requires further investigation.

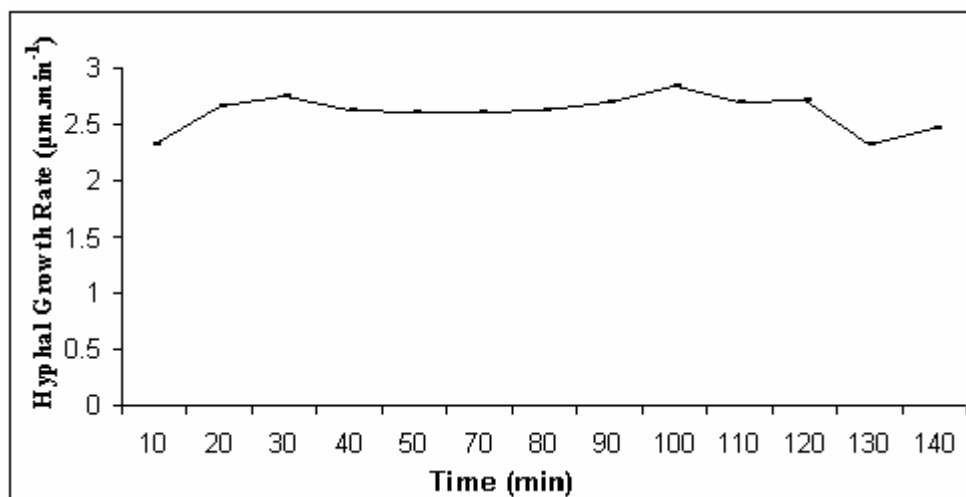
### **Acknowledgments**

This work was supported by Japan International Cooperation Agency (JICA).  
Dr Andrew Warrilow for proof-reading of this manuscript.

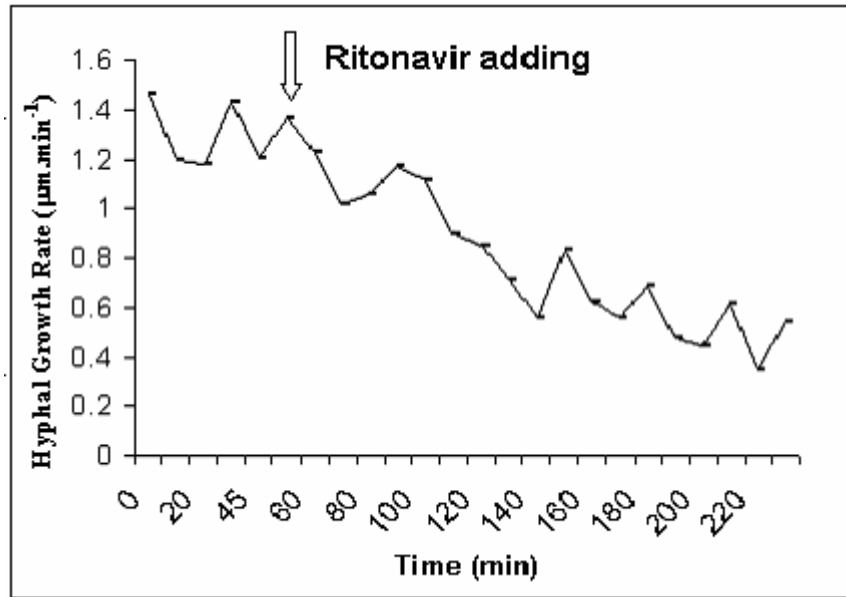


**Fig. 1** - Percentage of specific growth rate (cells.h<sup>-1</sup>) of *C. albicans* in the presence of amphotericin B and ritonavir at concentration ranging from 0.125 to 64 µg/ml.

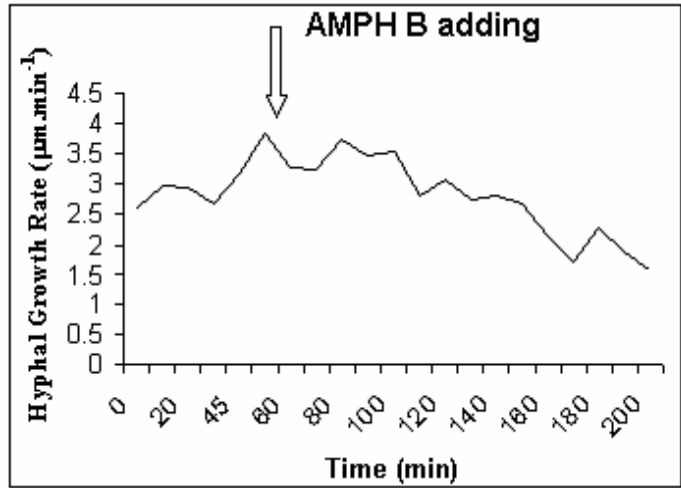




**Fig. 2** - Time course of the growth rate of individual hyphae of *C. albicans* control (no drug added).



**Fig. 3** - Time course of the growth rate of individual hyphae of *C. albicans*. Ritonavir at concentration of 58 µg/ml was added after 60 min of stable growth rate of hyphal tip.



**Fig. 4** - Time course of the growth rate of individual hyphae of *C. albicans*. AMB at concentration of 0.125 µg/ml was added as indicated by the arrow.

## References

1. Challacombe, S. J. (1994). Immunologic aspects of oral candidiasis. *Oral Surg Oral Med Oral Pathol* **78**, 202-210.
2. Melo, N. R., Taguchi, H., Jorge, J. *et al.* (2004). Oral Candida flora from Brazilian human immunodeficiency virus-infected patients in the highly active antiretroviral therapy era. *Mem Inst Oswaldo Cruz* **99**, 425-431.
3. Swinne, D., Watelle, M., Van der Flaes, M. *et al.* (2004). In vitro activities of voriconazole (UK-109, 496), fluconazole, itraconazole and amphotericin B against 132 non-albicans bloodstream yeast isolates (CANARI study). *Mycoses* **47**, 177-183.
4. Perea, S. (2000). [Azole resistance in *Candida albicans*]. *Rev Esp Quimioter* **13**, 314-317.
5. Kelly, S. L., Lamb, D. C., Kelly, D. E. *et al.* (1997). Resistance to fluconazole and cross-resistance to amphotericin B in *Candida albicans* from AIDS patients caused by defective sterol delta5,6-desaturation. *FEBS Lett* **400**, 80-82.
6. Karababa, M., Coste, A. T., Rognon, B. *et al.* (2004). Comparison of gene expression profiles of *Candida albicans* azole-resistant clinical isolates and laboratory strains exposed to drugs inducing multidrug transporters. *Antimicrob Agents Chemother* **48**, 3064-3079.
7. Perea, S., Fothergill, A. W., Sutton, D. A. *et al.* (2001). Comparison of in vitro activities of voriconazole and five established antifungal agents against different species of dermatophytes using a broth macrodilution method. *J Clin Microbiol* **39**, 385-388.
8. Moran, G. P., Sanglard, D., Donnelly, S. M. *et al.* (1998). Identification and expression of multidrug transporters responsible for fluconazole resistance in *Candida dubliniensis*. *Antimicrob Agents Chemother* **42**, 1819-1830.
9. Jackson, C. J., Lamb, D. C., Manning, N. J. *et al.* (2003). Mutations in *Saccharomyces cerevisiae* sterol C5-desaturase conferring resistance to the CYP51 inhibitor fluconazole. *Biochem Biophys Res Commun* **309**, 999-1004.

10. Borg-von Zepelin, M., Zäschke, K., Gross, U. *et al.* (2002). Effect of Micafungin (FK463) on *Candida albicans* adherence to epithelial cells. *Chemotherapy* **48**, 148-153.
11. Sandven, P. (1990). Laboratory identification and sensitivity testing of yeast isolates. *Acta Odontol Scand* **48**, 27-36.
12. Beighton, D., Ludford, R., Clark, D. T. *et al.* (1995). Use of CHROMagar *Candida* medium for isolation of yeasts from dental samples. *J Clin Microbiol* **33**, 3025-3027.
13. Standards, N. C. f. C. L. (1997). Reference Method for Broth Dilution Antifungal Susceptibility Testing of Yeast:. *Approved Standard M27-A*.
14. Groeneveld, P., Rolley, N., Kell, D. B. *et al.* (2002). Metabolic control analysis and engineering of the yeast sterol biosynthetic pathway. *Mol Biol Rep* **29**, 27-29.
15. Sanglard, D., Kuchler, K., Ischer, F. *et al.* (1995). Mechanisms of resistance to azole antifungal agents in *Candida albicans* isolates from AIDS patients involve specific multidrug transporters. *Antimicrob Agents Chemother* **39**, 2378-2386.
16. Joseph-Horne, T., Loeffler, R. S., Hollomon, D. W. *et al.* (1996). Amphotericin B resistant isolates of *Cryptococcus neoformans* without alteration in sterol biosynthesis. *J Med Vet Mycol* **34**, 223-225.
17. National Committee for Clinical Laboratory Standard (2002). Reference Method for Broth Dilution Antifungal Susceptibility Testing of Yeasts. *NCCLS document M27-2A*. Wayne, Pa.
18. Kelly, S. L., Lamb, D. C., Kelly, D. E. *et al.* (1996). Resistance to fluconazole and amphotericin in *Candida albicans* from AIDS patients. *Lancet* **348**, 1523-1524.
19. Walsh, T. J., Gonzalez, C., Lyman, C. A. *et al.* (1996). Invasive fungal infections in children: recent advances in diagnosis and treatment. *Adv Pediatr Infect Dis* **11**, 187-290.
20. Hope, W. W., Taberner, L., Denning, D. W. *et al.* (2004). Molecular mechanisms of primary resistance to flucytosine in *Candida albicans*. *Antimicrob Agents Chemother* **48**, 4377-4386.

21. Martin, E., Parras, P. & Lozano, M. C. (1992). In vitro susceptibility of 245 yeast isolates to amphotericin B, 5-fluorocytosine, ketoconazole, fluconazole and itraconazole. *Chemotherapy* **38**, 335-339.
22. Cassone, A., De Bernardis, F., Torosantucci, A. *et al.* (1999). In vitro and in vivo anticandidal activity of human immunodeficiency virus protease inhibitors. *J Infect Dis* **180**, 448-453.
23. Hood, S., Bonington, A., Evans, J. *et al.* (1998). Reduction in oropharyngeal candidiasis following introduction of protease inhibitors. *Aids* **12**, 447-448.
24. Migliorati, C. A., Birman, E. G. & Cury, A. E. (2004). Oropharyngeal candidiasis in HIV-infected patients under treatment with protease inhibitors. *Oral Surg Oral Med Oral Pathol Oral Radiol Endod* **98**, 301-310.
25. Blanco, M. T., Hurtado, C., Perez-Giraldo, C. *et al.* (2003). Effect of ritonavir and saquinavir on *Candida albicans* growth rate and in vitro activity of aspartyl proteinases. *Med Mycol* **41**, 167-170.
26. Pozio, E. (2004). [Highly Active AntiRetroviral Therapy and opportunistic protozoan infections]. *Parassitologia* **46**, 89-93.
27. Lamb, D. C., Kelly, D. E., White, T. C. *et al.* (2000). The R467K amino acid substitution in *Candida albicans* sterol 14 $\alpha$ -demethylase causes drug resistance through reduced affinity. *Antimicrob Agents Chemother* **44**, 63-67.
28. Venkateswarlu, K., Denning, D. W., Manning, N. J. *et al.* (1995). Resistance to fluconazole in *Candida albicans* from AIDS patients correlated with reduced intracellular accumulation of drug. *FEMS Microbiol Lett* **131**, 337-341.
29. Franz, R., Kelly, S. L., Lamb, D. C. *et al.* (1998). Multiple molecular mechanisms contribute to a stepwise development of fluconazole resistance in clinical *Candida albicans* strains. *Antimicrob Agents Chemother* **42**, 3065-3072.
30. Sullivan, D. J., Westerneng, T. J., Haynes, K. A. *et al.* (1995). *Candida dubliniensis* sp. nov.: phenotypic and molecular characterization of a novel species associated with oral candidiasis in HIV-infected individuals. *Microbiology* **141** ( Pt 7), 1507-1521.

31. Sano, A., Vilela, M. M., Takahashi, I. *et al.* (2000). Isolation of *Candida dubliniensis* from the oral cavity of an HIV-positive child in Brazil. *Nippon Ishinkin Gakkai Zasshi* **41**, 177-181.
32. Coleman, D. C., Sullivan, D. J., Bennett, D. E. *et al.* (1997). Candidiasis: the emergence of a novel species, *Candida dubliniensis*. *Aids* **11**, 557-567.
33. Pfaller, M. A., Jones, R. N., Doern, G. V. *et al.* (1999). International surveillance of blood stream infections due to *Candida* species in the European SENTRY Program: species distribution and antifungal susceptibility including the investigational triazole and echinocandin agents. SENTRY Participant Group (Europe). *Diagn Microbiol Infect Dis* **35**, 19-25.
34. Cuenca-Estrella, M., Rodero, L., Garcia-Effron, G. *et al.* (2002). Antifungal susceptibilities of *Candida* spp. isolated from blood in Spain and Argentina, 1996-1999. *J Antimicrob Chemother* **49**, 981-987.
35. Moran, G. P., Sullivan, D. J., Henman, M. C. *et al.* (1997). Antifungal drug susceptibilities of oral *Candida dubliniensis* isolates from human immunodeficiency virus (HIV)-infected and non-HIV-infected subjects and generation of stable fluconazole-resistant derivatives in vitro. *Antimicrob Agents Chemother* **41**, 617-623.
36. Tsuchiya T, T. M. (1980). Serological characterization. . *Methods Microbiol* **16**, 26-75.
37. Biswas SK, Y. K., Wang L, Nishimura K, Miyaji M (2001). Identification of *Candida dubliniensis* based on the specific amplification of mitochondrial cytochrome b gene. *Nippon Ishinkin Gakkai Zasshi* **42(2)**, 95-98.
38. National Committee for Clinical Laboratory Standards (NCCLS). National Committee for Clinical Laboratory Standards (1997). *Reference method for broth dilution antifungal susceptibility testing of yeasts; approved standard. NCCLS document M27-A. Wayne, Pa. .*
39. Sanglard D, K. K., Ischer F, Pagani JL, Monod M, Bille. (1995). Mechanisms of resistance to azole antifungal agents in *Candida albicans* isolates from AIDS patients involve specific multidrug transporters. *J. Antimicrob Agents Chemother* **39**, 2378-2386.

40. Nguyen MH, P. J., Jr., Morris AJ, Tanner DC, Nguyen ML, Snyderman DR et al. (1996). The changing face of candidemia: emergence of non-*Candida albicans* species and antifungal resistance. *Am J Med* **100**, 617-623. .
41. Schorling, S. R., Kortinga, H. C., Froschb, M. *et al.* (2000). The role of *Candida dubliniensis* in oral candidiasis in human immunodeficiency virus-infected individuals. *Crit Rev Microbiol* **26**, 59-68.
42. Sullivan, S., Coleman D. (1998). *Candida dubliniensis*: characteristics and identification. *J Clin Microbiol* **36** 329-334.
43. Soll, D. R. (1992). High-frequency switching in *Candida albicans*. *Clin Microbiol Rev* **5**, 183-203.
44. Milan, E. P., de Laet Sant' Ana, P., de Azevedo Melo, A. S. *et al.* (2001). Multicenter prospective surveillance of oral *Candida dubliniensis* among adult Brazilian human immunodeficiency virus-positive and AIDS patients. *Diagn Microbiol Infect Dis* **41**, 29-35.
45. Mariano Pde, L., Milan, E. P., da Matta, D. A. *et al.* (2003). *Candida dubliniensis* identification in Brazilian yeast stock collection. *Mem Inst Oswaldo Cruz* **98**, 533-538.
46. Pinjon, E., Moran, G. P., Jackson, C. J. *et al.* (2003). Molecular mechanisms of itraconazole resistance in *Candida dubliniensis*. *Antimicrob Agents Chemother* **47**, 2424-2437.
47. Buurman, E. T., Blodgett, A. E., Hull, K. G. *et al.* (2004). Pyridines and pyrimidines mediating activity against an efflux-negative strain of *Candida albicans* through putative inhibition of lanosterol demethylase. *Antimicrob Agents Chemother* **48**, 313-318.
48. Perea, S., Lopez-Ribot, J. L., Kirkpatrick, W. R. *et al.* (2001). Prevalence of molecular mechanisms of resistance to azole antifungal agents in *Candida albicans* strains displaying high-level fluconazole resistance isolated from human immunodeficiency virus-infected patients. *Antimicrob Agents Chemother* **45**, 2676-2684.
49. Vilela, M. M., Kamei, K., Sano, A. *et al.* (2002). Pathogenicity and virulence of *Candida dubliniensis*: comparison with *C. albicans*. *Med Mycol* **40**, 249-257.



50. **Odds, F. C.** (1988). *Candida* and Candidiasis, 2<sup>nd</sup> edn. London: Balliere Tindall.
51. Watts, H. J., Cheah, F. S., Hube, B. *et al.* (1998). Altered adherence in strains of *Candida albicans* harbouring null mutations in secreted aspartic proteinase genes. *FEMS Microbiol Lett* **159**, 129-135.
52. Kretschmar, M., Felk, A., Staib, P. *et al.* (2002). Individual acid aspartic proteinases (Saps) 1-6 of *Candida albicans* are not essential for invasion and colonization of the gastrointestinal tract in mice. *Microb Pathog* **32**, 61-70.
53. Felk, A., Kretschmar, M., Albrecht, A. *et al.* (2002). *Candida albicans* hyphal formation and the expression of the Efg1-regulated proteinases Sap4 to Sap6 are required for the invasion of parenchymal organs. *Infect Immun* **70**, 3689-3700.
54. Korting, H. C., Schaller, M., Eder, G. *et al.* (1999). Effects of the human immunodeficiency virus (HIV) proteinase inhibitors saquinavir and indinavir on in vitro activities of secreted aspartyl proteinases of *Candida albicans* isolates from HIV-infected patients. *Antimicrob Agents Chemother* **43**, 2038-2042.
55. Hoegl, L., Thoma-Greber, E., Rocken, M. *et al.* (1998). HIV protease inhibitors influence the prevalence of oral candidiasis in HIV-infected patients: a 2-year study. *Mycoses* **41**, 321-325.
56. Hoegl, L., Ollert, M. & Korting, H. C. (1996). The role of *Candida albicans* secreted aspartic proteinase in the development of candidoses. *J Mol Med* **74**, 135-142.
57. Wu, T., Wright, K., Hurst, S. F. *et al.* (2000). Enhanced extracellular production of aspartyl proteinase, a virulence factor, by *Candida albicans* isolates following growth in subinhibitory concentrations of fluconazole. *Antimicrob Agents Chemother* **44**, 1200-1208.
58. de Capriles, C. H., Mata-Essayag, S., Perez, C. *et al.* (2005). Detection of *Candida dubliniensis* in Venezuela. *Mycopathologia* **160**, 227-234.
59. Kretschmar, M., Hube, B., Bertsch, T. *et al.* (1999). Germ tubes and proteinase activity contribute to virulence of *Candida albicans* in murine peritonitis. *Infect Immun* **67**, 6637-6642.

60. Kelly, S. L., Lamb, D. C., Cannieux, M. *et al.* (2001). An old activity in the cytochrome P450 superfamily (CYP51) and a new story of drugs and resistance. *Biochem Soc Trans* **29**, 122-128.
61. Broughton, M. C., Bard, M. & Lees, N. D. (1991). Polyene resistance in ergosterol producing strains of *Candida albicans*. *Mycoses* **34**, 75-83.
62. **National Committee for Clinical Laboratory Standards (NCCLS)**. Reference method for broth dilution antifungal susceptibility testing of yeasts; approved standard. NCCLS document M27-A. National Committee for Clinical Laboratory Standards (1998).
63. Atzori, C., Angeli, E., Mainini, A. *et al.* (2000). In vitro activity of human immunodeficiency virus protease inhibitors against *Pneumocystis carinii*. *J Infect Dis* **181**, 1629-1634.
64. Cauda, R., Tacconelli, E., Tumbarello, M. *et al.* (1999). Role of protease inhibitors in preventing recurrent oral candidiasis in patients with HIV infection: a prospective case-control study. *J Acquir Immune Defic Syndr* **21**, 20-25.
65. De Bernardis, F., Tacconelli, E., Mondello, F. *et al.* (2004). Anti-retroviral therapy with protease inhibitors decreases virulence enzyme expression in vivo by *Candida albicans* without selection of avirulent fungus strains or decreasing their anti-mycotic susceptibility. *FEMS Immunol Med Microbiol* **41**, 27-34.
66. Derouin, F. & Santillana-Hayat, M. (2000). Anti-toxoplasma activities of antiretroviral drugs and interactions with pyrimethamine and sulfadiazine in vitro. *Antimicrob Agents Chemother* **44**, 2575-2577.
67. Lo, H. J., Kohler, J. R., DiDomenico, B. *et al.* (1997). Nonfilamentous *C. albicans* mutants are avirulent. *Cell* **90**, 939-949.
68. Odds, F. C. (1985). Morphogenesis in *Candida albicans*. *Crit Rev Microbiol* **12**, 45-93.
69. Hewitt, W. (1981). Influence of curvature of response lines in antibiotic agar diffusion assays. *J Biol Stand* **9**, 1-13.

70. Van den Bossche, H., Willemsens, G., Cools, W. *et al.* (1980). In vitro and in vivo effects of the antimycotic drug ketoconazole on sterol synthesis. *Antimicrob Agents Chemother* **17**, 922-928.
71. Anaissie, E. J., Paetznick, V. L., Ensign, L. G. *et al.* (1996). Microdilution antifungal susceptibility testing of *Candida albicans* and *Cryptococcus neoformans* with and without agitation: an eight-center collaborative study. *Antimicrob Agents Chemother* **40**, 2387-2391.
72. Zaoutis, T. E., Foraker, E., McGowan, K. L. *et al.* (2005). Antifungal susceptibility of *Candida* spp. isolated from pediatric patients: A survey of 4 children's hospitals. *Diagn Microbiol Infect Dis* **52**, 295-298.
73. Belanger, P., Nast, C. C., Fratti, R. *et al.* (1997). Voriconazole (UK-109,496) inhibits the growth and alters the morphology of fluconazole-susceptible and -resistant *Candida* species. *Antimicrob Agents Chemother* **41**, 1840-1842.
74. Ansheng, L., Taguchi, H., Miyaji, M. *et al.* (1999). Study on the hyphal responses of *Aspergillus fumigatus* to the antifungal agent by Bio-Cell Tracer. *Mycopathologia* **148**, 17-23.
75. Sanati, H., Belanger, P., Fratti, R. *et al.* (1997). A new triazole, voriconazole (UK-109,496), blocks sterol biosynthesis in *Candida albicans* and *Candida krusei*. *Antimicrob Agents Chemother* **41**, 2492-2496.
76. Gruber, A., Speth, C., Lukasser-Vogl, E. *et al.* (1999). Human immunodeficiency virus type 1 protease inhibitor attenuates *Candida albicans* virulence properties in vitro. *Immunopharmacology* **41**, 227-234.
77. de Bernardis, F., Mondello, F., Scaravelli, G. *et al.* (1999). High aspartyl proteinase production and vaginitis in human immunodeficiency virus-infected women. *J Clin Microbiol* **37**, 1376-1380.

***DISCUSSÃO GERAL***

O presente estudo analisou a influência do uso de Inibidores de Protease sobre a flora oral de crianças infectadas pelo HIV-1, comparando as espécies de leveduras identificadas antes e após terapia HAART. A incidência de infecções por fungos em pacientes infectados pelo HIV tem diminuído após a introdução dos inibidores de protease do HIV (10, 150). Estudos *in vitro* sugerem que inibidores de protease do HIV podem mostrar atividade inibitória para *Pneumocystis carinii* (150), *C. albicans* e *Toxoplasma gondii* (153, 164).

A mudança do perfil da flora oral nos dois momentos, nesta investigação, foi avaliada através do teste estatístico McNemar. Associação entre as variáveis (classificação clínica e imunológica, espécies identificadas, colonização por leveduras e manifestação oral) estudadas foi verificada através do teste exato de Fisher, nível de significância à 5%.

Isolados do grupo I (antes do uso de IP) foram identificados e as crianças em sua maioria (80%) estavam colonizadas por *C. albicans* e apenas 2 crianças não apresentaram isolados de *Candida* oral.

Na identificação à nível de espécies dos isolados de crianças infectadas pelo HIV-1 (n=52), do grupo I, 92.3% dos isolados eram *C. albicans*-A. Apenas 5 espécies Não- *albicans* foram identificadas representando uma baixa diversidade. Espécies menos comuns como *C. sake* e *C. dubliniensis* foram isoladas.

A variabilidade das amostras de levedura das crianças infectadas pelo HIV-1, do grupo II, diferiu significativamente daquela do grupo I (p=0.005). No grupo II 51.9% das crianças (n=27) foram colonizadas apenas por *C. albicans* e 28.8% das crianças (n=15) apresentaram colonização mista (isolados de *C. albicans* e Não - *albicans*). Portanto quando comparamos os grupos I e II, após o uso de IP houve uma importante redução no percentual de colonização por *C. albicans* de 80% para 51.9%, sugerindo um relevante efeito dos IP do HIV sobre a colonização oral. O presente estudo também demonstrou a inibição *in vitro* de hifas de *Candida* pelo ritonavir através do sistema *bio cell tracer*, portanto enfatizando o efeito de inibidor de protease em um dos fatores de virulência da *Candida*. Alguns dos agentes causadores de infecção fúngica sofrem transformação

morfológica de suas formas saprofíticas de levedura-like para micélio (forma parasítica) no tecido do hospedeiro. Este fenômeno de dimorfismo é um dos fatores mais importantes da patogenicidade de alguns fungos. Fagocitose de *C. albicans* por granulócitos ocorre durante os estágios iniciais da infecção e durante os estágios tardios a sua morte ocorre pela atividade de macrófagos. Demonstrou-se que o camundongo nu/nu é mais susceptível do que o nu/+, indicando que a fagocitose tem relevante papel durante o início da infecção e a imunidade mediada por célula durante a fase tardia. A defesa no camundongo nu/nu consiste principalmente de uma fase, fagocitose por granulócitos. Deste modo, é provável que a candidose em indivíduos infectados pelo HIV-1 pode ser causada por vários fatores: interação direta entre as proteínas do envelope e *C. albicans*; alterações nos mecanismos específicos e inespecíficos de defesa do hospedeiro e virulência das cepas.

A protease do HIV pertence a mesma classe da protease aspartato de *Candida*, que é um importante fator de virulência da mesma (165, 166). Alteração na produção de protease de *Candida* também foi associada á ligação das proteínas do envelope do HIV a superfície da célula fúngica (22). *Candida* protease tem importante participação nas etapas iniciais da invasão fúngica e na degradação da superfície epithelial (167, 168). Considerando que *C. albicans* é da mesma classe de protease do vírus HIV a terapia com IP parece estar afetando diretamente um dos fatores de virulência da *Candida* e conseqüentemente modificando o perfil de colonização oral. Este fato também se reflete na sensível redução da prevalência de manifestações orais associadas a AIDS, sobretudo na candidose oral. Os dados desta investigação são comparáveis àqueles observados em adultos infectados pelo HIV sob terapêutica com IP (46).

Destaca-se portanto os resultados estatisticamente significativos da correlação entre isolados identificados nos grupos GI e GII, particularmente com aumento da incidência de isolados Não - *albicans* ( $p=0.005$ ). No GI haviam 8 crianças que estavam colonizadas por espécies Não - *albicans* e no G2 haviam 20 crianças colonizadas com isolados Não - *albicans*. Entre as 8 crianças do GI quando avaliadas após a introdução do IP 3 delas deixaram de carrear isolados Não - *albicans* e 5 mantiveram a colonização. Quarenta e quatro crianças do G1 não estavam colonizados por isolados Não - *albicans* e 29 destas crianças mantiveram o perfil não colonizados por Não - *albicans*, e após o uso de

IP 15 crianças tornaram-se portadores de isolados Não - *albicans*. Portanto do percentual daqueles colonizados por ambas espécies (*albicans* e Não - *albicans*) houve um acentuado aumento ( $p=0.005$ ) de 9.6% para 28.8%.

A presença de isolados Não-*albicans* pode ser consequência da imunodeficiência e da terapêutica com drogas. O estado de imunossupressão pode facilitar a colonização por espécies menos virulentas, pois a capacidade de invasão das mesmas é facilitada (169).

Do total de 9 (17.3%) amostras de *C. tropicalis* 2 isolados (50%) estavam prevalentes na categoria imunológica 1 ( $p=0.04$ ). A literatura tem descrito que *C. tropicalis* é uma das espécies patogênicas mais virulentas portanto a presença de *C. tropicalis* em crianças infectadas pelo HIV-1 mesmo em fases iniciais da doença deveria ser monitorado.

De 52 crianças infectadas pelo HIV-1, sob terapia HAART, 230 isolados foram obtidos de swab oral e cultivado em meio cromogênico. Quatorze espécies de *Candida* foram identificadas no G2 e apenas 6 espécies no G1, mostrando um aumento significativo da incidência de espécies Não- *albicans* assim como alta diversidade. A segunda espécie mais frequente era a espécie *C. tropicalis* ( $n=9$ , 17.3%) seguida da *C. parapsilosis* ( $n=8$ , 15.4%). Uma observação interessante foi a ausência de colonização por espécie de *C. glabrata* que é frequentemente isolada em pacientes HIV positivo. Enquanto o isolamento de *C. dubliniensis*, espécie recentemente descrita e associada a infecção pelo HIV (170), foi de baixa prevalência 1.9% bastante baixa quando comparada com dados europeus. A mais alta diversidade de espécies de *Candida* no G2, com identificação de espécies raras, enfatiza uma possível influência do uso de IP sobre fatores de virulência particularmente na colonização por *Candida*. O uso de IP também parece estar associado ao aumento da incidência de espécies Não-*albicans* que apresentam baixa suscetibilidade a antifúngicos, assim como aquisição de novos isolados pelas crianças e comprometimento do estado imunológico. Portanto a mudança no perfil de colonização por *Candida* no grupos G1 a G2 enfatiza o provável efeito de HAART. A recorrência de candidose oral pode estar associada a espécies menos comuns que têm mostrado altos valores de MIC.

Considerando serotipo de *Candida albicans* foi observado resultado estatisticamente significativo (Teste McNemar  $p=0.005$ ) no qual o serotipo-A foi o mais frequente em ambos grupos. Antes do uso do IP haviam 48 crianças colonizadas com *Candida albicans*-A e após o uso de IP foi reduzido para 37 crianças, portanto uma redução de 92.3% para 71.2%. Interessantemente o serotipo-B foi encontrado apenas em 10 crianças do GII.

A menor virulência dos isolados de *C. albicans* sorotipo B tem sido sugerida (167, 171). O fato parece estar ligado à menor expressão de *Candida* protease e menor potencial de adesão e invasão do epitélio da mucosa. O uso prévio de agentes antifúngicos parece aumentar a capacidade de adesão celular dos fungos (169), conseqüentemente aumentando o potencial patogênico destes isolados.

A análise da manifestação oral foi realizada apenas no G2. Todas as 20 crianças estavam colonizadas por *C. albicans* e apenas 11 (55%) delas apresentavam cultura mista. Alta prevalência de cultura mista sugere uma sensível predisposição ao desenvolvimento de candidose oral. Estes dados estão de acordo com aqueles reportados por Moniaci et al. (172) onde os autores relacionaram a recorrência de candidose oral a mudança do perfil de colonização por outras espécies de *Candida* diferentes da colonização original. Embora não tenha sido comprovado algumas hipóteses têm sido sugeridas para a aquisição de outras espécies dentre elas re-infecção exógena, seleção de amostras resistentes a drogas antifúngicas e adicionalmente espécies diferentes podem representar várias expressões fenotípicas do mesmo genótipo. Estas variações fenotípicas podem ser devido a mudanças na resposta imune local, variações físico-químicas resultantes de terapia por drogas ou por variações envolvendo a ecologia oral (173). Entretanto quando compara-se a prevalência de candidose oral, da presente investigação aos dados descritos em estudos anteriores na terapia HAART destaca-se uma acentuada redução de valores em torno de 80-90% na prevalência de candidose oral em estudos prévios, contrastando aos 38.4% revelados em nosso estudo.

Vinte oito crianças (53.8%) não mostraram manifestação oral, entretanto destas 28 crianças 19 eram colonizadas por *Candida*. Apenas 4 crianças mostraram manifestação oral não associada a *Candida* e entre aquelas 3 eram portadoras de *Candida*.



Nas crianças sem nenhuma manifestação oral associada a *Candida*, 57.1% (n=16) carregavam *Candida albicans*-A. Das crianças com candidose oral 90% (n=18) eram portadores de isolados *Candida albicans*-A (p=0.033). A candidose oral ainda continua sendo a manifestação oral mais frequente. Parece que o monitoramento de portadores de isolados *Candida albicans*-A deveriam ser indicados para prevenção do desenvolvimento de candidose oral assim como provável progressão da doença.

Os resultados obtidos na correlação entre categoria imunológica e colonização por *Candida* sugerem uma mudança significativa na colonização após o uso de inibidores de protease particularmente para a categoria 3. Esta mudança se reflete no aumento da incidência de crianças (n=11, 21.1%) colonizadas por espécies Não - *albicans*. Basicamente a prevalência de colonização por *C. albicans* não variou entre os grupos GI e GII para as 3 categorias imunológicas. Mesmo crianças pertencentes as categorias 1 e 2 mostraram colonização por Não - *albicans*. Crianças pertencentes a categoria 3 apresentaram maior susceptibilidade a candidose oral.

Portanto deve-se considerar que além das modificações na composição da microbiota associadas ao uso dos antiretrovirais, também foram reportadas alterações nos fatores de virulência (174, 175). Isolados de *Candida* oriundos de pacientes infectados pelo HIV (que não estavam sob terapêutica com inibidores de protease) apresentavam maior atividade de protease do que isolados de indivíduos não infectados pelo HIV (70). Portanto, a terapêutica antiretroviral com inibidores de protease pode ter exercido efeito antifúngico sobre as espécies produtoras de protease e reduzido seu potencial de virulência, possibilitando a emergência de espécies não produtoras de protease como a *C.krusei*, *C. parapsilosis*, *C. guilliermondii* (168).

Apesar da alta sensibilidade dos isolados as drogas testadas no presente estudo, 4.4% (n=2) exibiram resistência ao fluconazole sendo que um dos isolados (*C. albicans*-B) demonstrou resistência cruzada a 9 agentes antifúngicos e foi sensível apenas ao voriconazol. O presente resultado sugere a necessidade de investigação mais extensa dos diferentes mecanismos de resistência que podem estar envolvidos. Segundo história médica da criança a mesma não recebeu tratamento com quaisquer com azoles previamente.

A maioria dos isolados *C. albicans*-A foi susceptível aos azoles testados exceto para o miconazole para o qual 9 isolados de *C. albicans*-A mostraram ser resistentes. Susceptibilidade antifúngica em isolados Não - *albicans* varia significativamente em contraste com *C. albicans*. Algumas espécies são resistentes primariamente como 75% dos isolados *C. krusei*, 35% de *C. glabrata*, 10-25% de *C. tropicalis* e *C. lusitaniae* (48). Neste estudo entre os isolados Não - *albicans* a maioria apresentou sensibilidade as drogas testadas. Entretanto um isolado de *C. tropicalis* foi resistente ao fluconazol (MIC > 64 µl/ml). Um isolado de *C. norvegensis* mostrou baixa sensibilidade aos azoles testados. Considerando que a recorrência de candidose oral pode estar associada a espécies menos comuns que tem apresentado altos valores de MIC portanto a presença de espécies raras em crianças infectadas pelo HIV-1 mesmo em fases iniciais da doença deve ser cuidadosamente monitorado. Muitos estudos sobre colonização e manifestações orais associadas ao HIV-1 têm sido realizados em adultos, apenas um pequeno número de estudos avaliam a patologia oral em crianças. Esta investigação potencialmente mostrou a influência do uso de terapêutica com Inibidores de Protease sobre a colonização oral por *Candida* em crianças infectadas pelo HIV-1. O presente estudo também revelou a emergência evidente de espécies Não - *albicans* que tem sido fortemente associada a quadros de recorrência de candidose oral e resistência de isolados de *Candida* oral. Também foi evidente a redução da prevalência de manifestações orais associadas a colonização por *Candida* após a introdução dos Inibidores de Protease.

***CONCLUSÃO GERAL***

- O presente estudo revelou mudança significativa na colonização oral por *Candida* em crianças infectadas pelo HIV-1 sob terapia HAART incluindo inibidores de protease.
- Alta diversidade de espécies de *Candida*, com emergência de espécies Não- *albicans* após o uso de inibidores de protease.
- Manifestação oral associada a colonização mista por espécies de *Candida*.
- Variabilidade na susceptibilidade aos agentes antifungicos testados.

***REFERÊNCIAS BIBLIOGRÁFICAS***

1. Challacombe SJ. Immunologic aspects of oral candidiasis. *Oral Surg Oral Med Oral Pathol.* 1994 Aug;78(2):202-10.
2. Pfaller MA. Epidemiology of candidiasis. *J Hosp Infect.* 1995 Jun;30 Suppl:329-38.
3. Fisher-Hoch SP, Hutwagner L. Opportunistic candidiasis: an epidemic of the 1980s. *Clin Infect Dis.* 1995 Oct;21(4):897-904.
4. Colombo AL. Epidemiology and treatment of hematogenous candidiasis: a Brazilian perspective. *Braz J Infect Dis.* 2000 Jun;4(3):113-8.
5. Samaranayake LP, Holmstrup P. Oral candidiasis and human immunodeficiency virus infection. *J Oral Pathol Med.* 1989 Dec;18(10):554-64.
6. Feigal DW, Katz MH, Greenspan D, Westenhouse J, Winkelstein W, Jr., Lang W, et al. The prevalence of oral lesions in HIV-infected homosexual and bisexual men: three San Francisco epidemiological cohorts. *Aids.* 1991 May;5(5):519-25.
7. Samaranayake LP. Oral mycoses in HIV infection. *Oral Surg Oral Med Oral Pathol.* 1992 Feb;73(2):171-80.
8. Coleman DC, Bennett DE, Sullivan DJ, Gallagher PJ, Henman MC, Shanley DB, et al. Oral *Candida* in HIV infection and AIDS: new perspectives/new approaches. *Crit Rev Microbiol.* 1993;19(2):61-82.
9. Cassone A, De Bernardis F, Torosantucci A. An outline of the role of anti-*Candida* antibodies within the context of passive immunization and protection from candidiasis. *Curr Mol Med.* 2005 Jun;5(4):377-82.
10. Cassone A, Tacconelli E, De Bernardis F, Tumbarello M, Torosantucci A, Chiani P, et al. Antiretroviral therapy with protease inhibitors has an early, immune reconstitution-independent beneficial effect on *Candida* virulence and oral candidiasis in human immunodeficiency virus-infected subjects. *J Infect Dis.* 2002 Jan 15;185(2):188-95.
11. Stevens DA. Fungal infections in AIDS patients. *Br J Clin Pract Suppl.* 1990 Sep;71:11-22.

12. Roilides E, Clerici M, DePalma L, Rubin M, Pizzo PA, Shearer GM. Helper T-cell responses in children infected with human immunodeficiency virus type 1. *J Pediatr*. 1991 May;118(5):724-30.
13. Silva MT, Centeville M, Tani SM, Toro AA, Rossi C, Vilela MM. [Serum immunoglobulins in children perinatally exposed to human immunodeficiency virus]. *J Pediatr (Rio J)*. 2001 May-Jun;77(3):209-18.
14. Mencacci A, Cenci E, G DS, Fe. DoC, C. M, Bacci A, et al. Immunoregulation in *Candida albicans* infection. *Mycoses*. 1999; 42:145.
15. Gonzalez CE, Venzon D, Lee S, Mueller BU, Pizzo PA, Walsh TJ. Risk factors for fungemia in children infected with human immunodeficiency virus: a case-control study. *Clin Infect Dis*. 1996 Sep;23(3):515-21.
16. Quinti I, Guerra E, Mezzaroma I, Scala E, Rainaldi L, Galluzzo CM, et al. Evaluation of a simplified test for the rapid detection of antibody to the human immunodeficiency virus (HIV-1). *Allergol Immunopathol (Madr)*. 1991 Jan-Feb;19(1):15-8.
17. Cantorna MT, Balish E. Role of CD4+ lymphocytes in resistance to mucosal candidiasis. *Infect Immun*. 1991;59:2447-55.
18. Imbert Bernard C, Valentim A, Reynes J, Malie M, Bastide J. Relationship between fluconazole sensitivity of *C. albicans* isolates from HIV-1 positive patients and serotype, adherence, and CD4+ lymphocyte count. *Eur J Clin Microbiol Infect Dis*. 1994;13:711-6.
19. Pietrella D, Monari C, Retini C, Pallazetti B, Bistoni F, Vechiarelli A. Human immunodeficiency virus type 1 envelope proteins gp120 impairs intracellular antifungal mechanisms in human monocytes *J Clin Microbiol*. 1998;177:347-54.
20. Wurznner R, Gruber A, Stoiber H, al. e. Human Immunodeficiency virus type 1 gp41 binds to *Candida albicans* via complement C3-like regions involving the human complement receptor type 3 CR3 analogue on *C. albicans*. *J Infect Dis* 1997;176:492-8.
21. Vartivarian SE. Virulence properties and nonimmune pathogenetic mechanisms of fungi. *Clin Infect Dis*. 1992 Jul;14(suppl 1) :S30-6.

22. Gruber A, Lukasser-Vogl E, Borg-von Zepelin M, Dierich MP, Wurzner R. Human immunodeficiency virus type 1 gp160 and gp41 binding to *Candida albicans* selectively enhances candidal virulence in vitro. *J Infect Dis.* 1998 Apr;177(4):1057-63.
23. Ibrahim AS, Mirbod F, Filler SG. Evidence implicate phospholipase as a virulence factor of *Candida albicans*. *Infect Immun.* 1995;63:1993-8.
24. Ollert MW, Wende C, Gorlich M. Increased expression of *C. albicans* secretory proteinase, a putative virulence factors isolates from human immunodeficiency virus positive patients. *J Clin Microbiol.* 1995;33:2543-9.
25. De Bernardis F, Chiani P, Ciccozzi M, Pellegrini G, Ceddia T, D'Offizzi G, et al. Elevated aspartic proteinase secretion and experimental pathogenicity of *Candida albicans* isolates from oral cavities of subjects infected with Human immunodeficiency Virus. *Infection and Immunity.* 1996;64(2)::466-71.
26. Wu T SL, Cao BY Wang J. . In-vitro proteinase product by oral *Candida albicans* isolates from individuals with and without HIV infection and its attenuation by antimycotic agents. *J Med Microbiol.* 1996; 44:311-6.
27. Walsh TJ, Pizzo PA. Experimental gastrointestinal and disseminated candidiasis in immunocompromised animals. *Eur j Epidemiol.* 1992; 8:477-83.
28. Barnett JA, Payne RW, Yarrow D. Descriptions of the species arranged alphabetically. In: *Yeasts: Characteristics and Identification.* 2nd edition JA Barnett, RW PAYNE, D Yarrow (Eds) Cambridge University Press: Cambridge 1990:109-277.
29. Pfaller MA. Nosocomial candidiasis: emerging species, reservoirs, and modes of transmission. *Clin Infect Dis.* 1996 May;22 Suppl 2:S89-94.
30. Powderly WG, Robinson K, Keath EJ. Molecular epidemiology of recurrent oral candidiasis in human immunodeficiency virus-positive patients: evidence for two patterns of recurrence. *J Infect Dis.* 1993;168:463-6
31. Sullivan DJ, Henman MC, Moran GP, O'Neill LC, Bennett DE, Shanley DB, et al. Molecular genetic approaches to identification, epidemiology and taxonomy of non-albicans *Candida* species. *J Med Microbiol.* 1996 Jun;44(6):399-408.



32. Nguyen MH, Peacock JE, Morris AJ. The changing face of candidemia; emergence of non candida albicans species and antifungal resistance. *Am J Med* 1996;100:617-23.
33. Sullivan DJ, Westerneng TJ, Haynes KA, Bennett DE, Coleman DC. *Candida dubliniensis* sp. nov.: phenotypic and molecular characterization of a novel species associated with oral candidiasis in HIV-infected individuals. *Microbiology*. 1995 Jul;141 (Pt 7):1507-21.
34. Sano A, M. M.S. Vilela, I. Takahashi, K. Fukushima, K. Takizawa, M. T. N. Silva, J. Uno, K. Nishimura, M. Miyaji. . Isolation of *Candida dubliniensis* from the oral cavity of an HIV-positive child from Brazil. *Japanese Journal of Medical Mycology*. 2000; 3 (41):57-9.
35. Sullivan D, Coleman D. *Candida dubliniensis*: an emerging opportunistic pathogen. *Curr Top Med Mycol*. 1997 Dec;8(1-2):15-25.
36. Vilela MM, Kamei K, Sano A, Tanaka R, Uno J, Takahashi I, et al. Pathogenicity and virulence of *Candida dubliniensis*: comparison with *C. albicans*. *Med Mycol*. 2002 Jun;40(3):249-57.
37. Odds FC. Ecology and epidemiology of *Candida* species. *Zentralbl Bakteriol Mikrobiol Hyg [A]*. 1984 Jul;257(2):207-12.
38. Torssander J, Morfeldt-Manson L, Biberfeld G, Karlsson A, Putkonen PO, Wasserman J. Oral *Candida albicans* in HIV infection. *Scand J Infect Dis*. 1987; 19(3):291-5.
39. Silva EB, Grotto HZ, Vilela MM. [Clinical aspects and complete blood counts in children exposed to HIV-1: comparison between infected patients and seroreverters]. *J Pediatr (Rio J)*. 2001 Nov-Dec;77(6):503-11.
40. Merhi VAL, Vilela MMS, Silva MTN, Lopez FA, Barros AAF. Evolution of nutritional status of infants infected with the human immunodeficiency virus. *São Paulo Medical Journal* 2000;118:148-53.

41. Toro AADC, Silva MTN, Zanardi V, Menezes J, Altemani Aa, Vilela MMS. Pulmonary disorders in brazilian children with HIV infection. *Journal Clinical Immunology*. 1999. ;90 (3)::438.
42. Ministério da Saúde. Boletim. 1999.
43. Ghannoum M, and L. B. Rice Antifungal agents: mode of action, mechanisms of resistance, and correlation of these mechanisms with bacterial resistance. *Clin Microbiol Rew* 1999;12:501-17.
44. Heelan JS, and SD, Coon K. Comparison of Rapid Testing Methods for Enzyme Production with tube method for presumptive identificationof *Candida albicans*. *J Clin Microbiol*. 1996;34(11):2847-49.
45. Nho S, Anderson MJ, Moore CB, Denning DW. Species differentiation by internally transcribed spacer PCR and HhaI digestion of fluconazole-resistant *Candida krusei*, *Candida inconspicua*, and *Candida norvegensis* strains. *J Clin Microbiol*. 1997 Apr;35(4):1036-9.
46. Melo NR, Taguchi H, Jorge J, Pedro RJ, Almeida OP, Fukushima K, et al. Oral Candida flora from Brazilian human immunodeficiency virus-infected patients in the highly active antiretroviral therapy era. *Mem Inst Oswaldo Cruz*. 2004 Jun;99(4):425-31.
47. Brandt ME, L. H. Harrison and et al. . *Candida dubliniensis* fungemia: first cases in North America. *Emerging Infectious Diseases*. 2000; 6(1):1-3.
48. Krcmery V, Barnes AJ. Non-*albicans* *Candida* spp. causing fungaemia: pathogenicity and antifungal resistance. *J Hosp Infect*. 2002 Apr;50(4):243-60.
49. Benjamin DK, Jr., Poole C, Steinbach WJ, Rowen JL, Walsh TJ. Neonatal candidemia and end-organ damage: a critical appraisal of the literature using meta-analytic techniques. *Pediatrics*. 2003 Sep;112(3 Pt 1):634-40.
50. Bodey GP, Mardani M, Hanna HA, Boktour M, Abbas J, Girgawy E, et al. The epidemiology of *Candida glabrata* and *Candida albicans* fungemia in immunocompromised patients with cancer. *Am J Med*. 2002 Apr 1;112(5):380-5.

51. Ashman RB, Papadimitriou JM. Production and function of cytokines in natural and acquired immunity to *Candida albicans* infection. *Microbiol Rev.* 1995 Dec;59(4):646-72.
52. Mencacci A, Spaccapelo R, Del Sero G, Enssle KH, Cassone A, Bistoni F, et al. CD4+ T-helper-cell responses in mice with low-level *Candida albicans* infection. *Infect Immun.* 1996 Dec;64(12):4907-14.
53. Hazen KC. New and emerging yeast pathogens. *Clin Microbiol Rev.* 1995 Oct;8(4):462-78.
54. Pfaller MA, Jones RN, Messer SA, Edmond MB, Wenzel RP. National surveillance of nosocomial blood stream infection due to species of *Candida* other than *Candida albicans*: frequency of occurrence and antifungal susceptibility in the SCOPE Program. SCOPE Participant Group. Surveillance and Control of Pathogens of Epidemiologic. *Diagn Microbiol Infect Dis.* 1998 Feb;30(2):121-9.
55. Cartledge JD, Midgley J, Gazzard BG. Non-*albicans* oral candidiasis in HIV-positive patients. *J Antimicrob Chemother.* 1999 Mar;43(3):419-22.
56. Barchiesi F, Morbiducci V, Ancarani F, Scalise G. Emergence of oropharyngeal candidiasis caused by non-*albicans* species of *Candida* in HIV-infected patients. *Eur J Epidemiol.* 1993 Jul;9(4):455-6.
57. Nguyen MH PJ, Jr., Morris AJ, Tanner DC, Nguyen ML, Snyderman DR et al. The changing face of candidemia: emergence of non-*Candida albicans* species and antifungal resistance. *Am J Med* 1996;100:617-23. .
58. Sobel JD, Ohmit SE, Schuman P, Klein RS, Mayer K, Duerr A, et al. The evolution of *Candida* species and fluconazole susceptibility among oral and vaginal isolates recovered from human immunodeficiency virus (HIV)-seropositive and at-risk HIV-seronegative women. *J Infect Dis.* 2001 Jan 15;183(2):286-93.
59. Dronda F, Alonso-Sanz M, Laguna F, Chaves F, Martinez-Suarez JV, Rodriguez-Tudela JL, et al. Mixed oropharyngeal candidiasis due to *Candida albicans* and non-*albicans Candida* strains in HIV-infected patients. *Eur J Clin Microbiol Infect Dis.* 1996 Jun;15(6):446-52.

60. Hoegl L, Thoma-Greber E, Rocken M, Korting HC. Persistent oral candidiasis by non-albicans *Candida* strains including *Candida glabrata* in a human immunodeficiency virus-infected patient observed over a period of 6 years. *Mycoses*. 1998 Sep-Oct;41(7-8):335-8.
61. Korting HC, Schaller M, Eder G, Hamm G, Bohmer U, Hube B. Effects of the human immunodeficiency virus (HIV) proteinase inhibitors saquinavir and indinavir on in vitro activities of secreted aspartyl proteinases of *Candida albicans* isolates from HIV-infected patients. *Antimicrob Agents Chemother*. 1999 Aug;43(8):2038-42.
62. Cassone A, De Bernardis F, Torosantucci A, Tacconelli E, Tumbarello M, Cauda R. In vitro and in vivo anticandidal activity of human immunodeficiency virus protease inhibitors. *J Infect Dis*. 1999 Aug;180(2):448-53.
63. Chakrabarti A, Ghosh A, Batra R, Kaushal A, Roy P, Singh H. Antifungal susceptibility pattern of non-albicans *Candida* species & distribution of species isolated from Candidaemia cases over a 5 year period. *Indian J Med Res*. 1996 Aug;104:171-6.
64. Collin B, Clancy CJ, Nguyen MH. Antifungal resistance in non- *albicans Candida* species. *Drug Resist Updat*. 1999 Feb;2(1):9-14.
65. Fidel PL, Jr., Vazquez JA, Sobel JD. *Candida glabrata*: review of epidemiology, pathogenesis, and clinical disease with comparison to *C. albicans*. *Clin Microbiol Rev*. 1999 Jan;12(1):80-96.
66. Colombo AL, Perfect J, DiNubile M, Bartizal K, Motyl M, Hicks P, et al. Global distribution and outcomes for *Candida* species causing invasive candidiasis: results from an international randomized double-blind study of caspofungin versus amphotericin B for the treatment of invasive candidiasis. *Eur J Clin Microbiol Infect Dis*. 2003 Aug;22(8):470-4.
67. Migliorati CA, Birman EG, Cury AE. Oropharyngeal candidiasis in HIV-infected patients under treatment with protease inhibitors. *Oral Surg Oral Med Oral Pathol Oral Radiol Endod*. 2004 Sep;98(3):301-10.

68. Tacconelli E, Bertagnolio S, Posteraro B, Tumbarello M, Boccia S, Fadda G, et al. Azole susceptibility patterns and genetic relationship among oral *Candida* strains isolated in the era of highly active antiretroviral therapy. *J Acquir Immune Defic Syndr*. 2002 Sep 1;31(1):38-44.
69. Markowitz M, Saag M, Powderly WG, Hurley AM, Hsu A, Valdes JM, et al. A preliminary study of ritonavir, an inhibitor of HIV-1 protease, to treat HIV-1 infection. *N Engl J Med*. 1995 Dec 7;333(23):1534-9.
70. De Bernardis F, Boccanera M, Rainaldi L, Guerra CE, Quinti I, Cassone A. The secretion of aspartyl proteinase, a virulence enzyme, by isolates of *Candida albicans* from the oral cavity of HIV-infected subjects. *Eur J Epidemiol*. 1992 May;8(3):362-7.
71. Abad-Zapatero C, Goldman R, Muchmore SW, Hutchins C, Stewart K, Navaza J, et al. Structure of a secreted aspartic protease from *C. albicans* complexed with a potent inhibitor: implications for the design of antifungal agents. *Protein Sci*. 1996 Apr;5(4):640-52.
72. Bein M, Schaller M, Korting HC. The secreted aspartic proteinases as a new target in the therapy of candidiasis. *Curr Drug Targets*. 2002 Oct;3(5):351-7.
73. Centers for Disease Control and Prevention (CDC). Revised classification system for HIV infection and expanded surveillance case definition for AIDS among adolescents and adults. *MMWR*. 1993;41:1-19.
74. Beighton D, Ludford R, Clark DT, Brailsford SR, Pankhurst CL, Tinsley GF, et al. Use of CHROMagar Candida medium for isolation of yeasts from dental samples. *J Clin Microbiol*. 1995 Nov;33(11):3025-7.
75. Sandven P. Laboratory identification and sensitivity testing of yeast isolates. *Acta Odontol Scand*. 1990 Feb;48(1):27-36.
76. Pindborg JJ, Williams DM. [An update of the classification and of the diagnostic criteria of oral lesions in HIV infection. The European Economic Community (EEC) and the Collaborative Center of the World Health Organization for the Oral Manifestations of HIV Infection]. *Minerva Stomatol*. 1993 May;42(5):223-7.

77. Axell T, Samaranayake LP, Reichart PA, Olsen I. A proposal for reclassification of oral candidiasis. *Oral Surg Oral Med Oral Pathol Oral Radiol Endod.* 1997 Aug;84(2):111-2.
78. Ramos-Gomez FJ, Petru A, Hilton JF, Canchola AJ, Wara D, Greenspan JS. Oral manifestations and dental status in paediatric HIV infection. *Int J Paediatr Dent.* 2000 Mar;10(1):3-11.
79. National Committee for Clinical Laboratory Standard. Reference Method for Broth Dilution Antifungal Susceptibility Testing of Yeasts. NCCLS document M27-2A Wayne, Pa. 2002.
80. Colombo AL, Nucci M, Salomao R, Branchini ML, Richtmann R, Derossi A, et al. High rate of non-*albicans* candidemia in Brazilian tertiary care hospitals. *Diagn Microbiol Infect Dis.* 1999 Aug;34(4):281-6.
81. Redding SW, Kirkpatrick WR, Dib O, Fothergill AW, Rinaldi MG, Patterson TF. The epidemiology of non-*albicans Candida* in oropharyngeal candidiasis in HIV patients. *Spec Care Dentist.* 2000 Sep-Oct;20(5):178-81.
82. Zaoutis TE, Foraker E, McGowan KL, Mortensen J, Campos J, Walsh TJ, et al. Antifungal susceptibility of *Candida* spp. isolated from pediatric patients: A survey of 4 children's hospitals. *Diagn Microbiol Infect Dis.* 2005 Aug;52(4):295-8.
83. Pfaller MA, Diekema DJ, Jones RN, Messer SA, Hollis RJ. Trends in antifungal susceptibility of *Candida* spp. isolated from pediatric and adult patients with bloodstream infections: SENTRY Antimicrobial Surveillance Program, 1997 to 2000. *J Clin Microbiol.* 2002 Mar;40(3):852-6.
84. Sugizaki MF, Rhoden CR, Bombonatti DM, Montelli AC, Martinson ME, Lopes CAM. Prevalence and *in vitro* antifungal susceptibility of *Candida* spp isolated from clinical specimens in Sao Paulo, Brazil. *Rev Iberoam Micol.* 1998;15:16-8.
85. Zaugg C, Borg-Von Zepelin M, Reichard U, Sanglard D, Monod M. Secreted aspartic proteinase family of *Candida tropicalis*. *Infect Immun.* 2001 Jan;69(1):405-12.

86. Barchiesi F, Spreghini E, Maracci M, Fothergill AW, Baldassarri I, Rinaldi MG, et al. In vitro activities of voriconazole in combination with three other antifungal agents against *Candida glabrata*. *Antimicrob Agents Chemother*. 2004 Sep;48(9):3317-22.
87. Mariano Pde L, Milan EP, da Matta DA, Colombo AL. *Candida dubliniensis* identification in Brazilian yeast stock collection. *Mem Inst Oswaldo Cruz*. 2003 Jun;98(4):533-8.
88. Zaoutis TE, Greves HM, Lautenbach E, Bilker WB, Coffin SE. Risk factors for disseminated candidiasis in children with candidemia. *Pediatr Infect Dis J*. 2004 Jul;23(7):635-41.
89. Mullen CA, Abd El-Baki H, Samir H, Tarrand JJ, Rolston KV. Non-*albicans* *Candida* is the most common cause of candidemia in pediatric cancer patients. *Support Care Cancer*. 2003 May;11(5):321-5.
90. Brian Smith P, Steinbach WJ, Benjamin DK, Jr. Invasive *Candida* infections in the neonate. *Drug Resist Updat*. 2005 Jun;8(3):147-62.
91. Schoofs AG, Odds FC, Colebunders R, Ieven M, Goossens H. Cross-sectional study of oral *Candida* carriage in a human immunodeficiency virus (HIV)-seropositive population: predisposing factors, epidemiology and antifungal susceptibility. *Mycoses*. 1998 May-Jun;41(5-6):203-11.
92. Ceballos-Salobrena A, Gaitan-Cepeda LA, Ceballos-Garcia L, Lezama-Del Valle D. Oral lesions in HIV/AIDS patients undergoing highly active antiretroviral treatment including protease inhibitors: a new face of oral AIDS? *AIDS Patient Care STDS*. 2000 Dec;14(12):627-35.
93. Frezzini C, Leao JC, Porter S. Current trends of HIV disease of the mouth. *J Oral Pathol Med*. 2005 Oct;34(9):513-31.
94. Chiou CC, Groll AH, Gonzalez CE, Callender D, Venzon D, Pizzo PA, et al. Esophageal candidiasis in pediatric acquired immunodeficiency syndrome: clinical manifestations and risk factors. *Pediatr Infect Dis J*. 2000 Aug;19(8):729-34.

95. Muller FM, Groll AH, Walsh TJ. Current approaches to diagnosis and treatment of fungal infections in children infected with human immuno deficiency virus. *Eur J Pediatr*. 1999 Mar;158(3):187-99.
96. Ruchel R, de Bernardis F, Ray TL, Sullivan PA, Cole GT. *Candida* acid proteinases. *J Med Vet Mycol*. 1992;30 Suppl 1:123-32.
97. Ruchel R, Uhlemann K, Boning B. Secretion of acid proteinases by different species of the genus *Candida*. *Zentralbl Bakteriol Mikrobiol Hyg [A]*. 1983;255:537-48.
98. Khongkuntian P, Grote M, Isaratanan W, Piyaworawong S, Reichart PA. Oral manifestations in 45 HIV-positive children from Northern Thailand. *J Oral Pathol Med*. 2001 Oct;30(9):549-52.
99. Margiotta V, Campisi G, Mancuso S, Accurso V, Abbadessa V. HIV infection: oral lesions, CD4+ cell count and viral load in an Italian study population. *J Oral Pathol Med*. 1999 Apr;28(4):173-7.
100. Margiotta V, Campisi G, Mancuso S. Plasma HIV-1 RNA and route of transmission in oral candidiasis and oral hairy leukoplakia. *Oral Dis*. 2000 May;6(3):194-5.
101. Campisi G, Pizzo G, Mancuso S, Margiotta V. Gender differences in human immunodeficiency virus-related oral lesions: an Italian study. *Oral Surg Oral Med Oral Pathol Oral Radiol Endod*. 2001 May;91(5):546-51.
102. Rex JH, Walsh TJ, Sobel JD, Filler SG, Pappas PG, Dismukes WE, et al. Practice guidelines for the treatment of candidiasis. Infectious Diseases Society of America. *Clin Infect Dis*. 2000 Apr;30(4):662-78.
103. Barry AL, Pfaller MA, Brown SD, Espinel-Ingroff A, Ghannoum MA, Knapp C, et al. Quality control limits for broth microdilution susceptibility tests of ten antifungal agents. *J Clin Microbiol*. 2000 Sep;38(9):3457-9.
104. Muller FM, Weig M, Peter J, Walsh TJ. Azole cross-resistance to ketoconazole, fluconazole, itraconazole and voriconazole in clinical *Candida albicans* isolates from HIV-infected children with oropharyngeal candidiasis. *J Antimicrob Chemother*. 2000 Aug;46(2):338-40.



105. Swinne D, Watelle M, Van der Flaes M, Nolard N. In vitro activities of voriconazole (UK-109, 496), fluconazole, itraconazole and amphotericin B against 132 non-*albicans* bloodstream yeast isolates (CANARI study). *Mycoses*. 2004 Jun;47(5-6):177-83.
106. Perea S. [Azole resistance in *Candida albicans*]. *Rev Esp Quimioter*. 2000 Sep;13(3):314-7.
107. Kelly SL, Lamb DC, Kelly DE, Manning NJ, Loeffler J, Hebart H, et al. Resistance to fluconazole and cross-resistance to amphotericin B in *Candida albicans* from AIDS patients caused by defective sterol delta5,6-desaturation. *FEBS Lett*. 1997 Jan 2;400(1):80-2.
108. Karababa M, Coste AT, Rognon B, Bille J, Sanglard D. Comparison of gene expression profiles of *Candida albicans* azole-resistant clinical isolates and laboratory strains exposed to drugs inducing multidrug transporters. *Antimicrob Agents Chemother*. 2004 Aug;48(8):3064-79.
109. Perea S, Fothergill AW, Sutton DA, Rinaldi MG. Comparison of in vitro activities of voriconazole and five established antifungal agents against different species of dermatophytes using a broth macrodilution method. *J Clin Microbiol*. 2001 Jan;39(1):385-8.
110. Moran GP, Sanglard D, Donnelly SM, Shanley DB, Sullivan DJ, Coleman DC. Identification and expression of multidrug transporters responsible for fluconazole resistance in *Candida dubliniensis*. *Antimicrob Agents Chemother*. 1998 Jul;42(7):1819-30.
111. Jackson CJ, Lamb DC, Manning NJ, Kelly DE, Kelly SL. Mutations in *Saccharomyces cerevisiae* sterol C5-desaturase conferring resistance to the CYP51 inhibitor fluconazole. *Biochem Biophys Res Commun*. 2003 Oct 3;309(4):999-1004.
112. Groeneveld P, Rolley N, Kell DB, Kelly SL, Kelly DE. Metabolic control analysis and engineering of the yeast sterol biosynthetic pathway. *Mol Biol Rep*. 2002;29(1-2):27-9.

113. Sanglard D, Kuchler K, Ischer F, Pagani JL, Monod M, Bille J. Mechanisms of resistance to azole antifungal agents in *Candida albicans* isolates from AIDS patients involve specific multidrug transporters. *Antimicrob Agents Chemother.* 1995 Nov;39(11):2378-86.
114. Joseph-Horne T, Loeffler RS, Hollomon DW, Kelly SL. Amphotericin B resistant isolates of *Cryptococcus neoformans* without alteration in sterol biosynthesis. *J Med Vet Mycol.* 1996 Jun-Jul;34(3):223-5.
115. Kelly SL, Lamb DC, Kelly DE, Loeffler J, Einsele H. Resistance to fluconazole and amphotericin in *Candida albicans* from AIDS patients. *Lancet.* 1996 Nov 30;348(9040):1523-4.
116. Hope WW, Taberner L, Denning DW, Anderson MJ. Molecular mechanisms of primary resistance to flucytosine in *Candida albicans*. *Antimicrob Agents Chemother.* 2004 Nov;48(11):4377-86.
117. Martin E, Parras P, Lozano MC. In vitro susceptibility of 245 yeast isolates to amphotericin B, 5-fluorocytosine, ketoconazole, fluconazole and itraconazole. *Chemotherapy.* 1992;38(5):335-9.
118. Hood S, Bonington A, Evans J, Denning D. Reduction in oropharyngeal candidiasis following introduction of protease inhibitors. *Aids.* 1998 Mar 5;12(4):447-8.
119. Blanco MT, Hurtado C, Perez-Giraldo C, Moran FJ, Gonzalez-Velasco C, Gomez-Garcia AC. Effect of ritonavir and saquinavir on *Candida albicans* growth rate and in vitro activity of aspartyl proteinases. *Med Mycol.* 2003 Apr;41(2):167-70.
120. Pozio E. [Highly Active AntiRetroviral Therapy and opportunistic protozoan infections]. *Parassitologia.* 2004 Jun;46(1-2):89-93.
121. Lamb DC, Kelly DE, White TC, Kelly SL. The R467K amino acid substitution in *Candida albicans* sterol 14alpha-demethylase causes drug resistance through reduced affinity. *Antimicrob Agents Chemother.* 2000 Jan;44(1):63-7.

122. Venkateswarlu K, Denning DW, Manning NJ, Kelly SL. Resistance to fluconazole in *Candida albicans* from AIDS patients correlated with reduced intracellular accumulation of drug. FEMS Microbiol Lett. 1995 Sep 15;131(3):337-41.
123. Franz R, Kelly SL, Lamb DC, Kelly DE, Ruhnke M, Morschhauser J. Multiple molecular mechanisms contribute to a stepwise development of fluconazole resistance in clinical *Candida albicans* strains. Antimicrob Agents Chemother. 1998 Dec;42(12):3065-72.
124. Coleman DC, Sullivan DJ, Bennett DE, Moran GP, Barry HJ, Shanley DB. Candidiasis: the emergence of a novel species, *Candida dubliniensis*. Aids. 1997 Apr;11(5):557-67.
125. Pfaller MA, Jones RN, Doern GV, Fluit AC, Verhoef J, Sader HS, et al. International surveillance of blood stream infections due to *Candida* species in the European SENTRY Program: species distribution and antifungal susceptibility including the investigational triazole and echinocandin agents. SENTRY Participant Group (Europe). Diagn Microbiol Infect Dis. 1999 Sep;35(1):19-25.
126. Cuenca-Estrella M, Rodero L, Garcia-Effron G, Rodriguez-Tudela JL. Antifungal susceptibilities of *Candida* spp. isolated from blood in Spain and Argentina, 1996-1999. J Antimicrob Chemother. 2002 Jun;49(6):981-7.
127. Moran GP, Sullivan DJ, Henman MC, McCreary CE, Harrington BJ, Shanley DB, et al. Antifungal drug susceptibilities of oral *Candida dubliniensis* isolates from human immunodeficiency virus (HIV)-infected and non-HIV-infected subjects and generation of stable fluconazole-resistant derivatives in vitro. Antimicrob Agents Chemother. 1997 Mar;41(3):617-23.
128. Tsuchiya T TM. Serological characterization. . Methods Microbiol 1980;16:26-75.
129. Biswas SK YK, Wang L, Nishimura K, Miyaji M. Identification of *Candida dubliniensis* based on the specific amplification of mitochondrial cytochrome b gene. Nippon Ishinkin Gakkai Zasshi 2001;42(2):95-8.

130. National Committee for Clinical Laboratory Standards (NCCLS). National Committee for Clinical Laboratory Standards. Reference method for broth dilution antifungal susceptibility testing of yeasts; approved standard. NCCLS document M27-A. Wayne, Pa. ; 1997.
131. Sanglard D KK, Ischer F, Pagani JL, Monod M, Bille. Mechanisms of resistance to azole antifungal agents in *Candida albicans* isolates from AIDS patients involve specific multidrug transporters. *J Antimicrob Agents Chemother.* 1995;39:2378-86.
132. Schorling SR, Kortinga HC, Froschb M, Muhlschlegel FA. The role of *Candida dubliniensis* in oral candidiasis in human immunodeficiency virus-infected individuals. *Crit Rev Microbiol.* 2000;26(1):59-68.
133. Sullivan S, Coleman D. *Candida dubliniensis*: characteristics and identification. *J Clin Microbiol* 1998;36:329-34.
134. Soll DR. High-frequency switching in *Candida albicans*. *Clin Microbiol Rev.* 1992;5:183-203.
135. Milan EP, de Laet Sant' Ana P, de Azevedo Melo AS, Sullivan DJ, Coleman DC, Lewi D, et al. Multicenter prospective surveillance of oral *Candida dubliniensis* among adult Brazilian human immunodeficiency virus-positive and AIDS patients. *Diagn Microbiol Infect Dis.* 2001 Sep-Oct;41(1-2):29-35.
136. Pinjon E, Moran GP, Jackson CJ, Kelly SL, Sanglard D, Coleman DC, et al. Molecular mechanisms of itraconazole resistance in *Candida dubliniensis*. *Antimicrob Agents Chemother.* 2003 Aug;47(8):2424-37.
137. Buurman ET, Blodgett AE, Hull KG, Carcanague D. Pyridines and pyrimidines mediating activity against an efflux-negative strain of *Candida albicans* through putative inhibition of lanosterol demethylase. *Antimicrob Agents Chemother.* 2004 Jan;48(1):313-8.
138. Perea S, Lopez-Ribot JL, Kirkpatrick WR, McAtee RK, Santillan RA, Martinez M, et al. Prevalence of molecular mechanisms of resistance to azole antifungal agents in *Candida albicans* strains displaying high-level fluconazole resistance isolated from human immunodeficiency virus-infected patients. *Antimicrob Agents Chemother.* 2001 Oct;45(10):2676-84.

139. **Odds FC.** *Candida* and Candidiasis, 2<sup>nd</sup> edn. London: Balliere Tindall. 1988.
140. Watts HJ, Cheah FS, Hube B, Sanglard D, Gow NA. Altered adherence in strains of *Candida albicans* harbouring null mutations in secreted aspartic proteinase genes. FEMS Microbiol Lett. 1998 Feb 1;159(1):129-35.
141. Kretschmar M, Felk A, Staib P, Schaller M, Hess D, Callapina M, et al. Individual acid aspartic proteinases (Saps) 1-6 of *Candida albicans* are not essential for invasion and colonization of the gastrointestinal tract in mice. Microb Pathog. 2002 Feb;32(2):61-70.
142. Felk A, Kretschmar M, Albrecht A, Schaller M, Beinhauer S, Nichterlein T, et al. *Candida albicans* hyphal formation and the expression of the Efg1-regulated proteinases Sap4 to Sap6 are required for the invasion of parenchymal organs. Infect Immun. 2002 Jul;70(7):3689-700.
143. Hoegl L, Thoma-Greber E, Rocken M, Korting HC. HIV protease inhibitors influence the prevalence of oral candidiasis in HIV-infected patients: a 2-year study. Mycoses. 1998 Sep-Oct;41(7-8):321-5.
144. Wu T, Wright K, Hurst SF, Morrison CJ. Enhanced extracellular production of aspartyl proteinase, a virulence factor, by *Candida albicans* isolates following growth in subinhibitory concentrations of fluconazole. Antimicrob Agents Chemother. 2000 May;44(5):1200-8.
145. de Capriles CH, Mata-Essayag S, Perez C, Colella MT, Rosello A, Olaizola C, et al. Detection of *Candida dubliniensis* in Venezuela. Mycopathologia. 2005 Oct;160(3):227-34.
146. Kretschmar M, Hube B, Bertsch T, Sanglard D, Merker R, Schroder M, et al. Germ tubes and proteinase activity contribute to virulence of *Candida albicans* in murine peritonitis. Infect Immun. 1999 Dec;67(12):6637-42.
147. Kelly SL, Lamb DC, Cannieux M, Greetham D, Jackson CJ, Marczylo T, et al. An old activity in the cytochrome P450 superfamily (CYP51) and a new story of drugs and resistance. Biochem Soc Trans. 2001 May;29(Pt 2):122-8.

148. Broughton MC, Bard M, Lees ND. Polyene resistance in ergosterol producing strains of *Candida albicans*. *Mycoses*. 1991 Jan-Feb;34(1-2):75-83.
149. **National Committee for Clinical Laboratory Standards (NCCLS)**. Reference method for broth dilution antifungal susceptibility testing of yeasts; approved standard. NCCLS document M27-A. National Committee for Clinical Laboratory Standards. 1998.
150. Atzori C, Angeli E, Mainini A, Agostoni F, Micheli V, Cargnel A. In vitro activity of human immunodeficiency virus protease inhibitors against *Pneumocystis carinii*. *J Infect Dis*. 2000 May;181(5):1629-34.
151. Cauda R, Tacconelli E, Tumbarello M, Morace G, De Bernardis F, Torosantucci A, et al. Role of protease inhibitors in preventing recurrent oral candidiasis in patients with HIV infection: a prospective case-control study. *J Acquir Immune Defic Syndr*. 1999 May 1;21(1):20-5.
152. De Bernardis F, Tacconelli E, Mondello F, Cataldo A, Arancia S, Cauda R, et al. Anti-retroviral therapy with protease inhibitors decreases virulence enzyme expression in vivo by *Candida albicans* without selection of avirulent fungus strains or decreasing their anti-mycotic susceptibility. *FEMS Immunol Med Microbiol*. 2004 May 1;41(1):27-34.
153. Derouin F, Santillana-Hayat M. Anti-toxoplasma activities of antiretroviral drugs and interactions with pyrimethamine and sulfadiazine in vitro. *Antimicrob Agents Chemother*. 2000 Sep;44(9):2575-7.
154. Lo HJ, Kohler JR, DiDomenico B, Loebenberg D, Cacciapuoti A, Fink GR. Nonfilamentous *C. albicans* mutants are avirulent. *Cell*. 1997 Sep 5;90(5):939-49.
155. Odds FC. Morphogenesis in *Candida albicans*. *Crit Rev Microbiol*. 1985;12(1):45-93.
156. Hewitt W. Influence of curvature of response lines in antibiotic agar diffusion assays. *J Biol Stand*. 1981 Jan;9(1):1-13.
157. Van den Bossche H, Willemsens G, Cools W, Cornelissen F, Lauwers WF, van Cutsem JM. In vitro and in vivo effects of the antimycotic drug ketoconazole on sterol synthesis. *Antimicrob Agents Chemother*. 1980 Jun;17(6):922-8.

158. Anaissie EJ, Paetznick VL, Ensign LG, Espinel-Ingroff A, Galgiani JN, Hitchcock CA, et al. Microdilution antifungal susceptibility testing of *Candida albicans* and *Cryptococcus neoformans* with and without agitation: an eight-center collaborative study. *Antimicrob Agents Chemother.* 1996 Oct;40(10):2387-91.
159. Belanger P, Nast CC, Fratti R, Sanati H, Ghannoum M. Voriconazole (UK-109,496) inhibits the growth and alters the morphology of fluconazole-susceptible and -resistant *Candida* species. *Antimicrob Agents Chemother.* 1997 Aug;41(8):1840-2.
160. Ansheng L, Taguchi H, Miyaji M, Nishimura K, Wu S. Study on the hyphal responses of *Aspergillus fumigatus* to the antifungal agent by Bio-Cell Tracer. *Mycopathologia.* 1999;148(1):17-23.
161. Sanati H, Belanger P, Fratti R, Ghannoum M. A new triazole, voriconazole (UK-109,496), blocks sterol biosynthesis in *Candida albicans* and *Candida krusei*. *Antimicrob Agents Chemother.* 1997 Nov;41(11):2492-6.
162. Gruber A, Speth C, Lukasser-Vogl E, Zangerle R, Borg-von Zepelin M, Dierich MP, et al. Human immunodeficiency virus type 1 protease inhibitor attenuates *Candida albicans* virulence properties in vitro. *Immunopharmacology.* 1999 Apr;41(3):227-34.
163. de Bernardis F, Mondello F, Scaravelli G, Pachi A, Girolamo A, Agatensi L, et al. High aspartyl proteinase production and vaginitis in human immunodeficiency virus-infected women. *J Clin Microbiol.* 1999 May;37(5):1376-80.
164. Derouin F. Anti-toxoplasmosis drugs. *Curr Opin Investig Drugs.* 2001 Oct;2(10):1368-74.
165. Korting HC. [Synergistic effects of terbinafine and itraconazole antimycotics]. *Hautarzt.* 1999 Jan;50(1):56-7.
166. Hoegl L, Korting HC, Klebe G. Inhibitors of aspartic proteases in human diseases: molecular modeling comes of age. *Pharmazie.* 1999 May;54(5):319-29.
167. Borg M, Ruchel R. Expression of extracellular acid proteinase by proteolytic *Candida* spp. during experimental infection of oral mucosa. *Infect Immun.* 1988 Mar;56(3):626-31.

168. Ray TL, Payne CD. Scanning electron microscopy of epidermal adherence and cavitation in murine candidiasis: a role for *Candida* acid proteinase. *Infect Immun*. 1988 Aug;56(8):1942-9.
169. Pereiro M, Jr., Losada A, Toribio J. Adherence of *Candida albicans* strains isolated from AIDS patients. Comparison with pathogenic yeasts isolated from patients without HIV infection. *Br J Dermatol*. 1997 Jul;137(1):76-80.
170. Coleman DC, Rinaldi MG, Haynes KA, Rex JH, Summerbell RC, Anaissie EJ, et al. Importance of *Candida* species other than *Candida albicans* as opportunistic pathogens. *Med Mycol*. 1998;36 Suppl 1:156-65.
171. Poulain D, Tronchin G, Vernes A, Popeye R, Biguet J. Antigenic variations of *Candida albicans* in vivo and in vitro--relationships between P antigens and serotypes. *Sabouraudia*. 1983 Jun;21(2):99-112.
172. Moniaci D, Greco D, Flecchia G, Raiteri R, Sinicco A. Epidemiology, clinical features and prognostic value of HIV-1 related oral lesions. *J Oral Pathol Med*. 1990 Nov;19(10):477-81.
173. Bruatto M, Vidotto V, Marinuzzi G, Raiteri R, Sinicco A. *Candida albicans* biotypes in human immunodeficiency virus type 1-infected patients with oral candidiasis before and after antifungal therapy. *J Clin Microbiol*. 1991 Apr;29(4):726-30.
174. De Bernardis F, Cassone A, Sturtevant J, Calderone R. Expression of *Candida albicans* SAP1 and SAP2 in experimental vaginitis. *Infect Immun*. 1995 May;63(5):1887-92.
175. Calderone RA, Fonzi WA. Virulence factors of *Candida albicans*. *Trends Microbiol*. 2001 Jul;9(7):327-35.



***ANEXOS***

## Caracterização da Flora Oral de Crianças fazendo uso de Inibidores de Protease

HC: _____	DATA: / / _____	NLAB: _____
Nome: _____ <b>CIPED</b>		
Natural.: _____ ( )	Data Nasc.: _/ _/ _ Idade( )	Sexo Mo Fo   Cor: Bo No Po Oo
CDC: A1o A2o A3o C4o Deso	CDC: B1o B2o B3o B4o	CDC: C1o C2o C3o C4o

## HISTORIA ODONTOLOGICA - PRIMEIRA CONSULTA

So No NSo	Algum problema na boca? Qual?
So No NSo	Já sofreu doença bucal? Qual? _____
So No NSo	Tipo de HBucal? Vezes/dia ____? Como ____? Aprendeu com: Famíliao Dentistao Outroso.
So No NSo	Vai regularmente ao dentista? Quantas vezes por ano? ____. Última visita foi a ____meses. Qual foi o motivo? _____
So No NSo	Queixas Oraís? Sente boca seca?

## Doenças Oportunistas:

DATA	PROTOZOÁRIOS	FUNGOS	VÍRUS	INFECÇÕES
	Criptosporidíasep	Histoplasmosep	Citomegalovírusp	TRS: Otites p
	P.carinii p	Criptococosep	Herpes simplesp	Sinusites p
	Isosporíasep	Candidose Oralp	Herpes zosterp	Amigdalites p
	Toxoplasmosep	Cand.Esofagianap	Leucoplasia pilosap	TRI: Pneumonias p
	outrosp		Varicela p	Outros Micobacteriasp

DATA	Outras Doenças

## MEDICAÇÃO UTILIZADA:

So No NSo	Faz uso de medicamentos
So No NSo	Toma medicação com supervisão
So No NSo	Toma medicação sem supervisão

MEDICAMENTOS:

DATA/2000	DOSE	DATA/1999	DOSE	DATA/1998	DOSE
MD 1:					
MD 2:					
MD 3:					
MD 4:					
MD 5:					
MD 6:					
MD 7:					
MD 8:					

**Caracterização da Flora Oral de Crianças fazendo uso de Inibidores de Protease**

IM	DATA	DATA	DATA	DATA	DATA
CD 3					
CD 4					
CD 8					
CV log					
Copias/ml					

Hemograma:

	DATA	DATA	DATA	DATA	DATA
Hb g/dl					
VCM					
LEU					
NT					
LINF					
PLQ					

Swab Oral	data ___/___/___	CHROMagar P1:	CHROMagar P2:
Contagens	Placa 1: _____	Placa 2: _____	Total: _____ Média: _____
Resultado: _____ UFC's/ml de saliva			

DATA	SAMPLE Numero LAB	CHROMagar

## AVALIAÇÃO DA MUCOSA BUCAL-

Afta menor	
Amígdala lingual hipertrófica	
Anquiloglossia	
Aumento inespecífico de glândula salivar	
Candidose eritematosa	
Candidose hipertrófica	
Candidose pseudomembranosa	
Despapilação lingual acentuada	
Despapilação lingual localizada	
Eritema gengival linear	
Estomatite úlcero-necrosante	
Gengivite úlcero-necrosante	
Glossite romboidal mediana	
Hemangioma	
Herpes simples recorrente	
Herpes zoster	
Hiperplasia fibrosa não associada a PT (fibroma)	
Infecção bacteriana <i>Actinomyces</i>	
Infecção bacteriana - Enterobacter	
Infecção bacteriana <i>Escherichia coli</i>	
Infecção bacteriana <i>Klebsiella pneumoniae</i>	
Infecção bacteriana <i>Mycobacterium avium</i>	
Infecções fúngicas (exceto <i>Candida</i> )	
Leucoedema	
Leucoplasia pilosa	
Linfoma não-Hodgkin	
Língua fissurada	
Língua geográfica	
Língua pilosa	
Língua saburrosa	
Líquen plano	
Molusco contagioso	
Neuropatia do trigêmeo	
Papiloma	
Parestesia	
Parotidite recorrente	
Periodontite Úlcero Necrosante	
Pigmentação exógena na mucosa bucal	
Pigmentação melânica (Addison/MD)	
Pigmentação melânica idiopática	
Pigmentação melânica racial	
Púrpura trombocitopênica	
Queilite angular	
Queratose reacional (traumática)	
Sarcoma de Kaposi	
Sinusite	
Toro mandibular	
Toro palatino	
Úlcera inespecífica	
Úlcera inespecífica do HIV	
Úlcera por CMV	
Ulceração traumática	
Xerostomia	
Outras (citar) _____	

**PESQUISA CLÍNICA**

**TÍTULO:** Caracterização da Flora Oral de Crianças fazendo uso de Inibidores de Protease

**PESQUISADORES:** Nadja Rodrigues de Melo e Maria Marluce dos Santos Vilela - Faculdade de Ciências Médicas (FCM) - UNICAMP

**LOCAL:** FCM e Centro de Investigação Pediátrica (CIPED) - UNICAMP

**1. INTRODUÇÃO:** As informações a seguir descreverão esta pesquisa e o papel que você terá como participante. Os pesquisadores responsáveis pelo estudo responderão a quaisquer perguntas que você possa ter sobre este termo e sobre o estudo. Por favor, leia-o cuidadosamente, e não hesite em perguntar qualquer coisa sobre as informações abaixo.

**2. PROPÓSITO:** Você está sendo convidado a participar de uma pesquisa clínica cujo objetivo é caracterizar a flora bucal de crianças HIV+ fazendo uso de inibidores de protease. determinar os fatores locais e sistêmicos em pacientes HIV+, associados a presença de diferentes espécies de *Candida* na saliva, assim como a quantidade, permitindo uma provável identificação dos pacientes mais predispostos ao desenvolvimento de candidose, facilitando a prevenção e tratamento desta freqüente infecção. Para você decidir se deseja ou não participar deste estudo de pesquisa, você deve entender o suficiente para fazer uma decisão consciente. Este processo é conhecido como consentimento informado.

**3. RETROSPECTIVA:** Candidose bucal e faríngea é a infecção oportunista mais comum em pacientes HIV+. Embora a candidose bucal não seja uma condição que *per si* defina o estado do paciente HIV+, ela reflete uma queda do sistema imune e o agravamento da doença. Candidose pode apresentar-se como uma lesão vermelha ou branca evidente e pode causar importante desconforto bucal. O portador assintomático do HIV pode ser cultura positiva para *Candida*, ainda que não apresente sinais clínicos e sintomas da infecção. Em indivíduos imunocomprometidos a candidose bucal pode conduzir a envolvimento extensivos e infecção sistêmica resultando até em morte. Devido a importância e prevalência da candidose, o diagnóstico e o controle da infecção são essenciais.

**4. DESCRIÇÃO DO ESTUDO:** Irão participar deste estudo, aproximadamente 100 pacientes, que estão sendo acompanhados pelo Grupo de Pesquisa em DST (GPD) da UNICAMP. Os pacientes que concordarem participar da pesquisa foram examinados clinicamente, entrevistados e foram coletadas amostras de saliva total. As coletas e exames foram realizados mensalmente, por um ano, durante as visitas de rotina ao GPD, não interferindo nos atendimentos médicos e não exigindo visitas adicionais. Cada coleta de saliva total durará cerca de 5 minutos e o método de coleta utilizado não é invasivo e nem acarreta qualquer dor, risco, custo ou dano imediato ou tardio ao paciente. Outros métodos de coleta possíveis de saliva são mais desconfortáveis e demorados. Não foram realizadas intervenções terapêuticas durante o período de estudo, exceto as realizadas pela equipe médica.

**5. DESCONFORTO, RISCOS E BENEFÍCIOS ESPERADOS:** O método de coleta salivar utilizado e o exame clínico aos quais os participantes da pesquisa foram submetidos são atraumáticos, não invasivos e não acarretam qualquer dor, risco, custo ou dano imediato ou potencial ao participante. Por outro lado oferecem elevada possibilidade de gerar conhecimento para compreensão, diagnóstico, prevenção ou alívio desta infecção fúngica, que afeta o bem-estar e a sobrevivência dos participantes desta pesquisa e de outros indivíduos. Uma identificação precoce de pacientes predispostos ao desenvolvimento de candidose, através da correlação entre quantificação, identificação das espécies, manifestação oral e marcadores laboratoriais associados ao HIV, poderá permitir o diagnóstico em fases iniciais, possibilitando o tratamento e até mesmo a prevenção desta frequente infecção, resultando em benefício na qualidade de vida e sobrevivência dos participantes da pesquisa e de outros pacientes com perfil imunológico similar.

**6. ALTERNATIVAS:** Outros métodos possíveis de coleta salivar não permitiriam ou dificultariam sobremaneira a determinação do fluxo salivar, como por exemplo o uso do lavado bucal ou swab (cotonete), ou seriam mais desconfortáveis e dispendiosos, como por exemplo a coleta com aparelhos especialmente desenvolvidos para coletas de parótida ou pipetas.

**7. EXCLUSÕES:** Não há critérios de exclusão no grupo desta pesquisa. Eventuais exclusões foram realizadas pelo GPD, por razões relacionadas com o próprio protocolo de pesquisa MK-639.

**8. COMPENSAÇÃO:** Não existem danos imediatos ou futuros previsíveis decorrentes da pesquisa, e portanto a mesma não inclui a possibilidade de indenização, sendo esta prevista apenas no protocolo MK-639 e por razões exclusivas do mesmo, como já foi referido no item anterior.

**9. CONFIDENCIALIDADE DOS REGISTROS:** Você tem direito a privacidade e toda informação que for obtida em relação a este estudo permanecerá confidencial nos âmbitos possíveis da lei, assegurando proteção de sua imagem, sigilo e respeitando valores culturais, sociais, morais, religiosos e éticos. A menos que a revelação seja exigida por ação legal ou regulatória, todos os esforços foram feitos para protegê-lo de ser identificado pessoalmente. Como condição de sua participação nesta pesquisa, você permite acesso aos dados obtidos durante o estudo, aos pesquisadores envolvidos neste estudo, aos membros da Comissão de Ética responsáveis pela análise do projeto e a agência financiadora. Os resultados deste projeto de pesquisa poderão ser apresentados em congressos ou em publicações, porém sua identidade não foi divulgada nessas apresentações.

**10. DIREITO em PARTICIPAR, RECUSAR ou SAIR:** Ao participar, você concorda em cooperar com os procedimentos que foram executados e que foram descritos acima, não abrindo mão de seus direitos legais ao assinar o termo de consentimento informado. Sua participação neste estudo é voluntária e você poderá recusar-se a participar ou poderá interromper sua participação a qualquer momento sem penalidades ou perda dos benefícios aos quais de outra forma tenha direito. O pesquisador tem o direito de desligá-lo do estudo a qualquer momento que julgar necessário. Se você sair voluntariamente ou for retirado pelo pesquisador, poderá ser solicitado que volte para eventuais coletas de amostras de saliva.

**11. CONTATOS:** Se ainda houver qualquer dúvida sobre o estudo você poderá receber mais esclarecimentos falando o Prof. Jacks Jorge por telefone (019) 430.5313, por e-mail [admfop@turing.unicamp.br](mailto:admfop@turing.unicamp.br) ou por carta: caixa postal 52, CEP 13414-018, Piracicaba - SP. Você poderá também discutir seus direitos como paciente de pesquisa com o presidente da Comissão de Ética da FOP/UNICAMP, o Prof. Antônio Bento de Moraes, pelo telefone (019) 430.5275.



## **CONSENTIMENTO DO PACIENTE**

Li a descrição do estudo de pesquisa clínica, que foi explicado dentro da minha compreensão e também conversei sobre este estudo com o pesquisador até minha completa satisfação. Compreendo que minha participação é voluntária e que posso sair a qualquer momento do estudo, sem prejudicar ou influenciar os resultados. Confirmo também que recebi cópia deste termo de consentimento.

Autorizo a liberação dos dados obtidos neste estudo aos pesquisadores, aos membros da comissão de ética e à comissão científica da FAPESP, assim como a publicação em revistas científicas especializadas e apresentação em congressos e jornadas científicas.

\*Não assine este termo se não tiver tido a oportunidade de fazer perguntas e tiver recebido respostas satisfatórias a todas elas.

---

Assinatura do Paciente - Data \_\_\_\_/ \_\_\_\_/ 1998

### **PESQUISADORES:**

---

Nadja Rodrigues de Melo

---

Maria Marluce dos Santos Vilela

Faculdade de Ciências Médicas (FCM) - UNICAMP



FACULDADE DE CIÊNCIAS MÉDICAS

**COMITÊ DE ÉTICA EM PESQUISA**

Caixa Postal 611  
13083-970 Campinas, S

☎ (0\_\_19) 3788-893

fax (0\_\_19) 3788-892

✉ [cep@head.fcm.unicamp.br](mailto:cep@head.fcm.unicamp.br)

CEP, 19/02/02  
(Grupo III)

**PARECER PROJETO: N°350/2001**

## **I-IDENTIFICAÇÃO:**

**PROJETO: “IDENTIFICAÇÃO DE LEVEDURAS DE CAVIDADE ORAL DE CRIANÇAS INFECTADAS PELO HIV-1, ANTES E DURANTE O USO DE INIBIDOR DE PROTEASE”**

**PESQUISADOR RESPONSÁVEL:** Maria Marluce dos Santos Vilela

**INSTITUIÇÃO:** Centro de Investigação Pediátrica (CIPED) FCM - UNICAMP

**APRESENTAÇÃO AO CEP:** 30/11/2001

## **II - OBJETIVOS**

Isolar e identificar a espécie da colonização fúngica da cavidade oral de crianças infectadas por transmissão vertical, antes e após o tratamento com inibidor de protease. Isolar e identificar leveduras da cavidade oral em crianças infectadas pelo HIV-1, antes e durante o tratamento HAART (highly active antiretroviral therapy). Avaliar a capacidade de killing dos granulócitos de crianças infectadas pelo HIV-1 para espécies patogênicas de *Candida* isoladas da cavidade oral. Relacionar a colonização com o uso de drogas antiretrovirais e com os marcadores de evolução da infecção pelo HIV-1, tais como: hemograma, carga viral e contagem de células T-CD4+. Avaliar o efeito in vitro dos agentes antifúngicos, em espécies de *Cândida* isoladas da cavidade oral.

## **III - SUMÁRIO**

Crianças infectadas pelo HIV-1, em tratamento antiretroviral no Setor de Imunologia-Alergia e Pneumologia do Depto. De Pediatria da FCM UNICAMP. Os pacientes serão divididos em dois grupos, a saber: Grupo I – material coletado antes do uso do inibidor de protease e grupo II – Material coletado durante o uso de IP. Os isolados clínicos a serem usados neste estudo serão obtidos através de swab oral das crianças. O método da coleta salivar utilizado e o exame clínico aos quais os participantes da pesquisa serão submetidos são atraumáticos, não invasivos e não acarretam qualquer dor, risco, custo ou dano imediato ou potencial ao paciente.

## **IV - COMENTÁRIOS DOS RELATORES**

A metodologia é adequada e bem elaborada, assim como as condições de realização do estudo. O projeto apresenta boa estrutura e tem justificativa adequada. O termo de consentimento é elucidativo e claro para os participantes.

## V - PARECER DO CEP

O Comitê de Ética em Pesquisa da Faculdade de Ciências Médicas da UNICAMP, após acatar os pareceres dos membros-relatores previamente designados para o presente caso e atendendo todos os dispositivos das Resoluções 196/96 e 251/97, bem como ter aprovado o Termo do Consentimento Livre e Esclarecido, assim como todos os anexos incluídos na Pesquisa, resolve aprovar sem restrições o Protocolo de Pesquisa supracitado.

## VI - INFORMAÇÕES COMPLEMENTARES

O sujeito da pesquisa tem a liberdade de recusar-se a participar ou de retirar seu consentimento em qualquer fase da pesquisa, sem penalização alguma e sem prejuízo ao seu cuidado (Res. CNS 196/96 – Item IV.1.f) e deve receber uma cópia do Termo de Consentimento Livre e Esclarecido, na íntegra, por ele assinado (Item IV.2.d).

Pesquisador deve desenvolver a pesquisa conforme delineada no protocolo aprovado e descontinuar o estudo somente após análise das razões da descontinuidade pelo CEP que o aprovou (Res. CNS Item III.1.z), exceto quando perceber risco ou dano não previsto ao sujeito participante ou quando constatar a superioridade do regime oferecido a um dos grupos de pesquisa (Item V.3.).

O CEP deve ser informado de todos os efeitos adversos ou fatos relevantes que alterem o curso normal do estudo (Res. CNS Item V.4.). É papel do pesquisador assegurar medidas imediatas adequadas frente a evento adverso grave ocorrido (mesmo que tenha sido em outro centro) e enviar notificação ao CEP e à Agência Nacional de Vigilância Sanitária – ANVISA – junto com seu posicionamento.

Eventuais modificações ou emendas ao protocolo devem ser apresentadas ao CEP de forma clara e sucinta, identificando a parte do protocolo a ser modificada e suas justificativas. Em caso de projeto do Grupo I ou II apresentados anteriormente à ANVISA, o pesquisador ou patrocinador deve enviá-las também à mesma junto com o parecer aprovatório do CEP, para serem juntadas ao protocolo inicial (Res. 251/97, Item III.2.e)

Relatórios parciais e final devem ser apresentados ao CEP, de acordo com os prazos estabelecidos na Resolução CNS-MS 196/96.

**Atenção: Projetos de Grupo I serão encaminhados à CONEP e só poderão ser iniciados após Parecer aprovatório desta.**

## VII - DATA DA REUNIÃO

Homologado na II Reunião Ordinária do CEP/FCM, em 19 de fevereiro de 2002.

  
**Prof. Dra. Carmen Silvia Bertuzzo**  
VICE-PRESIDENTE do COMITÊ DE ÉTICA EM PESQUISA  
FCM / UNICAMP