

Cristiane Mariote Amaral

***Influência das técnicas de polimerização das resinas
compostas na microinfiltração, microdureza,
formação de fendas e resistência à microtração***

Tese apresentada à Faculdade de Odontologia de Piracicaba, da Universidade Estadual de Campinas, para obtenção do título de Doutor em Clínica Odontológica, Área de Concentração Dentística.

Piracicaba
2003

Cristiane Mariote Amaral

***Influência das técnicas de polimerização das resinas
compostas na microinfiltração, microdureza,
formação de fendas e resistência à microtração***

Tese apresentada à Faculdade de Odontologia
de Piracicaba, da Universidade Estadual de
Campinas, para obtenção do título de Doutor
em Clínica Odontológica, Área de
Concentração Dentística.

Orientador: Prof. Dr. Luiz André Freire

Pimenta

Banca Examinadora:

Prof. Dr. Renato Herman Sundfeld

Prof. Dr. Walter Gomes Miranda Júnior

Profa. Dra. Giselle Maria Marchi Baron

Prof. Dr. Mário Alexandre Coelho Sinhoreti

Prof. Dr. Luiz André Freire Pimenta

Piracicaba

2003

Dedicatória

Dedico este trabalho aos meus pais ***Edione e Olavo***, que se empenharam para a minha formação pessoal e profissional. A vocês, que me ensinaram os valores mais importantes da vida e sempre foram meu estímulo e meu amparo. Agradeço a vocês e ao ***Eduardo*** pelo carinho e dedicação.

E ao ***Charles***, que sempre se fez presente junto a mim, fortalecendo-me e animando-me. Agradeço pelo carinho e pela atenção.

Dedico este trabalho a vocês que compartilham comigo a alegria de mais uma conquista e se realizam com a minha felicidade!

Agradecimentos

A ***Deus***, que tem sido minha força e meu refúgio.

Ao ***orientador*** e ***amigo***, Prof. Dr. Luiz André Freire Pimenta, que me conduziu com seriedade e com carinho nas atividades da Pós-Graduação. Agradeço por todos os ensinamentos técnicos e intelectuais, que sua capacidade e experiência possibilitaram. Agradeço também pelos conselhos e pela atenção que contribuíram para o meu crescimento pessoal.

À Faculdade de Odontologia de Piracicaba – UNICAMP, por ter sediado todos esses anos de estudo, tanto na graduação quanto na pós-graduação.

Ao Prof. Dr. Lourenço Correr Sobrinho, coordenador geral do curso de Pós-Graduação e à Profa. Dra. Brenda Paula Figueiredo A. Gomes, coordenadora do curso de Pós-Graduação em Clínica Odontológica, pela atenção, dedicação e competência.

À FAPESP - Fundação de Amparo à Pesquisa, pela concessão de bolsa de estudo (Processo 00/13681-6) e auxílio à pesquisa (Processo 01/05780-7) para a realização deste trabalho.

A todos os professores da Área de Dentística, que contribuíram para o meu aprendizado e desenvolvimento durante este período, e especialmente à Profa. Dra. Giselle Maria Marchi Baron pela atenção e amizade.

À Profa. Dra. Gláucia Maria Bovi Ambrosano pela realização das análises estatísticas, pela orientação e pela disponibilidade no atendimento.

Aos funcionários da Área de Dentística, Paula, Reinaldo e Pedro, pela amizade e colaboração durante este período.

A todos os colegas de Pós-Graduação da Dentística pela amizade, pela convivência e pelo aprendizado, tanto pessoal quanto profissional, que nossos relacionamentos possibilitaram. Especialmente à Alessandra e Larissa pelos trabalhos que realizamos juntas, que hoje nos possibilitam realizações e alegrias.

A todos os colegas da Pós-Graduação em Clínica Odontológica, com os quais tive o privilégio de trabalhar e trocar experiências.

Especialmente aos amigos Guto e Cláudia Cia, que estiveram sempre presentes com seu carinho e estímulo.

A todos que contribuíram para esta conquista: **MUITO OBRIGADA!**

Sumário

Resumo	1
Abstract	3
1. Introdução	5
2. Proposição	9
3. Capítulos	
3.1. Capítulo I	11
3.2. Capítulo II	33
3.3. Capítulo III	59
3.4. Capítulo IV	87
3.5. Capítulo V	109
4. Considerações Finais	133
5. Conclusões	137
6. Referências Bibliográficas	139
.....	149
Obras Consultadas	151
Anexos	

Resumo

Os objetivos deste trabalho, composto por cinco artigos científicos foram: 1) avaliar a microinfiltração e microdureza de restaurações de resina composta restauradas em incremento único ou incrementos vestibulo-linguais, polimerizadas com as técnicas convencional, *soft-start* e de intensidade progressiva; 2) avaliar o efeito das técnicas de polimerização *soft-start*, *pulse delay*, arco de plasma de Xenônio, alta intensidade (luz halógena) e convencional sobre a microinfiltração e formação de fendas de restaurações de resina composta, bem como avaliar a correlação entre esses dois testes e a influência da termociclagem na formação de fendas; 3) avaliar a microinfiltração e a microdureza de restaurações de resina composta usando três técnicas de polimerização (convencional, arco de plasma de Xenônio e *soft-start*) e duas diferentes resinas compostas (uma microhíbrida e uma condensável); 4) avaliar a microinfiltração de restaurações de resina composta microhíbrida e condensável polimerizadas com aparelhos à base de LEDs, com diferentes números de LEDs, em comparação com a polimerização convencional com luz halógena; 5) avaliar a influência das técnicas de polimerização *soft-start*, LED, arco de plasma de Xenônio e convencional na resistência à microtração de restaurações de resina composta microhíbrida e condensável. Os resultados encontrados mostraram que as técnicas de inserção e as técnicas de polimerização *soft-start*, intensidade progressiva, *pulse delay*, alta intensidade (luz halógena) e arco de plasma de Xenônio não afetaram a microinfiltração quando foi utilizada uma resina composta microhíbrida. Quando

foi utilizada uma resina composta condensável, as restaurações polimerizadas com a técnica convencional apresentaram microinfiltração similar às polimerizadas com a técnica *soft-start*, e menor microinfiltração que aquelas polimerizadas com arco de plasma de Xenônio. As técnicas de polimerização *soft-start*, *pulse delay*, alta intensidade (luz halógena) e arco de plasma de Xenônio também não afetaram a formação de fendas das restaurações, quando comparadas à polimerização convencional. Para a polimerização de intensidade progressiva ocorreu uma diminuição da microdureza das restaurações, enquanto as técnicas de polimerização *soft-start* e arco de plasma de Xenônio não afetaram a microdureza. Para todas as técnicas de polimerização avaliadas ocorreu uma diminuição da microdureza na base (terço gengival) das restaurações. As restaurações polimerizadas com aparelhos à base de LEDs apresentaram resultados de microinfiltração similares aos das polimerizadas com a técnica convencional, para duas resinas compostas. Entretanto, para a resina composta condensável, as restaurações polimerizadas com o aparelho composto por seis LEDs apresentaram microinfiltração significativamente maior que aquelas polimerizadas com o aparelho composto por dezenove LEDs. As técnicas de polimerização *soft-start*, LED e arco de plasma de Xenônio não afetaram a adesão das restaurações de resina composta, quando comparadas à polimerização convencional. Entretanto, as restaurações de resina composta condensável apresentaram significante menor resistência adesiva que as restaurações de resina composta microhíbrida, para todas as técnicas de polimerização.

Abstract

The aims of this study composed of five scientific articles were: 1) to evaluate the microleakage and microhardness of resin composite restorations filled in bulk placement or buccolingual increments, cured with the following polymerization techniques: conventional, soft-start, and progressive; 2) to evaluate the effect of soft-start, pulse delay, plasma arc curing, high intensity (halogen lamp), and conventional polymerization techniques on microleakage and gap formation of resin composite restorations, as well as to evaluate the correlation between these methodologies and the influence of thermocycling in gap formation; 3) to evaluate the microleakage and microhardness of resin composite restorations using three polymerization techniques (conventional, plasma arc curing and soft-start) and two different resin composites (one microhybrid and one packable); 4) to evaluate the microleakage of microhybrid and packable resin composite restorations polymerized with LED based devices, with different numbers of LEDs, compared with conventional halogen lamp; 5) to evaluate the influence of soft-start, LED unit, plasma arc curing, and conventional polymerization techniques on microtensile bond strength of microhybrid and packable resin composite restorations. The results showed that the insertion techniques and the polymerization techniques - soft-start, progressive, pulse delay, high intensity (halogen lamp) and plasma arc curing - did not affect the microleakage when a microhybrid resin composite was used. When a packable resin composite was used, restorations polymerized with conventional technique presented similar

microleakage to restorations polymerized with soft-start technique, and lower microleakage than restorations polymerized with plasma arc curing. When compared to conventional polymerization, the following polymerization techniques did not affect the gap formation of restorations: soft-start, pulse delay, high intensity (halogen lamp) and plasma arc. For progressive polymerization, microhardness of restorations decreased while the soft-start and the plasma arc polymerization techniques did not affect the microhardness. Microhardness in gingival third of restorations decreased for all polymerization techniques studied. Restorations polymerized with LED units presented similar microleakage to restorations polymerized with conventional technique for both resin composites – packable and microhybrid. However, for packable resin composite, the unit composed by six LEDs presented microleakage significantly more severe than the unit composed by nineteen LEDs. When compared with conventional polymerization (halogen lamp), soft-start, LED light curing, and plasma arc curing techniques did not affect the adhesion of resin composites restorations. However, packable resin composite restorations presented lower bond strength than microhybrid resin composite restorations, for all polymerization techniques.

1. Introdução

A demanda por restaurações estéticas tem causado um aumento do uso das resinas compostas em dentes posteriores (Crim & Chapman, 1994; Applequist & Meiers, 1996; Mehl *et al.*, 1997; Kurachi *et al.*, 2001; Yap *et al.*, 2002). Entretanto, as resinas compostas ainda apresentam algumas propriedades desfavoráveis, como por exemplo, o coeficiente de expansão térmica diferente da estrutura dental (Crim & Mattingly, 1981) e a contração de polimerização (Davidson & Feilzer, 1997; Mehl *et al.*, 1997; Yap *et al.*, 2001).

A contração de polimerização das resinas compostas pode causar grande tensão na interface dente-restauração e pode romper a adesão à parede cavitária (Davidson *et al.*, 1984; Feilzer *et al.*, 1987; Carvalho *et al.*, 1996), levando a falhas de união e, conseqüentemente, possibilitando a ocorrência de sensibilidade pós-operatória, microinfiltração e cáries secundárias (Eick & Welch, 1986; Davidson & Feilzer, 1997).

Na tentativa de minimizar as tensões da contração de polimerização das resinas compostas, têm sido estudadas técnicas de inserção em incremento único, incrementos horizontais, oblíquos e vestibulo-linguais (Eakle & Ito, 1990; Applequist & Meiers, 1996; Hilton *et al.*, 1997; Neiva *et al.*, 1998; Pimenta, 1999).

Muitas técnicas e novos sistemas de polimerização também têm sido desenvolvidos para tentar reduzir a tensão gerada pela contração, como as técnicas de polimerização *soft-start* (Uno & Asmussen, 1991; Mehl *et al.*, 1997; Alonso *et al.*,

2000; Friedl *et al.*, 2000; Martinez *et al.*, 2000; Yap *et al.*, 2001; Sahafi *et al.*, 2001; Yap *et al.*, 2002), progressiva (Burmam *et al.*, 2000; Walker & Burgess, 2000), *pulse delay* (Cardoso *et al.*, 2000; Walker & Burgess, 2000; Yap *et al.*, 2002) e a polimerização com intensidade de luz reduzida (Feilzer *et al.*, 1995; Unterbrink & Muessner, 1995; Goracci *et al.*, 1996).

A polimerização *soft-start* consiste na polimerização inicial da resina composta com baixa intensidade de luz, seguida pela polimerização final com alta intensidade (Yap *et al.*, 2002). Na polimerização progressiva, aparelhos desenvolvidos para essa técnica emitem luz com intensidade que aumenta gradativamente por um período, até atingir uma intensidade máxima, na qual permanece pelo tempo restante de polimerização (Walker & Burgess, 2000). Já a polimerização *pulse delay* envolve uma polimerização inicial de baixa intensidade, um período de espera em que pode ser realizado o acabamento da restauração, e uma polimerização final com alta intensidade (Yap & Seneviratne, 2001). Essas técnicas de polimerização citadas buscam uma lenta reação de polimerização, que aumenta o escoamento da resina composta, podendo ser útil para moderar o estresse de contração e melhorar a adaptação marginal (Uno & Asmussen, 1991; Feilzer *et al.*, 1995; Unterbrink & Muessner, 1995; Mehl *et al.*, 1997). Entretanto, outros estudos não encontraram melhora na adaptação marginal, quando a técnica de polimerização *soft-start* foi empregada (Friedl *et al.*, 2000; Sahafi *et al.*, 2001). Da mesma forma, não foi observada redução da contração de polimerização, quando as técnicas de polimerização *soft-start* e *pulse delay* foram utilizadas (Yap *et al.*, 2001; Yap *et al.*, 2002).

Também foi desenvolvido um novo sistema de polimerização: aparelhos com arco de plasma de Xenônio, cuja luz é emitida de um plasma composto por uma mistura gasosa de moléculas ionizadas e elétrons (Peutzfeldt *et al.*, 2000). Diferentemente das outras técnicas de polimerização, esses aparelhos emitem luz de alta intensidade (aproximadamente 1.500 mW/cm²). Assim, estes aparelhos podem reduzir em até 75% o tempo de polimerização das resinas compostas (Brackett *et al.*, 2000). Alguns estudos mostraram que esse tipo de polimerização produz igual ou menor contração de polimerização da resina composta que os aparelhos de polimerização convencional (Peutzfeldt *et al.*, 2000; Park *et al.*, 2002). Embora Brackett *et al.* (2000) tenham observado maior incidência de microinfiltração em restaurações polimerizadas com arco de plasma de Xenônio, Hasegawa *et al.* (2001) mostraram que essa polimerização não causa danos à interface restauradora.

Mais recentemente, sistemas de polimerização compostos por LEDs (light emitting diode) foram lançados. Esses aparelhos possuem vantagens como sua vida útil, que é de milhares de horas sem degradação do fluxo de luz (Mills *et al.*, 1999; Jandt *et al.*, 2000; Andrade *et al.*, 2001), e a não utilização de filtros para produzir luz azul (Mills *et al.*, 1999). Os LEDs azuis apresentam um pico de emissão de luz que coincide com o pico de absorção da canforoquinona (fotoiniciador mais comum das resinas compostas), tornando o processo de polimerização mais eficiente (Stahl *et al.*, 2000; Andrade *et al.*, 2001; Kurachi *et al.*, 2001). Entretanto, alguns estudos observaram que restaurações de resina composta polimerizadas com aparelhos à base de LEDs apresentam propriedades

físicas reduzidas quando comparadas às polimerizadas com luz halógena (Jandt *et al.*, 2000; Stahl *et al.*, 2000; Kurachi *et al.*, 2001).

Assim, devido à grande quantidade de técnicas e sistemas de polimerização disponíveis atualmente, tornam-se necessárias as avaliações para tentar encontrar a técnica que minimize os efeitos danosos da contração de polimerização, produzindo restaurações de resina composta com propriedades adequadas e com maior longevidade.

2. Proposição

Este trabalho, composto por cinco artigos científicos, apresentou como objetivo geral avaliar a influência de diferentes técnicas de polimerização na microinfiltração, microdureza, formação de fendas e resistência à microtração de restaurações de resina composta. Os objetivos específicos foram:

1. Avaliar a microinfiltração em restaurações de resina composta, realizadas com a técnica de incremento único ou de incrementos vestibulo-linguais, empregando a polimerização convencional, *soft-start* e de intensidade progressiva, bem como avaliar a microdureza do material restaurador para as técnicas empregadas;

2. Avaliar o efeito das técnicas de polimerização *soft-start*, *pulse delay*, arco de plasma de Xenônio, alta intensidade (luz halógena) e convencional sobre a microinfiltração e formação de fendas de restaurações de resina composta; a influência da termociclagem na formação de fendas bem como a correlação entre os testes de microinfiltração e formação de fendas também foram avaliadas;

3. Avaliar a microinfiltração e a microdureza de restaurações de resina composta usando três técnicas de polimerização (convencional, arco de plasma de Xenônio e *soft-start*) e duas diferentes resinas compostas (uma microhíbrida e uma condensável);

4. Avaliar a microinfiltração de restaurações de resina composta microhíbrida e condensável polimerizadas com diferentes aparelhos à base de

LEDs, com diferentes números de LEDs, em comparação com a polimerização convencional com luz halógena;

5. Avaliar a influência das técnicas de polimerização *soft-start*, LED, arco de plasma de Xenônio e convencional na resistência à microtração de restaurações de resina composta microhíbrida e condensável.

3.1. Capítulo I

***Efeito das técnicas de inserção e ativação da resina
composta sobre a microinfiltração e microdureza***

Pesquisa Odontológica Brasileira 2002; 16(3): 257-262

***Efeito das técnicas de inserção e ativação da resina
composta sobre a microinfiltração e microdureza***

***Effect of restorative and polymerization techniques of
composite resin on microleakage and microhardness***

Cristiane Mariote Amaral, DDS, MS¹; Ana Karina Barbieri Bedran de Castro, DDS, MS¹; Luiz André Freire Pimenta, DDS, MS, PhD²; Glaucia Maria Bovi Ambrosano, DDS, MS, PhD³.

1 - Pós-Graduanda em Clínica Odontológica, Área de Dentística, da Faculdade de Odontologia de Piracicaba – UNICAMP.

2 - Professor livre docente do Departamento de Odontologia Restauradora, Área de Dentística, da Faculdade de Odontologia de Piracicaba – UNICAMP.

3 - Professora Assistente Doutora do Departamento de Odontologia Social, Área de Bioestatística, da Faculdade de Odontologia de Piracicaba – UNICAMP.

Endereço para correspondência:

Prof. Dr. Luiz André Freire Pimenta

Faculdade de Odontologia de Piracicaba – Área de Dentística

Av. Limeira, 901 – Bairro Areião, Piracicaba – SP

CEP 13414-018

Fone: (0xx19) 3412.5340/ 3412.5337

Fax: (0xx19) 3412.5218

e-mail: lpimenta@fop.unicamp.br

Resumo: O objetivo deste trabalho foi avaliar a influência da técnica de ativação e de inserção da resina composta sobre a microinfiltração marginal e microdureza em restaurações classe II. Foram preparadas 180 cavidades que foram divididas em 6 grupos: G1 – incremento único + ativação convencional; G2 – incrementos vestibulo-linguais + ativação convencional; G3 – incremento único + ativação "soft-start"; G4 – incrementos vestibulo-linguais + ativação "soft-start"; G5 – incremento único + ativação progressiva; G6 - incrementos vestibulo-linguais + ativação progressiva. Todas as cavidades foram restauradas com o sistema Z100/Single Bond (3M). Após 1.000 ciclos térmicos (5 e 55°C), os espécimes foram imersos em solução aquosa de azul de metileno a 2%, por 4 horas e a microinfiltração foi avaliada. Metade dos espécimes foram incluídos em resina de poliestireno e a microdureza Knoop foi avaliada. Após o teste Kruskal-Wallis, não foi observada diferença significativa ($p>0,05$) entre todas as técnicas de ativação e de inserção quanto à microinfiltração. Quanto à microdureza, após os testes Análise de Variância (2 fatores) e Tukey, não houve diferença significativa entre as técnicas restauradoras empregadas ($p>0,05$), porém a ativação progressiva (G5 e G6) apresentou menor dureza Knoop ($p<0,05$): G1=144,11; G2=143,89; G3=141,14; G4=142,79; G5=132,15; G6=131,67. Concluiu-se que as técnicas de ativação e de inserção da resina composta não afetaram a microinfiltração, mas ocorreu uma diminuição na microdureza do material quando a ativação progressiva foi utilizada.

Unitermos: Resinas compostas; Infiltração dentária; Luz; Restauração dentária permanente; métodos.

Abstract: The aim of this study was to evaluate the influence of techniques of composite resin polymerization and insertion on microleakage and microhardness. One hundred and eighty class II cavities were prepared in bovine teeth and assigned to six groups: G1 – bulk filling + conventional polymerization; G2 – bucco-lingual increments + conventional polymerization; G3 – bulk filling + softstart polymerization; G4 – bucco-lingual increments + softstart polymerization; G5 – bulk filling + progressive polymerization; G6 – bucco-lingual increments + progressive polymerization. All cavities were restored with the Z100/Single Bond system (3M). After thermocycling, the samples were immersed in 2% methylene blue dye solution for 4 hours. Half of samples were embedded in polystyrene resin and Knoop microhardness was measured. The Kruskal-Wallis test did not reveal statistical differences ($p>0.05$) between the polymerization and insertion techniques as to microleakage. Regarding microhardness, the two-way ANOVA and the Tukey test did not reveal statistical differences between restorative techniques ($p>0,05$), but progressive polymerization (G5 and G6) was associated with smaller Knoop microhardness values ($p<0,05$): G1=144.11; G2=143.89; G3=141.14; G4=142.79; G5=132.15; G6=131.67. It was concluded that the polymerization and insertion techniques did not affect marginal microleakage, but a decrease in microhardness occurred when progressive polymerization was carried out.

Uniterms: Composite resins; Dental leakage; Light; Dental restoration permanent; methods.

Introdução

A demanda por restaurações estéticas e a melhoria das propriedades físicas das resinas compostas permitiram que esse material fosse utilizado para restaurar dentes posteriores ^{2, 5}. Entretanto, as resinas compostas ainda apresentam algumas propriedades desfavoráveis, tais como a contração de polimerização e o coeficiente de expansão térmica diferente da estrutura dental ^{6, 8, 16}.

Vários estudos reportaram que é desenvolvido estresse significativo durante a polimerização das resinas compostas, produzindo forças que podem separar a resina da estrutura dental ^{2, 4, 7}. Tem sido mostrado experimentalmente que uma lenta reação de polimerização das resinas compostas pode causar menos dano à interface da restauração, por aumentar o escoamento do material, diminuindo o estresse de contração de polimerização ^{10, 17, 23}. Isto pode ser obtido através da polimerização "soft-start" ou com baixa intensidade de luz, sem comprometer a polimerização do material ^{17, 23}.

O objetivo deste trabalho foi avaliar qualitativamente a microinfiltração marginal de restaurações classe II em resina composta, realizadas com a técnica de incremento único ou de incrementos vestibulo-linguais, empregando-se a ativação convencional, "soft-start" e de intensidade progressiva, bem como avaliar a dureza do material restaurador para as técnicas empregadas.

Material e Métodos

Análise da Microinfiltração Marginal

Foram selecionados 90 incisivos bovinos, que foram limpos e armazenados em solução de formol a 2%, pH 7,0. As coroas dos dentes foram seccionadas 5 mm acima da junção cimento-esmalte (JCE) com discos diamantados dupla face (KG Sorensen) e preparos cavitários, simulando classe II, tipo “slot” vertical, foram realizados nas faces mesial e distal de cada dente (Figura 1). Os preparos foram realizados 1 mm abaixo da JCE, com profundidade de 1,5 mm e largura de 3 mm, utilizando brocas nº 245 (JET Brand) de carboneto de tungstênio em turbina de alta rotação (KaVo), que foram trocadas a cada 5 cavidades, para que fosse possível manter a uniformidade dos preparos.

Em todos os grupos, foi aplicado o sistema adesivo Single Bond (3M), seguindo as recomendações do fabricante. A resina composta Z100 (3M), na cor A2, foi inserida de acordo com os seguintes grupos:

G1: incremento único com ativação convencional (Optilux 500 - Demetrom/Kerr) por 120 s, sendo 40 s por oclusal, 40 s por vestibular e 40 s por lingual.

G2: incrementos vestibulo-linguais (Figura 2)¹⁶ com ativação convencional (Optilux 500 - Demetrom/Kerr) por 40 s cada incremento.

G3: incremento único com ativação "soft-start" (Degulux Soft Start - Degussa Hüls) por 120 s, sendo 40 s por oclusal, 40 s por vestibular e 40 s por lingual.

G4: incrementos vestibulo-linguais¹⁶ com ativação "soft-start" (Degulux Soft Start - Degussa Hüls) por 40 s cada incremento.

G5: incremento único com ativação progressiva (KM 100-R - DMC Equipamentos) por 120 s, sendo 40 s por oclusal, 40 s por vestibular e 40 s por lingual.

G6: incrementos vestibulo-linguais¹⁶ com ativação progressiva (KM 100-R - DMC Equipamentos) por 40 s cada incremento.

A intensidade de luz dos aparelhos fotopolimerizadores foi medida e os seguintes valores foram observados: Optilux 500 (convencional) = 490 a 520 mW/cm²; Degulux Soft Start ("soft-start") = início 400 mW/cm² e após 20 segundos 710 a 720 mW/cm²; KM 100-R (progressiva) = aumento gradual da intensidade de 160 a 600 mW/cm² em 10 s, permanecendo em seguida na intensidade máxima.

Após o procedimento restaurador, foi realizado o polimento das restaurações com discos de óxido de alumínio Sof-Lex (3M) fino e extrafino. Em seguida, as restaurações foram submetidas à termociclagem em água destilada por 1.000 ciclos, em máquina de ciclagem térmica (Instrumental Instrumentos de Precisão), com banhos de 60 s às temperaturas de $5 \pm 2^\circ\text{C}$ e $55 \pm 2^\circ\text{C}$, com 5 s de tempo de transferência. O vedamento dos canais dos dentes bovinos foi realizado com cola epóxica (Araldite[®]) e também foram aplicadas duas camadas de esmalte cosmético (Risqué - Niasi S.A.), respeitando a distância limite de 1mm da margem cervical da restauração.

Todos os dentes ficaram imersos em solução aquosa de azul de metileno a 2% (pH 7,0) por 4 horas, depois foram lavados em água corrente e secos com papel absorvente. Finalmente, cada dente foi seccionado verticalmente, passando pelo centro da restauração, com discos diamantados dupla-face. A microinfiltração na margem gengival foi avaliada por 2 examinadores calibrados, em concordância, utilizando-se lupa estereoscópica (MEIJI – 2000), com aumento de 60 vezes, seguindo os critérios abaixo:

Grau 0: ausência de corante na interface dente-restauração.

Grau 1: penetração de corante até o primeiro terço da parede gengival.

Grau 2: penetração de corante até o intervalo entre o primeiro e o segundo terço da parede gengival.

Grau 3: com penetração de corante até o intervalo entre o segundo terço e o terceiro terço da parede gengival.

Grau 4: penetração de corante atingindo ou ultrapassando o ângulo áxio-cervical.

Os resultados da análise de microinfiltração foram submetidos ao teste de Kruskal-Wallis, ao nível de significância de 5% ($p < 0,05$).

Análise da Microdureza

Após a avaliação da microinfiltração, 15 metades de restaurações de cada grupo foram seccionadas com discos diamantados dupla face e foram agrupadas a cada três, dentro de tubos de PVC de $\frac{3}{4}$ de polegada, os quais foram preenchidos com resina de poliestireno (Cromex). Estes corpos-de-prova receberam

acabamento e polimento utilizando-se lixas de óxido de alumínio (Carborundum Abrasivos), com granulações 400, 600 e 1.000, montadas em politriz elétrica rotativa (Maxigrind–Solotest), refrigerada com água. O polimento final foi realizado com discos de feltro (Imptech International) associados a pastas de diamante (Imptech International) de 3 μm e 1 μm , com refrigeração a óleo mineral (Arotec Ind. Com. Ltda.).

O ensaio de microdureza foi realizado utilizando-se um microdurômetro (Future Tech – FM - 1E) e o penetrador tipo Knoop, com carga de 25 g e duração de aplicação de 20 s. As indentações foram localizadas a 100, 2.500 e 5.000 μm de distância da margem gengival, sendo 3 indentações para cada uma destas localizações.

As medidas foram transformadas em número de dureza Knoop e as médias de dureza para cada profundidade avaliada e para cada grupo experimental foram calculadas e submetidas à análise de variância (2 fatores), realizada em esquema de parcela subdividida e ao teste Tukey, ao nível de significância de 5% ($p < 0,05$).

Resultados

Na avaliação da microinfiltração, não foi observada diferença significativa entre as técnicas de inserção nem entre as técnicas de ativação utilizadas. A distribuição da frequência dos escores é apresentada na Tabela 1.

Quanto à microdureza, não foi observada diferença estatisticamente significativa entre as técnicas de inserção empregadas, mas a ativação progressiva

apresentou dureza significativamente menor da resina composta que as outras técnicas de ativação ($p < 0,05$). A dureza na porção mais profunda da restauração (a 100 μm da margem gengival) também foi significativamente menor que nas outras regiões, para todas as técnicas de ativação ($p < 0,05$) (Tabela 2).

Discussão

Várias técnicas têm sido estudadas para reduzir o estresse de contração de polimerização e, conseqüentemente, a infiltração marginal ¹⁴. Esses estudos incluem o uso de cunhas refletivas ^{15, 16}, técnicas de inserção ^{2, 13, 18, 21} e variações na intensidade de luz ^{10, 11, 17, 22, 23}.

Neste trabalho, não foi observada diferença estatisticamente significativa entre as técnicas de inserção empregadas em relação à microinfiltração. Esses resultados confirmam alguns estudos de microinfiltração, que compararam o emprego das técnicas de inserção de incremento único, incrementos horizontais, oblíquos e vestibulo-linguais, em que não foram observadas diferenças significantes entre as técnicas de inserção ^{9, 13, 21}.

Um recente método, designado a reduzir o estresse de contração e melhorar a adaptação marginal, consiste na conversão inicialmente reduzida da resina composta, controlando a capacidade de escoamento da restauração ^{8, 10, 22}. Um aumento no tempo de endurecimento de resinas compostas fotopolimerizáveis pode ser alcançado pela diminuição da intensidade de luz ¹⁰.

Vários autores observaram menor formação de fendas quando intensidades menores de luz foram utilizadas ^{10, 11, 17, 22, 23}. No entanto, outros

estudos não encontraram diferença estatística quanto à penetração de corantes, quando diferentes intensidades de luz foram utilizadas^{1, 3, 17}. Neste estudo também não foi observada diferença significativa na infiltração marginal quando diferentes técnicas de ativação foram utilizadas. No entanto, o aparelho *soft-start* usado neste trabalho apresenta intensidade de luz inicial de 400 mW/cm², intensidade bem maior que aquelas testadas em outros trabalhos (250 a 270 mW/cm²). A técnica de ativação progressiva também apresentou baixa intensidade de luz por poucos segundos, chegando rapidamente à intensidade de 600 mW/cm². Essas intensidades de luz provavelmente não permaneceram baixas por tempo suficiente para permitir uma lenta reação de polimerização.

Na avaliação da microdureza, não foi observada diferença estatisticamente significativa entre as técnicas de inserção avaliadas (incremento único e incrementos vestibulo-linguais), mas observou-se uma diminuição significativa da microdureza a 100 µm da margem gengival, para todas as técnicas de ativação ($p < 0,05$). Isto pode ter ocorrido devido à dificuldade de polimerização em maiores profundidades, pois a distância da fonte de luz e a espessura de resina composta a ser fotoativada pode influenciar a qualidade da polimerização^{12, 19, 20}.

A técnica de ativação progressiva apresentou redução estatisticamente significativa da dureza da resina composta quando comparada às outras técnicas de ativação ($p < 0,05$). Embora esta diminuição da dureza não tenha afetado a microinfiltração das restaurações, supõem-se que a longo prazo isso poderá trazer algum efeito negativo, relacionado à degradação do material²⁰.

Conclusões

Concluiu-se que as técnicas de ativação e de inserção da resina composta não afetaram a microinfiltração de restaurações classe II, havendo, entretanto, uma diminuição na microdureza do material próximo à margem gengival e quando a ativação progressiva foi utilizada. Assim, deve-se observar o custo-benefício de cada técnica de ativação e a técnica de inserção de escolha deve ser aquela que possa garantir uma boa adaptação e a polimerização adequada do material restaurador.

Referências Bibliográficas

1. Alonso RCB, Sinhoreti MAC, Consani S *et al.* Efeito do método de polimerização sobre a infiltração marginal em restaurações com compósitos odontológicos. *Pesqui Odontol Bras* 2000; 14: 55 [Resumo n. I353].
2. Applequist EA, Meiers JC. Effect of bulk insertion, prepolymerized resin composite balls, and beta-quartz inserts on microleakage of class V resin composite restorations. *Quintessence Int* 1996; 27(4): 253-8.
3. Burmann P, Cardoso PC, Silveira B *et al.* O efeito de diferentes técnicas de fotopolimerização sobre a microinfiltração. *Pesqui Odontol Bras* 2000; 14: 66 [Resumo n. A048].
4. Carvalho RM, Pereira JC, Yoshima M *et al.* A review of polymerization contraction: the influence of stress development versus stress relief. *Oper Dent* 1996; 21(1): 17-24.
5. Crim GA, Chapman KW. Reducing microleakage in class II restorations: an in vitro study. *Quintessence Int* 1994; 25(11): 781-5.
6. Crim GA, Mattingly SL. Evaluation of two methods for assessing marginal leakage. *J Prosthet Dent* 1981; 45(2): 160-3.
7. Davidson CL, De Gee AJ, Feilzer A. The competition between the composite-dentin bond strength and the polymerization contraction stress. *J Dent Res* 1984; 63(12): 1396-9.

8. Davidson CL, Feilzer AJ. Polymerization shrinkage and polymerization shrinkage stress in polymer-based restoratives. *J Dent* 1997; 25(6): 435-40.
9. Eakle WS, Ito RK. Effect of insertion technique on microleakage in mesio-occlusodistal composite resin restorations. *Quintessence Int* 1990; 21(5): 369-74.
10. Feilzer AJ, Dooren LH, De Gee AJ *et al.* Influence of light intensity on polymerization shrinkage and integrity of restoration-cavity interface. *Eur J Oral Sci* 1995; 103(5): 322-6.
11. Goracci G, Mori G, De' Martinis LC. Curing light intensity and marginal leakage of resin composite restorations. *Quintessence Int* 1996; 27(5): 355-62.
12. Hansen EK, Asmussen E. Visible-light curing units: correlation between depth of cure and distance between exit window and resin surface. *Acta Odontol Scand* 1997; 55(3): 162-6.
13. Hilton TJ, Schwartz RS, Ferracane JL. Microleakage of four class II resin composite insertion techniques at intraoral temperature. *Quintessence Int* 1997; 28(2): 135-44.
14. Kays BT, Sneed WD, Nuckles DB. Microhardness of class II composite resin restorations with different matrices and light positions. *J Prosthet Dent* 1991; 65(4): 487-90.

15. Lutz F, Krejci I, Luescher B *et al.* Improved proximal margin adaptation of class II composite resin restorations by use of light-reflecting wedges. *Quintessence Int* 1986; 17(10): 659-64.
16. Lutz F, Krejci I, Oldenburg TR. Elimination of polymerization stresses at the margins of posterior composite resin restorations: a new restorative technique. *Quintessence Int* 1986; 17(12): 777-84.
17. Mehl A, Hickel R, Kunzelmann KH. Physical properties and gap formation of light-cured composites with and without 'softstart-polymerization'. *J Dent* 1997; 25(3-4): 321-30.
18. Neiva IF, De Andrada MAC, Baratieri LN *et al.* An in vitro study of the effect of restorative technique on marginal leakage in posterior composites. *Oper Dent* 1998; 23(6): 282-89.
19. Nomoto R, Uchida K, Hirasawa T. Effect of light intensity on polymerization of light-cured composite resins. *Dent Mater J* 1994; 13(2): 198-205.
20. Ota K, Kopel HM, Nakamura RM *et al.* Effect of light exposure time on the depth of curing in various composite resin systems. *Pediat Dent* 1985; 7(1): 19-22.
21. Pimenta LAF. Avaliação da microinfiltração em restaurações de classe II em compósito realizadas com duas técnicas diferentes de inserção. Piracicaba [Tese Livre Docência]. Piracicaba: Faculdade de Odontologia da UNICAMP; 1999.

22. Uno S, Asmussen E. Marginal adaptation of a restorative resin polymerized at reduced rate. *Scand J Dent Res* 1991; 99(5): 440-4.
23. Unterbrink GL, Muessner R. Influence of light intensity on two restorative systems. *J Dent* 1995; 23(3): 183-9.

Tabela 1 - Frequências de escores de infiltração marginal em função da ativação e da técnica de inserção.

Ativação	Técnica de Inserção	Infiltração (escores)					Total Global
		0	1	2	3	4	
Convencional	incremento único	23	7	0	0	0	30
Convencional	3 incrementos	19	7	1	0	2	29
"Soft-start"	incremento único	15	12	0	0	0	27
"Soft-start"	3 incrementos	20	10	1	0	0	31
Progressiva	incremento único	16	13	0	1	0	30
Progressiva	3 incrementos	17	12	1	0	1	31
Total Global		110	61	3	1	3	178

Tabela 2 - Microdureza em função da técnica de inserção, da ativação e da profundidade da restauração.

Técnica de Inserção	Ativação	Distância da parede gengival						Média Geral
		100 µm		2.500 µm		5.000 µm		
		média	DP	média	DP	média	DP	
Incremento único	Convencional	139	26	143	28	150	34	144 A
Incremento único	"Soft-start"	137	20	143	23	143	21	141 A
Incremento único	Progressiva	130	15	134	11	132	9	132 B
Média		136 b		140 ab		142 a		
3 Incrementos	Convencional	140	26	147	24	144	23	144 A
3 Incrementos	"Soft-start"	144	17	140	15	145	19	143 A
3 Incrementos	Progressiva	129	7	131	9	135	5	132 B
Média		138 b		139 ab		141 a		

DP = Desvio Padrão

Médias seguidas de letras distintas (maiúsculas na vertical e minúsculas na horizontal), dentro de cada técnica, diferem entre si pelo teste de Tukey ($p < 0,05$).

Não houve diferença significativa entre as técnicas de inserção ($p > 0,05$).



Figura 1 - A: Posição de seccionamento dos dentes bovinos (5 mm acima da junção cemento-esmalte); B: Localização e dimensões dos preparos cavitários: 1 mm abaixo da JCE (extensão ocluso-cervical de 6 mm), 3 mm de largura e 1,5 mm de profundidade.



Figura 2 - Descrição da técnica de inserção em incrementos vestibulo-linguais. A: primeiro incremento; B: segundo incremento; C: terceiro incremento.

3.2. Capítulo II

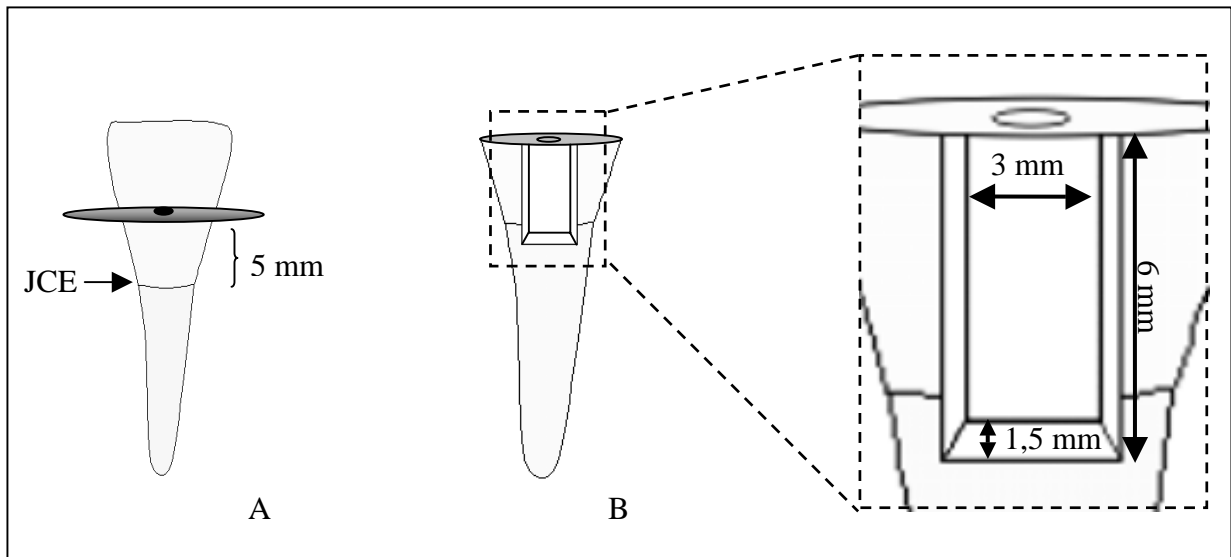
Microleakage and gap formation of resin composite restorations polymerized with different techniques

Aceito para publicação na revista American Journal of Dentistry

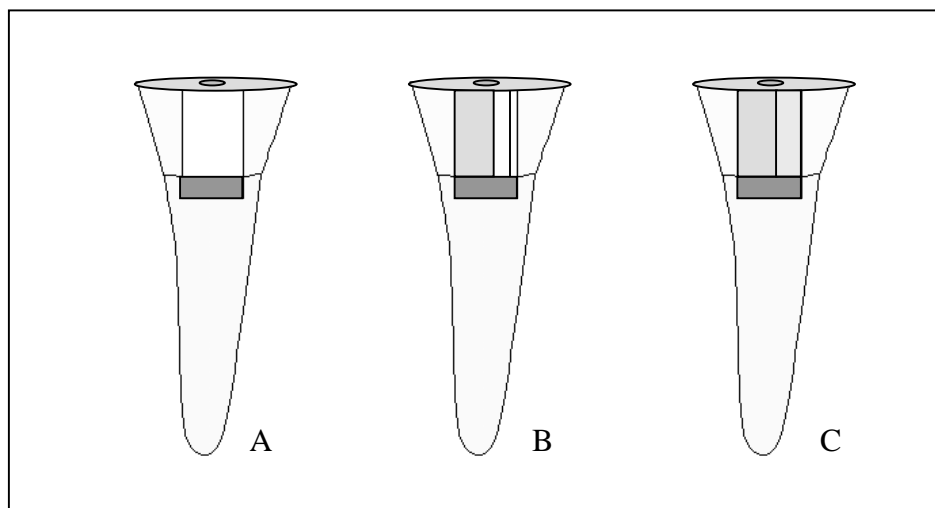
Microleakage and gap formation of resin composite restorations polymerized with different techniques

Cristiane Mariote Amaral, DDS, MS¹; Alessandra Rezende Peris, DDS¹; Luiz André Freire Pimenta, DDS, MS, PhD²; Glaucia Maria Bovi Ambrosano, DDS, MS, PhD³.

1 - Graduate Student, Department of Restorative Dentistry, School of Dentistry of Piracicaba, University of Campinas (UNICAMP), Piracicaba, Brazil.

2 - Associate Professor, Department of Restorative Dentistry, School of Dentistry of Piracicaba, University of Campinas (UNICAMP), Piracicaba, Brazil.

3 - Assistant Professor, Department of Social Dentistry - Biostatistic, School of Dentistry of Piracicaba, University of Campinas (UNICAMP), Piracicaba, Brazil.

Correspondence:

Professor Luiz André Freire Pimenta

Restorative Dentistry, School of Dentistry of Piracicaba - UNICAMP

Av. Limeira, 901 – Areião, Piracicaba - SP, Brazil.

CEP 13414-018

Fax: 55-19-3412-5218.

Phone: 55-19-3412-5340.

e-mail: lpimenta@fop.unicamp.br

Abstract: *Purpose:* The aim of this study was to evaluate the effect of different polymerization techniques on microleakage and gap formation of composite resin restorations. One correlation test was also carried out between these methodologies. ***Materials and Methods:*** One hundred eighty vertical slot cavities were prepared in bovine teeth and filled with Z250/Single Bond system (3M), for the following groups (n=30): Soft-start I - 10 s at 75 mW/cm² + 30 s at 560 mW/cm²; Soft-start II - 10 s at 190 mW/cm² + 30 s at 560 mW/cm²; Pulse delay - 3 s at 300 mW/cm² + 5 min waiting + 30 s at 560 mW/cm²; Plasma arc - 3 s at 1,500 mW/cm²; High intensity - 40 s at 810 mW/cm²; Conventional - 40 s at 560 mW/cm². After polishing, epoxy replicas were prepared for electron microscopy analysis (n=10), at x500 magnification. The samples were thermocycled, new epoxy replicas were prepared, and the teeth were immersed in 2% methylene blue dye solution for 4 hours. Marginal gaps were evaluated again and the microleakage was assessed. ***Results:*** No statistical difference among polymerization techniques was observed for microleakage (Kruskal-Wallis test). For gap formation there was no statistical difference among polymerization techniques either before or after thermocycling (Tukey test). Conversely, thermocycling increased significantly the gap formation for all groups. No correlation (Spearman correlation test) was observed for the results of microleakage and gap formation.

Clinical Significance: Soft-start, pulse delay, plasma arc, and high intensity polymerization techniques did not reduce the microleakage and the gap formation when compared with conventional technique. However, gap formation increased after thermocycling for all groups.

Introduction

Light activated resin-based composites (RBC) have revolutionized clinical dentistry because of the increased esthetic demands.^{1,2} However, the RBC presents an inherent disadvantage: polymerization shrinkage during setting.^{2,3}

The polymerization shrinkage of RBC can create significant stress in the surrounding tooth structure and it may disrupt the bond to cavity walls,^{4,5} leading to bond failure and subsequent post-operative sensitivity, microleakage, and secondary caries.^{6,7}

Many techniques have been studied to reduce shrinkage stress, such as soft-start polymerization,^{1,2,3,8,9} pulse delay,^{1,10} and reduced light intensity polymerization.^{11,12,13} The soft-start polymerization technique involves an initial cure at low light intensity followed by final cure at high intensity.¹ The pulse delay cure consists of an initial low intensity, a waiting period when surface finishing may be performed, followed by curing at a high intensity.¹⁴ These slow polymerization reactions influence flow characteristics and may be useful in moderating the development of shrinkage stress and in improving marginal adaptation.^{2,9,11,12} However, other studies have found no significant improvement in marginal adaptation with soft-start polymerization.^{8,15} Also, no significant reduction was observed in polymerization shrinkage with this method^{1,3} or with pulse delay.¹

A new type of light curing system, plasma arc curing (PAC) unit, was introduced.¹⁶ Light is emitted in high intensity from a glowing plasma that is composed of a gaseous mixture of ionized molecules and electrons.¹⁷ The PAC unit

is attractive to the practitioner because the time spent polymerizing RBC restorations can be reduced up to 75%.¹⁸ Long cure time is inconvenient for the patient, impractical with children and uncomfortable for the dentist.¹⁷ Some studies^{16,17} have shown that the PAC units had equal or less polymerization shrinkage than the conventional unit. Although the PAC units caused no damage to the marginal integrity of dentin cavities,¹⁹ another study¹⁸ observed a greater incidence of microleakage in restorations cured by PAC unit.

The aim of this study was to evaluate the effect of soft-start, pulse delay, plasma arc, high intensity (halogen lamp), and conventional polymerization techniques on microleakage and gap formation of resin composite restorations. The influence of thermocycling on gap formation was evaluated as well as the correlation between microleakage and gap formation tests.

Materials and Methods

Ninety extracted bovine incisor teeth were initially stored in a saline solution containing 0.5% sodium azide, and next debris were removed from the teeth. The crowns of the bovine teeth had been cut off 5 mm above the cemento-enamel junction (CEJ), with a double-faced diamond disk^a.

“Slot” type Class II cavities at the mesial and lingual surfaces were prepared with carbide burs^b in a high-speed water-cooled hand piece. Burs were replaced after every 5 preparations to maintain uniformity. Butt-joint cavities had the following dimensions: 1.5 mm of depth by 3 mm of bucco-lingual width; gingival margin was located 1mm apical to the CEJ.

In all groups, enamel and dentin etching with 35% phosphoric acid^c was performed for 15 s. Single Bond^c adhesive system was applied following the manufacturer's instructions.

Z250^c RBC (shade A2) was inserted by instrument placement in three horizontal increments and they were polymerized on the occlusal surface according to the following groups: G1: Soft-start I - 10 s at 75 mW/cm² + 30 s at 560 mW/cm²; G2: Soft-start II - 10 s at 190 mW/cm² + 30 s at 560 mW/cm²; G3: Pulse delay - 3 s at 300 mW/cm² + 5 min delay + 30 s at 560 mW/cm²; G4: Plasma arc - 3 s at 1,500 mW/cm²; G5: High intensity (halogen lamp) - 40 s at 810 mW/cm²; G6: Conventional (Control)- 40 s at 560 mW/cm². The groups are described in Table 1.

In G3 (pulse delay), the first and second increments were polymerized for 3 s at 300 mW/cm² and the last increment was polymerized for 3 s at 300 mW/cm², followed by 5 min waiting, and then it was polymerized for 30 s at 560 mW/cm².

Following the restorative procedures, the teeth were stored in a humid environment at 37°C for 24 hours. After this time, all restorations were finished with Sof-Lex^c medium, fine, and ultrafine finishing disks.

After the polishing, impressions of cervical margins were made with a polyether impression material^g. Epoxy replicas^h (n=10) were prepared for scanning electron microscopy (SEM) analysis to document the margin before thermocycling.

All specimens were then thermocycled in a thermal cycling machineⁱ for 1,000 cycles at 5 ± 2°C and 55 ± 2°C with a dwell time of 60 s in distilled water with

a 5 s transfer time. Again, epoxy replicas for SEM analysis were prepared to document the margin after thermocycling.

Surfaces of the epoxy replicas were sputter-coated with gold^j and the cervical margins were divided in three regions for SEM analysis. The margins were evaluated at x500 magnification with a scanning electron microscope^k and the maximum marginal gap of each region was recorded. The mean of gaps for each restoration was calculated.

For microleakage evaluation, the apices and coronal surfaces were sealed with epoxy resin^l and the teeth were double coated with fingernail polish up to 1 mm from the gingival margins. All teeth were immersed in a freshly prepared aqueous solution of 2% methylene blue (pH 7.0) for 4 hours and then rinsed. Finally, each tooth was sectioned vertically through the center of the restoration with a diamond disk at low-speed.

Microleakage at the gingival margin was evaluated by three examiners with an optical stereomicroscope at x60 magnification and scored using the following criteria:

- 0 - No dye penetration
- 1 - Dye penetration that extended for less than or up to 1/3 of cavity depth
- 2 - Dye penetration greater than 1/3 or up to 2/3 of cavity depth
- 3 - Dye penetration greater than 2/3 of cavity depth
- 4 - Dye penetration attaining or passing the axial wall.

The Weighted Kappa Test of Reproducibility evaluated the agreement

among examiners. The median of the microleakage evaluation of the three examiners was submitted to the Kruskal-Wallis test at 5% level of significance ($\alpha=0.05$) in order to evaluate the differences among the experimental groups.

Data of marginal sealing (SEM) were analyzed with split-plot ANOVA and Tukey tests ($\alpha=0.05$), which were used to compare marginal gap of groups and marginal gaps before and after thermocycling.

Results

The agreement among examiners was excellent. The weighted Kappa estimator was 0.90.

The distribution of microleakage scores for each group is shown in Table 2. For microleakage test, no significant difference ($p>0.05$) was observed among the polymerization techniques used.

There was no significant difference ($p>0.05$) among the polymerization techniques used, for analysis of gap formation (Figs. 1-6). However, the thermocycling significantly caused more gap formation for all groups (Table 3).

The Spearman Correlation Coefficients ($\alpha=0.05$) showed no correlation between the microleakage and the gap formation tests ($p=0.6735$).

Discussion

Dye penetration is one of the oldest and most common methods used for “in vitro” studies of microleakage in restorations.^{20,21,22} The excellent agreement among the examiners demonstrates the reliability of the dye penetration technique in the evaluation of marginal microleakage when adequate calibration of the

examiners is performed.

The use of SEM provides a means of direct visual observation of the adaptation of restorative materials to cavity margins because of its high magnification and depth of focus.^{20,21,22} The SEM technique can be criticized for its potential for introducing errors and artifacts during specimen preparation as drying, cracking, and distortion.^{20,21,22} The use of a replica technique may overcome this problem, allowing no change in the size of marginal defects.^{21,22} Furthermore, replicas may be repeated many times at different intervals.²²

Therefore, these two methodologies, microleakage and SEM, were performed to compare the different polymerization techniques: soft-start, pulse delay, plasma arc, high intensity with halogen lamp, and conventional halogen lamp.

In the present study there were no significant differences among the polymerization techniques in microleakage and SEM analyses.

It has been emphasized that reduced light intensity may significantly improve marginal integrity,^{11,12,13} and the soft-start polymerization might result in restorations with improved marginal adaptation without loss in the quality of material.²

However, the soft-start techniques, with two initial intensities (G1 and G2), did not result in improved marginal adaptation or less microleakage. The results of marginal adaptation of this study are in disagreement with other studies^{2,9} which observed decrease of gap formation with soft-start polymerization. In the study of Uno & Asmussen,⁹ improvement in marginal adaptation occurred only

when RBC was initially polymerized for 30 s at low intensity.

The results of this study are in agreement with other studies.^{8,15,23} The soft-start polymerization did not reduce the gap formation^{8,15} and the microleakage^{15,23} in RBC restorations.

Other studies^{1,3,12} observed no significant reduction in polymerization shrinkage with the soft-start polymerization.

Although Mehl *et al.*² found improvement in marginal adaptation with soft-start polymerization, in the microleakage evaluation the authors did not observe significant difference between conventional or soft-start polymerization, as in this study.

Other studies^{23,24} have found no significant differences in microleakage evaluation when different polymerization techniques were used. Burmann *et al.*²⁴ observed that progressive intensity polymerization technique had no influence on microleakage. The restorative system (adhesive/resin composite) used was more critical than the polymerization technique, affecting significantly the microleakage.

This is in agreement with study of Alonso *et al.*,²³ who found no difference among conventional, soft-start, and pulse cure polymerization techniques in microleakage test, but they found significant difference among RBCs used. Martinez *et al.*²⁵ observed that the soft-start polymerization technique reduced the microleakage when the Z100 RBC was used. However, no significant difference between the soft-start or conventional polymerization techniques was observed for Alert RBC.

The gap formation and the microleakage of RBC restorations can be

influenced by adhesive system and RBC. ^{17,19} Some restorative materials can be more dependent on light intensity than others. ¹² Z100 RBC, for example, showed a high dependence on light intensity, and for Tetric RBC two bonding agents were relatively effective at both light intensities 250 or 450 mW/cm². ¹² The soft-start polymerization might be useful to reduce gap formation and microleakage for RBCs that present greater polymerization shrinkage, permitting greater flow and reducing the stress at interface. In this study only one resin composite was tested and other materials might behave differently.

In regards to pulse delay polymerization, Cardoso *et al.* ¹⁰ found no significant difference in microleakage when the conventional and pulse delay (300 mW/cm² - 3 s, waiting time of 5 min, 500 mW/cm² - 30 s) techniques were compared. Walker & Burgess ²⁶ also found no significant difference among ramp-curing, pulse delay (100 mW/cm² - 3 s, waiting time of 3 min, 400 mW/cm² - 30 s), and conventional polymerization techniques in microleakage evaluation, with gingival margins in cementum. The results of the present study are in agreement with the studies mentioned.

On the other hand, Yap *et al.* ¹ observed that the pulse delay I technique (100 mW/cm²- 3 s, waiting time of 3 min, 500 mW/cm² - 30 s) showed less polymerization shrinkage than soft-start, pulse cure, and pulse delay II (200 mW/cm²- 20 s, waiting time of 3 min, 500 mW/cm² - 30 s) techniques.

Other two factors may also affect the RBC polymerization: the rate of cure and the degree of conversion. ¹⁷ A high cure rate tends to increase the size of marginal gap because the material stiffens rapidly restricting its flow. ^{9,11,17} Thus, a

tendency towards the increase in size of the marginal gaps and in microleakage could be expected with the high intensity of PAC units. However, this did not occur in this study nor in other studies.^{16,17,19} When the degree of conversion is less than the maximum, it will tend to reduce the shrinkage, and the PAC polymerization technique presents a relatively small degree of conversion.¹⁷ Thus, with the PAC polymerization, it may be argued that the rapid cure is compensated by the low degree of conversion resulting in gaps similar to conventional polymerization.¹⁷

Peutzfeldt *et al.*¹⁷ compared the gap formation in RBC restorations using two PAC units and conventional halogen lamp. For all adhesive/RBC combinations, the light curing units showed similar gap formation, except in one case: when the Apollo 95E showed less gap formation than the halogen lamp.¹⁷ Again the influence of restorative material in polymerization shrinkage was observed.

The results of this study are also in agreement with the study of Hasegawa *et al.*¹⁹ They observed no significant difference among two PAC units and conventional halogen lamp in gap formation evaluation.

The PAC unit may cause less polymerization shrinkage than conventional polymerization (halogen lamp), as Park *et al.*¹⁶ observed for two RBC tested. However, Brackett *et al.*¹⁸ observed significant greater microleakage for PAC polymerization than conventional polymerization, in class V restorations, with gingival margins in cementum.

In the present study the conventional and the high intensity polymerization techniques (both with halogen lamp) presented similar results for gap formation and microleakage. The difference of light intensity probably was not

high enough to affect the polymerization shrinkage and consequently it did not affect the marginal sealing.

After thermocycling, a significant increase in gap formation was observed for all polymerization techniques. Thermocycling is very important because it is the *in vitro* procedure of subjecting a restoration and tooth to extreme temperatures such as those found in oral cavity.²² The thermocycling is also important due to the difference between the coefficients of thermal expansion of the tooth and RBC. Other studies^{27,28,29} have also observed the importance of thermocycling in microleakage evaluation because the thermal stress increased the marginal leakage. However, Rossomando & Wendt Jr³⁰ found no significant difference in extent of dye penetration in the tooth/restoration interface for the thermocycled RBC restorations when compared with no thermocycling.

This study evaluated the correlation between the results of microleakage and the gap formation tests. The gaps were evaluated externally with the use of replica, as in other studies.^{2,12,15} No correlation was observed between the results of these tests ($p > 0.05$). Although a gap may appear large externally, it is not possible to know the depth of a gap towards the axial wall, whereas the microleakage evaluates the depth of dye penetration. As these methodologies evaluate different areas, the absence of correlation may be easily understood. Mehl *et al.*² also evaluated the gap formation and microleakage and found different results in each methodology, but no statistical test of correlation was done. Other authors^{11,13} preferred to do replicas of sectioned restorations in order to evaluate the depth of gaps toward the axial wall.

Calculations of energy density as the product of light intensity (in mW/cm²) and time (in s) showed that the energy density for PAC (4.5 J/cm²) was the lowest for all polymerization techniques (Table 1). The high intensity polymerization with halogen lamp showed the highest energy density (32.4 J/cm²). These variations in energy density were probably insufficient to influence the gap formation and microleakage. The energy density alone may not be a good predictor of the polymerization shrinkage of RBC and the marginal sealing.

Although the restorative material and adhesive system may also influence the results of these tests and may affect the evaluation of polymerization shrinkage, in this study, soft-start, pulse delay, plasma arc, high intensity, and conventional polymerization techniques presented similar behavior in preventing gap formation and microleakage.

- a. KG Sorensen, São Paulo, SP, Brazil.
- b. FG 245, Metalúrgica Fava, São Paulo, SP, Brazil.
- c. 3M Dental Products, St. Paul, MN, USA.
- d. Variable Intensity Polymerizer, Bisco Inc, Schaumburg, IL, USA.
- e. DMD Corp, West Lake Village, CA, USA.
- f. Demetrom/Kerr Corp, Danbury, CT, USA.
- g. Impregum F, Espe Dental, Seefeld, Bavaria, Germany.
- h. Epoxide Resin, Buehler, Lake Bluff, IL, USA.
- i. Instrumental Instrumentos de Precisão Ltda, São Paulo, SP, Brazil.
- j. Desk II cold sputter/etch unit, Denton Vacuum Inc, Moorestown, NJ, USA.
- k. Scanning Electronic Microscopy JSM 5600SLV, Jeol Datum, Tokyo, Japan.
- l. Araldite, Brascola Ltda, São Bernardo do Campo, SP, Brazil.

Acknowledgements

The authors gratefully acknowledge the support from Fundação de Amparo à Pesquisa do Estado de São Paulo (FAPESP - Grant 00/13681-6 and Grant 01/05780-7), and also thank Mr. Adriano Luis Martins and Ms. Eliene A. O. Narvaes Romani, responsible by Scanning Electronic Microscopy Area at the Scholl of Dentistry of Piracicaba - UNICAMP.

References

1. Yap AUJ, Soh MS, Siow KS. Post-gel shrinkage with pulse activation and soft-start polymerization. *Oper Dent* 2002; 27: 81-87.
2. Mehl A, Hickel R, Kunzelmann KH. Physical properties and gap formation of light-cured composites with and without 'softstart-polymerization'. *J Dent* 1997; 25: 321-330.
3. Yap AUJ, Ng SC, Siow KS. Soft-start polymerization: influence on effectiveness of cure and post-gel shrinkage. *Oper Dent* 2001; 26: 260-266.
4. Davidson CL, de Gee AJ, Feilzer A. The competition between the composite-dentin bond strength and the polymerization contraction stress. *J Dent Res* 1984; 63: 1396-1399.
5. Feilzer AJ, de Gee AJ, Davidson CL. Setting stress in composite resin in relation to configuration of the restoration. *J Dent Res* 1987; 66: 1636-1639.
6. Davidson CL, Feilzer AJ. Polymerization shrinkage and polymerization shrinkage stress in polymer-based restoratives. *J Dent* 1997; 25: 435-440.
7. Eick JD, Welch FH. Polymerization shrinkage of posterior composite resins and its possible influence on postoperative sensitivity. *Quintessence Int* 1986; 17: 103-111.
8. Sahafi A, Peutzfeldt A, Asmussen E. Soft-start polymerization and marginal gap formation *in vitro*. *Am J Dent* 2001; 14: 145-147.
9. Uno S, Asmussen E. Marginal adaptation of a restorative resin polymerized

- at reduced rate. *Scand J Dent Res* 1991; 99: 440-444.
10. Cardoso PEC, Burmann PA, Soares LF *et al.* Microinfiltração em restaurações oclusais de resina composta fotopolimerizadas pela técnica do pulso atrasado. *Pesq Odontol Bras* 2000; 14: 66 (Abstr A047).
 11. Feilzer AJ, Dooren LH, de Gee AJ *et al.* Influence of light intensity on polymerization shrinkage and integrity of restoration-cavity interface. *Eur J Oral Sci* 1995; 103: 322-326.
 12. Unterbrink GL, Muessner R. Influence of light intensity on two restorative systems. *J Dent* 1995; 23: 183-189.
 13. Goracci G, Mori G, Martinis LC. Curing light intensity and marginal leakage of resin composite restorations. *Quintessence Int* 1996; 27: 355-362.
 14. Yap AUJ, Seneviratne C. Influence of light energy density on effectiveness of composite cure. *Oper Dent* 2001; 26: 460-466.
 15. Friedl KH, Schmaltz G, Hiller KA *et al.* Marginal adaptation of class V restorations with and without "soft-start" polymerization. *Oper Dent* 2000; 25: 26-32.
 16. Park SH, Krejci I, Lutz F. Microhardness of resin composites polymerized by plasma arc or conventional visible light curing. *Oper Dent* 2002; 27: 30-37.
 17. Peutzfeldt A, Sahafi A, Asmussen E. Characterization of resin composites polymerized with plasma arc curing units. *Dent Mater* 2000; 16: 330-336.
 18. Brackett WW, Haisch LD, Covey DA. Effect of plasma arc curing on the

- microleakage of class V resin-based composite restorations. *Am J Dent* 2000; 13: 121-122.
19. Hasegawa T, Itoh K, Yukitani W *et al.* Depth of cure and marginal adaptation to dentin of xenon lamp polymerized resin composites. *Oper Dent* 2001; 26: 585-590.
 20. Going RB. Microleakage around dental restorations: a summarizing review. *J Am Dent Assoc* 1972; 84: 1349-1357.
 21. Kidd EAM. Microleakage: a review. *J Dent* 1976; 4: 199-206.
 22. Alani AH, Toh CG. Detection of microleakage around dental restorations: a review. *Oper Dent* 1997; 22: 173-185.
 23. Alonso RCB, Sinhoreti MAC, Consani S *et al.* Efeito do método de polimerização sobre a infiltração marginal em restaurações com compósitos odontológicos. *Pesq Odontol Bras* 2000; 14: 55 (Abstr I353).
 24. Burmann P, Cardoso PC, Silveira B *et al.* O efeito de diferentes técnicas de fotopolimerização sobre a microinfiltração. *Pesq Odontol Bras* 2000; 14: 56 (Abstr A048).
 25. Martinez A, Falcon J, Garcia-Godoy F *et al.* Soft-start system polymerization using a hybrid composite vs packable composite: microleakage study. *J Dent Res* 2000; 79: 535 (Abstr 3133).
 26. Walker RS, Burgess JO. Microleakage of class V composite restorations with different curing methods. *J Dent Res* 2000; 79: 161 (Abstr 143).

27. Crim GA, Mattingly SL. Evaluation of two methods for assessing marginal leakage. *J Prosthet Dent* 1981; 45: 160-163.
28. Crim GA, Swartz ML, Phillips RW. Comparison of four thermocycling techniques. *J Prosthet Dent* 1985; 53: 50-53.
29. Momoi Y, Iwase H, Nakano Y *et al.* Gradual increases in marginal leakage of resin composite restorations with thermal stress. *J Dent Res* 1990; 69: 1659-1663.
30. Rossomando KJ, Wendt Jr SL. Thermocycling and dwell times in microleakage evaluation for bonded restorations. *Dent Mater* 1995; 11: 47-51.

Table 1. Polymerization techniques used in this study.

Groups	Polymerization Techniques	Energy Density	Light Curing Unit
Soft-start I	10 s at 75 mW/cm ² followed by 30 s at 560 mW/cm ²	17.55 J/cm ²	VIP ^d
Soft-start II	10 s at 190 mW/cm ² followed by 30 s at 560 mW/cm ²	18.7 J/cm ²	VIP
Pulse Delay	3 s at 300 mW/cm ² for each increment, delay (5 min), followed by 30 s at 560 mW/cm ² for the last increment	17.7 J/cm ²	VIP
Plasma Arc	3 s at 1,500 mW/cm ²	4.5 J/cm ²	APOLLO 95E ELITE ^e
High Intensity	40 s at 810 mW/cm ²	32.4 J/cm ²	OPTILUX 501 ^f
Conventional	40 s at 560 mW/cm ²	22.4 J/cm ²	OPTILUX 500 ^f

Table 2. Distribution of microleakage scores and medians for each group.

Groups	Scores					Median
	0	1	2	3	4	
Soft-start I	0	15	5	3	6	1 a
Soft-start II	0	16	1	3	8	1 a
Pulse Delay	0	9	4	5	12	3 a
Plasma Arc	1	15	5	2	7	1 a
High Intensity	0	16	2	4	8	1 a
Conventional	0	16	2	7	4	1 a

H=6.5188 p=0.2590

Medians followed by same letter are not statically different when analyzed by Kruskal-Wallis test ($\alpha=0.05$).

Table 3. Means of marginal gaps (μm) before and after thermocycling for each polymerization technique.

Groups	Before Thermocycling		After thermocycling	
	Mean (μm)	SD	Mean (μm)	SD
Soft-start I	4.00 A a	1.94	6.67 A b	3.02
Soft-start II	5.22 A a	3.41	7.36 A b	2.76
Pulse Delay	5.89 A a	2.33	6.96 A b	2.68
Plasma Arc	3.28 A a	1.84	4.96 A b	1.43
High Intensity	3.93 A a	2.50	5.59 A b	2.02
Conventional	4.56 A a	2.81	6.34 A b	2.65

Means followed by different letters were statistically different when analyzed by Tukey test ($\alpha=0.05$). Capital letters indicate comparisons among groups (in vertical). Small letters indicate comparison between samples before and after thermocycling within group (in horizontal).

SD = Standard Deviation

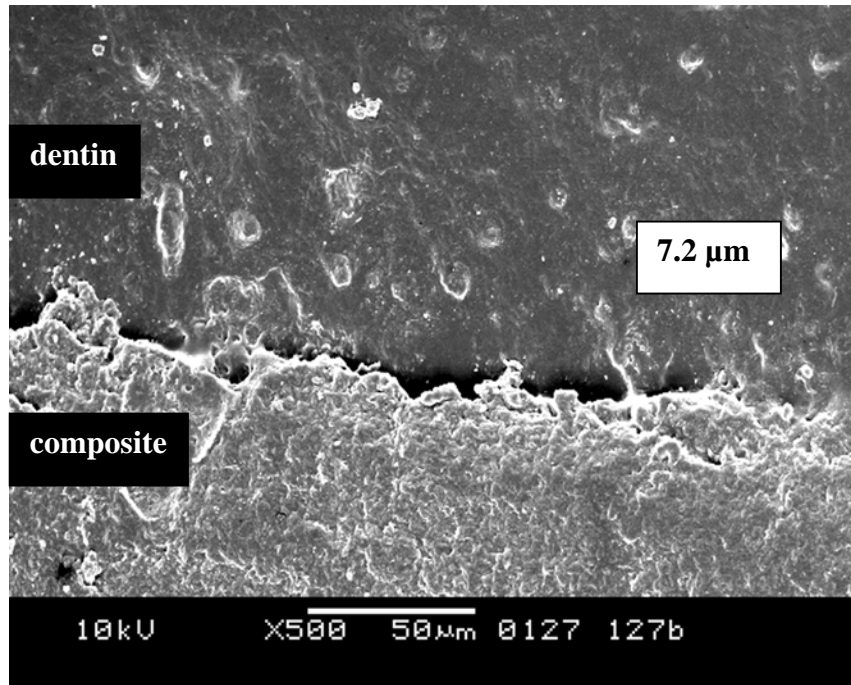

Fig. 1: Microscopy of marginal gap of a restoration polymerized by the technique Soft-start I.

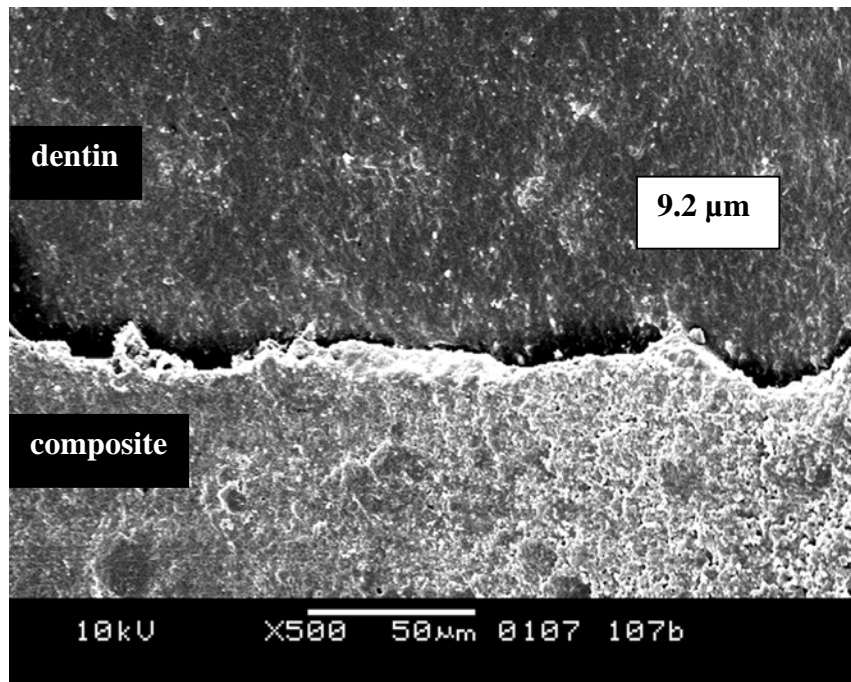

Fig. 2: Microscopy of marginal gap of a restoration polymerized by the technique Soft-start II.

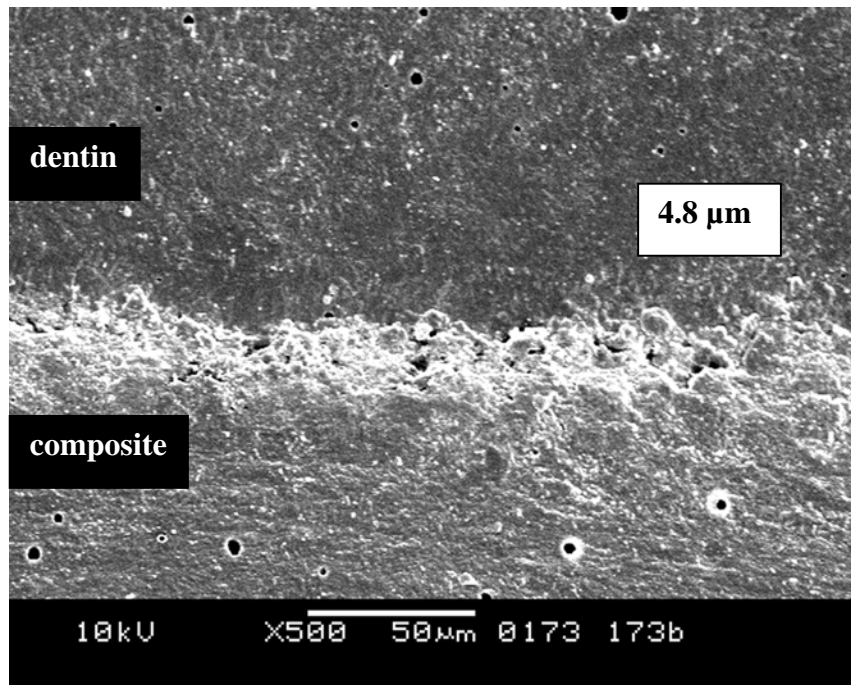

Fig. 3: Microscopy of marginal gap of a restoration polymerized by the technique Pulse Delay.

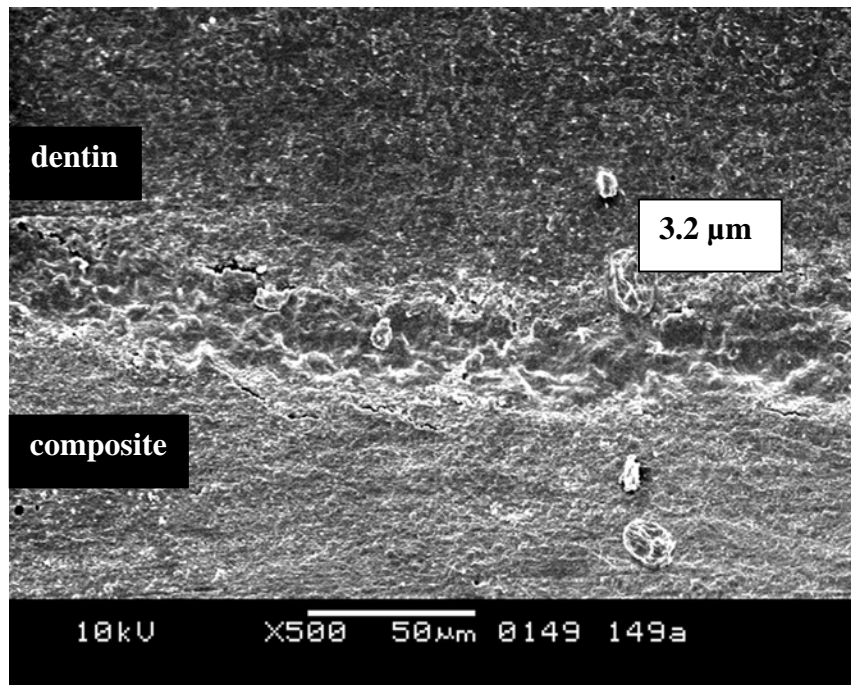

Fig. 4: Microscopy of marginal gap of a restoration polymerized by the technique Plasma Arc.

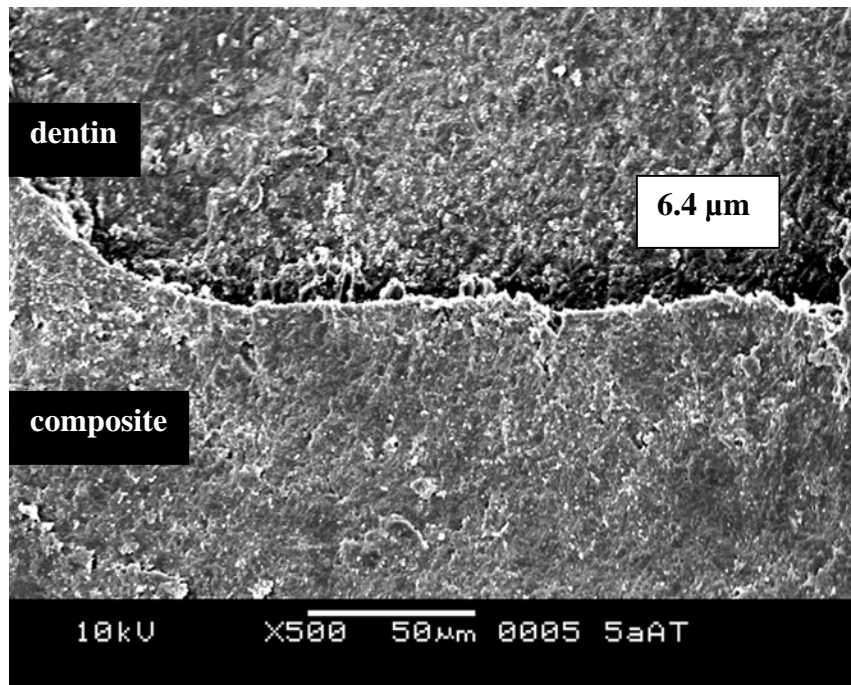

Fig. 5: Microscopy of marginal gap of a restoration polymerized by the technique High Intensity.

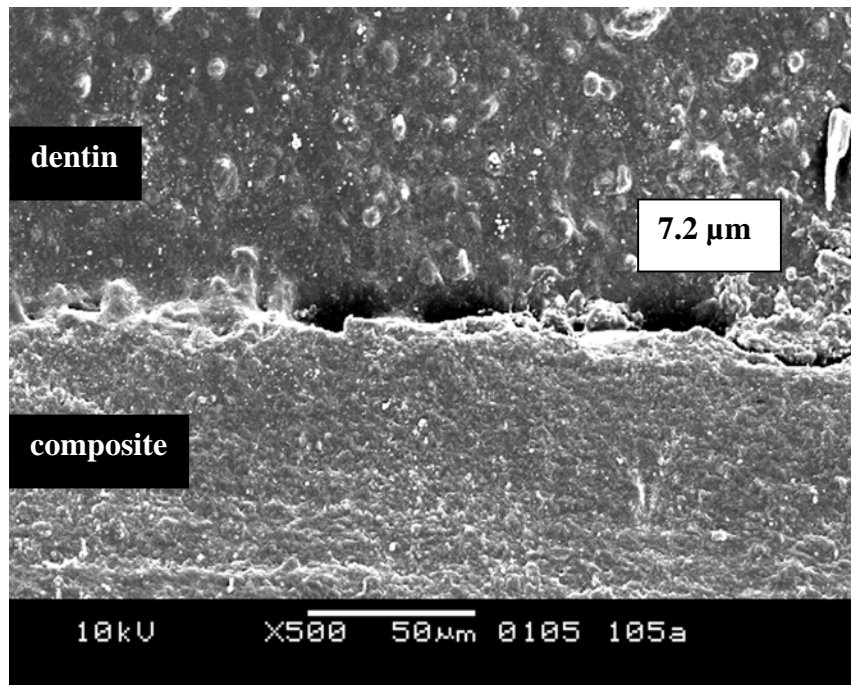

Fig. 6: Microscopy of marginal gap of a restoration polymerized by the technique Conventional.

3.3. Capítulo III

***Influence of polymerization technique on
microleakage and microhardness of resin composite
restorations***

Operative Dentistry 2003; 28(2): 198-204, mar/apr (no prelo)

Influence of polymerization technique on microleakage and microhardness of resin composite restorations

Larissa Maria Assad Cavalcante, DDS¹; Alessandra Rezende Peris, DDS²; Cristiane Mariote Amaral, DDS, MS³; Glaucia Maria Bovi Ambrosano MS, PhD⁴; Luiz André Freire Pimenta DDS, MS, PhD⁵.

1 - Research Assistant, Department of Restorative Dentistry, School of Dentistry of Piracicaba, University of Campinas, Piracicaba, São Paulo, Brazil.

2 - Graduate student, Department of Restorative Dentistry, School of Dentistry of Piracicaba, University of Campinas, Piracicaba, São Paulo, Brazil.

3 - Graduate Student, Department of Restorative Dentistry, School of Dentistry of Piracicaba, University of Campinas, Piracicaba, São Paulo, Brazil.

4 - Assistant Professor of Bioestatics, University of Campinas, Piracicaba, São Paulo, Brazil.

5 - Associate Professor of Restorative Dentistry, School of Dentistry of Piracicaba, University of Campinas, Piracicaba, São Paulo, Brazil.

Address all correspondence to:

Professor Luiz André Freire Pimenta

Restorative Dentistry, School of Dentistry of Piracicaba - UNICAMP

Av. Limeira, 901 – Areião, Piracicaba - SP, Brazil.

CEP 13414-018

Fax: 55-19-3412-5218.

Phone: 55-19-3412-5340.

e-mail: lpimenta@fop.unicamp.br

Clinical Relevance: The conventional technique for polymerization, used in association with a “packable” resin composite, provides similar resin-tooth interfacial seal to *Soft-*

Start and better seal when compared to PAC; however for a microhybrid resin composite, all techniques for polymerization present the same result.

Summary: The aim of this study was to evaluate the influence of three polymerization techniques on microleakage and microhardness of class II restorations using a microhybrid (Filtek Z250) and a “packable” composite resin (SureFil). The techniques, their respectively light intensities and time used in relation to resin composites, are: Conventional (C) - 800 mW/cm² for 40 seconds; Soft-Start (SS1) - 75 mW/cm² for 10 seconds plus 518 mW/cm² for 30 seconds; Soft-Start (SS2) - 170 mW/cm² for 10 seconds plus 518 mW/cm² for 30 seconds and Plasma Arc Curing (PAC) – 1,468 mW/cm² for 3 or 6 seconds. One hundred and fifty-two “Vertical Slot type Class II cavities” at the mesial and distal surfaces were prepared and divided into eight groups (n=19). After the restorative procedures, the samples were thermocycled (1,000 cycles at 5°C and 55°C), then immersed in 2% methylene blue dye solution for four hours. The microleakage was evaluated and the results analyzed by the Kruskal-Wallis and Multiple Comparisons tests. Ten samples from each group were randomly selected, embedded in polyester resin, polished and submitted to the Knoop microhardness test. ANOVA (split-plot) and Tukey’s test (p<0.01) revealed significant differences among depths: the hardness at the top surface was significantly higher followed by the middle and bottom surfaces. There was no significant difference in microleakage among the techniques when microhybrid resin composite was employed. However, when using a “packable” resin composite, the conventional technique for polymerization was comparable to Soft-Start and better than PAC.

Introduction

Since their introduction to the market in the 1970s, light curing resin composites have been used for restorations, making dental procedures more

conservative and able to serve esthetic demand. However, some material shortcomings such as reduced wear resistance, marginal staining and excessive polymerization shrinkage and the sensitivity of the technique, have not been eliminated despite extensive research (Leinfelder, 1995). The success of the clinical performance of light curing resin composites is directly related to adequate polymerization and light intensity, which are crucial factors in obtaining optimal physical properties (Bayne, Heyman & Swift, 1994).

During the setting process, the polymerization shrinkage of a resin composite can create forces that may disrupt the bond to cavity walls (Davidson, De Gee & Feilzer, 1984; Donly & others, 1987; Carvalho & others, 1996). This competition between contracting forces built up in the polymerizing resin and the bonds of adhesive resins to the wall of the restoration is one of the main causes of marginal failure and subsequent microleakage (Davidson & others, 1984; Mandras, Retief & Russel, 1991). Bond strength must be greater than contraction stress in order to obtain stable marginal adaptation. Microleakage permits the passage of bacteria, fluids, molecules and toxins and could encourage dentinal hypersensitivity, pulp inflammation, secondary caries and pulp necrosis (Kidd, 1976; Opdam & others, 1998).

Some studies have shown a relation between polymerization shrinkage and light intensity (Feilzer & others, 1995; Silikas, Eliades & Watts, 2000). As a result, different light units have been introduced into the market to minimize or control the polymerization shrinkage of composites.

Conventional lamps instantly provide maximal light intensity, which causes the resin composites to harden and produce a considerable increase in viscosity of the material (Goracci, Mori & Martinis, 1996). Composites cured at low light intensity have been shown to have a better marginal adaptation (Mandras & others, 1991; Uno & Asmussen, 1991). The theory is that a slower rate of conversion maintains a longer pre-gel phase, thereby, allowing for a better flow of the material, which, in turn, decreases contraction stress in the filling material. However, this low intensity may affect the surface hardness and may be insufficient for ensuring mechanical stability (Unterbrink & Muessner, 1995; Pimenta, 1999).

Pre-polymerization at low intensity, followed by the final cure at high intensity, can allow for the flow of resin composite during setting. This method (Soft-Start) can reduce the width and length of marginal gaps without interfering with the physical properties of the restorations (Uno & Asmussen, 1991; Mehl, Hickel & Kunzelman, 1997).

Now available, high intensity light units based on a plasma system can reduce the long cure time and provide optimal properties in resin composite in a few seconds (Peutzfeldt, Sahafi & Asmussen, 2000; Park, Krejci & Lutz, 2002). However, the use of units with such high intensities could create more contraction forces and, consequently, marginal fail (Bracket, Haisch & Covey, 2000).

New methods of polymerization with varying intensities and curing times are on the market; therefore, it is necessary to analyze the effectiveness in the control of marginal adaptation and the quality of polymerization. This study evaluated the microleakage and microhardness of Class II resin composites using

three available polymerization techniques - Conventional (Optilux 501, Demetrom/Kerr, Danbury, CT 06810, USA), Plasma Arc Curing (PAC, APOLLO 95E Elite, DMD Corp, Westlake Village, CA 91362, USA)) and Soft-Start (Variable Intensity Polymerizer, Bisco Inc, Schaumburg, IL 60193, USA) - and two different resin composites - a microhybrid (Filtek Z250, 3M Dental Products, St Paul, MN 551443, USA) and a “packable” (SureFil, Dentsply/Caulk-Milford, DE 19963, USA).

Methods and Materials

Microleakage Test

Seventy-six extracted bovine incisor were initially stored in a 2% formaldehyde buffered solution (Eick & Welch, 1986; Bedran de Castro, Hara & Pimenta, 2000; Gallo *et al*, 2001), after which debris was removed from the teeth. The crowns of the bovine teeth had been cut off 5 mm above the cement-enamel junction (CEJ) with a double-faced diamond disk (KG Sorensen Ind Com Ltda, Barueri, SP 06442-110, Brazil).

“Vertical Slot type Class II cavities” at the mesial and distal surfaces were prepared with #245 carbide burs (KG Sorensen Ind. Com. Ltda, Barueri, SP 06442-110, Brazil) with a high-speed water-cooled handpiece (Kavo do Brasil AS, Joinville, SC 89221-040, Brazil). The burs were replaced after every 10 preparations to maintain uniformity. Butt-joint cavities had the following dimensions: 1.5 mm axial deep by 3 mm bucco-lingual wide and the gingival margin was located 1 mm apical to the CEJ.

In all groups, enamel and dentin etching with 35% phosphoric acid was performed for 15 seconds. The Single Bond (3M Dental Products) adhesive system was applied following manufacturer's instructions. The resin composites SureFil (Dentsply/Caulk) and Filtek Z250 (3M Dental Products) were inserted in three horizontal increments and each increment was polymerized on the occlusal surface according to the following groups (n=19):

GROUP 1: SureFil (Dentsply/Caulk) resin composite and Conventional (C) polymerization technique for 40 seconds, each increment, showing an average intensity of 800 mW/cm²;

GROUP 2: SureFil (Dentsply/Caulk) resin composite using Soft-Start (SS1) polymerization technique (Variable Intensity Polymerizer, Bisco Inc) showing an average initial intensity of 75 mW/cm² for 10 seconds and 518 mW/cm² for the subsequent 30 seconds;

GROUP 3: SureFil (Dentsply/Caulk) resin composite using Soft-Start (SS2) polymerization technique (Variable Intensity Polymerizer, Bisco Inc) showing an average initial intensity of 170 mW/cm² for 10 seconds and 518 mW/cm² for the subsequent 30 seconds;

GROUP 4: SureFil (Dentsply/Caulk) resin composite using Plasma Arc Curing polymerization technique (PAC, APOLLO 95E Elite, DMD Corp), showing an average intensity of 1,468 mW/cm² for 6 seconds each increment, following manufacturer's instructions for this resin composite;

GROUP 5: Filtek Z250 (3M Dental Products) resin composite and Conventional (C) polymerization (Optilux501, Demetrom/Kerr) for 40 seconds each increment, showing an average intensity of 800 mW/cm²;

GROUP 6: Filtek Z250 (3M Dental Products) resin composite using Soft-Start (SS1) polymerization technique (Variable Intensity Polymerizer, Bisco Inc) showing an average initial intensity of 75 mW/cm² for 10 seconds and 518 mW/cm² for the subsequent 30 seconds;

GROUP 7: Filtek Z250 (3M Dental Products) resin composite using Soft-Start (SS2) polymerization technique (Variable Intensity Polymerizer, Bisco Inc) showing an average initial intensity of 170 mW/cm² for 10 seconds and 518 mW/cm² for the subsequent 30 seconds;

GROUP 8: Filtek Z250 (3M Dental Products) resin composite using Plasma Arc Curing polymerization technique (PAC, APOLLO 95E Elite, DMD Corp) showing an average intensity of 1,468 mW/cm² for 3 seconds for each increment, following manufacturer's instructions for this resin composite;

Following the restorative procedure, the teeth were stored in water at 37°C for 48 hours. All restorations were then finished with Sof-Lex (3M Dental Products) fine and ultra fine finishing disks and all specimens were thermocycled in a thermal cycling machine (MCT2-AMM instrumental, CA 94928, USA) for 1,000 cycles at 5 ± 2°C and 55 ± 2°C with a dwell time of 60 seconds in distilled water and a five-second transfer time. Next, the apices and coronal surfaces were sealed with epoxy resin (Araldite, Brascola Ltda, São Bernardo do Campo, SP 09771-190, Brazil) and the teeth were coated with two applications of fingernail

polish up to 1 mm from the gingival margins. All teeth were immersed in a freshly prepared aqueous 2% methylene blue solution (pH 7.0) for 4 hours at 37°C, then washed in water. Finally, each tooth was sectioned vertically through the center of the restoration with a diamond disk (KG Sorensen Ind Com Ltda) at low-speed.

Microleakage at the gingival margin was evaluated by two observers with an optical stereomicroscope (Meiji Techno Co, LTD, Iruma-gun Saitama 356, Japan) at 70x magnification and scored using the following criteria (Figure 1):

- 0 - No dye penetration.
- 1 - Dye penetration that extended up to 1/3 of preparation depth.
- 2 - Dye penetration greater than 1/3 up to 2/3 of preparation depth.
- 3 - Dye penetration extending to the axial wall.
- 4 - Dye penetration past the axial wall.

The results were analyzed by the Kruskal–Wallis and Multiple Comparisons tests.

Knoop Microhardness Test

After the microleakage evaluation, 10 sectioned restorations of each group were randomly selected and cut off with a double-faced diamond disk (KG Sorensen Ind Com Ltda). Twenty-six groups of three and one group of two restorations were placed in a ¾ inch diameter PVC ring filled with self-curing polystyrene resin (Piraglass, Piracicaba, SP 13424-550, Brazil). The embedded restorations were ground on a water-cooled mechanical grinder (Maxigrind, Solotest, São Paulo, SP 01328, Brazil) using 400, 600 and 1,000-grit Al₂O₃ abrasive

paper (Saint-Gobain Abrasivos Ltda., Guarulhos, SP 07111150, Brazil). The restorations were polished on a mineral oil-cooled grinder using felts with diamond pastes of 3 μm and 1 μm (Equilam, Diadema, SP 09960-500, Brazil).

The Knoop microhardness test (Microhardness Tester, Future Tech FM-1E, Future Tech Corp, Tokyo 140, Japan) was performed using a 25g load for 20 seconds. The indentations were placed at 100, 2,500 and 5,000 μm from the gingival margin, and at 100, 750 and 1,300 μm from the axial wall (Figure 2). The larger diagonal length of indentation was measured with a monitor (9M 100A Teli, Tokyo 140, Japan) and the values transformed in Knoop Hardness Numbers (KHN)

The microhardness means for each depth and for each experimental group were calculated and submitted to the ANOVA split-plot and Tukey's test that was used to compare Knoop microhardness among groups, depths and resin composites.

Results

Microleakage Test

None of the groups showed complete prevention of dye penetration. The results of statistical analysis are summarized in Table 1.

Analyzing the data, the SureFil (Dentispaly/Caulk) "packable" resin composite showed better results when using Conventional technique. The SS1 and SS2 techniques presented intermediate results, although they showed no statistical

differences from PAC, which demonstrated the worst scores. The Conventional technique for polymerization provided a similar resin-tooth interfacial to that of Soft-Start (Variable Intensity Polymerization, Bisco Inc) and better seal when compared to Plasma Arc Curing (PAC, Apollo 95E Elite, DMD Corp).

For Filtek Z250 (3M Dental Products) resin composite, there was no significant difference in leakage among the different methods of polymerization.

Knoop Microhardness Analysis

No significant differences in microhardness were observed between the resin composites ($p=0.1701$) and the C, SS1, SS2 and PAC unit polymerization techniques ($p=0.7103$).

The results did not show significant interaction among resin composites *vs* light units ($p=0.9111$), resin composites *vs* depth ($p=0.3511$), light units *vs* depth ($p=0.2646$) and light units *vs* resin composite *vs* depth ($p=0.4173$) in microhardness values.

The Tukey's test ($p<0.01$) revealed significant differences in microhardness in relation to depth/thickness of resin. Hardness at the top surface (5,000 μm) was significantly higher, followed by the middle (2,500 μm) and bottom (100 μm) surface, which showed the lower KHN means (Table 2). These findings were similar for both resins and curing techniques.

Discussion

Some techniques for reducing shrinkage stress and, consequently, marginal leakage have been suggested (Kays, Sneed & Nuckles, 1991). These include using reflexive wedges (Lutz & Barbakow, 1992), incremental restorative techniques (Tjan, Bergh & Lidner, 1992; Applequist & Meiers, 1996) and variations in light intensity (Uno & Asmussen, 1991; Feilzer & others, 1995; Unterbrink & Muessner, 1995). A lining material with a low-modulus of elasticity such as a glass ionomer (Aboushala & others, 1996), a new generation of dentin bonding (Goracci & others, 1995; Nakabayashi & Saimi, 1996) or a flowable composite lining, has

also been proposed by some authors, mainly in association with the “packable” resin composite (Konstantinos, 1998; Chuang, Liu & Jin, 2001).

The influence of using different kinds of light units with varying intensities during polymerization to reduce microleakage was evaluated in this study using a “packable” and a microhybrid resin composites.

None of the methods or restorative materials eliminate microleakage in face of the thermal changes and differences in the coefficient of thermal expansion between dental tissues and the restorative material. These results were also observed in other studies (Lieberman & Ben-Amar, 1996; Pimenta, 1999).

Both resins behaved differently when submitted to the same polymerization technique. While the microhybrid presented statistically similar results for all methods, the “packable” did not. In association with PAC units (G4) and SS2 (G3), the “packable” was statistically different in relation to C (G1) and SS1 (G2). The “packable” presented a high elasticity modulus what can cause more strain in the interface during polymerization (Davidson & others, 1984). Another reason may be that the “packable” composite may not adapt well to the dentin bonding agent and cavity preparation walls (Meiers, Kazemi & Meier, 2001).

The high microleakage scores that were found when the “packable” was compared to microhybrid might indicate that the filler particle technology of the “packable” composite could translate into increased post-gel linear shrinkage stress directed at the margins (Meiers & others, 2001). Stress arising from post-gel polymerization shrinkage may produce defects in the composite-tooth bond, leading to bond failure and, consequently, post-operative sensitivity, microleakage

and recurrent caries (Meiers & others, 2001; Yap, Soh & Siow, 2002). The more satisfactory results for the microhybrid resin when compared with the “packable” composite in this study could be explained by the lower post-gel shrinkage as revealed by the manufacturers.

Different studies have indicated that Soft-Start light curing units can be used to improve marginal integrity and decrease marginal gap (Uno & Asmussen, 1991; Goracci & others, 1996). However, according to results of this study, less leakage was not observed when the Soft-Start technique (Variable Intensity Polymerizer, Bisco Inc) was used in comparison with Conventional and Plasma Arc (PAC, Apollo 95E Elite, DMD Corp). Other studies also reported these results (Sahafi, Peutzfeldt & Asmussen, 2001; Yap, Ng & Siow, 2001; Yap & others, 2002). For both pre-polymerizations, starting with 75 mW/cm² (G2 e G6) or with 170 mW/cm² (G3 e G7), the groups presented no statistical differences between the resins. However, the association of the “packable” with SS2 (G3) was not similar to SS1 with the microhybrid resin (G6).

The “packable” resin composite cured with Plasma Arc curing (PAC, Apollo 95E Elite, DMD Corp), showed the highest leakage scores. However it was not statistically different from the Plasma Arc (PAC, Apollo 95E Elite, DMD Corp) with the microhybrid (G8), which behaved similarly with all techniques. Several studies have shown that high and fast curing rates tend to produce excessive polymerization stresses on adhesive bonds, resulting in poor marginal adaptation along gingival or dentinal margins (Uno & Asmussen, 1991; Mehl & others, 1997;

Brackett & others, 2000). This study's results seem to show that the low flow capacity of “packable” resin composite might be responsible for these values.

In this study, the microhardness of resin composites was measured in different depths as an indirect method for evaluating the relative degree of conversion (Mehl & others, 1997). The effective cure of resin composite is vital, not only to ensure optimum physical-mechanical properties (Asmussen, 1982), but also to ensure that clinical problems do not arise due to cytotoxicity of inadequately polymerized material (Caughman & others, 1991). In general, higher hardness values are an indication of more extensive polymerization (Helvatjoglou-Antoniad & others, 1991).

According to the results, the resin composites SureFil (Dentsply/Caulk) and Filtek Z250 (3M Dental Products) presented the same behavior when the C, SS1, SS2 and PAC unit polymerization techniques were used.

There was a significant difference in depth among the bottom (100 μ m), middle (2,500 μ m) and top (5,000 μ m) surfaces. For all techniques, microhardness was higher at the top surface. This can probably be explained because of the relationship between irradiation distance and effectiveness of polymerization (Pires & others, 1993). The depth of cure was reduced by increasing the distance between light tip and composite surface (Hansen & Asmussen, 1997). The degree to which light activated composite polymerization is proportional to the amount of light to which the material was exposed (Rueggeberg, Caughman & Curtis, 1994). The top surface of the material was nearer to the light force than the subsequent resin composite layers; in this way, the light transmission did not suffer any interference

and the intensity was not reduced. However, at the middle and bottom surfaces the light intensity was greatly reduced due to light scattering, thus, decreasing the effectiveness of polymerization (Ruyter & Oysaed, 1982). One way to compensate for this is to increase the light exposure time, which can provide better hardness results (Ota & others, 1985; Yap & others, 2001).

Although some studies demonstrated that 3 seconds of curing time was insufficient for optimal curing of composites when the Plasma Arc technique was used, (Park, Krejci & Lutz, 2002) the results found in this study showed similarities among C, SS1 and SS2 for the microhybrid resin composite.

Despite the great advances in light units that presenting new polymerization techniques, the conventional method is still preferred. Providing adequate polymerization and satisfactory infiltration scores, the Conventional method may be similar to Soft-Start and better than PAC, although each material had different characteristics.

Conclusions

The results of this study allow the authors conclude:

1. None of the techniques could eliminate microleakage;
2. For Filtek Z250 (3M Dental Products) microhybrid resin composite, all the polymerization techniques showed similar leakage results;
3. For SureFil (Dentsply/Caulk) "packable" resin composite, only the Soft-start polymerization technique (SS1) (Variable Intensity Polymerization, Bisco

Inc) with a 10-second initial intensity of 75 mW/cm², followed by 30 seconds at 518 mW/cm², decreased microleakage to levels similar to the Conventional technique;

4. All polymerization techniques presented similar results in microhardness values, but the top surface always presented high values followed by the middle and bottom surfaces.

Acknowledgments

The authors thank 3M (Brazil) and Dentsply (Brazil) for supplying the materials used in this study.

References

- Aboushala A, Kugel G & Hurley E (1996) Class II resin composite restorations using glass-ionomer liners: Microleakage studies *Journal of Clinical Pediatric Dentistry* **21(1)** 67-71.
- Appelquist EA & Meiers JC (1996) Effect of bulk insertion, prepolymerized resin composite balls, and beta-quartz inserts on microleakage of class V resin composite restorations *Quintessence International* **27(4)** 253-258.
- Asmussen, E (1982) Restorative resins: hardness and strenght vs quantity of remaining double bonds *Scandinavian Journal of Dental Research* **90(6)** 484-489.
- Bayne SC, Heyman HO & Swift EJ Jr. (1994) Update on dental composite restoration *Journal of American Dental Association* **125(6)** 687-701.
- Bedran de Castro AK, Hara AT & Pimenta LAF (2000) Influence of collagen removal on shear bond strength of one-bottle adhesive systems in dentin *The Journal of Adhesive Dentistry* **2(4)** 271-277.
- Brackett WW, Haisch LD & Covey DA (2000) Effect of plasma arc curing on the microleakage of class V resin-based composite restorations *American Journal of Dentistry* **13(3)** 121-122.
- Carvalho RM, Pereira JC, Yoshiyama M & Pashley DH (1996) A review of polymerization contraction: the influence of stress development versus stress relief *Operative Dentistry* **21(1)** 17-24.

Caughman WF, Caughman GB, Shiflett RA, Rueggeberg F & Scuster GS (1991) Correlation of cytotoxicity, filler loading and curing time of dental composites *Biomaterials* **12(8)** 737-740.

Chuang SF, Liu JK & Jin YT (2001) Microleakage and internal voids in class II composite restorations with flowable composite linings *Operative Dentistry* **26(2)** 193-200.

Davidson CL, De Gee AJ & Feilzer A (1984) The competition between the composite-dentin bond strength and the polymerization contraction stress *Journal of Dental Research* **63(12)** 1396-1399.

Donly KJ, Jensen ME, Reinhardt J & Walker JD (1987) Posterior composite polymerization shrinkage in primary teeth: an in vitro comparison of three restorative techniques *Pediatric Dentistry* **9(1)** 22-25.

Eick JD & Welch FH (1986) Polymerization shrinkage of posterior composite resin and its possible influence on postoperative sensitivity *Quintessence International* **17(2)** 103-111.

Feilzer AJ, Dooren LH, De Gee AJ & Davidson CL (1995) Influence of light intensity on polymerization shrinkage and integrity of restoration cavity interface *European Journal of Oral Science* **103(5)** 322-326.

Gallo JR, Comeaux R, Haines B, Xu X & Burgess JO (2001) Shear bond strength of four filled dentin bonding systems *Operative Dentistry* **26(1)** 44-47.

Goracci G, Mori G & Bazzucchi M (1995) Marginal seal and biocompatibility of fourth generation bonding agent *Dental Materials* **11(6)** 343-347.

- Goracci G, Mori G & De Martinis LC (1996) Curing light intensity and marginal leakage of resin composite restorations *Quintessence International* **27(5)** 355-362.
- Hansen EK & Asmussen E (1997) Visible light curing units: correlation between exit window and resin surface *Acta Odontologica Scandinavica* **55(3)** 162-166.
- Helvatjoglou-Antoniad M, Papadogianis Y, Koliniotou-Kubia E & Kubian S (1991) Surface hardness of light-cured and self-cured composite resins *Journal of Prosthetic Dentistry* **65(2)** 215-220.
- Kays BT, Sneed WD & Nuckles DB (1991) Microhardness of class II composite resin restorations with different matrices and light positions *Journal of Prosthetic Dentistry* **65(4)** 487-490.
- Kidd EAM (1976) Microleakage: a review *Journal of Dentistry* **4(5)** 199-206.
- Konstantinos F (1998) Microleakage reduction from newer esthetic restorative materials in permanent molars *The Journal of Clinic Pediatric Dentistry* **22(3)** 221-229.
- Leinfelder KF (1995) Posterior composite resin: the material and their clinical performance *Journal of American Dental Association* **126(5)** 663-676.
- Liberman R, Gorfil C & Ben-Amar A (1996) Reduction of microleakage in class II composite resin restoration using retentive pins *Journal of Oral Rehabilitation* **23(4)** 240-243.
- Lutz F, Krejci I & BarbaKow F (1992) Restoration quality in relation to wedge-mediated light channeling *Quintessence International* **23(11)** 763-767.

- Mandras RS, Retief DH & Russel CM (1991) The effects of thermal and occlusal stresses on the microleakage of the Scotchbond 2 dentinal bonding system *Dental Materials* **7(1)** 63-67.
- Mehl A, Hickel R & Kunzelmann KH (1997) Physical properties and gap formation of light-cured composites with and without 'soft-start-polymerization' *Journal of Dentistry* **25(3-4)** 321-330.
- Meiers JC, Kazemi R & Meier CD (2001) Microleakage of packable composite resins *Operative Dentistry* **26(2)** 121-126.
- Nakabayashi N & Saimi Y (1996) Bonding to intact dentine *Journal of Dental Research* **75(9)** 1706-1715.
- Opdam NJM, Roeters FJM, Feilzer AJ & Verdonchot EH (1998) Marginal integrity and post operative sensitivity in class II resin composite restoration in vivo *Journal of Dentistry* **26(7)** 555-562.
- Ota K, Kituchi S, Kopel HM, Thanos CE & Nakamura RM (1985) Effect of light exposure time on the depth of curing in various composite resin systems *Pediatric Dentistry* **7(1)** 19-22.
- Park SH, Krejci I & Lutz F (2002) Microhardness of resin composite polymerized by plasma arc or conventional visible light curing *Operative Dentistry* **27(1)** 30-37.
- Peutzfeldt A, Sahafi A & Asmussen E (2000) Characterization of resin composites polymerized with plasma arc curing units *Dental Materials* **16(5)** 330-336.

- Pimenta LAF (1999) Avaliação da microinfiltração em restaurações de classe II em compósito realizadas com duas técnicas diferentes de inserção. Piracicaba 94p. [Tese (Livre Docência) – FOP – UNICAMP].
- Pires JA, Cvitko E, Denehy GE & Swift Jr EJ (1993) Effects of curing tip distance on light intensity and composite resin microhardness *Quintessence International* **24(7)** 517-521.
- Rueggeberg FA, Caughman WF & Curtis Jr JW (1994) Effect of light intensity and exposure duration on cure of resin composite *Operative Dentistry* **19(1)** 26-32.
- Ruyter IE & Oysaed H (1982) Conversion in different depths of ultraviolet and visible light activated composite materials *Acta Odontologica Scandinavica* **40(3)** 179-192.
- Sahafi A, Peutzfeldt A & Asmussen E (2001) Soft-Start polymerization and marginal gap formation in vitro *American Journal of Dentistry* **14(3)** 145-147.
- Silikas N, Eliades G & Watts DC (2000) Light intensity effects on resin composite degree of conversion and shrinkage strain *Dental Materials* **16(4)** 292-296.
- Tjan AHL, Bergh BH & Lidner C (1992) Effect of various incremental techniques on the marginal adaptation of class II composite resin restorations *Journal of Prosthetic Dentistry* **67(1)** 62-66.
- Uno S & Asmussen E (1991) Marginal adaptation of a restorative resin polymerized at reduced rate *Scandinavian Journal Dental Research* **99(5)** 440-444.
- Unterbrink GL & Muessner R (1995) Influence of light intensity on two restorative systems *Journal of Dentistry* **23(3)** 183-189.

Yap AUJ, Ng SC & Siow KS (2001) Soft-Start polymerization: influence on effectiveness of cure and post-gel shrinkage *Operative Dentistry* **26(3)** 260-266.

Yap AUJ, Soh MS & Siow KS (2002) Post-gel shrinkage with pulse activation and soft-start polymerization *Operative Dentistry* **27(1)** 81-87.

Table 1. Results of microleakage evaluation.

Groups	Medium Ranks	
G5. Z250/Conventional	55.4737	a
G6. Z250/SS1	55.4737	a
G1. SureFil/Conventional	63.1316	ab
G7. Z250/SS2	70.0263	abc
G8. Z250/PAC	81.6579	abcd
G2. SureFil/SS1	87.6316	bcd
G3. SureFil/SS2	96.8947	cd
G4. SureFil/PAC	101.7105	d

Kruskal-Wallis test: Significant difference ($p < 0.05$)

Same letters were not statistically different.

Table 2. Means and standard deviations Knoop Hardness Number (KHN) for the different cure modes, resin composite and depth.

Resin Composite	Cure Mode	Depth					
		Bottom (100 μm)		Medium (2,500 μm)		Top (5,000 μm)	
		Mean	SD	Mean	SD	Mean	SD
SureFil	C	100.06	25.44	107.45	13.59	112.82	11.36
SureFil	SS1	103.69	13.46	112.30	8.66	109.04	11.12
SureFil	SS2	95.94	16.12	100.64	20.73	109.13	11.76
SureFil	PAC	95.20	20.76	100.43	21.0	120.20	10.33
Z250	C	99.15	15.08	100.73	16.21	100.67	13.06
Z250	SS1	94.23	22.42	108.75	26.46	109.20	18.85
Z250	SS2	96.44	15.03	104.04	7.89	105.97	12.11
Z250	PAC	97.65	16.46	99.80	19.25	105.80	13.82
Mean		97.80 C		104.27 B		109.1A	

Tukey's test ($p < 0.05$) indicates statistical difference for means followed by distinct letters.

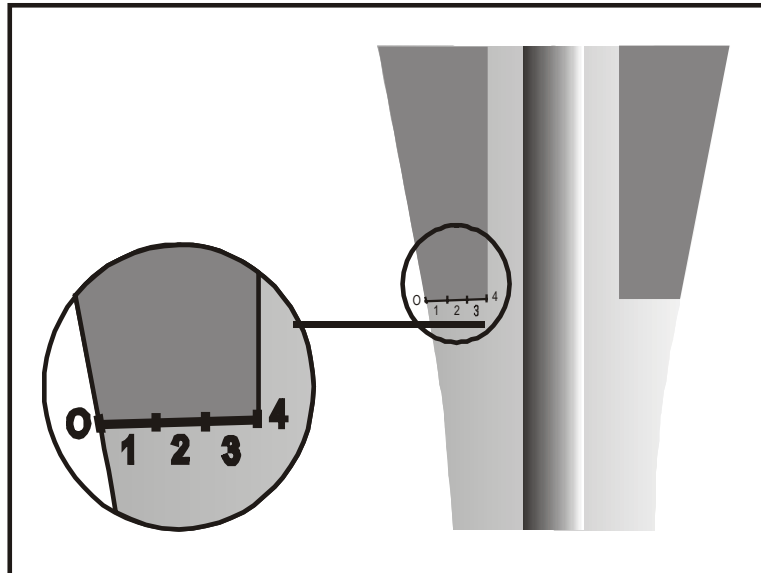

Figure 1: Scores used for microleakage evaluation.

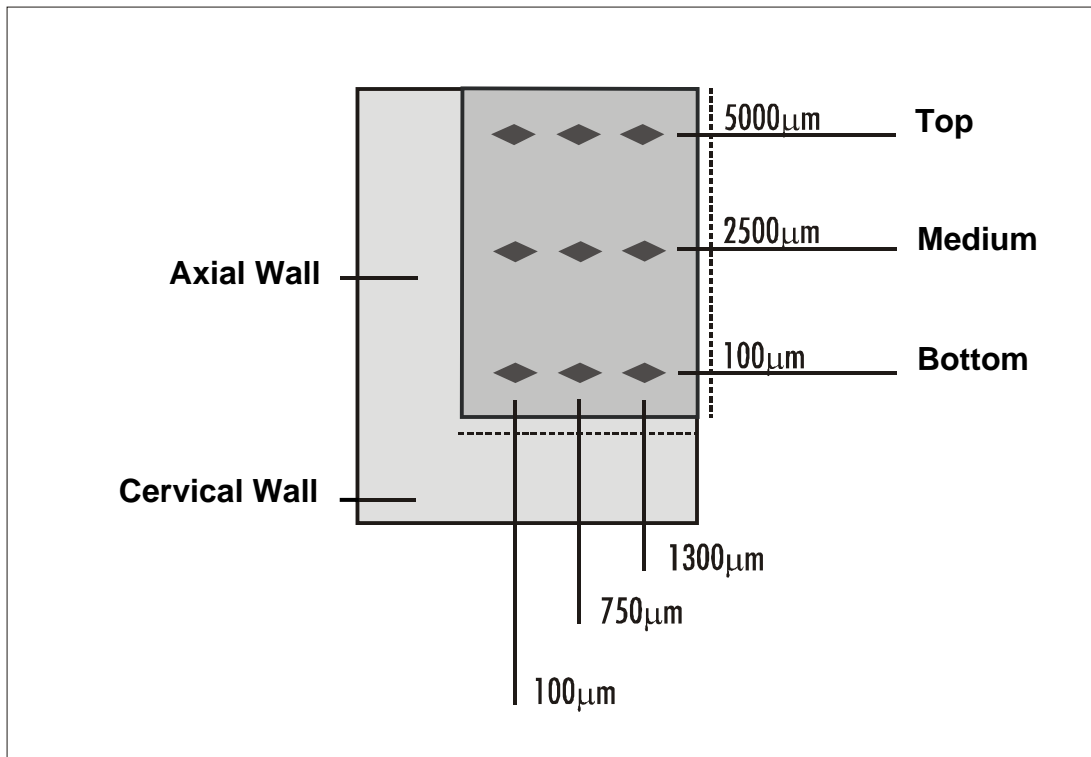

Figure 2: Localization of indentations for Knoop microhardness test.

3.4. Capítulo IV

***Microleakage evaluation of resin composite
restorations polymerized with different blue light-
emitting diode units (LEDs)***

Enviado para publicação na revista Quintessence International

***Microleakage evaluation of resin composite restorations
polymerized with different blue light-emitting diode units
(LEDs)***

Cristiane Mariote Amaral, DDS, MS¹; Larissa Maria Assad Cavalcante, DDS²;
Alessandra Rezende Peris, DDS³; Luiz André Freire Pimenta DDS, MS, PhD⁴;
Gláucia Maria Bovi Ambrosano DDS, MS⁵.

1 - Graduate Student, Department of Restorative Dentistry, School of Dentistry of Piracicaba, University of Campinas (UNICAMP), Piracicaba, Brazil.

2 - Clinical Practical, Department of Restorative Dentistry, School of Dentistry of Piracicaba, University of Campinas (UNICAMP), Piracicaba, Brazil.

3 - Graduate Student, Department of Restorative Dentistry, School of Dentistry of Piracicaba, University of Campinas (UNICAMP), Piracicaba, Brazil.

4 - Associate Professor, Department of Restorative Dentistry, School of Dentistry of Piracicaba, University of Campinas (UNICAMP), Piracicaba, Brazil.

5 - Assistant Professor, Department of Social Dentistry - Biostatistic, School of Dentistry of Piracicaba, University of Campinas (UNICAMP), Piracicaba, Brazil.

Correspondence:

Professor Luiz André Freire Pimenta

School of Dentistry of Piracicaba - UNICAMP - Restorative Dentistry

Av. Limeira, 901 – Areião, Caixa Postal 52, Piracicaba - SP, Brazil.

CEP 13414-018

Fax: 55-19-3412-5218.

Phone: 55-19-3412-5340.

e-mail: lpimenta@fop.unicamp.br

Abstract: Objective: The aim of this study was to evaluate the microleakage of class II resin composite restorations polymerized with light-emitting diodes units (LEDs), with different numbers of blue diodes. **Method and Materials:** One hundred sixty-eight class II cavities were prepared in bovine teeth. A one-bottle adhesive system (Single Bond/3M) was applied. The microhybrid or packable resin composite were inserted in three horizontal increments and cured for 40 seconds each, according to the follow groups (n=21): G1- Z250 (3M) + LED light curing unit with 19 LEDs (3M Espe); G2- Surefil (Dentispaly) + LED light curing unit with 19 LEDs; G3- Z250 + LED light curing unit with 7 LEDs (DMC); G4- Surefil + LED light curing unit with 7 LEDs; G5- Z250 + LED light curing unit with 6 LEDs (MM Optics); G6- Surefil + LED light curing unit with 6 LEDs; G7- Z250 + conventional halogen light curing unit (Demetrom-Kerr); G8- Surefil + conventional halogen light curing unit. After thermocycling, the samples were immersed in 2% methylene blue solution and then evaluated for microleakage. **Results:** The Kruskal-Wallis and non-parametric Multiple Comparison tests ($p < 0.05$) showed statistically significant differences among groups (median): G1: 1(d); G2: 4(a); G3: 1(cd); G4: 4(a); G5: 2(bc); G6: 4(a); G7: 1(cd); G8: 4(ab). **Conclusions:** The blue light-emitting diode units (LEDs) demonstrated similar results to the conventional halogen lamp unit and the microleakage of the packable resin composite was significantly more severe than the microhybrid resin composite.

Key words: blue light emitting diode, light curing units, polymerization, resin composite, microleakage, class II restorations.

Clinical relevance: The LEDs light curing units present inherent advantages and they appear to promise a good perspective for future clinical use.

Introduction

In recent years, the popularity of esthetic tooth-colored restorations has promoted a rapidly increasing use of resin composites.^{1,2} However, resin composites still present a number of limitations such as polymerization shrinkage,^{3,4} which has been associated with lack of marginal integrity, deflection of cusps, production of internal stress and postoperative sensitivity.^{2,4,5}

Many techniques have been studied to control the polymerization shrinkage, such as soft-start polymerization,^{6,7,8,9} the pulse delay^{9,10} and reduced rate polymerization,^{11,12} which employ halogen lamps. High-intensity curing lights are also commercially attractive to clinicians because the time spent polymerizing resin composite restorations can be reduced to up to 75%.¹³ Belonging to this category are the argon laser light curing units and plasma arc light units.¹³

Despite their popularity, halogen technology light curing units have several drawbacks.^{14,15} For example, halogen bulbs have a limited effective lifetime of approximately 100 hours, and the bulb, the reflector and the filter can degrade over time due to the high operating temperatures and the large quantity of heat that is produced during the operating cycles.^{14,15}

To overcome the problems inherent to halogen light curing units, solid-state light emitting diode (LED) technology has been proposed for curing light-activated dental materials.^{14,15,16}

LEDs have an expected lifetime of several thousand hours without significant degradation of light flux over time^{15,16,17} and, in addition, LEDs require no filters to produce blue light.¹⁷ The most frequently employed resin composites

have camphorquinone as a photoinitiator, which has an absorption peak of 467 nm that approximately coincides with the emission peak of the LEDs light curing units, at 465 nm. ^{1,14,16} The spectral purity of LEDs light curing units make the polymerization process of resin composite more efficient, ¹⁶ with the advantage to prevent the overheating. ^{16,18}

Several studies have reported that samples cured by LED units showed some inferior physical properties ^{1,14,15} and an inferior degree of conversion ¹⁸ when compared with halogen lamps. However, the LED units exceeded by far the minimum composite depth of cure according to ISO 4049 ^{14,15} and, when the halogen lamps compared had equal irradiance to LED light curing unit, the depth of cure is greater for samples cured by LED light curing unit. ¹⁷

Adequate polymerization is a crucial factor in obtaining optimal physical properties and clinical performance of resin composites. Problems associated with inadequate polymerization include inferior physical properties, solubility in the oral environment, and increased microleakage. ¹⁸ The aim of this study was to evaluate the marginal microleakage of class II resin composites restorations polymerized with blue light-emitting diode units (LEDs), with different numbers of blue diodes, in comparison with the conventional halogen lamp.

Method and Materials

Eighty-four extracted bovine incisor teeth were initially stored in a saline solution containing 0.5% sodium azide, after which the debris was removed from the teeth. The crowns of the bovine teeth were cut off 5 mm above the cemento-enamel junction (CEJ), with a double-faced diamond disk (KG Sorensen, Brazil).

“Slot” type Class II cavities at the mesial and lingual surfaces were prepared with carbide burs (Jet Brand, Canada) in a high-speed water-cooled hand piece. Burs were replaced after every 8 preparations to maintain uniformity. Butt-joint cavities had the following dimensions: 1.5 mm axial deep by 3 mm bucco-lingual wide and the gingival margin was located 1mm apical to the CEJ.

In all groups, enamel and dentin etching with 35% phosphoric acid (3M Dental, USA) was performed for 15 seconds. The Single Bond (3M Dental, USA) adhesive system was applied following manufacturer’s instructions. The Z250 microhybrid resin composite (3M Dental, USA) and Surefil packable resin composite (Dentisply Caulk, USA) were inserted in three horizontal increments and each increment was cured for 40 seconds, according to the follow groups (n=21):

G1: microhybrid resin composite cured with LEDs light curing unit (Elipar™ FreeLight, 3M ESPE, USA), composed of nineteen LEDs;

G2: packable resin composite cured with LEDs light curing unit (Elipar™ FreeLight, 3M ESPE, USA), composed of nineteen LEDs;

G3: microhybrid resin composite cured with LEDs light curing unit (Ultrablue III, DMC, Brazil), composed of seven LEDs;

G4: packable resin composite cured with LEDs light curing unit (Ultrablue III, DMC, Brazil), composed of seven LEDs;

G5: microhybrid resin composite cured with LEDs light curing unit (LEC-470 I, MM Optics, Brazil), composed of six LEDs;

G6: packable resin composite cured with LEDs light curing unit (LEC-470 I, MM Optics, Brazil), composed of six LEDs;

G7 (control 1): microhybrid resin composite cured with conventional halogen light curing unit (Optilux 501, Demetrom-Kerr, USA);

G8 (control 2): packable resin composite cured with conventional halogen light curing unit (Optilux 501, Demetrom-Kerr, USA).

The descriptions and the intensity of the light curing units are summarized in table 1.

Following the restorative procedure, the teeth were stored in a humid environment at 37°C for 48 hours. After this time, all restorations were finished with Sof-Lex (3M Dental, USA) medium, fine and ultrafine finishing disks. All specimens were then thermocycled in a thermal cycling machine (MCT2 AMM, Instrumental, Brazil) for 1,000 cycles at $5 \pm 2^\circ\text{C}$ and $55 \pm 2^\circ\text{C}$ with a dwell time of 60 seconds in distilled water with a 5-second transfer time. Next, the apices and coronal surfaces were sealed with epoxy resin (Araldite, Brascola Ltda, Brazil) and the teeth were coated with two applications of fingernail polish up to 1 mm from the gingival margins. All teeth were immersed in a freshly prepared aqueous solution of 2% methylene blue (pH 7.0) for 4 hours at 37°C and then washed in

water. Finally, each tooth was sectioned vertically through the center of the restoration with a diamond disk at low-speed.

Microleakage at the gingival margin was evaluated by two observers with an optical stereomicroscope (Meiji 2000, Meiji, China) at 60x magnification and scored using the following criteria:

0 - No dye penetration

1 - Dye penetration that extended for less than or up to 1/3 of preparation depth

2 - Dye penetration greater than 1/3 or up to 2/3 of preparation depth

3 - Dye penetration greater than 2/3 of preparation depth

4 - Dye penetration reaching or passing the axial wall.

The scores evaluation was submitted to the Kruskal-Wallis and non-parametric Multiple Comparison tests at 5% level of significance ($\alpha=0.05$) in order to evaluate the differences among the experimental groups.

Results

The distribution of microleakage scores for each group is presented in table 2. The microleakage of packable resin composite was significantly more severe than the microhybrid resin composite under any light curing unit. For both resin composites, blue light-emitting diode units (LEDs) presented similar compartment to conventional halogen lamp unit (table 3). For microhybrid resin composite, the LEDs light curing unit composed of six LEDs presented significantly more microleakage than the LEDs light curing unit composed of nineteen LEDs.

Discussion

The results of this study showed good comportment for LEDs light curing units. The LEDs light curing unit with nineteen LEDs presented the least amount of microleakage for the microhybrid resin composite, but it was statistically different from the group cured with six LEDs only.

Although the light intensity of the LEDs light curing units was considerably low, it probably obtained adequate polymerization, since the microleakage did not increase for these groups. This is possible because the LED emission spectrum fits the maximum absorption of camphorquinone,¹⁹ making the polymerization process of resin composite more efficient.^{14,15,16,19} In comparison, the emission spectrum of a halogen light is considerably broader, exhibiting larger irradiance in all other regions, although the wavelength range is already adjusted by filters.^{14,15,19}

Some other studies demonstrated a decrease of physical and mechanical properties when the resin composite was cured with LEDs light curing units. Stahl *et al.*¹⁴ showed that mean flexural strength and mean flexural modulus are significantly greater for specimens polymerized with the halogen light curing unit than for those specimens polymerized with LEDs light curing unit with seventeen LEDs, although both fulfill the ISO 4049 requirement in terms of flexural strength.

Jandt *et al.*¹⁵ also showed that the conventional halogen light curing unit cured composites significantly deeper than the LEDs light curing unit. However, both units cured the composite deeper than required by both ISO 4049

and the manufacturer. For compressive strengths, there were no significant differences between samples produced with LEDs or conventional light curing units.¹⁵

When using LEDs light curing units (with two, three, four, five or six LEDs), Kurachi *et al.*¹ observed inferior hardness for these samples when compared with the halogen lamp. The authors suggested that longer exposure times or a thinner resin layer are required to achieve reasonable hardness values due to their reduced irradiance. Medeiros²⁰ also suggested that longer exposure time (sixty seconds) is necessary to polymerize increments of 2 mm.

The degree of conversion for four hybrid resin composites was higher for all materials polymerized by halogen curing units.¹⁸ Great differences of curing intensity were also observed in which the low curing energy of blue LEDs enables a slower polymerization reaction in composite material.¹⁸

This slow polymerization reaction influences flow characteristics and may be useful in moderating the development of shrinkage stress and improving marginal sealing.¹¹ Therefore, in this study, less microleakage could be caused by decrease of shrinkage stress for samples cured by LEDs light curing units.

The slower polymerization reaction of LEDs light curing units also causes less temperature increases than conventional halogen lamp.^{18,20} Furthermore, the LEDs light curing units have the advantage of being small and wireless, improving handling properties,¹⁹ as the units with nineteen and seven LEDs used in this study.

Statistical difference was observed between hybrid and packable resin composites for all light curing units. Along with the polymerization process, shrinkage stress build-up occurs after the material acquires stiffness.²¹ The amount of contraction stress has been determined to be dependent on the extent of the reaction, the stiffness of composite and its ability to flow.^{4,21,22} Less rigid materials were observed to be better capable of reducing the contraction stresses than rigid materials and the packable resin composite is more rigid than microhybrid resin composite.⁴

The highly filled small-sized interlocking filler particles of Surefil packable resin composite may, to some extent, obstruct the composite to change shape during polymerization, resulting in an overall higher stress build-up than the hybrid composite.²¹ This technology can also decrease the capacity of flow,²³ and the lower the capacity of flow, the greater will be the shrinkage stress, which can be decisive for the success of the bonding procedure.²⁴ Chen *et al.* observed that packable resin composites exhibited significantly higher maximum contraction stress and a higher rate of contraction force than a conventional hybrid resin composite.²¹ In this study, the hybrid resin composite can also have benefited the bond with the cavity walls.

Due to their inherent advantages and the positive results of this study, LEDs light curing units appear to promise a good perspective for future clinical use.

Conclusions

This “*in vitro*” study, in bovine teeth, allowed us to conclude:

1. The LEDs light curing units present similar results in controlling of the microleakage when compared to conventional halogen lamps for both resin composites used;

2. For microhybrid resin composite, the LEDs light curing unit LEC-470 I composed of six LEDs presented significantly more microleakage than the LEDs light curing unit Elipar™ FreeLight, composed of nineteen LEDs;

3. The microleakage of Surefil packable resin composite was significantly more severe than the Z250 microhybrid resin composite for all light curing units.

Acknowledgments

The authors would like to thank the manufacturers 3M ESPE, DMC Equipments and MM Optics in donating the light curing units.

Continuing Education

1. Answer T (true) or F (false):

(T) A. Halogen technology light curing units have several drawbacks.

(T) B. The halogen bulbs have a limited effective lifetime.

(T) C. Large quantity of heat is produced during operating cycles of halogen light curing.

(F) D. The LED light curing units require filters to produce blue light.

2. The LEDs light curing units have the following characteristics, except:

A. They have the advantage to prevent the overheating.

B. They have an expected lifetime of few hours.

C. The absorption peak of camphorquinone coincides with emission peak of LEDs.

D. The spectral purity of LEDs light curing units make the polymerization process of resin composite more efficient.

Correct answer: B

3. Indicate the correct answer:

A. The conventional halogen lamp unit presented less microleakage than LEDs light curing units.

B. The LEDs light curing unit with seven LEDs presented the least amount of microleakage.

C. LEDs light curing units presented similar compartment to conventional halogen lamp unit.

D. The LEDs light curing units presented significant more microleakage than conventional halogen lamp unit.

Correct answer: C

4. Answer T (true) or F (false):

(T) For microhybrid resin composite, the LEDs light curing unit composed of nineteen LEDs presented significantly less microleakage than the LEDs light curing unit composed of six LEDs.

(F) The light intensity of LEDs light curing units was considerably high.

(T) The microleakage of packable resin composite was significantly more severe than the microhybrid resin composite under any light curing unit.

(T) The LEDs light curing units have the advantage can be small and wireless, improving handling properties.

References

1. Kurachi C, Tuboy AM, Magalhães DV, Bagnato VS. Hardness evaluation of a dental composite polymerized with experimental LED-based devices. *Dent Mat* 2001; 17: 309-315.
2. Applequist EA, Meiers JC. Effect of bulk insertion, prepolymerized resin composite balls, and beta-quartz inserts on microleakage of class V resin composite restorations. *Quintessence Int* 1996; 27: 253-258.
3. Tjan AHL, Bergh BH, Lidner C. Effect of various incremental techniques on the marginal adaptation of class II composite resin restorations. *J Prosthet Dent* 1992; 67: 62-66.
4. Davidson CL, Feilzer AJ. Polymerization shrinkage and polymerization shrinkage stress in polymer-based restoratives. *J Dent* 1997; 25: 435-440.
5. Eick JD, Welch FH. Polymerization shrinkage of posterior composite resins and its possible influence on postoperative sensitivity. *Quintessence Int* 1986; 17: 103-111.
6. Mehl A, Hickel R, Kunzelmann KH. Physical properties and gap formation of light-cured composites with and without 'softstart-polymerization'. *J Dent* 1997; 25: 321-330.
7. Yap AUJ, Ng SC, Siow KS. Soft-start polymerization: influence on effectiveness of cure and post-gel shrinkage. *Oper Dent* 2001; 26: 260-266.
8. Sahafi A, Peutzfeldt A, Asmussen E. Soft-start polymerization and marginal

- gap formation *in vitro*. Am J Dent 2001; 14: 145-147.
9. Yap AUJ, Soh MS, Siow KS. Effectiveness of composite cure with pulse activation and soft start polymerization. Oper Dent 2002; 27: 44-49.
 10. Cardoso PEC, Burmann PA, Soares LF, Melo T, Casagrande L. Microinfiltração em restaurações oclusais de resina composta fotopolimerizadas pela técnica do pulso atrasado. Pesq Odontol Bras 2000; 14: 66 (Abstract 47).
 11. Feilzer AJ, Dooren LH, de Gee AJ, Davidson CL. Influence of light intensity on polymerization shrinkage and integrity of restoration-cavity interface. Eur J Oral Sci 1995; 103: 322-326.
 12. Unterbrink GL, Muessner R. Influence of light intensity on two restorative systems. J Dent 1995; 23: 183-189.
 13. Brackett WW, Haisch LD, Covey DA. Effect of plasma arc curing on the microleakage of class V resin-based composite restorations. Am J Dent 2000; 13: 121-122.
 14. Stahl F, Ashworth SH, Jandt KD, Mills RW. Light-emitting diode (LED) polymerization of dental composites: flexural properties and polymerization potential. Biomaterials 2000; 21: 1379-1385.
 15. Jandt KD, Mills RW, Blackwell GB, Ashworth SH. Depth of cure and compressive strength of dental composites cured with blue light emitting diodes (LEDs). Dent Mat 2000; 16: 41-47.
 16. Andrade MF, Rastelli ANS, Saadi RS, Saad JRC. Avaliação da capacidade de

- polimerização de um novo dispositivo 'a base de LED à bateria. *J Am Dent Assoc - Brasil* 2001; 4: 373-377.
17. Mills RW, Jandt KD, Ashworth SH. Dental composite depth of cure with halogen and blue light diode technology. *Br Dent J* 1999; 186: 388-391.
 18. Knežević A, Tarle Z, Meniga A, Šutalo J, Pichler G. Degree of conversion and temperature rise during polymerization of composite resin samples with blue diodes. *J Oral Rehabil* 2001; 28: 586-591.
 19. Althoff O, Hartung M. Advances in light curing. *Am J Dent* 2000; 13: 77-81.
 20. Medeiros IS. Dispositivos LED para polimerização de resinas compostas dentais: comparação com outras fontes de luz. São Carlos, 2001. 112p. [Tese (Mestrado) Universidade de São Paulo].
 21. Chen HY, Manhart J, Hickel R, Kunzelmann KH. Polymerization contraction stress in light-cured packable composite resins. *Dent Mat* 2001; 17: 253-259.
 22. Feilzer AJ, de Gee AJ, Davidson CL. Quantitative determination of stress reduction by flow in composite restorations. *Dent Mater* 1990; 6: 167-171.
 23. Meiers JC, Kazemi R, Meier CD. Microleakage of packable composite resins. *Oper Dent* 2001; 26: 121-126.
 24. Carvalho RM, Pereira JC, Yoshiyama M, Pashley DJ. A review of polymerization contraction: the influence of stress development versus stress relief. *Oper Dent* 1996; 21: 17-24.

Table 1: Light curing units used in this study and their intensities.

Light Source	Light curing unit/manufacturer	Light intensity
19 LEDs	Elipar™ FreeLight, 3M ESPE, USA	280 mW/cm ²
7 LEDs	Ultrablue III, DMC, Brazil	140 mW/cm ²
6 LEDs	LEC-470 I, MM Optics, Brazil	100 mW/cm ²
Halogen Lamp	Optilux 501, Demetrom-Kerr, USA	850 mW/cm ²

Table 2: Distribution of microleakage scores for each group.

Resin composite/						
Groups	Light Curing Unit	Distribution of Scores				
		0	1	2	3	4
G1	Microhybrid / 19 LEDs	2	16	1	1	0
G2	Packable/ 19 LEDs	0	4	1	2	12
G3	Microhybrid / 7 LEDs	2	10	1	1	4
G4	Packable / 7 LEDs	0	2	2	3	13
G5	Microhybrid / 6 LEDs	2	6	2	2	5
G6	Packable / 6 LEDs	0	2	3	1	13
G7	Microhybrid / Conventional	1	11	4	3	2
G8	Packable / Conventional	2	3	2	1	12

Table 3: Results (Median and Rank Sum) of microleakage for each group.

Resin composite/ Light Curing Unit	Median	Rank Sum	
Microhybrid / 19 LEDs	1	37.60	d
Microhybrid / 7 LEDs	1	57.17	cd
Microhybrid / 6 LEDs	2	68.53	bc
Microhybrid / Conventional	1	57.14	cd
Packable / 19 LEDs	4	98.87	a
Packable / 7 LEDs	4	104.38	a
Packable / 6 LEDs	4	104.53	a
Packable / Conventional	4	91.85	ab

Means followed by different letters were statistically different in the Kruskal-Wallis test and non-parametric Multiple Comparison test ($p < 0.05$).

3.5. Capítulo V

***Influence of different polymerization techniques on
adhesion of resin composite restorations***

Enviado para publicação na revista Operative Dentistry

***Influence of different polymerization techniques on
adhesion of resin composite restorations***

Cristiane Mariote Amaral, DDS, MS¹; Alessandra Rezende Peris, DDS²; Glaucia Maria Bovi Ambrosano DDS, MS, PhD³; Luiz André Freire Pimenta DDS, MS, PhD⁴.

Short Title: Influence of polymerization techniques on adhesion

1 - Graduate Student, Department of Restorative Dentistry, School of Dentistry of Piracicaba, University of Campinas (UNICAMP), Piracicaba, Brazil.

2 - Graduate Student, Department of Restorative Dentistry, School of Dentistry of Piracicaba, University of Campinas (UNICAMP), Piracicaba, Brazil.

3 - Assistant Professor, Department of Social Dentistry - Biostatistic, School of Dentistry of Piracicaba, University of Campinas (UNICAMP), Piracicaba, Brazil.

4 - Associate Professor, Department of Restorative Dentistry, School of Dentistry of Piracicaba, University of Campinas (UNICAMP), Piracicaba, Brazil.

Correspondence:

Professor Luiz André Freire Pimenta

School of Dentistry of Piracicaba - UNICAMP - Restorative Dentistry

Av. Limeira, 901 – Areião, Caixa Postal 52, Piracicaba - SP, Brazil.

CEP 13414-018

Fax: 55-19-3412-5218.

Phone: 55-19-3412-5340.

e-mail: lpimenta@fop.unicamp.br

Clinical Relevance: The polymerization techniques soft-start, LED light curing, and plasma arc curing did not affect the adhesion of resin composites restorations when compared with conventional polymerization. The packable resin composite restorations presented lower bond strength than microhybrid resin composite restorations.

Summary: The aim of this study was to evaluate the influence of soft-start, LED unit, plasma arc curing (PAC), and conventional polymerization techniques on microtensile bond strength of microhybrid (Z250) and packable (Solitaire 2) resin composites restorations. One hundred and four class V cavities were treated with the dentin bonding agent Single Bond according to the manufacturer's instructions. The cavities were randomly assigned to 8 groups (n=13): one of the resin composites was inserted in bulk increment and polymerized with one of techniques: Soft-start - 10 s at 160 mW/cm² + 30 s at 560 mW/cm² with halogen lamp; LED light curing - 40 s at 120 mW/cm²; Plasma Arc curing - 6 s at 1,760 mW/cm² for packable resin composite and 3 s at 1,760 mW/cm² for microhybrid resin composite; Conventional light curing - 40 s at 560 mW/cm². After the restorative procedures, the samples were thermocycled (1,000 cycles at 5°C and 55°C), and sectioned in small sticks with a rectangular cross-sectional area of approximately 1 mm², using a diamond saw machine. The sticks were fixed to matrices, placed in a testing apparatus and the microtensile test was performed in a universal testing machine at a crosshead speed of 0.5 mm/min. The bond strength (MPa) of each stick was calculated and the mean of specimen was submitted to split-plot ANOVA and Tukey tests ($\alpha=0.05$). The polymerization techniques did not affect the adhesion of resin composite restorations. However, the packable resin composite restorations presented lower bond strength than microhybrid resin composite restorations, for all polymerization techniques.

Introduction

Light curing resin composites in combination with dentin bonding systems are commonly used in restorative dentistry (Sahafi, Peutzfeldt & Asmussen, 2001). However, polymerization shrinkage is still a major problem in light curing restorations (Friedl & others, 2000).

The polymerization shrinkage of resin composite can enhance contraction forces that may disrupt the bond to cavity walls (Carvalho & others, 1996; Davidson & Feilzer, 1997). This competition between the mechanical stress in polymerizing resin composites and the adhesion to the walls of cavity is one of the main causes of marginal failure and subsequent microleakage (Davidson, de Gee & Feilzer, 1984). The amount of stress generated during polymerization of resin composites is related to the restriction of polymerization shrinkage in a cavity (Feilzer, de Gee & Davidson, 1987; Carvalho & others, 1996). When the resin composite is attached to more than two dentin walls, flow capacity is severely limited, and the value of shrinkage stress can exceed the bond strength (Davidson & others, 1984).

One of the most studied approaches to control the shrinkage stresses consists of initially reduced conversion of the resin composite, controlling the flow capacity during curing (Mehl, Hickel & Kunzelmann, 1997). This might be done with the soft-start polymerization that involves a prepolymerization at low light intensity followed by final cure at high intensity (Uno & Asmussen, 1991; Mehl & others, 1997).

Also, new light curing units have been introduced. The plasma arc curing (PAC) units present high light intensity and may reduce up to 75% the time spent polymerizing the resin composite (Brackett, Haisch & Covey, 2000).

Solid-state light emitting diode (LED) technology has also been proposed for curing light-activated dental materials. LED have an expected lifetime of several thousand hours (Mills, Jandt & Ashworth, 1999; Jandt & others, 2000; Andrade & others, 2001) and require no filters to produce blue light (Mills & others, 1999). Furthermore, the spectral purity of LED light curing units make the polymerization process of resin composite more efficient (Andrade & others, 2001).

In order to evaluate if these polymerization techniques may reduce the shrinkage stress and preserve the adhesion, the bond strength must be evaluated in cavities, where flow capacity of resin composites is limited. This is possible with the microtensile bond strength test, which allows the measuring of bond strength in a small region and in cavities (Shono & others, 1997).

Thus, the aim of this study was to evaluate the influence of soft-start, LED unit, plasma arc curing (PAC), and conventional polymerization techniques on microtensile bond strength of microhybrid and packable resin composite restorations.

Methods and Materials

One hundred and four extracted bovine incisor teeth stored in a 1% thymol solution were used in this study. The teeth were rinsed in running water, and any debris was removed. Standardized box shaped buccal class V cavities with

parallel walls were prepared with diamond burs in a high-speed water-cooled hand piece mounted in a drilling apparatus. The cavity dimensions (Fig. 1A) were: 4 mm in the mesiodistal and occlusocervical direction and the depth of the box was 1.6 mm (in dentin). The teeth were randomly assigned to 8 groups of 13 teeth each (Table 1).

The cavities were treated with the dentin bonding agent Single Bond (3M Dental Products, St Paul, MN 55144-1000, USA) according to the manufacturer's instructions. Dentin bonding agent was polymerized with the same technique used for resin composite polymerization. One microhybrid resin composite (Z250, 3M Dental Products, St Paul, MN 55144-1000, USA) or one packable resin composite (Solitaire 2, Heraeus Kulzer Inc, South Bend, IN 46614, USA) was inserted in bulk increment and polymerized with one of techniques: Soft-start (VIP, Bisco Inc, Schaumburg, IL 60193, USA) - 10 s at 160 mW/cm² + 30 s at 560 mW/cm² with halogen lamp; LED light curing (Ultrablue III, DMC Equipamentos, São Carlos, SP 13562-030, Brazil) - 40 s at 120 mW/cm²; Plasma Arc curing (DMD Corp, Westlake Village, CA 91362, USA) - 6 s at 1,760 mW/cm² for packable resin composite and 3 s at 1,760 mW/cm² for microhybrid resin composite; Conventional light curing (VIP, Bisco Inc, Schaumburg, IL 60193, USA) - 40 s at 560 mW/cm².

Following the restorative procedures, all teeth were thermocycled in a thermal cycling machine (MSCT-3Plus, Marcelo Nucci Automação, São Carlos, SP 13560-000, Brazil) for 1,000 cycles at 5°C and 55°C, with dwell time of 60 s in distilled water with a 5 s transfer time.

The teeth were sectioned using a double-faced diamond disk (KG Sorensen, Barueri, SP 06465-130, Brazil) to separate the root from the coronal portion (Fig. 1B). The coronal portion of teeth were sectioned in small sticks (Fig. 1C) with a rectangular cross-sectional area of approximately 1 mm², using a diamond saw machine (Isomet 1000, Buehler Ltd., Lake Bluff, IL 60044, USA). Just the four sticks of central area of each restoration were used for microtensile test (Fig. 1D).

The bonded surface area was calculated before testing by measuring the width and thickness of each stick, which were fixed to matrices with cyanoacrylate adhesive, and placed in a testing apparatus (Fig. 1E). The microtensile test was performed in a universal testing machine (EMIC Ltda, São José dos Pinhais, PR 83020-250, Brazil) at a crosshead speed of 0.5 mm/min. After failure of the adhesive, the bond strength (MPa) of each stick was calculated.

Mean bond strength for the four sticks of each tooth was calculated and submitted to split-plot ANOVA and Tukey tests ($\alpha=0.05$) to compare the groups.

Results

The results are presented in Table 2. There was no significant interaction between the factors resin composites vs polymerization techniques ($p=0.4768$). There was no significant difference in bond strength among soft-start, LED light curing, plasma arc curing, and conventional polymerization techniques ($p=0.5590$). The bond strength of the packable resin composite restorations was

significantly lower ($p < 0.05$) than the microhybrid resin composite restorations, for all polymerization techniques (Fig. 2).

Discussion

In general, in this study, the shrinkage stress did not exceed the bond strength of resin composite restorations, for all polymerization techniques.

However, in some sticks the bonding to dentin was disrupted before being positioned in the universal machine for microtensile test. In these cases, the bond strength of these sticks was recorded as zero, and this value was considered to calculate the mean of bond strength of the specimen. Shono & others (1999) reported that it is common that from four to six serial sections give widely different bond strengths. The calculation of means and standard deviation for the four sticks yielded an average bond strength value, and the size of standard deviation provided an indication of the consistency of bond strength (Shono & others, 1999). It is not clear whether the lack of consistency is due to specimen preparation, material properties, heterogeneity of the bonding substrate, or technique sensitivity (Shono & others, 1999).

All polymerization techniques presented similar values of microtensile bond strength. Thus, no polymerization technique probably caused shrinkage stress lower than conventional polymerization in order to contribute to a greater bond strength.

The soft-start polymerization presents conversion of the resin composite initially reduced that might increase the flow capacity during curing (Mehl &

others, 1997). Uno & Asmussen (1991) and Mehl & others (1997) observed some decrease of gap formation with soft-start polymerization. However, the results of other studies showed that the soft-start polymerization did not reduce the gap formation (Friedl & others, 2000; Sahafi & others, 2001) and the microleakage (Alonso & others, 2000; Friedl & others, 2000) in resin composite restorations. Mehl & others (1997) found improvement in marginal adaptation with soft-start polymerization, though in the microleakage evaluation the authors have not also observed significant difference between conventional or soft-start polymerization.

Other studies also observed no significant reduction in polymerization shrinkage with the soft-start polymerization (Unterbrink & Muessner, 1995; Koran & Kurschner, 1998; Silikas, Eliades & Watts, 2000; Yap, Ng & Siow, 2001; Yap, Soh & Siow, 2002). Regardless of the curing mode, the composite continued to shrink after removing the light source. This can be attributed to the post-curing of composite resins (Yap & others, 2002). Polymerization is approximately 75% complete at 10 minutes after light exposure and curing continues for a period of at least 24 hours (O'Brien, 1997). Soft-start polymerization light curing units frequently use a final cure of 500 mW/cm² or greater. The beneficial effect of the initial low intensity cure may therefore be annulled by the high intensity final cure (Yap & others, 2002). Silikas & others (2000) observed that shrinkage strain values of conventional and soft-start polymerization were not significantly different after 30 minutes. However, reduced light intensity (200 mW/cm²) for 10 and 40 seconds reduced shrinkage strain levels and degree of conversion (Silikas & others, 2000).

Koran & Kurschner (1998) observed that during the beginning of curing process, less shrinkage occurred in the specimens receiving the lower intensity (of soft-start polymerization) light than in that irradiated at higher intensity. Nevertheless, the overall results indicated that total final shrinkage of soft-start and conventional polymerization was not statistically different, and the total shrinkage is essentially independent on the light intensities (Koran & Kurschner, 1998). These authors also evaluated the adhesion to pretreated metal surfaces by push-out test. The results showed that adhesion of soft-start polymerization - 10 s at 150 mW/cm² + 30 s at 700 mW/cm² - was greater than conventional high intensities (40 s at 500 mW/cm² and 40 s at 700 mW/cm²). However, the adhesion of soft-start polymerization - 10 s at 150 mW/cm² + 30 s at 500 mW/cm² - did not differ from adhesion of conventional polymerization - 40 s at 500 mW/cm² (Koran & Kurschner, 1998).

In regards to LED light curing, its adhesion values were similar to all other polymerization techniques. LED light curing units present some advantages when compared with conventional halogen lamp, as expected lifetime of several thousand hours, require no filters to produce blue light and the emission peak that coincides with the absorption peak of camphorquinone, main photoinitiator present in resin composites (Mills & others, 1999; Jandt & others, 2000; Andrade & others, 2001). Furthermore, LED light curing units have an additional advantage to prevent the overheating (Andrade & others, 2001; Knezevic & others, 2001). Studies of shrinkage stress, marginal sealing, and adhesion of resin composite restorations polymerized with LED light curing were not still developed.

However, previous studies demonstrated a decrease of flexural strength (Stahl & others, 2000), flexural modulus (Stahl & others, 2000), depth of cure (Jandt & others, 2000), hardness (Kurachi & others, 2001), and degree of conversion (Knezevic & others, 2001) of the resin composites cured with LED light curing units when compared with conventional halogen light curing unit. However, flexural strength and depth of cure fulfill the ISO 4049 requirement (Jandt & others, 2000; Stahl & others, 2000). Longer exposure times (60 seconds) or a thinner resin layer were recommended to achieve reasonable hardness values due to the reduced irradiance of LED light curing units (Kurachi & others, 2001; Medeiros, 2001).

In regards to PAC, this polymerization technique did not also differ from other polymerization techniques on adhesion test. Park, Krejci & Lutz (2002) showed that the polymerization with PAC may cause less polymerization shrinkage than conventional polymerization (halogen lamp).

When the degree of conversion is less than the maximum, it will tend to reduce the shrinkage, and the PAC technique presents relatively small degree of conversion (Peutzfeldt, Sahafi & Asmussen, 2000). Thus, with the PAC, it may be argued that the rapid cure is compensated by the low degree of conversion resulting in gaps similar to conventional polymerization (Peutzfeldt & others, 2000).

Peutzfeldt & others (2000) evaluated the gap formation of restorations cured by two PAC units and a conventional halogen lamp. They observed that the light curing units showed similar gap formation for all adhesive/resin composite combinations, except in one combination adhesive/resin that the Apollo 95E (PAC)

showed less gap formation than the halogen lamp (Peutzfeldt & others, 2000). Hasegawa & others (2001) also observed no significant difference between PAC and conventional halogen lamp in gap formation.

Although in this study the polymerization techniques did not affect the adhesion, the resin composites (microhybrid or packable) did. As observed in other studies, the restorative material might be more critical than the polymerization technique (Alonso & others, 2000; Burmman & others, 2000). Furthermore, some restorative materials can be more dependent on light intensity than others (Unterbrink & Muessner, 1995).

The magnitude of contraction stress is dependent not only on the cavity configuration factor (C-factor), but also on the nature of the shrinkage material, notably the viscous-elastic properties. The amount of contraction stress has been determined to be dependent on the extent of the reaction, the stiffness of composite and its ability to flow (Davidson & Feilzer, 1997; Chen & others, 2001; Feilzer, De Gee & Davidson, 1990). Less rigid materials were observed to be more capable of reducing the contraction stresses than rigid materials (Davidson & Feilzer, 1997). As the packable resin composite is more rigid than microhybrid composite resin, the shrinkage stress produced during curing of packable resin composite might have been greater, affecting the adhesion. Chen & others (2001) also observed that packable composite resins (Alert, Surefil, Solitaire, Solitaire 2 and Definite) exhibited significantly higher maximum contraction stress and a higher rate of contraction force than a conventional hybrid composite resin (Tetric Ceram).

The filler size is another factor that can affect polymerization shrinkage (Li & others, 1985). It was observed a trend that the larger the filler particle size, the greater the mean shrinkage percentage (Aw & Nicholls, 2001). A weak positive correlation exists between filler size and shrinkage, meaning that composites with smaller filler particles may undergo less shrinkage (Aw & Nicholls, 2001). The Solitaire 2 packable resin composite contain larger filler particle (0.7 to 20 μm) than Z250 microhybrid resin composite (0.01 to 3.5 μm). The filler particle size of Solitaire 2 may have contributed to greater polymerization shrinkage, affecting the adhesion of the restorations.

Furthermore, smaller filler particles result in smaller interparticle distance and smaller masses of resin matrix in between the filler particles (Aw & Nicholls, 2001). Smaller continuous mass of composite can result in less bonds and shorter chain formations occurring, which results in decreased shrinkage (Aw & Nicholls, 2001). Also, larger filler particles would allow greater light transmission and penetration through the resin (Li & others, 1985), and hence, more polymerization and shrinkage (Aw & Nicholls, 2001).

In this study, the adhesion of resin composite restorations cured with different polymerization techniques did not differ from conventional polymerization technique with halogen lamp. Although the plasma arc curing may reduce the time of polymerization, this light curing unit has a high cost when compared with conventional light curing unit. On the other hand, further research is necessary to improve the performance of the LED light curing units in regards to

mechanical and physical properties of resin composite, because this technology is less expensive than conventional light curing units and very promising.

Conclusion

The results of this *in vitro* study allow us to make the following conclusions:

1. The polymerization techniques soft-start, LED light curing, and plasma arc curing did not affect the adhesion of resin composites restorations, when compared with conventional polymerization (halogen lamp);

2. The Solitaire 2 packable resin composite restorations presented lower bond strength than Z250 microhybrid resin composite restorations, for all polymerization techniques.

Acknowledgements

The authors gratefully acknowledge the support from Fundação de Amparo à Pesquisa do Estado de São Paulo (FAPESP - Grant 00/13681-6)

References

- Alonso RCB, Sinhoreti MAC, Consani S & Correr-Sobrinho L (2000) Efeito do método de polimerização sobre a infiltração marginal em restaurações com compósitos odontológicos *Pesquisa Odontológica Brasileira* **14**: 55 (Abstr I353).
- Andrade MF, Rastelli ANS, Saadi RS & Saadi JR (2001) Avaliação da capacidade de polimerização de um novo dispositivo à base de LED à bateria *Journal of American Dental Association - Brasil* **4**: 373-7.
- Aw TC & Nicholls JI (2001) Polymerization shrinkage of densely-filled resin composites *Operative Dentistry* **26(5)** 498-504.
- Brackett WW, Haisch LD & Covey DA (2000) Effect of plasma arc curing on the microleakage of class V resin-based composite restorations. *American Journal of Dentistry* **13(3)** 121-122.
- Burmann P, Cardoso PC, Silveira B, Casagrande L & Gazolla J (2000) O efeito de diferentes técnicas de fotopolimerização sobre a microinfiltração *Pesquisa Odontológica Brasileira* **14**: 56 (Abstr A048).
- Carvalho RM, Pereira JC, Yoshiyama M & Pashley DH (1996) A review of polymerization contraction: the influence of stress development versus stress relief. *Operative Dentistry* **21(1)** 17-24.
- Chen HY, Manhart J, Hickel R & Kunzelmann KH (2001) Polymerization contraction stress in light-cured packable composite resins *Dental Materials* **17(3)** 253-259.

- Davidson CL, De Gee AJ & Feilzer A (1984) The competition between the composite-dentin bond strength and the polymerization contraction stress *Journal of Dental Research* **63(12)** 1396-1399.
- Davidson CL & Feilzer AJ (1997) Polymerization shrinkage and polymerization shrinkage stress in polymer-based restoratives *Journal of Dentistry* **25(6)** 435-440.
- Feilzer AJ, De Gee AJ & Davidson CL (1990) Quantitative determination of stress reduction by flow in composite restorations *Dental Materials* **6(3)** 167-171
- Feilzer AJ, De Gee AJ & Davidson CL (1987) Setting stress in composite resin in relation to configuration of the restoration *Journal of Dental Research* **66(11)** 1636-1639.
- Friedl KH, Schmaltz G, Hiller KA & Markl A (2000) Marginal adaptation of class V restorations with and without "soft-start" polymerization *Operative Dentistry* **25(1)** 26-32.
- Hasegawa T, Itoh K, Yukitani W, Wakumoto S & Hisamitsu H (2001) Depth of cure and marginal adaptation to dentin of xenon lamp polymerized resin composites. *Operative Dentistry* **26(6)** 585-590.
- Jandt KD, Mills RW, Blackwell GB & Ashworth SH (2000) Depth of cure and compressive strength of dental composites cured with blue light emitting diodes (LEDs) *Dental Materials* **16(1)** 41-47.

- Knezevic A, Tarle Z, Meniga A, Sutalo J, Pichler G & Ristic M (2001) Degree of conversion and temperature rise during polymerization of composite resin samples with blue diodes *Journal of Oral Rehabilitation* **28(6)** 586-591.
- Koran P & Kurschner R (1998) Effect of sequential versus continuous irradiation of a light-cured resin composite on shrinkage, viscosity, adhesion, and degree of polymerization *American Journal of Dentistry* **10(1)** 17-22.
- Kurachi C, Tuboy AM, Magalhães DV & Bagnato VS (2001) Hardness evaluation of a dental composite polymerized with experimental LED-based devices *Dental Materials* **17(4)** 309-315.
- Li Y, Swartz ML, Phillips RW, Moore BK & Roberts TA (1985) Effect of filler content and size on properties of composites *Dental Materials* **64(12)** 1396-1401.
- Mehl A, Hickel R & Kunzelmann KH (1997) Physical properties and gap formation of light-cured composites with and without 'soft-start-polymerization' *Journal of Dentistry* **25(3-4)** 321-330.
- Mills RW, Jandt KD & Ashworth SH (1999) Dental composite depth of cure with halogen and blue light diode technology *British Dental Journal* **186(8)** 388-91.
- O'Brien WJ ed (1997) *Dental materials and their selection* 2nd edition Illinois Quintessence Publishing Co pp 97-114.
- Park SH, Krejci I & Lutz F (2002) Microhardness of resin composite polymerized by plasma arc or conventional visible light curing *Operative Dentistry* **27(1)**

30-37.

Peutzfeldt A, Sahafi A & Asmussen E (2000) Characterization of resin composites polymerized with plasma arc curing units *Dental Materials* **16(5)** 330-336.

Sahafi A, Peutzfeldt A & Asmussen E (2001) Soft-Start polymerization and marginal gap formation in vitro *American Journal of Dentistry* **14(3)** 145-147.

Shono Y, Ogawa T, Terashita M, Carvalho RM, Pashley EL & Pashley DH (1999) Regional measurement of resin-dentin bonding as an array *Journal of Dental Research* **78(2)** 699-705.

Shono Y, Terashita M, Pashley EL, Brewer PD & Pashley DH (1997) Effects of cross-sectional area on resin-enamel tensile bond strength *Dental Materials* **13(5)** 290-296.

Silikas N, Eliades G & Watts DC (2000) Light intensity effects on resin-composite degree of conversion and shrinkage strain *Dental Materials* **16(4)** 292-296.

Stahl F, Ashworth SH, Jandt KD & Mills RW (2000) Light-emitting diode (LED) polymerization of dental composites: flexural properties and polymerization potential *Biomaterials* **21(13)** 1379-85.

Uno S & Asmussen E (1991) Marginal adaptation of a restorative resin polymerized at reduced rate *Scandinavian Journal Dental Research* **99(5)** 440-444.

Unterbrink GL & Muessner R (1995) Influence of light intensity on two restorative systems *Journal of Dentistry* **23(3)** 183-189.

Yap AUJ, Ng SC & Siow KS (2001) Soft-start polymerization: influence on

effectiveness of cure and post-gel shrinkage *Operative Dentistry* **26(3)** 260-266.

Yap AUJ, Soh MS & Siow KS (2002) Post-gel shrinkage with pulse activation and soft-start polymerization *Operative Dentistry* **27(1)** 81-87.

Table 1: Polymerization techniques and resin composites used in this study.

Groups	Polymerization techniques	Resin Composites
G1	Soft-start light curing (halogen lamp)	Microhybrid
G2	Soft-start light curing (halogen lamp)	Packable
G3	LED light curing	Microhybrid
G4	LED light curing	Packable
G5	Plasma Arc curing	Microhybrid
G6	Plasma Arc curing	Packable
G7	Conventional light curing (halogen lamp)	Microhybrid
G8	Conventional light curing (halogen lamp)	Packable

Table 2: Microtensile bond strength values (Mean) in MPa for all polymerization techniques and resin composites.

Polymerization Techniques	Resin Composites			
	Microhybrid		Packable	
	Mean (MPa)	SD	Mean (MPa)	SD
Soft-start light curing	17.86 A a	5.38	12.45 A b	6.36
LED light curing	17.89 A a	6.36	15.48 A b	4.32
Plasma Arc curing	16.80 A a	6.78	16.25 A b	4.36
Conventional light curing	16.06 A a	4.60	13.83 A b	5.73

CV=38.29%

SD = Standard Deviation

Means followed by different letters were statistically different when analyzed by Tukey test ($p < 0.05$). Capital letters indicate comparisons among polymerization techniques (down). Small letters indicate comparison between resin composites (across).

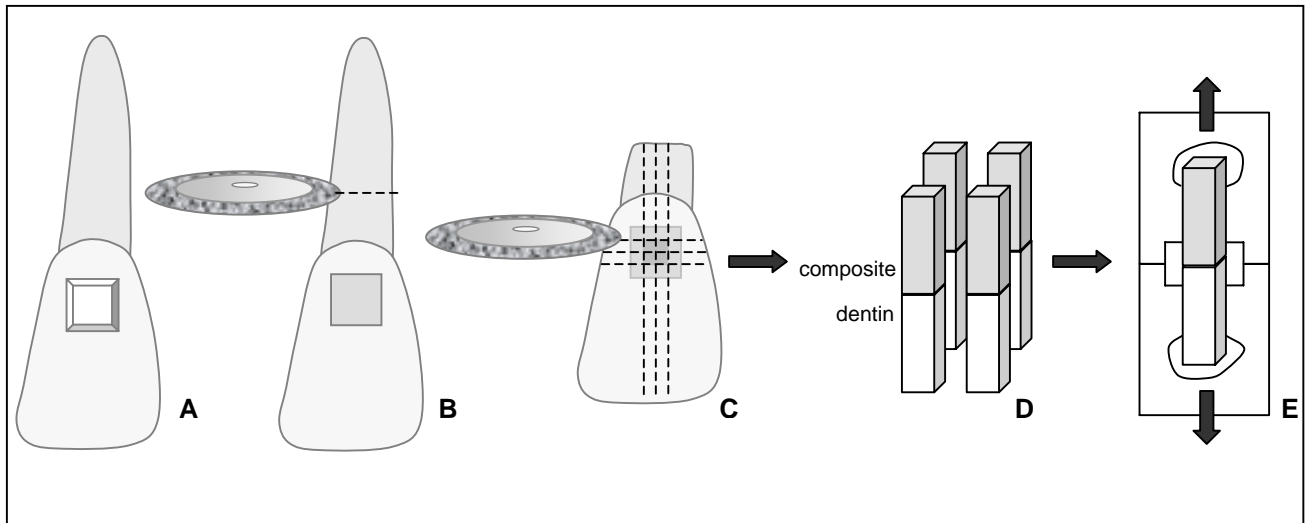

Figure 1. A: Localization of cavity; B: Sectioning the root from the coronal portion of the filled tooth; C: Section of coronal portion of teeth in small sticks; D: Sticks of central portion of restoration, with a rectangular cross-sectional area of approximately 1 mm²; E: Stick fixed to matrix with cyanoacrylate adhesive and posited in a testing apparatus for microtensile bond test.

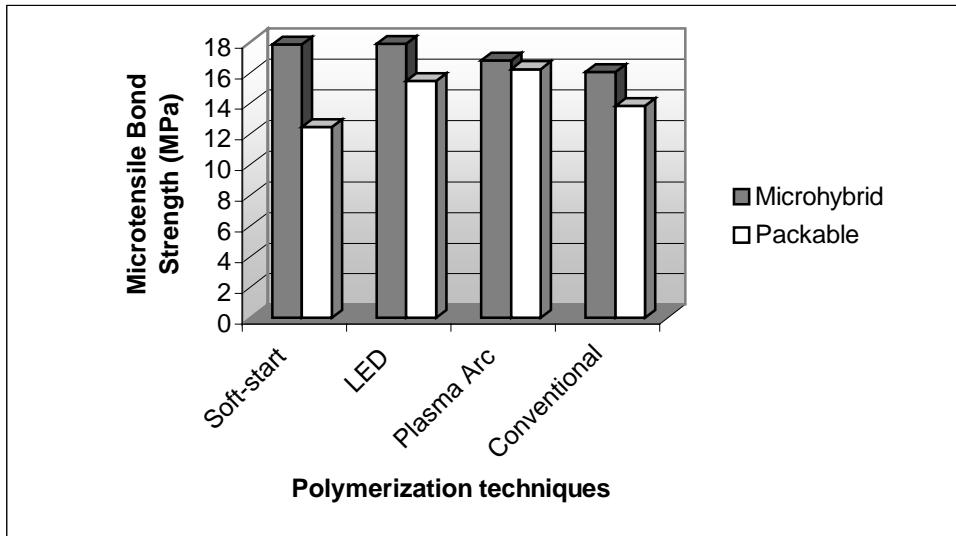

Figure 2. Microtensile bond strength of microhybrid and packable resin composites restorations for each polymerization technique.

4. Considerações Finais

Os resultados deste trabalho, composto por cinco artigos científicos, mostraram que as técnicas de polimerização que utilizam baixa intensidade inicial de luz, como as técnicas *soft-start*, progressiva e *pulse delay*, provavelmente não diminuíram o estresse de contração de polimerização das resinas compostas a ponto de afetar a microinfiltração das restaurações.

Embora as técnicas de polimerização *soft-start* e *pulse delay* não tenham afetado a microdureza das restaurações de resina composta, essas técnicas também não reduziram o tamanho das fendas marginais, quando comparadas com a polimerização convencional.

Assim, não foram observadas vantagens na utilização das técnicas de polimerização *soft-start*, *pulse delay* e progressiva, quando comparadas à convencional. Além disso, a microdureza das restaurações de resina composta polimerizadas com a técnica progressiva foi menor que a das restaurações polimerizadas com as técnicas *soft-start* e convencional, indicando menor grau de polimerização.

A polimerização com arco de plasma de Xenônio tem a grande vantagem de reduzir o tempo de polimerização para 3 segundos para as resinas compostas microhíbridas e para 6 segundos para as resinas compostas condensáveis. Para uma resina composta microhíbrida, a polimerização com arco de plasma de Xenônio apresentou resultados de microdureza, microinfiltração e formação de

fendas marginais similares à polimerização convencional. Entretanto, quando foi utilizada uma resina composta condensável, as restaurações polimerizadas com arco de plasma de Xenônio exibiram maior microinfiltração que aquelas polimerizadas com a técnica convencional. Para ambas as resinas compostas (microhíbrida e condensável), a microdureza das restaurações não foi afetada pela polimerização com arco de plasma de Xenônio.

Assim como as técnicas de polimerização *soft-start* e LED, a polimerização com arco de plasma de Xenônio não afetou a adesão de restaurações de resinas compostas, quando comparada à polimerização convencional. No entanto, aparelhos fotopolimerizadores de arco de plasma de Xenônio apresentam uma desvantagem: o alto custo. Deve-se avaliar o custo-benefício da aquisição desses aparelhos, que reduzem o tempo de polimerização para poucos segundos, apresentando resultados similares à polimerização convencional, só que a um alto custo.

As restaurações de resina composta polimerizadas com aparelhos à base de LEDs também apresentaram resultados de microinfiltração similares às restaurações polimerizadas com a técnica convencional, para uma resina composta microhíbrida e uma condensável. Para a resina composta condensável, as restaurações polimerizadas com o aparelho composto por seis LEDs apresentaram maior microinfiltração que aquelas polimerizadas com o aparelho composto por dezenove LEDs. Isso pode indicar que o número ou o tipo de LEDs de cada aparelho pode ter papel importante nas propriedades da resina composta. A

possibilidade de bons resultados nas análises de microinfiltração e resistência adesiva, utilizando a polimerização com LEDs, foi observada neste estudo, embora alguns trabalhos tenham relatado valores inferiores de microdureza, quando a polimerização com LEDs é comparada à polimerização convencional. Isso indica que mais pesquisas sobre os aparelhos à base de LEDs precisam ser realizadas, para que ocorra um maior desenvolvimento dessa tecnologia, possibilitando resultados similares à polimerização convencional. Trata-se de uma tecnologia promissora, pois esses aparelhos possibilitam maior aproveitamento pela resina composta da luz emitida, uma vez que o pico de emissão dos LEDs coincide com o pico de absorção da canforoquinona. Além disso, esses aparelhos apresentam uma vida útil maior, sem degradação dos emissores de luz e a um baixo custo.

Embora, neste estudo, muitas vezes não tenham sido observadas diferenças entre as técnicas de polimerização, foi observada a influência do material restaurador na microinfiltração e na adesão. No Capítulo III, observaram-se diferenças entre as técnicas de polimerização, quando foi utilizada a resina composta condensável Surefil. Já no Capítulo IV, as restaurações de resina composta condensável (Surefil) apresentaram maior microinfiltração que as restaurações de resina composta microhíbrida (Z250), e somente foi observada diferença entre os aparelhos fotopolimerizadores para a resina composta microhíbrida. Isso mostra que alguns materiais restauradores podem ser mais suscetíveis às diferentes técnicas de polimerização e às variações de intensidade de luz. No Capítulo V, a adesão das restaurações de resina composta condensável (Solitaire 2) foi menor que a das restaurações de resina composta microhíbrida

(Z250). Essas diferenças entre as resinas compostas podem estar relacionadas à composição da matriz e ao tipo, tamanho e quantidade de partículas de carga.

Assim, foi possível observar que ainda é necessário maior aperfeiçoamento das técnicas de polimerização e maior desenvolvimento dos sistemas de polimerização que envolvem novas tecnologias, para que seja possível obter restaurações de resina composta com propriedades adequadas, com maior longevidade e a um custo reduzido. Além disso, muita atenção deve ser dada à composição das resinas compostas, buscando sempre materiais que apresentem reduzida contração de polimerização e propriedades físicas e mecânicas adequadas.

5. Conclusões

De acordo com as metodologias empregadas e a análise dos resultados, pode-se concluir que:

1. As técnicas de polimerização *soft-start*, progressiva e convencional, bem como as técnicas de inserção da resina composta não reduziram a microinfiltração das restaurações. Ocorreu diminuição da microdureza do material próximo à margem gengival, e quando a polimerização progressiva foi utilizada;

2. Não foi observada diferença entre as técnicas de polimerização *soft-start*, *pulse delay*, arco de plasma de Xenônio, alta intensidade (halógena) e convencional quanto à microinfiltração e à formação de fendas. Entretanto, a termociclagem aumentou significativamente a formação de fendas, e não foi observada correlação entre os testes de microinfiltração e de formação de fendas;

3. Para uma resina composta microhíbrida, as técnicas de polimerização *soft-start*, arco de plasma de Xenônio e convencional apresentaram resultados similares de microinfiltração. Já para uma resina composta condensável, a técnica de polimerização convencional foi comparável à *soft-start* e melhor que com arco de plasma de Xenônio. Quanto à microdureza, todas as técnicas de polimerização apresentaram resultados similares, mas a superfície de topo sempre apresentou os maiores valores, seguido pelas superfícies média e de base;

4. Os aparelhos fotopolimerizadores à base de LEDs apresentaram comportamento similar à polimerização convencional com luz halógena, quanto à

microinfiltração, para duas resinas compostas. Entretanto, as restaurações de resina composta condensável apresentaram maior microinfiltração que as restaurações de resina composta microhíbrida. Para a resina composta microhíbrida, as restaurações polimerizadas com o aparelho composto por 6 LEDs apresentaram microinfiltração significativamente maior que as restaurações polimerizadas com o aparelho composto por 19 LEDs;

5. As técnicas de polimerização *soft-start*, LED e arco de plasma de Xenônio não afetaram a adesão de restaurações de resinas compostas, quando comparadas com a polimerização convencional (luz halógena). As restaurações de resina composta condensável apresentaram menor resistência adesiva que as restaurações de resina composta microhíbrida, para todas as técnicas de polimerização.

6. Referências Bibliográficas*

- Aboushala A, Kugel G, Hurley E. Class II composite resin restorations using glass-ionomer liners: Microleakage studies. *J Clin Pediatr Dent* 1996; 21(1): 67-71.
- Alani AH, Toh CG. Detection of microleakage around dental restorations: a review. *Oper Dent* 1997; 22(4): 173-185.
- Alonso RCB, Sinhoreti MAC, Consani S *et al.* Efeito do método de polimerização sobre a infiltração marginal em restaurações com compósitos odontológicos. *Pesq Odontol Bras* 2000; 14: 55 (Abstr I353).
- Althoff O, Hartung M. Advances in light curing. *Am J Dent* 2000; 13(Spec No): 77D-81D.
- Andrade MF, Rastelli ANS, Saadi RS *et al.* Avaliação da capacidade de polimerização de um novo dispositivo à base de LED à bateria. *J Am Dent Assoc - Brasil* 2001; 4: 373-7.
- Applequist EA, Meiers JC. Effect of bulk insertion, prepolymerized resin composite balls, and beta-quartz inserts on microleakage of class V resin composite restorations. *Quintessence Int* 1996; 27(4): 253-8.
- Asmussen, E. Restorative resins: hardness and strenght vs quantity of remaining double bonds. *Scand J Dent Res* 1982; 90(6): 484-9.
- Aw TC; Nicholls JI. Polymerization shrinkage of densely-filled resin composites. *Oper Dent* 2001; 26(5): 498-504.
- Bayne SC, Heyman HO, Swift Jr. EJ. Update on dental composite restoration *J Am Dent Assoc* 1994; 125(6): 687-701.
- Bedran de Castro AK, Hara AT, Pimenta LAF. Influence of collagen removal on

* De acordo com as normas da revista Pesquisa Odontológica Brasileira

- shear bond strength of one-bottle adhesive systems in dentin. *J Adhesive Dent* 2000; 2(4): 271-7.
- Brackett WW, Haisch LD, Covey DA. Effect of plasma arc curing on the microleakage of class V resin-based composite restorations. *Am J Dent* 2000; 13(3): 121-2.
- Burmann P, Cardoso PC, Silveira B *et al.* O efeito de diferentes técnicas de fotopolimerização sobre a microinfiltração. *Pesqui Odontol Bras* 2000; 14: 66 (Resumo n. A048)
- Cardoso PEC, Burmann PA, Soares LF *et al.* Microinfiltração em restaurações oclusais de resina composta fotopolimerizadas pela técnica do pulso atrasado. *Pesq Odontol Bras* 2000; 14: 66 (Abstr 47).
- Carvalho RM, Pereira JC, Yoshima M *et al.* A review of polymerization contraction: the influence of stress development versus stress relief. *Oper Dent* 1996; 21(1): 17-24.
- Caughman WF, Caughman GB, Shiflett RA *et al.* Correlation of cytotoxicity, filler loading and curing time of dental composites. *Biomaterials* 1991; 12(8): 737-40.
- Chen HY, Manhart J, Hickel R *et al.* Polymerization contraction stress in light-cured packable composite resins. *Dent Mater* 2001; 17(3): 253-9.
- Chuang SF, Liu JK, Jin YT. Microleakage and internal voids in class II composite restorations with flowable composite linings. *Oper Dent* 2001; 26(2): 193-200.
- Crim GA, Swartz ML, Phillips RW. Comparison of four thermocycling techniques. *J Prosthet Dent* 1985; 53(1): 50-3.
- Crim GA, Chapman KW. Reducing microleakage in class II restorations: an in vitro study. *Quintessence Int* 1994; 25(11): 781-5.
- Crim GA, Mattingly SL. Evaluation of two methods for assessing marginal leakage.

- J Prosthet Dent 1981; 45(2): 160-3.
- Davidson CL, Feilzer AJ. Polymerization shrinkage and polymerization shrinkage stress in polymer-based restoratives. J Dent 1997; 25(6): 435-40.
- Davidson CL, De Gee AJ, Feilzer A. The competition between the composite-dentin bond strength and the polymerization contraction stress. J Dent Res 1984; 63(12): 1396-9.
- Donly KJ, Jensen ME, Reinhardt J *et al.* Posterior composite polymerization shrinkage in primary teeth: an in vitro comparison of three restorative techniques. Pediat Dent 1987; 9(1): 22-5.
- Eakle WS, Ito RK. Effect of insertion technique on microleakage in mesio-occlusodistal composite resin restorations. Quintessence Int 1990; 21(5): 369-74.
- Eick JD, Welch FH. Polymerization shrinkage of posterior composite resins and its possible influence on postoperative sensitivity. Quintessence Int 1986; 17(2): 103-11.
- Feilzer AJ, De Gee AJ, Davidson CL. Quantitative determination of stress reduction by flow in composite restorations. Dent Mater 1990; 6(3): 167-71.
- Feilzer AJ, De Gee AJ, Davidson CL. Setting stress in composite resin in relation to configuration of the restoration. J Dent Res 1987; 66(11): 1636-9.
- Feilzer AJ, Dooren LH, De Gee AJ *et al.* Influence of light intensity on polymerization shrinkage and integrity of restoration-cavity interface. Eur J Oral Sci 1995; 103(5): 322-6.
- Friedl KH, Schmaltz G, Hiller KA *et al.* Marginal adaptation of class V restorations with and without "soft-start" polymerization. Oper Dent 2000; 25(1): 26-32.
- Gallo JR, Comeaux R, Haines B *et al.* Shear bond strength of four filled dentin bonding systems Oper Dent 2001; 26(1): 44-7.

- Going RB. Microleakage around dental restorations: a summarizing review. *J Am Dent Assoc* 1972; 84(6): 1349-57.
- Goracci G, Mori G, Bazzucchi M. Marginal seal and biocompatibility of fourth generation bonding agent. *Dent Mat* 1995; 11(6): 343-7.
- Goracci G, Mori G, De' Martinis LC. Curing light intensity and marginal leakage of resin composite restorations. *Quintessence Int* 1996; 27(5): 355-62.
- Hansen EK, Asmussen E. Visible-light curing units: correlation between depth of cure and distance between exit window and resin surface. *Acta Odontol Scand* 1997; 55(3): 162-6.
- Hasegawa T, Itoh K, Yukitani W *et al.* Depth of cure and marginal adaptation to dentin of xenon lamp polymerized resin composites. *Oper Dent* 2001; 26(6): 585-90.
- Helvatjoglou-Antoniad M, Papadogianis Y, Koliniotou-Kubia E *et al.* Surface hardness of light-cured and self-cured composite resins. *J Prosthet Dent* 1991; 65(2): 215-20.
- Hilton TJ, Schwartz RS, Ferracane JL. Microleakage of four class II resin composite insertion techniques at intraoral temperature. *Quintessence Int* 1997; 28(2): 135-44.
- Jandt KD, Mills RW, Blackwell GB *et al.* Depth of cure and compressive strength of dental composites cured with blue light emitting diodes (LEDs). *Dent Mater* 2000; 16(1): 41-7.
- Kays BT, Sneed WD, Nuckles DB. Microhardness of class II composite resin restorations with different matrices and light positions. *J Prosthet Dent* 1991; 65(4): 487-90.

- Kidd EAM. Microleakage: a review. *J Dent* 1976; 4(5): 199-206.
- Knezevic A, Tarle Z, Meniga A *et al.* Degree of conversion and temperature rise during polymerization of composite resin samples with blue diodes. *J Oral Rehabil* 2001; 28(6): 586-91.
- Konstantinos F. Microleakage reduction from newer esthetic restorative materials in permanent molars. *J Clin Pediatr Dent* 1998; 22(3): 221-9.
- Koran P; Kurschner R. Effect of sequential versus continuous irradiation of a light-cured resin composite on shrinkage, viscosity, adhesion, and degree of polymerization. *Am J Dent* 1998; 10(1): 17-22.
- Kurachi C, Tuboy AM, Magalhães DV *et al.* Hardness evaluation of a dental composite polymerized with experimental LED-based devices. *Dent Mater* 2001; 17(4): 309-15.
- Leinfelder KF. Posterior composite resin: the material and their clinical performance. *J Am Dent Assoc* 1995; 126(5): 663-76.
- Li Y, Swartz ML, Phillips RW *et al.* Effect of filler content and size on properties of composites. *Dent Mater* 1985; 64(12): 1396-1401.
- Liberman R, Gorfil C, Ben-Amar A. Reduction of microleakage in class II composite resin restoration using retentive pins. *J Oral Rehabil* 1996; 23(4): 240-3.
- Lutz F, Krejci I, Barbakow F. Restoration quality in relation to wedge-mediated light channeling. *Quintessence Int* 1992; 23(11): 763-7.
- Lutz F, Krejci I, Luescher B *et al.* (a) Improved proximal margin adaptation of class II composite resin restorations by use of light-reflecting wedges. *Quintessence Int* 1986; 17(10): 659-64.

- Lutz F, Krejci I, Oldenburg TR. (b) Elimination of polymerization stresses at the margins of posterior composite resin restorations: a new restorative technique. *Quintessence Int* 1986; 17(12): 777-84.
- Mandras RS, Retief DH, Russel CM. The effects of thermal and occlusal stresses on the microleakage of the Scotchbond 2 dentinal bonding system. *Dent Mater* 1991; 7(1): 63-7.
- Martinez A, Falcon J, Garcia-Godoy F *et al.* Soft-start system polymerization using a hybrid composite vs packable composite: microleakage study. *J Dent Res* 2000; 79: 535 (Abstr 3133).
- Medeiros IS. Dispositivos LED para polimerização de resinas compostas dentais: comparação com outras fontes de luz. São Carlos, 2001. 112p. [Tese (Mestrado) Universidade de São Paulo].
- Mehl A, Hickel R, Kunzelmann KH. Physical properties and gap formation of light-cured composites with and without 'softstart-polymerization'. *J Dent* 1997; 25(3-4): 321-30.
- Meiers JC, Kazemi R, Meier CD. Microleakage of packable composite resins. *Oper Dent* 2001; 26(2): 121-6.
- Mills RW, Jandt KD, Ashworth SH. Dental composite depth of cure with halogen and blue light diode technology. *Br Dent J* 1999; 186(8): 388-91.
- Momoi Y, Iwase H, Nakano Y *et al.* Gradual increases in marginal leakage of resin composite restorations with thermal stress. *J Dent Res* 1990; 69(10): 1659-63.
- Nakabayashi N, Saimi Y. Bonding to intact dentine. *J Dent Res* 1996; 75(9): 1706-15.
- Neiva IF, De Andrada MAC, Baratieri LN *et al.* An in vitro study of the effect of restorative technique on marginal leakage in posterior composites. *Oper Dent* 1998; 23(6): 282-9.

- Nomoto R, Uchida K, Hirasawa T. Effect of light intensity on polymerization of light-cured composite resins. *Dent Mater J* 1994; 13(2): 198-205.
- O'Brien WJ. *Dental materials and their selection*, 2nd edition, Illinois, 1997 Quintessence Publishing Co, 97p.
- Opdam NJM, Roeters FJM, Feilzer AJ *et al*. Marginal integrity and post operative sensitivity in class II resin composite restoration in vivo. *J Dent* 1998; 26(7): 555-62.
- Ota K, Kopel HM, Nakamura RM *et al*. Effect of light exposure time on the depth of curing in various composite resin systems. *Pediat Dent* 1985; 7(1): 19-22.
- Park SH, Krejci I, Lutz F. Microhardness of resin composites polymerized by plasma arc or conventional visible light curing. *Oper Dent* 2002; 27(1): 30-7.
- Peutzfeldt A, Sahafi A, Asmussen E. Characterization of resin composites polymerized with plasma arc curing units. *Dent Mater* 2000; 16(5): 330-6.
- Pimenta LAF. Avaliação da microinfiltração em restaurações de classe II em compósito realizadas com duas técnicas diferentes de inserção. Piracicaba, 1999. 94p. [Tese (Livre Docência) – FOP – UNICAMP].
- Pires JA, Cvitko E, Denehy GE *et al*. Effects of curing tip distance on light intensity and composite resin microhardness. *Quintessence Int* 1993; 24(7): 517-21.
- Rossomando KJ, Wendt Jr SL. Thermocycling and dwell times in microleakage evaluation for bonded restorations. *Dent Mater* 1995; 11(1): 47-51.
- Rueggeberg FA, Caughman WF, Curtis Jr JW. Effect of light intensity and exposure duration on cure of resin composite. *Oper Dent* 1994; 19(1): 26-32.
- Ruyter IE, Oysaed H. Conversion in different depths of ultraviolet and visible light activated composite materials. *Acta Odontol Scand* 1982; 40(3): 179-92.
- Sahafi A, Peutzfeldt A, Asmussen E. Soft-start polymerization and marginal gap formation in vitro. *Am J Dent* 2001; 14(3): 145-7.

- Shono Y, Ogawa T, Terashita M *et al.* Regional measurement of resin-dentin bonding as an array. *J Dent Res* 1999; 78(2): 699-705.
- Shono Y, Terashita M, Pashley El *et al.* Effects of cross-sectional area on resin-enamel tensile bond strength. *Dent Mater* 1997; 13(5): 290-296.
- Silikas N, Eliades G, Watts DC. Light intensity effects on resin composite degree of conversion and shrinkage strain. *Dent Mater* 2000; 16(4): 292-6.
- Stahl F, Ashworth SH, Jandt KD *et al.* Light-emitting diode (LED) polymerization of dental composites: flexural properties and polymerization potential. *Biomaterials* 2000; 21(13): 1379-85.
- Tjan AHL, Bergh BH, Lidner C. Effect of various incremental techniques on the marginal adaptation of class II composite resin restorations. *J Prosthet Dent* 1992; 67(1): 62-6.
- Uno S, Asmussen E. Marginal adaptation of a restorative resin polymerized at reduced rate. *Scand J Dent Res* 1991; 99(5): 440-4.
- Unterbrink GL, Muessner R. Influence of light intensity on two restorative systems. *J Dent* 1995; 23(3): 183-9.
- Walker RS, Burgess JO. Microleakage of class V composite restorations with different curing methods. *J Dent Res* 2000; 79: 161 (Abstr 143).
- Yap AUJ, Ng SC, Siow KS. Soft-start polymerization: influence on effectiveness of cure and post-gel shrinkage. *Oper Dent* 2001; 26(3): 260-6.
- Yap AUJ, Seneviratne C. Influence of light energy density on effectiveness of composite cure. *Oper Dent* 2001; 26(5): 460-6.
- Yap AUJ, Soh MS, Siow KS. Post-gel shrinkage with pulse activation and soft-start polymerization. *Oper Dent* 2002; 27(1): 81-7.

Obras Consultadas

1. MICHAELIS MODERNO DICIONÁRIO DA LÍNGUA PORTUGUESA. São Paulo: Melhoramentos, 1998.
2. FERREIRA, ABH *et al.* Novo Dicionário Aurélio da Língua Portuguesa. 2 ed. São Paulo: Nova Fronteira, 1999.
3. MARQUES, A & DRAPER, D. Dicionário Inglês-Português/ Português-Inglês. 5 ed. São Paulo: Ática, 1989.
4. CECCOTTI, HM & SOUSA, DD. Manual para normatização de dissertação e tese. Piracicaba: FOP - UNICAMP, 1999, 56p.
5. SOLIANI, SDO & SILVA, LF. Abreviaturas dos periódicos da biblioteca da FOP - UNICAMP e locais de publicação conforme o "World List of Scientific". Piracicaba: UNICAMP, 1995, 24p.

Anexo 1: Comprovante da publicação do artigo "Efeito das técnicas de inserção e ativação da resina composta sobre a microinfiltração e microdureza".

Pesqui Odontol Bras
2002;16(3):257-262

Dentística

Efeito das técnicas de inserção e ativação da resina composta sobre a microinfiltração e microdureza

Effect of techniques of composite resin insertion and polymerization on microleakage and microhardness

Cristiane Mariote Amaral*
Ana Karina Barbieri Bedran de Castro*
Luiz André Freire Pimenta**
Glaucia Maria Boni Ambrosano***

RESUMO: O objetivo deste trabalho foi avaliar a influência da técnica de ativação e de inserção da resina composta sobre a microinfiltração marginal e microdureza em restaurações classe II. Foram preparadas 180 cavidades que foram divididas em 6 grupos: G1 - incremento único + ativação convencional; G2 - incrementos vestibulo-linguais + ativação convencional; G3 - incremento único + ativação "soft-start"; G4 - incrementos vestibulo-linguais + ativação "soft-start"; G5 - incremento único + ativação progressiva; G6 - incrementos vestibulo-linguais + ativação progressiva. Todas as cavidades foram restauradas com o sistema Z100/Single Bond (3M). Após 1.000 ciclos térmicos (5 e 55°C), os espécimes foram imersos em solução aquosa de azul de metileno a 2%, por 4 horas e a microinfiltração foi avaliada. Metade dos espécimes foram incluídos em resina de poliestireno e a microdureza Knoop foi avaliada. Após o teste Kruskal-Wallis, não foi observada diferença significativa ($p > 0,05$) entre todas as técnicas de ativação e de inserção quanto à microinfiltração. Quanto à microdureza, após os testes análise de variância (2 fatores) e Tukey, não houve diferença significativa entre as técnicas restauradoras empregadas ($p > 0,05$), porém a ativação progressiva (G5 e G6) apresentou menor dureza Knoop ($p < 0,05$): G1 = 144,11; G2 = 143,89; G3 = 141,14; G4 = 142,79; G5 = 132,15; G6 = 131,67. Concluiu-se que as técnicas de ativação e de inserção da resina composta não afetaram a microinfiltração, mas ocorreu uma diminuição na microdureza do material quando a ativação progressiva foi utilizada.

UNITERMOS: Resinas compostas; Infiltração dentária; Luz; Restauração dentária permanente, métodos.

ABSTRACT: The aim of this study was to evaluate the influence of techniques of composite resin polymerization and insertion on microleakage and microhardness. One hundred and eighty class II cavities were prepared in bovine teeth and assigned to six groups: G1 - bulk filling + conventional polymerization; G2 - bucco-lingual increments + conventional polymerization; G3 - bulk filling + soft-start polymerization; G4 - bucco-lingual increments + soft-start polymerization; G5 - bulk filling + progressive polymerization; G6 - bucco-lingual increments + progressive polymerization. All cavities were restored with the Z100/Single Bond system (3M). After thermocycling, the samples were immersed in 2% methylene blue dye solution for 4 hours. Half of the samples were embedded in polystyrene resin, and Knoop microhardness was measured. The Kruskal-Wallis test did not reveal statistical differences ($p > 0.05$) between the polymerization and insertion techniques as to microleakage. Regarding microhardness, the two-way ANOVA and the Tukey test did not reveal statistical differences between the restorative techniques ($p > 0.05$), but progressive polymerization (G5 and G6) was associated with smaller Knoop microhardness values ($p < 0.05$): G = 144.11; G2 = 143.89; G3 = 141.14; G4 = 142.79; G5 = 132.15; G6 = 131.67. It was concluded that the evaluated polymerization and insertion techniques did not affect marginal microleakage, but a decrease in microhardness occurred when progressive polymerization was carried out.

UNITERMS: Composite resins; Dental leakage; Light; Dental restoration permanent, methods.

INTRODUÇÃO

A demanda por restaurações estéticas e a melhoria das propriedades físicas das resinas compostas permitiram que esse material fosse utilizado para restaurar dentes posteriores^{2,5}. Entretanto, as resi-

nas compostas ainda apresentam algumas propriedades desfavoráveis, tais como a contração de polimerização e o coeficiente de expansão térmica diferente da estrutura dental^{6,8,16}.

Vários estudos reportaram que é desenvolvido estresse significante durante a polimerização das

*Pós-Graduanda em Clínica Odontológica, Área de Dentística; **Professor Livre-Docente do Departamento de Odontologia Restauradora, Área de Dentística; ***Professora Assistente Doutora do Departamento de Odontologia Social, Área de Bioestatística - Faculdade de Odontologia de Piracicaba da Universidade Estadual de Campinas.

Amaral, CM, Castro, AKBB de, Pimenta, LAF, Ambrosano, GMB. Efeito das técnicas de inserção e ativação da resina composta sobre a microinfiltração e microdureza. *Pesqui Odontol Bras* 2002;16(3):257-262.

resinas compostas, produzindo forças que podem separar a resina da estrutura dental^{3,4,7}. Tem sido mostrado experimentalmente que uma lenta reação de polimerização das resinas compostas pode causar menos dano à interface da restauração, por aumentar o escoamento do material, diminuindo o estresse de contração de polimerização^{16,17,23}. Isto pode ser obtido através da polimerização "soft-start" ou com baixa intensidade de luz, sem comprometer a polimerização do material^{17,22}.

O objetivo deste trabalho foi avaliar qualitativamente a microinfiltração marginal de restaurações classe II em resina composta, realizadas com a técnica de incremento único ou de incrementos vestibulo-linguais, empregando-se a ativação convencional, "soft-start" e de intensidade progressiva, bem como avaliar a dureza do material restaurador para as técnicas empregadas.

MATERIAL E MÉTODOS

Análise da microinfiltração marginal

Foram selecionados 90 incisivos bovinos, que foram limpos e armazenados em solução de formol a 2%, pH 7,0. As coroas dos dentes foram seccionadas 5 mm acima da junção cimento-esmalte (JCE) com discos diamantados dupla-face (KG Sorensen) e preparos cavitários, simulando classe II, tipo "slot" vertical, foram realizados nas faces mesial e distal de cada dente (Figura 1). Os preparos foram realizados 1 mm abaixo da JCE (extensão ocluso-cervical de 6 mm), 3 mm de largura e 1,5 mm de profundidade.

Em todos os grupos, foi aplicado o sistema adesivo Single Bond (3M), seguindo-se as recomenda-

FIGURA 1 - A: posição de seccionamento dos dentes bovinos (5 mm acima da junção cimento-esmalte); B: localização e dimensões dos preparos cavitários - 1 mm abaixo da JCE (extensão ocluso-cervical de 6 mm), 3 mm de largura e 1,5 mm de profundidade.



FIGURA 2 - Descrição da técnica de inserção em incrementos vestibulo-linguais. A: primeiro incremento; B: segundo incremento; C: terceiro incremento.



Amaral, CM, Castro, AKBB de, Pimenta, LAF, Ambrosano, GMB. Efeito das técnicas de inserção e ativação da resina composta sobre a microinfiltração e microdureza. *Pesqui Odontol Bras* 2002;16(3):257-262.

ções do fabricante. A resina composta Z100 (3M), na cor A2, foi inserida de acordo com os seguintes grupos:

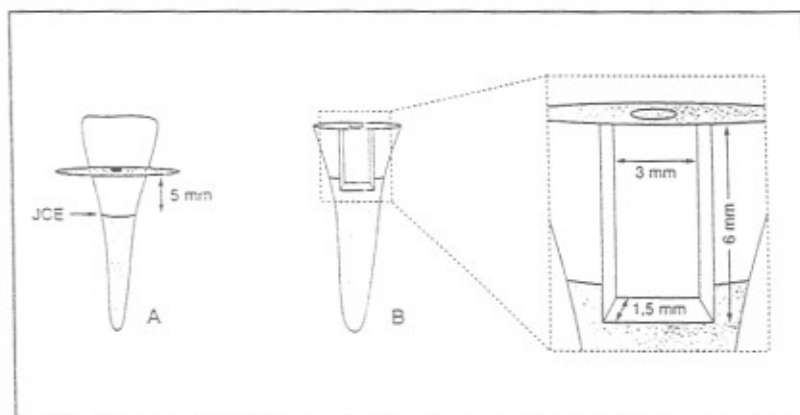
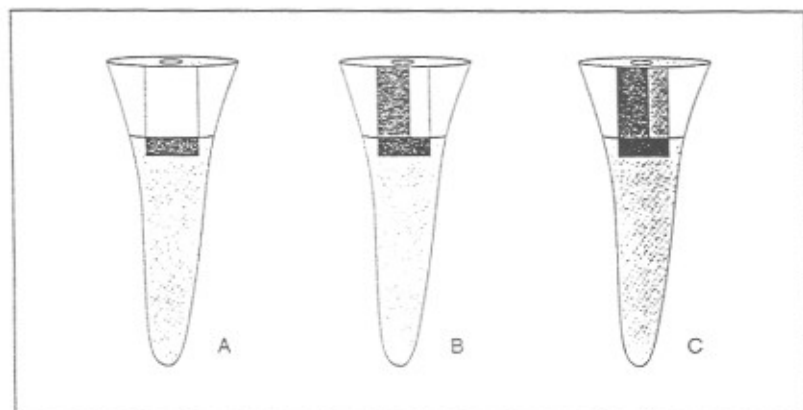
- G1 - incremento único com ativação convencional (Optilux 500 - Demetrom/Kerr) por 120 s, sendo 40 s por oclusal, 40 s por vestibular e 40 s por lingual.
- G2 - incrementos vestibulo-linguais (Figura 2)¹⁰ com ativação convencional (Optilux 500 - Demetrom/Kerr) por 40 s cada incremento.
- G3 - incremento único com ativação "soft-start" (Degulux Soft Start - Degussa Hüls) por 120 s, sendo 40 s por oclusal, 40 s por vestibular e 40 s por lingual.
- G4 - incrementos vestibulo-linguais¹⁶ com ativação "soft-start" (Degulux Soft Start - Degussa Hüls) por 40 s cada incremento.
- G5 - incremento único com ativação progressiva (KM 100-R - DMC Equipamentos) por 120 s, sendo 40 s por oclusal, 40 s por vestibular e 40 s por lingual.
- G6 - incrementos vestibulo-linguais¹⁶ com ativação progressiva (KM 100-R - DMC Equipamentos) por 40 s cada incremento.

A intensidade de luz dos aparelhos fotopolimerizadores foi medida e os seguintes valores foram observados: Optilux 500 (convencional) = 490 a 520 mW/cm²; Degulux Soft Start ("soft-start") = início 400 mW/cm² e após 20 segundos 710 a 720 mW/cm²; KM 100-R (progressiva) = aumento gradual da intensidade de 160 a 600 mW/cm² em 10 s, permanecendo em seguida na intensidade máxima.

Após o procedimento restaurador, foi realizado o polimento das restaurações com discos de óxido de alumínio Sof-Lex (3M) fino e extrafino. Em seguida, as restaurações foram submetidas à termociclagem em água destilada por 1.000 ciclos, em máquina de ciclagem térmica (Instrumental Instrumentos de Precisão), com banhos de 60 s às temperaturas de 5 ± 2°C e 55 ± 2°C, com 5 s de tempo de transferência. O vedamento dos canais dos dentes bovinos foi realizado com cola epóxica (Araldite®) e também foram aplicadas duas camadas de esmalte cosmético (Risqué - Niasi S.A.), respeitando-se a distância limite de 1 mm da margem cervical da restauração.

Todos os dentes ficaram imersos em solução aquosa de azul de metileno a 2% (pH 7,0) por 4 horas, depois foram lavados em água corrente e secos com papel absorvente. Finalmente, cada dente foi seccionado verticalmente, passando pelo centro da

restauração, com discos diamantados dupla-face. A microinfiltração na margem gengival foi avaliada por 2 examinadores calibrados, em concordância, utilizando-se lupa estereoscópica (MEJJI-2000), com aumento de 60 vezes, seguindo-se os critérios abaixo:

- Grau 0 - ausência de corante na interface dente-restauração.
- Grau 1 - penetração de corante até o primeiro terço da parede gengival.
- Grau 2 - penetração de corante até o intervalo entre o primeiro e o segundo terço da parede gengival.
- Grau 3 - com penetração de corante até o intervalo entre o segundo terço e o terceiro terço da parede gengival.
- Grau 4 - penetração de corante atingindo ou ultrapassando o ângulo áxio-cervical.

Os resultados da análise de microinfiltração foram submetidos ao teste de Kruskal-Wallis, ao nível de significância de 5% (p < 0,05).

Análise da microdureza

Após a avaliação da microinfiltração, 15 metades de restaurações de cada grupo foram seccionadas com discos diamantados dupla-face e foram agrupadas a cada três, dentro de tubos de PVC de ¾ de polegada, os quais foram preenchidos com resina de poliestireno (Cromex). Estes corpos-de-prova receberam acabamento e polimento utilizando-se lixas de óxido de alumínio (Carborundum Abrasivos), com granulações 400, 600 e 1.000, montadas em politriz elétrica rotativa (Maxigrind - Solotest), refrigerada com água. O polimento final foi realizado com discos de feltro (Imptech International) associados a pastas de diamante (Imptech International) de 3 µm e 1 µm, com refrigeração a óleo mineral (Arotec Ind. Com. Ltda.).

O ensaio de microdureza foi realizado utilizando-se um microdurômetro (Future Tech - FM - 1E) e o penetrador tipo Knoop, com carga de 25 g e duração de aplicação de 20 s. As indentações foram localizadas a 100, 2.500 e 5.000 µm de distância da margem gengival, sendo 3 indentações para cada uma destas localizações.

As medidas foram transformadas em número de dureza Knoop e as médias de dureza para cada profundidade avaliada e para cada grupo experimental foram calculadas e submetidas à análise de variância (2 fatores), realizada em esquema de parcela subdividida e ao teste Tukey, ao nível de significância de 5% (p < 0,05).

Amaral, CM, Castro, AKBB de, Pimenta, LAF, Ambrosano, GMB. Efeito das técnicas de inserção e ativação da resina composta sobre a microinfiltração e microdureza. *Pesqui Odontol Bras* 2002;16(3):257-262.

RESULTADOS

Na avaliação da microinfiltração, não foi observada diferença significativa entre as técnicas de inserção nem entre as técnicas de ativação utilizadas. A distribuição da frequência dos escores é apresentada na Tabela 1.

Quanto à microdureza, não foi observada diferença estatisticamente significativa entre as técnicas de inserção empregadas, mas a ativação progressiva apresentou dureza significativamente menor da resina composta que as outras técnicas de ativação ($p < 0,05$). A dureza na porção mais profunda da restauração (a 100 μm da margem gengival) também foi significativamente menor que nas outras regiões, para todas as técnicas de ativação ($p < 0,05$) (Tabela 2).

DISCUSSÃO

Várias técnicas têm sido estudadas para reduzir o estresse de contração de polimerização e, conseqüentemente, a infiltração marginal¹⁴. Esses estudos incluem o uso de cunhas refletivas^{15,16}, técnicas de inserção^{2,13,18,21} e variações na intensidade de luz^{10,11,17,22,23}.

Neste trabalho, não foi observada diferença estatisticamente significativa entre as técnicas de inserção empregadas em relação à microinfiltração. Esses resultados confirmam alguns estudos de microinfiltração, que compararam o emprego das técnicas de inserção de incremento único, incrementos horizontais, oblíquos e vestibulo-linguais, em que não foram observadas diferenças significativas entre as técnicas de inserção^{9,13,21}.

TABELA 1 - Frequências de escores de infiltração marginal em função do aparelho fotopolimerizador e técnica restauradora.

Ativação	Técnica de inserção	Infiltração (escores)					Total global
		0	1	2	3	4	
Convencional	Inserção	0	1	2	3	4	
	Incremento único	23	7	0	0	0	30
	3 incrementos	19	7	1	0	2	29
"Soft-start"	Incremento único	15	12	0	0	0	27
	3 incrementos	20	10	1	0	0	31
Progressiva	Incremento único	16	13	0	1	0	30
	3 incrementos	17	12	1	0	1	31
Total global		110	61	3	1	3	178

TABELA 2 - Microdureza em função da técnica de inserção, da ativação e da profundidade da restauração.

Técnica de inserção	Ativação	Distância da parede gengival						Média geral
		100 μm		2.500 μm		5.000 μm		
		Média	DP	Média	DP	Média	DP	
Incremento único	Convencional	139	26	143	28	150	34	144 A
	"Soft-start"	137	20	143	23	143	21	141 A
	Progressiva	130	15	134	11	132	9	132 B
Média		136 b		140 ab		142 a		
3 incrementos	Convencional	140	26	147	24	144	23	144 A
	"Soft-start"	144	17	140	15	145	19	143 A
	Progressiva	129	7	131	9	135	5	132 B
Média		138 b		139 ab		141 a		

DP = desvio padrão. Médias seguidas de letras distintas (maiúsculas na vertical e minúsculas na horizontal), dentro de cada técnica, diferem entre si pelo teste de Tukey ($p < 0,05$). Não houve diferença significativa entre as técnicas de inserção ($p > 0,05$).

Amaral, CM, Castro, AKBB de, Pimenta, LAF, Ambrosano, GMB. Efeito das técnicas de inserção e ativação da resina composta sobre a microinfiltração e microdureza. *Pesqui Odontol Bras* 2002;16(3):257-262.

Um recente método, designado a reduzir o estresse de contração e melhorar a adaptação marginal, consiste na conversão inicialmente reduzida da resina composta, controlando a capacidade de escoamento da restauração^{8,10,22}. Um aumento no tempo de endurecimento de resinas compostas fotopolimerizáveis pode ser alcançado pela diminuição da intensidade de luz¹⁰.

Vários autores observaram menor formação de fendas quando intensidades menores de luz foram utilizadas^{10,11,17,22,23}. No entanto, outros estudos não encontraram diferença estatística quanto à penetração de corantes, quando diferentes intensidades de luz foram utilizadas^{13,17}. Neste estudo, também não foi observada diferença significativa na infiltração marginal quando diferentes técnicas de ativação foram utilizadas. No entanto, o aparelho "soft-start" usado neste trabalho apresenta intensidade de luz inicial de 400 mW/cm², intensidade bem maior que aquelas testadas em outros trabalhos (250 a 270 mW/cm²). A técnica de ativação progressiva também apresentou baixa intensidade de luz por poucos segundos, chegando rapidamente à intensidade de 600 mW/cm². Essas intensidades de luz provavelmente não permaneceram baixas por tempo suficiente para permitir uma lenta reação de polimerização.

Na avaliação da microdureza, não foi observada diferença estatisticamente significativa entre as técnicas de inserção avaliadas (incremento único e

incrementos vestibulo-linguais), mas observou-se uma diminuição significativa da microdureza a 100 µm da margem gengival, para todas as técnicas de ativação ($p < 0,05$). Isto pode ter ocorrido devido à dificuldade de polimerização em maiores profundidades, pois a distância da fonte de luz e a espessura de resina composta a ser fotoativada pode influenciar a qualidade da polimerização^{12,19,20}.

A técnica de ativação progressiva apresentou redução estatisticamente significativa da dureza da resina composta quando comparada às outras técnicas de ativação ($p < 0,05$). Embora esta diminuição da dureza não tenha afetado a microinfiltração das restaurações, supõe-se que a longo prazo isso poderá trazer algum efeito negativo, relacionado à degradação do material²⁰.

CONCLUSÕES

Concluiu-se que as técnicas de ativação e de inserção da resina composta não afetaram a microinfiltração de restaurações classe II, havendo, entretanto, uma diminuição na microdureza do material próximo à margem gengival e quando a ativação progressiva foi utilizada. Assim, deve-se observar o custo-benefício de cada técnica de ativação e a técnica de inserção de escolha deve ser aquela que possa garantir uma boa adaptação e a polimerização adequada do material restaurador.

REFERÊNCIAS

1. Alonso RCB, Sinhorette MAC, Consani S, et al. Efeito do método de polimerização sobre a infiltração marginal em restaurações com compósitos odontológicos. *Pesqui Odontol Bras* 2000;14:55 [resumo n. 1353].
2. Applequist EA, Meiers JC. Effect of bulk insertion, prepolymerized resin composite balls, and beta-quartz inserts on microleakage of class V resin composite restorations. *Quintessence Int* 1996;27(4):253-8.
3. Burmann P, Cardoso PC, Silveira B, et al. O efeito de diferentes técnicas de fotopolimerização sobre a microinfiltração. *Pesqui Odontol Bras* 2000;14:66 [Resumo n. A048].
4. Carvalho RM, Pereira JC, Yoshima M, Pashley DH. A review of polymerization contraction: the influence of stress development versus stress relief. *Oper Dent* 1996;21(1):17-24.
5. Crim GA, Chapman KW. Reducing microleakage in class II restorations: an *in vitro* study. *Quintessence Int* 1994;25(11):781-5.
6. Crim GA, Mattingly SL. Evaluation of two methods for assessing marginal leakage. *J Prosthet Dent* 1981;45(2):160-63.
7. Davidson CL, De Gee AJ, Feilzer A. The competition between the composite-dentin bond strength and the polymerization contraction stress. *J Dent Res* 1984;63(12):1396-9.
8. Davidson CL, Feilzer AJ. Polymerization shrinkage and polymerization shrinkage stress in polymer-based restoratives. *J Dent* 1997;25(6):435-40.
9. Eakle WS, Ito RK. Effect of insertion technique on microleakage in mesio-occlusodistal composite resin restorations. *Quintessence Int* 1990;21(5):369-74.
10. Feilzer AJ, Dooren LH, De Gee AJ, et al. Influence of light intensity on polymerization shrinkage and integrity of restoration-cavity interface. *Eur J Oral Sci* 1995;103(5):322-6.
11. Goracci G, Mori G, De' Martinis LC. Curing light intensity and marginal leakage of resin composite restorations. *Quintessence Int* 1996;27(5):355-62.
12. Hausen EK, Asmussen E. Visible-light curing units: correlation between depth of cure and distance between exit window and resin surface. *Acta Odontol Scand* 1997;55(3):162-6.

Amaral, CM, Castro, AKBB de, Pimenta, LAF, Ambrosano, GMB. Efeito das técnicas de inserção e ativação da resina composta sobre a microinfiltração e microdureza. *Pesqui Odontol Bras* 2002;16(3):257-262.

13. Hilton TJ, Schwartz RS, Ferracane JL. Microleakage of four class II resin composite insertion techniques at intraoral temperature. *Quintessence Int* 1997;28(2):135-44.
14. Kays BT, Sneed WD, Nuckles DB. Microhardness of class II composite resin restorations with different matrices and light positions. *J Prosthet Dent* 1991;65(4):487-90.
15. Lutz F, Krejci I, Luescher B, Oldenburg TR. Improved proximal margin adaptation of class II composite resin restorations by use of light-reflecting wedges. *Quintessence Int* 1986;17(10):659-64.
16. Lutz F, Krejci I, Oldenburg TR. Elimination of polymerization stresses at the margins of posterior composite resin restorations: a new restorative technique. *Quintessence Int* 1986;17(12):777-84.
17. Mehl A, Hickel R, Kunzelmann KH. Physical properties and gap formation of light-cured composites with and without "softstart-polymerization". *J Dent* 1997;25(3-4):321-30.
18. Neiva IF, De Andrada MAC, Baratieri LN, Monteiro Júnior S, Ritter AV. An *in vitro* study of the effect of restorative technique on marginal leakage in posterior composites. *Oper Dent* 1998;23(6):282-9.
19. Nomoto R, Uchida K, Hirasawa T. Effect of light intensity on polymerization of light-cured composite resins. *Dent Mater J* 1994;13(2):198-205.
20. Ota K, Kopel HM, Nakamura RM, Kikuchi S, Thanos CE. Effect of light exposure time on the depth of curing in various composite resin systems. *Pediat Dent* 1985;7(1):19-22.
21. Pimenta LAF. Avaliação da microinfiltração em restaurações de classe II em compósito realizadas com duas técnicas diferentes de inserção. Piracicaba [Tese de Livre-Docência]. Piracicaba: Faculdade de Odontologia da UNICAMP; 1999.
22. Uno S, Asmussen E. Marginal adaptation of a restorative resin polymerized at reduced rate. *Scand J Dent Res* 1991;99(5):440-4.
23. Unterbrink GL, Muessner R. Influence of light intensity on two restorative systems. *J Dent* 1995;23(3):183-9.

Recebido para publicação em 03/09/01
Enviado para reformulação em 08/04/02
Aceito para publicação em 13/05/02



Scientific Electronic Library Online

<http://www.scielo.br>

Parceria: FAPESP/BIREME

SciELO - Scientific Electronic Library Online é uma coleção eletrônica de revistas científicas disponíveis na Internet. A coleção traz os textos completos de artigos científicos, bases de dados e relatórios de uso e de impacto da literatura científica publicada no site.

Em operação desde 1997, atualmente estão disponíveis 29 revistas brasileiras nas áreas de ciências biológicas e da saúde, ciências sociais e humanas, ciências agrárias, física etc. Novas publicações são incluídas regularmente em várias especialidades.

Entre as revistas de nossa coleção, está a Pesquisa Odontológica Brasileira.

Consulte a Pesquisa Odontológica Brasileira (Revista de Odontologia da USP) na SciELO - <http://www.scielo.br/rousp>

Anexo 2: Comprovante da aceitação do artigo "*Microleakage and gap formation of resin composite restorations polymerized with different techniques*".

Luis Andre Freire Pimenta

De: <godoy@nova.edu>
Para: <lpimenta@fop.unicamp.br>
Enviada em: segunda-feira, 18 de novembro de 2002
Assunto: Manuscript Accepted

Dear Dr. Pimenta:

I am pleased to inform you that your manuscript "Microleakage and gap formation of resin composite restorations polymerized with different techniques" has been accepted for publication.

Before publication you will receive galleys for your approval.

Again, thank you for considering the American Journal of Dentistry!

Sincerely,

Prof. Dr. Franklin Garcia-Godoy
Editor

Anexo 3: Comprovante da publicação do artigo "Influence of polymerization technique on microleakage and microhardness of resin composite restorations".

Operative Dentistry, 2003, 28-2, 200-206

Influence of Polymerization Technique on Microleakage and Microhardness of Resin Composite Restorations

LMA Cavalcante • AR Peris • CM Amaral
GMB Ambrosano • LAF Pimenta

Clinical Relevance

The conventional technique for polymerization, used in association with a "packable" resin composite, provides similar resin-tooth interfacial seal to Soft-Start and better seal when compared to PAC; however, for a microhybrid resin composite, all techniques for polymerization present the same result.

SUMMARY

This study evaluated the influence of three polymerization techniques on microleakage and microhardness of Class II restorations using a microhybrid (Filtek Z250) and a "packable" resin composite (SureFil). The techniques, their respective light intensities and time used in relation to

the resin composites, are: Conventional (C)—800mW/cm² for 40 seconds; Soft-Start (SS1)—75mW/cm² for 10 seconds plus 518mW/cm² for 30 seconds; Soft-Start (SS2)—170mW/cm² for 10 seconds plus 518mW/cm² for 30 seconds and Plasma Arc Curing (PAC)—1,468mW/cm² for three or six seconds. One hundred and fifty-two "Vertical Slot type Class II cavities" at the mesial and distal surfaces were prepared and divided into eight groups (n=19). After the restorative procedure the samples were thermocycled (1,000 cycles at 5°C and 55°C), then immersed in 2% methylene blue dye solution for four hours. The microleakage was evaluated and the results analyzed by the Kruskal-Wallis and Multiple Comparisons tests. Ten samples from each group were randomly selected, embedded in polyester resin, polished and submitted to the Knoop microhardness test. ANOVA (split-plot) and Tukey's test ($p < 0.01$) revealed significant differences among depths: the hardness at the top surface was significantly higher followed by the middle and bottom surfaces. There was no significant difference in microleakage among the techniques when microhybrid resin composite was employed. However, when using a "packable" resin composite, the conventional technique for polymerization was comparable to Soft-Start and better than PAC.

Larissa Maria Assad Cavalcante, DDS, research assistant, Department of Restorative Dentistry, School of Dentistry of Piracicaba, University of Campinas, Piracicaba, São Paulo, Brazil

Alessandra Rezende Peris, DDS, graduate student, Department of Restorative Dentistry, School of Dentistry of Piracicaba, University of Campinas, Piracicaba, São Paulo, Brazil

Cristiane Mariote Amaral, DDS, MS, graduate student, Department of Restorative Dentistry, School of Dentistry of Piracicaba, University of Campinas, Piracicaba, São Paulo, Brazil

Gláucia Maria Boni Ambrosano, MS, PhD, assistant professor of Biostatistics, University of Campinas, Piracicaba, São Paulo, Brazil

*Luiz André Freire Pimenta, DDS, MS, PhD, associate professor of Restorative Dentistry, School of Dentistry of Piracicaba, University of Campinas, Piracicaba, São Paulo, Brazil

*Reprint request: UNICAMP, Av Limeira, 901 Caixa Postal 52, 13414-018 Piracicaba-SP—Brazil; e-mail: lpimenta@fop.unicamp.br

INTRODUCTION

Since their introduction to the market in the 1970s, light curing resin composites have been used for restorations, making dental procedures more conservative and able to serve esthetic demand. However, some material shortcomings, such as reduced wear resistance, marginal staining and excessive polymerization shrinkage and the sensitivity of the technique, have not been eliminated despite extensive research (Leinfelder, 1995). The success of the clinical performance of light curing resin composites is directly related to adequate polymerization and light intensity, which are crucial factors in obtaining optimal physical properties (Bayne, Heymann & Swift, 1994).

During the setting process, polymerization shrinkage of a resin composite can create forces that may disrupt the bond to cavity walls (Davidson, de Gee & Feilzer, 1984; Donly & others, 1987; Carvalho & others, 1996). This competition between contracting forces built up in the polymerizing resin and the bonds of adhesive resins to the wall of the restoration is one of the main causes of marginal failure and subsequent microleakage (Davidson & others, 1984; Mandras, Retief & Russel, 1991). Bond strength must be greater than contraction stress in order to obtain stable marginal adaptation. Microleakage permits the passage of bacteria, fluids, molecules and toxins and could encourage dentinal hypersensitivity, pulp inflammation, secondary caries and pulp necrosis (Kidd, 1976; Opdam & others, 1998).

Some studies have shown a relation between polymerization shrinkage and light intensity (Feilzer & others, 1995; Silikas, Eliades & Watts, 2000). As a result, different light units have been introduced into the market to minimize or control the polymerization shrinkage of composites.

Conventional lamps instantly provide maximal light intensity, which causes the resin composites to harden and produce a considerable increase in viscosity of the material (Goracci, Mori & Casa deMartinis, 1996). Composites cured at low light intensity have been shown to have a better marginal adaptation (Mandras & others, 1991; Uno & Asmussen, 1991). The theory is that a slower rate of conversion maintains a longer pre-gel phase, allowing for a better flow of the material, which decreases contraction stress in the filling material. However, this low intensity may affect the surface hardness and may be insufficient for ensuring mechanical stability (Unterbrink & Muessner, 1995; Pimenta, 1999).

Pre-polymerization at low intensity, followed by the final cure at high intensity, can allow for the flow of resin composite during setting. This method can reduce the width and length of marginal gaps without interfering with the physical properties of the restorations (Uno & Asmussen, 1991; Mehl, Hickel & Kunzelmann, 1997).

Now available, high-intensity light units based on a plasma system can reduce the long cure time and provide optimal properties in resin composite in a few seconds (Peutzfeldt, Sahafi & Asmussen, 2000; Park, Krejci & Lutz, 2002). However, the use of units with such high intensities could create more contraction forces and, consequently, marginal failure (Brackett, Haisch & Covey, 2000).

New methods of polymerization with varying intensities and curing times are on the market; therefore, it is necessary to analyze the effectiveness in the control of marginal adaptation and the quality of polymerization. This study evaluated the microleakage and microhardness of Class II resin composites using three available polymerization techniques—Conventional (Optilux501, Demetron/Kerr, Danbury, CT 06810, USA), Plasma Arc Curing (PAC, APOLLO 95E Elite, DMD Corp, Westlake Village, CA 91362, USA) and Soft-Start (Variable Intensity Polymerization, BISCO Inc, Schaumburg, IL 60193, USA) and two different resin composites—a microhybrid (Filtek Z250, 3M Dental Products, St Paul, MN 55144, USA) and a "packable" (SureFil, Dentsply/Caulk, Milford, DE 19963, USA).

METHODS AND MATERIALS

Microleakage Test

Seventy-six extracted bovine incisors were initially stored in a 2% formaldehyde buffered solution (Eick & Welch, 1986; de Castro, Hara & Pimenta, 2000; Gallo & others, 2001), after which debris was removed from the teeth. The crowns of the bovine teeth were cut off 5 mm above the cement-enamel junction (CEJ) with a double-faced diamond disk (KG Sorensen Ind Com Ltda, Barueri, SP 06442-110, Brazil).

"Vertical Slot type Class II cavities" at the mesial and distal surfaces were prepared with #245 carbide burs (KG Sorensen Ind Com Ltda) with a high-speed water-cooled handpiece (Kavo do Brasil AS, Joinville, SC 89221-040, Brazil). The burs were replaced after every 10 preparations to maintain uniformity. Butt-joint cavities had the following dimensions: 1.5 mm axial deep by 3 mm bucco-lingual wide and the gingival margin was located 1 mm apical to the CEJ.

In all groups, enamel and dentin etching with 35% phosphoric acid was performed for 15 seconds. Single Bond (3M Dental Products) adhesive system was applied following manufacturer's instructions. The resin composites SureFil (Dentsply/Caulk) and Filtek Z250 (3M Dental Products) were inserted in three horizontal increments and each increment was polymerized on the occlusal surface according to the following groups (n=19):

GROUP 1: SureFil (Dentsply/Caulk) resin composite and Conventional (C) polymerization technique for 40 seconds, each increment, showing an average intensity of 800 mW/cm²;

GROUP 2: SureFil (Dentsply/Caulk) resin composite using Soft-Start (SS1) polymerization technique (Variable Intensity Polymerizer, BISCO, Inc) showing an average initial intensity of 75 mW/cm² for 10 seconds and 518 mW/cm² for the subsequent 30 seconds;

GROUP 3: SureFil (Dentsply/Caulk) resin composite using Soft-Start (SS2) polymerization technique (Variable Intensity Polymerizer, BISCO, Inc) showing an average initial intensity of 170 mW/cm² for 10 seconds and 518 mW/cm² for the subsequent 30 seconds;

GROUP 4: SureFil (Dentsply/Caulk) resin composite using Plasma Arc Curing (PAC, APOLLO 95E Elite, DMD Corp) polymerization technique (APOLLO 95E Elite, DMD Corp) showing an average initial intensity of 1.468 mW/cm² for six seconds each increment, following manufacturer's instructions for this resin composite;

GROUP 5: Filtek Z-250 (3M Dental Products) resin composite and Conventional (C) polymerization (Optilux501, Demetron/Kerr) for 40 seconds each increment, showing an average intensity of 800 mW/cm²;

GROUP 6: Filtek Z250 (3M Dental Products) resin composite using Soft-Start (SS1) polymerization technique (Variable Intensity Polymerizer, BISCO, Inc) showing an average initial intensity of 75mW/cm² for 10 seconds and 518mW/cm² for the subsequent 30 seconds;

GROUP 7: Filtek Z250 (3M Dental Products) resin composite using Soft-Start (SS2) polymerization technique (Variable Intensity Polymerizer, BISCO, Inc) showing an average initial intensity of 170 mW/cm² for 10 seconds and 518 mW/cm² for the subsequent 30 seconds;

GROUP 8: Filtek Z250 (3M Dental Products) resin composite using the Plasma Arc Curing (PAC, APOLLO 95E Elite, DMD Corp) polymerization technique showing an average intensity of 1.468 mW/cm² for three seconds for each increment, following the manufacturer's instructions for this resin composite.

Following the restorative procedure, the teeth were stored in water at 37°C for 48 hours. All restorations were then finished with Sof-Lex (3M Dental Products) fine and ultra fine finishing disks and all specimens were thermocycled in a thermal cycling machine (MCT2-ANM instrumental, CA 94928, USA) for 1000 cycles at 5 ± 2°C and 55 ± 2°C with a dwell time of 60 seconds in distilled water and a five-second transfer time. Next, the apices and coronal surfaces were sealed with epoxy resin (Araldite, Brascola Ltda, São Bernardo do Campo, SP 09771-190, Brazil) and the teeth were coated with two applications of fingernail polish up to 1 mm from the gingival margins. All teeth were immersed in a freshly prepared aqueous 2% methylene blue solution (pH 7.0) for four hours at 37°C, then washed in water. Finally, each

tooth was sectioned vertically through the center of the restoration with a diamond disk (KG Sorensen Ind Com Ltda) at low speed.

Microleakage at the gingival margin was evaluated by two observers with an optical stereomicroscope (Meiji Techno Co, LTD, Iruma-gun Saitama 356, Japan) at 70x magnification and scored using the following criteria (Figure 1):

- 0 - No dye penetration.
- 1 - Dye penetration that extended up to 1/3 of preparation depth.
- 2 - Dye penetration greater than 1/3, up to 2/3 of preparation depth.
- 3 - Dye penetration extending to the axial wall.
- 4 - Dye penetration past the axial wall.

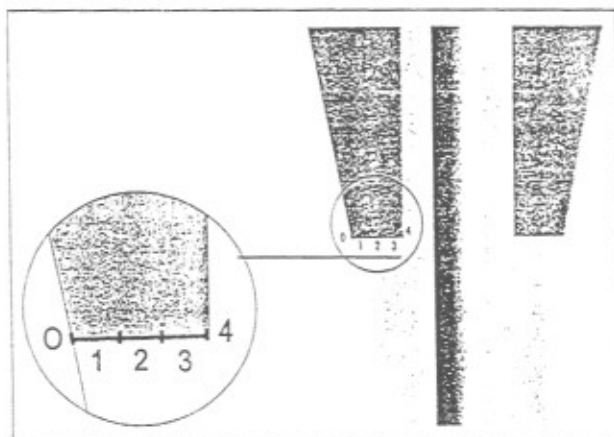

Figure 1. Diagram of microleakage evaluation criteria.

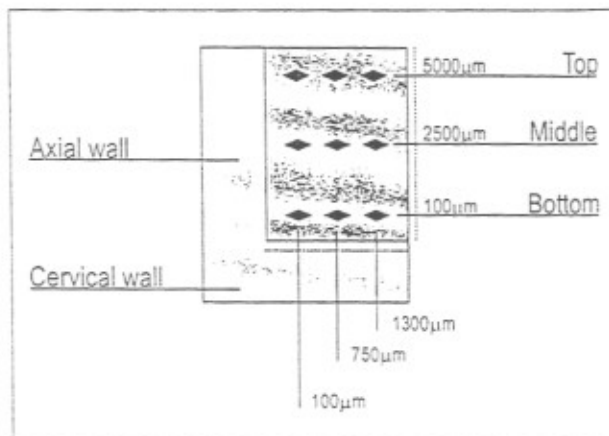

Figure 2. Diagram of Knoop indentation locations.

The results were analyzed by the Kruskal-Wallis and Multiple Comparisons tests.

Knoop Microhardness Test

After the microleakage evaluation, 10 sectioned restorations of each group were randomly selected and cut off with a double-faced diamond disk (KG Sorensen Ind Cóm Ltda). Twenty-six groups of three and one group of two restorations were placed in a 3/4 inch diameter PVC ring filled with self-curing polystyrene resin (Piraglass, Piracicaba, SP 13424-550, Brazil). The embedded restorations were ground on a water-cooled mechanical grinder (Maxigrind, Solotest, São Paulo, SP 01328, Brazil) using 400, 600 and 1000-grit Al_2O_3 abrasive paper (Saint-Gobain Abrasivos Ltda, Guarulhos, SP 07111150, Brazil). The restorations were polished on a mineral oil-cooled grinder using felts with diamond pastes of 3 μm and 1 μm (Equilam, Diadema, SP 09960-500, Brazil).

The Knoop microhardness test (Microhardness Tester, Future Tech FM-1E, Future Tech Corp, Tokyo 140, Japan) was performed using a 25g load for 20 seconds. The indentations were placed at 100, 2,500 and 5,000 μm from the gingival margin, and at 100, 750 and 1,300 μm from the axial wall (Figure 2). The larger diagonal length of indentation was measured with a monitor (9M 100A Teli, Tokyo 140, Japan) and the values transformed to Knoop Hardness Numbers (KHN).

The microhardness means for each depth and experimental group was calculated and submitted to the ANOVA split-plot and Tukey's test that was used to compare Knoop microhardness among groups, depths and resin composites.

RESULTS

Microleakage Test

None of the groups showed complete prevention of dye penetration. The results of the statistical analysis are summarized in Table 1.

Analyzing the data, the SureFil (Dentsply/Caulk) "packable" resin composite showed better results when using the Conventional technique. The SS1 and SS2 techniques presented intermediate results, although they showed no statistical differences from PAC, which demonstrated the worst scores. The Conventional technique for polymer-

ization provided a similar resin-tooth interfacial seal to that of Soft-Start (Variable Intensity Polymerization, BISCO Inc) and a better seal when compared to Plasma Arc Curing (PAC, APOLLO 95E Elite, DMD Corp).

For Filtek Z250 (3M Dental Products) resin composite, there was no significant difference in leakage among the different methods of polymerization.

Knoop Microhardness Analysis

No significant differences in microhardness were observed between the resin composites ($p=0.1701$) and the C, SS1, SS2 and PAC unit polymerization techniques ($p=0.7103$).

The results showed no significant interaction among the resin composites vs light units ($p=0.9111$), resin composites vs depth ($p=0.3511$), light units vs depth ($p=0.2646$) and light units vs resin composite vs depth ($p=0.4173$) in microhardness values.

The Tukey's test ($p<0.01$) revealed significant differences in microhardness in relation to depth/thickness of resin. Hardness at the top surface (5,000 μm) was significantly higher, followed by the middle (2,500 μm) and bottom (100 μm) surface, which showed lower KHN means (Table 2). These findings were similar for both resins and curing techniques.

Table 1: Results of Microleakage Evaluation

Groups	Medium Ranks
G5. Z250/Conventional	55.4737 a
G6. Z250/SS1	55.4737 a
G1. SureFil/Conventional	63.1316 ab
G7. Z250/SS2	70.0253 abc
G8. Z250/PAC	81.6579 abcd
G2. SureFil/SS1	87.6316 bcd
G3. SureFil/SS2	96.8947 cd
G4. SureFil/PAC	101.7105 d

Kruskal-Wallis test: Significant difference ($p<0.05$)
Same letters were not statistically different

Table 2: Means and Standard Deviations Knoop Hardness Number (KHN) for the Different Cure Modes, Resin Composite and Depth

Resin Composite	Cure Mode	Depth					
		Bottom (100 μm)		Medium (2,500 μm)		Top (5,000 μm)	
		Mean	SD	mean	SD	mean	SD
SureFil	C	100.06	25.44	107.45	13.59	112.82	11.36
SureFil	SS1	103.69	13.46	112.30	8.66	109.04	11.12
SureFil	SS2	95.94	16.12	100.54	20.73	109.13	11.76
SureFil	PAC	95.20	20.76	100.43	21.0	120.20	10.33
Z250	C	99.15	15.08	100.73	16.21	100.67	13.06
Z250	SS1	94.23	22.42	108.75	26.46	109.20	18.85
Z250	SS2	96.44	15.03	104.04	7.89	105.97	12.11
Z250	PAC	97.65	16.46	99.80	19.25	105.80	13.82
Mean		97.80 C		104.27 B		109.1A	

Tukey's test ($p<0.05$), indicates statistical difference for means followed by distinct letters

DISCUSSION

Some techniques for reducing shrinkage stress and, consequently, marginal leakage have been suggested (Kays, Sneed & Nuckles, 1991). These include using reflective wedges (Lutz, Krejci & Barbakow, 1992), incremental restorative techniques (Tjan, Bergh & Lidner, 1992; Applequist & Meiers, 1996) and variations in light intensity (Uno & Asmussen, 1991; Feilzer & others, 1995; Unterbrink & Muessner, 1995). A lining material with a low-modulus of elasticity, such as a glass ionomer (Aboushala, Kugel & Hurley, 1996), a new generation of dentin bonding (Goracci, Mori & Bazzucchi, 1995; Nakabayashi & Saimi, 1996) or a flowable composite lining has also been proposed by some authors, mainly in association with the "packable" resin composite (Ferdianakis, 1998; Chuang, Liu & Jin, 2001).

The influence of using different kinds of light units with varying intensities during polymerization to reduce microleakage was evaluated in this study using a "packable" and a microhybrid resin composite.

None of the methods or restorative materials eliminate microleakage in the face of thermal changes and differences in the coefficient of thermal expansion between dental tissues and the restorative material. These results were also observed in other studies (Lieberman, Gorfil & Ben-Amar, 1996; Pimenta, 1999).

Both resins behaved differently when subjected to the same polymerization technique. While the microhybrid presented statistically similar results for all methods, the "packable" did not. In association with PAC units (G4) and SS2 (G3), the "packable" was statistically different in relation to C (G1) and SS1 (G2). The "packable" presented a high elasticity modulus that can cause more strain in the interface during polymerization (Davidson & others, 1984). Another reason may be that the "packable" composite may not adapt well to the dentin bonding agent and cavity preparation walls (Meiers, Kazemi & Meier, 2001).

The high microleakage scores that were found when the "packable" was compared to the microhybrid might indicate that the filler particle technology of the "packable" composite could translate into increased post-gel linear shrinkage stress directed at the margins (Meiers & others, 2001). Stress arising from post-gel polymerization shrinkage may produce defects in the composite-tooth bond, leading to bond failure and, consequently, post-operative sensitivity, microleakage and recurrent caries (Yap, Soh & Siow, 2002; Meiers & others, 2001). The more satisfactory results found for the microhybrid resin when compared with the "packable" in this study could be explained by the lower post-gel shrinkage as revealed by the manufacturers.

Different studies have indicated that Soft-Start (Variable Intensity Polymerization, BISCO Inc) light curing units can be used to improve marginal integrity

and decrease marginal gap (Uno & Asmussen, 1991; Goracci & others, 1996). However, according to the results of this study, less leakage was not observed when the Soft-Start technique (Variable Intensity Polymerization, BISCO Inc) was used compared to Conventional and Plasma Arc (PAC, APOLLO 95E Elite, DMD Corp). Other studies also reported these results (Sahafi, Peutzfeldt & Asmussen, 2001; Yap & others, 2002; Yap, Ng & Siow, 2001). For both pre-polymerizations, starting with 75 mW/cm² (G2 e G6) or 170 mW/cm² (G3 e G7), the groups presented no statistical differences between the resins. However, the association of the "packable" with SS2 (G3) was not similar to SS1 with the microhybrid resin (G6).

The "packable" resin composite cured with Plasma Arc (PAC, APOLLO 95E Elite, DMD Corp) curing showed the highest leakage scores. However, it was not statistically different from Plasma Arc (PAC, APOLLO 95E Elite, DMD Corp) with the microhybrid (G8), which behaved similarly with all techniques. Several studies have shown that high and fast curing rates tend to produce excessive polymerization stresses on adhesive bonds, resulting in poor marginal adaptation along gingival or dentinal margins (Brackett & others, 2000; Uno & Asmussen, 1991; Mehl & others 1997). This study's results seem to show that the low flow capacity of "packable" resin composite might be responsible for these values.

In this study, the microhardness of resin composite was measured in different depths as an indirect method for evaluating the relative degree of conversion (Mehl & others, 1997). The effective cure of resin composite is vital, not only to ensure optimum physical-mechanical properties (Asmussen, 1982), but also to ensure that clinical problems do not arise due to cytotoxicity of inadequately polymerized material (Caughman & others, 1991). In general, higher hardness values are an indication of more extensive polymerization (Helvatjoglou-Antoniadi & others, 1991).

According to the results, the resin composites SureFil (Dentsply/Caulk) and Filtek Z250 (3M Dental Products) presented similarly when the C, SS1, SS2 and PAC unit polymerization techniques were used.

There was a significant difference in depth among the bottom (100 µm), middle (2,500 µm) and top (5,000 µm) surfaces. For all techniques, microhardness was higher at the top surface. This can probably be explained as a result of the relationship between irradiation distance and effectiveness of polymerization (Pires & others, 1993). The depth of cure was reduced by increasing the distance between the light tip and composite surface (Hansen & Asmussen, 1997). The degree to which light activated composite polymerizes is proportional to the amount of light to which the material is exposed (Rueggeberg, Caughman & Curtis, 1994). The top surface of the

material was nearer to the light force than the subsequent resin composite layers; in this way, light transmission did not suffer any interference and the intensity was not reduced. However, at the middle and bottom surfaces the light intensity was greatly reduced due to light scattering, thus, decreasing the effectiveness of polymerization (Ruyter & Oysa, 1982). One way to compensate for this is to increase the light exposure time, which can provide better hardness results (Ota & others, 1985; Yap & others, 2001).

Although some studies demonstrated that three seconds of curing time was insufficient for optimal curing of composites when the Plasma Arc (PAC, APOLLO 95E Elite, DMD Corp) technique was used (Park & others, 2002), the results found in this study showed similarities among C, SS1 and SS2 for the microhybrid resin composite.

Despite the great advances in light units that present new polymerization techniques, the conventional method is still preferred. Providing adequate polymerization and satisfactory infiltration scores, the Conventional method may be similar to Soft-Start (Variable Intensity Polymerization, BISCO Inc) and better than PAC, although each material had different characteristics.

CONCLUSIONS

The results of this study allow the authors to conclude:

1. None of the techniques could eliminate microleakage;
2. For Filtek Z250 (3M Dental Products) microhybrid resin composite, all the polymerization techniques showed similar leakage results;
3. For SureFil (Dentsply/Caulk) "packable" resin composite, only the Soft-Start polymerization technique (SS1) (Variable Intensity Polymerization, BISCO Inc) with a 10-second initial intensity of 75mW/cm², followed by 30 seconds at 515mW/cm², decreased microleakage to levels similar to the Conventional technique;
4. All polymerization techniques presented similar results in microhardness values, but the top surface always presented high values followed by the middle and bottom surfaces.

Acknowledgements

The authors thank 3M (Brazil) and Dentsply (Brazil) for supplying the materials used in this study.

(Received 7 May 2002)

References

- Aboushala A, Kugel G & Hurley E (1996) Class II composite resin restorations using glass-ionomer liners: Microleakage studies *Journal of Clinical Pediatric Dentistry* 21(1) 67-70.
- Appelquist EA & Meiers JC (1996) Effect of bulk insertion, pre-polymerized resin composite balls, and beta-quartz inserts on microleakage of Class V resin composite restorations *Quintessence International* 27(4) 253-258.
- Asmussen E (1982) Restorative resins: Hardness and strength vs quantity of remaining double bonds *Scandinavian Journal of Dental Research* 90(6) 484-489.
- Bayne SC, Heymann HO & Swift EJ Jr (1994) Update on dental composite restoration *Journal of the American Dental Association* 125(6) 687-701.
- Brackett WW, Haisch LD & Covey DA (2000) Effect of plasma arc curing on the microleakage of Class V resin-based composite restorations *American Journal of Dentistry* 13(3) 121-122.
- Carvalho RM, Pereira JC, Yoshiyama M & Pashley DH (1996) A review of polymerization contraction: The influence of stress development versus stress relief *Operative Dentistry* 21(1) 17-24.
- Caughman WF, Caughman GB, Shifflett RA, Rueggeberg F & Schuster GS (1991) Correlation of cytotoxicity, filler loading and curing time of dental composites *Biomaterials* 12(8) 737-740.
- Chuang S-F, Liu J-K & Jin Y-T (2001) Microleakage and internal voids in Class II composite restorations with flowable composite linings *Operative Dentistry* 26(2) 193-200.
- Davidson CL, de Gee AJ & Feilzer A (1984) The competition between the composite-dentin bond strength and the polymerization contraction stress *Journal of Dental Research* 63(12) 1396-1399.
- de Castro AK, Hara AT & Pimenta LA (2000) Influence of collagen removal on shear bond strength of one-bottle adhesive systems in dentin *Journal of Adhesive Dentistry* 2(4) 271-277.
- Donly KJ, Jensen ME, Reinhardt J & Walker JD (1987) Posterior composite polymerization shrinkage in primary teeth: An *in vitro* comparison of three restorative techniques *Pediatric Dentistry* 9(1) 22-25.
- Eick JD & Welch FH (1986) Polymerization shrinkage of posterior composite resin and its possible influence on postoperative sensitivity *Quintessence International* 17(2) 103-111.
- Feilzer AJ, Dooren LH, de Gee AJ & Davidson CL (1995) Influence of light intensity on polymerization shrinkage and integrity of restoration-cavity interface *European Journal of Oral Science* 103(5) 322-326.
- Ferdianakis K (1998) Microleakage reduction from newer esthetic restorative materials in permanent molars *Journal of Clinical Pediatric Dentistry* 22(3) 221-229.
- Gallo JR, Comeaux R, Haines B, Xu X & Burgess JO (2001) Shear bond strength of four filled dentin bonding systems *Operative Dentistry* 26(1) 44-47.
- Goracci G, Mori G & Bazzocchi M (1995) Marginal seal and biocompatibility of a fourth-generation bonding agent *Dental Materials* 11(6) 343-347.
- Goracci G, Mori G & Casa de'Martinis L (1996) Curing light intensity and marginal leakage of resin composite restorations *Quintessence International* 27(5) 355-362.

- Hansen EK & Asmussen E (1997) Visible-light curing units: Correlation between depth of cure and distance between exit window and resin surface *Acta Odontologica Scandinavica* 55(3) 162-166.
- Helvatjoglou-Antonietti M, Papadogiannis Y, Koliniotou-Kubia E & Kubias S (1991) Surface hardness of light-cured and self-cured composite resins *Journal of Prosthetic Dentistry* 65(2) 215-220.
- Kays BT, Sneed WD & Nuckles DB (1991) Microhardness of Class II composite resin restorations with different matrices and light positions *Journal of Prosthetic Dentistry* 65(4) 487-490.
- Kidd EA (1976) Microleakage: A review *Journal of Dentistry* 4(5) 199-206.
- Leinfelder KF (1995) Posterior composite resin: The material and their clinical performance *Journal of the American Dental Association* 126(5) 663-664, 667-668, 671-672.
- Lieberman R, Gorfil C & Ben-Amar A (1996) Reduction of microleakage in Class II composite resin restoration using retentive pins *Journal of Oral Rehabilitation* 23(4) 240-243.
- Lutz F, Krejci I & Barbakow F (1992) Restoration quality in relation to wedge-mediated light channeling *Quintessence International* 23(11) 763-767.
- Mandras RS, Retief DH & Russel CM (1991) The effects of thermal and occlusal stresses on the microleakage of the Scotchbond 2 dentinal bonding system *Dental Materials* 7(1) 63-67.
- Mehl A, Hickel R & Kunzelmann KH (1997) Physical properties and gap formation of light-cured composites with and without "softstart-polymerization" *Journal of Dentistry* 25(3-4) 321-330.
- Meiers JC, Kazemi R & Meier CD (2001) Microleakage of packable composite resins *Operative Dentistry* 26(2) 121-126.
- Nakabayashi N & Saimi Y (1996) Bonding to intact dentin *Journal of Dental Research* 75(9) 1706-1715.
- Opdam NJ, Roeters FJ, Feilzer AJ & Verdonchot EH (1998) Marginal integrity and post-operative sensitivity in Class II resin composite restoration *in vivo* *Journal of Dentistry* 26(7) 555-562.
- Ota K, Kikuchi S, Kopel HM, Thanos CE & Nakamura RM (1985) Effect of light exposure time on the depth of curing in various composite resin systems *Pediatric Dentistry* 7(1) 19-22.
- Park SH, Krejci I & Lutz F (2002) Microhardness of resin composites polymerized by plasma arc or conventional visible light curing *Operative Dentistry* 27(1) 30-37.
- Peutzfeldt A, Sahafi A & Asmussen E (2000) Characterization of resin composites polymerized with plasma arc curing units *Dental Materials* 16(5) 330-336.
- Pimenta LAF (1999) [Avaliação da microinfiltração em restaurações de classe II em compósito realizadas com duas técnicas diferentes de inserção] Piracicaba 94p [Tese (Livre Docência)-FOP-UNICAMP].
- Pires JA, Cvitko E, Denehy GE & Swift EJ Jr (1993) Effects of curing tip distance on light intensity and composite resin: microhardness *Quintessence International* 24(7) 517-521.
- Rueggeberg FA, Caughman WF & Curtis JW Jr (1994) Effect of light intensity and exposure duration on cure of resin composite *Operative Dentistry* 19(1) 26-32.
- Ruyter IE & Oysaed H (1982) Conversion in different depths of ultraviolet and visible light activated composite materials *Acta Odontologica Scandinavica* 40(3) 179-192.
- Sahafi A, Peutzfeldt A & Asmussen E (2001) Soft-Start polymerization and marginal gap formation *in vitro* *American Journal of Dentistry* 14(3) 145-147.
- Silikas N, Eliades G & Watts DC (2000) Light intensity effects on resin composite degree of conversion and shrinkage strain *Dental Materials* 16(4) 292-296.
- Tjan AH, Bergh BH & Lidner C (1992) Effect of various incremental techniques on the marginal adaptation of Class II composite resin restorations *Journal of Prosthetic Dentistry* 67(1) 62-66.
- Uno S & Asmussen E (1991) Marginal adaptation of a restorative resin polymerized at reduced rate *Scandinavian Journal of Dental Research* 99(5) 440-444.
- Unterbrink GL & Muessner R (1995) Influence of light intensity on two restorative systems *Journal of Dentistry* 23(3) 183-189.
- Yap AU, Ng SC & Siow KS (2001) Soft-Start polymerization: Influence on effectiveness of cure and post-gel shrinkage *Operative Dentistry* 26(3) 260-266.
- Yap AU, Soh MS & Siow KS (2002) Post gel shrinkage with pulse activation and soft-start polymerization *Operative Dentistry* 27(1) 81-87.

Anexo 4: Comprovante de recebimento do artigo "Microleakage evaluation of composite resins restorations polymerized with different blue light-emitting diode units (LEDs)" para avaliação.

Quintessence International

Editor-in-Chief: Thomas G. Wilson, Jr, DDS

June 7, 2002

Professor Luiz André Freire Pimenta
School of Dentistry of Piracicaba - UNICAMP
Restorative Dentistry
Av. Limeira, 901-Areião
Caixa Postal 32
Piracicaba-SP, Brazil
CEP: 13414-018

Dear Dr Pimenta:

Thank you for submitting the manuscript "Microleakage evaluation of composite resins restorations polymerized with different blue light-emitting diode units (LEDs)." Your submission included:

- 1 manuscript (+2 copies)
- 3 tables (+2 duplicate sets)
- 1 disk
- 1 mandatory submission form

Your manuscript is being forwarded to the QI Editor-in-Chief, who will enter it into the review process. Because of the increased number of submissions we are receiving at this time, the review process will take at least 12 weeks. Quintessence Publishing understands that this is a lengthy amount of time, and we sincerely appreciate your patience.

The number assigned to this manuscript is 01708. Please use this number on all future correspondence concerning this article. To receive immediate attention regarding the status of your paper, all future prepublication correspondence should be addressed to:

Ms. Robin Baumgartner, Editorial Coordinator
Quintessence International
5465 Blair Road, Suite 200
Dallas, TX 75231-4100
972.247.5094
robinworld@earthlink.net

Thank you once again for considering *Quintessence International*. We look forward to working with you.

Sincerely,

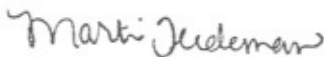

Marti A. Tiedeman
Assistant Editor
log# 01708



Publisher: Quintessence Publishing Co, Inc, 551 Kimberly Drive, Carol Stream, Illinois 60188-1881
Telephone: (630) 682-3223 • Toll-Free: (800) 621-0387 • Fax: (630) 682-3288
E-mail: service@quintpub.com • Website: www.quintpub.com

Anexo 5: Comprovante de recebimento do artigo "*Influence of different polymerization techniques on adhesion of resin composite restorations*" para avaliação.

This message is not flagged. [Flag Message - Mark as Unread]

From: "Journal of Operative Dentistry Editor" <editor@jopdent.org> | This is Spam | Add to Address Book
To: "Cristiane Mariote" <crismariote@yahoo.com>
Subject: RE: Manuscript
Date: Tue, 28 Jan 2003 19:20:49 -0500

The manuscript was received, sent to the reviewers and returned to the editor yesterday. You should be hearing from him shortly.

Joan Matis
Editorial Assistant/Subscription Manager
Operative Dentistry
email: jpmatis@indy.rr.com
fax: USA 317-852-3162

-----Original Message-----

From: Cristiane Mariote [mailto:crismariote@yahoo.com]
Sent: Tuesday, January 28, 2003 5:30 PM
To: editor@jopdent.org
Subject: Manuscript

I would like to know if the manuscript " Influence of different polymerization techniques on adhesion of resin composite restorations" was received. The authors are AMARAL, C.M.; PERIS, A.R.; AMBROSANO, G.M.B.; PIMENTA, L.A.F. The manuscript was dispatched at October 23, 2002. Please, reply to me as soon as possible.

Sincerely,
Cristiane Mariote Amaral

