

UDC 621.382.3 (045)

¹O. S. Melnyk
²Y. V. Poliakov
³A. O. Kosov

COMPUTER SIMULATION OF CHARACTERISTICS SINGLE-ELECTRON TRANSISTORS

Educational & Research Institute of Air Navigation, Nation Aviation University, Kyiv, Ukraine
 E-mails: ¹melnyk.ols@gmail.com, ²ibex@ukr.net, ³aaaassssssddddd@i.ua

Abstract—Proposed methods of modeling of electrical and temperature characteristics of single-electron transistor for providing information to system of computer-aided design Electronics Workbench. Analyzed dependence in current-voltage characteristics of nano-device through values of temperature and operating mode.

Index Terms—Single-electron transistor, modeling, volt-ampere characteristics.

I. INTRODUCTION

Single-electron nano-devices are modern and perspective elemental base for large scale integral circuits, because they provide ultralow power consumption and up high operating frequency range (up to 10 THz) for new functional nanoelectronic devices. Such devices have one or few sub low regions of conduction, which have extremely low capacity. Due to high resulting charging energy of this area, electrical charge within it becomes quantized, this means that by creating certain electrical fields we can induce or terminate tunneling of electrons in quantum dots or otherwise. Such effect, that been called Coulomb blockade, has been used for managing extra low streams of electrons through out single-electron nanotransistor.

Single-electron transistor (SET) – is basic element of single-electron circuits. It has only one area of conduction, that connected with source and drain electrodes through tunnel junctions. That area is called Coulomb Island that has electrostatic connection with one or two of gate electrodes.

In blocked state there are no available energy levels inside tunnel area on source contact. All energy levels on island electrode with lesser energies are filled with electrons. Energy levels of island are decreasing when positive voltage being applied to gate electrode. Electron can be tunneled on island or into vacant energy level and from there to drain electrode, reaching level of Fermi on it.

By periodically changing voltage on SET gate, because recurring Coulomb blockade effect, there is a probability of stepped current modulation, which is passing from source to drain. Furthermore, in single-electron devices that possess few areas with mutual capacitive link, it becomes possible for transition of certain single electrons through those areas. As follows, it is possible to implement totally new logical circuits based on single-electron devices that designed to operate with individual electrons.

II. PROBLEM STATEMENT

It is necessary to simulate voltage-current characteristics of SET. At the beginning, we should apply electronic model in form of equivalent electrical circuit of SET (Fig. 1b), which has been implemented into database of computer aided design program – Electronics Workbench.

Based on schematic of single-electron transistor (Fig. 1a) $U_{g,s,d}$, $R_{g,s,d}$, $C_{g,s,d}$, in accordance, are potentials, tunnel (quantum) resistances and capacities of gate, source and drain. On equivalent circuit of SET (Fig. 1, b): U_g is the control voltage on gate, U_{sd} is the power supply voltage of source-drain, $C_{gd} = C_{gs} = 1.6$ aF, $C_{sd} = 3.2$ aF, are capacity gate-drain, gate-source and source-drain accordingly; R_g is the resistance of gate, $R_{1,2,3}$ is the equivalent quantum resistances in-between source and drain, diodes VD_1, VD_2 and additional power sources $E_1 = 20$ mV and $E_2 = -20$ mV are modeling effects of Coulomb blockade in normal and inverse modes.

III. PROBLEM SOLUTION

In nonlinear model of SET, resistance of R_1, R_2, R_3 resistors that has a dependency from input voltage U_g on gate is considered to be approximated as following functions:

$$R_1(U_g) = R_{11} + R_{12} \cdot \cos\left(\pi \frac{U_g}{U_T} + k_1\right), \quad (1)$$

$$R_2(U_g) = R_3(V_g) = \frac{R_{23}R_1(U_g)}{R_1(U_g)k_2 - R_{23}}, \quad (2)$$

where R_{11}, R_{12}, R_{13} are resistance parameters of model configuration; $U_T = \frac{kT}{q} = \frac{T}{11600}$ is the

thermodynamic potential, that with temperature value of $T = 297$ K is equal to 25 mV; k_1 and k_2 are approximation coefficients (Fig. 2).

Temperature-related parameters of tuning are changing by these laws:

$$R_{11}(T) = R_{11}(T_0) + R_{2T} \exp(-0.09T),$$

$$R_{12}(T) = R_{2T} \exp(-0.09T),$$

$$R_{23}(T) = R_{23}(T_0) + R_{3T}T,$$

where T is the temperature, parameters of approximation have next values: $R_{11}(T_0) = 11.8$ GOhm; $R_{23}(T_0) = 0.2$ nOhm; $R_{2T} = 3$ GOhm and $R_{3T} = 0.05$ nOhm.

A temperature dependency of resistant parameters has been represented on Fig. 3.

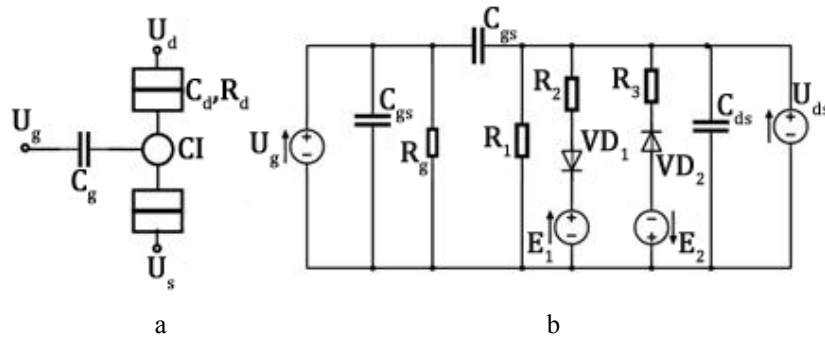

Fig. 1. Model of single-electron transistor with following parameters: $C_{gs} = 3.2$ aF, $C_{ds} = C_{gd} = 1.6$ aF, $R_g = 100$ MOhm (a), and equivalent electrical circuit for its model (b), CI is the Coulomb Island

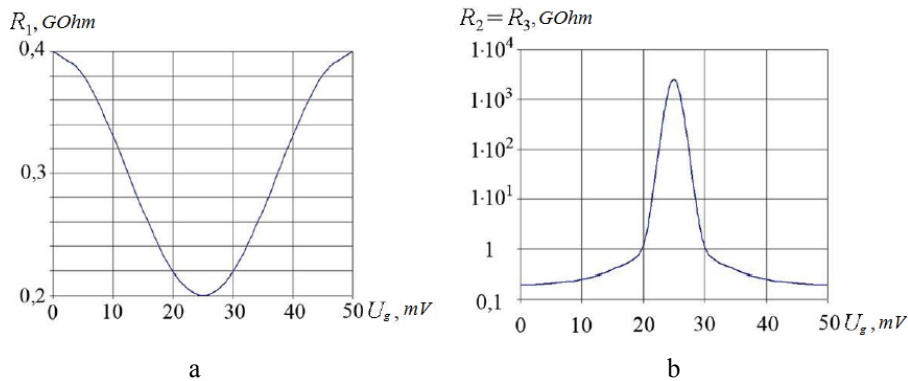

Fig. 2. Dependence graphs of resistances R_1 (a), R_2 and R_3 (b) from gate voltage U_g plot data has been calculated by using equations (1) and (2)

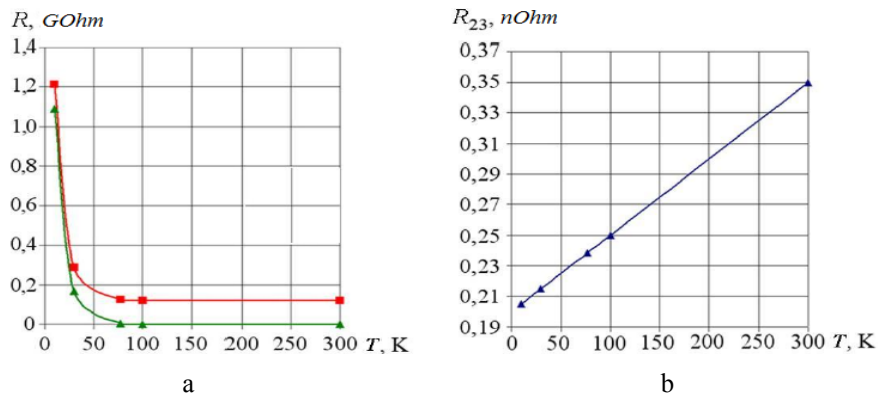

Fig. 3. Dependence of resistant tuning parameters R_{11} , R_{12} (a) and R_{23} (b) from temperature:

—■— is the R_{11} ; —▲— is R_{12}

By using system of computer-aided design Electronics Workbench let's simulate volt-ampere characteristics of SET, thus by fixating the voltage

on gate and changing voltage of source-drain we will register values of source current (Fig. 4).

Obviously that within values more than 10 mV on gate voltage, Coulomb blockade begins to disappear and with value of $U_g = 25$ mV – completely vanishes.

Let's analyze behavior of volt-ampere characteristics with changing temperature and zero voltage on gate ($U_g = 0$).

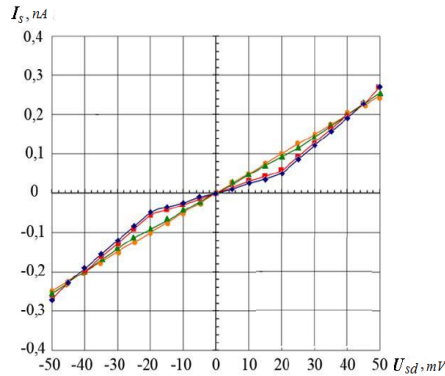

Fig. 4. Simulation of volt-ampere characteristics of SET, build with different values of gate voltage $C_{gs} = 3.2$ aF,

$C_{ds} = C_{gd} = 1.6$ aF, $R_g = 100$ MOhm, $T = 30$ K :

—◆— is the $U_g = 0$ mV; —■— is the $U_g = 10$ mV;
—▲— is the $U_g = 20$ mV; —●— is the $U_g = 25$ mV

IV. CONCLUSION

By analyzing of the results simulation volt-ampere characteristics of single-electron transistor, which have been build with software Electronics Workbench in different terms, has been defined that volt-ampere characteristics of single-electron transistor are mostly dependent on two parameters – gate voltage and temperature:

– within values of gate voltage that are greater than 10 mV, Coulomb blockade begins to decrease, and with $U_g = 25$ mV completely vanishes, that concludes in straight volt-ampere characteristics;

As follows from Fig. 5, within temperature values greater than 30 K, Coulomb blockade begins to vanish, and with temperature value of $T = 100$ K is completely gone. Calculated volt-ampere characteristics models of SET are almost comparable with experimental data that been described in following research [1], [2].

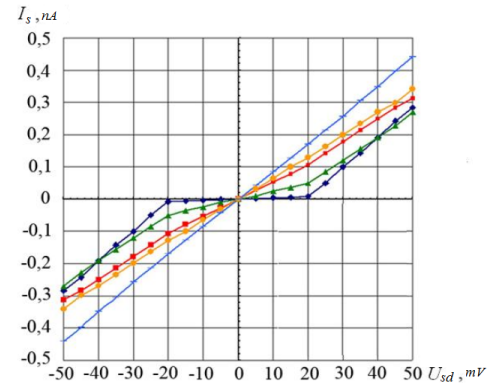

Fig. 5. Volt-ampere characteristics of single-electron transistor, build with different temperature values:

—◆— is the $T = 10$ K; —▲— is the $T = 30$ K; —■— is the $T = 77$ K; —●— is the $T = 100$ K;
—▼— is the $T = 300$ K

– with temperature values greater than 30 K, Coulomb blockade begins to decrease and towards temperature of $T = 100$ K – completely gone.

REFERENCES

- [1] S. W. Hwang, KOSEC developed at Nanoelectronics Laboratory in Korea University. Seoul, Korea, 2008. 825 p.
- [2] Y. S. Yu, “Modeling of Single-Electron Transistors for Efficient Circuit and Design.” *IEEE Trans. Electron. Devices*. 1999, no. 7, pp. 1667–1682.

Received January 21, 2017

Melnyk Oleksandr. Candidate of Sciences (Engineering). Associate Professor.

Electronics Department, Educational & Research Institute of Air Navigation, National Aviation University, Kyiv, Ukraine. Education: Kiev Polytechnic Institute, Kyiv, Ukraine (1971).

Research area: Nanoelectronics, Computer aided design of nanoelectronic circuits, Simulation of single-electron circuit.

Publications: 176.

E-mail: melnyk.ols@gmail.com

Poliakov Yevhen. Student.

Electronics Department, Educational & Research Institute of Air Navigation, National Aviation University, Kyiv, Ukraine. Education: National Aviation University, Kyiv, Ukraine.

Research area: Modeling of single-electron circuits.

Publications: 1.

E-mail: ibex@ukr.net

Kosov Anton. Student.

Electronics Department, Educational & Research Institute of Air Navigation, National Aviation University, Kyiv, Ukraine. Education: National Aviation University, Kyiv, Ukraine.

Research area: Modeling of single-electron circuits.

Publications: 1.

E-mail: aaaasssssdddddd@i.ua

О. С. Мельник, Є. В. Поляков, А.О. Косов. Комп'ютерне моделювання характеристик одноелектронних транзисторів

Розроблено методи моделювання електричних та температурних характеристик одноелектронного транзистора для інформаційного забезпечення системи автоматизованого схемотехнічного проектування Electronics Workbench. Проаналізовано залежність вольт-амперних характеристик наноприладу від впливу температури та робочого режиму.

Ключові слова: одноелектронні транзистори; моделювання; вольт-амперні характеристики.

Мельник Олександр Степанович. Кандидат технічних наук. Доцент.

Кафедра електроніки, Національний авіаційний університет, Київ, Україна.

Освіта: Київський політехнічний інститут, Київ, Україна (1971).

Напрямок наукової діяльності: наноелектроніка, автоматизовані системи проектування, моделювання одноелектронних схем.

Кількість публікацій: 176.

E-mail: melnyk.ols@gmail.com

Поляков Євген Володимирович. Студент.

Кафедра електроніки, Національний авіаційний університет, Київ, Україна.

Освіта: Національний авіаційний університет, Київ, Україна.

Напрямок наукової діяльності: моделювання одноелектронних схем.

Кількість публікацій: 1.

E-mail: ibex@ukr.net

Косов Антон Олегович. Студент.

Кафедра електроніки, Національний авіаційний університет, Київ, Україна

Освіта: Національний авіаційний університет, Київ, Україна.

Напрямок наукової діяльності: моделювання одноелектронних схем.

Кількість публікацій: 1.

E-mail: aaaasssssdddddd@i.ua

А. С. Мельник, Е. В. Поляков, А. О. Косов. Компьютерное моделирование характеристик одноэлектронных транзисторов

Разработаны методы моделирования электрических и температурных характеристик одноэлектронного транзистора для информационного обеспечения системы автоматизированного схемотехнического проектирования Electronics Workbench. Проанализирована зависимость вольт-амперных характеристик наноприбора от влияния температуры и рабочего режима.

Ключевые слова: одноэлектронные транзисторы; моделирование; вольт-амперные характеристики.

Мельник Александр Степанович. Кандидат технических наук. Доцент.

Кафедра электроники, Национальный авиационный университет, Киев, Украина.

Образование: Киевский политехнический институт Киев, Украина (1971).

Направление научной деятельности: нанoeлектроника, автоматизированные системы проектирования, моделирование одноэлектронных схем.

Количество публикаций: 176.

E-mail: melnyk.ols@gmail.com

Поляков Евгений Владимирович. Студент.

Кафедра электроники, Национальный авиационный университет, Киев, Украина.

Образование: Национальный авиационный университет, Киев, Украина.

Направление научной деятельности: моделирование одноэлектронных схем.

Количество публикаций: 1.

E-mail: ibex@ukr.net

Косов Антон Олегович. Студент.

Кафедра электроники, Национальный авиационный университет, Киев, Украина.

Образование: Национальный авиационный университет, Киев, Украина.

Направление научной деятельности: моделирование одноэлектронных схем.

Количество публикаций: 1.

E-mail: aaaasssssdddddd@i.ua