



# Graphene MEMS capacitive microphone: highlight and future perspective

Rahmat Zaki Auliya HM<sup>a\*</sup>, Mohd Anuar Md Ali<sup>a</sup>, Mohd Syakirin Rusdi<sup>a</sup>

<sup>a</sup>Institute of Microengineering and Nanoelectronics, Universiti Kebangsaan Malaysia, Bangi, Selangor, 43600, Malaysia

## Abstract

MEMS microphone is widely used in the electronic product nowadays because of its tiny size body, low power consumption and performance consistency over time and temperature. This paper highlights on the MEMS capacitive microphone and future perspective. This paper discusses the working principle of capacitive-based MEMS microphone and some of the important performance parameter that must be considered for the MEMS microphone. Recent MEMS microphone technology incorporates graphene as the microphone membrane. Finally, we discuss the future prospect and the possibility for graphene usage as the membrane for MEMS microphone.

*Keywords:* capacitive microphone, diaphragm, graphene, MEMS microphone

Received 12 March 2016; Accepted 03 October 2016

## 1. Introduction

Microphone is a transducer that converts sound pressure into electrical signal by assistance of a membrane [1,2]. Microphone is widely used for telecommunication equipment, musical instrument or sound detector such as telephone, radio, voice recorder, theatre, and ultrasonic detector. Microphone receives sound wave from outside and code it into electrical signal before preamplifier processing. For human necessity, microphone has to be able covering human audible range, 20 Hz- 20 kHz. Even though, recent microphone technology can receive ultrasonic frequency, which can detect animal sound. Various types of different microphones can be categorized according to the principle used for conversion of the acoustic fields to the electrical signal, which are Condenser microphone (or so-called capacitive-based), Electro-dynamic microphone and Piezoelectric microphone [2,3]. Development of MEMS technologies for integrated circuits (IC) has also emerging for development of capacitive-based MEMS microphone technology [4,5,6].

Membrane is the fundamental key of microphone performance. When sound wave hit the membrane, it will be vibrated and form frequency response. Higher frequency of sound will generate faster vibration of membrane. The deflection of membrane is detecting using several methods, such as electromagnetic, piezoresistive and capacitive microphone. Capacitive-type microphone is commonly used in MEMS (Microelectronic and Mechanical System)

microphone due to its compatibility with fabrication technology.

MEMS microphone shows better sensitivity as well as small packaging. Its thin membrane can be in several micrometer sized. Flexibility and strength of membrane lead to the quality of microphone.

This review covers discussion regarding below themes.

- Working principle of capacitive-based MEMS microphone
- Performance parameter of MEMS microphone
- Current development Graphene based MEMS microphone
- Future perspective of MEMS microphone technology

## 2. Working Principle of Capacitive-Based Microphone

The most widely used microphone type today is the condenser-type microphone, sometimes also called electret microphones. In a condenser microphone, a metallic or conducting diaphragm is placed close to and parallel with a backplate (Fig. 1), so that the diaphragm and the backplate form a capacitor [2]. The capacity  $C_m$  of this capacitor is given by

$$C_m = \frac{\epsilon_0 \pi b^2}{h} \quad (1)$$

where  $\epsilon_0$  is the dielectric constant for air,  $b$  is the radius of the backplate, and  $h$  is the equilibrium distance between

\* Corresponding author Tel.: N/A.

E-mail: [rahmatzaki@siswa.ukm.edu.my](mailto:rahmatzaki@siswa.ukm.edu.my)

DOI: 10.21752/sjppi-ukm/se/a03102016

the backplate and the diaphragm. This capacitor is charged by a voltage source  $V_c$  through a large series resistor  $R_c$  so that the charge  $Q_c$  on the microphone becomes

$$Q_c = C_m V_c = V_c \frac{\epsilon_0 \pi b^2}{h} \tag{2}$$

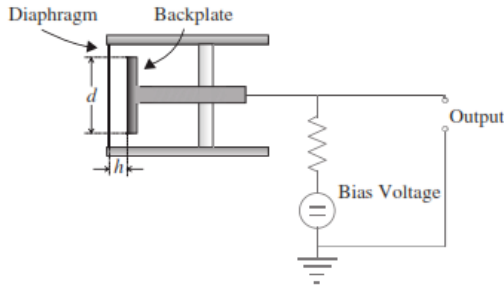

Fig. 1. Condenser microphone principle [2]

By the advantages of MEMS technology, it has been produced capacitive-type MEMS microphone that has similar concept to the condenser microphone described above. It detects sound by measuring its capacitance of two electrodes, vibrating electrode (diaphragm) and fixed electrode (backplate) as shown in Fig.2. Diaphragm has a thinner layer than backplate, because diaphragm has to deflect when sound wave is coming. These two electrodes are separated by an airgap to build a capacitance value. Also, these two electrodes are connected by DC-biased voltage. Displacement of diaphragm would change the capacitance value between two electrodes and build electrical signal. Air inside the airgap will flow outside through cavity in backplate to reduce the air damping. There is a consideration to choose pull-in voltage to maintain two electrodes from stick together.

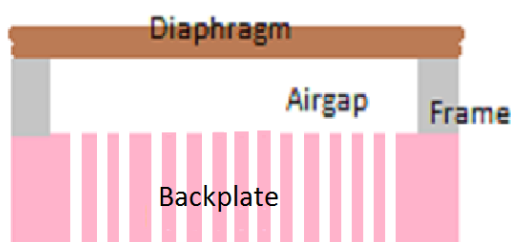

Fig. 2. MEMS Condenser Microphone

When sound wave comes to the surface, the diaphragm will be displaced from its equilibrium position. If the diaphragm is displaced by an amount  $x$ , this will, according to Eq. (1), cause a change in the microphone capacity:

$$C_{m,\Delta} = \frac{\epsilon_0 \pi b^2}{h+x} \tag{3}$$

The large series resistor  $R_c$  and a high input impedance preamplifier certifies that the charge  $Q_c$  in Eq. (2) is kept constant. The change in capacity will therefore result in a change in the voltage  $V_{out}$  across the microphone capacitor:

$$Q_c = C_m V_c = C_{m,\Delta} V_{out} = V_{out} \frac{\epsilon_0 \pi b^2}{h+x} \tag{4}$$

Combining eqs. (2) and (4) gives

$$V_{out} = V_c \frac{h+x}{h} \tag{5}$$

A pressure difference  $p$  between the inside and the outside of the microphone will give a resulting diaphragm force  $F$  given by

$$F = pA \tag{6}$$

where  $A$  is the effective diaphragm area. If  $Z_m$  is the mechanical impedance of the diaphragm, the resulting displacement of the diaphragm (Fig. 3) will be

$$x = \frac{F}{j\omega Z_m} = \frac{A}{j\omega Z_m} p \tag{7}$$

and the output signal from the microphone will be

$$V_{out} = V_c \frac{h+p(A/j\omega Z_m)}{h} \tag{8}$$

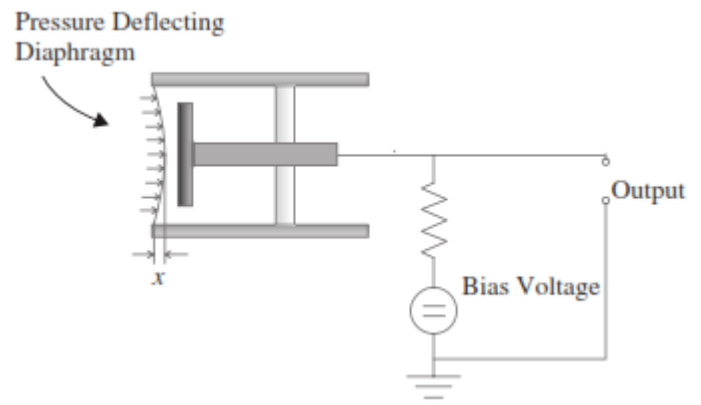

Fig. 3. Condenser microphone diaphragm deflection [2]

This equation shows that, for an overpressure outside the microphone, where the diaphragm is deflected toward the backplate (corresponding to a negative  $x$ ), the output signal will go down.

In general, the mechanical impedance of the diaphragm can be expressed as

$$Z_m = j\omega m_m + r_m + \frac{1}{j\omega C_m} \tag{9}$$

where  $m_m$  is the diaphragm mass,  $r_m$  is the damping in the microphone, and  $c_m$  is the stiffness of the diaphragm. It can

be seen from Eq. (8) that in order to obtain a flat frequency response, the mechanical impedance of the diaphragm must be controlled by the diaphragm stiffness, and the contributions from mass and damping must be negligible:

$$Z_m \approx \frac{1}{j\omega C_m} \quad (10)$$

And if this is substituted in Eq. (8), the microphone output as a function of the input pressure is given by

$$V_{out} = V_c \frac{h+pAC_m}{h} \quad (11)$$

In practice, the microphone capacity is loaded by lost capacitance and the input impedance of the preamplifier, and this will lead to non-ideal situations with limitations in performance and frequency range.

### 3. Performance Parameter

Performance is one of the most important aspects that must be considered for all electronics parts. Sensitivity, Dynamic range and Signal to Noise Ratio are the important performance indicator for MEMS microphone [7].

#### 3.1. Sensitivity

It is requirement for an ideal microphone including its measurement system to have an output voltage amplitude,  $E$  proportional with the acceleration amplitude,  $a$  (or exciting pressure amplitude,  $p$ ). Sensitivity,  $M_p$  is defined as the ratio of open-circuit output voltage to input pressure (or acceleration). Noise will exceed the voltage signal generated by the microphone in the case of noise measurements with very low sound pressure amplitudes. This situation will govern the lower signal amplitude limit for the measurements. Sound pressure that is too high will cause the displacement of the diaphragm become so large and with this the generated voltage is not proportional to the displacement. The upper amplitude use limit of the microphone will be set by the nonlinearity. The physical damage of the microphone can be occur when the sound pressure is above the nonlinear limit. For analog microphone the sensitivity is measured in  $mV_{RMS}/Pa$  or  $dBV/Pa$  and for digital microphone it is expressed in  $dBFS$ .

#### 3.2. Dynamic range

The difference of acoustic overload point and noise floor is called dynamic range. Good quality microphone should have the dynamic range in the range of about 100 to 120dB. The transducer sensitivity is normally increase when the microphone diaphragm diameter is increased. The problem of electrical noise is lesser and lower signal amplitude limit for measurements will be decreased when the diameter of the diaphragm is increased. However, a larger diaphragm diameter will reduce the upper sound pressure level limit (nonlinearity problem) and give larger

deflection for sound pressure. The usable operation range is between the upper and lower amplitude limits. Small diameter microphone is not so sensitive when we compared to the large diameter microphone. However, it can still be used for high-amplitude sound pressure without distortion but it has quite high noise floor. Differ from small diameter microphone, large diameter microphone is more sensitive, can be used for lower level noise and has lower noise floor but it has diffraction problems at lower frequencies. By considering dynamic range problems, large diameter microphone is suitable for intense noise and small-diameter microphone suits very quiet sound.

#### 3.3. Signal to Noise Ratio (SNR)

The signal-to-noise ratio specifies the ratio between a given desired (as the reference) signal to the amount of residual or background noise at the microphone output. The desired signal is measured at 94dB SPL (1Pa) @1kHz and the residual noise is the electrical output when the microphone is in silence. The SNR usually represented as specification A-weighted value (dBA) with a 20 kHz bandwidth. A-weighting is a presented SNR that includes correction factor corresponding to human ear's sensitivity to sound at different frequencies. Different microphone must be compared on the same weighting and bandwidth for SNR. It is inaccurate if different weighting and bandwidth are used for the measurement.

### 4. Graphene as MEMS Microphone Diaphragm

Acoustic performance of condenser microphone is derived mainly from the membrane's size and achievable static tension. The widely studied and available nickel has been the one of dominant membrane material for several decades. However, following recent development of graphene as promising material for various electronics devices, it has also been studied for MEMS microphone. In one of the study, a multilayer graphene membrane has been utilized for a condenser microphone. The graphene device outperforms a high end commercial nickel-based microphone over a significant part of the acoustic spectrum, with a larger than 10 dB enhancement of sensitivity. Their experimental results are supported with numerical simulations, which show that a 300 layer thick graphene membrane under maximum tension would offer excellent extension of the frequency range, up to 1 MHz, with similar sensitivity as commercial condenser microphones [8].

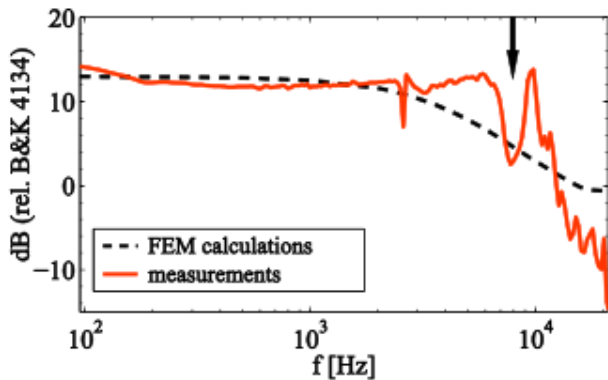

Fig. 4. Comparison of the measured graphene microphone response (30 layer graphene membrane, red curve) to the FEM calculated response (black dashed curve) [8]

Wireless communication requires for ultrasonic range transmitters and receivers, in the range of 20 kHz to 0.5 MHz. This is beyond human audible range which is between 20 to 20 kHz. For a MEMS microphone to have broad application both in human audible range and ultrasonic range, it needs for capability of wide frequency range. In a study a graphene-based wideband microphone has been developed, which is applicable for both range. It is shown that graphene-based acoustic transmitters and receivers have a wide bandwidth, from the audible region (20~20 kHz) to the ultrasonic region (20 kHz to at least 0.5 MHz). Using the graphene-based components, they reveal efficient high-fidelity information transmission using an ultrasonic band centred at 0.3 MHz. The graphene-based microphone is also shown to be capable of directly receiving ultrasound signals generated by bats in the field, and the ultrasonic radio, coupled to electromagnetic (EM) radio, is shown to function as a high-accuracy rangefinder. The ultrasonic radio could serve as a useful addition to wireless communication technology where the propagation of EM waves is difficult [9].

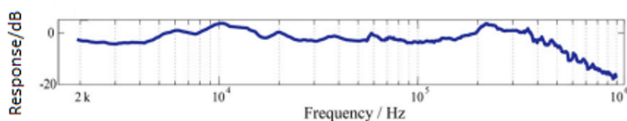

Fig. 5. Response including ultrasonic region. [9]

Because graphene has demonstrated advanced ability in enhancing performance of capacitive MEMS microphone in term of sensitivity and practical range, the material should be paid more attention in future studies. The potential performance improvement is huge.

## 5. Future Perspective of MEMS Microphone Technology

Future development of capacitive-based MEMS microphone shall put some consideration in the studies of bio-inspired device and graphene-based material.

### 5.2. Bio-inspired design device

Design of MEMS microphone inspired by biological structure is highly potential to eliminate the drawbacks of current technology. As example, MEMS microphone inspired by parasitoid fly, known as *Ormia ochracea* has been demonstrated [10,11,12]. In these works, sound localization sensor is realized by optimization of angular range of operation and directional sensitivity of the microphone. Sound localization determines ability to detect the origin of sound in direction and distance. Studies shows that sound localization mechanisms in mammalian auditory system uses several cues for sound source localization, including time- and level-differences between both ears, timing analysis, spectral information, correlation analysis and pattern matching. These have potential application into MEMS microphone to enhance the localization capability. In the development of bio-inspired MEMS microphone, a pair of circular membranes coupled together with a beam has been incorporated in the design. The coupling works as amplifier for magnitude difference and phase between responses of two membranes when incident angle of the sound differs. This provides directional information to be interpreted from the coupled device response.

Exploration of fly-inspired MEMS microphone which has capability of sound localization, show future potential in realization of advanced MEMS microphone utilizing special capability of living organism auditory system, such as high frequency band auditory, including ultra-sonic MEMS microphone inspired by bat, dog and dolphin [13].

### 5.2. Focus improvement on graphene membrane

Recent studies show that graphene based materials has promising potential in application into capacitive-based MEMS microphone. In fact, graphene has also been applied in studies of ribbon microphone [14]. As membrane is the key fundamental part in capacitive-based MEMS microphone, where the deflection of the diaphragm particularly influences the sensitivity of the device, further studies particularly in the graphene-based membrane is required. Besides MEMS microphone, graphene-based membrane has also been extensively studied in fabrication of Fabry-Perot interferometric sensor with multi-layers graphene membranes [15,16]. These studies indicate that graphene-based membrane has great potential in enhancing MEMS microphone performance. Future studies should give focus on the improvement of the graphene membrane itself including design optimization, membrane design, topology, and fabrication method.

## 6. Conclusion

Development of capacitive-based MEMS microphone technology has been extensively reviewed in this article. In this article we described capacitive type MEMS microphone as well as its working principles and performance parameters. Capacitive type MEMS microphone is widely studied due to its compatibility with MEMS fabrication technology. Recent innovation reveal that graphene is an excellent material as membrane for MEMS microphone shown by frequency response result from previous research. Graphene potential must be extend for future research.

## References

- [1] Microphone, in Van Nostrand's Scientific Encyclopedia, John Wiley & Sons, Inc., 2005.
- [2] G. Rasmussen, P. Rasmussen, Acoustical Transducer Principles and Types of Microphones, in Handbook of Noise and Vibration Control, John Wiley & Sons, Inc., 2007, p. 435–443.
- [3] N. Hall, Electrostatic MEMS Microphones, in Encyclopedia of Nanotechnology SE - 317, B. Bhushan, Ed. Springer Netherlands, 2012, p. 775–783.
- [4] Y. Jung, Y.H. Lee, J. Kwak, S. Hur, Development of Capacitive Type Mems Microphone With Simullation and Electro-Mechanical Characterization, in XX IMEKO World Congress Metrology for Green Growth, 2012.
- [5] C.T. Yang, J. Mar. Sci. Technol., 18 (2010) 6.
- [6] A.S. Sezen, J. Biomech. Eng., 127 (2005) 6.
- [7] M.J. Crocker, General Introduction to Noise and Vibration Transducers, Measuring Equipment, Measurements, Signal Acquisition, and Processing, Handb. Noise Vib. Control, 2007. p. 415–434,
- [8] D. Todorovi, A. Matkovi, M. Mili, 2D Mater., 2 (2015) 4.
- [9] Q. Zhou, J. Zheng, S. Onishi, M. F. Crommie, A.K. Zettl, Graphene electrostatic microphone and ultrasonic radio, Proc. Natl. Acad. Sci., 112 (2015) 29.
- [10] D. Gee, H. Liu, L. Currano, Y. Miao, Enhanced directional sensitivity of a biomimetic MEMS acoustic localization sensor, in Proceedings of SPIE - The International Society for Optical Engineering, 2010, vol. 7682.
- [11] L. J. Currano, H. Liu, D. Gee, B. Yang, M. Yu, Microscale implementation of a bio-inspired acoustic localization device, in Proceedings of SPIE - The International Society for Optical Engineering, 2009, vol. 7321, p. 73210B–73210B–8.
- [12] A. Reid, J.F.C. Windmill, D. Uttamchandani, Procedia Eng., 120 (2015).
- [13] H. Tian, C. Li, M.A. Mohammad, Y.L. Cui, W.T. Mi, Y. Yang, D. Xie, T.L. Ren, ACS Nano, 8 (2014) 6.
- [14] P. Gaskell, R.E. Gaskell, J.W. (Jonathan) Hong, T. Szkopek, Graphene Oxide Based Materials as Acoustic Transducers: A Ribbon Microphone Application Case Study, in Audio Engineering Society Convention 137, 2014.
- [15] C. Li, J. Xiao, T. Guo, S. Fan, W. Jin, Mater. Res. Innov., 19 (2015) S5.
- [16] C. Li, Q. Liu, X. Peng, S. Fan, Opt. Express, 23 (2015) 21.