

Low Power Wide Area as a technology for Internet of Things

T. Januš

FEEC, Department of microelectronic
Brno University of Technology
Brno, Czech Republic
xjanus05@vutbr.cz

Anotace:

Internet of Things (IoT) se již postupně stává součástí každodenního života. Avšak vývoj takových aplikací je složitý z několika důvodů, např. použitelnost v těžce dostupných místech a s tím související napájení daného zařízení, odolnost zařízení a mnoho dalších. Hlavním důvodem je však existence různých protokolů IoT, z čehož plynou problémy se standardizací IoT jako celku. Z pohledu systému lze IoT řešení rozdělit do tří kategorií: sběrač dat, služba cloudové platformy a způsob komunikace. Sběračem dat je rozuměno zařízení, které pomocí senzorů získává data. Cloudové platformy nám tato všechna data uloží na bezpečné místo. Propojení mezi zařízením a cloudem nám zprostředkovává komunikační protokol. Jednotlivé komunikační protokoly se liší šířkou pásma, dosahem a množstvím připojitelných zařízení.

Annotation:

Internet of Things (IoT) is gradually becoming a part of everyday life. However, the development of such applications is complicated for several reasons, such as usability in hard-to-reach locations and associated power to the equipment, equipment durability, and many others. The main reason, however, is the existence of various IoT protocols, resulting in problems with the standardization of IoT as a whole. From a system perspective, the IoT solution can be divided into three categories: data collector, cloud platform service, and communication method. Data collector is a device that acquires data using sensors. Cloud platforms store all this data in a safe place. The communication between the device and the cloud provides us with a communication protocol. Individual communication protocols differ in bandwidth, range and number of connectable devices.

INTRODUCTION

Studies show that several billion devices will be connected to IoT by 2020. This is due, among other things, to the increasing demand for applications that do not require human intervention. The reason may be the inaccessibility of the device for reading the measured data (e.g. elevated places or water meter readings). Such places carry another problem, namely impaired signal reception. Other requirements for IoT devices include high reliability, enough transmit power with associated area coverage, battery life over the years, and low production costs. Access technologies for such IoT applications are referred to as LPWA (Low Power Wide Area) [1].

To build a successful IoT system, choosing the right technology or mix of technologies is needed. Depending on the IoT application, end users may decide to consider the importance of six key decision criteria differently: coverage, data throughput, mobility, latency, battery life and cost.

LICENSED VS. UNLICENSED SPECTRUM LPWA

There are two primary categories of LPWAN technologies: licensed and unlicensed.

Licensed LPWA uses existing transmitters from wireless cellular network operators. Mobile network operators have long-term licenses to operate within the dedicated spectrum. This provides highly reliable and secure environments. These include NB-IoT, LTE, LTE-M. These are supported on the licensed spectrum with carrier-level security.

Unlicensed LPWA technology can be used in specified frequency bands without permission. Wi-Fi routers, cordless phones, remote controls, and other communication devices also have access to unlicensed spectrum, which can cause interference - and thus reduce performance. Unlicensed spectrums usually offer limited coverage, lack of security and do not always support bidirectional communication. This is because most unlicensed LPWA technologies do not support software and firmware updates. The license-free frequency spectrum varies by region. The region of Europe can be used ISM bands 169 MHz, 433 MHz and 868 MHz and 2.4 GHz. Frequency bands below 1 GHz have the advantage of better environmental penetration and, in combination with narrow band transmission, coverage can also be achieved in locations such as the cellars of buildings.

Nowadays Sigfox and LoRa (Long Range) are important representatives for LPWA license-free technologies. Both technologies use the frequency

band below 1 GHz and aim for wireless M2M / IoT communication [1].

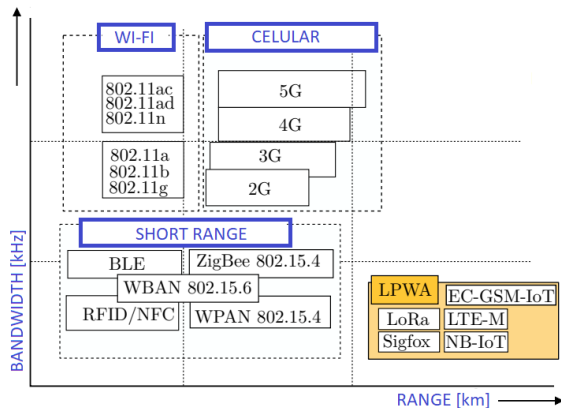

Fig. 1: Deployment with LPWA technology depending on range and width band

LORA

LoRa is a cell-free modulation technology for LoRaWAN. These two terms - LoRa and LoRaWAN - are not interchangeable: LoRaWAN is a standard WAN communication protocol, and LoRa is used as a broadband network technology.

Like Sigfox, LoRa uses unlicensed ISM bands, i.e., 433 MHz in Asia, 868 MHz in Europe and 915 MHz in North America. The bidirectional communication is provided by the chirp spread spectrum (CSS) modulation that spreads a narrow-band signal over a wider channel bandwidth. The resulting signal has low noise levels, enabling high interference resilience, and is difficult to detect or jam. In 2015 the company was standardized by Lora Lora-Alliance, and is deployed in 43 countries and in other countries is still fed by investing various mobile operators (e.g., KPN in the Netherlands and the Fastnet in South Africa). [1]

The technology is managed by the Lora Alliance, an industry association. The Alliance claims that Lora is capable of 155 dB MLC. It provides bidirectional and secure communication in the ISM band 867 - 869 MHz. 128 AES encryption is used. The use of the LoRa channel is limited by the usable channel alternation 1% (consumer channel time). Communication between terminal devices and gateways is done using a specific LoRa protocol without IP. [1]

Security is a primary concern for any mass IoT deployment and the LoRaWAN specification defines two layers of cryptography:

- A unique 128-bit Network Session Key shared between the end-device and network server
- A unique 128-bit Application Session Key (AppSKKey) shared end-to-end at the application level

SIGFOX

No LPWAN article would be complete without mentioning Sigfox. Sigfox was developed in 2010 as a start-up with the same name Sigfox. Sigfox company operates and markets its own solution to the IoT in 31 countries and through partnerships with various network operators are increasingly implemented worldwide. [1]

Sigfox technology works in 868 MHz license-free ISM band (906MHz in USA, 868 MHz Europe). Sigfox deploys its proprietary base stations equipped with cognitive software-defined radios and connect them to the back end servers using an IP-based network. The end devices connected to these base stations using binary phase-shift keying (BPSK) modulation in an ultra-narrow band (100 Hz) sub-GHZ ISM band carrier. [1]

Characteristics of the Sigfox network:

- Sigfox has the lowest cost of radio modules (<\$ 5, compared to ~ \$ 10 for LoRa and \$ 12 for NB-IOT).
- Sigfox is only uplink. Although a limited downlink is possible, it has a different link budget and is very limited.
- Sigfox is a comprehensive network and technology player.
- Each packet sent can have anywhere between 0-12 bytes of payload data
- Each packet transmits in about 2 seconds

The transmission of SigFox communication uses the so-called UNB (Ultra Narrow Band) band for transmitting only a short pulse of data with transmission power limited to 100 mW and modulation operating in the 200kHz public band. Each transmitted message occupies a bandwidth of 100 Hz at the time of transmission and is transmitted at 100 or 600 bps (depending on the region). This solution ensures long range and high immunity to interference. The transfer rate is 100 bps maximum size of transmitted UL message 12 B and DL message 8 B Channel Usage is limited by alternation (1%), thus limited channel usage time to 36 seconds per hour. Other limitations are also the maximum number of messages transmitted per day (140 messages UL and 4 DL messages) and maximum transmit power (14 dBm UL and 27 dBm DL) [1].

NB-IoT

NB-IoT is a narrow band mobile technology described in Third-Generation Partnership Project (3GPP) edition 13 it's for IoT communication (2016). It uses many LTE principles and building blocks of a large layer. The goal technology can be connected to a large number of devices with available throughput, available delay sensitivity, affordable energy consumption and

low power consumption communication modules. NB-IoT technology has been designed to provide greater coverage of territory other than GSM networks, coverage up to 164 dB MCL (20 dB more than GPRS). On should be secured even in unavailable targets, which are cellars building, which is possible thanks to the single-tone UL broadcast. New sensor layers and devices such as synchronization and physical random-access channel are solved for extended coverage and reduced equipment complexity. Higher protocols such as a The processing layers are simplified to reduce the efficiency of complexity and from that resulting in reduced energy consumption of the equipment [1].

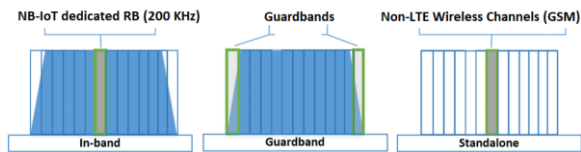

Fig. 2: NB-IoT operation mode

The NB-IoT supports 3 modes of operation as shown in Fig. 1:

1. In-band operation: It exists within the LTE carrier, which one resource block in the LTE network is reserved for NB-IoT.
2. Guard band operation: It operates in the guard band immediately adjacent to the LTE carrier, without affecting the capacity of the LTE carrier. With this variety of choices, the operator can choose the most suitable operation mode to satisfy its network performance requirement while offering the services to IoT applications [9].
3. Stand-alone operation: It uses re-farmed GSM low band already existing in many countries (700 MHz, 800 MHz and 900 MHz)

NB-IoT devices boast battery life of over 10 years, of course, depending on the application. Such possibilities Peak to Average Power Ratio (PAPR) and payment modes PSM and eDRX consumption [6]. NB-IoT enables FDD HD, accepts either PRB or 180 kHz bandwidth. For DL a multiple OFMDA approach with QPSK subcarrier modulation is used. For UL 2 models available with SC-FDMA and subcarrier modulations $\pi / 4$ -QPSK and $\pi / 2$ -QPSK for single broadcast and QPSK for multitone. For single broadcast broadcasting available 15 kHz remote subcarriers (12 subcarriers in PRB) or 3.75 kHz open subcarriers (48 subcarriers in PRB). For multitone available 15 kHz direct subcarriers. [1]

The transfer rates are up to 200 kbps for DL and up to 20 kbps UL. Latency is harmful NB-IoT offers three levels of coverage: Normal (CE level 0, MCL 144 dB), Robust (CE Level 1, MCL 154 dB) an Extreme (CE Level 2, MCL 164 dB). [1]

Tab. 1: Overview of properties of the above mentioned LPWA technologies

Network	SigFox	LoRa	NB-IoT
Spectrum	ISM 868 MHz	ISM 868 MHz	LTE a GSM
Transmitting power	14 dBm	14 dBm	20, 23 dBm
Multiple access	RFTDMA	TDMA	SC-DMA U L OFDMA DL
Modulation	DBPSK UL GFSK DL	CSS (SF7 – SF12)	BPSK QPSK
Bandwidth	100 Hz	125 kHz	180 kHz
MLC	159 dB	155 dB	164 dB
Duplex	HD	HD	HD FDD
Max messages per day	140 (UL) 4 (DL)	No limit	No limit
Baud rate	100 b/s	300 b/s to 50 kb/s	27 kb/s DL 32 kb/s UL
Max message length	12 B (UL) 8 B (DL)	51 až 243 B	1280 B
Encryption	AES 128 b	AES 128 b	LTE Encryption
Localization	RSSI	TDOA	E-CID, OTDO A
Standardization	company Sigfox	alliance LoRa	3GPP

3GPP RELEASE 14 NB-IoT

NB-IoT, the cellular Narrowband IoT protocol was standardized for the first time in the 3GPP Release 13 and enhanced in the 3GPP Release 14. The 3GPP Release 13 specification standardized the NB-IoT protocol for providing narrowband wide-area connectivity for massive machine-type communications for IoT. The first NB-IoT specification provided the underlying air interface standard for an ultra-low complexity NB1 device class with a long battery life. [1]

Overview of the 3gpp release 14 enhanced NB-IoT:

- Allocates new NB-IoT frequency bands
- Enhances device mobility
- Increases peak data rates
- Introduces NB-IoT Multicast
- Increases NB-IoT positioning accuracy
- Adds a lower device power class
- Introduces NB-IoT Multi-carrier operation

NB-IoT quickly gained the reputation of the de-facto cellular protocol of LPWA IoT. With the advent of the NB-IoT 3GPP Release 14 specification, the LTE Cat NB2 protocol becomes a faster, more robust, and more energy-efficient wireless protocol. Device manufacturers or developers can customize their NB-IoT applications to smaller devices, enabling efficient firmware and software updates that require synchronous group communication and accurate location. [1]

CONCLUSION

Increasing requirements for applications requiring periodic data sending without necessity. The human factor results in a massive increase in M2M (Machine-to-Machine) communication equipment for the Internet of Things. Requirements for such applications are, for example, provided enough coverage even in inaccessible places (mountain areas, underground areas), Acceleration of measured data collection and ability to function in years. Access technologies for such IoT applications are referred to as LPWA.

In this paper it is shown that LoRa, Sigfox and NB-IoT have their advantages and disadvantages according to their different technological principles. In general, there is no unique LPWA technology, but the most appropriate technology for a specific application. Each application has its own specific requirements that lead to the selection of a technology. LoRa and Sigfox focuses on cheap applications. Meanwhile, NB-IoT is focused on applications that require high QoS and low latency.

Vodafone now operates the NB-IoT network in the Czech Republic. Indicates that coverage is more than 99%. Veolia Energie ČR used this fact to continuously check the reliability and security of heat supplies to customers. The developer has released a package containing 20 sim cards (either plastic or integrated into the chip) for a testing period of 6 months. The monthly maximum data consumption per sim card is 50 MB. The price of such a package is around 100 €.

REFERENCES

- [1] Ali A., Hamouda W. On the Cell Search and Initial Synchronization for NB-IoT LTE Systems. *IEEE Commun. Lett.* 2017;21:1843–1846. doi: 10.1109/LCOMM.2017.2700864.
- [2] Sigfox - The Global Communications Service Provider for the Internet of Things (IoT), [online] Available: <https://www.sigfox.com/en>.
- [3] Bardyn J., Melly T., Seller O., Sornin N. IoT: The era of LPWAN is starting now; Proceedings of the ESSCIRC Conference 2016: 42nd European Solid-State Circuits Conference; Lausanne, Switzerland. 12–15 September 2016; pp. 25–30.
- [4] WU, Jian Hua. CAT-M & NB-IoT Design and Conformance Test [online]. In: . Keysight Technologies, 2017, 14.6.2017, 1 – 53 [cit. 2019-09-17]. Available: https://www.keysight.com/upload/cmc_upload/All/20170612-A4-JianHuaWu-updated.pdf.
- [5] LoRa Alliance 2017 End of Year Report, Sep. 2019, [online] Available: <https://lora-alliance.org/sites/default/files/2018-04/LoRa-Alliance-Annual-Report.pdf>.
- [6] Amy Nordrum, "Popular internet of things forecast of 50 billion devices by 2020 is outdated", *IEEE SPECTRUM*, August 2016, [online] Available: <https://spectrum.ieee.org/tech-talk/telecom/internet/popularinternet-of-things-forecast-of-50-billion-devices-by-2020-isoutdated>.
- [7] LoRa world coverage available in: www.lora-alliance.org/. Google Scholar
- [8] Wang Y.E., Lin X., Grovlen A., Sui Y., Bergman J.A primer on 3GPP narrowband internet of things. *IEEE Commun. Mag.*, 55 (3) (2016), pp. 117-123
- [9] Boisguene, Rubbens & Tseng, Sheng-Chia & Huang, Chih-Wei & Lin, Phone. (2017). A survey on NB-IoT downlink scheduling: Issues and potential solutions. 547-551. 10.1109/IWCMC.2017.7986344.
- [10] Vodafone, <https://www.vodafone.cz/internet-veci/>.

ACKNOWLEDGMENT

The article was supported by project no. FEKT-S-17-3934, Utilization of novel findings in micro and nanotechnologies for complex electronic circuits and sensor applications.