

Formula Expression of Airgap Leakage flux Coefficient of Axial-Flux Permanent Magnet Motor

Xiao Gong¹, Yanliang Xu¹, Feng Xin²

¹School of Electrical Engineering, Shandong University, Jinan, China

² Shandong Supervision and Inspection Institute for Product Quality, Jinan, China

e-mail: xuyanliang@sdu.edu.cn

Abstrak

Koefisien flux bocor celah udara merupakan salah satu parameter utama yang harus ditentukan terlebih dahulu pada desain awal atau untuk memperoleh perbaikan kinerja yang dihasilkan dari analisis rangkaian magnetik untuk suatu jenis mesin listrik. Metode Finite Element tiga dimensi adalah metode yang paling handal untuk memperoleh koefisien flux bocor yang akurat untuk motor axial-flux permanent magnet (AFPM) sekalipun membutuhkan waktu yang lama dan tidak menguntungkan terhadap perancangan awal maupun perancangan optimalisasi motor tersebut. Dengan mengganti model accurate lumped-parameter magnetic circuit (LPMC) dan menghitung reluctance magnetik resultannya, persamaan analitik untuk koefisien flux bocor dari suatu AFPM dapat diperoleh dan diverifikasi menggunakan metode Finite-element 3D serta percobaan terhadap AFPM yang dipurwarupakan.

Kata kunci: Axial-flux permanent magnet motor (AFPM), leakage flux coefficient, lumped-parameter magnetic circuit (LPMC), 3D-FEM

Abstract

Airgap leakage flux coefficient is one of the main parameters which must be given ahead of time when performing initial designs or getting performance results by magnetic circuit analysis for any kinds of electrical machines. Three-dimensional finite element method (3D-FEM) is the most reliable one to obtain the accurate leakage flux coefficient for axial-flux permanent magnet (AFPM) motor which definitely takes a much long time and is not advantageous to the motor's initial and optimal design. By constituting the accurate lumped-parameter magnetic circuit (LPMC) model and computing the resultant magnetic reluctances, the analytical formula of the leakage flux coefficient of AFPM is given which is verified by 3D-FEM and the prototyped AFPM experiment.

Key Words: Axial-flux permanent magnet motor (AFPM), leakage flux coefficient, lumped-parameter magnetic circuit (LPMC), 3D-FEM.

1. Introduction

Axial-flux permanent magnet motor (AFPM) combines the advantages of disk motor and permanent magnet motor which has high efficiency, high power density, high ratio of torque vs. moment of inertia, Therefore it can be used in direct-drive, low speed and high torque field such as landsport application, aeronautical field or wind power generation system.

Three-dimensional finite element method (3D-FEM) is the most reliable one used to design and analyze the AFPM, which definitely results in a time-consuming process and is obviously unsuitable for its initial and optimal design. Therefore, magnetic circuit method should be usually used at first for the AFPM as does for the normal radial-flux electric motor, and then 3D-FEM is employed to verify the analysis and design. Airgap leakage flux coefficient is one of the main parameters which must be given primarily in magnetic circuit analysis for any kinds of electric machines including the AFPM. The airgap leakage flux coefficient of several kinds of motors are calculated in [1, 2] with the help of FEM, and the figures which describe relationship between the coefficient and the motor's geometrical dimensions are depicted. Especially in Reference[1], one 3D-FEM analysis for AFPM is transmitted equivalently to two two-dimensional(2D) FEM ones named as radial-orientation one and axial-orientation one respectively to get their respective leakage flux coefficients, then the whole airgap leakage flux coefficient of AFPM is achieved by the two ones with the help of an empirical coefficient.

Lumped-parameter magnetic circuit (LPMC) is very efficient in the analysis and design of electric machine, by which analytical expressions for the motor's parameters such as airgap leakage flux coefficient can be given. In paper [3], the lumped parameter magnetic circuit of a radial flux motor was constituted to analyze the flux density and leakage flux. Paper [4, 5] adopted the same method to analyze flux switch motors and obtained a satisfactory result. However flux field in AFPM is three dimensional, the leakage flux is very different from that in radial flux motors. Therefore in order to obtain an accurate airgap leakage flux coefficient in AFPM conveniently, a more complex and accurate 3D lumped-parameter magnetic circuit model is constituted firstly in this paper, and then an analytical expression of the leakage flux coefficient is obtained which was verified by 3D-FEM and the prototype experiment.

2. Lumped Parameter Magnetic Circuit Model of AFPM

The AFPM with fan-shaped magnet pole is given in Figure 1, and its simple linear translational motor topology which consists of circumferential one and radial one are shown in Figure 2 (a) and (b) respectively. To simplify the problem, it is assumed that there is no saturation occurring in the steel region and the flux density produced by the armature current in the stator windings is negligible. In Figure 2, the path 1 represents that of main air-gap flux generated from region 1 as shown in Figure 3, path 2 represents that of magnet-to-magnet leakage flux generated from region 2 as shown in Figure 3 and paths 3-5 refer to that of magnet-to-rotor leakage fluxes respectively from regions 3,4 and 5 as shown in Figure 3. It is obvious that every region area in Figure 3 relies on the motor structure variables which will be determined in the following sections. According to Figure 2 and 3, the equivalent lumped-parameter magnetic circuit model of AFPM can be constituted as shown in Figure 4, where the variables are defined as follows.

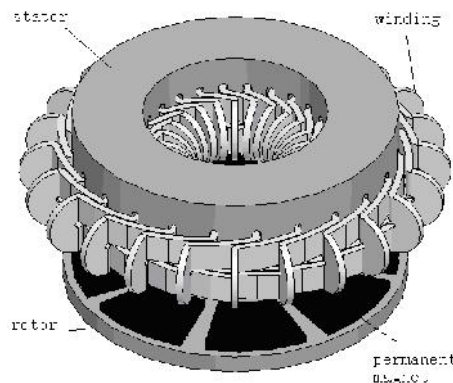

Figure1. Construction of AFPM

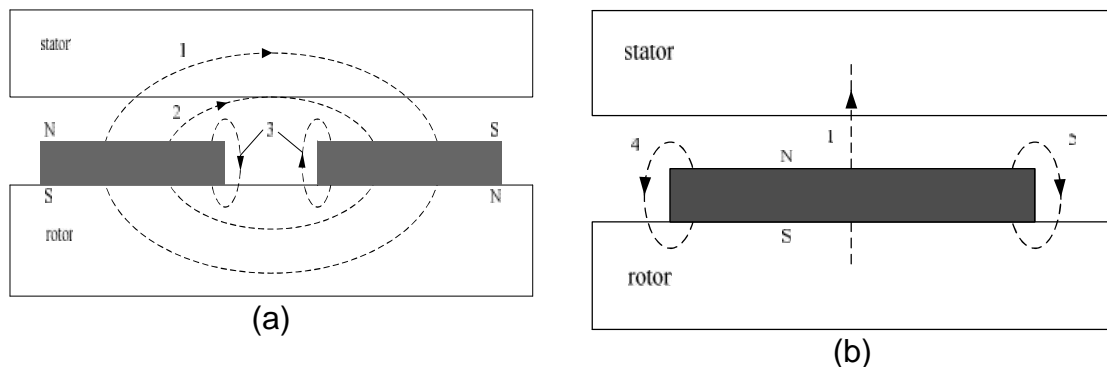

Figure 2. Simple linear translational AFPM topology

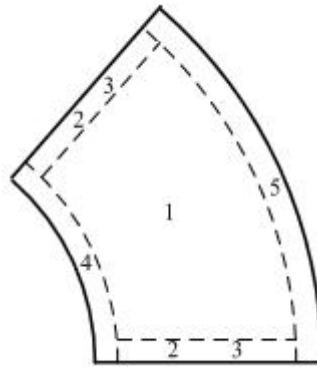

Figure 3. Subregions of flux-passing area of magnet

Where:

W air-gap flux for one magnet pole;

W_r flux source of one magnet pole;

R reluctance corresponding to W ;

R_m reluctance of a magnet, corresponding to W_r ;

R_{mm} reluctance corresponding to magnet-to-magnet leakage flux from region 2 in Figure 3;

R_{mr} reluctance corresponding to magnet-to-rotor leakage flux from region 3 in Figure 3;

R_{mi} reluctance corresponding to magnet-to-rotor leakage flux from region 4 in Figure 3;

R_{mo} reluctance corresponding to magnet-to-rotor leakage flux from region 5 in Figure 3.

Figure 4 can be reduced to Figure 5 easily, and air-gap flux and the flux leaving from the magnet can be obtained as [3].

$$\Phi_u = \frac{\Phi_r}{1 + \frac{R_u}{R_m}(1 + r + s + 2y + 4)} \quad (1)$$

$$\Phi_m = \frac{1 + \frac{R_u}{R_m}(r + s + 2y + 4)}{1 + \frac{R_u}{R_m}(1 + r + s + 2y + 4)} \Phi_r \quad (2)$$

$$\text{Where, } r = \frac{R_m}{R_{mo}}, s = \frac{R_m}{R_{mi}}, y = \frac{R_m}{R_{mr}}, \} = \frac{R_m}{R_{mm}}.$$

From (1), (2) the air gap leakage flux coefficient can be expressed as

$$\dagger = \frac{\Phi_m}{\Phi_g} = 1 + \frac{R_u}{R_m}(r + s + 2y + 4) \quad (3)$$

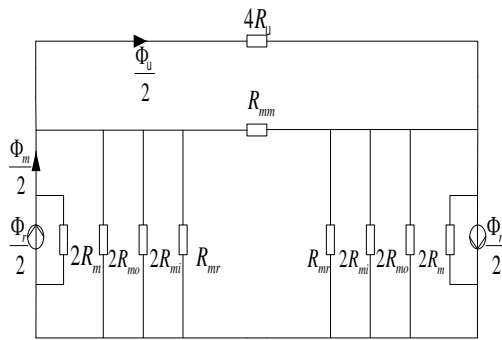

Figure 4. Equivalent LPMC of AFPM

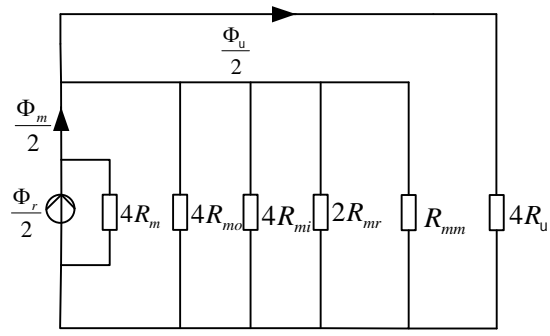

Figure 5. A reduced form of Figure 4

3. Calculation of Mensioned the Reluctances

3.1 Reluctances corresponding to air-gap and magnet

The reluctances corresponding to air-gap and magnet can be expressed as

$$R_u = \frac{u_e}{\mu_0 A_{eff}} \tag{4}$$

$$R_m = \frac{h_m}{\mu_r A_m} \tag{5}$$

where, h_m is the magnetizing height of magnet, μ_0 and μ_r are permeability of air and relative permeability of magnet respectively, u_e is effective length of the air gap taking into account the stator slotting, and A_m , A_{eff} are the flux passing area of magnet and that of the air-gap respectively and can be expressed as

$$A_m = \frac{f r_p (D_{mo}^2 - D_{mi}^2)}{8p} \tag{6}$$

$$A_{eff} = \frac{f r_p [(D_{mo} + u)^2 - (D_{mi} - u_e)^2]}{8p} \tag{7}$$

Where r_p is pole embrace coefficient, p is pole-pair number and D_{mo} , D_{mi} are the outer and inner diameter of magnet respectively.

3.2 Reluctances corresponding to magnet-to-rotor leakage flux from region 4 and 5

The expressions of the two reluctances can be obtained by calculating their permeances. The circular-arc straight-line permeance model [6] is one of the most satisfactory techniques for modeling flux flowing in the air gap, and that to model magnet-to-pole leakage flux from region 4 as depicted in Figure 6, so the resultant permeance P_{mi} is an infinite sum of differential permeances and can be obtained by the integral as:

$$P_{mi} = \int_{\frac{1}{2}D_{mi}}^{\frac{1}{2}D_{mi}+u} \int_0^{\frac{f}{2}r_p} \frac{\mu_0 r dr d_r}{f(r - \frac{1}{2}D_{mi}) + h_m} = \frac{\mu_0 r_p u}{p} + \frac{\mu_0 r_p}{p} (\frac{1}{2}D_{mi} - \frac{h_m}{f}) \ln \frac{f u + h_m}{h_m} \tag{9}$$

In a same way the leakage flux permeance corresponding to magnet-to-magnet leakage flux from region 5 can be obtained as

$$P_{mo} = \int_{\frac{1}{2}D_{mo}-u}^{\frac{1}{2}D_{mo}} \int_0^{f-r_p} \frac{\sim_0 r dr d_n}{f(\frac{1}{2}D_{mo}-r)+h_m} = -\frac{\sim_0 r_p u}{p} - \frac{\sim_0 r_p}{p} (\frac{1}{2}D_{mo} + \frac{h_m}{f}) \ln \frac{h_m}{fu+h_m} \quad (10)$$

Equation (10) is solved under the condition that the difference between the outer radius of magnet and that of rotor is more than or equal to δ_e , if this difference is less than δ_e , replace δ_e in equation (10) with this difference. Equation (9) is solved under the condition that the difference between the inner radius of magnet and that of rotor is far larger than δ_e .

Using the above equations, and noting that the reciprocal relationship between reluctance and permeances, the needed reluctances can be expressed as:

$$R_{mi} = \frac{1}{P_{mi}} \quad (11)$$

$$R_{mo} = \frac{1}{P_{mo}} \quad (12)$$

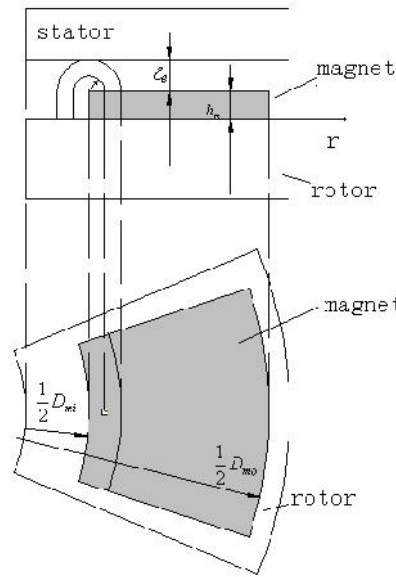

Figure 6. Permeance model of magnet-to-rotor leakage flux form region 4

3.3 Reluctances corresponding to magnet-to-rotor leakage flux from region 3 and magnet-to-magnet leakage flux

Based on Figure 3, the circular-arc straight-line permeance models describing the magnet-to-rotor leakage flux from region 3 and magnet-to-magnet one can be depicted as in Figure 7 and Figure 8 respectively, and the resultant permeances can be easily achieved as

$$P_{mr} = \int_{\frac{1}{2}D_{mi}+u}^{\frac{1}{2}D_{mo}-u} \int_0^u \frac{\sim_0 r dr d_n}{f r_n + h_m} = \frac{\sim_0}{f} (\frac{1}{2}D_{mo} - \frac{1}{2}D_{mi} - 2u) \ln \frac{fu+h_m}{h_m} \quad (13)$$

$$P_{mm} = \int_{\frac{1}{2}D_{mi}+u}^{\frac{1}{2}D_{mo}-u} \int_0^u \frac{\sim_0 r dr d_n}{f r_n + r \frac{f}{p} (1-r_p)} = \frac{\sim_0}{f(1-r_p)} [p u \ln \frac{p u + (\frac{1}{2}D_{mo}-u)(1-r_p)}{p u + (\frac{1}{2}D_{mi}+u)(1-r_p)} + \quad (14)$$

$$(\frac{1}{2}D_{mo}-u)(1-r) \ln \frac{p u + (\frac{1}{2}D_{mo}-u)(1-r_p)}{(\frac{1}{2}D_{mo}-u)(1-r_p)} + (\frac{1}{2}D_{mi}+u)(1-r_p) \ln \frac{(\frac{1}{2}D_{mi}+u)(1-r_p)}{p u + (\frac{1}{2}D_{mi}+u)(1-r_p)}]$$

If the distance between two adjacent magnet is less than $\frac{e}{2}$, replace e with $D_{mi}(1-p)/4p$ in Equation (13).

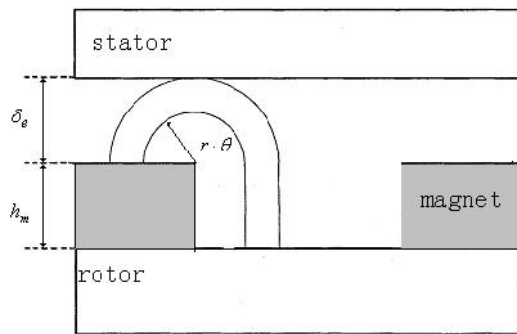

Figure 7. Permeance model of magnet-to-rotor leakage flux form region 3

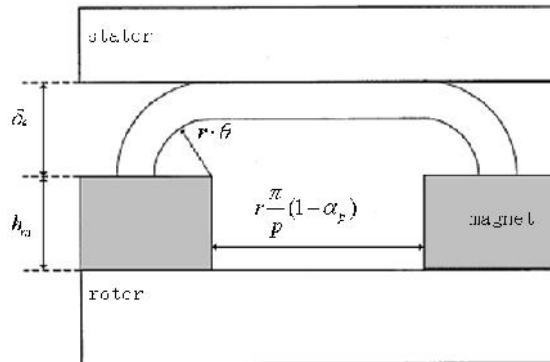

Figure 8. Permeance model of magnet-to-magnet leakage flux

3.4 The formula expression of airgap leakage flux coefficient

From the mentioned reluctances, we can obtain the parameters of Equation 3 as follows:

$$r = \left[-\frac{r_p u}{p} - \frac{r_p}{p} \left(\frac{1}{2} D_{mo} + \frac{h_m}{f} \right) \ln \frac{h_m}{f u + h_m} \right] \frac{h_m}{f A_m} \quad (15)$$

$$s = \left[\frac{r_p u}{p} + \frac{r_p}{p} \left(\frac{1}{2} D_{mi} - \frac{h_m}{f} \right) \ln \frac{f u + h_m}{h_m} \right] \frac{h_m}{f A_m} \quad (16)$$

$$y = \frac{h_m}{f A_m} \left(\frac{1}{2} D_{mo} - \frac{1}{2} D_{mi} - 2u \right) \ln \frac{f u + h_m}{h_m} \quad (17)$$

$$\begin{aligned} z = & \frac{h_m}{f(1-r_p) A_m} \left[\mu \ln \frac{\mu + \left(\frac{1}{2} D_{mo} - u \right) (1-r_p)}{\mu + \left(\frac{1}{2} D_{mi} + u \right) (1-r_p)} + \left(\frac{1}{2} D_{mo} - u \right) (1-r_p) \ln \frac{\mu + \left(\frac{1}{2} D_{mo} - u \right) (1-r_p)}{\left(\frac{1}{2} D_{mo} - u \right) (1-r_p)} \right. \\ & \left. + \left(\frac{1}{2} D_{mi} + u \right) (1-r_p) \ln \frac{\left(\frac{1}{2} D_{mi} + u \right) (1-r_p)}{\mu + \left(\frac{1}{2} D_{mi} + u \right) (1-r_p)} \right] \quad (18) \end{aligned}$$

And then the air gap leakage flux coefficient can be easily obtained from Equation (3).

4. 3-D FEM and Prototype Experiment Verification

The prototyped AFPM with nominal specifications of 48 V_{DC}, 4 kW and 3000 rpm is used to verify the above LPMC and then the leakage flux coefficient formula by its 3D-FEM result and no-load prototype experiment. Its dimension specifications are given in Table 1, and Figure 1, Figure 9 are its 3-D FEM structure and mesh grid diagram respectively. The air gap leakage flux coefficient of prototyped AFPM are calculated with methods of LPMC and 3D-FEM respectively when factitiously changing the air-gap length u_e and pole embrace coefficient r_p and the comparison results are shown in Table 2. From Table 2 it can be seen that air gap leakage flux coefficient of AFPM calculated with LPMC is very close to that with 3D-FEM. The prototyped AFPM is fabricated as shown in Figure 10, which employs a little different rotor

magnet structure compared with the mentioned AFPM model in the flank shape but with average pole embrace coefficient of 0.9. The maximum value of no-load permanent magnet induced voltage can be obtained as shown in Table 3 through the following three methods as (1) magnetic circuit based on the presented LPMC and the resultant leakage flux coefficient, (2) 3D-FEM and (3) prototype experiment. It should be mentioned that the 3D-FEM result is based on the same rotor magnet structure as the prototyped one but the magnetic circuit calculation is based on the ideal rotor magnet structure of the foregoing analysis. From Table 3 It can be seen that the magnetic circuit calculation is just a little difference from the 3D-FEM and prototype experiment mainly resulting from a little rotor magnet structure difference. From the mentioned comparisons of air gap leakage flux coefficient and no-load permanent magnet induced voltage from different method, the presented LPMC and leakage flux coefficient formula of AFPM has very high accuracy and is valid and suitable for the purpose of design and optimization.

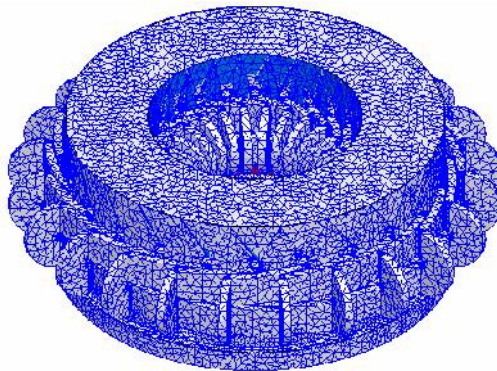

Figure 9. Mesh grid diagram of the prototyped AFPM



Figure 10. Stator and rotor of the prototyped AFPM

Table 1. Dimension specifications of prototype

| Specifications | Dimensions |
|------------------|------------|
| Pole-pair number | 4 |
| D_{mo} (mm) | 83 |
| D_{mi} (mm) | 147 |
| h_m (mm) | 4.3 |
| u_e (mm) | 3 |
| r_p | 0.9 |

Table 2. Leakage flux coefficient obtained from LPMC and 3D-FEM

| u_g/mm | r_p | LPMC result | 3D-FEM result | Error/ |
|-----------------|-------|-------------|---------------|--------|
| 3 | 0.9 | 1.1721 | 1.1357 | 3.1 |
| 3 | 0.8 | 1.1557 | 1.1015 | 4.7 |
| 3 | 0.7 | 1.1536 | 1.0968 | 4.9 |
| 2 | 0.9 | 1.0999 | 1.0773 | 2.0 |
| 2 | 0.8 | 1.0888 | 1.0509 | 3.5 |
| 2 | 0.7 | 1.0872 | 1.0499 | 3.4 |

Table 3. no-load Induced voltage of prototyped AFPM

| Prototyped AFPM | no-load Induced voltage (V) |
|-----------------|-----------------------------|
| LPMC method | 12.53 |
| 3D-FEM | 11.8 |
| Experiment | 11.52 |

5. Conclusion

An accurate lumped-parameter magnetic circuit of axial-flux permanent magnet motor is constituted in this paper, from which, analytical expression of air gap leakage flux coefficient is obtained. The resultant analysis and calculation is verified by 3-D FEM and experiment of a prototyped AFPM. As a result, the presented LPMC and air gap leakage flux coefficient formula of AFPM has very high accuracy and is valid and suitable for the purpose of design and optimization.

Acknowledgements

The authors would like to thank the National Natural Science Foundation of China (51277111/E070303) and Ji'nan City College Institute innovation Fund (201102038).

References

- [1] Tang Renyuan. Modern Permanent Magnet Machines-Theory and Design. Beijing: China Machine Press. 1997.
- [2] Wang Xiuhe. Permanent Magnet Motors [M]. Beijing: China Electric Power Press. 2007.
- [3] Qu Ronghai, Thomas A Lipo. Analysis and modeling of air-gap and zigzag leakage fluxes in a surface-mounted permanent magnet machine. *IEEE Transactions on Industry Applications*. 2004; 40(1): 121-127.
- [4] Yu Chen, Zhu Ziqiang. Three dimensional lumped parameter magnetic circuit analysis of single phase flux switching permanent magnet motor. *IEEE Transactions on Industry Applications*. 2008; 44(6): 1701-1710.
- [5] Zhu Ziqiang, et al. Analysis of electromagnetic performance of flux switching permanent magnet Machines by nonlinear adaptive lumped parameter magnetic circuit model. *IEEE Transactions on Magnetics*. 2005; 41(11): 4277-4287.
- [6] DC Hanselman. Brushless Permanent-magnet Motor Design. New York: McGraw-Hill.1994.
- [7] Lika, Reza, Gholamian S, Asghar. Optimum design of a five-phase PMSM underwater vehicles by use of PSO. *TELKOMNIKA*. 2012; 10(5): 925-932.
- [8] Yanliang Xu, Xiquan Liu. Development of tubular linear permanent magnet synchronous motor used in oil-well field. *TELKOMNIKA*. 2011; 9(3): 515-522.