

TELKOMNIKA, Vol.17, No.5, October 2019, pp.2497~2504

ISSN: 1693-6930, accredited First Grade by Kemenristekdikti, Decree No: 21/E/KPT/2018

DOI: 10.12928/TELKOMNIKA.v17i5.9926

■ 2497

Design and fabrication of cost-effective heart-rate pulse monitoring sensor system

Zulkhairi Mohd Yusof, Md Masum Billah*, Kushsairy Kadir, Nur Amanina,
Nur Hidayah, Haidawati Nasir

Universiti Kuala Lumpur (UniKL), Kuala Lumpur, Malaysia

*Corresponding author, e-mail: drmdmasum@unikl.edu.my

Abstract

A traditional approach of heart rate measurement has always meant that people must go to hospitals to examine the patient disease at Cardiologist and medical officer. Most people have difficult such as no transport and lazy to go to the hospital for the check-ups of their conditions heart rate. This is because, before have a treatment or medical check-up, they should do an appointment. Besides that, demands of works very high nowadays. People busy with their works until forget to do medical check-ups. Additionally, the available portable heart rate monitoring machine is costly to buy for all. In this research, we develop a system which can be accommodate for all while everyone can do their check up at home and do not waste their time by waiting for their turn in the hospital to do the medical check-ups. The prototype is built using low cost electronics components. The prototype can do a self-check-up before seeing a medical practitioner may reduce mortality rate due to the silent killer that is heart attacks.

Keywords: cost-effective, heart failure, LED, pulse

Copyright © 2019 Universitas Ahmad Dahlan. All rights reserved.

1. Introduction

Pulses can be defined as the number of heart beats that beats per minute (bpm). The heart rate normally depends on the relaxation and contraction of the ventricles in the heart which have two large chambers. The function of the ventricle is to expel and collect blood to peripheral beds from atrium within the lungs and body. If the person did not get enough rest, the person heart rate will be too slow (bradycardia) or the heart rate will be fast (tachycardia) than the normal heart rate. This tachycardia happen cause the person exercise, stress, trauma or illness disease. The causes of bradycardia are when the heart does not get enough oxygen rich blood for the body. Bradycardia and tachycardia can be considered as health problem.

First, place finger at the neck or wrist. Carotid pulse will be measure if the finger place at the neck but if the finger was place at the wrist, radial pulse will be measure. Normally, people use wrist to check the pulses. After placed the finger at the wrist or neck the person need to count over 10 seconds to estimate the beats per minutes and then multiply by 4. Repeat the same by count within 15 seconds and multiply by 4 and doubling the result. When use this method usually have an error of the pulses rate. This is because sometime, when we count, we can make mistakes. Figure 1 shows the manual checking of pulse rate.



Figure 1. Manual method [1]

Besides that, the monitor method also can be used in order to count the pulses. In this modern era technology, electrocardiogram (ECG) machines was usually use in the hospital. This is because electrocardiogram (ECG) is very expensive and only expert person can handle the machine cause it not easy to use. Nowadays with the modern technology, ECG also available applied in gadgets such watch and smartphone. Figure 2 shows the Holter monitor with ECG reading checking of pulse rate.

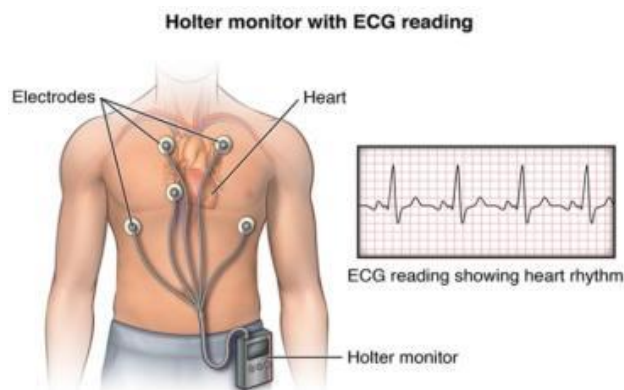

Figure 2. Monitor method [2]

Depolarization and re-polarization of myocardial cells is based on the electrical heart activity. To reach the atrioventricular node and to generate the contraction of atriums, the sinoatrial node (natural pacemaker) of electrical impulse will starts flowing through the atriums. Ventricular contractions will be generates by currents that flows, the current will flows through the Hiz Bundle and then reaches the ventricles. The heart tissue occur re-polarization and Punksinje fibers will be reaches by the currents. Figure 3 shows the behaviour Myocardium electrical activity.

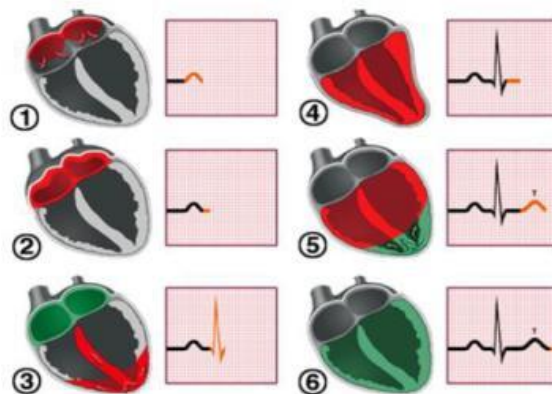

Figure 3. Myocardium electrical activity [3]

Figure 3 shows the heart behaviour with the QRS complex which means the part of the generated signal

1. Atrium begins to depolarize.
2. Atrium depolarizes.
3. Ventricles begin to depolarize at apex. Atrium repolarizes.
4. Ventricles depolarize.
5. Ventricles begin to repolarize at apex.
6. Ventricles repolarize

The word Greek electro have been derived, this is because it related to electrical activity. This word related to the meaning of heart, cardio and graph. Santorio Santorri was the first person that invented the pulsilogium which is a form of pendulum to measure accurately the pulse rate based on Galileo Galilei work. De Lacroix, physician after a century later used to test cardiac function by used pulsilogium [4].

In 1872 at St Bartholomew's hospital, the patient's heartbeat which has a fever was attached to the Alexander Munirhead [5]. This is because, he wants to obtain a record a patient's heart beat and he was studying his Doctor of Science. British physiologist, John Burdon Sanderson use Lippmann capillary electrometer to record the result [6]. Augustus Walker from St Mary's hospital in Paddigton, London was the first on that that approach electrical view of heart. He used Lippmann capillary electrometer electrocardiograph to fix the projector. His project allows heartbeat to be record in real time without any problem. His work project still be used in 1911 [7]. However, currently modern heart rate monitoring sensory systems are widely developed considering smart design and cloud-based system [8-13]. All these sensory systems are adequately connected with cloud server [14-20]. A realtime data transmission is also used to monitor the patient condition for online diagnosis purpose [21-25]. Therefore, these inspirations come to develop a realtime basis heart monitoring system.

2. Designs and Fabrication Process

Figure 4 shows the block of the whole concept and function for the pulses rate measurement in this work. This block diagram is made to understand the process implement in this project. The block diagram consist of four part which are the sensor (IR diode and Photodiode), the amplifier and filter, the microcontroller and the output (7 segment with LED). In this project, it have used the sensor which called infrared light-emitting-diode (IR diode) which is Transceiver and Photodiode (Receiver). IR diode will transmit the reading of the pulses and infrared light to the fingertip .The infrared light will reflected by the blood cells. Photodiode will receive the infrared light from IR diode and reflected it back to the fingertip. The little change in amplitude with the proper signal conditioning will reflected light and convert it into pulses.

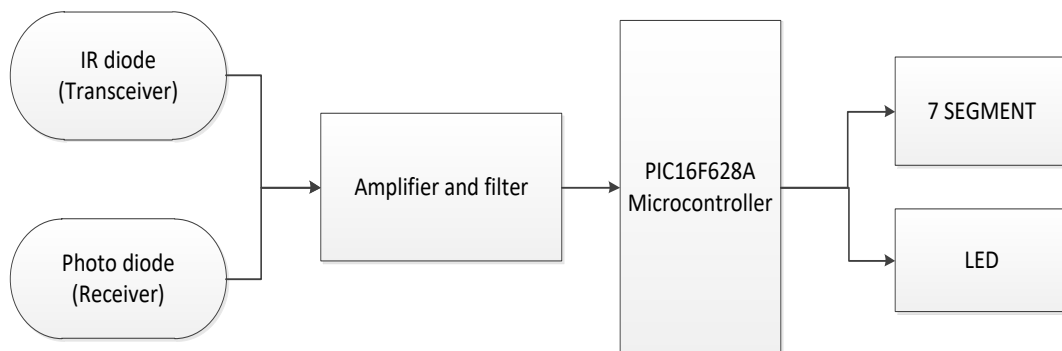

Figure 4. Block diagram of the pulses rate measurement

We design by used active low pass filter with two operational amplifier (Op-Amps) which are a two-stage and high gain which the function are to amplify and filter the appropriate voltage level from signal so that the pulses can be counted by using microcontroller. The active filter will amplify the signal and passing the certain selected frequencies. The AC voltage source will connected to the resistor R3 while the capacitor C1 will goes to the ground. Figure 5 shows the active low pass filter. With the used of microcontroller it will determine the pulses of heart beat. First, we want to make the project by using the results of the pulses will be display on 3 digit 7 segment with the shift of the LED.

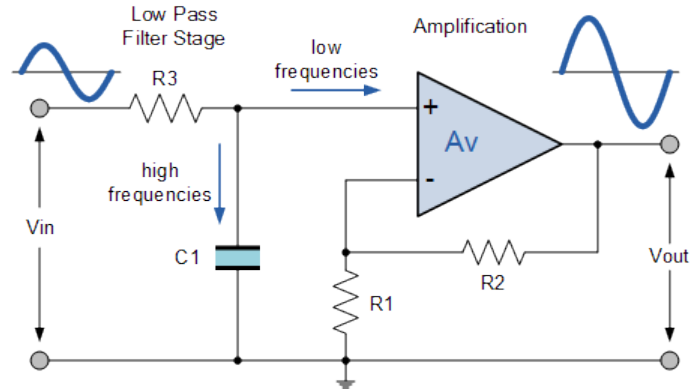

Figure 5. Active low pass filter [8]

2.1. Schematic Diagram

When the start button was pressed up, the pulses of clock start to operate as the input. The clock was placed over the IR diode (Transmitter/Tx) and Photodiode (Receiver/Rx). The sensor will configure the clock pulse by using IR diode and Photodiode. When the sensor detect the pulse of the clock, it will read the signal clock pulses rate, the signal from the sensor will be transferred and transmit to the PIC microcontroller. It read the clock pulse through the PIC16F628A. The pulse will be counted from the clock and send it to the PIC microcontroller. If the pulses is failed to detect by the sensor and the pulses do not display and show an error, the frequency of the clock pulse must be changed. When the clock pulse process by the PIC microcontroller, the results of the pulses will display on the 7 segment and the LED will shift. Figure 6 shows the schematic diagram that we designed in Proteus. Before we start construct the prototype, we designed the circuit in to check whether the connection is correct or not as shown in Figure 7. Then we change the design in Proteus to ARES to print the layout.

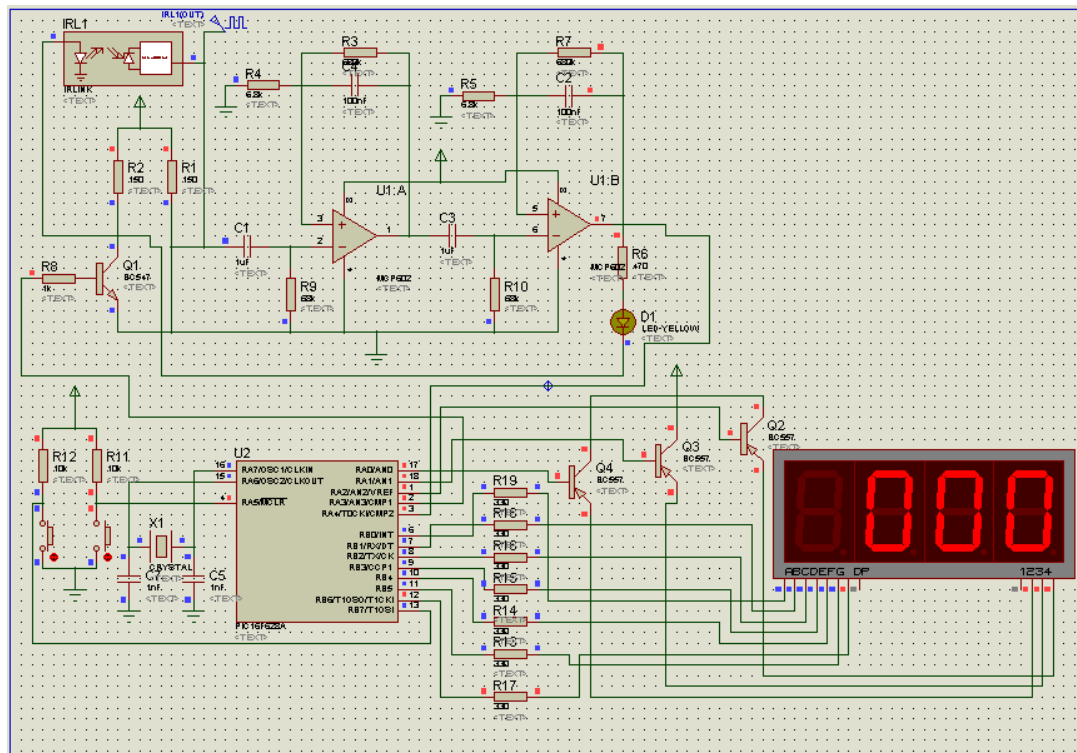

Figure 6. Schematic diagram in proteus

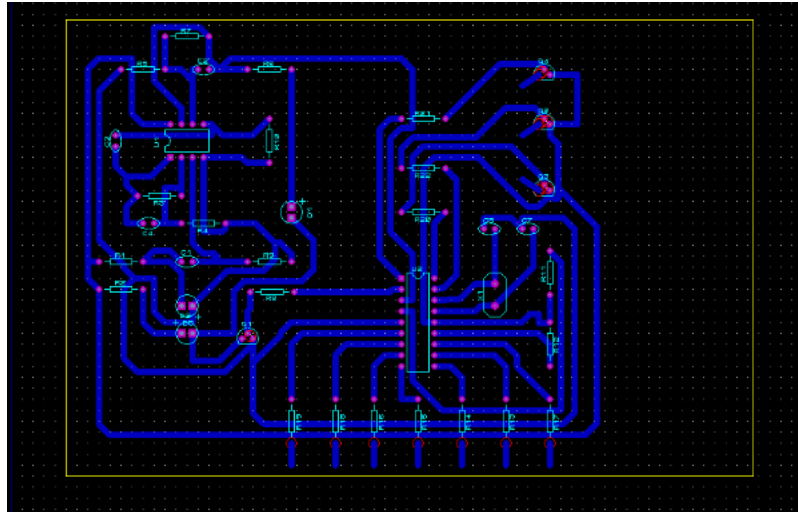

Figure 7. Design schematic in Proteus

2.2. PCB in the Making

Firstly, print laser ink the PCB layout on glossy paper that had been design on the ARES software. The PCB layout must be in laser ink so it easy the layout sticks when iron on the PCB Board. Then, place neatly the printed PCB layout on the PCB board. After that, iron the PCB layout on the PCB board based as shown in Figure 8.

After iron the layout on the PCB board, we soaked the PCB board in the acid powder and add up some warm water. This Figure 9 shows etching process. The function of this etching process is to remove the copper layer on the board and the layout stick on the PCB Board. Be careful handling the acid. After the copper remove, wash it with water and brush the PCB layout. Lastly, we can see the copper shaped layout in Figure 9.

After finished drill the PCB board, place and construct the correct component on the PCB board. Construct the component based on the simulation to avoid misplaced the component. Then, solder the component by using solder iron and solder lead with care as shown in Figure 10. If the circuit does not working properly, troubleshoot and check the circuit until it working well. As Figure 11 shows that the 7 segment not well function and we need to troubleshoot this circuit. To make it look more proper and beautiful, we make casing for the pulse rate measurement project by using box. We place the circuit neatly on the box as shown in Figure 12.



Figure 8. Iron the PCB board



Figure 9. Etching process



Figure 10. Construct and solder component

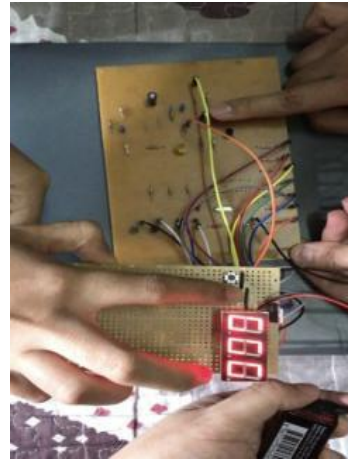

Figure 11. Troubleshoot circuit

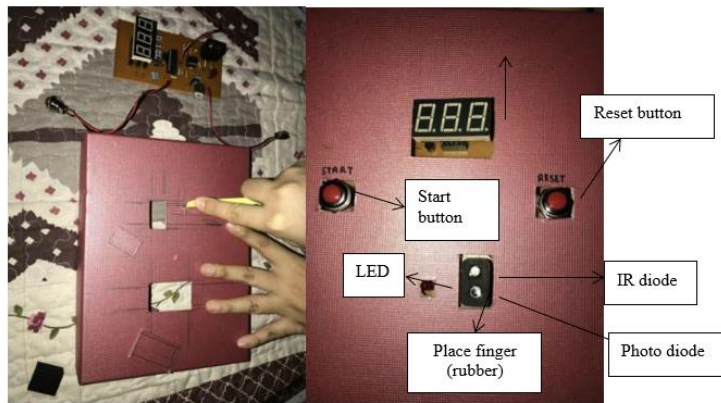

Figure 12. Casing for pulse rate measurement

3. Results and Discussions

During developing the prototype, two diodes were separated and covered by black rubber. At first, press the on switch, the prototype will initialize and the 7 segment will display 000. Next, waited until the 7 segment turn off, and put your index finger on the hole which that insert IR diode and Photodiode as shown in Figure 13 (a). The index finger will put on the IR diode and Photo diode because the index finger is so sensitive and it can easily read the pulse rate. Press the start button to start the project counted the pulse rate as shown in Figure 13 (b). Figure 13 (c) shows the pulse rate beat per minute will displayed on the 7 segment.

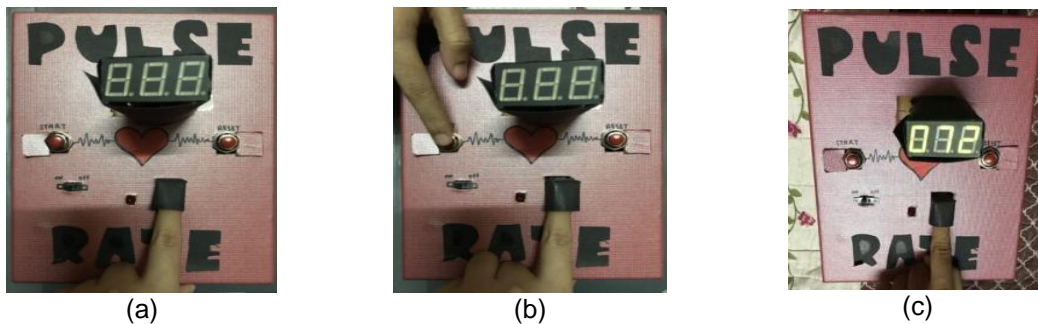

Figure 13. (a) Place finger (b) press start button (c) display result (072 BPM)

To check other person's pulse rate, press the reset button to make sure that the pulse rate before will be clear. Figure 14 shows the graph based on result Table 1 that the age of the subject and the pulse rate. For x-axis its shows the age of the subject and for y-axis its shows the pulse rate. The average for the person that have been test this pulse rate measurement project is age 19-24. The maximum pulse rate for the subject is 108 and the minimum pulse rate is 70. We can conclude that the pulse rate depend with the condition of the subject.

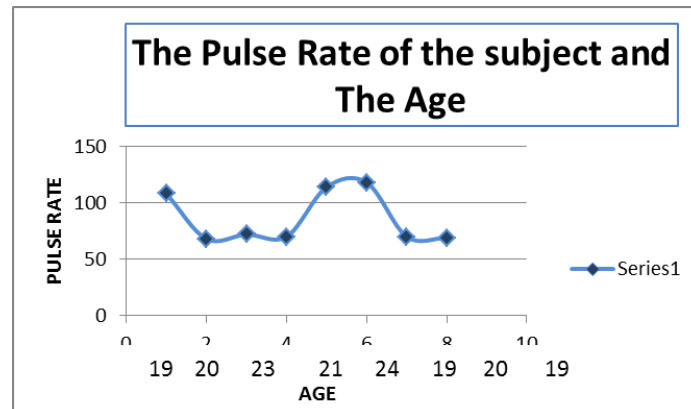

Figure 14. Graph of results for this pulse rate measurement

Table 1. Results for this Pulse Rate Measurement

Person	Gender	Age	Pulse rate	Condition
Abidah	Girl	19	108	Active
Adilah	Girl	20	68	Normal
Shazleen	Girl	23	72	Normal
Hanun	Girl	21	70	Normal
Kamal	Boy	24	114	Active
Farid	Boy	19	118	Active
Hisham	Boy	20	70	Normal
Abdullah	Boy	19	69	Normal

4. Conclusion

The pulse rate measurement was a low-cost microcontroller prototype that had been successfully built and developed. This is because; the cost of this pulse rate measurement prototype is USD 7.00. This project is very reasonable and affordable. Besides that, the project can be used at home to measure the pulse rate easily, efficient and safely without need to make an appointment with the hospital or spending a lot of money to buy existing expensive pulse rate. This work is ergonomic, portable, durable, and cost effective (reasonable and affordable).

References

- [1] http://running.competitor.com/2014/06/training/think-youre-overtraining-check-your-pulse_63593. 2018.
- [2] <http://www.advancedcardio.com/services-holter-event-monitoring.html>. 2018.
- [3] Chirakanphaisarn N, Thongkanluang T, Chiwpreechar Y. Heart rate measurement and electrical pulse signal analysis for subject's span of 20–80 years. *Journal of Electrical Systems and Information Technology*. 2016.
- [4] Barbeito A, Mark JB. Arterial and central venous pressure monitoring. *Anesthesiology Clinics of North America*. 2006; 24(4): 717-35.
- [5] <https://www.engineersgarage.com/electronic-components/7805-voltage-regulator-ic>. 2018.
- [6] <https://www.lazada.com.my/usb-pic-automatic-programming-develop-microcontroller-programmer>. 2018.

- [7] Yunus M, Talib A, Khan A. Designing a 3-lead cost effective ECG recording glove for home monitoring. *Bioscience and Engineering: An International Journal (BIOEJ)*. 2014; 1(1): 45-56.
- [8] Nims J, Capozzi M, Hailey MB, Crankson K, inventors; Nike Inc, assignee. Athletic performance monitoring system utilizing heart rate information. United States patent US 9,895,096. 2018.
- [9] Martinek R, Nedoma J, Fajkus M, Kahankova R, Konecny J, Janku P, Kepak S, Bilik P, Nazeran H. A phonocardiographic-based fiber-optic sensor and adaptive filtering system for noninvasive continuous fetal heart rate monitoring. *Sensors*. 2017; 17(4): 890.
- [10] Mallya R, Kothari S, Mehta N. *Requirements model for adaptive information system for woman health monitoring system*. 2018 International Conference on Communication information and Computing Technology (ICCICT). 2018: 1-6.
- [11] Lin Z, Chen J, Li X, Zhou Z, Meng K, Wei W, Yang J, Wang ZL. Triboelectric nanogenerator enabled body sensor network for self-powered human heart-rate monitoring. *ACS nano*. 2017; 11(9): 8830-7.
- [12] Whitfield JM, inventor. Heart rate and pulse monitoring device. United States patent application US 15/828,753. 2018.
- [13] Hussein AF, Kumar A, Burbano-Fernandez M, Ramirez-Gonzalez G, Abdulhay E, de Albuquerque VH. An Automated Remote Cloud-Based Heart Rate Variability Monitoring System. *IEEE Access*. 2018; 6: 77055-77064.
- [14] Cadmus BL, Gangnon R, Wirkus EJ, Thraen BKM, Gorzelitz LJ. The accuracy of heart rate monitoring by some wrist-worn activity trackers. *Annals of internal medicine*. 2017; 166(8): 610-2.
- [15] Kocabas O, Soyata T, Couderc JP, Aktas M, Xia J, Huang M. *Assessment of cloud-based health monitoring using homomorphic encryption*. 2013 IEEE 31st International Conference on Computer Design (ICCD). 2013: 443-446.
- [16] Yang Z, Zhou Q, Lei L, Zheng K, Xiang W. An IoT-cloud based wearable ECG monitoring system for smart healthcare. *Journal of medical systems*. 2016; 40(12): 286.
- [17] Hassanaliyeragh M, Page A, Soyata T, Sharma G, Aktas M, Mateos G, Kantarci B, Andreescu S. *Health monitoring and management using Internet-of-Things (IoT) sensing with cloud-based processing: Opportunities and challenges*. 2015 IEEE International Conference on Services Computing. 2015: 285-292.
- [18] Bourouis A, Feham M, Bouchachia A. A new architecture of a ubiquitous health monitoring system: a prototype of cloud mobile health monitoring system. arXiv preprint arXiv:1205.6910. 2012.
- [19] Chen M, Ma Y, Li Y, Wu D, Zhang Y, Youn CH. Wearable 2.0: Enabling human-cloud integration in next generation healthcare systems. *IEEE Communications Magazine*. 2017; 55(1): 54-61.
- [20] Jindal V. *Integrating mobile and cloud for PPG signal selection to monitor heart rate during intensive physical exercise*. Proceedings of the International Conference on Mobile Software Engineering and Systems. 2016: 36-37.
- [21] Babu S, Chandini M, Lavanya P, Ganapathy K, Vaidehi V. *Cloud-enabled remote health monitoring system*. 2013 International Conference on Recent Trends in Information Technology (ICRTIT). 2013: 702-707.
- [22] Melillo P, Orrico A, Scala P, Crispino F, Pecchia L. Cloud-based smart health monitoring system for automatic cardiovascular and fall risk assessment in hypertensive patients. *Journal of medical systems*. 2015; 39(10): 109.
- [23] Alam MG, Cho EJ, Huh EN, Hong CS. *Cloud based mental state monitoring system for suicide risk reconnaissance using wearable bio-sensors*. Proceedings of the 8th International Conference on Ubiquitous Information Management and Communication. 2014: 56.
- [24] Sailunaz K, Alhussein M, Shahiduzzaman M, Anowar F, Al Mamun KA. CMED: Cloud based medical system framework for rural health monitoring in developing countries. *Computers & Electrical Engineering*. 2016; 53: 469-481.
- [25] Tan L. Cloud-based decision support and automation for precision agriculture in orchards. *IFAC-PapersOnLine*. 2016; 49(16): 330-335.