

## Fault Tolerant Air Bubble Sensor using Triple Modular Redundancy Method

Noor Cholis Basjaruddin<sup>1,2</sup>, Yoga Priyana<sup>1</sup>, Kuspriyanto<sup>1</sup>

<sup>1</sup>School of Electrical Engineering and Informatics, Bandung Institute of Technology  
Jl. Ganesha no. 10, Bandung, Indonesia

<sup>2</sup>Department of Electrical Engineering, Politeknik Negeri Bandung  
Jl. Gegerkalong Hilir, Ds.Ciwaruga Kotak Pos 1234 Bandung 40012, Phone: +62-22-2013789  
e-mail: ppmteam@gmail.com

### Abstrak

Pendeteksian gelembung udara dalam darah adalah penting untuk berbagai tindakan medis yang menggunakan Extracorporeal Blood Circuits (ECBC), seperti hemodialisis, hemofiltrasi, dan cardiopulmonary bypass. Oleh karena itu diperlukan pendeteksi gelembung udara yang handal. Pada penelitian ini dirancang pendeteksi gelembung udara yang kebal terhadap kesalahan (fault tolerant). Metoda Triple Modular Redundancy (TMR) digunakan pada bagian sensor. Bagian voter pada Triple Modular Redundancy akan memilih salah satu keluaran dari tiga keluaran sensor untuk diproses selanjutnya. Penerapan Triple Modular Redundancy akan mencegah kesalahan dalam pendeteksian gelembung udara terutama jika sensor gagal bekerja.

**Kata kunci:** deteksi gelembung udara, triple modular redundancy, extracorporeal blood circuits

### Abstract

Detection of air bubbles in the blood is important for various medical treatments that use Extracorporeal Blood Circuits (ECBC), such as hemodialysis, hemofiltration and cardio-pulmonary bypass. Therefore a reliable air bubble detector is needed. This study presents the design of a new fault tolerant air bubble detector. Triple Modular Redundancy (TMR) method is used on the sensor section. A voter circuit of the Triple Modular Redundancy will choose one of three sensor outputs to be processed further. Application of Triple Modular Redundancy will prevent errors in the detection of air bubbles, especially if the sensor fails to work.

**Keywords:** air bubble detector, triple modular redundancy, extracorporeal blood circuits

### 1. Introduction

We currently experience rapid development of technology in all areas, including to the technology used in a variety of medical treatments. Equipment used in hemodialysis, hemofiltration or cardio-pulmonary bypass requires the detection of air bubbles in the blood. The presence of air bubbles in the blood can cause local reactions such as tissue ischemia or necroses which sometimes can be fatal for the patient.

Air bubbles contained in the extracorporeal generally appear during the installation of the appliance. In addition, air bubbles can be formed by a blood pump, blood flow turbulence in the tubing and at the vascular access, as well as due to differences in temperature.

Micro air bubbles are currently recognized as a medical hazard in cardiac surgery. The entry of micro air bubbles into the venous or arterial system can be fatal. Venous emboli may lead to cardiovascular collapse or to paradoxical arterial emboli. Arterial emboli may occlude end arteries throughout the body and may cause serious diseases or death if they occlude cardiac or cerebral vessels.

Air bubble detection techniques can use infrared sensors, ultrasonic sensors [1] or capacitor sensors. Sensors with high reliability needed for detection of air bubbles can work reliably. Triple Modular Redundancy (TMR) is one of fault tolerant methods that can be used to improve the sensor reliability [2]. Three sensors are used in TMR to measure the physical quantities. Damage to one of the sensors will not be fatal to the TMR system.

## 2. Research Method

### 2.1. Capacitive Air Bubble Sensor

Characteristics of capacitive sensor from other research [3] is shown in Table 1.

Table 1. Measured capacitance and voltage for different air bubble diameters

Capacitance (nF)	Air Bubbles Diameter (mm)	Output Voltage (mV)
43.50	0	18.60
42.63	0.82	20.30
42.54	1.00	22.01
41.07	2.97	40.50
40.44	3.55	43.70
39.38	4.00	47.90

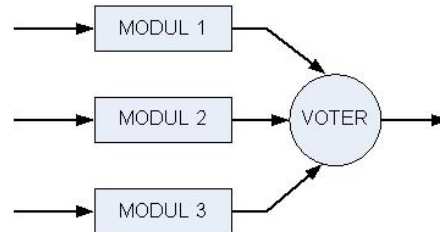

Figure 1. Triple modular redundancy

### 2.2. Triple Modular Redundancy (TMR)

Triple Modular Redundancy (TMR) is a fault tolerant method using three modules (sensors, actuators, or processors) that work together and get the same input signal. Output of TMR is one of the three output chosen with voting techniques. Block diagram of TMR is shown in Figure 1.

### 2.3. Redundant Sensor Using TMR

Redundant sensors to improve the system reliability can be realized by various methods. The simplest method is to use two sensors, one primary sensor and a backup sensor. Redundant complex sensors can be realized by using many sensors in a matrix (sensor array). In this study a redundant sensor using TMR is developed. Block diagram of the system being developed can be seen in Figure 2.

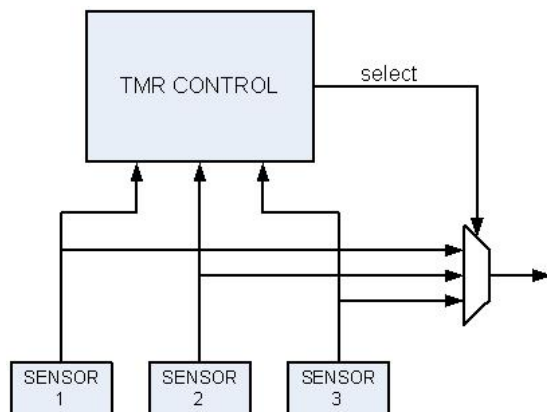

Figure 2. Redundant sensor using TMR method

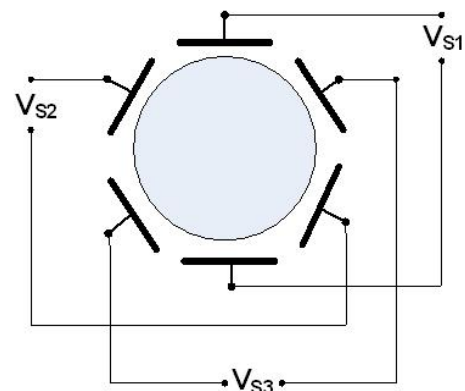

Figure 3. Installation of three capacitive sensors

### 2.4. Sensor Installation

Use of TMR on redundant sensors requires the three sensors that are ideally equal and installed such that the three sensors measure the same magnitude in the same time. Example installation of sensors that meet these conditions can be seen in Figure 3. The figure shows three capacitive sensors mounted around the tube to measure air bubbles.

**2.5. Voting Technique**

Determination of the redundant sensor output of three sensor output is called voting. Voting techniques commonly used in TMR are majority vote, mid-value vote, and the mean value vote. In the majority vote, output is selected from at least two same sensor outputs. So if a sensor fails or is not functioning properly, the sensor output is selected based on two other sensor outputs. In the mid-value voting techniques, the selected sensor output is the middle value (median) of the three sensor output values [4]. The selected sensor output can also be based on the average value of all sensor outputs, this technique is known as the mean value technique.

The mid-value voting technique is selected in this research. The consideration of this technique is easily implemented in the analog circuit.

**2.6. Mid Value Determination**

Determination of the mid value of three sensor outputs done in hardware with analog components. The use of analog components can save the cost of implementation because the sensor output generally uses analog signals. In addition, the use of analog components can reduce the error caused by the digitalization process in digital circuit.

The electronic circuit to determine the mid value divided into two main sections. The first section is the comparator and the second is a multiplexer.

**2.6.1. Comparator Section**

Three voltage comparator circuits with the op-amp as main components are used in this section. Figure 4 shows a voltage comparator circuit. Figure 5 shows the block diagram of comparator section.

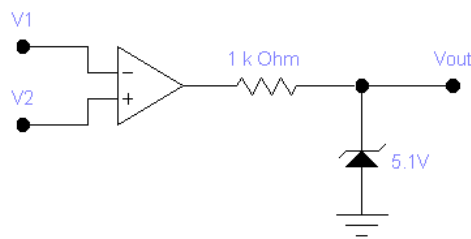

$V1 < V2, Vout = 1$   
 $V1 > V2, Vout = 0$

Figure 4. Voltage comparator circuit

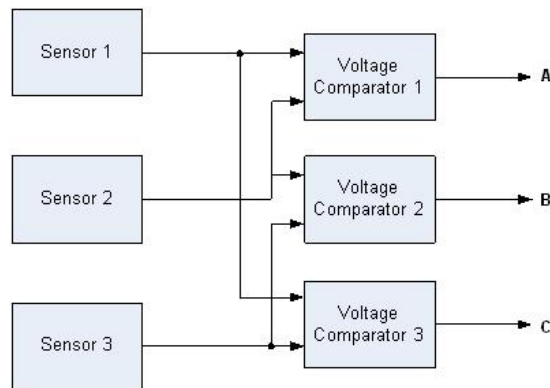

Figure 5. Block diagram of comparator

In Figure 5, A, B, and C are the result of comparisons between the output of sensors 1 and 2, 2 and 3, and 1 and 3. A, B, and C for various conditions is shown in Table 2.

Table 2. Output of comparator section.

Inputs	A	B	C
$V_{S1} < V_{S2}$	0	-	-
$V_{S1} > V_{S2}$	1	-	-
$V_{S2} < V_{S3}$	-	0	-
$V_{S2} > V_{S3}$	-	1	-
$V_{S1} < V_{S3}$	-	-	0
$V_{S1} > V_{S3}$	-	-	1

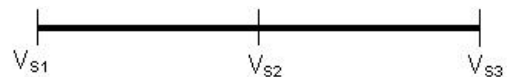

Figure 6. Mid value of sensor output

Based on Table 2, the redundant sensor output can be determined from the mid value. For example if  $A = 0, B = 0,$  and  $C = 0,$  meaning  $V_{S1} < V_{S2}, V_{S2} < V_{S3},$  dan  $V_{S1} < V_{S3}.$  Figure 6 shows an illustration of this condition.

$V_{S2}$  is the mid value of three sensor outputs. Table 3 shows the results of the sensor output selection by using the mid value voting.

**2.6.2. Multiplexer Section**

This section serves to process the output of comparator section to be used to determine the selected sensor output in hardware. Multiplexer designed by referring to Table 4 which is a truth table result of the development of Table 3.

Table 3. Sensor selection.

A	B	C	Sensor Selected
0	0	0	S2
0	0	1	none
0	1	0	S3
0	1	1	S1
1	0	0	S1
1	0	1	S3
1	1	0	none
1	1	1	S2

Table 4. Truth table of multiplexer.

A	B	C	SM1	SM2	SM3
0	0	0	0	1	0
0	0	1	-	-	-
0	1	0	0	0	1
0	1	1	1	0	0
1	0	0	1	0	0
1	0	1	0	0	1
1	1	0	-	-	-
1	1	1	0	1	0

A value of 1 in columns SM1, SM2, SM3 means output sensor of S1, S2, or S3 was selected as the mid value.

Based on Table 4 can be made a multiplexer with 3 inputs and 3 outputs. Three outputs of this multiplexer can be used to control the selector circuit. Figure 7 shows the block diagram of a multiplexer.

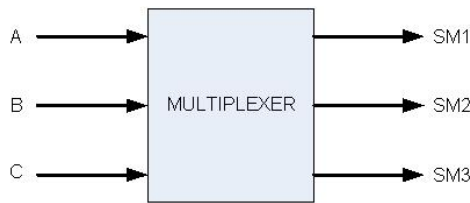

Figure 7. 3-to-3 multiplexer

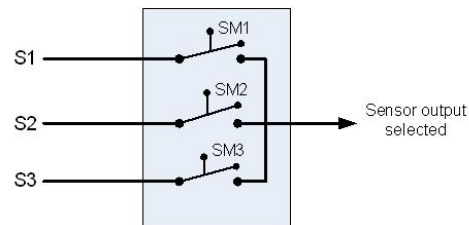

Figure 8. Block diagram of voter

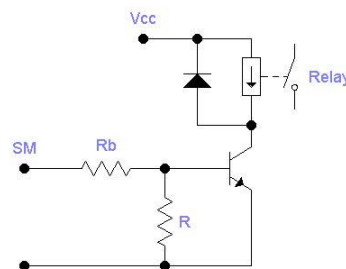

Figure 9. Transistor As Switch

**2.7. Voter Circuit (Selector Circuit)**

The voter circuit composed of three transistors that function as switches. Figure 8 shows the block diagram of voter and Figure 9 shows the transistor as a switch that can be operated by providing logic zero or one on the input. If logic 1 is given at the input, the transistor will be on, and output of a sensor will be selected for further processing.

**3. Results and Analysis**

**3.1. Simulation of Mid Value Determination**

Figure 10 shows result of mid value determination simulation.

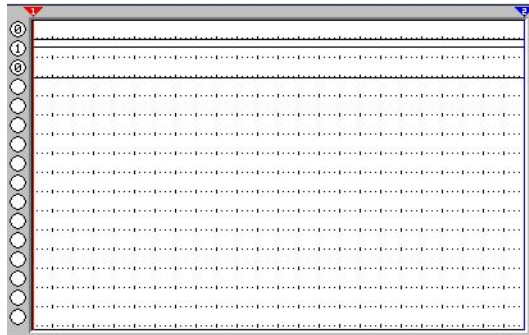

Figure 10. Output A, B, and C of comparator are 0, 1, and 0 so sensor 3 (S3) is selected in mid value determination simulation

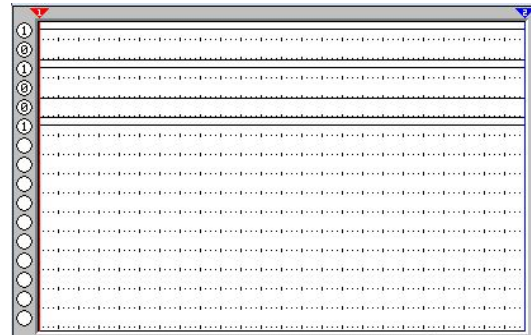

Figure 11. Outputs of multiplexer are 001 (three bottom curves) if 101 as inputs (three topmost curves) when sensor 3 (S3) is selected.

This simulation shows that the determination of the mid value can be done by using 3 voltage comparators. In this case, output A, B, and C of comparator are 0, 1, and 0. Refer to Table 3, sensor 3 (S3) is selected.

**3.2. Multiplexer Simulation**

Figure 10 shows one of the simulation results with the input multiplexer 101 and output 001 (sensor 3 selected). Multiplexer in this simulation using three NOT gates, six AND gates and three OR gates.

**3.3. Simulation of Voter Circuit**

Figure 11 shows the results of voter circuit simulation. At the beginning of this simulation, the redundant sensor output is the output of sensor 2. Sensor output which selected is the mid value of the entire sensor outputs. At 6 second, sensor 2 (S2) output increased and greater than sensor 1 (S1) output. Now, sensor 1 output become mid value and selected as redundant sensor output. This simulation shows that the voter circuit can function properly.

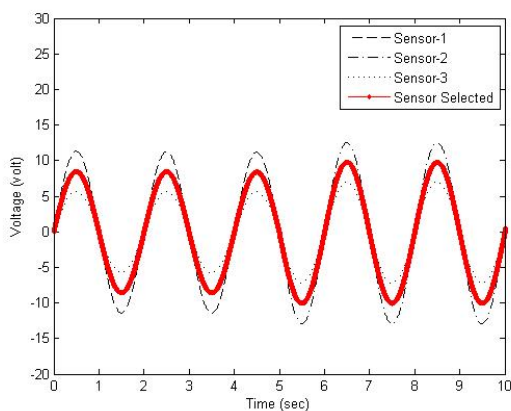

Figure 12. Result of voter circuit simulation

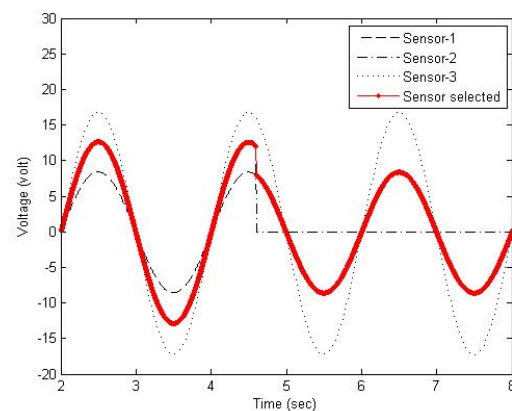

Figure 13. Simulation circuit voters

### 3.4. Simulation of Sensor Failure

In this simulation the sensor 2 (S2) damage experience. In Figure 12 it can be seen that at about 4.6 sec, sensor 2 fails to works, consequently voter must choose another sensor output. In this case sensor 1 (S1) is selected. This simulation shows that the reliability of systems using redundant sensors is higher than without the use of redundant sensors.

In simulation 3.3 and 3.4, a difference three sensor outputs deliberately large. Simulation is done with the help of software Electronics Workbench (EWB) and the results are then processed with Matlab software.

### 3.5. System Reliability

Use of TMR on redundant sensors will increase system reliability. Failure in this system occurs when two or more sensors damaged. When only one sensor fails to work then the system can still work. Reliability of redundant sensors can be compared with the reliability of a sensor with a assumption that the voter circuit has no damage.

In this research, a markov model is used for realibility analysis. Two sensor conditions are good (G) and fail (F). For six sensors, that conditions are 1G, 1F, 2G, 2F, 3G and 3F. Notation 1G means sensor 1 is good. States of fault tolerant sensor systems are:

- State 1 (ST1) : 1G2G3G
- State 2 (ST2) : 1F2G3G or 1G2F3G or 1G2G3F
- State 3 (ST3) : 1G2F3F or 1F2G3F or 1F2F3G
- State 4 (ST4) : 1F2F3F

If every sensor has failure rate  $\lambda$ , then probability of transition to fail state is  $\lambda \cdot \Delta t$ . For sensor 1, 2, and 3 are  $\lambda_1 \cdot \Delta t$ ,  $\lambda_2 \cdot \Delta t$ , and  $\lambda_3 \cdot \Delta t$ . A markov model for fault tolerant sensor is shown at Figure 14.

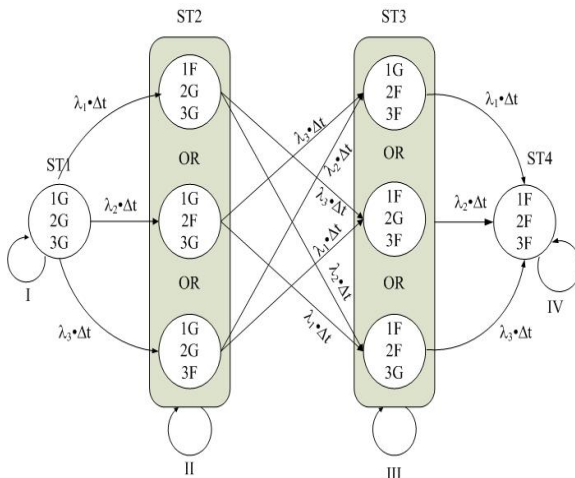

Figure 14. Markov model for fault tolerant sensor

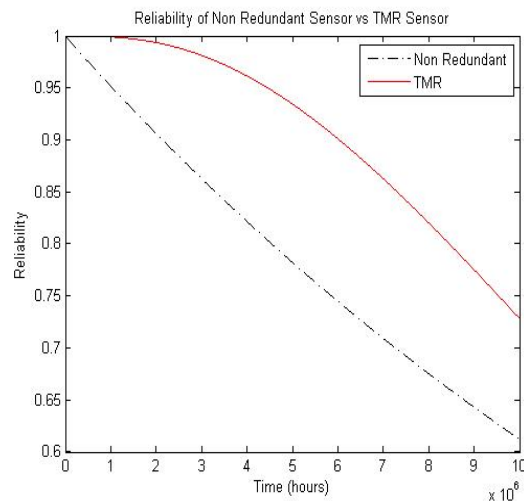

Figure 15. Reliability curve of fault tolerant sensor and single sensor

#### 3.5.1. The Probability of Being in State ST1

$$P1(t+\Delta t) = P1(t) \cdot [1 - \lambda_A \Delta t] \tag{1}$$

where

$$\lambda_A = \lambda_1 + \lambda_2 + \lambda_3$$

### 3.5.2. The Probability of Being in State ST2

$$P2(t+\Delta t) = P1(t) \cdot \lambda_A \Delta t + P2(t) \cdot [1 - \lambda_B \Delta t] \quad (2)$$

where

$$\lambda_B = 2\lambda_1 + 2\lambda_2 + 2\lambda_3$$

### 3.5.3. The Probability of Being in State ST3

$$P3(t+\Delta t) = P2(t) \cdot \lambda_B \Delta t + P3(t) \cdot [1 - \lambda_C \Delta t] \quad (3)$$

where

$$\lambda_C = \lambda_1 + \lambda_2 + \lambda_3$$

### 3.5.4. The Probability of Being in State ST4

$$P4(t+\Delta t) = P3(t) \cdot \lambda_C \Delta t + P4(t) \quad (4)$$

Rearranging the equations:

$$\begin{aligned} [P1(t+\Delta t) - P1(t)]/\Delta t &= -\lambda_A \cdot P1(t) \\ [P2(t+\Delta t) - P2(t)]/\Delta t &= \lambda_A \cdot P1(t) - \lambda_B \cdot P2(t) \\ [P3(t+\Delta t) - P3(t)]/\Delta t &= \lambda_B \cdot P2(t) - \lambda_C \cdot P3(t) \\ [P4(t+\Delta t) - P4(t)]/\Delta t &= \lambda_C \cdot P3(t) \end{aligned}$$

Taking the limit as  $\Delta t \rightarrow 0$

$$\begin{aligned} dP1(t)/dt &= -\lambda_A \cdot P1(t) \\ dP2(t)/dt &= \lambda_A \cdot P1(t) - \lambda_B \cdot P2(t) \\ dP3(t)/dt &= \lambda_B \cdot P2(t) - \lambda_C \cdot P3(t) \\ dP4(t)/dt &= \lambda_C \cdot P3(t) \end{aligned}$$

In matrix form this becomes:

$$\begin{bmatrix} dP1(t)/dt \\ dP2(t)/dt \\ dP3(t)/dt \\ dP4(t)/dt \end{bmatrix} = \begin{bmatrix} -\lambda_A & 0 & 0 & 0 \\ \lambda_A & -\lambda_B & 0 & 0 \\ 0 & \lambda_B & -\lambda_C & 0 \\ 0 & 0 & \lambda_C & 0 \end{bmatrix} \begin{bmatrix} P1(t) \\ P2(t) \\ P3(t) \\ P4(t) \end{bmatrix} \quad (5)$$

We assume failure rate of a capacitive air bubble sensor is 0.049 failures/10<sup>6</sup> hours (Military Handbook MIL-HDBK-217F, Notice 2). Transition matrix (5) is used in simulation and result of simulation is shown in Figure 14. Figure 14 shows TMR sensor is more reliable than non redundant sensor.

### 3.6. Sensor Accuracy

In addition to increase reliability, redundant sensors also increase the accuracy of the sensor. In Figure 11 can be seen that the sensor output of three selected single sensor output which is the mid value. Selection of the sensor output which is the mid value can increase accuracy of the redundant sensor. When the sensor output suddenly increases, for example in Figure 11 this occur at the output of sensor 2, then the output from the selected sensor is replaced with another. This mechanism will prevent the system from sensor readings that are incorrect or in other words increase accuracy.

#### 4. Conclusion

The detection of air bubbles at medical devices is very important. Reliability of air bubble detectors can be improved by increasing the reliability of the sensor section. One fault tolerant method that can be used to improve the reliability of the sensor is Triple Modular Redundancy.

A redundant sensor using Triple Modular Redundancy configuration can improve system reliability. Selection of the sensor output by using the mid value technique can be implemented in hardware using analog and digital components. In addition to improving reliability, redundant sensors with Triple Modular Redundancy configuration also increase the accuracy of the sensor.

#### References

- [1] Johnson et.al. Method and Apparatus for Ultrasonic Detection of Air Bubbles. *United States Patent*. 1995.
- [2] Zhao WS, Devolder T, Lakys Y, Klein JO, Chappert C, and Mazoye P. Design Considerations and Strategies for High-Reliable STT-MRAM. *Microelectronics Reliability*. 2011; 51: 1454–1458.
- [3] Mawahib Gafare Abdalrahman Ahmed, Abdallah Belal Adam, John Ojur Dennis, and Gail Sylvia Steele. Capacitor Device for Air Bubbles Monitoring. *International Journal of Electrical & Computer Sciences IJECS*. 2009; 9(10): 12-15.
- [4] M. D. Krstic, M. K. Stojcev, G. Lj. Djordjevic, and I. D. Andrejic. A Mid-Value Select Voter. *Microelectronics and Reliability*. 2005; 45(3-4): 733-738.
- [5] Akram U, Jamal I, Tariq A. Blood Vessel Enhancement and Segmentation for Screening of Diabetic Retinopathy. *TELKOMNIKA*. 2012; 10(2): 327-334.
- [6] Barak, M., and Katz, Y. Microbubbles Pathophysiology and Clinical Implications. *Chest*. 2005; 128: 2918- 2932.
- [7] Carl Carmichael. Triple Module Redundancy Design Techniques for Virtex FPGAs. *XAPP197 (v1.0.1)*. 2006.
- [8] Georg Brasseur. Design Rules for Robust Capacitive Sensors. *IEEE Transactions on Instrumentation and Measurement*. 2003; 52(4): 1261-1265.
- [9] Mark Stringham, B.S., M.S., P.E. Reliability Analysis of Moog Ultrasonic Air Bubble Detectors. Moog, Inc. 2009.
- [10] Mawahib Gafare Abdalrahman, Abdallah Bellal Adam, and John Ojur Dennis. *Capacitive Air Bubble Detector for Moving Blood in Artificial Kidney*. The 3<sup>rd</sup> International Symposium on Biomedical Engineering (ISBME 2008). 2008.
- [11] Mawahib Gafare Abdalrahman, Abdallah Bellal Adam, and John Ojur Dennis. Capacitive Air Bubble Detector Operated at Different Frequencies for Application in Hemodialysis. *World Academy of Science, Engineering and Technology* 50. 2009.
- [12] Munir A and Gordon-Ross A. Markov Modeling of Fault-Tolerant Wireless Sensor Networks. *IEEE International Conference on Computer Communications and Networks (ICCCN 2011)*. 2011.
- [13] Namazi A, Askari S, and Nourani M. Highly Reliable A/D Converter Using Analog Voting. *IEEE*. 2008
- [14] Richard Spillman. Lecture 26 – Alternative Architectures. Pacific Lutheran University.
- [15] Ruzairi Abdul Rahim, Ng Wei Nyap, Mohd Hafiz Fazalul Rahiman, and Chan Kok San. Determination of Water and Oil Flow Composition Using Ultrasonic Tomography. *Elektrika*. 2007; 9(1): 19-23.
- [16] Tama BA, Rodiyatul FS, Hermansyah. An Early Detection Method of Type-2 Diabetes-Mellitus in Public Hospital. *TELKOMNIKA*. 2011; 9(2): 287-294.