

# Controlling a knee CPM machine using PID and iterative learning control algorithm

Dechrit Maneetham<sup>1</sup>, Petrus Sutiyasadi<sup>2</sup>

<sup>1</sup>Mechatronics, Rajamangala University of Technology Thanyaburi, Thailand

<sup>2</sup>Mechatronics, Politeknik Mekatronika Sanata Dharma, Indonesia

## Article Info

### Article history:

Received Jul 18, 2019

Revised Dec 30, 2019

Accepted Feb 14, 2020

### Keywords:

CPM

ILC

Learning algorithm

PID

Rehabilitation machine

## ABSTRACT

A conventional continuous passive motion (CPM) machine uses simple controller such as On/Off controller. Some better CPMs use PID controller. These kind of CPMs can not distinguish load different due to the different size of the patient leg. This may cause the CPM no longer follow the trajectory or the angle commands. Meanwhile, each patient may have different scenario of therapy from the others. When progress on the patient exists, the range of the flexion may be increased step by step. Therefore, the treatment can be different in term of the range of flexion from time to time. This paper proposes CPM with hybrid proportional integral derivative (PID) and iterative learning controller (ILC). The system has capability in learning the trajectory tracking. Therefore, the CPM will be able to follow any load or trajectory changes applied to it. The more accurate CPM machine can follow the trajectory command, the better its performance for the treatment. The experiment showed that the system was stable due to the PID controller. The tracking performance also improved with the ILC even there exist some disturbances.

*This is an open access article under the [CC BY-SA](https://creativecommons.org/licenses/by-sa/4.0/) license.*



## Corresponding Author:

Dechrit Maneetham,

Faculty of Technical Education, Mechatronics Engineering,

Rajamangala University of Technology Thanyaburi,

Rangsit-Nakhon Nayok Rd, Khlong Hok, Khlong Luang District, Pathum Thani, Thailand.

Email: [dechrit\\_m@rmutt.ac.th](mailto:dechrit_m@rmutt.ac.th)

## 1. INTRODUCTION

A continuous passive motion (CPM) machine is a mechanism that works according to rehabilitation theory of a continuous and repetitive passive motion [1]. This movement has the purpose in medical practice to recover injured limbs motoric function [2]. the function of a CPM is it may reduce the therapist's workload at the hospital [3]. CPM is expected can be programmed to do a repetitive movement in flexing and bending the patient's muscle.

Some accidents on the knee may cause problem in the anterior cruciate ligament (ACL). The accidents usually make strong impact or hyperextension. In this case, sometimes surgical reconstruction of the ACL must be conducted [4]. ACL injuries are common for some active people [5]. ACL is the most important component for the knee movement. The main function of ACL is to control posterior translation of the femur when the tibia is fixed [6]. Patient with ACL rupture usually need a surgical treatment using tissue autografts or allografts [7] to restore the pivoting spots [8].

After the surgery, early treatment that usually conducted is passive rehabilitation to minimize swelling and pain, but mostly to bring back the range of motion. Passive rehabilitation is moving the limbs while the muscle remains relax. If it is not done by a therapist, it can be done by a CPM machine [9]. According to

some researches, by using CPM machine, significant range of motion gain from 7 to 22 degrees has been reported [10–16]. Another reported that during the hospital stay, CPM machine increase the speed of knee flexion recovery [16-19].

Some CPM machine use On/Off control. However, some researchers using proportional integral and derivative (PID) controller, a linear and simple controller to control the CPM machine [20-22]. To handle the non-linear dynamics of the CPM, PID with Neural Network algorithm was also proposed [23]. However, variation of loads may affect the trajectory tracking of the CPM. Iterative learning control (ILC) is a relatively new algorithm that is able to learn and fix a trajectory tracking control problem of a repetitive works [24-26]. CPM machine works in repetitive way. This paper explains the development of a knee CPM machine and its control algorithm using PID-ILC. The goal is having a knee CPM with capability to track the trajectory reference in the presence of various load from the patient's leg.

## 2. RESEARCH METHOD

A knee CPM machine was designed and manufactured for the prototype. The machine was actuated by a dc motor. To control the motor, a PID-ILC controller was developed and implemented to the system. The mechanical, electronic, and the controller design are explain in this chapter.

### 2.1. Mechanical design

The structure is made from stainless steel and aluminium. The drawing of the design is shown in Figure 1. The 3D design of the CPM prototype is shown in Figure 2. The final result of the hardware is shown in Figure 3. The controller and the dc motor driver including the adaptor are put in one box. The the shank support has sponge and covered with vinyl sheet. It also has vinyl strap to hold the patient leg during machine operation. In this case we measure and control the angle of the hip joint (b). The angle was measured from the conversion of the encoder value. Figure 4 shows the hardware test on an adult's leg. It shows also the ratio or the proportion of the hardware size to an adult's leg. The straps used to hold the leg so it can follow the CPM movement.

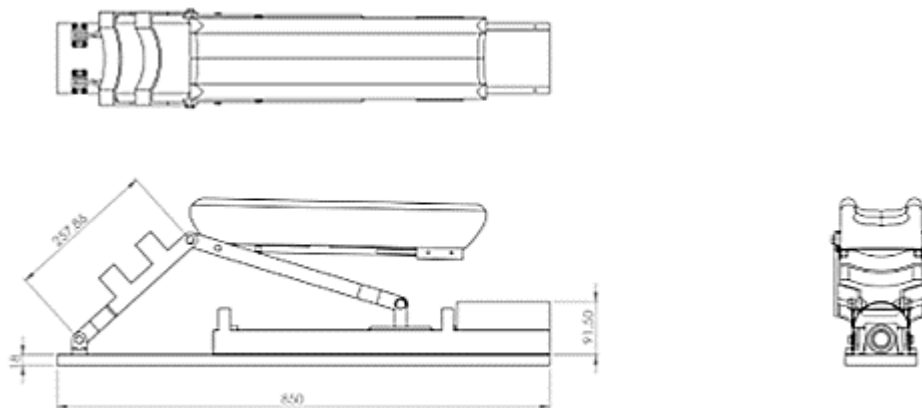

Figure 1. Mechanical design of the CPM (dimension in mm)

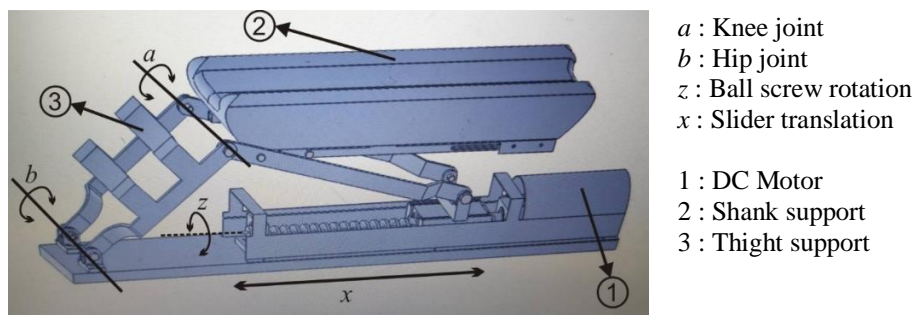

Figure 2. Three dimensional drawing of the CPM



Figure 3. CPM Prototype



Figure 4. Leg test on the CPM

## 2.2. Electronic design

The CPM movement is generated by a rotational movement produced by a DC motor. By using a crank slider mechanism, the rotational movement is translated into linear motion. The rotation of the motor is read by using a rotary encoder attached directly to the dc motor shaft at the back. The information of the actual position of the motor is sent to the microcontroller. The position information then will be compared to the trajectory defined and then the error will be manipulated using proportional, integral, and derivative term inside the PID controller. The performance along the trajectory was recorded. The performance in each particular point of the quantized trajectory is compared to the previous one and manipulated using proportional and derivative term inside the ILC controller. The manipulated variable from the ILC was sent and add up to the PID output. The correction signal from the ILC will refine the control signal of the PID. The controller uses Arduino UNO board, and the DC motor driver uses VN12SP chip that has many advantages such as polarity, over voltage, and over current protection. The detail of the electronic diagram is shown on Figure 5.

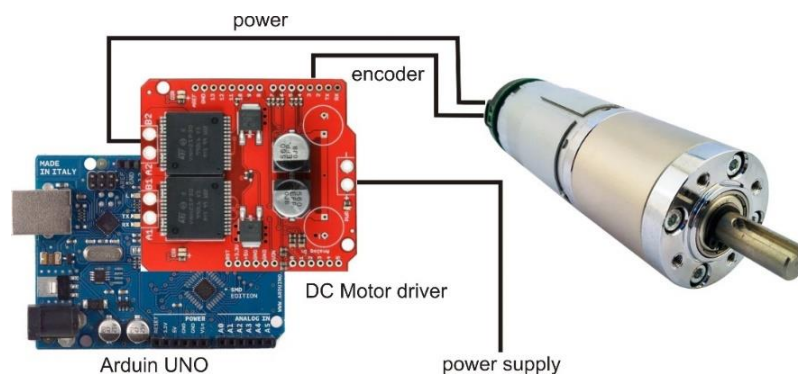

Figure 5. Electronic diagram of the dc motor control

### 2.3. PID and ILC controller design

Proportional Integral and Derivative (PID) controller was invented in 1910, owned by Elmer Sperry's ship autopilot. The popularity of the controller even grown more since the tuning methods was introduced by Ziegler and Nichols in 1942 [27-28]. PID controller is a controller that calculates the difference between the desired values or Set Point (SP) to the actual value or the output. The difference between SP and output is called the error signal. The error signal then to be processed based on proportional, integral, and derivative terms to get the manipulated variable or the control signal. However, despite of its popularity, even PID controller only consist of three gain to be tuned, it still hard to do. There are still a large number of badly tuned PID controllers on a process plant [29].

Iterative Learning Control (ILC) is a controller that improves the trajectory tracking by leaning from previous task. The previous task means a complete tracking of the whole trajectory from start to end. The conditions that should be fulfilled before using the ILC are:

- It is a repetitive work on a same trajectory.
- The starting and ending position should be the same.
- The system should be stable.

The accuracy of the tracking is improved from one repetition to the next repetition. The system should be a stable system before the ILC is implemented. This is done by the PID controller. In combining PID and ILC then the PID gains should be set to low values but stable. Even the tracking is poor due to the low gain, ILC will adjust the manipulated control signal until the desired trajectory is achieved [30]. Control signal of ILC is determined from

$$u_j = u_{j-1} + k_d \dot{e}_{j-1}(t) + k_p e_{j-1}(t) \quad (1)$$

the hybrid PID-ILC is formed by adding signal from ILC to the PID algorithm. Thus, the controller becomes:

$$u_{PID} = k_p e_j(t) + k_d \dot{e}_j(t) + k_i \int e_j(t) dt + u_j \quad (2)$$

with the variables are:

- $u_j$  : ILC control signal,
- $e_j$  : error signal,
- $j$  : iteration number,
- $k_p$  : proportional gain,
- $k_d$  : derivative gain,
- $k_i$  : integral gain.

The block diagram of the PID-ILC controller is shown in Figure 6.

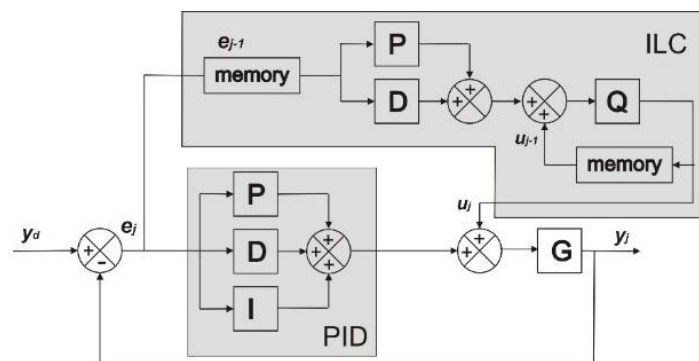

Figure 6. Block diagram of hybrid PID-ILC

### 3. RESULTS AND ANALYSIS

The CPM was given a triangle wave trajectory input. The variables being controlled are the amplitude of the wave that indicates the angle of the hip joint on the CPM. The PID constant setting is usually done when the CPM has no load on it. Loads may disturb the control system of the CPM. Additional load from patient's leg can change the trajectory tracking response. Theoretically Iterative Learning Control fixes the trajectory tracking within particular time in repetitive way. Figure 7 shows from the experiment that even the PID

controller has been tuned properly, but some load applied have changed the trajectory tracking. It did not affect much on the rise time, but the steady state error was increased significantly. The amplitude reduced 6 degrees. Three degrees less from the maximum position and three degrees from the minimum position.

Figure 8 shows that PID-ILC controller is able to return the trajectory tracking to the trajectory reference. On the first repetition, the PID-ILC produced small overshoot, but later it was able to manage the oscillation to meet the trajectory reference. After four repetitions, the system was able to return to the trajectory reference. Another experiment is with lower PID constant gains set. In the beginning, the system could not track the trajectory reference. However, after several iteration, the system was able to track the trajectory even with initial low PID gain. Figure 9 shows the system response with PID control only and the gains were set low. There are steady state errors. Figure 10 shows combining with ILC, the PID controller after seven iterations the system was able to track the trajectory reference.

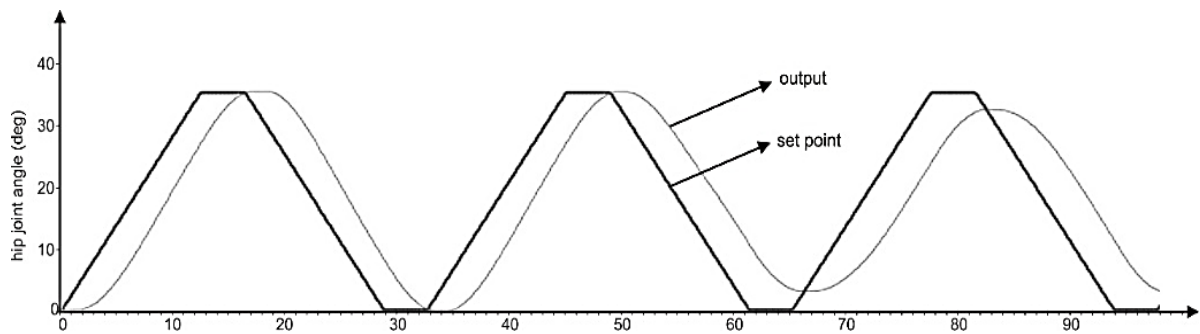
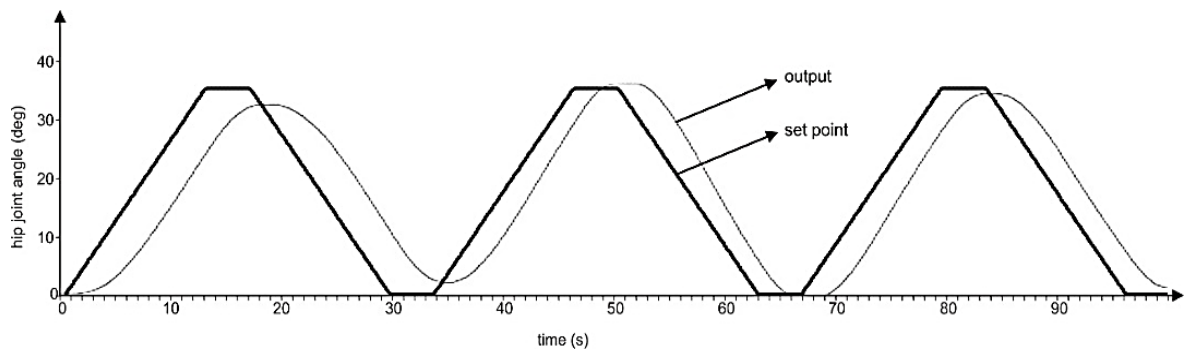
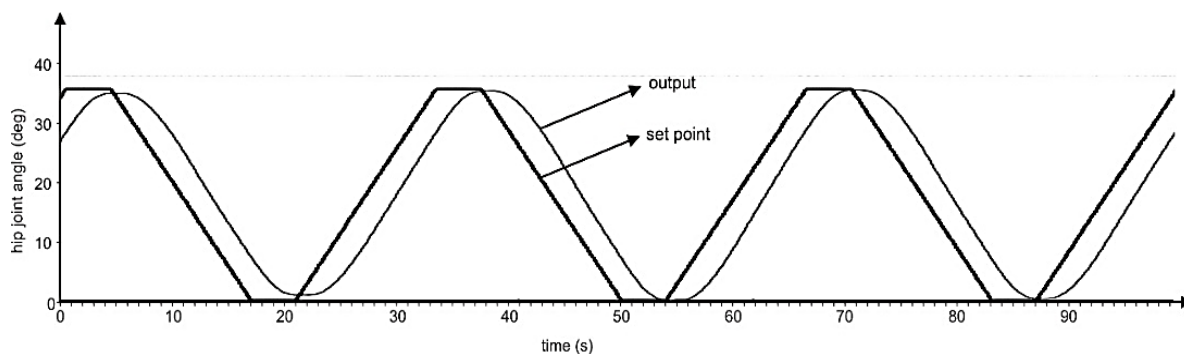

Figure 7. Load changes trajectory tracking of a well tuned PID controller



(a)



(b)

Figure 8. (a) PID-ILC controller tracked back the trajectory reference after disturbance, (b) after four repetitions PID-ILC perfectly track the trajectory reference



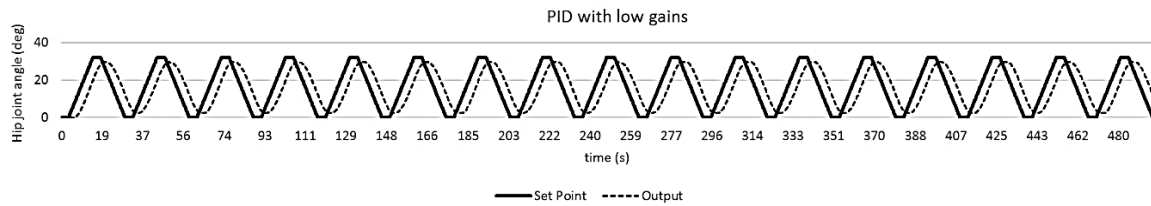

Figure 9. PID controller with low gains

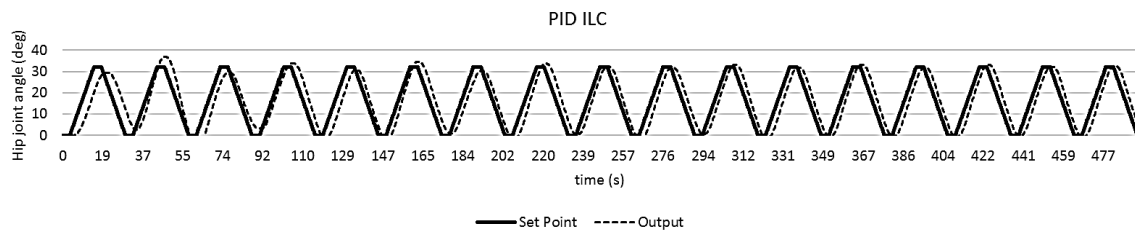

Figure 10. PID-ILC response system

#### 4. CONCLUSION

The CPM machine has been developed and controlled successfully using PID-ILC controller. The mechanical part is able to support the patient leg. All the joints movement are smooth. The proposed hybrid controller successfully controls the system. The system is able to track and follow the trajectory given in the presence of disturbance or load. Well tuned PID controller has 6 degrees steady state error in the appearance of load. However, the PID-ILC able to return the trajectory reference after the 4th repetition. PID-ILC is able to recover the steady state error of a low gain PID controller after 7 repetition. The capability of tracking the trajectory reference will guarantee the system to follow any set of particular patient rehabilitation scenario

#### REFERENCES

- [1] Fu Y., Wang P., Wang S., Liu H., and Zhang F., "Design and development of a portable exoskeleton based CPM machine for rehabilitation of hand injuries," *2007 IEEE International Conference on Robotics and Biomimetics (ROBIO)*, pp. 1476-1481, 2007.
- [2] Fu Y., Zhang F., Ma X., Meng Q., "Development of a CPM machine for injured fingers," *Proceedings of the 2005 IEEE Engineering in Medicine and Biologi*, vol. 5, pp. 5017-5020, 2005.
- [3] Tangjitsitharoen S., and Lohasiriwat H., "Redesign of a continuous passive motion machine for total knee replacement therapy," *Journal of Health Research*, vol. 33, no. 2, pp. 106-118, 2019.
- [4] Hiemstra L. A., Webber S., and MacDonald P. B., "Knee strength deficits after hamstring tendon and patellar tendon anterior cruciate ligament reconstruction," *Medicine and Science in Sports Medicine*, vol. 32, no. 8, pp.1472-1479, 2000.
- [5] Mikkelsen C., Werner S., & Eriksson E., "Close kinetic chain alone compared to combined open and closed kinetic chain exercises for quadriceps strengthening after anterior cruciate ligament reconstruction with respect to return to sports: A prospective matched follow-up study," *Knee Surgery Sports Traumatology Arthroscopy*, vol. 8, no. 6, pp. 337-342, 2000.
- [6] Delay B. S., Smolinski R. J., Wind W. M., & Bowman D. S., "Current practices and opinions in ACL reconstruction and rehabilitation," *American Journal of Knee Surgery*, vol. 14, no. 2, pp. 85-91, 2001.
- [7] Woo S. L. Y., Wu C., Dede O., Vercillo F., and Noorani S., "Biomechanics and anterior cruciate ligament reconstruction," *Journal of Orthopaedic Surgery and Research*, vol. 1, no. 2, September 2006.
- [8] Lee D. Y. H., Karim S. A., Chang H. C., "Return to sports after anterior cruciate ligament reconstruction – a review of patients with minimum 5-year follow-up," *Annals of the Academy of Medicine, Singapore*, vol. 37, no. 4, pp. 273-278, 2008.
- [9] Rashid M. R., Ahmad I. N., Haron R., and Adnan R., "Treatment effectiveness of continuous passive motion machine during post-operative treatment of anterior cruciate ligament patients," *2012 IEEE Symposium on Humanities, Science and Engineering Research*, pp. 469-473, 2012.
- [10] McInnes J., Larson M. G., Daltroy L. H., et al., "A controlled evaluation of continuous passive motion in patients undergoing total knee arthroplasty," *JAMA*, vol. 268, no. 11, pp. 1423-1428, September 1992.
- [11] Pope R. O., Corcoran S., McCaul K., Howie D. W., "Continuous passive motion after primary total knee arthroplasty: does it offer any benefits?" *The Bone & Joint Journal*, vol. 79, no. 6, pp. 914-917, 1997.

- [12] Shih K. Z., Liu T. K., "The role of continuous passive motion following total knee arthroplasty," *Journal of the Formosan Medical Association*, vol. 89, no. 12, pp. 1077–1080, 1990.
- [13] Ververeli P. A., Sutton D. C., Hearn S. L., et al., "Continuous passive motion after total knee arthroplasty: analysis of cost and benefits," *Clinical Orthopaedics and Related Research*, no. 321, pp. 208–215, 1995.
- [14] Wasilewski S. A., Woods L. C., Torgerson W. R. J., Healy W. L., "Value of continuous passive motion in total knee arthroplasty," *Orthopedics*, vol. 13, no. 3, pp. 291–295, 1990.
- [15] Harms M., Engstrom B., "Continuous passive motion as an adjunct to treatment in the physiotherapy management of total knee arthroplasty patient," *Physiotherapy*, vol. 77, no. 4, pp. 301–307, 1991.
- [16] Johnson D. P., Eastwood D. M., "Beneficial effects of continuous passive motion after total condylar knee arthroplasty," *Annals of the Royal College of Surgeons of England*, vol. 74, no. 6, pp. 412–416, 1992.
- [17] Romness D. W., Rand J. A., "The role of continuous passive motion following total knee arthroplasty," *Clinical Orthopaedics and Related Research*, no. 226, pp. 34–37, 1988.
- [18] Goletz T. H., Henry J. H., "Continuous passive motion after total knee arthroplasty," *Southern Medical journal*, vol. 79, no. 9, pp. 1116–1120, 1986.
- [19] Vince K. G., Kelly M. A., Beck J., Insall J. N., "Continuous passive motion after total knee arthroplasty," *The Journal of Arthroplasty*, vol. 2, no.4, pp. 281–284, 1987.
- [20] Uetsuji S., Kingsuvangul N., Boonyasurakul B., and Charoensuk W., "Hand exoskeleton for continuous passive motion postoperative rehabilitation," *2017 10<sup>th</sup> Biomedical Engineering International Conference (BMEiCON)*, pp. 1-5, 2017.
- [21] Eski I., Kirnap A., and Kirnap M., "PID controller design for human elbow therapy," *International Journal of Applied Mathematics, Electronics and Computers*, no. 4, pp. 282–285, 2016.
- [22] Ortega A. B., Becerra F. A. G., Valdés L. G. V., dan Arcega R. O. D., "A generalized proportional integral controller for an ankle rehabilitation machine based on an XY table," *2013 International Conference on Mechatronics, Electronics and Automotive Engineering*, Morelos, pp. 152-157, 2013.
- [23] Tu Diep Cong Thand., "Control Novel Model of Knee CPM Device, science & technology development," *Science and Technology Development*, vol 12, no. 4, pp 18-29, 2009.
- [24] S. Arimoto, S. Kawamura, and F. Miyazaki, "Bettering operation of robots by learning," *Journal of Robotic Systems*, vol. 1, no. 2, pp.123-140, 1984.
- [25] Ibid, "Bettering operation of dynamic systems by learning: A new control theory for servomechanism or mechatronics systems," *The 23<sup>rd</sup> IEEE Conference on Decision and Control*, pp. 1064-1069, 1984.
- [26] S. Kawamura, F. hliyazaki and S. Arimoto, "Iterative learning control for robotic systems," *2009 IEEE International Conference on Control and Automation, Christchurch*, pp. 1092-1097, 2009.
- [27] Ziegler Z. G., and Nichols N. B., "Optimum settings for automatic controllers," *Trans. ASME*, vol. 64, pp. 759–768, 1942.
- [28] Ang K. H., Chong G., and Li Y., "PID Control System Analysis, Design, and Technology," *IEEE Transactions on Control Systems Technology*, vol. 13, no. 4, pp. 559-576, 2005.
- [29] Skogestad S., "Simple analytic rules for model reduction and PID controller tuning," *Journal of Process Control* vol. 13, no. 4, pp. 291–309, 2003.
- [30] Sutiyasadi P., and Parnichkun M., "Trotting control of a quadruped robot using PID-ILC," in *IECON 2015 - 41<sup>st</sup> Annual Conference of the IEEE Industrial Electronics Society*, pp. 004400-004405, 2015.