

Hybrid fuzzy-PID like optimal control to reduce energy consumption

Hari Maghfiroh¹, Chico Hermanu², Muhammad Hamka Ibrahim³, Miftahul Anwar⁴, Agus Ramelan⁵

^{1,2,3,4,5}Department of Electrical Engineering, Sebelas Maret University, Indonesia

²National Centre of Sustainable Transportation Technology, Indonesia

Article Info

Article history:

Received Nov 16, 2019

Revised Mar 28, 2020

Accepted Apr 12, 2020

Keywords:

DC motor

Energy

Fuzzy

LQR

PID

ABSTRACT

The electric motor is one of the appliances that consume considerable energy. Therefore, the control method which can reduce energy consumption with better performance is needed. The purpose of this research is to minimize the energy consumption of the DC motor with maintaining the performance using Hybrid Fuzzy-PID. The input of the Fuzzy system is the error and power of the system. Where error is correlated with matrix Q and power is correlated with matrix R. Therefore, adjusting the fuzzy rule on error and power is like adjust matrices Q and R in LQR method. The proposed algorithm can reduce energy consumption. However, system response is slightly decrease shown from ISE (Integral Square Error). The energy reduction average is up to 5.58% while the average of ISE increment is up to 1.89%. The more speed variation in the system, the more energy can be saved by the proposed algorithm. While in terms of settling time, the proposed algorithm has the longest time due to higher computation time in the fuzzy system. This performance can be increased by tuning fuzzy rules. This algorithm offers a solution for a complex system which difficult to be modeled.

This is an open access article under the [CC BY-SA](https://creativecommons.org/licenses/by-sa/4.0/) license.



Corresponding Author:

Hari Maghfiroh,

Department of Electrical Engineering,

Sebelas Maret University, Indonesia.

Email: hari.maghfiroh@gmail.com

1. INTRODUCTION

Technological progress and the development of small-scale and large-scale industries use electrical machines in order to support the production process. One technology to support production speed is electric motors with high performance, efficiency, speed dynamics, and good load response. By the type of supply current, there are two kinds of an electric motor which are AC and DC motor. DC motor has some advantages such as easy to control the speed or position and wide adjustable range [1-2]. However, it also has some drawbacks, one of them is, it uses mechanical commutator (brush) which cause high maintenance cost. DC motors are widely used as in steel rolling mills, electric trains, electric vehicles, and robotics actuators [3].

PID is reported that used by 90% industrial section because of its simplicity, applicability, and reliability [4, 5]. However, PID has two major shortcomings, namely the determination of the parameters of PID and its performance decreases as system conditions change [6]. The speed control of the DC motor has been done by a lot of researchers based on performance viewpoints such as in [6, 7]. Since energy is an important issue today, and according to [8], the electric motor is one of the appliances that consume considerable energy, the control method which can reduce energy consumption with better performance is needed.

Linear quadratic regulator (LQR) is one of optimal control method which can be used to reduce the energy consumption by adjusting a cost function. It proved in [9] when compared to PID and fuzzy, LQR gives superior performance with minimum control effort. However, this method needs a system model and some sensors base on the number of the state. The improvement to this method is linear quadratic gaussian (LQG) which can eliminate some or all sensors in LQR and replace them by the estimation method such as Kalman Filter. However, this method needs a complicated calculation.

Fuzzy logic controller (FLC) is one of the artificial intelligence (AI) which using a rule base that convert linguistic rules into control action [10, 11]. Unlike the PID, the principal work of fuzzy is like how humans learn, and it will compare all inputs with certain limitations to produce an output. The main advantage of this method is, it does not require precise mathematical models of the plant [12, 13]. Furthermore, FLC can control complex and non-linear system [14]. It also has the ability to operate in broad range of operation [15, 16]. The comparative study in [9], shown that FLC performance was inferior compare to PID. However, it has lower energy consumption. Therefore, combining the advantages of PID and FLC is an alternative solution to get good performance with minimum energy consumption.

There are a lot of researchers using hybrid fuzzy-PID in DC motor control such as in [17]. However, it only considers the performance without the energy consumed by the system. Therefore, this research proposes a hybrid fuzzy-PID controller for minimizing energy consumption by maintaining good performances. PID is the main control while fuzzy used to supervise the energy consumption and makes PID's parameters adaptive by online tuning base on error and power input. This algorithm is applied in DC motor speed control.

2. RESEARCH METHOD

2.1. System design

The plant used to test the proposed algorithm is a mini conveyor using DC-drive as shown in Figure 1. Arduino Uno used as a microcontroller and 12V 5.5A DC-motor used as DC-drive. The system model is constructed by collecting input-output data of the system using a data logger. The input data is voltage while the output data is the speed of the motor. Using this data, the state-space model of the system is derived using MATLAB system identification. The state-space model of the system is shown in (1).

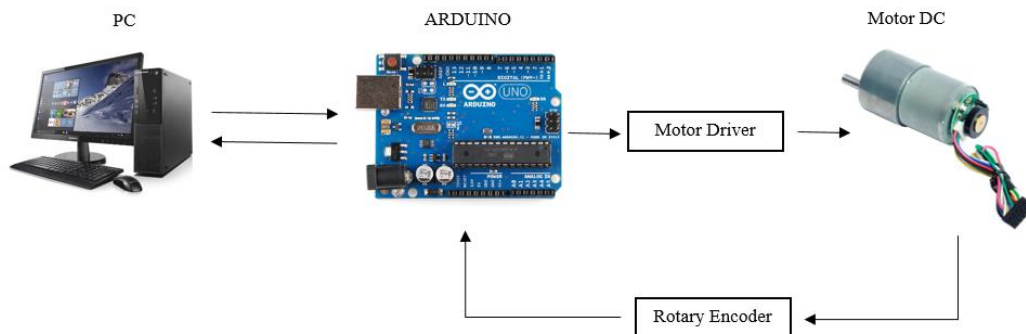

Figure 1. Mini conveyor system

$$\dot{x}(t) = \begin{bmatrix} 0.9 & 0.04 \\ 1 & 0 \end{bmatrix} x(t) + \begin{bmatrix} 1 \\ 0 \end{bmatrix} u(t); y(t) = [1 \quad 0]x(t) \quad (1)$$

2.2. Fuzzy-PID controller

The fuzzy-PID controller is the controller that combines the PID and fuzzy algorithms. In most literature [2, 18, 19], the fuzzy-PID controller is means using fuzzy to tune PID parameters online that makes PID more adaptable. Bansal and Narvey proposed the fuzzy-PID controller for speed control of DC motor [2]. They conclude that fuzzy-PID has a better dynamic response, shorter response time, small overshoot, and small steady-state error (SSE). Conker and Baltacioglu proposed fuzzy self-adaptive PID for driving hydroxy generators with better performance compared to conventional PID method [18]. While Ananthamoorthy and Baskaran proposed hybrid fuzzy-PID controller with a minimum rule base to control permanent magnet synchronous motor [19]. They conclude that this control method can improve speed response and control criteria such as overshoot, steady-state error, and settling time.

All of the references [2, 18, 19] use Fuzzy with two inputs and three outputs where error and change of error as input and three PID parameters as output, shown in Figure 2 (a). This configuration consumes a lot of computation time since the fuzzy system must calculate the three-parameter output. Hari et al. [20] propose PID-hybrid tuning which is using the Ziegler-Nichols method to find the initial value of the PID and fuzzy system to calculate only K_p parameters of PID by implemented PID ideal configuration. This strategy can reduce the computation time of the fuzzy system and successfully implemented in programmable logic controller (PLC). The fuzzy-PID with ideal PID configuration is shown in Figure 2 (b). While N.N. Baharudin and S.M. Ayob proposed single input fuzzy PI controller (SIFPIC) to reduce the rule base of fuzzy-PI controller with the same responses [21]. On the other hand, Qi Chen, et al. [22], proposed a fuzzy P + ID controller for a cable laying system. In this system, PID parallel configuration is used. However, the fuzzy system only tunes K_p while K_i and K_d is remain constant.

Bambang Sumantri et al. [23] have proved that Fuzzy-PID can reduce energy consumption compared to conventional PID controllers which applied in a two-wheel electric skateboard. However, the performance index, rise time, settling time, etc., not clearly explained. Moreover, the fuzzy-PID controller still using parallel PID configuration which uses a lot of fuzzy rules. To reduce the complexity of fuzzy rules, only K_p and K_i which tuned.

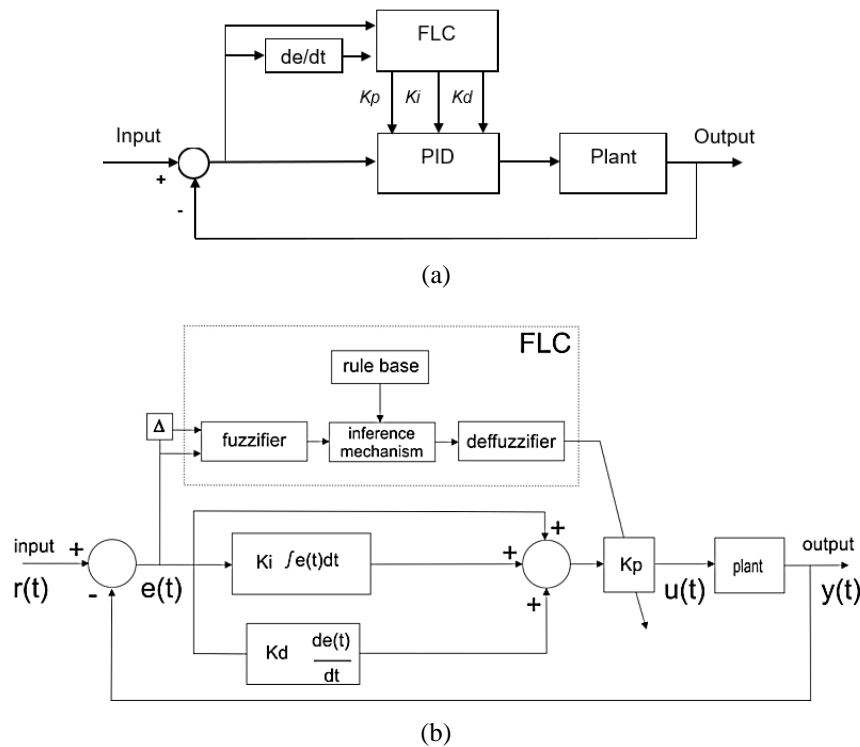

Figure 2. Fuzzy-PID configuration: (a) fuzzy-PID with parallel PID configuration, (b) fuzzy-PID with ideal PID configuration [20]

2.3. Hybrid Fuzzy-PID like optimal control

LQR is one of the optimal control techniques which consider the states of the system and control input to make optimal control decisions. According to [24], this method is simple and robust. Suppose the state equation of the system is:

$$\begin{aligned} \dot{x}(t) &= A.x(t) + B.u(t) \\ y(t) &= C.x(t) + D.u(t) \end{aligned} \tag{2}$$

The state feedback control is $u(t) = -K_{LQR} x(t)$, where K_{LQR} is derived from the minimization of cost function as shown in (3).

$$J = \int (x^T(t)Qx(t) + u^T(t)Ru(t))dt \tag{3}$$

The matrices Q and R determine the relative importance of the error and the expenditure of energy [25]. Therefore, the trade-off between performance and energy used can be set by choosing an appropriate element of matrices Q and R. In hybrid fuzzy-PID like optimal control, FLC is used to supervise the energy used by PID. The input of FLC is the error and power of the system. Where error is correlated with matrix Q and power is correlated with matrix R. Therefore, adjusting the fuzzy rule on error and power is like adjusting Q and R matrices. This method will be very useful for a complex system where its system model is difficult to find.

The structure of the proposed algorithm is shown in Figure 3. To reduce computation time, the ideal PID structure is used. The (4) shows that the variation of K_p in the ideal PID will affect all the controller outputs. Therefore, only K_p which tuned online by the fuzzy system. The value and membership function are shown in Figure 4 (a) while the Fuzzy rule is shown in Figure 4 (b). Where NB (negative big), NS (negative small), ZE (zero), PS (positive small), PB (positive big), VMN (very minimum), MN (minimum), MED (medium), MX (maximum), VMX (very maximum), VSM (very small), SM (small), MDM (medium), B (big), and VB (very big). In this research, the inference mechanism method is using Mamdani. The rule base consists of 25 rules. The center of gravity (COG) is used for the defuzzification method.

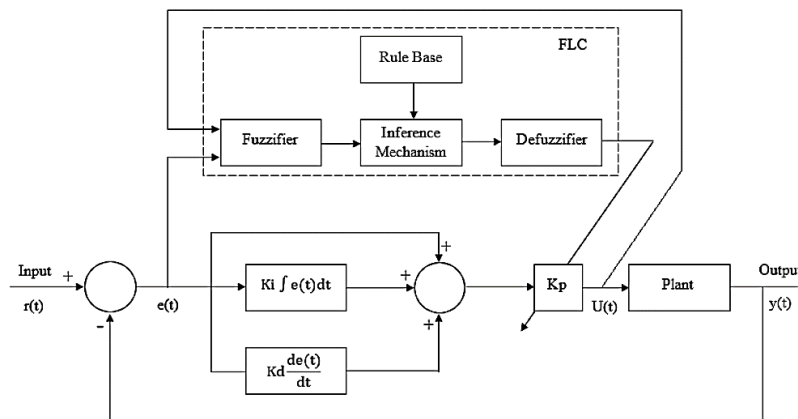
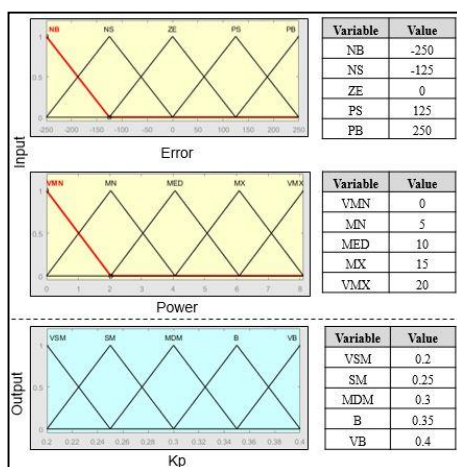

Figure 3. Block diagram of hybrid fuzzy-PID

$$y(t) = K_p [e(t) + K_I * \int e(t)dt + (K_D * \frac{de(t)}{dt})] \tag{4}$$



(a)

E \ Power	NB	NS	ZE	PS	PB
VMN	VSM	VSM	MDM	B	VB
MN	SM	SM	MDM	B	B
MED	VSM	SM	MDM	SM	VB
MX	SM	SM	MDM	SM	SM
VMX	VSM	SM	MDM	SM	VSM

(b)

Figure 4. Fuzzy logic controller components; (a) membership function, (b) rule base

3. RESULTS AND ANALYSIS

Two algorithms are tested and compared with the proposed algorithm which is PID and LQR. Before implemented in real hardware, the algorithm is simulated. Parameter tuning also was done in the simulation step, for example, finding the PID parameter and LQR gain matrix. PID tuning is done by MATLAB auto-tuning, which are $K_p = 0.3$, $K_i = 0.386$, and $K_d = 0.042$. While LQR gain is calculated manually which is $K_{LQR} = [1.97 \ 0.14]$. Fuzzy membership is defined based on PID while its rule base is based on the trial. After founded a good result in the simulation stage, the algorithms are tested in real hardware. The result of the hardware implementation will be discussed in this section. Three condition testing is carried out which are the no-load test, loaded test, and speed variation.

3.1. No-load test

The no-load test is mean the plant which is mini conveyor driven by DC-motor is run without the load on it. The test is done in two set point speed: 100 rpm, which represent low speed, and 200 rpm which represent high speed. Figure 5 is the result of the no-load test which including speed profile, energy profile, and ISE (integral square error) profile. ISE used as a performance parameter. The smallest ISE, the better the performance. Figure 5 (a), shown that LQR has the fastest response to reach the setpoint, while PID and hybrid fuzzy-PID has nearly the same response. Detail settling time is summarized in Table 1. It is shown that LQR nearly four times faster compare with PID and hybrid fuzzy-PID.

Figure 5 (b) and 5 (c) show the cumulative energy and ISE of the three tested algorithms. The energy curve is increased linearly while ISE increases and became a steady state when the system response reaches a steady-state area. In terms of energy, LQR also superior compare to PID and hybrid fuzzy-PID by consuming the lowest amount of energy. While, hybrid fuzzy-PID which has nearly the same speed profile with PID, has lower energy consumption compare to PID. However, it has higher ISE. PID is used as a basis for comparison, where it consumes 100% of energy and 100% of ISE, Table 1. In an energy viewpoint, hybrid fuzzy-PID decreases energy consumption by up to 3.6% with increasing ISE by up to 6.48% compared to PID.

The algorithm tested in higher speed reference which is 200 rpm. Figure 5 (d) shows the speed profile response of the system. LQR still the fastest time to reach the set point. At this test, LQR has settling time two times faster compared with PID. While Hybrid Fuzzy-PID has the slowest settling time which is only 4 seconds or 13,4% behind PID's time. While the total energy used, and ISE are summarized in Table 1. With PID as the base comparison, LQR reduces energy consumption by up to 6% while hybrid fuzzy-PID saves energy by up to 3.24%. From the ISE comparison, LQR lead by lowest ISE which is 31.33% lower than PID. Hybrid Fuzzy-PID is also giving a better performance with lower ISE by up to 1.01% compared with PID.

Table 1. No-load test

Method	Settling Time (second)	Total Energy Used (Joule)	% Energy	Integral Square Error (ISE)	% ISE
Speed 100 rpm					
PID	19	1191.72	100	145384	100
Hybrid Fuzzy-PID	21	1148.87	96.4	154807	106.48
LQR	5	1116.73	93.7	98140	67.5
Speed 200 rpm					
PID	30	2264	100	519026	100
Hybrid Fuzzy-PID	34	2190.57	96.76	513783	98.99
LQR	15	2129	94	356408	68.67

3.2. Loaded test

Since the application of the conveyor is to move the load, the loaded test is also carried out. The test is done at the same set point which is 100 rpm and 200 rpm. The test is carried out using three loads with different weights. The loading is done in stages, the first load, then the second load is added, and finally, the third load is added. The total mass of the first, second, and third load is 2 kg, 2.75 kg, and 3 kg respectively. Figure 6 shows the speed profile, energy profile, and ISE profile of loaded test. The addition of load makes speed oscillation in the system. The heavier the load, the greater the speed oscillation. All the algorithms work well in this test. In the first loading, hybrid fuzzy-PID has the lowest overshoot, while PID and LQR have the same result. Then in the second loading, Hybrid Fuzzy-PID still better with the lowest overshoot. In the last loading, hybrid fuzzy-PID is also superior compare with others, while LQR has a higher overshoot. From the energy point of view, Figure 6 (b), LQR has the lowest energy consumption with 6.21% lower than PID. Hybrid fuzzy-PID reduces the energy consumption by up to 3.32%. While in

the ISE profile, LQR is still the lowest. PID and hybrid fuzzy-PID has nearly the same result with a small difference only 0.19%. The higher contribution in the ISE value is in the starting point when the system starts to reach the first set point before the load added. Detail results are shown in Table 2.

Loaded test also carried out at high speed which is 200 rpm. Figure 6 (d) shows the speed profile of the system. It has seen that; the speed oscillation due to loading is reduced. The higher the speed, the conveyor system became more stable to the loading. LQR is faster to reach the set point before loaded. In the first and second loading, LQR has the highest overshoot, while PID and hybrid fuzzy-PID has the same result. In the last loading, hybrid fuzzy-PID has the lowest overshoot. Maximum overshoot during loading is listed at Table 2. Table 2 shows the data from the energy and ISE point of view. It clearly is seen that LQR is superior both in energy and ISE compare with two others. While hybrid fuzzy-PID reduces the energy consumption by up to 4.44% compare with PID. However, in the ISE, it has higher ISE which is 2.3% higher. This is mostly affected by the longer settling time of the first time to reach the set point.

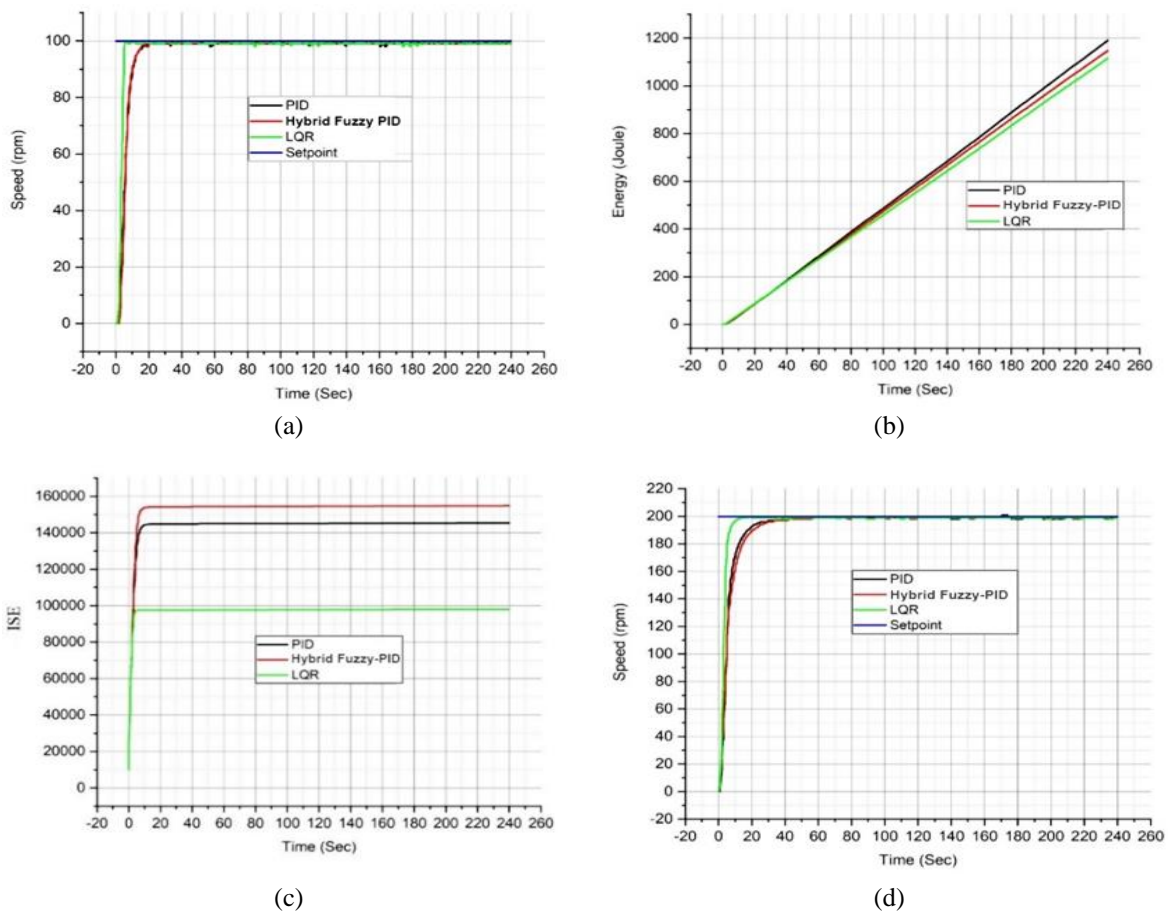

Figure 5. No-load test; (a) speed profile 100 rpm, (b) energy profile 100 rpm, (c) ISE profile 100 rpm, (d) speed profile 200 rpm

Table 2. Loaded test

Method	Max % overshoot	Total Energy Used (Joule)	% Energy	Integral Square Error (ISE)	ISE (%)
Speed 100 rpm					
PID	18	1270.92	100	167232	100
Hybrid Fuzzy-PID	12	1228.77	96.68	166927	99.81
LQR	20	1192	93.79	116774	69.83
Speed 200 rpm					
PID	5	2333.13	100	515008	100
Hybrid Fuzzy-PID	4	2229.57	95.56	527005	102.3
LQR	3.5	2214.46	94.91	388949	75.5

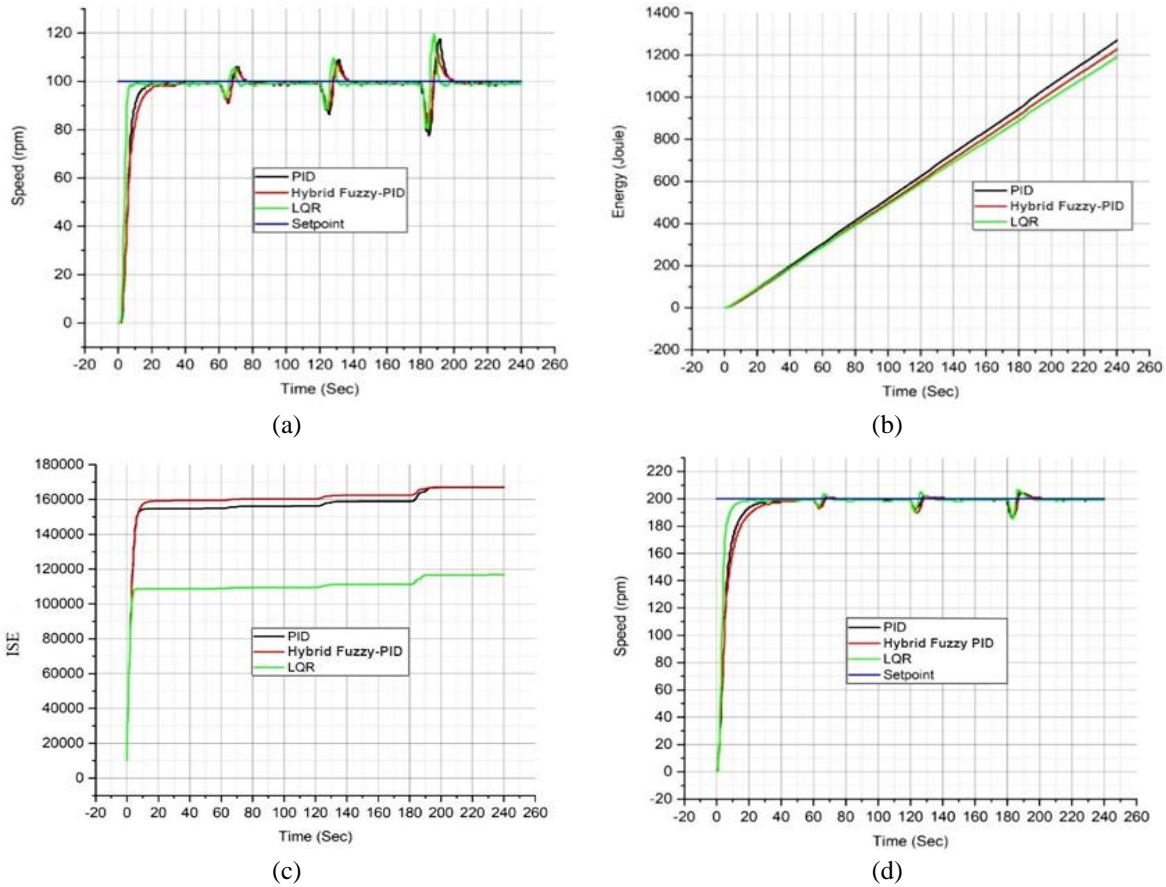

Figure 6. Loaded test; (a) speed profile 100 rpm, (b) energy profile 100 rpm, (c) ISE profile 100 rpm, (d) speed profile 200 rpm

3.3. Speed variation test

The last test scheme is speed variation without loading. In this test, the speed reference is varied from 70 rpm to 120 rpm then to 200 rpm. Figure 7 is showing the system response which is speed profile, energy profile, and ISE profile. Speed profile has shown that LQR has a faster response to follow speed changes. While hybrid fuzzy-PID is the slowest one. However, its response is nearly the same as PID.

In Figure 7 (b), it is seen that LQR has the lowest energy consumption, followed by hybrid fuzzy-PID and PID in the last. Figure 7 (c) shown the ISE, LQR has the lowest value, while hybrid fuzzy-PID has a higher value but near PID's value. The quantitative result of energy and ISE is in Table 3. Although LQR has the best result in energy saving, hybrid fuzzy-PID can increase the energy-saving by up to 13.28% with increasing ISE only 1.87%. In this test, LQR saves energy up to 30.11% with lower ISE by up to 18.35% compare to PID.

Table 3. Speed variation

Method	Total Energy Used (Joule)	% Energy	Integral Square Error (ISE)	ISE (%)
PID	1541.51	100	188056	100
Hybrid Fuzzy-PID	1336.76	86.72	191570	101.87
LQR	1077.46	69.89	153548	81.65

Table 4 resumes the energy and ISE reduction from all tests that have done. The negative sign means reduction, while positive means increment. For all the tests, the proposed algorithm reduces energy consumption. On the other hand, the ISE is increased except for the second and third test which give only a small reduction. The average of all the results is energy reduction by 5.58% and ISE increment by 1.89%.

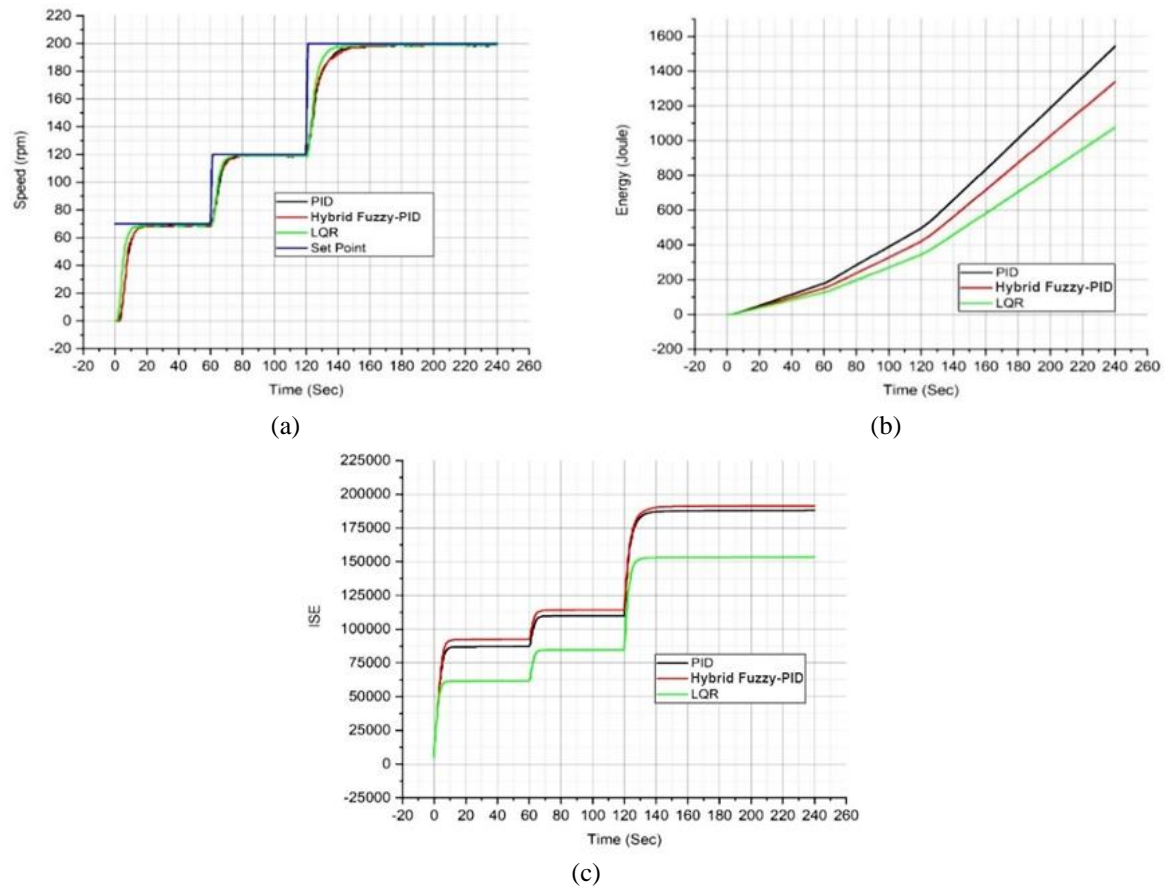

Figure 7. Speed variation; (a) speed profile, (b) energy profile, (c) ISE profile

Table 4. Resume of energy and ISE reduction

Data source		% Energy reduction	% ISE reduction
Table 1	100 rpm	- 3.6	+ 6.48
	200 rpm	- 3.24	- 1.01
Table 2	100 rpm	- 3.32	- 0.19
	200 rpm	- 4.44	+ 2.3
Table 3		- 13.28	+ 1.87
Average		-5.58	+1.89

4. CONCLUSION

The proposed algorithm is simple in mathematical calculation; however, it needs a longer program to be implemented. It was successfully implemented in the real hardware system. The test was carried out with three schemes which are no-load, loaded, and speed variation. The result has shown that LQR is superior both in performance and energy consumption compared with PID and Hybrid Fuzzy-PID. The proposed algorithm can reduce energy consumption. However, system response is slightly decreased as shown from ISE. The energy reduction average is up to 5.58% while the average of ISE increment is up to 1.89%. The more speed variation in the system, the more energy can be saved by the proposed algorithm. Although its performance is lower than the LQR, the proposed algorithm has advantages that is only use one sensor in this case, while LQR using two sensors for every state which is speed sensor and current sensor. While in terms of settling time, the proposed algorithm has the longest time due to higher computation time in fuzzy system. This performance can be increased by tuning fuzzy rules. This algorithm offers a solution for a complex system which difficult to be modeled.

ACKNOWLEDGEMENT

This paper was supported by USAID through SHERA Program-NCSTT.

REFERENCES

- [1] A. Faramarzi and K. Sabahi, "Recurrent Fuzzy Neural Network for DC- motor control," *2011 Fifth International Conference on Genetic and Evolutionary Computing*, pp. 93–96, 2011.
- [2] U. K. Bansal and R. Narvey, "Speed Control of DC Motor Using Fuzzy PID Controller," *Advance in Electronic and Electric Engineering*, vol. 3, no. 9, pp. 1209–1220, 2013.
- [3] A. Hughes and B. Drury, "Electric Motor and Drives: Fundamental, Types and Applications," 5th ed. *Elsevier*, 2019.
- [4] K. H. Ang, G. Chong, S. Member, and Y. Li, "PID Control System Analysis , Design , and Technology," *IEEE Transactions on Control Systems Technology*, vol. 13, no. 4, pp. 559–576, 2005.
- [5] S. M. Rakhtala and E. S. Roudbari, "Application of PEM Fuel Cell for Stand-alone Based on a Fuzzy PID Control," *Bulletin of Electrical Engineering and Informatics*, vol. 5, no. 1, pp. 45–61, 2016.
- [6] A. Balestrino, A. Caiti, V. Calabró, E. Crisostomi, and A. Landi, "From Basic to Advanced PI Controllers : A Complexity vs . Performance Comparison," *Advance in PID Control, Intech*, pp. 87–100, 2011.
- [7] P. H. B. Kazemian, "Intelligent Fuzzy PID Controller," *Foundation of Generic Optimization, Springer*, vol. 2 pp. 241–260, 2008.
- [8] J. De Oliveira, A. Nied, M. H. F. Santos, and R. P. Dias, "Study on the Energy Efficiency of Soft Starting of an Induction Motor with Torque Control," *Advases in Motor Torque Control, Intech*, pp. 33–46, 2011.
- [9] H. Maghfiroh, A. Ataka, O. Wahyunggoro, and A. I. Cahyadi, "Optimal Energy Control of DC Motor Speed Control : Comparative Study Optimal Energy Control of DC Motor Speed Control : Comparative Study," *2013 International Conference on Computer, Control, Informatics and Its Applications*, 2013.
- [10] F. Cupertino, A. Lattanzi, L. Salvatore, "A New Fuzzy Logic-Based Controller Design Method for DC and AC Impressed-Voltage Drives," *IEEE Transactions on Power Electronics*, vol. 15, no. 6, pp. 974–982, 2000.
- [11] D. Ramot, M. Friedman, G. Langholz, and A. Kandel, "Complex Fuzzy Logic," *IEEE Transactions on Fuzzy Systems*, vol. 11, no. 4, pp. 450–461, 2003.
- [12] M. M. Shaker and Y. Khasab, "Design and Implementation of Fuzzy Logic system for DC motor Speed Control," *Iraq J. Electrical and Electronic Engineering*, vol. 6, no. 2, pp. 123–130, 2010.
- [13] M. Cheng, Q. Sun, E. Zhou, "New Self-Tuning Fuzzy PI Control of a Novel Doubly Salient Permanent-Magnet Motor Drive," *IEEE Transactions on Industrial Electronics*, vol. 53, no. 3, pp. 814–821, 2006.
- [14] S. Jamian et al., "Review on controller design in pneumatic actuator drive system," *TELKOMNIKA Telecommunication Computing Electronics and Control*, vol. 18, no. 1, pp. 332–342, 2020.
- [15] C. Volosencu, "Control of Electrical Drives Based on Fuzzy Logic," *WSEAS Transactions on Systems and Control*, vol. 3, no. 9, pp. 809–822, 2008.
- [16] A. Ghareaghaji, "A Comparison between Fuzzy-PSO Controller and PID- PSO Controller for Controlling a DC Motor," *Bulletin of Electrical Engineering and Informatics*, vol. 4, no. 2, pp. 130–135, 2015.
- [17] D. Somwanshi, M. Bunde, G. Kumar, and G. Parashar, "Comparison of Fuzzy-PID and PID Controller for Speed Control of Comparison of Fuzzy-PID and PID Controller for Speed Control of DC Motor using LabVIEW DC Motor using LabVIEW," *Procedia Computer Science*, vol. 152, pp. 252–260, 2019.
- [18] C. Conker and M. K. Baltacioglu, "Fuzzy self-adaptive PID control technique for driving HHO dry cell systems," *International Journal of Hydrogen Energy*, pp. 1–11, 2020.
- [19] N. Ananthamoorthy and K. Baskaran, "High performance hybrid fuzzy PID controller for permanent magnet synchronous motor drive with minimum rule base," *Journal of Vibration and Control*, pp. 1–14, 2013.
- [20] H. Maghfiroh, O. Wahyunggoro, A. I. Cahyadi, and S. Praptodiyono, "PID-Hybrid Tuning to Improve Control Performance in Speed Control of DC Motor Base on PLC," *3rd International Conference on Instrumentation Control and Automation (ICA) 2013*, pp. 233–238.
- [21] N. N. Baharudin and S. M. Ayob, "Brushless DC Motor Speed Control Using Single Input Fuzzy PI Controller," *International Journal of Power Electronics and Drive Systems*, vol. 9, no. 4, pp. 1952–1966, 2018.
- [22] Q. Chen, W. Li, and G. Chen, "A FUZZY P + ID Controller for a Constant Tension Winch in a Cable Laying System," *IEEE Transactions on Industrial Electronics*, vol. 64, no. 4, 2016.
- [23] B. Sumantri, E. H. Binugroho, I. M. Putra, and R. Rokhana, "Fuzzy-PID controller for an energy efficient personal vehicle : Two-wheel electric skateboard," *International Journal of Electrical and Computer Engineering*, vol. 9, no. 6, pp. 5304–5311, 2019.
- [24] L. B. Prasad, B. Tyagi, and H. O. Gupta, "Optimal Control of Nonlinear Inverted Pendulum Dynamical System with Disturbance Input using PID Controller and LQR," *2011 IEEE Int.Con. on Control System, Computing and Engineering*, pp. 540–545, 2011.
- [25] K. Ogata, "Modern Control Engineering," 5th ed. New Jersey: *Prentice Hall*, 2010.