

# Novel Design of a Magnetically Switchable MOSFET using Magnetoresistive Elements

Chinmay Vilas Samak, Tanmay Vilas Samak

B.Tech. First Year Student, Mechatronics Department, SRM Institute of Science & Technology,  
Kattankulathur 603203 Kancheepuram Dt., Tamil Nadu, Ph: 044-27417777,  
Fax: 044-27453903, India

\*Corresponding author, e-mail: samakchinmayvilas@gmail.com<sup>1</sup>, samaktanmay@gmail.com<sup>2</sup>

## Abstract

Various research activities have been carried out, individually, in the fields of MOSFET design and analysis, and magnetoresistance; however, our research focused on the design and analysis of a magnetically switchable MOSFET with the application of magnetoresistive elements. Theoretical study, calculations and simulations were used in order to design and analyze the magnetically switchable MOSFET. It was observed that the magnetoresistance values of 42%, 81% and 95%, respectively, for giant magnetoresistive element, tunneling magnetoresistive element and colossal magnetoresistive element resulted in reduced resistance values of 139.2Ω, 45.6Ω and 12Ω across the MOSFET in presence of magnetic field; as compared to a higher value of 240Ω in its absence. As a consequence, the gate-source voltage increased beyond the threshold value (1.5V), and the MOSFET switched ON. Accordingly, a magnetically switchable MOSFET was designed and its behavioural characteristics were analyzed.

**Keywords:** magnetoresistance, MOSFET, threshold voltage

Copyright © 2018 Universitas Ahmad Dahlan. All rights reserved.

## 1. Introduction

Magnetoresistance (MR) is the property of a material to change its electrical resistance in accordance with an external magnetic field. Ordinary Magnetoresistance (OMR) [1] is exhibited by bulk materials (non-magnetic metals and semiconductor materials), since the conduction electrons are forced to move in helical trajectories due to Lorentz Force exerted by the applied magnetic field; but its value is very small (~5%) and is therefore not suitable for any practical applications.

Another class of magnetoresistance called Anisotropic Magnetoresistance (AMR) [2], discovered by W. Thomson [3] in 1856, is exhibited by ferromagnetic metals and alloys, and is dependent upon the relative direction of electric current and applied magnetic field; however, its value also is small (2% to 5%). Nonetheless, research and technological advancements have made it possible to synthesize multicomponent or multilayer materials with higher magnetoresistance. These include Giant Magnetoresistance (GMR) [4, 5], Tunneling Magnetoresistance (TMR) [6] and Colossal Magnetoresistance (CMR) [7, 8]. Magnetoresistance can be expressed as [9],

$$MR\% = \frac{R_o - R_H}{R_o} \quad (1)$$

where,  $MR\%$  is the magnetoresistance in %,  $R_H$  is the resistance offered by the MR element in saturation magnetic field ( $H = H_s$ ) and  $R_o$  is the resistance offered by the same MR element at  $H = 0$ .

MOSFETs [10] are unipolar devices with high input impedance, low output impedance and their switching can be controlled by the applied electric field. The best property of MOSFETs (unlike that of JFETs) is that these can be operated not only in depletion mode (normally ON state), but also in enhancement mode (normally OFF state) and hence find applications in switching digital systems.

Our research addresses the problem of designing and analysing a magnetically switchable MOSFET which will prove to be useful in the development of magneto-electronic

devices and sensors in the future, controlling electromagnetic actuators in robotic and mechatronic systems, etc.

This research, therefore proposes to control the electric field applied across n-channel e-MOSFETs using the magnetoresistance phenomenon (the same concept can be extrapolated to p-channel e-MOSFETs as well); and proposes the use of GMR, TMR and CMR elements for the purpose of designing a magnetically switchable MOSFET.

Various research activities and advancements have been made, individually, in the fields of MOSFET design, its analysis and applications, and magnetoresistance; however, our research focuses on the fusion of both, MOSFET design and magnetoresistance, in order to design a magnetically switchable MOSFET and analyse its behaviour.

## 2. Proposed Method

As shown in Figure 1, the input gate voltage  $V_{GS}$  is responsible for the generation of electric charges on the metal (Al) contact at the gate. This further induces equal and opposite charges on the substrate side due to the MOS capacitor system. Up to a certain threshold gate voltage,  $V_{TH}$  [11] (determined from the transfer characteristics of the MOSFET), the induced charges counter the oppositely charged dopant ions present in the substrate, thereby forming a depletion layer. Further increasing the gate voltage leads to the formation of an inversion layer in the substrate region and thus, a drain current  $I_D$  flows through the induced channel from drain to source.

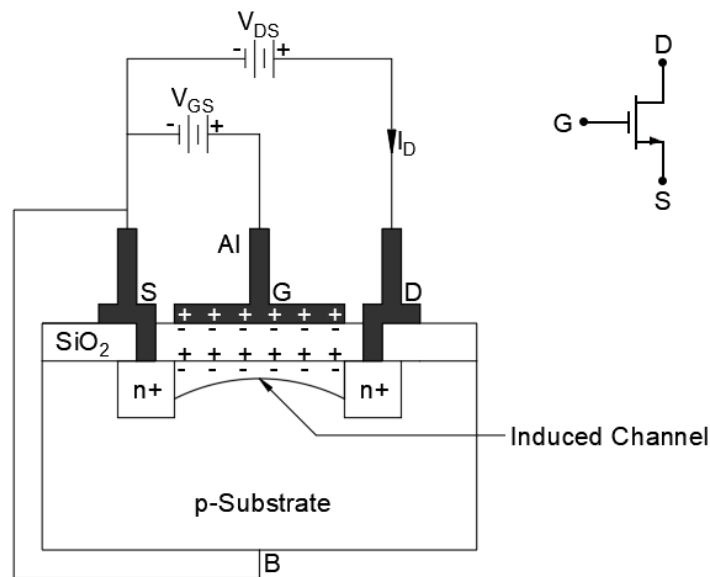

Figure 1. n-Channel e-MOSFET Structure

Consider two resistors  $R_{in}$  and  $R_{GS}$  connected at the gate terminal of the MOSFET as shown in the Figure 2. The potential drop across  $R_{in}$  is responsible for a reduced voltage across  $R_{GS}$ , which is also the effective gate-source voltage  $V_{GS}$ . According to voltage division rule,

$$V_{GS} = V_{in} \left( \frac{R_{GS}}{R_{in} + R_{GS}} \right) \quad (2)$$

If appropriate values of  $R_{in}$  and  $R_{GS}$  are chosen such that  $V_{GS} < V_{TH}$ , the MOSFET will act as an open switch (OFF state); else, if  $V_{GS} \geq V_{TH}$ , the MOSFET will act as a closed switch (ON state). The switching of an n-channel e-MOSFET has been summarized in Table 1.

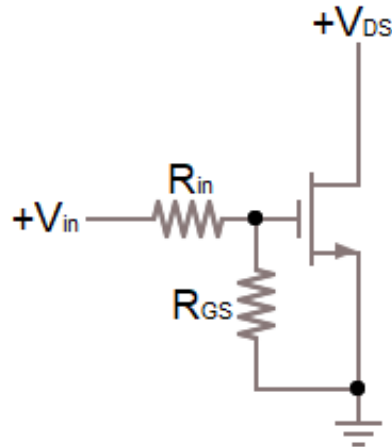

Figure 2. Switching Circuit

Table 1. n-Channel e-MOSFET Switching Table

$V_{GS} \geq V_{TH}$	$V_{GS} < V_{TH}$
ON	OFF

Now if we fix the value of  $R_{GS}$  and replace the resistor  $R_{in}$  with a magnetoresistive element, we will be able to vary  $V_{GS}$  using an external magnetic field; and thus, be able to control switching of the MOSFET. Accordingly, a magnetically switchable MOSFET shall be formed.

### 3. Research Method

For the purpose of designing and simulating a magnetically switchable MOSFET, the input voltage  $V_{in}$  was fixed at 5.0V and  $R_{GS}$  was fixed at 100 $\Omega$ . The threshold voltage,  $V_{TH}$  was taken to be 1.5V. The value of  $R_o$  was calculated using equation 2 (by replacing  $R_{in}$  with  $R_o$ ), such that the MOSFET remained in OFF state.

$$V_{TH} > V_{in} \left( \frac{R_{GS}}{R_o + R_{GS}} \right)$$

$$1.5V > 5V \left( \frac{100\Omega}{R_o + 100\Omega} \right)$$

$$R_o > 233.33\Omega$$

The nearest standard value of  $R_o$ , i.e. 240  $\Omega$ , was considered for calculations. The values of magnetoresistance for GMR, TMR and CMR elements were used to study the switching characteristics of the MOSFET. For this purpose, MR values at room temperature (300 K) were taken as follows: GMR=42% [12], TMR=81% [13] and CMR=95% [14]. The resistance offered by different MR elements in a saturation magnetic field  $H_s$  was calculated using equation 1, as follows:

$$R_{HGMR} = 240 - (42\% * 240) = 139.2\Omega$$

$$R_{HTMR} = 240 - (81\% * 240) = 45.60\Omega$$

$$R_{HCMR} = 240 - (95\% * 240) = 12.00\Omega$$

The magnitudes of  $V_{GS}$  corresponding to GMR, TMR and CMR were calculated, and used to study the behavioural characteristics of the magnetically switchable MOSFET. After confirming the simulation results, a simple design of magnetically switchable MOSFET, which can be manufactured using existing technology without much alterations in production techniques, was proposed.

#### 4. Results and Discussion

The simulation results confirmed the expected behaviour of the magnetically switchable MOSFET. It was seen that as the magnetoresistance value increased, so did the gate-source voltage  $V_{GS}$  and consequently, the drain current  $I_D$  also went on increasing thereby switching the MOSFET from OFF state to ON state in presence of magnetic field. This can be inferred from the drain characteristics of the magnetically switchable MOSFET as shown in Figure 3.

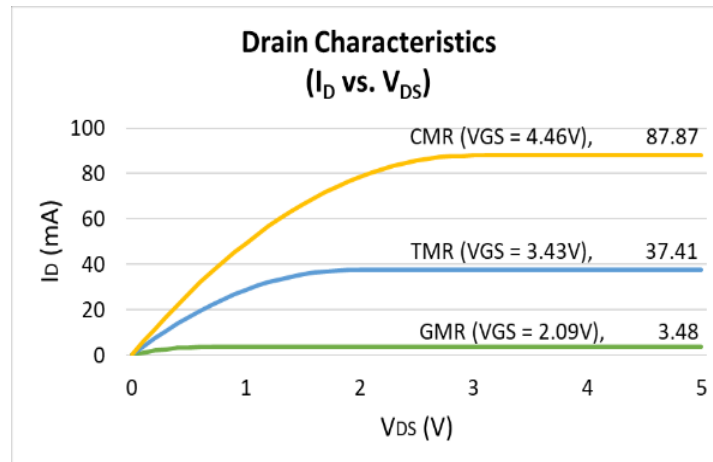

Figure 3. Drain characteristics of MOSFET with GMR, TMR and CMR elements

When analyzed the variation of the gate-source voltage  $V_{GS}$  with respect to the magnetoresistance value as shown in Figure 4, it not only indicated that  $V_{GS}$  increased for a higher MR value but also pinpointed a more important aspect of the magnetically switchable MOSFET.

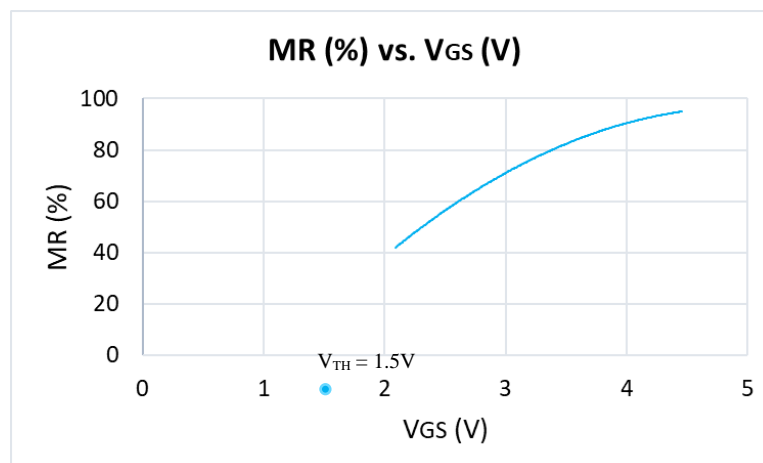

Figure 4. Dependence of MOSFET switching on magnetoresistance value and threshold voltage of the MOSFET

Since the threshold voltage of the MOSFET used for simulation was 1.5V, it switched ON successfully in case of all the three MR elements. However, if the threshold value was to be considerably above 2.09V ( $V_{GS}$  of MOSFET with GMR element), the MOSFET would not switch ON in case of GMR element; and if it was to be considerably above 3.43V ( $V_{GS}$  of MOSFET with TMR element), the MOSFET would switch ON only in case of CMR element (refer to Table 2).

Table 2. Dependence of MOSFET Switching on MR Value and Threshold Voltage

Threshold Voltage ( $V_{TH}$ )	MOSFET Switching State		
	GMR	TMR	CMR
$V_{TH} < 2.09V$	ON	ON	ON
$3.43V > V_{TH} > 2.09V$	OFF	ON	ON
$4.46V > V_{TH} > 3.43V$	OFF	OFF	ON
$V_{TH} > 4.46V$	OFF	OFF	OFF

Simulation also indicated that the input resistance  $R_{in}$  is inversely proportional to the magnetoresistance value of the MR element as shown in Figure 5, which is in accordance with equation 1. As shown in Figure 6, the drain current  $I_D$  showed a significant increase in its magnitude from GMR element (least MR value) to CMR element (highest MR value). This can also be inferred from the drain characteristics of the MOSFET as shown in Figure 3.

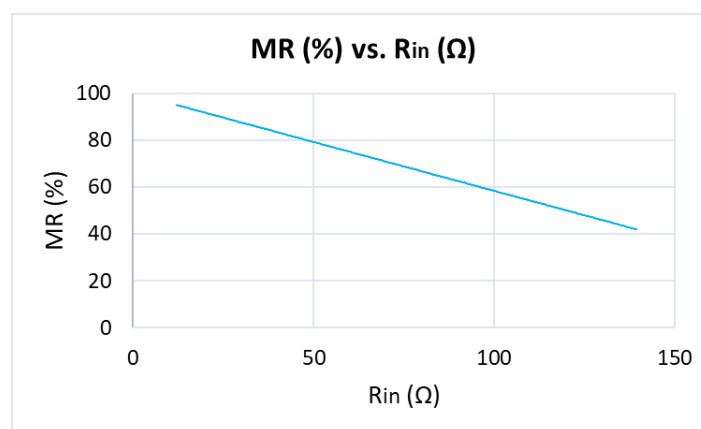
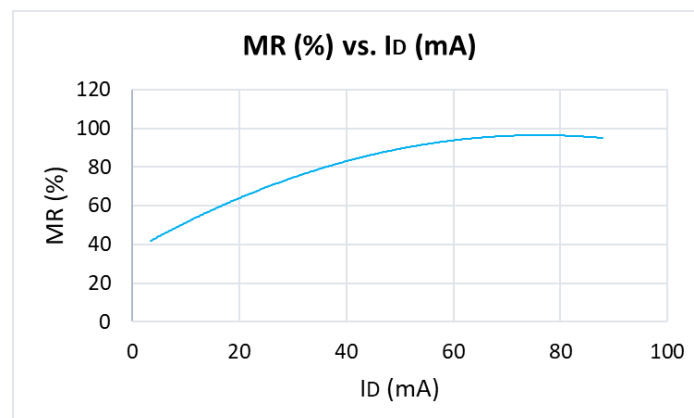
Figure 5. Comparison between magnitude of input resistance  $R_{in}$  and the magnetoresistanceFigure 6. Variation of  $I_D$  with respect to the magnetoresistance ratio

The design of a magnetically switchable n-channel e-MOSFET was proposed by internally connecting a magnetoresistive element 'MR' at the gate and a variable resistor 'VR' across the gate and source of the MOSFET package as shown in Figure 7. Note that the variation terminal (screw, or similar) of the variable resistor is to be brought outside the package for its convenient variation. Also note that a fixed resistor may be used but, will require the input parameters of the MOSFET (like  $V_{GS}$ ,  $V_{TH}$ , etc.) to be restricted.

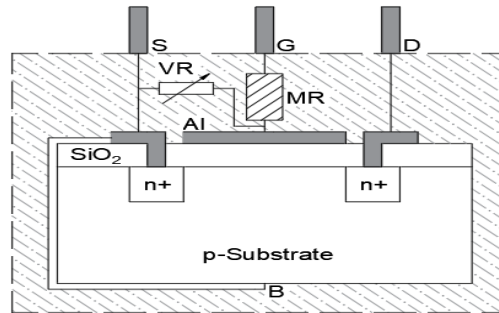

Figure 7. Proposed Design of a Magnetically Switchable n-channel e-MOSFET

## 5. Conclusion

Thus, a magnetically switchable MOSFET was designed with the application of magnetoresistive elements. Analysis showed that in absence of an external magnetic field ( $0 \leq H < H_s$ ), the resistance of MR elements was high ( $240\Omega$ ). However, in the presence of external magnetic field ( $H \geq H_s$ ), the resistance was reduced to  $139.2\Omega$ ,  $45.6\Omega$  and  $12.0\Omega$ , respectively for GMR, TMR and CMR elements. This resulted in greater value of  $V_{GS}$  (such that  $V_{GS} > V_{TH}$ ), which switched ON the MOSFET. The magnetic switching of MOSFET is summarized in Table 3. It was also concluded that the switching of such a MOSFET will not only depend upon its threshold voltage, but also on the magnetoresistance of the MR element.

Table 3. Magnetic Switching of MOSFET

Magnetic Field ( $H$ )	$V_{GS}$	Switching State
$0 \leq H < H_s$	$V_{GS} < V_{TH}$	OFF
$H \geq H_s$	$V_{GS} \geq V_{TH}$	ON

## References

- [1] Thiruvadigal JD, Ponnusamy S, Sudha D, Krishnamohan M. Materials Science. Chennai: SSS Publication. 2015: 2.19-2.22.
- [2] Mc Guire T, Potter R. Anisotropic Magnetoresistance in Ferromagnetic 3d Alloys. *IEEE Transactions on Magnetics*. 1975; 11(4): 1018-1038.
- [3] Thomson W. *On the Electro-Dynamic Qualities of Metals: Effects of Magnetization on the Electric Conductivity of Nickel and of Iron*. Proceedings of the Royal Society of London. 1857; 8: 546-550. Class for Physics. The Discovery of Giant Magnetoresistance. The Royal Swedish Academy of Sciences. 2007.
- [4] Chang L et al. A brief introduction to giant magnetoresistance. Hycorelle Co., Ltd., Beijing, China. 2014.
- [5] Mathon, J. Theory of Tunneling Magnetoresistance. *Phase Transitions*. 2003; 76(4-5): 491-500.
- [6] Ramirez AP. Colossal magnetoresistance. *Journal of Physics: Condensed Matter*. 1997; 9(39): 8171.
- [7] Shirato N. Colossal Magnetoresistance. Department of Materials Science and Engineering, University of Tennessee, Knoxville. 2010.
- [8] Gljs MAM, Giesbers JB. Magneto-Resistancedevice and Magnetic Head Comprising Such a Device. US005527626A (Patent). 1996.
- [9] Tandjaoui MN, Benachaiba C, Abdelkhalek O, Denai B, Mouloudi Y. Characterization and Modeling of Power Electronics Device. *International Journal of Power Electronics and Drive System (IJPEDS)*. 2014; 5(2): 135-141.
- [10] Zabeli M, Caka N, Limani M, Kabashi Q. *The threshold voltage of MOSFET and its influence on digital circuits*. Recent Advances in Systems, Communications & Computers, Selected Papers from the WSEAS Conferences in Hangzhou, China, April 6-8, 2008.
- [11] Baibich MN et al. Giant Magnetoresistance of (001) Fe/(001) Cr Magnetic Superlattices. *Physical Review Letters*. 1998; 61: 2472-2475.
- [12] Wei HX, Qin QH, Ma M, Sharif R, Han XF. 80% Tunneling Magnetoresistance at Room Temperature for Thin Al-O Barrier Magnetic Tunnel Junction with CoFeB as Free and Reference Layers. *Journal of Applied Physics*. 2007; 101(9): 09B501-09B501-3.
- [13] Nickel J. Magnetoresistance Overview. Hewlett-Packard Company. Report Number: HPL-95-60. 1995.