

# Adaptive-Fuzzy Controller Based Shunt Active Filter for Power Line Conditioners

Karuppanan PitchaiVijaya\*, KamalaKanta Mahapatra

National Institute of Technology-Rourkela

India-769008, Telp 91-661-2476773, Fax 91-661-2462999

e-mail: karuppanan1982@gmail.com\*, kkm@nitrkl.ac.in

## Abstrak

Makalah ini menghadirkan pengendali logika fuzi (FLC) baru dengan tapis aktif shunt berbasis kalang terkunci fasa (PLL) untuk pengkondisi saluran listrik (PLCs) guna meningkatkan kualitas daya pada sistem distribusi. Tapis aktif ini diimplementasikan dengan inverter sumber tegangan (VSI) terkendali arus untuk mengkompensasi harmonik arus dan daya reaktif pada titik kopling bersama. Pulsa penyaklaran pengendali gerbang VSI berasal dari pengendali arus histeresis (HCC) fuzi adaptif dan metode ini menghitung lebar bidang histeresis secara efektif menggunakan logika fuzi. Lebar bidang ini dapat diatur berdasarkan kompensasi variasi arus, yang digunakan untuk mengoptimalkan frekuensi penyaklaran yang diperlukan dan memperbaiki tapis aktif secara substansi. Sisteem tapis daya aktif shunt ini diinvestigasi dan diverifikasi pada keadaan tunak dan transien pada kondisi beban tak linear. Tapis aktif shunt ini telah memenuhi standar harmonik yang direkomendasikan IEEE 519 and IEC 61000-3.

**Kata kunci:** tapis daya aktif, fuzi adaptif, pengendali arus, pengkondisi jaringan daya listrik, kualitas daya

## Abstract

This paper presents a novel Fuzzy Logic Controller (FLC) in conjunction with Phase Locked Loop (PLL) based shunt active filter for Power Line Conditioners (PLCs) to improve the power quality in the distribution system. The active filter is implemented with current controlled Voltage Source Inverter (VSI) for compensating current harmonics and reactive power at the point of common coupling. The VSI gate control switching pulses are derived from proposed Adaptive-Fuzzy-Hysteresis Current Controller (HCC) and this method calculates the hysteresis bandwidth effectively using fuzzy logic. The bandwidth can be adjusted based on compensation current variation, which is used to optimize the required switching frequency and improves active filter substantially. These shunt active power filter system is investigated and verified under steady and transient-state with non-linear load conditions. This shunt active filter is in compliance with IEEE 519 and IEC 61000-3 recommended harmonic standards.

**Keywords:** active power filter, adaptive-fuzzy, current controller, power line conditioners, power quality

## 1. Introduction

Many researchers focused on the power quality and custom power in the distribution and transmission systems because of widespread use of non-linear loads [1]. These non-linear loads lead to harmonic or distorted current and reactive power problems [2]. Traditionally passive L-C filters were used to mitigate harmonics; however it had demerits of aging and tuning, resonance, bulk size and also fixed compensation. Recently, active power filters (APF) or active power-line conditioners (APLC) proposed power-electronic equipment for solving these power quality problems [1-2]. The APF has the ability to compensate current-harmonics and reactive power simultaneously [3-4]. The controller is the most significant part of the APF and currently lot of research is being conducted [5]. Conventional PI and PID controllers have been used to estimate the reference current and control over the dc-bus capacitor voltage of the inverter [8-11]. However, these controllers require precise linear mathematical model of the system, which is difficult to obtain under parametric variations and load disturbances [6]. Recently, fuzzy logic controller (FLC) is used in power electronic systems for adjustable motor drives and active power filter applications [7]. For FLCs, it does not need accurate mathematical mode. It can handle non-linearity and is more robust than conventional controllers [8]

The effectiveness of active power filter depends on the design and characteristics of current controller [9]. There are various PWM-current control strategies proposed for active filter [10]. The hysteresis current controller has the highest rating among other control methods such as sinusoidal-PWM and triangular-current controller in terms of quick current controllability and easy implementation [9-10]. The advantages of fixed-HCC are simple design and unconditioned stability [11]. However, this control scheme exhibits several demerits, such as uneven switching frequency, possible to generate resonances and difficult to design the passive filter system. This unpredictable switching function affects the active filter efficiency and reliability [12]. Adaptive-hysteresis current controller overcomes these fixed-HCC demerits [13-14]. But adaptive-HCC is having more switching power losses due to high frequency and this problem is addressed by proposed adaptive-fuzzy-HCC. The Adaptive-Fuzzy HCC calculates the hysteresis bandwidth effectively with the help of fuzzy logic and reduces the switching power losses [15].

This paper presents a fuzzy logic along with PLL-synchronization controller based shunt active power filter for enhancing the power quality. The PLL can operate satisfactorily even under distorted and unbalanced system voltages. The shunts active current controlled voltage source inverter switching pulses are generated from proposed adaptive-fuzzy-hysteresis current controller. These shunt active power filter is validated and investigated under steady and transient-state conditions.

## 2. Research Method

The proposed control system consists of two parts: (1) reference current extractor using PLL synchronization with fuzzy logic controller, and (2) voltage source inverter switching control method using adaptive-fuzzy-hysteresis current controller.

### 2.1 Reference Current Extractor

The reference current is extracted from distorted line-current using PLL along with fuzzy logic controller. This control algorithm is based on sensing source voltage and current only (No need to sense load currents and compensation currents) that is reduced sensors and complexity.

#### 2.1.1 PLL Synchronization

The phase locked loop circuit is meant for operation under distorted and unbalanced voltages [1], [3]. This algorithm is based on the three-phase instantaneous active power expression  $p_{3\phi} = v_a i_a + v_b i_b + v_c i_c$ . The feedback signals  $i_a(\omega t) = \sin(\omega t)$  and  $i_c(\omega t) = \sin(\omega t + 2\pi/3)$  is built up on PLL-circuit and time integral  $\omega$  is calculated using proportional-integral gains. The PLL-circuit can reach a stable point when the input  $p_{3\phi}$  of the proportional-integral -controller has a zero average value ( $p_{3\phi} = 0$ ) and has minimized low-frequency oscillating portions in three-phase voltages. Once the circuit is stabilized, the average value of  $p_{3\phi}$  is zero and the phase angle of the supply voltage is at fundamental frequency. At this condition, the currents become orthogonal to the fundamental phase voltage component. The PLL synchronizing output templates are

$$pll_a = \sin(\omega t) \quad (1)$$

$$pll_b = \sin(\omega t - 2\pi/3) \quad (2)$$

$$pll_c = \sin(\omega t + 2\pi/3) \quad (3)$$

The PLL output is multiplied with fuzzy logic controller output (peak current  $I_{max}$ ) to determine the required reference current.

#### 2.1.2 Fuzzy Logic Controller

Fuzzy logic control is deduced from fuzzy set theory, transition is between membership and non membership function. Therefore, limitation or boundaries of fuzzy sets are undefined and ambiguous and useful for approximate systems design. In order to implement the fuzzy

logic control algorithm of an active power filter in a closed loop, the dc-bus capacitor voltage is sensed and then compared with the reference value. The compared error signal ( $e = V_{DC,ref} - V_{DC}$ ) allows only the fundamental component using the Butterworth 50 Hz Low Pass Filter (LPF). The error signal  $e(n)$  and integration of error signal or change of error signal  $ce(n)$  are used as inputs for fuzzy processing as shown in Figure 1.

The output of the fuzzy logic controller limits the magnitude of peak reference current  $I_{max}$ . The fuzzy logic controller characterized by: (1) seven fuzzy sets (NB, NM, NS, ZE, PS, PM, PB) for each input and output variables, (2) triangular membership function is used for the simplicity, (3) implication using mamdani-type min-operator, and (4) defuzzification using the height method.

**Fuzzification:** Fuzzy logic uses linguistic variables instead of numerical variables. In a control system, error between reference signal and output signal can be assigned as Negative Big (NB), Negative Medium (NM), Negative Small (NS), Zero (ZE), Positive Small (PS), Positive Medium (PM), Positive Big (PB). The process of fuzzification includes numerical variable (real number) conversion to a linguistic variable (fuzzy number).

**Rule Elevator:** Conventional controllers like PI and PID have control gains which are combination of numerical values. In case of fuzzy logic controller, it uses linguistic variables, instead of numerical. The basic fuzzy logic controller operation required for evaluation of fuzzy set rules are  $AND(\cap)$ ,  $OR(\cup)$  and  $NOT(-)$  for intersection, union and complement functions respectively, it is derived as

$$AND\text{-Intersection} : \mu_{A \cap B} = \min[\mu_A(X), \mu_B(x)]$$

$$OR\text{-Union} : \mu_{A \cup B} = \max[\mu_A(X), \mu_B(x)]$$

$$NOT\text{-Complement} : \mu_A = 1 - \mu_A(x)$$

**Defuzzification:** The rule of fuzzy logic generation requires output in a linguistic variable, according to real world requirements; linguistic variables have to be transformed to crisp output (Real number). This selection of strategy is compromised between accuracy and computational intensity.

**Database:** The database stores the definition of the triangular membership function required by fuzzifier and defuzzifier.

**Rule Base:** The rule base stores the linguistic control rules required by rule evaluator (decision making logic). The 49-rules used in this proposed controller are shown in Table 1. The output of the fuzzy controller estimates the magnitude of peak reference current  $I_{max}$ . This current  $I_{max}$  takes response of the active power demand of the non-linear load for harmonics and reactive power compensation. The peak current multiplied with PLL output to determine the required reference current.

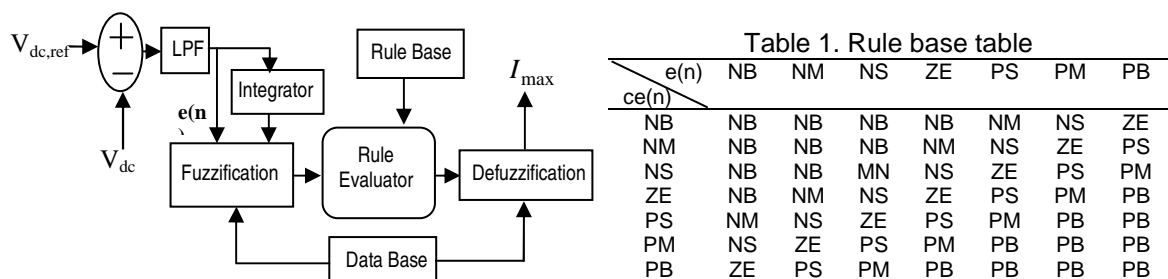

Table 1. Rule base table

e(n) \ ce(n)	NB	NM	NS	ZE	PS	PM	PB
NB	NB	NB	NB	NB	NM	NS	ZE
NM	NB	NB	NB	NM	NS	ZE	PS
NS	NB	NB	NM	NS	ZE	PS	PM
ZE	NB	NM	NS	ZE	PS	PM	PB
PS	NM	NS	ZE	PS	PM	PB	PB
PM	NS	ZE	PS	PM	PB	PB	PB
PB	ZE	PS	PM	PB	PB	PB	PB

Figure 1. Fuzzy logic controller

## 2.2 Adaptive-Fuzzy Hysteresis Current Controllers

The fixed-hysteresis current controller has unpredictable switching functions and affects the active filter efficiency and reliability. The adaptive-hysteresis current controller overcomes the fixed-HCC demerits. But adaptive-HCC has more switching power losses due to high frequency and this problem is addressed by proposed adaptive-fuzzy HCC. It calculates the hysteresis-bandwidth with the help of fuzzy logic and reduces the switching power losses. Figure 2 shows the PWM-voltage source inverter current and voltage waves for phase  $a$ . The current  $i_a$  tends to cross the lower hysteresis band at point 1, where the switch S1 is ON.

The linearly rising current ( $i_a^+$ ) then touches the upper band at point 2, where the switch S4 is switched ON. The linearly falling current ( $i_a^-$ ) then touches the lower band at point 3. The following equations can be written in the switching intervals  $t_1$  and  $t_2$  [12-13]

$$\frac{di_a^+}{dt} = \frac{1}{L}(0.5V_{dc} - V_s) \quad (4)$$

$$\frac{di_a^-}{dt} = -\frac{1}{L}(0.5V_{dc} + V_s) \quad (5)$$

From the geometry of Figure 2, we can write

$$\frac{di_a^+}{dt}t_1 - \frac{di_a^*}{dt}t_1 = 2HB \quad (6)$$

$$\frac{di_a^-}{dt}t_2 - \frac{di_a^*}{dt}t_2 = -2HB \quad (7)$$

$$t_1 + t_2 = T_c = 1/f_c \quad (8)$$

Adding (6) and (7) and substituting (8) we can write

$$\frac{di_a^+}{dt}t_1 + \frac{di_a^-}{dt}t_2 - \frac{1}{f_c} \frac{di_a^*}{dt} = 0 \quad (9)$$

Subtracting (7) from (8), we get

$$\frac{di_a^+}{dt}t_1 - \frac{di_a^-}{dt}t_2 - (t_1 - t_2) \frac{di_a^*}{dt} = 4HB \quad (10)$$

Substituting (5) in (10), we get

$$\frac{di_a^+}{dt}(t_1 + t_2) - (t_1 - t_2) \frac{di_a^*}{dt} = 4HB \quad (11)$$

Substituting (5) in (9), and simplifying,

$$(t_1 - t_2) = \frac{di_a^* / dt}{f_c (di_a^+ / dt)} \quad (12)$$

Substituting (12) in (11), it gives,

$$HB = \left\{ \frac{0.125V_{dc}}{f_c L} \left[ 1 - \frac{4L^2}{V_{dc}^2} \left( \frac{V_s}{L} + m \right)^2 \right] \right\} \quad (13)$$

Here,  $m = di_a^* / dt$  is the slope of reference current signals. From this equation (13), the hysteresis bandwidth  $HB$  is derived from the modulation frequency  $f_c$ , supply voltage  $V_s$ , dc-side capacitor voltage  $V_{dc}$ , slope of the reference current signals  $di_a^* / dt$  and decoupling inductance  $L$  of the active power filter. This adaptive-hysteresis bandwidth  $HB$  as an error signal  $E(HB)$  and change of error signal  $CE(HB)$  are used as inputs for fuzzy processing. The adaptive-fuzzy-hysteresis band  $HB'$  is the output of fuzzy controller that is shown in Figure 3. The fuzzy logic rule base stores the linguistic control rules required by rule evaluator. The 49-rules used in this controller as shown in Table 1.

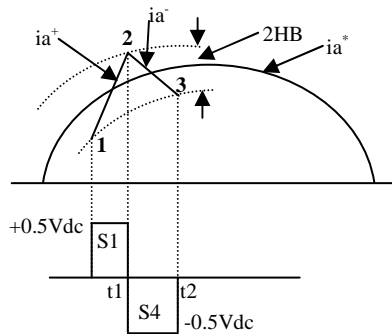

Figure 2. Adaptive hysteresis current controllers

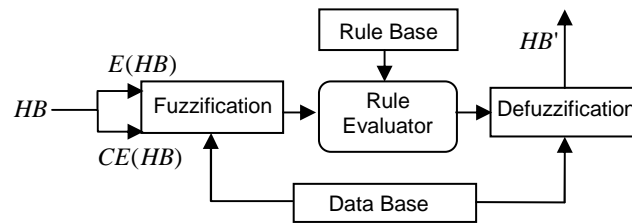

Figure 3. Fuzzy logic controllers

The output of fuzzy logic controller  $HB'$  (hysteresis bandwidth) can be modulated at different points of the fundamental frequency cycle to control the switching pattern of the voltage source inverter. The calculated hysteresis bandwidth  $HB'$  is applied to the variable HCC. The variable HCC is created by s-functions in Matlab to produce gate control switching pulses and these pulses will drive the inverter. For symmetrical operation of all three-phases, the hysteresis bandwidth  $HB'$  is denoted as  $HB'_a, HB'_b$  and  $HB'_c$  of same value, but having  $120^\circ$  phase difference. The adaptive-fuzzy-HCC based bandwidth  $HB'$  should maintain the modulation frequency constant. This controller reduces the switching power losses and improves the PWM performances for active power filter substantially.

### 3. Results and Discussion

The performance of the proposed adaptive-fuzzy-HCC method is evaluated through Matlab/Simulink power tools. The model system consists of a three-phase distorted supply voltage with a rectifier R-L load. The shunt active filter is connected in the distribution grid at PCC through filter inductance and operates in a closed loop. The three-phase active power filter comprises of six-power transistor with diodes, a dc-bus capacitor, RL-filter, compensation controller (PLL-circuit with FLC) and switching signal generator (adaptive-fuzzy-HCC) as shown in the Figure 4. The system parameters values are; Line to line source voltage is 440 V; System frequency (f) is 50 Hz; Source impedance of  $R_s, L_s$  is 1  $\Omega$ ; 0.1 mH; Filter impedance of  $R_c, L_c$  is 1  $\Omega$ ; 1 mH respectively; Diode rectifier  $R_L, L_L$  load: 20  $\Omega$ ; 100 mH respectively; DC-side capacitance ( $C_{DC}$ ) is 1200  $\mu F$ ; Reference voltage ( $V_{DC, ref}$ ) is 400 V; Power devices build by MOSFETs with freewheeling diodes.

#### Case1 Steady state

The system is tested under distorted supply voltages. The Figure 5 (a) indicates three-phase distorted source voltage. The PLL-circuit is used to synchronize the distorted voltages and generates balanced (regulated) instantaneous sinusoidal voltages  $pll_a, pll_b, pll_c$  that are shown in Figure 5(b).

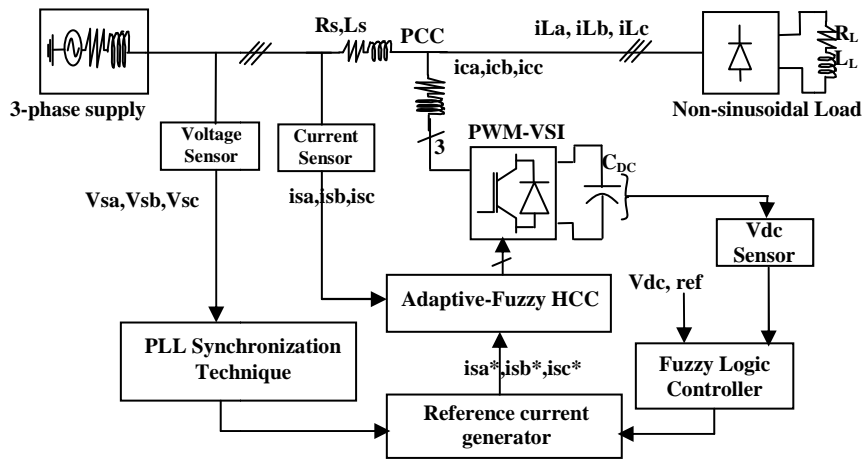

Figure 4. Shunt active power filter system

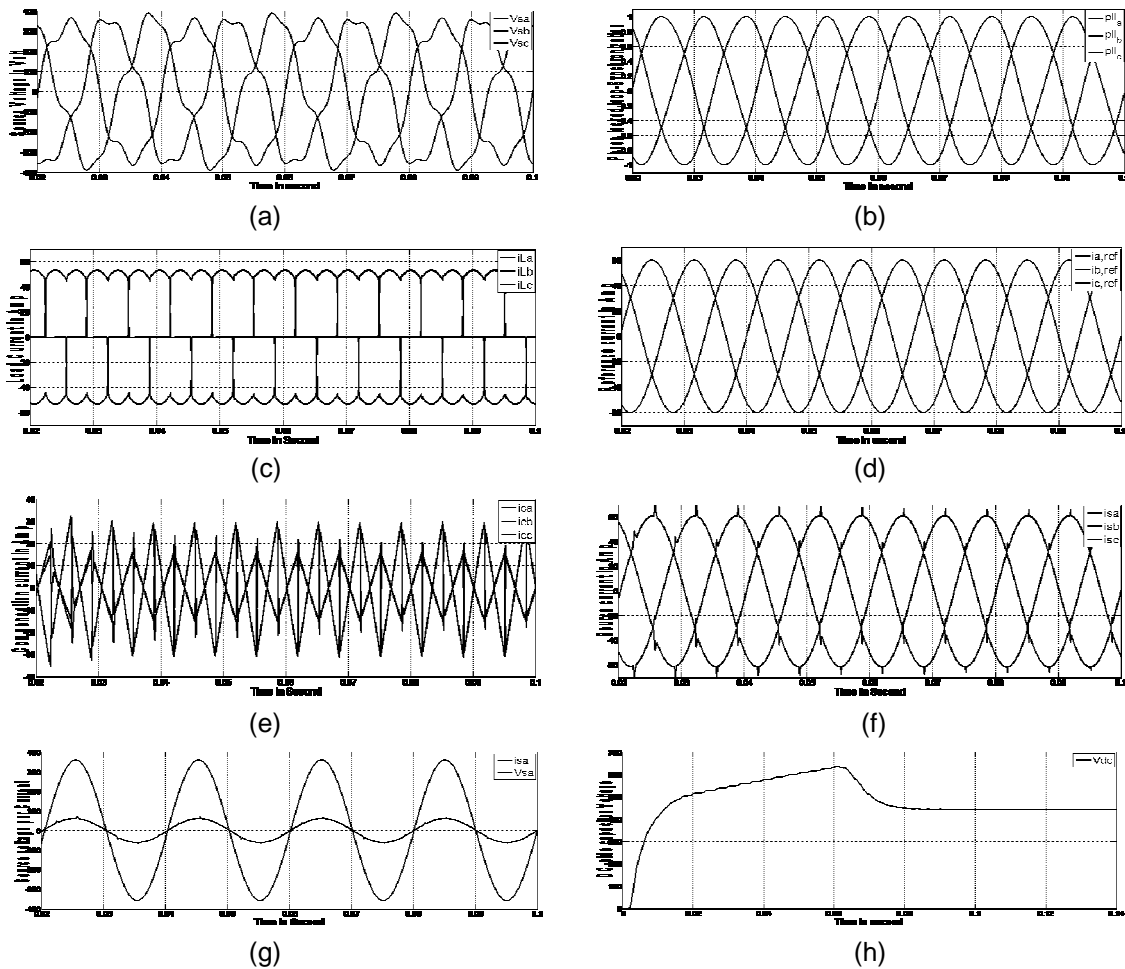

Figure 5. Simulation result; (a) distorted source voltage, (b) PLL-synchronization waveform, (c) Load current, (d) Reference current, (e) Compensation current, (f) source current, (g) unity power factor waveforms, and (h) DC-side capacitor voltage

These PLL outputs are in phase with the fundamental component of the the distorted/unbalanced source voltages. The source draws non-sinusoidal or harmonic current

due to the non-linear characteristics. The APF is connected in parallel at the PCC for compensating the harmonics and reactive power. The simulation result of the six-pulse diode rectifier load current or source current before compensation is shown in Figure 5 (c). The desired reference current is shown in Figure 5 (d); this current is obtained from PLL synchronization with fuzzy logic controller. The shunt active power filter supplies the compensating current that is shown in Figure 5 (e). The source current after compensation is presented in Figure 5 (f) that indicates the current is sinusoidal. It is achieved by injecting equal but opposite current harmonic components at PCC. APF is suppressing the reactive power and improves power factor as shown in Figure 5 (g), phase (a) voltage and current are in phase. The DC-side capacitance voltage is controlled by fuzzy logic controller (FLC). This controller reduces the ripple to certain level and makes settling time to a low value ( $t= 0.076s$ ) and it is plotted in Figure 5 (h).

*Case 2 Transient state*

For transient, the steady state suddenly changes to transient condition using step-size at  $T=0.08-0.14/0.2s$ . Similar waveforms are obtained and verified in transient simulation. The source current after compensation is presented in Figure 6 (a) that indicates the current becomes sinusoidal. The load current contains harmonics and fundamental components due to non-linear characteristics that are shown in Figure 6 (b). These current waveform are a particular phase (phase a). Other phases are not shown as they are only phase shifted by  $120^0$ .

The Fast Fourier Transform (FFT) is used to measure the order of harmonics with the fundamental frequency at 50 Hz of the source current. The magnitudes of the harmonics are plotted under non-linear load condition without/with APF and are shown in Figure 7.

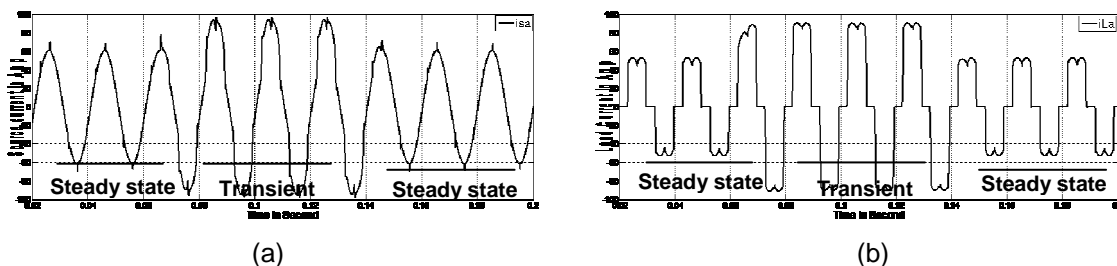

Figure 6. Simulation result (a) source current and (b) load current

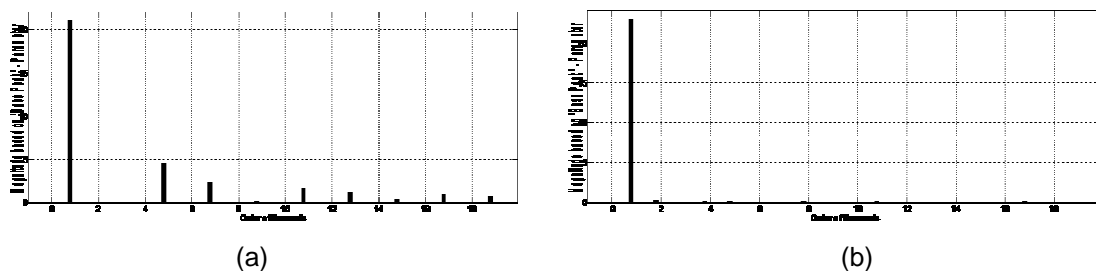

Figure 7. Order of harmonics (a) non-linear load condition; the source current without APF (THD=26.67%), (b) with APF (THD=2.04%)

The Real (P) and Reactive (Q) power is calculated and given in the Table 2. This result is measured under non-linear load condition using adaptive-fuzzy-hysteresis controlled shunt APF system. This result indicates the active power filter is suppressing the reactive power and improves the power quality in the distribution system at PCC. The total harmonic distortion (THD) measured from source current on the ac main network. The adaptive-fuzzy-FCC based compensator active filter made sinusoidal source current in the supply. THD is measured and compared as given in Table 3. The simulation is done distorted supply voltage with non-linear load conditions. The obtained results proof that source current and load current is small

variation in steady state and transient conditions. FFT analysis of the active filter brings the THD of the source current into compliance with IEEE and IEC standards harmonic.

Table 2. Real (P) and Reactive (Q) power measurement

Condition	Real (P) and Reactive (Q) power	
	Without APF	With APF
Steady state	P=10.11 kW	P=11.05 kW
	Q= 269 VAR	Q= 081VAR
Transient	P= 10.71 kW	P= 10.95 kW
	Q= 212 VAR	Q=092 VAR

Table 3. FFT analysis of Total harmonic distortion (THD)

Condition(THD)	without APF	with APF
Steady state	26.67 %	2.04 %
Transient	26.33 %	2.45 %
Power factor	0.9677	0.9999

## 5. Conclusion

The investigation demonstrates a fuzzy logic controller in conjunction with the PLL-synchronizing circuit active power filter. The FLC ensures that the dc-side capacitor voltage is nearly constant with small ripple besides extracting fundamental reference currents. The PLL-circuit assists the APF to function even under distorted/unbalanced voltage conditions. The shunt APF is implemented with current controlled voltage source inverter and is connected at PCC for compensating the current harmonics and reactive power. The VSI gate control switching pulses are derived from adaptive-fuzzy-hysteresis current controller. The adaptive-fuzzy-HCC changes the bandwidth based on instantaneous compensation current variation. The proposed controller based active power filter performs perfectly under steady-state and transient conditions. Important performance parameters have been presented graphically. This approach brings down the THD of the source current to become 2.04 % under non-linear load that is in compliance with IEEE-519 and IEC 61000-3 standards.

## References

- [1] Akagi H, Watanabe EH, Aredes M. Instantaneous power theory and applications to power conditioning. New York: IEEE-press. 2007: 43-220.
- [2] Duffey CK, Stratford RP. Update of Harmonic Standard IEEE-519: IEEE Recommended Practices and Requirements for Harmonic Control in Electric Power Systems. *IEEE Trans on Industry Applications*. 1989; 25(6): 1025-1034.
- [3] Monteiro LFC, Costa JCC, Aredes M, Afonso JL. *A Control Strategy for Unified Power Quality Conditioner*. Brazilian Power Electronics Conference. Recife, Brazil. 2005.
- [4] Salam Z, Cheng TP, Jusoh A. Harmonics Mitigation Using Active Power Filter: A Technological Review. *ELEKTRIKA*. 2006; 8(2): 17-26.
- [5] Nabae A, Ogasawara S, Akagi H. A Novel Control Scheme for Current-Controlled PWM Inverters. *IEEE Transaction on Industry Applications*. 1986; 1A-22(4): 562-570.
- [6] Jain SK, Agrawal P, Gupta HO. Fuzzy logic controlled shunt active power filter for power quality improvement. *IEE Proc. Electric Power Applications*. 2002; 149(5): 317-328.
- [7] Saad S, Zellouma L. Fuzzy logic controller for three-level shunt active filter compensating harmonics and reactive power. *Electric Power Systems Research*. 2009; 79(10): 1337-1341.
- [8] Raviraj VSC, Sen PC. Comparative Study of Proportional-Integral, Sliding Mode, and Fuzzy Logic Controllers for Power Converters. *IEEE Trans on Industry Applications*. 1997; 33(2): 518-524.
- [9] Kaunierkowski MP, Dzieciakowski MA. *Review of Current Regulation Techniques for Three-phase PWM Inverters*. Conference on IECON-94. Bologna, Italy. 1994; 1: 567-575.
- [10] Brod DM, Novotny DM. Current control of VSI-PWM Inverter. *IEEE Trans on Industry Appl*. 1985; IA-21(3): 562-570.
- [11] Zeng J, Yu C, Qi Q, Yan Z, Ni Y, Zhang BL, Chen S, Wu FF. A novel hysteresis current control for active power filter with constant frequency. *Electric Power Systems Research*. 2004; 68(1): 75-82
- [12] Bose BK. An Adaptive Hysteresis-Band Current Control Technique of a Voltage-Fed PWM Inverter for Machine Drive System. *IEEE Trans on Industrial Electronics*. 1990; 31(5): 402-408
- [13] Kale M, Ozdemir E. An adaptive hysteresis band current controller for shunt active power filter. *Electric Power Systems Research*. 2005; 73(2): 113-119.
- [14] Belhaouchet N, Rahmani L. Development of Adaptive Hysteresis-band Current Control of PWM Three-Phase AC Chopper with Constant Switching Frequency. *Electric Power Components and Systems*. 2009; 33(10): 583-598.
- [15] Kadjoudj M, Abdessemed R, Golea N, Benbouzid ME. Adaptive Fuzzy Logic Control for High Performance PMSM Drives. *Electric Power Components and Systems*. 2001; 29(9): 789-807.