

Design and Simulation of Small Space Parallel Parking Fuzzy Controller

Qiulin Sheng^{*1}, Jie Min², Xing Zhang³, Zhengwen Zhang⁴, Yi Li⁵, Guangya Liu⁶

College of Electrical and Electronic Engineering, Hubei University of Technology, Wuhan,
430068, Hubei Province, China

*Corresponding author, email: sql103@qq.com¹, mj904820557@163.com², 645371519@qq.com³,
669037364@qq.com⁴, 1029519940@qq.com⁵, whltxz@aliyun.com⁶

Abstract

Based on the nonlinearity and time-variation of automatic parking path tracking control system, we use fuzzy control theories and methods to explore the control rules to improve fuzzy controllers and design an automobile steering controller. Then we build the simulation experiment platform of an automobile in Simulink to simulate the reversing settings of parallel parking. This paper adopts the Mamdani control rules; the membership function is the Gauss function. This paper verifies the fuzzy controller's kinematic model and the advantages of fuzzy control rules. Simulation results show that the design of the controller allows the automobile to stop into the parking space smaller than the space obtained by planning path, and automatic parking becomes possible in the parking plot. The control system is characterized by small tracking error, fast response and high reliability.

Keywords: Parallel Parking, Fuzzy Control, Matlab Simulation

1. Introduction

The purpose of this study is to improve the control scheme of intelligent automobiles so that in reversing the smart automobile can be more close to the ideal reversing trajectory and it can stop into a small parking space. This technology can ease traffic pressure and enhance the safety performance of vehicles. Automatic parking technology is currently one of the most popular smart technology, which has attracted the attention of many researchers. There are two the most classic approaches [1]-[2]: (1) By path planning method, which previously was given a geometric path, combined with the car's dynamic model and parking restrictions generation control strategies, this is a research path tracking control of the vehicle based on the visual environment that has been more mature [3]-[4]. (2) Based on skill acquisition methods, which by fuzzy logic or neural networks [5], learning more skilled people parking technology transferred to the automatic parking controller. This method is not designed reference path, which control strategies was implemented to control the position and orientation angle according to the car in the parking. This paper studies fuzzy logic control method. On the basis of previous studies, we will design a fuzzy controller that was optimized its fuzzy control rules to control the car so that it can achieve a more ideal control performance, including the control precision and the minimum size of parking spaces and parking time.

2. Kinematic Model of Car Parallel Parking

2.1. Detection of Car Parking Spaces

Before the car automatically stopping into the parking spaces, it must be detected around the parking spaces. The image sensor or ultrasonic sensor is installed around car to detect the parking spaces. For example, the image sensor photographed scenery around, combined with an algorithm, the car can identify parking spaces. The irregular spaces tuning as a rule rectangular spaces in Figure 1. If the parking space is large enough, the parking spaces will be the parking space of smart car. Tables and Figures are presented center, as shown below and cited in the manuscript.

2.2. The Establishing Reversing Model of Car Established

2.2.1. The Ackerman angle of motor two wheels in actual movement

In order to simplify the reverse model of the car, the car side-slip won't be considered and the parking speed is very low. Car wheels in the rotation follow the principle of Ackerman [13] angle as Figure 2.

Two corners of car two wheels computation equations are shown in the following:

$$\begin{cases} \tan \delta_{in} = \frac{L}{R_{in}} \\ \tan \delta_{out} = \frac{L}{R_{out}} \\ R_{in} + B = R_{out} \end{cases} \quad (1)$$

According to equation (1), following equation will be came about δ_{in} and δ_{out} :

$$\frac{\tan \delta_{in}}{\tan \delta_{out}} = \frac{R_{in} + B}{R_{in}} \quad (2)$$

There is a relationship of formula (2) of the two wheels rotational angle in the actual movement.

But in order to simplify the model, a unified Ackerman angle will be defined as ϕ , which is midpoint rotational angle of car front axle following Fig.3.

This ϕ angle will be used for the mathematical model behind. The angle of the two wheels Ackerman angle has a certain relationship with the ϕ . The equations are shown in the following:

$$\begin{cases} \tan \phi = \frac{L}{R} \\ R = R_{in} + \frac{B}{2} \end{cases} \quad (3)$$

According to front equations (1), (2), (3);

$$\frac{\tan \delta_{in}}{\tan \delta_{out}} = \frac{\frac{L}{\tan \phi} + \frac{B}{2}}{\frac{L}{\tan \phi} - \frac{B}{2}} \quad (4)$$

2.2.2. Car reversing model under the simplified model

Two wheels of car were controlled with two motors and two control chips respectively in the paper, and wheels rotational angle were determined by the Ackerman angle. In building model, Ackerman angle was represented with ϕ in the paper. Automatic parallel parking algorithm is based on kinematic model of the car. In building kinematic model of the car, first of all model parameters need to be determined. For example, the coordinate of the center of the car is (x, y), the symbol of v represents speed of car, the symbol of v_l represents speed of left wheel of car and the symbol of v_r represents speed of right wheel of car. The θ represents

angle between X-axis and central axis of car. The $\dot{\theta}$ represents slip of car that is the rate of change of θ . Every time the travel trajectory of rear has important relationship with distance of wheels and axle, and Ackerman angle of the center of front axle. The speed of car have no influence on the travel trajectory [2]-[3].

Kinematic equation of car are shown in the following:

$$\begin{cases} \theta(i+1) = \theta(i) + \dot{\theta}(i) dt \\ x(i+1) = x(i) + v(i+1) \cos(\theta(i+1)) \\ y(i+1) = y(i) + v(i+1) \sin(\theta(i+1)) \end{cases} \quad (5)$$

Speed equation of car left and right wheels are shown in the following:

$$\begin{cases} \dot{\theta}(i) = \frac{v_r(i) - v_l(i)}{2} \\ v(i) = \frac{v_r(i) + v_l(i)}{2} \end{cases} \quad (6)$$

In each sample period, the car can obtain the rotational speed of the left and right wheels by the above equations.

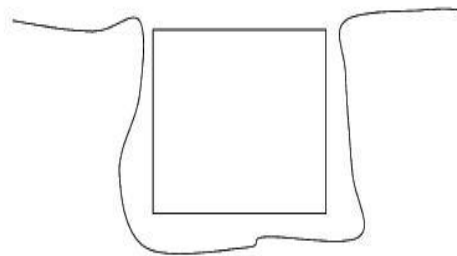

Detection an determination the car parking spaces

Figure 1. Detection an determination the car parking spaces

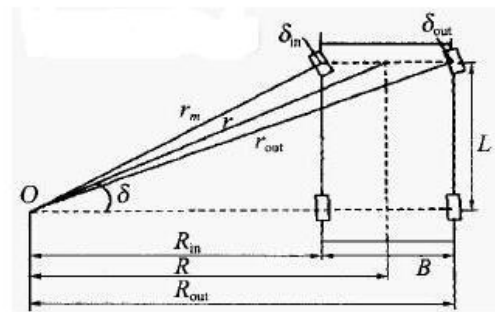

Figure 2. The model of Ackerman angle

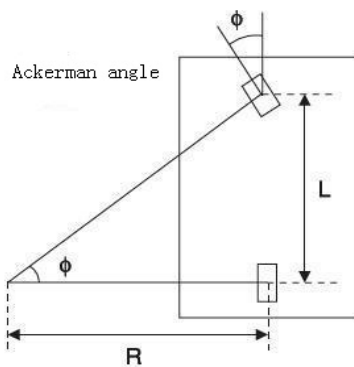

Figure 3. Ackerman angle of car

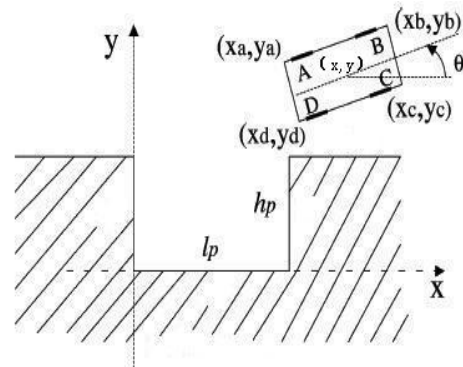

Figure 4. The reversing model of car

3. The Design of Controller of Car

Fuzzy controller is the core of Fuzzy control system, and the design of Fuzzy controller directly affects the accuracy of final control outcome. The design of the controller should apply moderate principles that represent not only high accuracy, but also simplified fuzzy inference operation relatively. Because complex control system will lead to delayed response of system that can have an influence on real-time control of car that will decrease accuracy of control in turn [8].

3.1. The Block Diagram of Fuzzy Controller

The blur represents that the precise digital variable changes into fuzzy variable. The process of fuzzy inference presents that according to the fuzzy rule base, and the database has been established, the fuzzy inputs are processed to generate the corresponding control inputs and control strategy. Anti-blur process represents that the fuzzy outputs change into precise numeric variables, which were used to control output object.

3.2. Block Diagram of the Fuzzy Controller

The main differences between fuzzy control system and ordinary computer numerical control system is the use of a fuzzy controller. The performance of a fuzzy controller is decided these factors that are the structure of the fuzzy controller, synthetic reasoning algorithms and fuzzy control rules. The basic block diagram of the fuzzy control as Figure 6 shown, the fuzzy controller is the its core ,and fuzzy controller control rules is implemented by a computer program. Implementation process of fuzzy control algorithm is described as follows: firstly, computer obtain the precise value of controlled variables by the interrupt sampling, then this value compares with a given variable to obtain a difference of signal E, as an input; secondly, the accurate difference of signal E change into blur, and using appropriate language represents the difference E, then based on the synthesis of rule-based reasoning, combined with the fuzzy relation R obtains fuzzy control volume. computation equations are shown in the following: $u = e \circ R$.

3.3. The fuzzy Controller Design

Because the process of reversing is very complex, we need to design a complex fuzzy controller so that the car can be controlled precisely. The length of the vehicle is defined in 4m, and the width is 1.6m; the center position coordinate of the vehicle is set (x, y), and the ordinate represents the distance from the car to the parking space. Fuzzy controller has three inputs x, y, and θ in the process of reversing; and a output $\dot{\theta}$ equal to the rotation angle of wheels approximately. This three-dimensional fuzzy controller to control have a total of 18 rules. The variables membership function are shown in the Figure 7, Figure 8, Figure 9, Figure 10. In this paper, Mamdani control rules were used, and membership functions use Gaussian function[9].

The control rules of fuzzy controller were shown in Table 1:

On the part of the fuzzy rules of parallel parking will be explained as follows:

If x is S, and y is S, it means that the car has been reversed into the parking. When θ is N, it means that angle of direction of the vehicle at this time is a negative value, the direction of the vehicle need to be straightened rapidly.

If x is S, and y is S, it means that the car has been reversed into the parking. When θ is Z, it means that angle of direction of the vehicle at this time is zero, then reversing the process of the car ends.

If x is B, y is B, and θ is P, it means that the car has reached the outside of parking spaces, and ready to into the parking spaces; then the direction of the angle of the car is positive, and it began to turn the steering wheels to the right making the car back to the parking space.

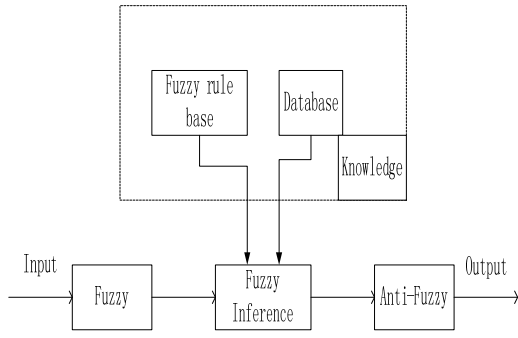

Figure 5. The block diagram of Fuzzy controller

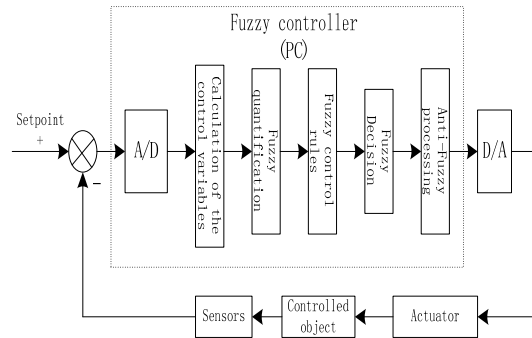

Figure 6. Block diagram of the fuzzy controller

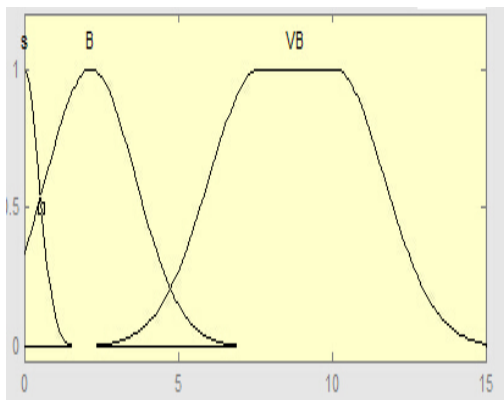

Figure 7. Membership function of x coordinate of the car

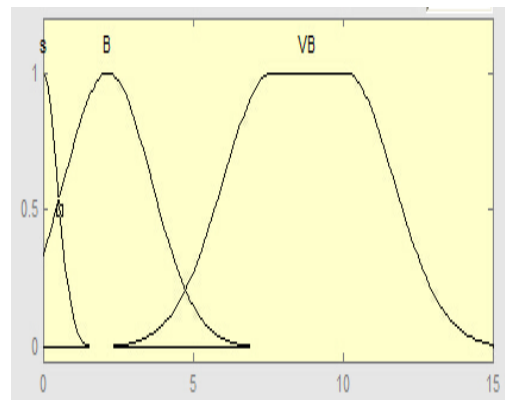

Figure 8. Membership function of y coordinate of the car

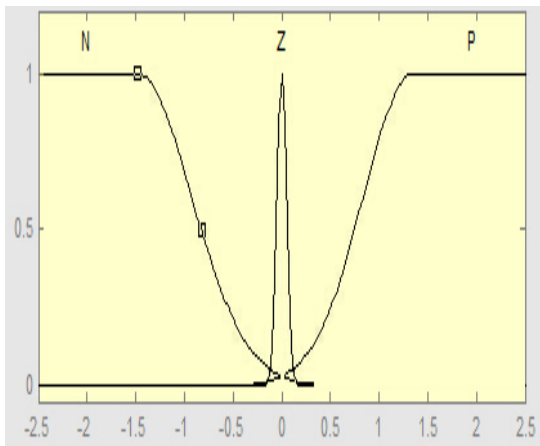

Figure 9. Membership function of the direction angle

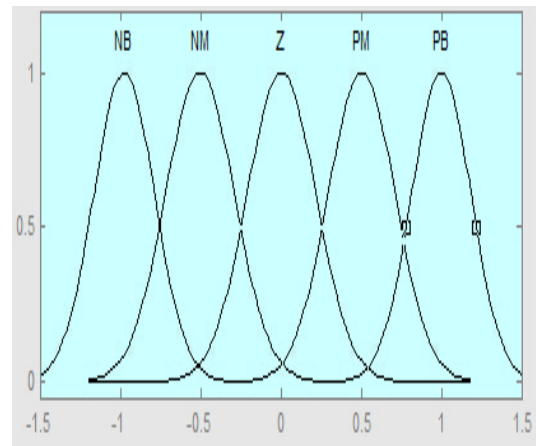

Figure 10. Membership function fuzzy controller output

Table 1. The control rules of fuzzy controller

	x/y	S	B	VB
$\theta=N$	S	PB	PB	
	B	PM	PB	PB
	VB			PM
$\theta=Z$	S	Z	Z	
	B	Z	PB	PB
	VB			Z
$\theta=P$	S	NB	Z	
	B	NM	Z	PM
	VB			NB

4. Simulink Simulation Module Structures

The length of the vehicle is set to 4m, the width is set to 1.6m, and the vehicle speed is set to 5m/s [10] in simulation; there are three fuzzy controller input u (1), u (2), Controller, which are x coordinate, y coordinate, and the direction θ of the vehicle respectively; a fuzzy controller input represents changed rate of the angle direction of the vehicle. S-function module of parking are used handling real-time image display and obstacle avoidance in parking process. truck kinematic modules is subroutine module for the mathematical model of the truck; other modules are some of the auxiliary module in simulation. Nesting of fuzzy logic controller : based on front the fuzzy control rules specify the format FIS files embedded into the fuzzy controller in three steps [9],[11]:

- (1). Using MATLAB command readfis in the MATLAB main window, type: new file name = readfis ('file-name') Enter.
- (2). Using the mouse in the FIS editor: Type "fuzzy file-name" in the MATLAB main window, then the file will be sent to the MATLAB work-space.
- (3). Double-click the fuzzy controller of being nested, and by modifying the parameter name, it was changed to "new file name". After nested Controller, we will inspect the fuzzy controller to verify available. Right key-fuzzy controller, and select "look under mask", if the fuzzy controller shows FIS, it represents nesting success; if the display is sffis, it represents not nesting success when the fuzzy controller should be re-nested until Show FIS.

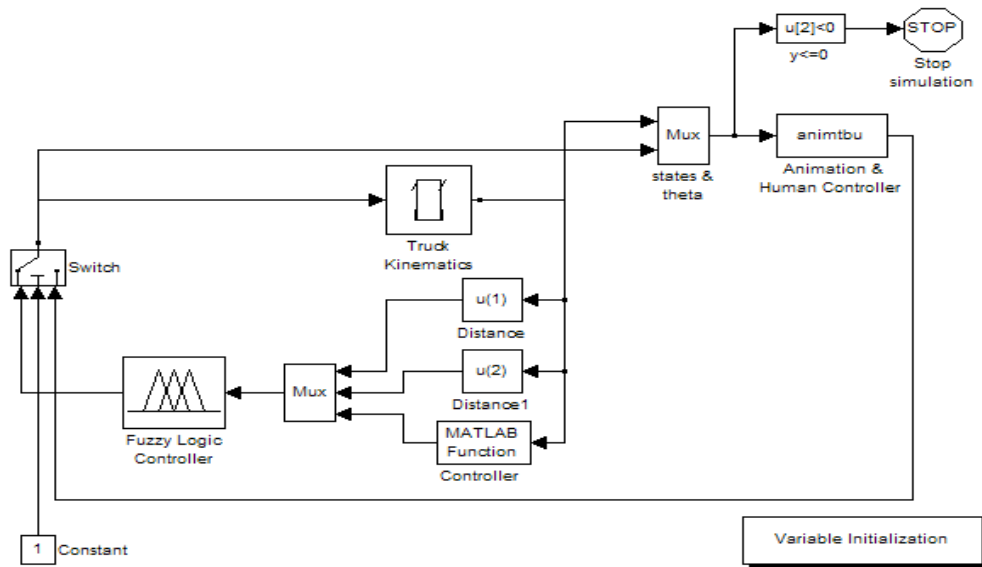

Figure 11. Simulink simulation module structures

5. Simulink Simulation Results

1. In the following three Figure 12, the dynamic processes of reversing parking were simulated in different starting points that are coordinates (10.5, 3.5), (10.5, 4.0), and (10.5, 4.5) respectively. From the three coordinates We can find that they have difference y-coordinates. Based on Figure 13, when the pitch is the best distance, the longitudinal distance have no influence on automatic parking but making the minimum parking space larger [12].

2. On the basis of the best starting point, according to the reverse path geometry constraint between the car and the parking space obtains a method of steering control strategy, whose the simulation results are shown in Figure 14.

3. On the basis of the best starting point, the simulation results of the fuzzy control algorithm was shown in Figure 15.

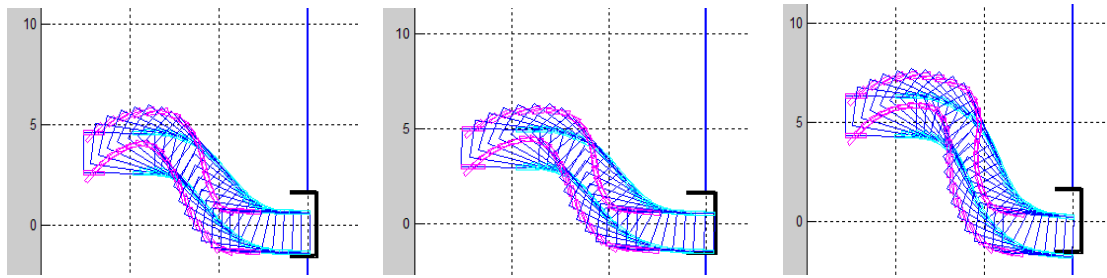

Figure 12. The reversing process

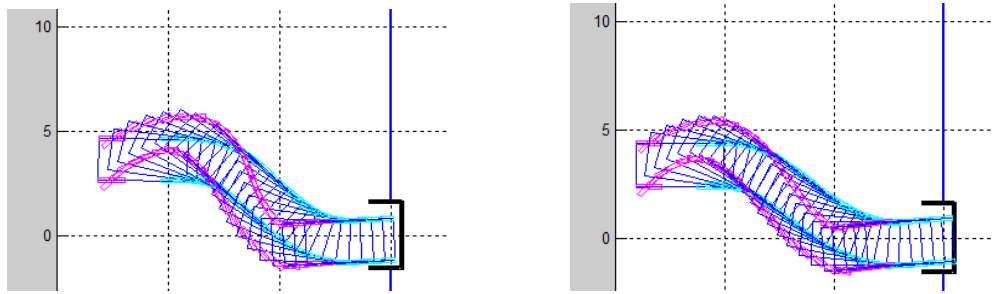

Figure 13. The reversing process

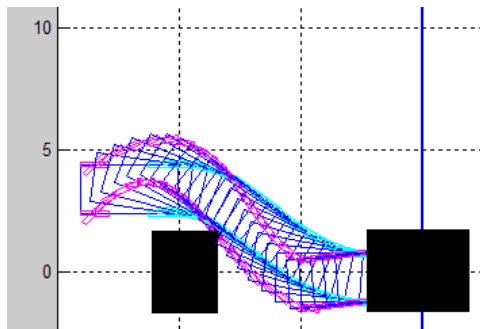

Figure 14. The reversing process on the basis of path planning

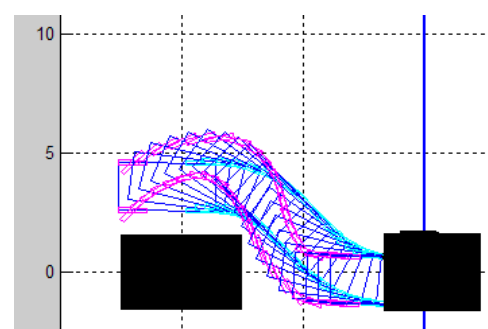

Figure 15. The reversing process on the basis of fuzzy Control

6. Simulation Analysis

According to the simulation results in Figure 12, it can be seen that the smaller distance between the car and the obstacle is more standard trajectory. So the best vertical distance is 0.5m. On the basis of the best starting point of the reverse, the same 6m parking, Figure 14 shows the path-based control method cannot make the car safely stop into parking spaces, but Figure 15 based on the fuzzy control simulation results show that cars can safely stop into the parking space.

7. Conclusion

This paper studies the parking situation at low speeds, analyzes several steps in parallel parking, simplifies parking steps of the vehicle model, and abstracts parking process parameters, and researches the theory of fuzzy control. Fuzzy control is applied to the parallel automatic parking system. The input, output and the fuzzy control rules are designed in the process design of parking. We can draw that the controller designed in this paper can basically meet the parking demand. The parking space where the car can be parked has become smaller. The trace has higher control precision, which is better than that of path planning method. However, we can know from the simulation results that the controller design is an important aspect, but selecting a starting point is also essential to successful parking, so that only two parts must cooperate to make the car enter parking spaces safely. But in the actual process of reversing the situation would not be so idealistic, in order to make it control real vehicle, the controller needs further improvement.

Acknowledgements

The research is funded by Wuhan Fundamental Applied Research Project, No.2013012401010 845, BSQD Fund Research Project, No. BSQD12023, and science and technology support program of Hubei Province, No.2014BAA135

References

- [1] Yanan Z, Emmanuel GC Jr. Robust automatic parallel parking in tight spaces via fuzzy logic. *Robotics and Autonomous Systems*. 2005; 51: 111-127.
- [2] Jiang H, Guo KH, Zhang JW. Design of automatic parallel parking steering controller based on path planning. *Journal of Jilin University (Engineering and Technology Edition)*. 2011; 41(2): 293-297.
- [3] Yuehai W, Ning C. Path Planning Optimization for Teaching and Playback Welding Robot. *TELKOMNIKA Indonesian Journal of Electrical Engineering*. 2013; 11(2): 960-968.
- [4] Yan X, Wu Q, Liu H. An Improved Robot Path Planning Algorithm Based on Genetic Algorithm. *TELKOMNIKA Indonesian Journal of Electrical Engineering*. 2012; 10(8): 1948-1955.
- [5] Tie W, Long Q, Hong C, Jing W. Simulate Study of Automatic Parking System. *TELKOMNIKA Indonesian Journal of Electrical Engineering*. 2013; 11(12): 7324-7330.
- [6] Gillespie TD. *Fundamentals of Vehicle Dynamics*. SAE International. 1992.
- [7] Wu RH, Zhang GR. Derivation and experimental verification of the vehicle trajectory for backward motion. *Mechanical and Industrial Management*. 2006; 274: 94-102.
- [8] Liu JK. *Intelligent Control*. Publishing house of electronics industry. 2005.
- [9] Shi XM, Hao ZQ. *Fuzzy control and MATLAB simulation*. Tsinghua University Press. 2008.
- [10] Wang P. Study on Parallel Parking System Based on Fuzzy Logic Control. *Journal of Jiamusi University (Natural Science Edition)*. 2012; 30(1): 28-37.
- [11] Zhang JR, Wang L. Fuzzy control simulation system based on MATLAB. *Zidonghua Yu Yiqi Yibiao*. 2003; 150(1).
- [12] Wu B. *Research on path simulation and motion control for automatic parking*. HeFei University of Technology. 2012.
- [13] Verónica SR, Francisco RM, Ishani C, José MMHR. Estimation of Ackerman angles for front-axle steered vehicles. *Artificial Intelligence Research*. 2013; 2(2): 18-27.