

INFORMATION TECHNOLOGIES

UDC 681.2.681.3

DOI 10.18372/2306-1472.76.13157

Vagif Abbas Abbasov

ALGORITHMIC METHODS OF LINEARIZATION CHARACTERISTICS
OF MEASURING SYSTEMS TRANSFORMATION

Azerbaijan State University of Oil and Industry,
Azadlig avenue, 20, Baku, Azerbaijan, AZ-1010
E-mail: vaqif_abbas@mail.ru

Abstract

There are technological, constructive, circuit, structural, structural-algorithmic and algorithmic methods of linearizing the MS transformation characteristic [1,2,3,4]. Only algorithmic methods based on the processing of measurement information obtained from the measuring system (MS) can meet the requirements for linearization requirements, such as eliminating the need for using high-precision model measures and not involving the measured value from the input of the MS and interference in the structure and principles of their construction. Known algorithmic linearization methods require reproduction of a non-linear function, an inverse of the MS transformation function, or a non-linear correction function. The article considers the proposed methods of linearization excluding the need to reproduce nonlinear functions that differ in their applicability to a wide class of nonlinear characteristics, without limiting the degree of their nonlinearity, which are based on the introduction of analytically determined and memorized microprocessor numerical corrections into the measurement result for each section of the fragmentation of the MS transformation characteristic. Depending on the carried out computational operations, these methods are called "additive" (summation or subtraction), "multiplicative" (multiplication), "additive-multiplicative" (summation and multiplication within one section), "combined: (in some sections multiplication, and in others-summation).

Keywords: additive; additive-multiplicative; combined; correction; measuring system; measuring instruments; multiplicative; linearization; transformation function

1. Introduction**Problem statement**

Measuring instruments designed to work as part of information measuring systems or with digital measuring instruments lead to increased demands with regard to the linearity of their transformation characteristics. This is due to the fact that the non-linearity of the transformation characteristic of measuring instruments leads to the appearance and accumulation of additional errors in further linear transformations, complicates the algorithm for determining and representing the value of the input quantity in units of its measurement.

The problem of linearization concludes in reducing the nonlinear part to such a value that, with an admissible error, the transformation characteristic of the measurement systems (MS) could be represented as a linear function.

In order to combine linearization operations and represent the result of digital measurement of the input quantity in its measurement units, it is necessary to approximate the MS transformation characteristic to a linear characteristic with a coefficient equal to unit, for example, $z = x$.

Analysis of recent research and publications

There are technological, constructive, circuit, structural, structural-algorithmic and algorithmic methods of linearizing the MS transformation characteristic [1,2,3,4].

Technological, constructive, circuit, structural and structural-algorithmic methods do not meet the requirements for linearization of nonlinear characteristics of MS without the need for using high-precision model measures and disconnecting the measured quantity from the input and interference in the structure and principles of MS

construction, especially with sensors of non-electrical quantities [1,2,3].

Only algorithmic methods based on the processing of measurement information obtained from the MS and not involving the introduction of additional functional blocks or elements into its structure can meet the abovementioned requirements.

Formulating the purpose of the article

The purpose of the article is to propose algorithmic methods of linearization, based on the processing of measurement information, characterized by their applicability to a wide class of nonlinear transformation characteristics, without limiting their degree of nonlinearity.

2. Statement of the main material

The introduction of microprocessors in the structure of measuring devices increases the possibility of using algorithmic methods to improve their metrological characteristics and expand their functional capabilities.

One of the most common algorithmic methods of linearizing the nonlinear characteristic of the MS transformation $Z = F(X)$ is the method of the reciprocal nonlinear transformation. The basis of this method is the following relation:

$$F^{-1}(Z) = F^{-1}[F(X)] = X \quad (1)$$

Here, X is the measured quantity; $F(X)$ is nonlinear characteristic of the measuring instrument transformation; $F^{-1}(Z)$ is the inverse nonlinear transformation of the output value of the MS.

As it is seen from equation (1), the application of this method involves performing a nonlinear transformation operation over the output value of the MS [4].

Another algorithmic method of linearization is based on the introduction of the nonlinear correction function $\Delta Z(X) = F(X) - X$, obtained as the difference between the nonlinear $Z = F(X)$ and the desired linear function of the transformation $Z^* = X$ to the output quantity of the MS:

$$F(X) - \Delta Z(X) = F(X) - [F(X) - X] = X \quad (2)$$

As it is seen from equations (1) and (2), the known algorithmic methods of linearization require the reproduction of a non-linear function, the inverse

of the MS transformation function or the non-linear difference function. In addition, the implementation of the second method is much more complicated in cases of intersection of the nonlinear and desired linear characteristics due to the difference in signs of the difference function before and after the intersection point.

The article considers the proposed methods of linearization, eliminating the need for reproducing non-linear functions, which are based on the introduction of the analytically determined and memorized measurement result into microprocessor of the numerical corrections for each section of the MS fragmentation characteristic.

The essence of these methods of linearization is as follows.

The nonlinear characteristic of the transformation of MS $Z = f(X)$ is divided into sections according to the method developed by the author, for which the numerical values of the corrections (P_i) are determined analytically by taking into account the deviations of the nonlinear and desired linear characteristics ($Z^* = X$) at the boundaries of the fragmentation sections (Z_i), which are introduced into the measurement result of the MS (Fig. 1).

Depending on the computational operations carried out to introduce the result measurement of corrections, these methods are called "additive" (summation or subtraction), "multiplicative" (multiplication), "additive-multiplicative" (multiplication and summation within one section), "combined" (in some sections multiplication, and in others - summation).

Being adjusted for various methods of linearization, the sections of the nonlinear characteristic of the MS take the types shown in Fig. 1.

A is the section of the nonlinear characteristic after correction by the additive linearization method obtained by subtracting from the output value of the MS of the correction, A_i is a constant value within the i^{th} section of the fragmentation:

$$Z_K^A = Z - A_i$$

Z_K^A is the output value of the MS adjusted by the additive method.

M is the section of the nonlinear characteristic after correction by the multiplicative method linearization obtained by multiplying the output value of the MS by a constant M_i of the i^{th} section of the fragmentation:

$$Z_K^M = Z \cdot M_i$$

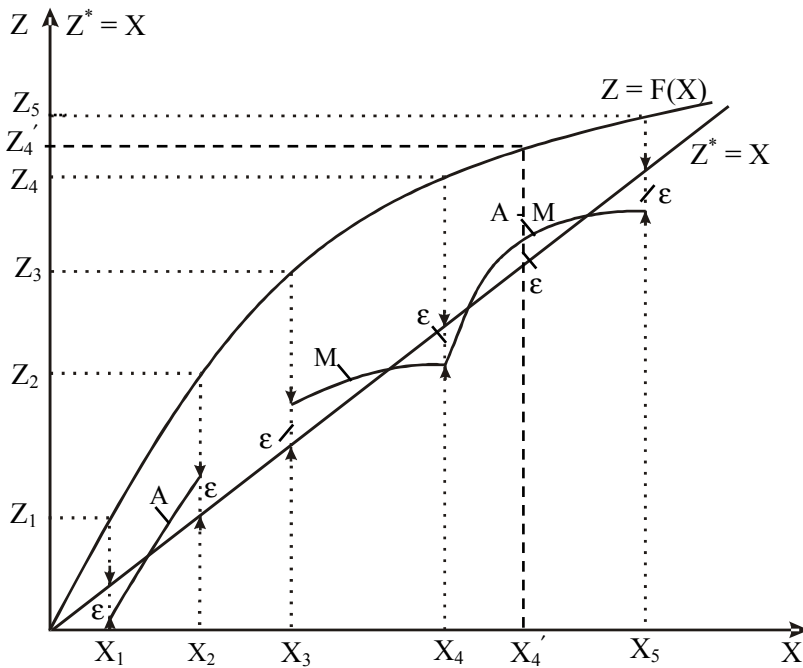

Fig.1. Geometric interpretation of linearization methods

Z_K^M is the output value of the MS adjusted for the multiplicative method. A-M is the non-linear characteristic section after the correction by the additive-multiplicative method of linearization, obtained by multiplying the output value of the MS by the coefficient C_i , and then subtracting the correction D_i from the multiplication result within the i^{th} section of the fragmentation:

$$Z_K^{A-M} = Z \cdot M_i - D_i$$

Z_K^{A-M} is adjusted by the additive-multiplicative method of output value of MS; ϵ is the maximum value of the deviations at the boundaries of the fragmentation sections of the adjusted part of the nonlinear characteristic from the linear characteristic.

The generalized mathematical model of the linearization process has the following form:

$$Z_K = \omega_i(Z) \cdot I(\text{CP}; \Pi_i; Z)$$

$\omega_i(Z)$ is a logical function: if the condition is $Z \in [Z_{i-1}; Z_i]$, $\omega_i(Z) = 1$, then $\omega_i(Z) = 0$

P_i is the correction introduced into the output value of the measuring system within the i^{th} section of fragmentation characteristics.

$I(\text{CP}; \Pi_i; Z)$ indicates the implementation of computational operations between the correction P_i and the output value Z of the measuring system in accordance with the linearization method being implemented.

Z_K is the output value of the measuring system after the correction.

Fig. 2 shows a generalized scheme of the functional-structural implementation model methods of linearizing the nonlinear characteristics of the measuring system by introducing numerical corrections into the measurement results.

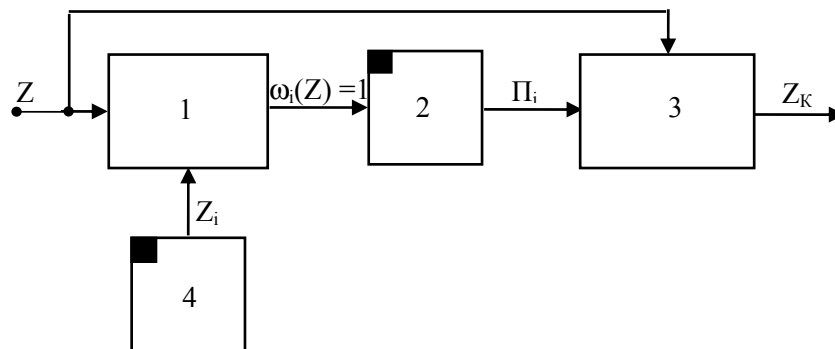

Fig. 2. Functional-structural implementation model methods of linearization by introducing numerical corrections

1 – Determining the number (i) of the section of the fragmentation characteristic to the limits of which corresponds to the output value of the measuring system, $Z \in [Z_{i-1}; Z_i]$

2 – Storing corrections (Pi) for introduction into the output value of the measuring system within the ith section.

3 – Carrying out a computational operation between the correction P_i and the output value Z of the measuring system in accordance with the linearization method being implemented.

4 – Storing Z_i values corresponding to the boundaries of the fragmenting the non-linear characteristic of the measuring system transformation into sections.

In order to determine the section number, the current value of the measured quantity is compared in turn to the values of the boundaries stored in the microprocessor's memory. When the condition $Z_{i-1} \leq Z \leq Z_i$ is carried out, the logic function becomes equal to unit, $\omega_i(Z)=1$, which indicates the determination of the area number within the range of the value of the measured quantity. After that, the correction P_i corresponding to this section number of the fragmentation is selected from the memory of the microprocessor. By implementing a computational operation between the correction P_i and the output value Z of the measuring system, in accordance with the linearization method being implemented, the adjusted value Z_K is obtained.

В.А. Аббасов

Алгоритмічні способи лінеаризації характеристики перетворення вимірювальних систем

Азербайджанський Государственный Університет Нафти і Промисловості, пр. Азадлиг, 20, Баку, Азербайджан, AZ- 1010

E-mail: vaqif_abbas@mail.ru

Існують технологічні, конструктивні, схемні, структурні, структурно-алгоритмічні та алгоритмічні методи лінеаризації характеристики перетворення засобів вимірювання [1,2,3,4]. Тільки алгоритмічні способи, засновані на обробку вимірювальної інформації, отриманої від вимірювальної системи (ВС), можуть відповідати пропонованим до способів лінеаризації вимогам, як виняток необхідності використання високоточних зразкових мір і відключення вимірюваної величини від входу ВС і втручання в структуру і принципи їх побудови. Відомі алгоритмічні способи лінеаризації вимагають відтворення нелінійної функції, зворотної функції перетворення ВС або нелінійної функції коректує поправки. У статті розглядаються запропоновані способи лінеаризації, що виключають необхідність у відтворенні нелінійних функцій, що відрізняються применимостью до широкого класу нелінійних характеристик без обмеження на ступінь їх нелінійності, які засновані на введенні в результат вимірювання аналітично визначаються і запам'ятовуються в пам'яті мікропроцесора численних

3. Conclusion

The proposed algorithmic methods of linearization by introducing numerical corrections into the measurement results exclude the need for reproducing nonlinear functions and have no limitation on their form and the degree of their nonlinearity, and also eliminates the operations for subtracting the initial values of the output quantity of the MS.

The application of these methods also allows solving the problem of distributing computational resources between the functional blocks of information-measuring and control systems.

References

- [1] Aliev T.M., Seidel L.R. Automatic correction of errors in digital measuring instruments. –
- [2] Moscow: Energia, 1975.-216с.
- [3] Bromberg E.M., Kulikovskiy K.L. Test methods for increasing the accuracy of measurements.
a. Moscow: Energia, 1978.-176 p.
- [4] Tokarev O.D., Leonets V.A., Pavlyuk S.O., Chaus L.M.. Algorithmic way of linearization of
- [5] characteristics of sensors. - Journal: Sensors and systems, publishing house: Sensidat-Plus
- [6] (Moscow) p. 6 - 9. ISSN: 1992 - 7185.
- [7] Tuz Yu.M. Structural methods for increasing the accuracy of measuring devices. - Kiev:
- [8] Visha school, 1976. -256 p.

коригувальних поправок для кожної ділянки розбиття характеристики перетворення ВС. Залежно від виконуваних обчислювальних операцій для введення в результат вимірювання поправок ці способи названі «адитивний» (підсумовування або віднімання), «мультиплікативний» (множення), «адитивно-мультиплікативний» (підсумовування і множення в межах однієї ділянки), «комбінований» (в деяких ділянках множення, а в інших - підсумовування)

Ключові слова: адитивний; адитивно-мультиплікативний; вимірювальна система; засоби вимірювання; лінеаризація; функція перетворення; коригувальна поправка; мультиплікативний; комбінований

Аббасов В. А.

Алгоритмические способы линейаризации характеристики преобразования измерительных систем

Азербайджанский Государственный Университет Нефти и Промышленности, пр. Азадлыг, 20, Баку, Азербайджан, AZ- 1010

E-mail: vaqif_abbas@mail.ru

Существуют технологические, конструктивные, схемные, структурные, структурно-алгоритмические и алгоритмические методы линейаризации характеристики преобразования средств измерения [1,2,3,4]. Только алгоритмические способы, основанные на обработке измерительной информации, полученной от измерительной системы (ИС), могут отвечать предъявляемым к способам линейаризации требованиям, как исключение необходимости использования высокоточных образцовых мер и отключения измеряемой величины от входа ИС и вмешательства в структуру и принципы их построения. Известные алгоритмические способы линейаризации требуют воспроизведения нелинейной функции, обратной функции преобразования ИС или нелинейной функции корректирующей поправки. В статье рассматриваются предложенные способы линейаризации, исключающие необходимость в воспроизведении нелинейных функций, отличающиеся применимостью к широкому классу нелинейных характеристик без ограничения на степень их нелинейности, которые основаны на введении в результат измерения аналитически определяемых и запоминаемых в памяти микропроцессора численных корректирующих поправок для каждого участка разбиения характеристики преобразования ИС. В зависимости от выполняемых вычислительных операций для введения в результат измерения поправок эти способы названы «аддитивный» (суммирование или вычитание), «мультипликативный» (умножение), «аддитивно-мультипликативный» (суммирование и умножение в пределах одного участка), «комбинированный» (в некоторых участках умножение, а в других – суммирование).

Ключевые слова: аддитивный; аддитивно-мультипликативный; измерительная система; комбинированный; корректирующая поправка; линейаризация; мультипликативный; средства измерения; функция преобразования

Abbasov Vagif Abbas oglu. Candidate of technical sciences. Assistant Professor.

Department of Instrument-Making Engineering, Azerbaijan State Oil and Industry University.

Education: Azerbaijan Oil and Chemistry Institute, Baku, Azerbaijan (1968).

Research area: Information-measuring systems.

Publications: 110.

E-mail address: vaqif_abbas@mail.ru