

Foodways architecture: storing, processing and dining structures at the Late Neolithic Vinča culture site at Stubline

Miloš Spasić, Saša Živanović

Department of Archaeology, Belgrade City Museum, Belgrade, RS
milos.spasic@mgb.org.rs

ABSTRACT – *The paper presents an analysis of storing, processing and dining structures from the Vinča culture site at Stubline. Numerous clay structures found in houses were associated with everyday activities related to food. We argue that these structures were not only important in subsistence strategies, but were also profound symbolic agents involved in complex symbolic practices related to the conceptualisation of social spaces in Vinča culture houses.*

IZVLEČEK – *V članku predstavljamo analize struktur, povezanih s shranjevanjem, pripravo in uživanjem hrane v kulturi Vinča na najdišču Stubline. V hišah so bile najdene strukture, ki jih lahko povežemo s hrano in vsakodnevnimi aktivnostmi. Trdimo, da so strukture enako pomembne v subsistenčnih strategijah in kompleksnem simbolnem delovanju pri oblikovanju socialnega prostora v hišah kulture Vinča.*

KEY WORDS – *storing; processing and dining structures; Stubline; Late Neolithic; Vinča culture*

Late Neolithic Vinča culture site at Stubline

Stubline is a Late Neolithic Vinča culture settlement near Serbia's capital Belgrade, built on an elevated slope around 4850/4800 BC. The plateau, 16ha in area, was surrounded by two watercourses. The Stubline site lies in a small micro-region, with several contemporary Late Neolithic Vinča culture settlements in the immediate vicinity. The first excavations at the site were carried out for one month in the late 1960s (*c.f. Todorović 1967*). Systematic excavations were renewed in 2006, and have continued since then on behalf of the Belgrade City Museum (*c.f. Crnobrnja et al. 2009; Crnobrnja 2012*).

Based on the current excavation and prospection data, the Neolithic settlement is exceptionally well preserved, with more than 200 above-ground houses arranged in rows (Fig. 1), with linear communications, open spaces, and circular ditches surrounding the settlement (*Crnobrnja et al. 2009; Spasić 2012a*). As in many other Neolithic villages in the Central Balkans, the ground plan of the settlement at Stubline clearly illustrates settlement growth dynamics.

We do not know which house was the first to be built in Stubline or who its first inhabitants were, but over time, the settlement extended, and two ditches were dug out at the far western part, either as a symbolic division of space, or in order to protect the inhabitants and their possessions (*c.f. Spasić 2012a.16*). As time passed, the community grew, and as a result, the two ditches were filled in order to provide the additional space needed to build houses. The houses were again erected in rows, in the same direction as the earlier ones. This layout of new buildings enabled the persistence of former communications. New Stubline shows continuity with earlier organisational ideas, which, on a broader scale, reflects that the settlement narrative was an enduring, long-term process, rather than an event or point in history, a true case of *longue durée*.

Three above-ground houses were discovered during the 2008, 2010 and 2014 excavations (*Crnobrnja et al. 2009; Crnobrnja 2012*). The excavated houses were rectangular, with exceptionally well-preserved

house inventories that offered unique insights into Neolithic housing. The house from the 2008 field season is rectangular in form, with no discernible subdivision into rooms. The household inventory consists of two ovens, one quern, and one clay structure for cereal storage, dozens of ceramic vessels, 43 anthropomorphic figurines and 11 miniature tool models (Fig. 2). Among other finds, one portable clay *bucranium* was found in the central part of the house. The second house was also rectangular, again with no discernible subdivision of interior space (Fig. 2). The house had a massive clay floor and numerous well-preserved structures and finds (two ovens, one clay table, one quern, a large number of storage vessels, etc.). Two *bucrania* associated with a large oven in the north-eastern part of the house were found facing the floor. A third *bucranium* made entirely of clay was found in the mass of collapsed wall fragments in the heavily damaged southern part of the house (c.f. Spasić 2012b.300–301, Fig. 10–11). The latest investigated house was also rectangular, and had two discernible phases in its history. During the earlier phase, the house had a single room, and one oven,

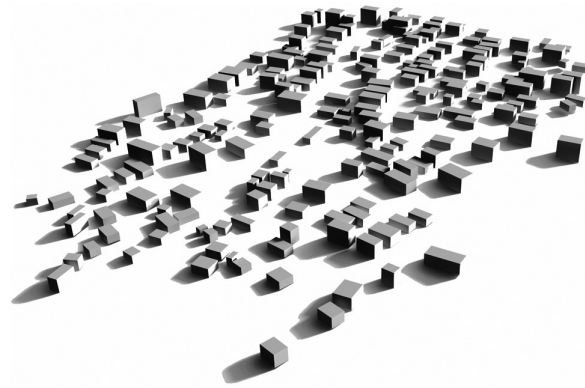

Fig. 1. 3D reconstruction of Vinča culture settlement in Stubline.

while in the later phase the interior was reorganised by raising a partition wall, and changing the position of the oven. Besides the confirmation that numerous activities were carried out in Vinča culture houses, as well as clear evidence that the houses were both sacred and everyday places, the houses in question revealed the way in which their inhabitants conceived their natural environment, community, and foreigners. Up to a certain point, their houses reflected themselves.

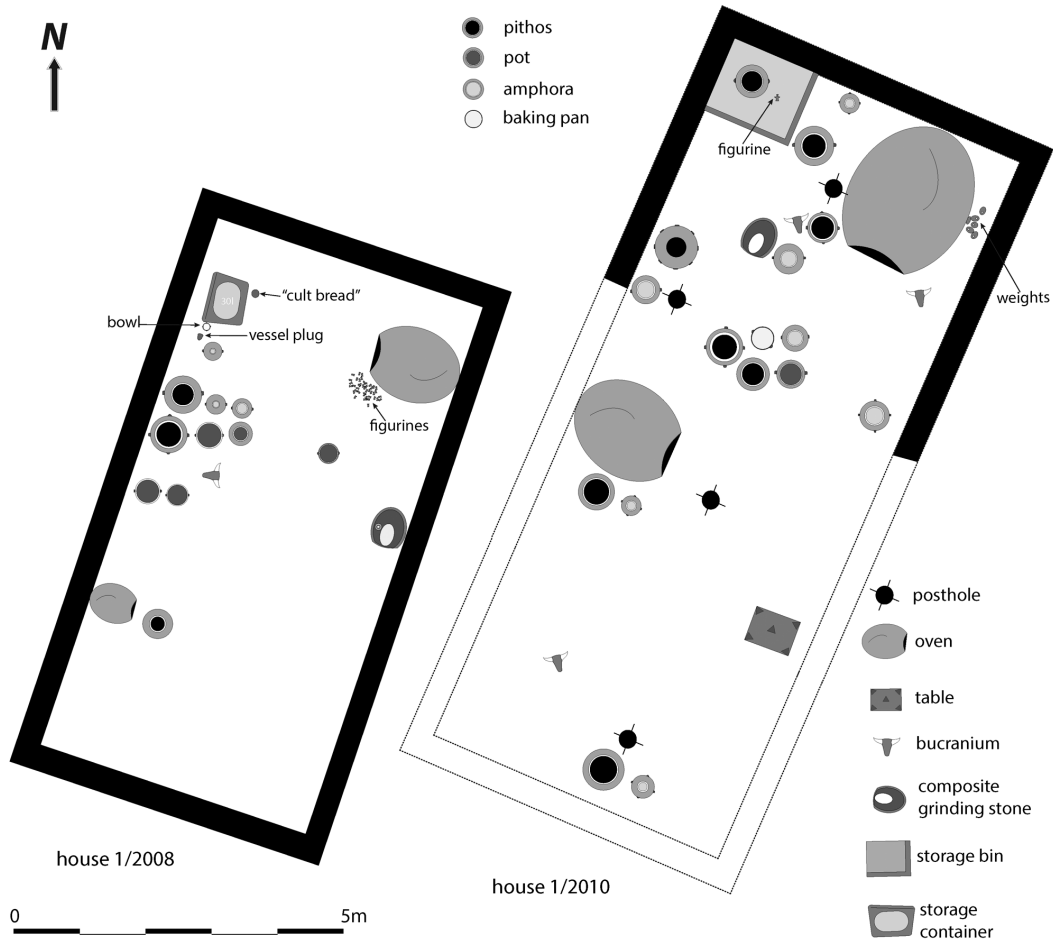

Fig. 2. Layout of storing, processing, and dining structures in Vinča culture houses at Stubline.

Storing, processing, and dining structures at Stubline

Architectural structures associated with storing and processing food, as well as for dining were found in all the excavated Neolithic houses at Stubline (c.f. *Crnobrnja et al. 2009; Crnobrnja 2012*). Common to all the excavated structures is that they were made of unfired clay and that they were more or less fixed constructions not intended to be moved around the house. Two architectural storage facilities, two composite clay quern structures, and three fragmented clay tables were found, besides more ordinary objects used for storing, processing, and dining (such as clay vessels, grindstones and others). Such clay structures have been identified also at several other Vinča settlements (*Bogdanović 1988; Todorović, Cermanović 1961; Todorović 1981; Tasić et al. 2007; Tripković 2007; 2011*). Since these structures (especially storage and processing ones) were not intended to be moved, a certain part of the house and floor area must have been occupied for longer periods. Thus, we see great significance in these structures, both in relation to the house inventory and in analyses of house histories.

The inventory of houses 1/2008 and 1/2010 included two clay structures/querns for food processing (i.e. grinding). Both querns are composite shell-shaped structures consisting of a shallow clay receptacle with an upright clay base for a grindstone. The quern in house 1/2008 (Fig. 3) was found near the eastern wall, around 3m from the northeastern corner of the house (*Crnobrnja et al. 2009.13, 17, Fig. 5/4*). The quern in house 1/2010 (Fig. 4) was also found in the northern part of the house, approx. 5m to the east of large oven 1 (*Crnobrnja 2012.48, 55, Fig. 3/8*). Both structures have an ovoid shell-shaped receptacle, 15cm deep, with an opening at the lower end. The conical walls of the receptacle are 5–7cm thick with a diameter of approx. 50–55cm. Oval 30 x 20–25cm upright-modelled clay platforms are 12–13cm high, and have a shallow recession for positioning an oval grind. When worn out, the grindstone inserted in the bedding of the platform was replaced. The basic form of the querns was built using traditional coil-building technique, after which additional layers and coatings of clay were applied. The clay quern in house 1/2008 was probably built directly over the house floor and was fixed, while the quern in house 1/2010 had a solid flat base and could have been repositioned in different parts of

the house. The fixed structure of the first quern has the great advantage of compactness and stability of construction, while the benefit from the portability of the second quern should not be neglected. The portable clay structure of the quern from house 1/2010 could have been further stabilised by fixing it to the floor through two holes in its base.¹ Both structures were heavily secondarily burnt in the fire that ended the lives of the houses.

A question remains as to whether the querns were built of unfired clay. When it comes to the quern from house 1/2008, it could be concluded with great certainty that the structure was not fired, while the one from house 1/2010 was probably fired in order to make the quern portable.

Two clay structures for food storage were discovered in houses 1/2008 and 1/2010, besides numerous large-sized vessels of *pithoi* and amphora type that were intended for the same or a similar purpose. A trapezoidal storage structure, 80 x 65cm, in the form of a shallow oval receptacle was identified in the north-western part of house 1/2008 opposite oven 1 (Fig. 5; c.f. *Crnobrnja et al. 2009.16, 17, Fig. 5/3, Fig. 12*). The height of the receptacle walls varies

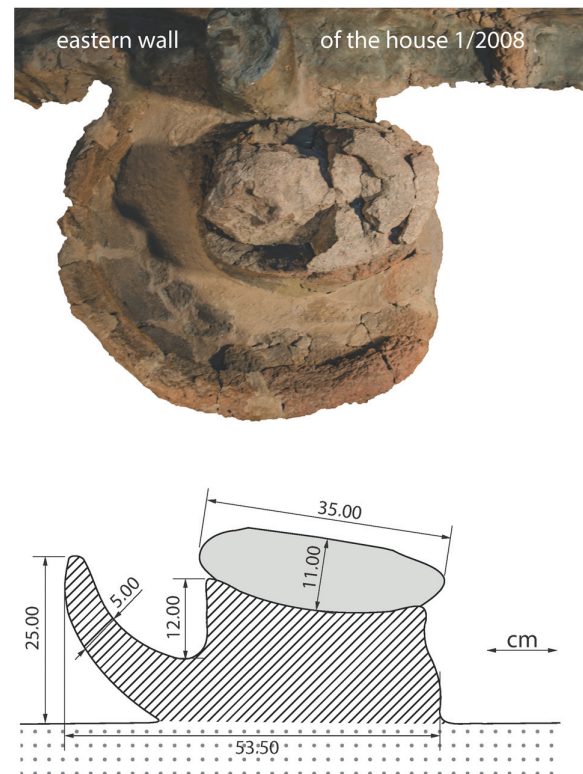

Fig. 3. Composite grinding structure from 1/2008 house in Stubline.

¹ Small holes for attaching the quern structure were also observed near the floor area where the quern was found.

from 8–12cm, while its rear is 35cm high. The full capacity of the structure is approx. 30 litres. This storage container was constructed directly over the house floor, and built by erecting 5–15cm thick walls made of unburnt clay. Several flat curved objects of fired clay, a vessel plug (Fig. 6) with textile impressions, and another shallow bowl with a false spout, another conical bowl and a storage vessel of amphora type were found around the container.

The second clay storage structure was discovered in house 1/2010 (*Crnobrnja 2012.48, 54, Fig. 3/6*). The structure in question is a shallow rectangular storage bin, 140 x 120cm (Fig. 2), unearthed in the northwestern part of the house opposite the large oven. The bin was formed as an enclosed space, the northern and western walls of which were actually house walls, while the remaining two walls were built on the house floor. The walls of the storage bin were preserved to a height of approx. 12cm. It should be noted that the floor of the bin had a sub-structure comprising three layers of pottery sherds and clay coatings that resembled the floor-building technique for thermal structures (*Crnobrnja 2012.48, 54*). A large amount of pottery fragments, most of which were from a single *pithos*, and one anthropomorphic figurine were found inside the storage bin (*Crnobrnja 2012.54, Fig. 14*).

Three fragmented clay-dining structures in form of a low table were discovered at Stubline. The table from house 1/2010 was almost completely preserved (*Crnobrnja 2012.54, 55, Fig. 12*). It was positioned in the southern part of the house near its eastern wall (Fig. 7). A rectangular table slab, 70 x 50cm, was modelled on five short triangular legs, one at each corner of the table, and one in the centre (Fig. 7). The table was approx. 20cm high. A typical Vinča biconical bowl was found placed on the table. The remaining two heavily fragmented tables were found in two refuse pits during the 2014 campaign. The infill of these pits consisted solely of densely packed daub fragments (*i.e.* wall and floor fragments), charcoal, and ash. Only one leg and part of a clay table slab were preserved from both table structures. Their morphology is similar to the table from house 1/2010; even the dimensions roughly correspond (Figs. 8, 9). One of these tables has a rather different slab: it is rectangular, with a low oval wall around it. Thus, the surface of the table resembles a shallow oval receptacle (Fig. 9).

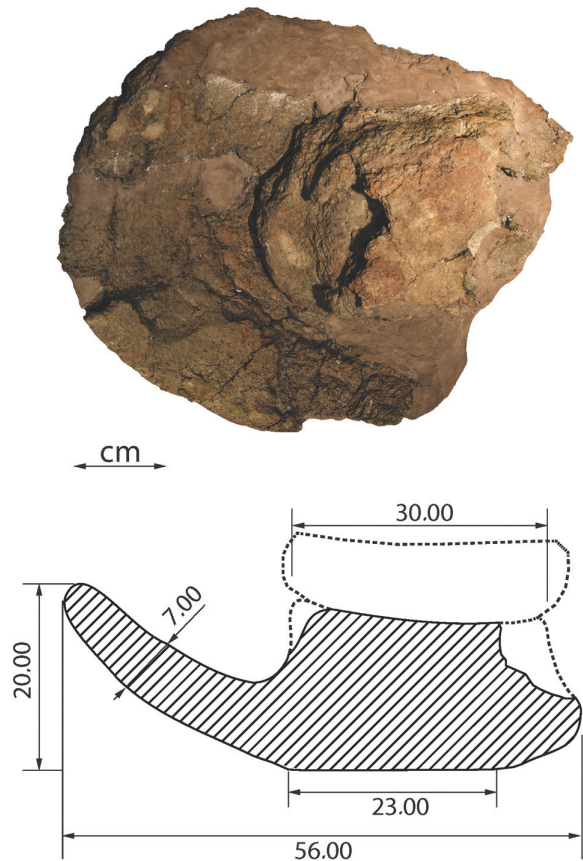

Fig. 4. Composite grinding structure from 1/2010 house in Stubline.

The construction technique of table structures at Stubline could be nicely observed on one of the finds from the 2014 campaign. The cross-section of the fragmented table leg clearly shows that whole structure was built in steps. Rough clay core resembling the final structure was first formed, followed

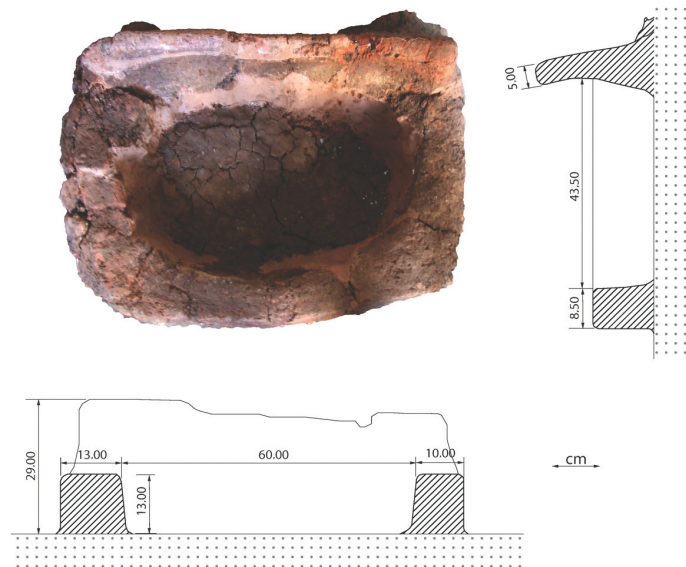

Fig. 5. Storage container from 1/2008 house in Stubline.

by successive applications of clay coating, 1.5–2 cm thick, on the core (Fig. 8).

Discussion

The last decade of scientific research into the household and spatial organisation of Vinča settlements has seen an immense advance in the comprehension of the everyday lives of Late Neolithic communities in the Central Balkans. Boban Tripković made an initial breakthrough in this field, analysing various aspects of household activities in his seminal books on the household and settlement organisation of Vinča settlements in the Central Balkans (*Tripković 2007; 2013*). Regarding the question of cereal storage and related household activities and facilities, Boban Tripković rightly perceives it as one of the most important aspects of household/settlement organisation (*Tripković 2007.27–31*).² Based on the current data, various types of clay structure for storing, processing and dining have been identified at numerous Vinča settlements (Figs. 10, 11), such as at Divostin (*Bogdanović 1988*), Vinča (*Tasić et al. 2007*), Banjica (*Todorović 1981; Tripković 2007*), Opovo (*Tringam et al. 1985; 1992*), Beletinci (*Bruker 1962; Chapman 1981*), Pločnik (*Radivojević et al. 2013; Radivojević, Kuzmanović-Cvetković 2014*), Čučuge (*Andelković-Despotović, Redžić 1992*), Griovac (*Bogdanović 2008*), Gomolava (*Jovanović 2011*), Jakovo (*Jovanović, Glišić 1961*), and Uivar (*Schier 2006*). Until very recently, such unfired clay structures have often been neglected in studies of Neolithic household organisation because of the poor state of preservation.

New and more meticulous excavation methodologies have brought to the light several such structures, which resulted in a renewed interest in the topic, as well as a reappraisal of old finds. All of the described storing, processing and dining structures are of great importance for the study of household organisation. Besides their functional value, their main characteristic is that they are more or less fixed structures occupying a certain area of the house floor, thus enabling a profound analysis of various household activities that transpired in Vinča houses.

The function of composite clay querns as structures for processing cereal is now indisputably confirmed, after more than three decades of uncertainties regarding the definition of their purpose. Since the

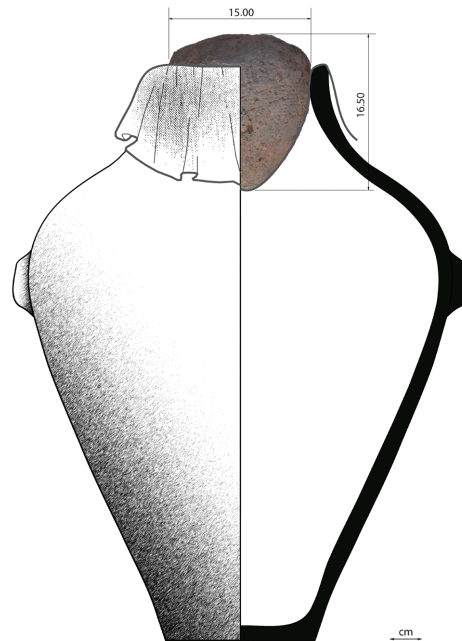

Fig. 6. Reconstruction of vessel plug usage.

discovery of one in a Vinča house at the Banjica site (Fig. 12), misconceptions about its usage brought to light anecdotal interpretations that defined them as equipment for processing dairy products (*Todorović 1981.16*). After the discoveries of composite clay querns at the sites at Vinča (*Tasić et al. 2007*), and Stubline (*Crnobrnja et al. 2009; Crnobrnja 2012*) their function as structures for processing cereal is unquestionable. Further confirmation of this interpretation is assured through the discovery of several grains of *Triticum dicocum* near a composite clay quern at Vinča (*Tasić et al. 2007.214, 219*,

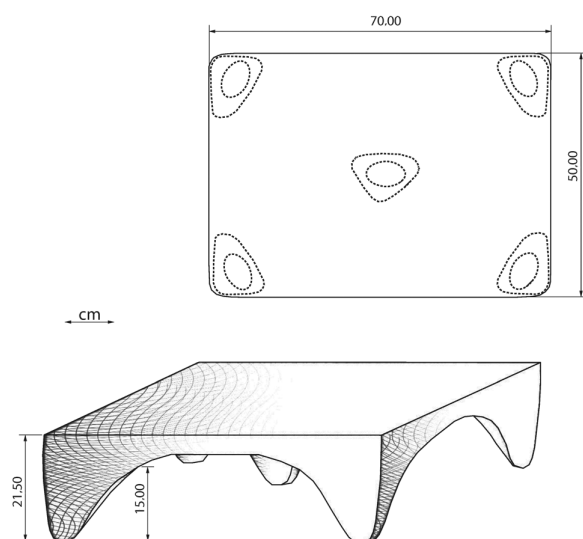

Fig. 7. Clay table from 1/2010 house in Stubline.

² Another seminal book devoted solely to the history of cereal storage in Balkan prehistory appeared almost simultaneously, providing a solid basis for understanding the topic (*c.f. Jević 2011*).

T. II/2). On the other hand, spatial distribution also clearly indicates that these structures were mainly associated with thermal structures, clay vessels and other structures for storing cereals (c.f. *Tripković 2013.106, 159*). Similar composite clay querns were later identified in the corpus from older excavations (Fig. 11), such as from house 2/79 at Banjica (*Todo- rović 1981*), house 13 at Divostin (*Bogdanović 1988. 51, 79, Figs. 5, 26 B*), and houses IV/1956 and 3/ 1980 at Gomolava (*Jovanović 2011.25–26*). Outside the zone of Vinča culture, composite clay querns for processing cereal were also identified at sites at Liga in Northern Bulgaria (*Merkyte 2005.16*).

Two different types of clay storage structures were identified in the northern zones of houses 1/2008 and 1/2010 at Stubline (Figs. 2, 5). The storage bin from house 1/2010 (Fig. 2) is actually an enclosed part of the house that was formed by separating the northwestern corner of the house from the rest of the floor surface with small partition walls. On the other hand, the storage container from house 1/2008 is an autonomous structure with a well-defined receptacle (Fig. 5). Storage bins are recorded at numerous Vinča culture houses: in house 1/06 at Vinča (*Tasić et al. 2007*), in house 2/79 at Banjica (*Todo- rović 1981.14/D; Tripković 2007.89–90*), in house 2 in Opovo (*Tringam et al. 1985.431; 1992.356*), in house 1 at Beletinci (*Brukner 1962.90; Chapman 1981*), in houses 13, 14 and 17 in Divostin (*Bogda- nović 1988*), and in one of the Vinča houses discovered at Uivar in Romania (*Schier 2006.Fig. 5*). The enclosed space in house 4/1980 at Gomolava could most probably also be defined as a storage bin (*Jovanović 2011.27–28*). On the other hand, the type of storage structures discovered in house 1/2008 at Stubline, marked here as a storage container, have so far been identified in only few Vinča houses (Fig. 11). Such and similar clay containers were found in house 21 at Grivac (*Bogdanović 2008.170, 189, Fig. 8.58*), in house 1 at Jakovo (*Jovanović, Glišić 1961. 131, 135*), and in house 15 at Divostin (*Bogdano- vić 1988.61*). The clay structure from the house in Pločnik, interpreted as some sort of thermal structure, could also be identified as a storage container (*Radivojević et al. 2013.1032–1033; Radivojević, Kuzmanović-Cvetković 2014.19*).³ Structures very similar to our storage containers were also discovered in house 13 at Divostin (*Bogdanović 1988.53*), and at the Čučuge site (*Anđelković-Despotović, Red- žić 1992.94*). The finds from house 13 in Divostin

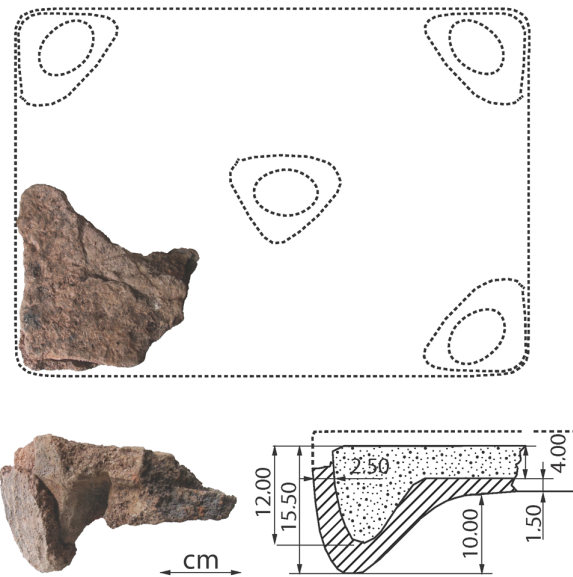

Fig. 8. Fragmented, secondary deposited clay table from a garbage pit discovered during 2014 excavations in Stubline.

and the one from Čučuge are clay containers modeled on clay legs, and are the only portable structures of this type discovered so far.

Clay structures analogous to those presented here and associated material culture assemblages from

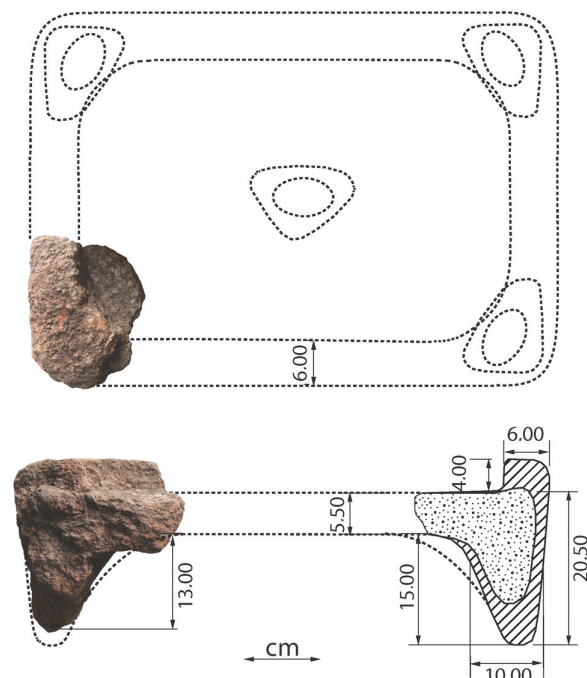

Fig. 9. Fragmented, secondary deposited clay table with shallow recipient from a garbage pit discovered during 2014 excavations in Stubline.

³ The authors were provided with field documentation from Pločnik excavations thanks to the kindness of Duško Šljivar, the director of the excavations, and museum counselor.

other Vinča-culture houses suggest that their association with food storage is indisputable (Tripković 2013: 79). An impressive contribution to the analysis of storing inside Neolithic houses was made through the discovery of almost all the known types of storage structure, as well as 225kg of burnt grain in the Neolithic house at Slatina in Bulgaria (Nikolov 1989). Still, these structures were given other interpretations also. The storage bin from the house 2/79 at Banjica was identified as a space for tanning calf skin (Todorović 1981:16), while various storage containers from Macedonian Neolithic houses have been associated with leavening dough (Čausidis 2010:147). Storage containers have also very often been related to cult practices and interpreted as cult altars (c.f. Kitanovski, Simoska, Jovanović 1990:107–112; Mitkoski 2005: 35, 38; Jovanović, Glišić 1961:131–134). Any use of the clay bins and containers that infers a use of water and some kind of liquid should probably be ruled out, since all of the described structures were made from unfired clay, which is soluble and porous in contact with liquids. The considerable formal and technical/structural variation in both storage bins and storage containers could also point to the different types of food stored in them. It is also intriguing to note that the storage container from house 1/2008 in Stubline had a total capacity of not more than 30 litres, and that in the same house, numerous much bigger large-scale vessels for storing both liquids and cereals were found (Fig. 2). The same could be said for house 1/2010, whose inventory consisted of several vessels with a capacity of more than 100 litres (Fig. 2). One can only speculate why, alongside storage vessels that served the basic need for in-house storage well, Neolithic communities of the Central Balkans built storage bins and containers that permanently occupied a substantial area of house floors. As a way to understand this matter, we infer two possible explanations. It could be assumed that both storage bins and containers were not as permanent as it has been presumed. They could easily be torn down and rebuilt

seasonally when in-house storage demanded more capacity than vessels.⁴ Their function could also have changed from time to time. On the other hand, perhaps clay bins and clay containers met some storage conditions that other vessels could not.

Besides Stubline, the only clay dining structures in the form of modern-day tables in Vinča culture houses have been found at Divostin (Fig. 11). Total of eight tables was found at Divostin, four of them were before recovered from house 13. Seven were oval, while the eighth was rectangular. Their state of preservation varies. The largest one was found in house 18, and had a table slab around 60 x 40cm (Bogdanović 1988:68). It is important to mention that all the Divostin tables were found in houses which had been in use for a very long time (i.e. house 13–15), and also that they were found in rooms which were additionally built in later phases of houses. As at Stubline, clay bowls and other objects (i.e. weights, small

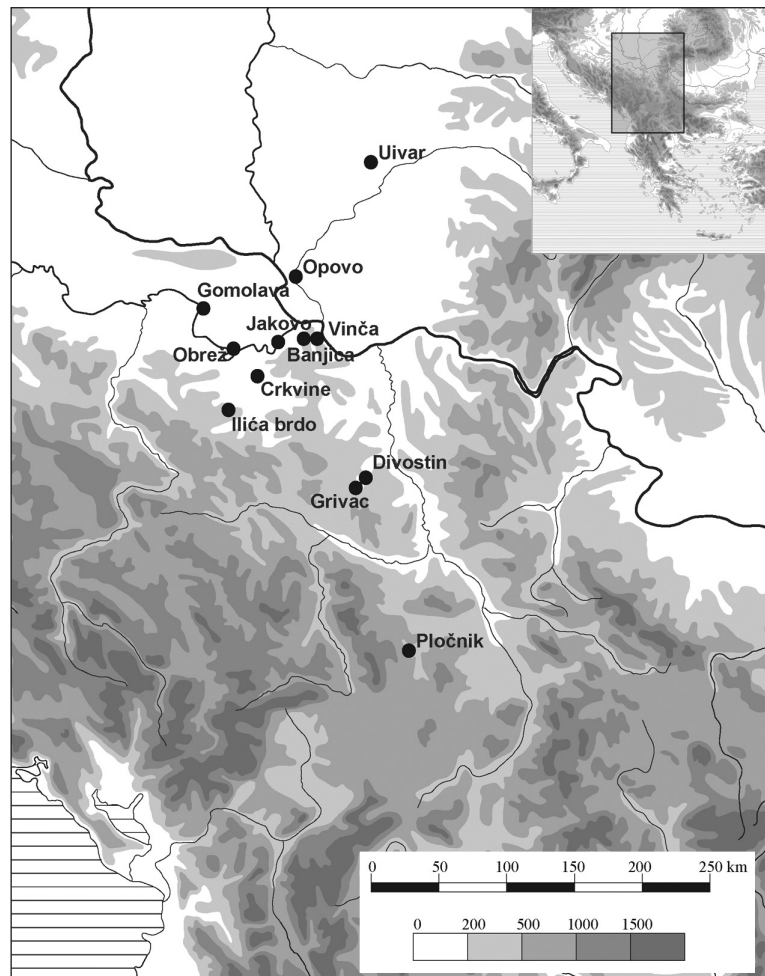

Fig. 10. Vinča-culture settlements mentioned in text (base map courtesy of M. Milinković).

⁴ House histories in Vinča culture were very dynamic and frequently marked by numerous changes in house organisation.

clay altars, miniature vessels) were found on the top of some of the tables (Bogdanović 1988:53, 63).

There is no observable pattern in the spatial distribution of storing, processing and dining structures in different houses across the whole Vinča culture *oecumene*. On the other hand, there are some noticeable patterns at intra-settlement levels. The main activity areas associated with food storage and processing in Stubline are concentrated in the northern parts of the excavated houses (Fig. 2). Thermal structures and numerous vessels for grain and liquid storage were associated with northern areas of the houses, as well as storage and processing structures. A similar tendency towards more intensive use of northern house areas is also observed at Divostin, while

at Banjica, Gomolava, and Jakovo, this density of various activities is noticeable in the central rooms/parts of the houses (Fig. 11; *c.f.* Tripković 2013:126).

To store and process grains or to retain and understand ways

Based on the various household data, we argue that storing, processing and dining structures were not only important in subsistence strategies, but that they were also profound symbolic agents included in complex symbolic praxes related to the conceptualisation of social spaces in Vinča culture houses. We infer that there are two possible strategies in identifying the role of clay structures in conceptualising social spaces and symbolic reproduction in Vin-

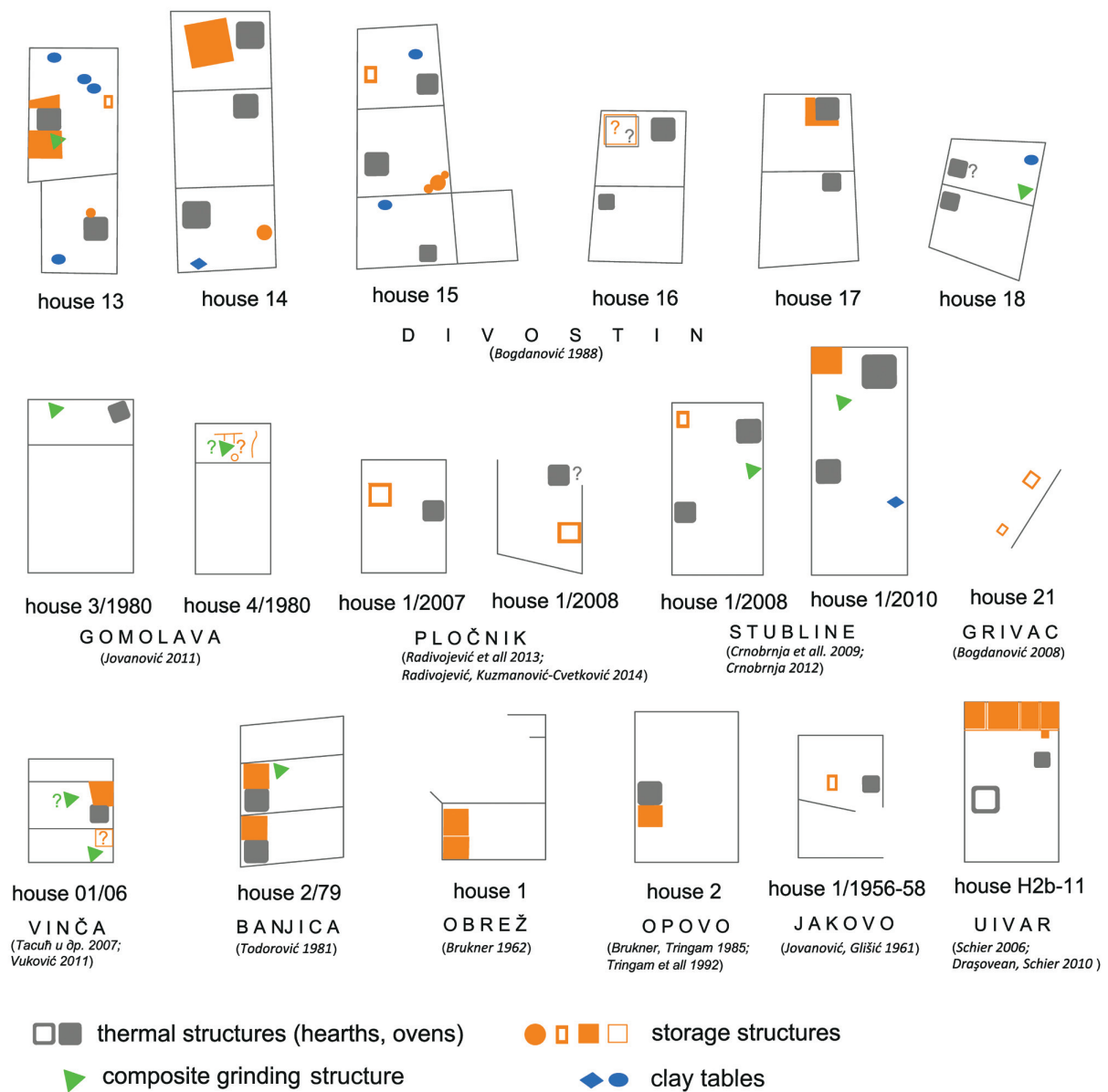

Fig. 11. Schematic layout of storing, processing, and dining structures in Vinča culture houses.

ča houses. The first one includes already discussed role of the structures themselves, while the other employs analyses of their associations with other important material agents. As shown above, all of the structures were clearly connected to food management, especially to grains. However, several of these structures have clear symbolic potency through animal symbolism. The storage container from the site at Jakovo, and one of the clay tables from Divostin have horn-like protrusions (c.f. Jovanović, Glišić 1961.131–134; Bogdanović 1988.53). The fact that the storage container from Jakovo was decorated and had horn-like protrusions led to misconceptions in interpretation, so until very recently the object was thought to be a cult altar. There are numerous other associations of storing, processing, and dining structures with material culture imbued with animal symbolism. The storing and processing structures from the house 1/2010 at Stubline were found near a large oven and two clay *bucrania* (Fig. 2; c.f. Spasić 2012b.300–301, Figs. 10–11). The storage container at Jakovo was also associated with a *bucranium* placed on a wooden pole in front of it, while one hybrid human/animal figurine and so-called amulet with two hybrid *protomae* were found immediately beside it (c.f. Jovanović, Glišić 1961; Spasić 2012b.299–300, Figs. 6–7). In one of the storage bins from house 2/79 at Banjica, an almost complete bull skull with horns was found (Fig. 13; c.f. Todorović 1981). On the other hand, there are also clear associations of our structures with human imagery. A complete anthropomorphic figurine was found deposited in the storage bin in house 1/2010 at Stubline (Fig. 2), while a set of 43 anthropomorphic figurines associated with an oven were found in the vicinity of the composite clay quern in house 1/2008 at Stubline (Fig. 2; Crnobrnja 2011; Spasić 2014). A bowl with eight highly stylised *protomae* and small three-footed vessel were found near the composite clay quern in the house 1/2010 at Stubline (c.f. Crnobrnja 2012.57, Fig. 14; Spasić, Crnobrnja 2014).

The fact that some of the storing, processing and dining structures had clear symbolic value, and that most of them were associated with other objects with great symbolic potency should be examined on a larger scale. We maintain that these structures formed part of larger symbolic assemblages associated with Vinča household narratives. Various sym-



Fig. 12. Composite grinding structure from 2/79 house in Banjica.



Fig. 13. Storage bin from 2/79 house in Banjica.

bolic agents were present inside these houses, and were closely associated together. As already described, all of the clay structures concerned were used at some stage in processes related to storing and processing grain. Grain had powerful symbolic value, which is seen on a far lesser scale in the Vinča material culture.⁵ On the other hand, most of the discussed structures were closely related to animal symbolism (i.e. *bucrania*, horn-like protrusions, amulets, figurines). Human imagery was also present together with animal imagery, the combination of which was somehow connected with dining structures and structures used for storing and processing grain. Thus, Vinča household activities incorporated all the major symbolic aspects of Neolithic life. We argue that these houses were powerful symbolic are-

⁵ Several dozen so-called cult breads from Vinča culture could be indirectly associated with grain symbolism (c.f. Petrović et al. 2009. 162–163). Clear grain symbolism exhibited in clay grain models is present in the preceding Middle Neolithic Starčevo culture (c.f. Nikolić, Zečević 2001.4, 8, 21; Greenfield, Jongsma 2014.8, 10, Figs. 9–10).

nas, where structures for storage or processing grain were connected with potent animal and human symbolism: a genuine example of Hodder's oppositional structuring (male: female; wild: domesticated; plants: animals).⁶

Clay storing, processing, and dining structures are also of considerable importance for understanding Vinča culture household narratives. Several contextual examples convince us that these structures were part of important events in household histories. As described earlier, storage bins, containers and clay tables were frequently erected or placed in newly built adjoining parts of the houses (*i.e.* Divostin). Whether the reason for the rebuilding and the increase in the size of Vinča culture houses was because of physical or material expansion, or symbolic, social or physical reproduction, the structures used for dining, storing and processing clearly denote these events in house histories. Several of the last chapters of Vinča culture house histories were marked by storage and processing structures also. Three sets of bull heads with horns on the floor of house 2/79 at Banjica could probably be interpreted as house closure deposits placed there when the house was abandoned. One of the three bull heads with horns was left in the storage bin (Fig.13; *c.f.* Spasić 2012b.299). We argue that a similar example of house closure depositions can probably be observed in house 1/2010 at Stubline, and that storing and processing structures were also included in it. A composite clay quern structure for processing grain was found in an inverted position, facing the floor. Several large inverted grindstones were found nearby. While the position of the later ones could be interpreted because of house destruction or post-depositional processes, or the position of composite quern clearly indicates that it was intentionally positioned in that way. Thus, we see it as clear evidence of house closure deposition during the abandonment of the house. The complete anthropomorphic figurine found in the storage bin in house 1/2010 was probably left there during the same time event.⁷ An almost complete *pithos* and several fragmented serving vessels were also found in the same storage bin. Not all vessels in the storage bin were heavily secondarily burnt, like the majority of structures and

vessels from house 1/2010. Therefore, the deposition of vessels found in the storage bin probably occurred after the abandonment and destruction of the house. The anthropomorphic figurine discovered in grain silo A at Selevac could also have been deposited upon the closure of the house (*Tringham, Stevanović 1990.59–61, Fig. 4.4/a, d.*)

Closing remarks

Clay storing, processing, and dining structures are important elements of Vinča culture houses. The elaboration of their functional characteristics in the future should include an analysis of their use. We observed great morphological, structural and technological variability in all three categories, so the question is whether this variation corresponds with functional variation. Future analysis should seek to discover if there was difference in the use of storage bins and containers that have more solid floors. What are the main advantages of storage inside fixed storage containers of rather small capacity compared to large capacity vessels? Are there differences between the oval and rectangular clay tables? Are there functional differences between clay tables with a flat slab and those with some kind of wall around the slab? So far, we have succeeded in understanding that clay storing, processing, and dining structures were important features of subsistence in houses, but also that they are important elements for understanding Vinča house narratives.

6 *c.f.* Hodder 1990.20–92; 1992.23–27. The concept of binary oppositions has been much debated recently (*c.f.* Thomas 1991.14; Whittle 2003.93; Russell 2012.246–247). Despite some shortcomings and limitations, the concept has enormous interpretative potential.

7 Complete anthropomorphic figurines were occasionally found in Vinča culture houses (*i.e.* Divostin, Stubline, Jakovo, Grivac, Selevac ...); their appearance in the houses has recently been interpreted as possibly representing closing deposits (*c.f.* Porčić 2012. 823–824; Porčić, Blagojević 2014.94).

References

- Andelković-Despotović Z., Redžić M. 1992. Arheološka iskopavanja neolitskog lokaliteta Ilića Brdo u selu Čučuge. *Zbornik Narodnog muzeja Beograd* 14(1): 93–102.
- Bogdanović M. 1988. Architecture and Structural Features at Divostin. In A. McPherron and D. Srejović (eds.), *Divostin and the Neolithic of Central Serbia*. Narodni muzej – University of Pittsburgh. Kragujevac-Pittsburgh: 35–142.
- Brukner B. 1962. Praistorijsko naselje na potezu Beletinci kod Obreža. *Rad vojvodanskih muzeja* 11: 89–122.
- Chapman J. 1981. *The Vinča Culture of Southeast Europe*. British Archaeological Reports IS 117. Archaeopress. Oxford.
- Crnobrnja A. 2011. Arrangement of Vinča culture figurines: a study of social structure and organisation. *Documenta Praehistorica* 38: 131–147.
2012. Investigations of Late Vinča house 1/2010 at Crkvine in Stubline. *Starinar* 62: 45–64.
- Crnobrnja A., Simić Z. and Janković M. 2009. Late Vinča culture settlement at Crkvine in Stubline: household organization and urbanization in the Late Vinča culture period. *Starinar* 59: 9–25.
- Čausidis N. 2010. Mati hleba. Ženski aspekti naćvi, peći i crepulje u slovenskom folkloru u relaciji s praistorijskim tradicijama. In D. Žunić (ed.), *Tradicionalna estetska kultura: Hleb*. Centar za naućna istraŹivanja SANU Univerziteta u Nišu. Niš: 131–167.
- Greenfield H., Jongsma T. 2014. Subsistence and settlement in the Early Neolithic of temperate SE Europe: a view from Blagotin, Serbia. *Archaeologia Bulgarica XVIII(1)*: 1–33.
- Hodder I. 1990. *The Domestication of Europe: Structure and Contingency in Neolithic Societies*. Blackwell. Oxford.
1992. *Theory and practice in archaeology*. Routledge. London and New York.
- Jevtić M. 2011. *Ćuvare Źita u praistoriji: Studija o Źitnim jamama sa Kalakaće kod Beške*. Gradski muzej Vršac. Filozofski fakultet u Beogradu. Vršac-Beograd.
- Jovanović M. 2011. *Masters of Clay and Wheat*. Muzej Vojvodine. Novi Sad.
- Jovanović B., Glišić J. 1961. Eneolitsko naselje na Kormadinu kod Jakova. *Starinar* 11: 113–139.
- Kitanoski B., Simoska D. and Jovanović B. 1990. Der kultplatz auf der fundstatte Vrbjanska Ćuka bei Prilep. In D. Srejović, N. Tasić (eds.), *Vinča and its World*. International Symposium. The Danubian Region from 6000–3000 BC. Serbian Academy of Science and Arts, Centre for Archaeological Research. Faculty of Philosophy. Beograd: 107–112.
- Merkyte I. 2005. Līga, Copper Age Strategies in Bulgaria. *Acta Archaeologica* 76(1): 9–194.
- Mitkoski A. 2005. Vrbjanska Ćuka kaj seloto Slavej, Prilepsko. *Zbornik na Muzejot na Makedonija 2 (arheologija)*: 33–46.
- Nikolić D., Zećević J. 2001. *Blagotin-istraŹivanja 1989–1999*. Filozofski fakultet. Beograd.
- Nikolov V. 1989. Das Frühneolithische Haus von Sofia-Slatina. *Germania* 67(1): 1–49.
- Petrović B., Katić V. and Spasić M. 2009. *Źivot u glini: neolitska umetnost na tlu Beograda – figuralna plastika iz zbirki Muzeja grada Beograda*. Muzej grada Beograda. Beograd.
- Porćić M. 2012. Contextual analysis of fragmentation of the anthropomorphic figurines from the Late Neolithic site of Selevac. *Etnoantropološki problemi* 7(3): 809–827.
- Porćić M., Blagojević T. 2014. Fragmentation, context and spatial distribution of the Late Neolithic figurines from Divostin, Serbia. In C-E. Ursu, S. Źerna (eds.), *Anthropomorphism and symbolic behaviour in the Neolithic and Copper Age communities of South-Eastern Europe*. Editura Karl A. Romstorfer. Suceava: 91–107.
- Radivojević M., Rehren T., Kuzmanović-Cvetković J., Jovanović M. and Northover P. J. 2013. Tainted ores and the rise of tin bronzes in Eurasia, c. 6500 years ago. *Antiquity* 87: 1030–1045.
- Radivojević M., Kuzmanović-Cvetković J. 2014. Copper minerals and archaeometallurgical materials from the Vinča culture sites of Belovode and Ploćnik: overview of the evidence and new data. *Starinar* 64: 7–30.
- Russel N. 2012. *Social Zooarchaeology: Humans and Animals in Prehistory*. Cambridge University Press. Cambridge.
- Schier W. 2006. Neolithic house building and ritual in the late Vinča tell site of Uivar, Romania. In N. Tasić, C. Grozdanov (eds.), *Homage to Milutin Garašanin*. Serbian Academy of Science and Arts. Macedonian Academy of Science and Arts. Belgrade: 325–339.

- Spasić M. 2012a. *Metahousing: Neolithic and modern dwelling in Belgrade*. Belgrade City Museum. Belgrade.
- 2012b. Cattle to settle-bull to rule: On bovine iconography in Vinča culture. *Documenta Praehistorica* 39: 285–309.
2014. A Group Find of Neolithic Figurines of the Vinča Culture from Stubline, Serbia. *Newsletter of the Association for Coroplastic Studies* 12: 5–8.
- Spasić M., Crnobrnja A. 2014. Vinčanske zdele sa protomama. *Starinar* 64: 185–203.
- Tasić N., Đuričić S. and Lazarević B. 2007. Analiza konstrukcije žrvnja iz objekta 01/06 u Vinči. *Glasnik Srpskog arheološkog društva* 23: 211–218.
- Thomas J. 1991. *Understanding the Neolithic*. Routledge. London and New York.
- Todorović J. 1967. Crkvine, Stubline, Obrenovac-naselje vinčanske grupe. *Arheološki pregled* 9: 17–18.
1981. A recently discovered House in the Neolithic Settlement of Banjica in Belgrade. *Archaeologia Iugoslavica* 18: 13–16.
- Todorović J., Germanović-Kuzmanović A. 1961. *Banjica – naselje vinčanske kulture*. Muzej grada Beograda. Beograd.
- Tringham R., Brukner B. and Voytek B. 1985. The Opovo Project: a Study of Socioeconomic Change in the Balkan Neolithic. *Journal of Field Archaeology* 12(4): 425–444.
- Tringham R., Brukner B., Kaiser T., Borojević K., Bukvić L., Šteli P., Russel N., Stevanović M. and Voytek B. 1992. Excavation at Opovo, 1985–1987: Socioeconomic Change in the Balkan Neolithic. *Journal of Field Archaeology* 19(3): 351–386.
- Tringham R., Stevanović M. 1990. Field Research. In R. Tringham, D. Krstić (eds.), *Selevac: A Neolithic Village in Yugoslavia*. The Institute of Archaeology, University of California. Los Angeles: 57–213.
- Tripković B. 2007. *Domaćinstvo i prostor u kasnom neolitu: vinčansko naselje na Banjici*. Srpsko arheološko društvo. Beograd.
2011. Containers and grains: food storage and symbolism in the Central Balkans (Vinča period). *Documenta Praehistorica* 38: 159–172.
2013. *Domaćinstvo i zajednica: Kućne i naseobinske istorije u kasnom neolitu Centralnog Balkana*. Filozofski fakultet. Beograd.
- Whittle A. 2003. *The Archaeology of People: Dimensions of Neolithic life*. Routledge. London and New York.