

PAPER • OPEN ACCESS

## Flexural fluctuations of the rotors of knife refiners

To cite this article: S Vikharev *et al* 2020 *IOP Conf. Ser.: Mater. Sci. Eng.* **734** 012040

View the [article online](#) for updates and enhancements.

# Flexural fluctuations of the rotors of knife refiners

**S Vikharev, A Sannikov and M Zinatov**

Faculty of technical mechanics and the equipment of pulp and paper manufactures,  
Ural State Forest Engineering University, Siberian tract, 37, Ekaterinburg, 620100,  
Russia

E-mail: cbp200558@mail.ru

**Abstract.** The subject of the study is the flexural fluctuations of the rotors of knife refiners. The dynamic and mathematical models of rotors of disk mills are developed. As a result of research, a method for vibration calculation of rotors is proposed and tested. Research was also conducted using the Ansys software package. The error in determining the lower frequencies of free fluctuations of the mill rotors does not exceed 9%. Failure to take into account the elastic compliance of the rotor bearings leads to an error in determining the frequencies of free flexural fluctuations by no more than 15%, and the gyroscopic moment increases the above frequencies by no more than 25%. The cantilever arrangement of the disk reduces the frequencies of free fluctuations of the mill rotor by 1.1 - 1.4 times in comparison with the inter-support arrangement. The developed calculation procedure can be used in other industries, for example, mining and metallurgy.

## 1. Introduction

Knife refiners serve the main technological equipment for refining fibrous materials in the pulp and paper industry [1-4]. The main source of fluctuations of the mills and their supporting structures is the rotor imbalance [5]. The mill rotor performs various types of fluctuations including bending, longitudinal and torsional ones [6].

During refining, axial forces act on the rotor, which consist of constant, periodic and random components [7-9]. With the coincidence of the frequencies of free fluctuations of the rotor and the exciting forces, resonance occurs, while the dynamic loads and the amplitude of the fluctuations increase.

The purpose of the work is to study the flexural fluctuations of the mill rotor.

## 2. Methods and materials

### 2.1 Dynamic rotor model

Dynamic models of mill rotors can be restricted to two models: with a cantilever and an inter-support disk (figure 1). The rotor has axial symmetry and rotates with  $\omega$  frequency in the elastically damping radial anisotropic bearings  $O_1$  and  $O_2$ . We choose a fixed coordinate system XYZ so that the Y axis coincides with the axis of rotation of the shaft in its equilibrium position, and the XZ plane passes



through the center of mass of the disk. Supports have stiffness coefficients  $C_{iv}$  and damping  $b_{iv}$ ,  $i = 1, 2$ ;  $v = x, y$ . We will denote the central axial moment of inertia of the shaft by  $J_o$ , the equatorial (diametrical) moments of inertia by  $J_q$ , and the mass of the disk with the reduced mass of the shaft by  $m_2$ . We will connect the mobile coordinate system  $X'Y'Z'$  with the main axes of inertia. Static imbalance of the disk is represented in the form of a displacement of its center of mass by the value of the specific imbalance  $e$ , momentary imbalance will be represented in the form of the disk inclination in the position of its static equilibrium without taking its own weight into account at the angle  $\varepsilon$ .

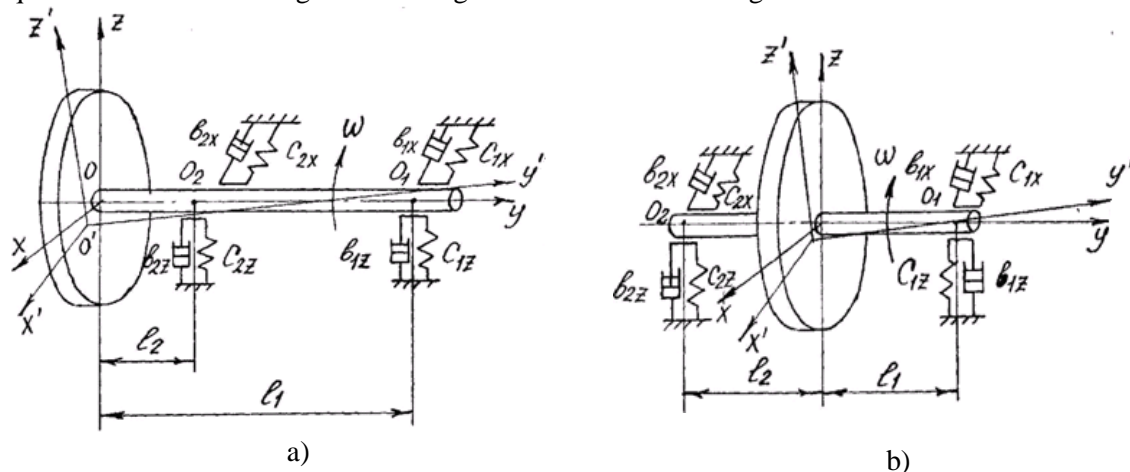

**Figure 1.** Dynamic models of mill rotors: a) with cantilever disk arrangement; b) with inter-disk arrangement.

2.2 Rotor mathematical model

The following assumptions are made: the study is conducted in a linear formulation; dispersion of fluctuation energy is taken into account only in supports; the inertia of rotation of the shaft section and shear strain are not taken into account; the mass of the rotor is applied at the center of mass of the disk; the influence of the thrust bearing is not taken into account; the drive is taken absolutely hard; the influence of longitudinal and torsional fluctuations is not taken into account; the main factors that excite the flexural fluctuations of the rotor are the imbalance of the disk and the axial force eccentrically applied to it.

The disk moves from the equilibrium position due to the displacement of the support points  $O_1$  and  $O_2$  and the elastic flexure of the shaft under the action of external forces and from static and dynamic imbalance. The position of the axis of rotation in space is determined by the points  $O_1$  and  $O_2$  with coordinates  $x_1, z_1$  and  $x_2, z_2$ . The position of the disk in space is determined by the coordinates of its mass center of  $x_c, z_c$  and the angles  $\gamma_c, \beta_c$  of the disk rotation in ZY and YX planes. These coordinates and rotation angles depend on the amount of displacement of the supports, on the size and shape of the deflection of the shaft, on the parameters  $e$  and  $\varepsilon$  of the disk unbalance and are determined by the formulas

$$x_c = x + e \sin \omega t, z_c = z + e \cos \omega t, \gamma_c = \gamma + \varepsilon \sin(\omega t - \varphi), \beta_c = \beta + \varepsilon \cos(\omega t - \varphi),$$

where  $x, z, \gamma, \beta$  are elastic displacements of the disk due to elastic deformations of the shaft  $x_0, z_0, \gamma_0, \beta_0$  and supports,  $\varphi$  is the angle of phase shift between the vectors of static and moment disk imbalance.

The projections on the fixed axes X and Z of the geometric derivative of the disk momentum will be equal to the projections on the same axis of the forces acting on the shaft side, and the projections of the

geometric derivative of the moment of momentum will be equal to the moments of the forces acting on the disk from the shaft [10], i.e.

$$\frac{d}{dt}(m_2 \dot{x}_c) = Q_x, \quad \frac{d}{dt}(\omega J_0 \gamma_c + J_g \dot{\beta}_c) = M_x, \quad \frac{d}{dt}(m_2 \dot{z}_c) = Q_z, \quad \frac{d}{dt}(-\omega J_0 \beta_c + J_g \dot{\gamma}_c) = M_z,$$

where  $Q_x, Q_z$  are forces acting on the disk from the shaft side,  $M_x, M_z$  are moments of forces acting on the disk from the shaft side.

Disk offsets  $x, z, \gamma, \beta$  can be expressed through the acting forces  $Q_x, Q_z$  and moments  $M_x, M_z$

$$x = -Q_x \delta_{11}^x - M_z \delta_{12}^x, \quad z = -Q_z \delta_{11}^z - M_x \delta_{12}^z, \quad \gamma = -M_z \delta_{22}^x - Q_x \delta_{21}^x, \quad \beta = -M_x \delta_{22}^z - Q_z \delta_{21}^z,$$

where  $\delta_{i,\vartheta}$  ( $i=1,2; \vartheta=1,2$ ) are influence coefficients;  $\delta_{11}^{x,z}$  is disk displacement under the action of a unit force applied to the disk, respectively, in the direction of the axis X, Z;  $\delta_{22}^{x,z}$  is disk rotation under the action of a single moment applied to the disk, respectively, around the axis X, Z;  $\delta_{12}^{x,z}$  is displacement of the disk under the action of a single moment applied to the disk, respectively, around the axis X, Z;  $\delta_{21}^{x,z}$  is rotation of the disk under the action of a unit force applied to the disk, respectively, in the direction of the axis X, Z.

We will obtain a system of equations describing the rotor fluctuations. To do this, we will solve the previously obtained equations together and introduce into them additional terms that take into account the dissipative forces in the system, which are taken proportional to the speed of the corresponding disk displacements  $b_v \dot{v}$  [10], where  $v = x, z, \gamma, \beta$ ;  $b_v$  are inelastic drag coefficients. We will introduce the notations

$$\begin{aligned} (\lambda_{11}^v)^2 &= \frac{1}{m_2 \delta_{11}^v}, \quad (\lambda_{12}^v)^2 = \frac{1}{m_2 \delta_{12}^v}, \quad (\lambda_{22}^v)^2 = \frac{1}{J_g \delta_{22}^v}, \quad \psi_v = \frac{b_v}{m_2 \lambda_{11}^v}, \quad \psi_{\gamma,\beta} = \frac{b_{\gamma,\beta}}{J_g \lambda_{11}^{x,z}}, \\ K_J &= \frac{J_0}{J_g}, \quad K_{22}^v = \frac{\delta_{12}^v}{\delta_{22}^v}, \quad K_{11}^v = \frac{\delta_{12}^v}{\delta_{11}^v}, \quad K_{11}^v = \frac{\delta_{21}^v}{\delta_{11}^v}. \end{aligned}$$

Substituting the notation into the resulting system of equations we will obtain a mathematical model that describes the fluctuations of the rotor

$$\begin{aligned} &\frac{1}{(\lambda_{11}^x)^2} \ddot{x} + \frac{1}{\lambda_{11}^x} \psi_x \dot{x} - K_J \frac{K_{22}^x}{(\lambda_{22}^x)^2} \omega \dot{\beta} + \frac{K_{22}^x}{(\lambda_{22}^x)^2} \ddot{\gamma} + x = \\ &= \frac{1}{(\lambda_{11}^x)^2} e \omega^2 \sin \omega t + (1 - K_J) \frac{K_{22}^x}{(\lambda_{22}^x)^2} \varepsilon \omega^2 \sin(\omega t - \varphi); \\ &\frac{1}{(\lambda_{11}^z)^2} \ddot{z} + \frac{1}{\lambda_{11}^z} \psi_z \dot{z} + K_J \frac{K_{22}^z}{(\lambda_{22}^z)^2} \omega \dot{\gamma} + \frac{K_{22}^z}{(\lambda_{22}^z)^2} \ddot{\beta} + z = \\ &= \frac{1}{(\lambda_{11}^z)^2} e \omega^2 \cos \omega t + (1 - K_J) \frac{K_{22}^z}{(\lambda_{22}^z)^2} \varepsilon \omega^2 \cos(\omega t - \varphi); \\ &-\frac{K_J}{(\lambda_{22}^x)^2} \omega \dot{\beta} + \frac{1}{(\lambda_{22}^x)^2} \ddot{\gamma} + \frac{1}{\lambda_{22}^x} \psi_\gamma \dot{\gamma} + \frac{K_{11}^x}{(\lambda_{11}^x)^2} \ddot{x} + \gamma = \\ &= \frac{K_{11}^x}{(\lambda_{11}^x)^2} e \omega^2 \sin \omega t + (1 - K_J) \frac{1}{(\lambda_{22}^x)^2} \varepsilon \omega^2 \sin(\omega t - \varphi); \\ &\frac{K_J}{(\lambda_{22}^z)^2} \omega \dot{\gamma} + \frac{1}{(\lambda_{22}^z)^2} \ddot{\beta} + \frac{1}{\lambda_{22}^z} \psi_\beta \dot{\beta} + \frac{K_{11}^z}{(\lambda_{11}^z)^2} \ddot{z} + \beta = \\ &= \frac{K_{11}^z}{(\lambda_{11}^z)^2} e \omega^2 \cos \omega t + (1 - K_J) \frac{1}{(\lambda_{22}^z)^2} \varepsilon \omega^2 \cos(\omega t - \varphi). \end{aligned}$$

### 3. Results and discussion

The frequencies of free flexural fluctuations of the rotor are determined from the mathematical model without taking into account inelastic resistances at  $e = 0$ ,  $\varepsilon = 0$  and substitution of solutions  $\mathbf{x} = \mathbf{A}_x \sin \omega_0 t$ ;  $\mathbf{z} = \mathbf{A}_z \cos \omega_0 t$ ;  $\boldsymbol{\gamma} = \mathbf{B}_\gamma \sin \omega_0 t$ ;  $\boldsymbol{\beta} = \mathbf{B}_\beta \cos \omega_0 t$ .

From the equality of the determinant of the obtained algebraic equations to zero, we will find the frequency equation, the real roots of which are the frequencies of free fluctuations of the rotor

$$\omega_{01,02} = \sqrt{\frac{\left(1 - \frac{\omega}{\omega_0} K_J\right) \lambda_{11}^2 + \lambda_{22}^2 \mp \sqrt{\left[\left(1 - \frac{\omega}{\omega_0} K_J\right) \lambda_{11}^2 + \lambda_{22}^2\right]^2 - 4 \left[\left(1 - \frac{\omega}{\omega_0} K_J\right) - \left(1 - \frac{\omega}{\omega_0} K_J\right) K_{11} K_{12}\right] \lambda_{11}^2 \lambda_{22}^2}}{2 \left[\left(1 - \frac{\omega}{\omega_0} K_J\right) - \left(1 - \frac{\omega}{\omega_0} K_J\right) K_{11} K_{12}\right]}}$$

The rigidity of the supports significantly affects the frequency of free rotor fluctuations. Failure to take into account the elastic compliance of bearings, the elastic compliance of which in the vertical direction is sufficiently small, leads to an error in determining the lower frequencies of free flexural fluctuations of the mill rotor in this direction by no more than 15% in the direction of their increase. Since the elastic flexibility of the bearings in the horizontal direction substantially depends on the magnitude of the radial clearance in the bearings, the frequencies of free flexural fluctuations of the rotor in this direction will depend on the magnitude of the above clearance. Vibration activity of mills during design can be controlled by the introduction of elastic supports of a special design [6].

For mill rotors  $\lambda_{11}/\omega_0 > 1$  and  $J_0 > J_q$ . Therefore, the gyroscopic moment increases the natural frequencies of the rotors, moving them away from the resonant frequencies. The influence of the gyroscopic moment on the natural frequencies of the rotors of existing mills does not exceed 25%. With vibration isolation of the rotor bearings, when it oscillates in the out-of-resonance mode, the gyroscopic moment lowers the frequencies of free fluctuations of the rotors, also removing them from resonant frequencies. The studies were also carried out on rotor models with cantilever and inter-support disk locations using the Ansys computer software package. The main result of research is the determination of the forms and frequencies of free fluctuations (figure 2). Using modal analysis, the frequency composition of free fluctuations was classified and a comparative analysis of rotors with inter-support and cantilever disk arrangements was carried out (table 1). The location of the disk significantly affects the number of modes of the rotor flexural fluctuations (four modes for inter-support arrangement and six modes for cantilever). The cantilever arrangement of the disk lowers the frequencies of free rotor fluctuations of the mills by 1.1 - 1.4 times in comparison with the inter-support arrangement.

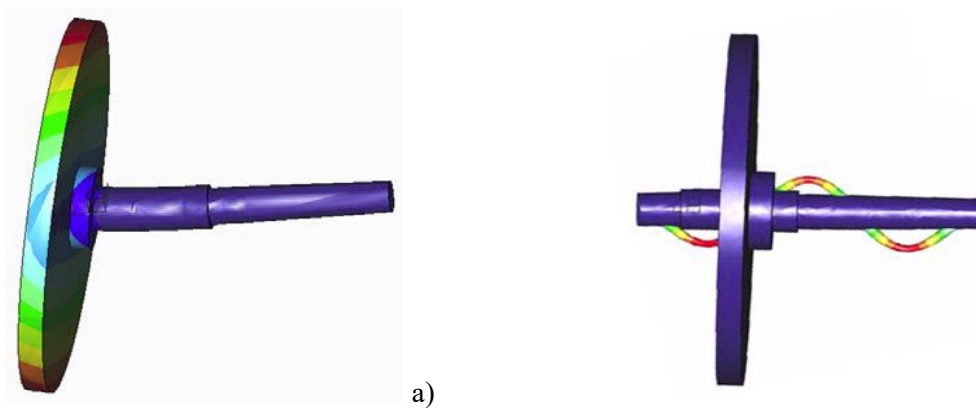

**Figure 2.** Forms of flexural fluctuations of the rotor model: a) MD-31 mill at a frequency of 42 Hz; b) MDS-33 mill at a frequency of 75 Hz.

**Table 1.** Frequencies of free flexural fluctuations of mill rotors.

Free fluctuation frequency number	Frequency of flexural fluctuations, Hz							
	MD-31 mill with cantilever disc arrangement				MDS-33 mill with inter-disk arrangement			
	Calculation	Modal analysis	Experiment	Error, %	Calculation	Modal analysis	Experiment	Error, %
1	45	42	44	2/5	51	58	53	4/9
2	78	73	75	4/3	72	75	73	2/3
3	-	126	-	-	-	138	-	-
4	-	221	-	-	-	240	-	-
5	-	403	-	-	-	-	-	-
6	-	785	-	-	-	-	-	-

#### 4. Conclusion

A method for calculating the flexural fluctuations of the mill rotor was developed and tested, taking into account the anisotropy of the supports, the elastic ductility of the shaft, the action of the gyroscopic moment, and the position of the disk relative to the supports. The error in determining the frequencies of free flexural fluctuations of the mill rotors does not exceed 9%.

Failure to take into account the elastic compliance of the bearings leads to an error in determining the lowest frequencies of free fluctuations of the rotors by no more than 15%.

The gyroscopic moment increases the frequency of free fluctuations of the rotors by no more than 25%.

The cantilever arrangement of the disk reduces the frequencies of free fluctuations of the rotor of the mills by 1.1 - 1.4 times in comparison with the inter-support arrangement.

The developed calculation procedure can be used in other industries, for example, mining and metallurgy.

#### References

- [1] Ivanov S N 2006 *Paper technology* (Moscow: Forest industry)
- [2] Byvshev A V and Savitskiy E E 1991 *Mechanical dispersion of fibrous materials* (Krasnoyarsk: Krasnoyarsk university publ)
- [3] Legotsky S S and Goncharov V I 1990 *Refining equipment and pulp preparation* (Moscow: Forest Industry)
- [4] Korda I and Libnar Z 1967 *Paper mass grinding* (Moscow: Forest production)
- [5] Vikharev S N 2019 *IOP Conf. Ser.: Mater. Sci. Eng.* **537** 032021
- [6] Vikharev S N 2019 *IOP Conf. Ser.: Mater. Sci. Eng.* **537** 032015
- [7] Vikharev S N 2019 *IOP Conf. Ser.: Mater. Sci. Eng.* **537** 032008
- [8] Olender D and Wild P 2007 Forces on Bars in High-Consistency Mill-Scale Refiners. Trends in Primary and Rejects Stage Refiners *J. Pulp Paper Sci.* **33** (3) 163
- [9] Berg J K, Sandberg C, Engberg B A 2015 Low consistency refining of mechanical pulp in the light of forces on fibers *Nord. Pulp Pap. Res. J.* **30** (2) 225
- [10] Chelomey V N 1980 *Vibration and Engineering: A Handbook* (Moscow: Machinebuilding)