

EIT-Innoenergy Joint Master's Program

## **Energy for Smart Cities**

# **Energy storage systems for smart meter privacy: a study of public perceptions**

### **Master Thesis Report**

**Author:** Shilpa Bindu  
**Supervisor:** Andreas Sumper, UPC Barcelona  
**Research supervisor:** Daniel Månsson, KTH Stockholm



Escola Tècnica Superior  
d'Enginyeria Industrial de Barcelona





## Abstract

Smart meters are a vital step for transitioning to a smart grid architecture. Studies have shown that it is possible to extract appliance usage information through non-intrusive load monitoring methods. This data can be used by third-parties for unwanted activities like targeted marketing, home invasion, etc. It is postulated that the data leakage will be minimum when the power flow from/to the grid is piecewise linear.

To achieve linearity, the use of energy storage systems is investigated. Energy storage systems (ESS) are being increasingly used by customers having solar energy production. In this project, an algorithm for the energy management unit (EMU) to control the ESS is proposed which maintains piecewise linearity. Two types of users are considered for the study: 1. user who injects excess energy to the grid 2. user who does not (or is not allowed by law) to inject power to the grid. The effect of the algorithm on both users is studied.

The minimum capacity of ESS for data leakage prevention is analysed for both cases. Data from four different households is used in different combinations to obtain the mean capacity required. Using this data, an equation is formulated for the minimum capacity of ESS required to maintain linearity in power flows.

The second part of the study is to understand how people perceive smart meter privacy issues and how much they are willing to spend for mitigating privacy breaches. The survey is done in Sweden. Sweden was the first European country to have 100% smart meter roll-out. In 2020, the smart meters installed during the first roll-out will reach their economic lifespan. Hence, the country is preparing for a second-generation mass roll-out of smart meters.

The perception of people regarding smart meters is identified from two perspectives. First, the consumers are directly surveyed for estimating their awareness of smart meter privacy problems and their willingness to invest in technologies that prevent such issues. Second, different stakeholders in smart metering are surveyed regarding their experience during first and second roll-out. The methods currently employed to safeguard consumer data is also explored during the second survey.



## Acknowledgement

I would like to express my heartfelt gratitude to my supervisor, Daniel Månsson, who not only was a brilliant guide but a teacher who inspires his students to think. I also like to acknowledge the help and support provided by my academic supervisor, Andreas Sumper. His research areas have fascinated me so much, and it was a great opportunity to be guided by an expert like him.

I express my sincere gratitude to Innoenergy for giving me a wonderful opportunity to study in two amazing universities and for all the help and support that was provided along the way. I could not have done this project without the help from Hans Edin, Director of Innoenergy SENSE program.

This study involved surveying Swedish consumers which was a challenging task for me. I appreciate the kindness of everyone who completed the questionnaire and shared it with their friends. I am so grateful to all the wonderful people who helped me in completing the expert opinion survey. Though it was personal curiosity that made me contact the companies at first, the discussions that I had with them were so interesting that convinced me to proceed with it.

Finally, I would like to thank my parents for their love and support, my sister for all the witty conversations, Hari for tolerating all my thesis moods and Saraswathy for being the best friend she is. Thanks to everyone who has inspired, criticized, and shaped this project along the way.



# Contents

<b>ABSTRACT</b>	<b>3</b>
<b>ACKNOWLEDGEMENT</b>	<b>5</b>
<b>CONTENTS</b>	<b>7</b>
<b>GLOSSARY</b>	<b>9</b>
List of Abbreviations.....	9
List of Tables.....	11
List of figures.....	12
<b>1. INTRODUCTION</b>	<b>15</b>
1.1. Objectives.....	17
1.2. Methodology.....	17
<b>2. SMART METERS</b>	<b>19</b>
2.1. Minimal Functionality Requirements of SM.....	20
2.2. Privacy Concerns Related to SM.....	23
2.3. Data privacy in the EU legislature.....	24
2.4. Protection and Mitigation.....	26
2.5. Summary.....	29
<b>3. ENERGY STORAGE SYSTEMS FOR SMART METER PRIVACY</b>	<b>30</b>
3.1. Residential PV systems.....	30
3.2. Effect of PV production on consumption curves.....	32
3.3. Algorithm for ESS charging and discharging.....	35
3.4. Sizing ESS for SM data privacy.....	38
3.5. Results.....	43
3.6. Summary.....	46
<b>4. PUBLIC PERCEPTIONS REGARDING SMART METER PRIVACY ISSUES</b>	<b>47</b>
4.1. Public acceptance of RES.....	48
4.2. Surveys for understanding public perception.....	50
4.3. Survey Methodolgy.....	51
4.4. Results.....	52
4.5. Smart meter privacy in Sweden: perspective of the companies.....	55
4.6. Summary.....	57

<b>5. DISCUSSION</b>	<b>59</b>
5.1. Summary of findings .....	60
5.3.1 Sizing of ESS for mitigating privacy issues .....	60
5.3.2 Study of public perceptions .....	61
5.2. Limitations.....	63
5.3. Suggestions for further research.....	64
<b>CONCLUSION</b>	<b>66</b>
<b>BIBLIOGRAPHY</b>	<b>69</b>



# Glossary

## List of Abbreviations

<i>BESS</i>	<i>Battery Energy Storage Systems</i>
<i>BTM</i>	<i>Behind-the-Meter</i>
<i>DG</i>	<i>Distributed Generation</i>
<i>DoD</i>	<i>Depth of Discharge</i>
<i>DPIA</i>	<i>Data Protection Impact Assessment</i>
<i>DR</i>	<i>Demand Response</i>
<i>DSM</i>	<i>Demand Side Management</i>
<i>DSO</i>	<i>Distribution System Operator</i>
<i>EC</i>	<i>European Commission</i>
<i>ECC</i>	<i>Elliptic Curve Cryptography</i>
<i>ECHR</i>	<i>European Convention on Human Rights</i>
<i>EDPS</i>	<i>European Data Protection Supervisor</i>
<i>EMU</i>	<i>Energy Management Unit</i>
<i>ESS</i>	<i>Energy Storage Systems</i>
<i>EU</i>	<i>European Union</i>
<i>EV</i>	<i>Electric Vehicles</i>
<i>GDPR</i>	<i>General Data Protection Regulation</i>
<i>NILM</i>	<i>Non-Intrusive Load Monitoring</i>
<i>PHEV</i>	<i>Plug-In Hybrid Vehicles</i>

---

<i>PKI</i>	<i>Public Key Infrastructure</i>
<i>PPP</i>	<i>Privacy Preserving Models</i>
<i>PTS</i>	<i>Post and Telecom Authority</i>
<i>PV</i>	<i>Photovoltaic</i>
<i>REDD</i>	<i>Reference Energy Disaggregation Set</i>
<i>RES</i>	<i>Renewable Energy Source</i>
<i>RF</i>	<i>Radio Frequency</i>
<i>SDC-Nets</i>	<i>Symmetric DC-Nets</i>
<i>SDPA</i>	<i>Swedish Data Protection Agency</i>
<i>SG</i>	<i>Smart Grid</i>
<i>SM</i>	<i>Smart Meter</i>
<i>SOC</i>	<i>State of Charge</i>
<i>V2G</i>	<i>Vehicle-to-grid</i>
<i>WTP</i>	<i>Willingness to Pay</i>

## List of Tables

Table 2.1 List of recommended ten common minimum functional requirements for smart metering systems .....	21
Table 2.2 Minimum functionalities suggested by the Swedish Government for second large scale SM roll-out.....	21
Table 3.1 Mean and variance of the average daily consumption of the households.....	43
Table 4.1 Demographics of the survey .....	52

## List of figures

Figure 1.1 Share of renewable sources in EU member states .....	17
Figure 2.1 The timeline of SM deployment in EU member states .....	19
Figure 2.2 Household Electricity Demand Profile (measurements in one-minute intervals)..	23
Figure 2.3 Masking of consumption curve using noise addition .....	28
Figure 2.4 Charging and discharging of the batteries that partially decouples the information flow.....	29
Figure 3.1 System prices of PV panels (excluding VAT) over the years.....	31
Figure 3.2 The duck curve.....	32
Figure 3.3 Household with PV panels but without ESS .....	33
Figure 3.4 The consumption, generation and grid supplied power of a household with PV in absence of an ESS .....	34
Figure 3.5 Household with PV panels and an ESS .....	35
Figure 3.6 The consumption, generation and grid supplied power of a household with PV along with an ESS. The green curve represents the energy level of the ESS during the day. ....	38
Figure 3.7 The algorithm implemented for charging and discharging the ESS.....	40
Figure 3.8 The effect of increasing the ESS capacity on charging cycles during a 48-hour span. The considered user does not sell energy to the grid .....	42
Figure 3.9 Surface plot of minimum ESS capacity requirement .....	45
Figure 4.1 Domestic Electricity Meters in UK (31 March 2019). ....	47
Figure 4.2 Percentage of responses for the given answer choices .....	54
Figure 5.1 The dependence of the lifetime of a lead-acid battery on the number of cycles and the DoD.....	60





# 1. Introduction

Electricity meters are used to measure the amount of energy consumed by a customer mainly for billing purposes. When the electricity markets started getting deregulated, it initiated a market-driven pricing where the time of consumption became decisive. The early models of electricity meters only measured the energy consumed and relied on manual meter readings at an interval of one or two months. Manual meter readings at an hourly basis were extremely expensive and impractical for the utilities. Hence, a need for automated remote metering emerged in the deregulated markets.

Automated readings had many added advantages like increased billing accuracy and better demand management. As consumers started investing in renewable energy generation sources like solar panels, meters had to evolve to measure the bidirectional flow of energy. The latest smart meter (SM) models are designed to have real-time measurements, power outage notification and power quality measurement. Thus, smart meters have become a vital part of smart grid systems [1].

The multidirectional communication through a smart grid system raises a potential threat where the smart meters can be an easy target. Studies have shown that it is possible to determine the behavioral pattern of the residents from smart meter data via Non-Intrusive Load Monitoring (NILM). If not handled properly, SM data can be used by third parties for a wide variety of reasons including targeted marketing to home invasions or theft. This constitutes a breach of the user's privacy, resulting in protests against SM deployment in some countries.

The growing concerns over the possibility of a privacy breach and its implications, lead to interesting research questions. Several possible approaches to mitigate the privacy invasion have been suggested but one possibility is to use an energy storage system (ESS) and a control unit (energy management unit, EMU). The EMU and the ESS will dynamically manipulate the required (i.e., bought) amount of power for the user for a given moment in time according to a predefined control scheme or algorithm. Thus, the real consumption profile of the user is not revealed.

Recently, personal data has become one of the biggest sources of targeted marketing. A patent submitted by a smart TV company reveals the design for in-house targeted marketing through image and audio sensors. Inside an identification zone, the TV will be able to study the physical attributes, voice attributes to study a user, identifies who is watching the TV, what action they are performing and selects an advertisement based on the identified data [2]. Such innovations might seem harmless at first but recent events have shown the rising demand for user data, not just for marketing but also for political campaigning [3]. Hence, it is very important that people should be aware of the type of information collected by the SM and also, how it is

used.

ESS falls in the category of Behind the Meter (BTM) technologies which require involvement from the customer side. Although researchers can prove the usefulness of a solution, without awareness from consumers, it is not possible to prevent the issues. Therefore, it is important to know the awareness level among people and their willingness to invest in preventive technologies.

### **The country of study: Sweden**

Sweden is the first country in the European Union (EU) to achieve 100% automated meter reading system in 2009. The conditions leading to such a widespread roll-out of SM are discussed in the next chapter. Sweden is preparing for the second massive roll-out of SMs from 2020, as the meters installed during the initial roll-out have reached their economic lifespan [4]. Sweden is also in the forefront of European renewable energy transition.

Sweden is one of the EU countries that met their renewable energy target for 2020, as mandated by Directive 2009/28/EC, ahead of time. The directive mandates, for each member state, a national overall target for the share of energy from the renewable sources such that the gross final consumption of renewable energy in the EU reaches 20% by the year 2020. From 11.3% in 2008, this share has risen to 17.5% in 2017. Out of 18 countries, 11 have already met their targets by 2017 [5]. According to this target, the share of energy from renewable sources in Sweden had to increase from 38.8% in 2005 to 49% by 2020 [6].

Sweden, along with setting many ambitious goals in abidance with the directive, raised the national renewable energy share target to 50% and aimed to increase the energy efficiency by 20% within 2020[7]. This target was met in 2012, primarily due to the increased use of biofuels [8][9][10]. The status of share of renewables in other EU countries in 2017 is given in Figure 1.1

EU Directive relating to building performances dictates the standards to be met by the energy use in buildings. By 2020, all new buildings should be zero energy buildings [11], [12]. In order to achieve this criterion, the Swedish government has been offering various schemes and support for the installation and maintenance of self- produced electricity. Mostly, these are offered as monetary support, for e.g. photovoltaic systems and solar heating systems receive 20% of installation cost and energy storage systems receive a maximum of 50,000 SEK<sup>1</sup> [13].

The ambitious goals in the sector of green technologies along with the methodologies accepted to abide by it make Sweden a suitable country for this study.

---

<sup>1</sup> 1 SEK ~ 0.104 USD (September 2019)



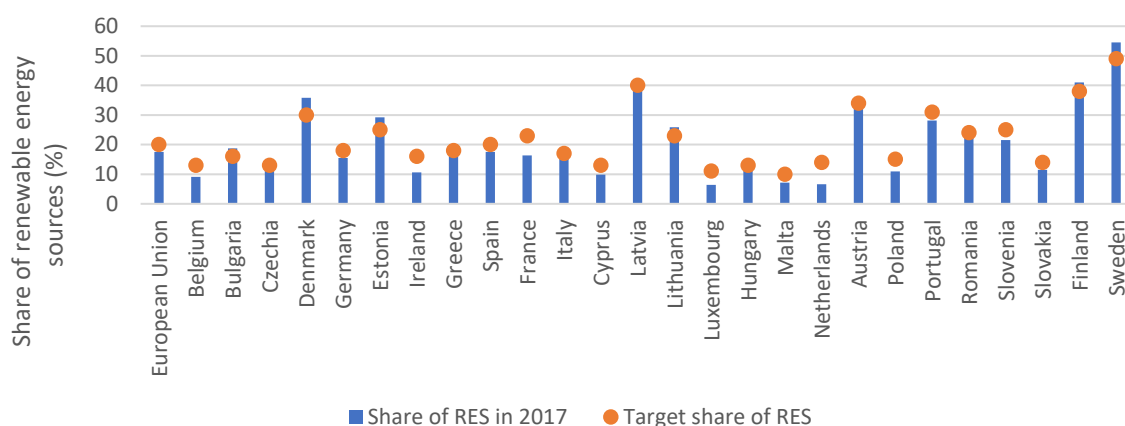

Figure 1.1 Share of renewable sources in EU member states. Source: Eurostat [6][5]

## 1.1. Objectives

The energy consumption curves can be a good source of information for intruders. Even though the SM readings are accumulated over a period, advanced pattern processing methods can easily categorize the patterns to the level of individual appliances. Hence, the main aim of the study is to determine the minimum capacity of an ESS which can manipulate the generation and consumption curves in a household. Two cases are to be considered 1) a consumer without any solar power generation 2) a prosumer with solar power generation.

The second part of the project is to study the public perception about the smart meter privacy issues. The study aims to find out whether there is any correlation between various factors like environmental awareness, type of occupation and willingness to invest in privacy preserving technologies. The main challenges and opportunities within smart metering is to be investigated from different energy companies.

From the first part, it is possible to estimate the ESS capacity required for privacy preservation. The cost of the ESS required can be compared to the survey results to see whether consumers are willing to invest in ESS.

## 1.2. Methodology

In this study, an ESS is used to mitigate the privacy issues of the SM. The minimum capacity of ESS required to successfully mask the consumption curve of the household, for different values of energy consumption and solar energy generation, is determined and is used to formulate the minimum capacity of ESS required for a given value of consumption and solar energy production. The simulations were done in MATLAB [14].

The dataset used for the study is obtained from the Reference Energy Disaggregation Data Set (REDD) [13]. It is a freely available data set with detailed power usage information collected from different households. The data for solar energy generation is obtained from a website (PVOutput.org) which shares and monitors live solar photovoltaic energy generation. Two photovoltaic (PV) outputs are used for the study, from a panel of rating 2.88 kW and 5.28 kW, both panels are situated in northern Denmark (latitude 56.4697 ° N). Cities in Southern Sweden almost falls in the same latitude, for e.g., Malmö- 55.6050° N.

The second part of the study reviews the perception of people about SMs and privacy threats. A sample of Swedish residents was surveyed to identify their preferences about installing solar panels and investing in SM privacy-enhancing technologies. The surveys responses were collected mainly through online questionnaires and street surveys. In addition to the survey of consumers, an interview of industry experts in smart metering is done. This helped in understanding the current state of SM functionalities, energy services provided and the methodologies implemented for secure data transmission. The interviews were taken from experts from E.ON (an electric utility company), Ellevio A.B (a Swedish distribution system operator), OneNordic (smart meter provider), Power2U (an energy services company), Swedish Data Protection Agency (SDPA) and Swedish Post and Telecom Authority (PTS).

The report is divided into three main chapters, spanning the topics discussed in the introduction.

Chapter 1 is about the history of SMs in the EU and the possible privacy threats. A detailed literature review on SMs and privacy invasion is presented here along with various legislature regarding data protection. For a social perspective, the case of smart meter roll-out in The Netherlands is presented. The chapter discusses the current methodologies to prevent SM data leakage.

In Chapter 2, a detailed report of how ESS can be used for manipulating the consumption data profile is given. The minimum capacity of ESS required to mask the consumption profile is calculated as a function of the average household consumption and solar production.

In Chapter 3, the results of the survey and the interview are presented. The results show SM privacy issues from different perspectives (end-user, regulatory authorities, utilities and energy service companies).

Results and discussion is presented as the last chapter. A comparison of the actual cost of ESS with the spending limit of the surveyed group is presented. Inferences are drawn from the studies and the future scope of the project is discussed.

## 2. Smart Meters

There are different reasons for the rollout of smart meters in different countries. A time-varying cost system was thought to reduce the peak hour consumption, which was the motivation for many countries like Finland. On the other hand, in Sweden, it was mainly due to the consumer complaints about unclear billing system. The electricity market in Sweden was fully deregulated in 1996, providing the customers with an option to change the energy deliverer if hourly reading was installed. The load profiling reform of 1999, allowed the consumers at low voltage to change their electricity retailer without having an hourly reading of their energy meter. The deregulation of the electricity market was followed by soaring energy prices, calling for market transparency and billing accuracy. In 2006, an amendment to this legislation was made, necessitating all the consumers having a fuse of 63A or less to have a monthly reading of their energy meter. The most cost-effective way to perform this was to invest in remote meter reading technology. This eventually led to the nationwide deployment of smart meters between 2006 and 2009, making Sweden the first country to have almost 100% smart meters [15], [16], [4].

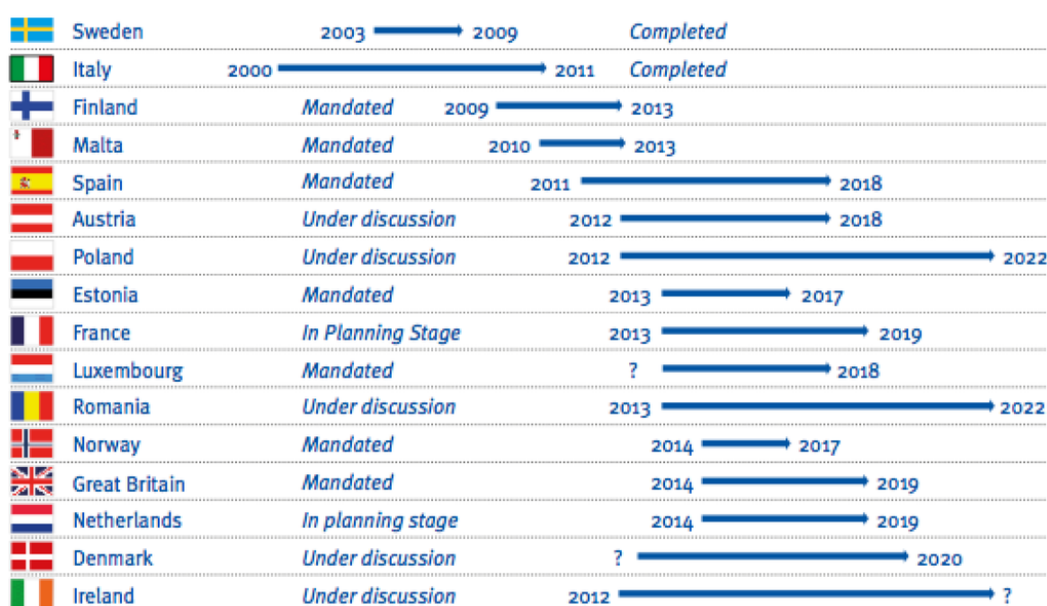

Figure 2.1 The timeline of SM deployment in EU member states [5]

European legislation has also played a significant role in smart meter deployment throughout the member states. To achieve a single European electricity and gas market based on competitive pricing and customer's right to choose the supplier, the EU decided to adopt an 'open energy market' by 1 July 2007. This was a part of the Second Energy Package, which initiated the liberalization of the European energy markets. European legislation on different

energy services like energy end-use efficiency and energy services (EU Directive 2006/32/EC Article 13), measurements to safeguard the security of electricity supply and infrastructure investment (EU directive 2005/89/EC Article 5) had further promoted the use of advanced metering devices for real-time demand management and reasonable pricing[1]. Sweden was among the thirteen-member states that had already opened its electricity market before the date [17]. The timeline of SM deployment in EU member states is given in Figure 2.1

The timeline of SM deployment given in Figure 2.1 is from an EU documentation in 2014. Many of the nations can be seen to be fully equipped with smart meters by 2018-2019. But by the time of writing, many countries have experienced lag in SM roll-out. Both France and Austria have not completed their SM roll-out in 2019 and are planning to achieve it by 2020. Netherlands has mandated the use of SMs by 2020 [18].

Smart Grids (SG) are vital components in the shift from centralized conventional electricity generation to decentralized distributed generation. SGs allows a bidirectional flow of energy and information, enabling an automated, efficient, and advanced energy delivery network. Smart meters can support other SG components as it can provide efficient power system control and timely operational decisions to minimize outages and losses. SMs are also equipped for scheduling preventive maintenance, fault analysis and detection of unwanted harmonics. SMs are particularly beneficial for utilities in case of an outage as it reduces the workforce needed to collect information and provides critical data for the restoration. Also, with rising penetration of plug-in hybrid vehicles (PHEVs) and electric vehicles (EVs), SMs can be advantageous in monitoring, controlling, and metering the energy use. Hence, SMs are considered as the first step towards advancing into an SG network [19][20][21].

## 2.1. Minimal Functionality Requirements of SM

Although the reasons for SM roll-out differ across the countries, their functionalities remain similar, owing to EU Recommendation 2012/148/EU. It includes ten minimum functional requirements for smart metering systems (see Table 2.1). To ensure interoperability between SMs from different companies, specific standards for communication, data management, and operations have to be followed by the manufacturers [9][10].

For the efficient use of consumption data, a minimum interval of 15 minutes is recommended. The meters in Sweden are set for hourly readings: hence, Sweden partly meets functionality (b) and fully meets all other functionalities [22].

A report from Vattenfall, an energy utility company that installed about 850,000 AMR devices in Sweden during the first mass roll-out, shows that all the installed meters are equipped with hourly reading, power outage reporting, and remote load control functionalities. 70% of the

installed meters are also able to perform advanced functionalities like remote upgrading, power quality reporting, and tamper detection [23]. With the conventional energy meters, it is challenging to obtain power flows and power quality, complicating the shift to a smart grid system. The information obtained from the SMs is crucial here, as it can help in identifying the effects of the penetration of renewable sources into the grid [24].

*Table 2.1 List of recommended ten common minimum functional requirements for smart metering systems. Adopted from cost-benefit analysis of SM deployment b European Commission [25]*

<b>Consumer</b>	a. Provide readings directly to the consumer and/or any 3 <sup>rd</sup> party b. Update readings frequently enough to use energy saving schemes
<b>Metering Operator</b>	c. Allow remote reading by the operator d. Provide 2-way communication for maintenance and control e. Allow frequent enough readings for networking planning
<b>Commercial Aspects of Supply</b>	f. Support advanced tariff system g. Remove ON/OFF control supply and/or flow or power limitation
<b>Security – Data Protection</b>	h. Provide secure data communications i. Fraud prevention and detection
<b>Distributed Generation</b>	j. Provide import/export and reactive metering

SMs can separately measure the energy fed to the grid and the energy taken from the grid. It can also be utilized to remotely control a distributed generation (DG) system [19], [26], [27].

A second large scale roll-out of SMs is planned in Sweden for 2020, as the SMs installed during the first phase reaches their economic lifespan [4]. An updated set of minimum functional requirements were put forward by the Swedish Government to ensure uniformity and foster competition among different market participants. The new functionalities suggested by the governments is described in Table 2.2. During the second roll-out, almost 5 million SMs are expected to be installed before 2025 [4].

*Table 2.2 Minimum functionalities suggested by the Swedish Government for second large scale SM roll-out. Adopted from Summary of the report from Ei about smart meters [4]*

<b>No</b>	<b>Functionality</b>	<b>Purpose</b>
1	The meter should (for every phase) be able to	Promotes efficient network

	measure voltage, current, active and reactive power for withdrawal and input of electricity. The meter should also be able to measure and register the total energy for withdrawal and input of electricity	operation. Facilitates integration of micro production in the network.
2	The meter should be equipped with a customer interface, supported by an open standard, for the customer to be able to take part of the measured values (see functionality no. 1) in near real time. It should not be possible to send information to the meter through the interface. The interface needs to be activated by the distribution system operator (DSO), on request by the customer, to provide information. The DSO should control the identity of the user and must deactivate the interface when the customer moves out.	Creates conditions for a developed energy services market. Promotes demand side flexibility and energy efficiency. Increases customer empowerment.
3	The DSO should be able to read the measured values remotely (with remote control)	Promotes efficient collection of meter data
4	The meter should be able to measure the energy for every hour and be able to convert to measure the energy for every fifteen minutes.	Increases the customers possibility to be active (participate) in the market.
5	The meter should be able to register data about the beginning and end of a power outage in one or more phases, that is three minutes long or more.	Facilitates for the DSOs to pay compensation to the customer for interruptions longer than 12 hours and to report data to Ei. Empowers the customer.
6	The DSO should be able to update software and change settings of the meter with remote control.	Provides that new functionalities can be introduced in a cost-efficient way. Expensive field visits can be avoided.
7	The DSOs should be able to turn on and off the power through the meter with remote control. This requirement only applies for meters that are not transformer connected	Facilitates for the DSOs to turn off the power if the customer moves out.

## 2.2. Privacy Concerns Related to SM

In 2009, a smart worm simulation opened the possibilities of a large-scale cyber-attack on the connected electric and communication networks. The smart worm simulated by a security service company was able to spread to 15,000 meters out of 22,000 meters connected within 24 hours [18], [19]. The demonstration was done to increase awareness among the consumers and the meter companies on how lack of encryption service can lead to a leakage of data and spreading of malicious software programs. Since then, intensive research has been carried out to find out the SM privacy flaws and to identify potential solutions for the same.

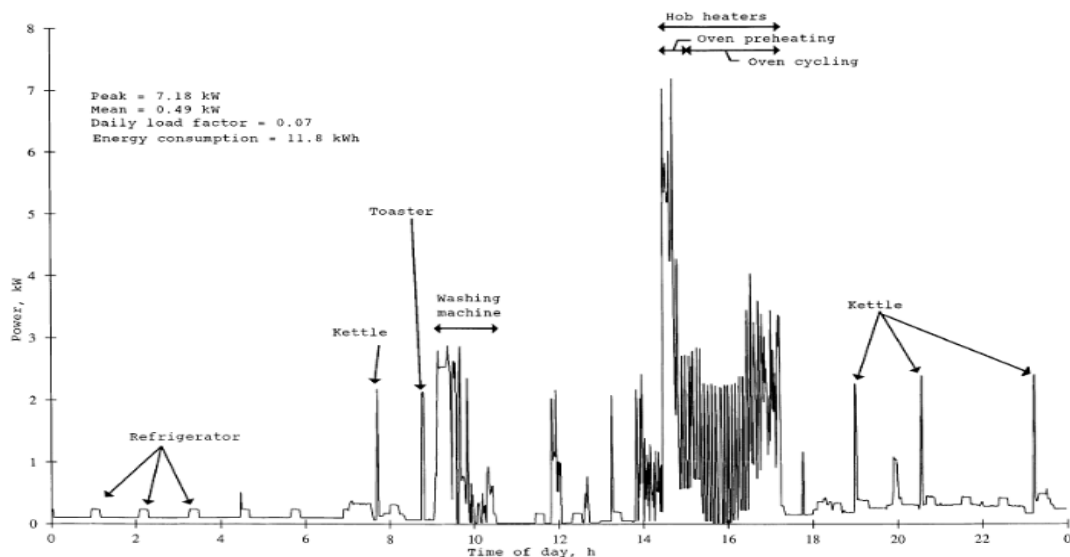

Figure 2.2 Household Electricity Demand Profile (measurements in one-minute intervals) [23]

The electricity usage pattern shows noticeable changes when occupants are present and when they are not. The appliance usage pattern can be tracked through Non-intrusive Load Monitoring (NILM) algorithms (see Figure 2.2). NILM algorithms were developed in 1992 to ease the collection of energy consumption data by utilities [14]. It determines the energy consumption of individual appliances turning on and off based on detailed analysis of the current and voltage as measured at the interface to the power source. NILM algorithms have been widely used to identify the appliance usage from metering data collections [20]. Studies have shown that even without previous knowledge of household activities, it is possible to extract information on intricate usage pattern [21]– [23].

NILM is a very advanced field of studies, and researchers in this area have been able to come up with many innovative solutions like monitoring of the elderly using SM data only [28]. The problem arises when a third party accesses the SM data and uses the knowledge of their behaviour for theft or home invasion. Using NILM, SM data can even be used to know more



about the religious practises undertaken by the inmates (for example, during Ramadhan) or for monitoring the health of an inmate (tracking of dialysis machines or related equipments).

The accuracy of the extracted information depends on the measurement interval. For example, five minutes of consecutive playing of a movie is sufficient to identify the viewed content by analysing the SM data [29]. If the measurement duration is more than half the typical operating duration of an appliance, the precision of tracking decreases drastically. Measurements at 15-minute intervals can track only appliances operating for longer durations like light bulbs and refrigerators [30].

The privacy infringement due to SM can occur due to different reasons and from different sources [31]–[34], [35].

- Marketing agencies: The knowledge of user patterns can help in targeted advertising. From SM readings, it is easy to identify the period of occupancy, number of people, etc. which can be utilized accordingly.
- Criminals: Thieves can target the houses after identifying when the homes are unoccupied
- Law enforcement agencies: Law enforcement agencies have access to the utility bills which is routinely used to search for drug producers (abnormal consumption patterns due to heat lamps and watering systems used for growing marijuana indoors).
- Anti-social elements: Hacking the system to disconnect households or even hospitals and police stations
- Other parties: Custody battle of children- leaving children alone, a tenant-landlord dispute about overoccupancy

### 2.3. Data privacy in the EU legislature

Several legal obligations bind SM data in the EU.

The European Parliament Directive 95/46/EC states that “*whereas data-processing systems are designed to serve man; whereas they must, whatever the nationality or residence of natural persons, respect their fundamental rights and freedoms, notably the right to privacy, and contribute to economic and social progress, trade expansion and the well-being of individuals*”. According to this Directive, data processing is allowed only if an unambiguous consent is given by the owner or if the processing is necessary for compliance with a legal obligation (Article 7) [36].



Along with this Directive, another relevant legislation concerning the SM privacy issue is Article 8 of the European Convention on Human Rights (ECHR). The structure of Article 8 is as follows:

1. *Everyone has the right to respect for his private and family life, his home, and his correspondence.*
2. *There shall be no interference by a public authority with the exercise of this right except such as is in accordance with the law and is necessary in a democratic society in the interests of national security, public safety or the economic well-being of the country, for the prevention of disorder or crime, for the protection of health or morals, or for the protection of the rights and freedoms of others [37].*

The EU General Data Protection Regulation (GDPR) is one of the most recent data privacy regulation. For analyzing the scope of SG data privacy within GDPR, the European Commission (EC) set up a Smart Grids Task Force consisting of five Experts Group on different area, of which Expert Group 2 is in charge of SM privacy risks and mitigation. The GDPR requires that “*where a type of processing in particular using new technologies, (...) is likely to result in a high risk to the rights and freedoms of natural persons, the controller shall, prior to the processing, carry out an assessment of the impact of the envisaged processing operations on the protection of personal data*”. The EC, along with Expert Group 2, developed a template for carrying out a Data Protection Impact Assessment (DPIA) where controller, in this case, is the DSO [38].

GDPR functions as a general framework for data protection and hence, a new proposal for an Electricity Directive (common rules for the internal market in electricity, recast) was made. It states that “*Currently different models for the management of data have been developed or are under development in the Member States following the deployment of smart metering systems. Independently of the data management model, it is important that Member States put in place transparent rules under which data can be accessed under non-discriminatory conditions and ensure the highest level of cybersecurity and data protection as well as the impartiality of the entities which handle data*” [39].

The presence of these privacy policies is pivotal in preventing data misuse.

#### **Case Study: Smart Meter Deployment in The Netherlands**

In July 2008, the Dutch government passed bills for the introduction of SMs in Dutch households. Even though the bill was a consequence of the EC Directive on energy efficiency, the disadvantages of SMs were also identified. The electricity measurements taken in 15-minute intervals contain extractable personal information in it, which will, in turn, be shared with grid managers and suppliers. Consequently, a thorough privacy test was conducted. It

was found that three aspects of the proposed bill contain severe breaches of privacy as laid down in article 8 of the ECHR; generation and passing on of quarter-hourly measurements to grid managers, and of daily readings to grid managers and suppliers, and the compulsory use of SMs [40].

Considering these flaws, the First Chamber of Parliament blocked the bill from passing in its original form. The bill was amended to remove the obligation to install SMs, provide an option to turn off smart functionality, to require explicit consumer consent for 15-minute and daily measurements and several changes in data monitoring, storing and recording processes [35].

A cost-benefit analysis of SM in the Netherlands shows the effect of detailed reading option and turn-off option. The net present value of SMs are calculated and the effect of customer's engagement with SMs is studied. If 20% of the consumers opt for detailed reading, there will be an increase in net present value of SMs by 105 million euros. At the same time, if 20% of the consumers opt for smart turn off (in order to avoid SM privacy issues), the net present value will have a reduction of 15 million euros [41]. Therefore, SM privacy issues should be tackled not by uninstalling the system or turning it off, but by finding alternative solutions that don't compromise on the efficiency of the installed systems.

The amendment on Directive on energy efficiency in October 2012 sets detailed laws for Member states regarding metering, billing information, and access to metering and billing information. The security of the SM and data communication should be in compliance with Union data protection and privacy legislation [11].

In the wake of increasing concerns about SMs, the European Data Protection Supervisor (EDPS) published a detailed opinion regarding the roll-out of smart metering systems. Considering the risks to data protection, it has been emphasized that the smart metering will have to fully comply with the associated national legislation and relevant EU legislation regarding personal privacy. The EDPS recommends that even where time-of-use tariffs are in place, in the absence of informed consent, readings should not be done more frequently than every half an hour or hour [42].

The Dutch government is planning to achieve a minimum of 80% coverage of SMs within 2020. The customers are given a choice to opt-out of the program, and given full ownership of the data [43].

## 2.4. Protection and Mitigation

Data leakage and deliberate intrusion can happen in billing phase, operations or during other services like demand response. The regulations and directives can legally control the

operations of the SM. The technological preventive solutions are much more complicated. One approach might be to aggregate and encrypt the data being sent back and forth from the utility and SMs. However, this has to be done along with the deployment of SM; else, the cost incurred would be high [23].

Several methods were proposed by the researchers to protect the data even if the attackers gained access to it. Using Public Key Infrastructure (PKI) adapted for an SG, can mitigate some of the cyber-security threats in the SG [39][40]. Privacy-Preserving Models (PPPs) like Symmetric DC-Nets (SDC-Nets), Elliptic Curve Cryptography (ECC) and quantum cryptography can be used to convert the measurements to monetary values by multiplying it with the buying/selling price [41]. In-network aggregation in a distributed manner along with homomorphic encryption can ensure the security of the data en route [42]. Similarly, many encryption techniques are available to counteract the issues faced by the SM users. Most of these solutions are computationally intensive and require a trusted third party to encrypt [43][44].

Another method is to mask the original data by adding noise as seen in **Error! Reference source not found.** A lightweight method to implement this is to generate a random number and add this number to the measurement to be sent to the power provider [44]. Alternatively, a fault-tolerant protocol can be used, which can handle general communication failures while ensuring differential privacy with improved efficiency and reduced errors [45]. However, perturbing the system may lead to inaccurate measurements and reduce the performance of power control devices [46].

Demand Side Management (DSM) is a simple decentralized approach for scheduling the usage of domestic appliances, especially large loads. Such systems allow the shifting of schedule to fit into the most economical time. DSM is another widely studied method to avoid privacy issues related to SMs. Game Theory is an essential analytical tool used to design decentralized DSM systems based on dynamic pricing. The major drawback of traditional game theory approach is that it requires users to communicate their energy consumption patterns to other players in the power grid. Therefore, some advanced research papers propose privacy-friendly DSM systems by implementing additional data protection tools [46]–[48].

Energy storage systems like rechargeable batteries can be used to hide the information in consumption data by moderating the home load signature. The privacy aspects get improved with increasing battery sizes to a limit [49]. For an average single-family detached type house in Sweden, an ESS of capacity between 6-10 kWh can result in an almost flat power profile [50]. In Figure 2.4, a simple battery system is considered without any DG source. The power flow is shown represented as X and information flow as Y. It can be seen that the output load Y, reported by the battery to the utility company is the aggregate of the appliance load and the

battery load. The power flow is from the utility company to the battery and then to the appliances. In this setup, the battery can, either store the energy for future use or relay power directly from the utility company to the appliances. In this way, the battery can partially decouple the information flows [51].

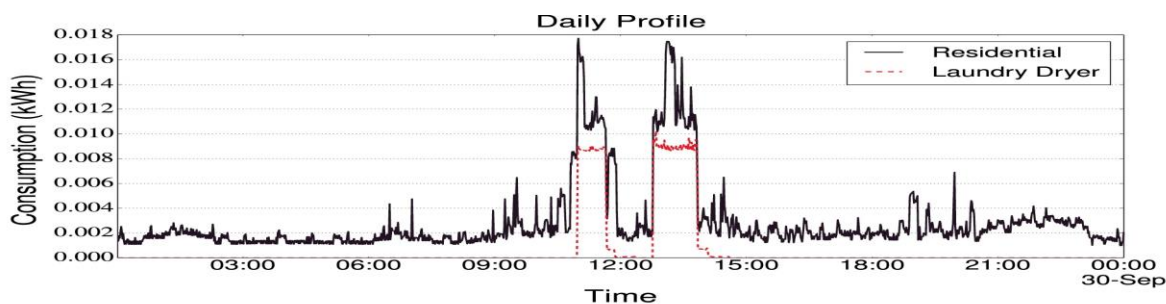

(a) Residential (black solid) and Laundry Dryer (red dashed) daily profiles with measurements at each 1 minute.

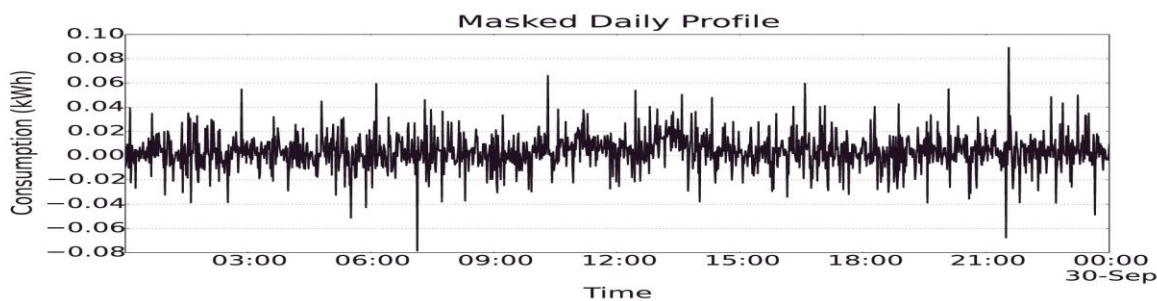

(b) Residential masked daily profile with measurements at each 1 minute.

*Figure 2.3 Masking of consumption curve using noise addition [45]*

When a renewable energy source is available in the household, ESS can serve as a battery backup and also mask the consumption curves. ESSs are beneficial to both the user, and the DSO. For the user, it optimizes the income from produced electricity, maximizes feed-in compensation and serves as battery backups. The DSO, in turn, have improved grid stability, load shifting, and grid availability. Besides, widespread DES implementation will result in a number of new business opportunities for DSOs [27].

In Sweden, as a part of progressing towards a 100% fossil-free energy system, state support is offered for the installation of photovoltaics (20% of the installation cost for private persons and 30% for businesses). Additionally, owners of PV systems with an installed capacity below 255 kW are exempted from tax payment on use of self-produced electricity. As mentioned earlier, batteries receive support of 60% of installation cost [13]. These conditions are favorable for the installation of ESS along with a renewable energy source (RES) like solar or wind power system in Swedish households. The mitigation of SM privacy, thereby, becomes an added advantage.

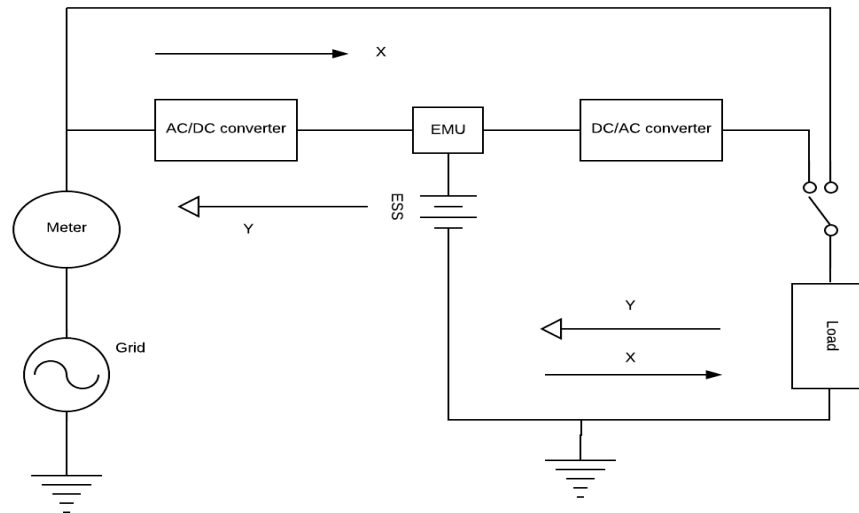

Figure 2.4 Charging and discharging of the batteries that partially decouples the information flow [51]

## 2.5. Summary

In this chapter, the advantages of using a SM is discussed along with the functionalities it can provide. Though SMs are extremely important in transitioning from the traditional grid to a smart grid architecture, the potential privacy breaches from SM data cannot be overlooked. Researchers have shown that through non-invasive techniques, it is possible to extract the appliance usage information from SMs. This has led to anti-smart meter protests in some parts of the world, resulting in lesser acceptance of smart meters.

The EU legislature strictly prohibits any use of personal data for anything other than the intended purpose of the data collection. GDPR, an EU regulation regarding data protection, has resulted in increased transparency in data processing and sharing. Though legal frameworks are in place, alternative ways of safeguarding data have been studied.

Using energy storage systems for hiding the appliance usage data is one method by which privacy invasion can be prevented. In further chapters, how an ESS can be used to mask the consumption curves can be seen.

### 3. Energy storage systems for smart meter privacy

Renewable Energy Systems (RES) are becoming increasingly popular due to its replenishing and non-polluting nature. However, these sources are intermittent and unpredictable. Before the large-scale investments in RES, the electricity market was mainly demand driven. When the share of RES increased, achieving the balance between demand and supply became difficult. RES sources cannot change the energy generation with respect to the demand. Hence, demand response (DR) became highly encouraged. Demand response refers to the changes in electricity usage made by the end-use customer in response to the change in the price of electricity over time, or to incentive payments during high load periods [52][53].

Another solution to the intermittency of RES is to introduce energy storage systems (ESS). The rapid growth of RES has triggered advanced developments in ESS, especially in battery energy storage systems (BES). An analysis by McKinsey shows that the cost of ESS are falling and could reach \$200 by 2020 from \$400 in 2016 [54]. Due to increased investments in energy storage, ESS are becoming more affordable for household consumers. ESS combined with photovoltaic (PV) panels can turn a consumer into an active prosumer who can buy and sell electricity from/to the grid depending upon the real time electricity rates. Mitigation of SM privacy issues will be an added advantage to the customers who are already interested in installing a PV-ESS system.

In the previous chapter, a brief description of how ESS can be used to mitigate smart meter privacy issues was given. In this chapter, the methodology implemented to control the ESS charging is defined. From there, an approach to determine the minimum capacity of ESS for privacy preservation is presented. It should be noted that the data used for this study is taken at an interval of 1 second. As stated in the previous chapter, SM measurements in the EU are taken at a minimum interval of 15 minutes. Hence, the resolution of the data used in the study is larger than the real SM data.

#### 3.1. Residential PV systems

Sweden has been experiencing a large decrease in PV system prices since 2010 (see Figure 3.1). The trend can be attributed to the increase in growth in energy market and decrease in PV prices in global market. With high level of competitiveness among the suppliers and development of an experienced network of installers, the system cost will continue to decrease over the next few years [4]. The decrease in the cost of PV panels combined with various incentive programs have resulted in a rising number of domestic PV installations [5].

When a distributed generation source like PV panel is installed at a location, the owner has a



choice to connect it to grid or to have it as a stand-alone system. In some countries, grid injection is restricted by the government. In Sweden, for residential applications, grid connected systems are widely used. For comparison, in 2016, the total installed power of residential PV panels connected to grid was 21.33 MW whereas off-grid installed power was 1.44 MW [5]. The off-grid systems are mainly operated in areas where grid extensions can be expensive, like islands.

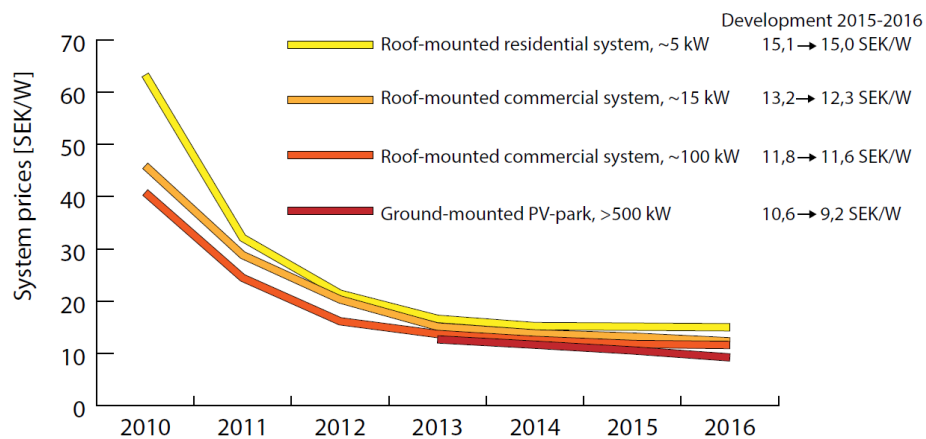

Figure 3.1 System prices of PV panels (excluding VAT) over the years. Reproduced from National Survey Report of PV Power Applications in Sweden [5]

The main challenge faced by the grid connected systems is their inadequacy during the high demand period [6]. During the peak time, the conventional power plants have to ramp up their production to meet the demand. With the introduction of RES to the grid, the electric systems need to have high operational flexibility. The California Independent System Operator (CAISO) demonstrated the effect of RES in electricity demand through plotting the net load (actual demand – RES production) with time (see Figure 3.2). This chart, called as duck curve, shows how the electricity demand is likely to evolve through years with the increase in DG sources [7]. The data for the curve is from California. In Nordics, the consumption of electricity will be higher at night due to cold winters.

A solution to the duck curve demand pattern is to couple the DG sources with energy storage systems. Storing the energy during the low consumption periods can help to minimize the peak during the high load periods. Unlike stand-alone systems, grid connected systems need not have large capacities to cover for long periods of low PV production. Hence, the grid connected PV panels require only a small storage capacity compared to stand-alone systems. From an economic point of view also, the users with PV systems benefit the maximum when they use the energy generated from the PV rather than injecting to the grid [55]. This can be done by having an ESS or by adjusting their demand to the day time.

For a grid-connected user, the SM measures the bidirectional flow of electricity. The price of

the electricity is determined by the electricity buying price and selling price. The effect PV production plays on consumption curves is discussed in the next section.

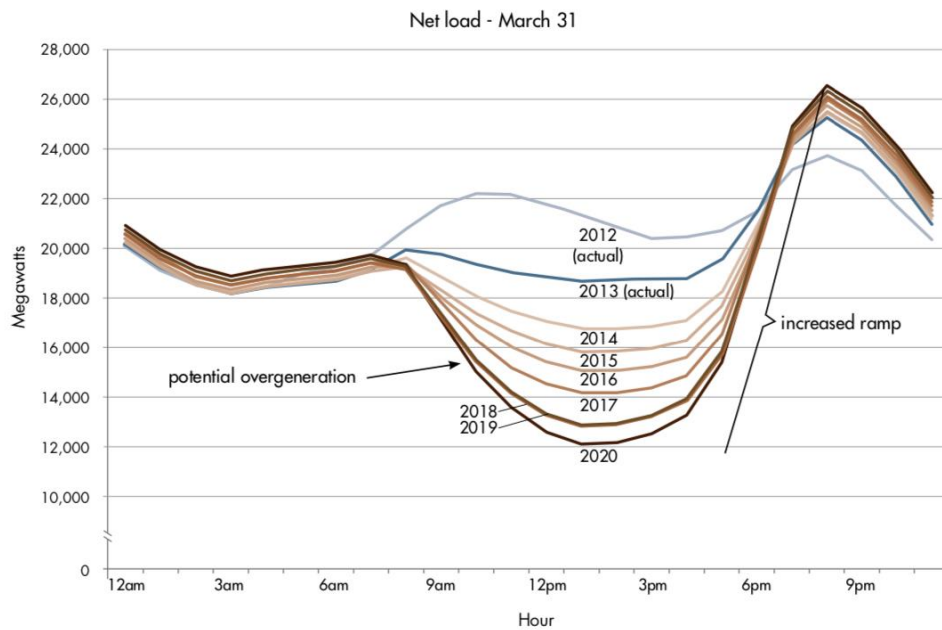

Figure 3.2 The duck curve. Reproduced from CAISO [7]

### 3.2. Effect of PV production on consumption curves

To understand the role of PV generation in SM data study, a simple case of a household with a PV panel is considered as shown in Figure 3.3.

In the absence of an energy storage system, the solar panels are directly connected to the load ( $P_{load}$ ) through a converter, parallel to the grid connection (see Figure 3). Hence, the instantaneous power fed from the electricity grid to the household ( $P_{grid}$ ) is

$$P_{grid}(t) = P_{PV}(t) - P_{load}(t) \quad (2.1)$$

where  $P_{PV}(t)$  is the instantaneous power generated by the solar panel.

As the meter is connected in the incoming line from the grid, power as seen by the SM ( $P_{SM}$ ) is  $P_{grid}(t)$ . The power flow from the grid to the household is represented as positive and the injections to the grid is shown as negative.

Figure 3.4 shows the power consumption and generation curves of a household with an average daily consumption of 8.3 kWh and a solar panel of 2.88 kW power rating. In Figure 3.4a, it is assumed that the user has a bidirectional meter which feeds power back to the grid. The black curve represents the power as seen by the SM. The solar production peaks between



10 am and 6 pm. During this period, the power produced is higher than the power consumed by the household. Hence, the excess energy is fed back to the grid. In Figure 3.4b, it is assumed that the user is not injecting power back to the grid. This may be due to the restrictions imposed by the government or due to the lack of incentives in doing so. In this case, once the power generated by the solar exceeds the power consumed by the household, the power bought from the grid becomes zero.

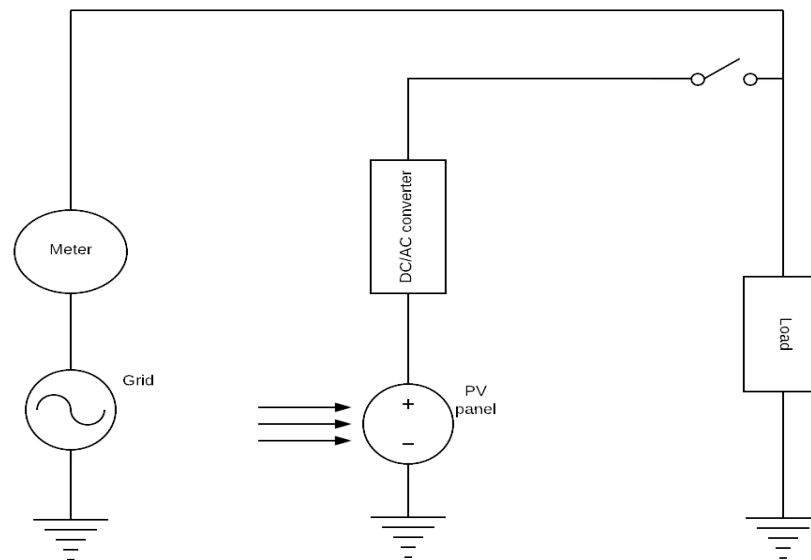

*Figure 3.3 Household with PV panels but without ESS*

On the studied day, the total household consumption is 8.94 kWh and the total solar energy potential for the panel is 15.21 kWh. The user in case b, injects the excess energy back to the grid. However, in the absence of an ESS and grid injection, the user in case a, uses only a part of solar energy (during the peak production time) and loses the opportunity to produce his full installed PV capacity.

In both the cases, the SM data is altered only when the solar power is available. The peak consumption outside the solar production period is still visible in the SM data. In most of the households, the peak consumption occurs in the morning (6 – 9 am) and in the evening (6 -9 pm) [56]. Using only PV panels, these patterns remain revealed. Therefore, a method to mask the consumption curve through addition of an ESS is investigated.

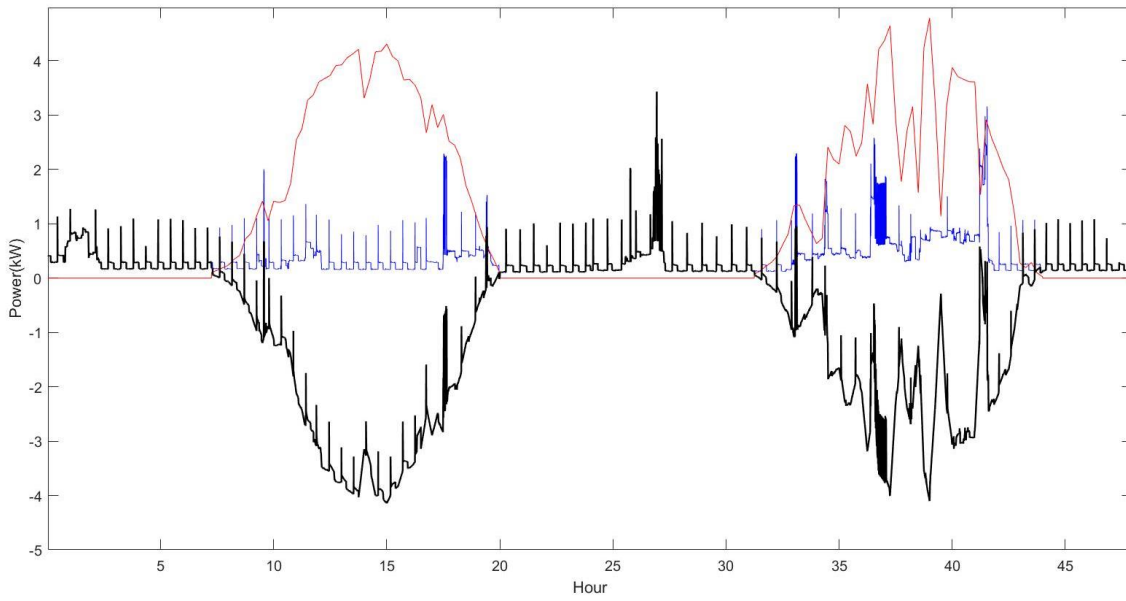

a. The user injects excess power back to the grid

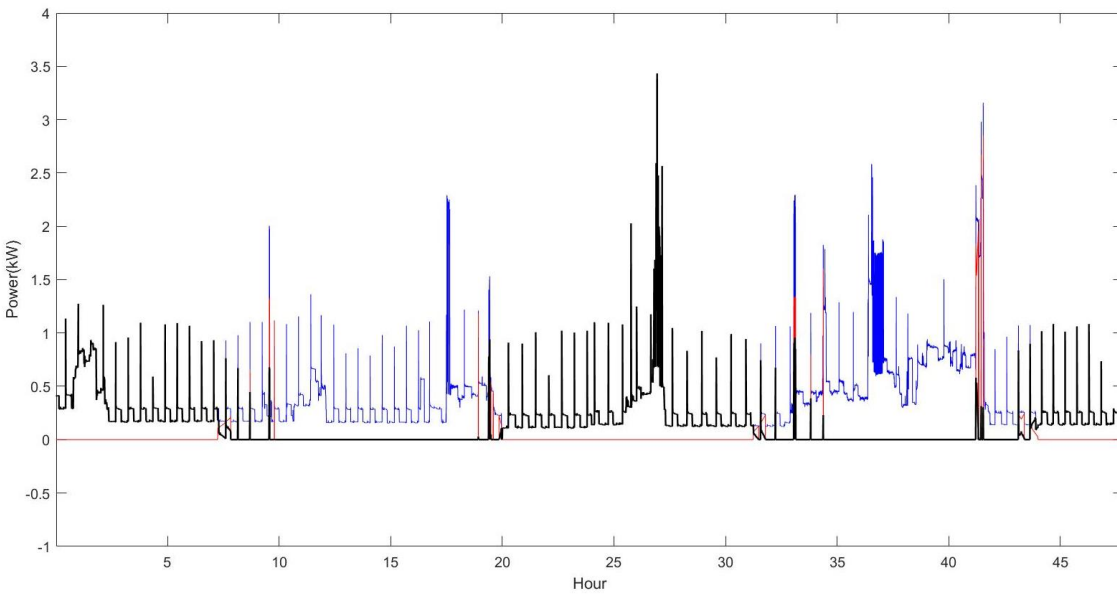

b. The user decides not to inject power to the grid

Figure 3.4 The consumption, generation and grid supplied power of a household with PV in absence of an ESS

### 3.3. Algorithm for ESS charging and discharging

The proposed arrangement for using an ESS alongside the PV panels is given in Figure 3.5. The AC loads are connected to the ESS as well as to the grid through a transfer switch. The switch will ensure that the loads can be connected to the grid if ESS has some technical issues. The ESS is connected to the solar panels and the grid (through a converter). Under normal operating conditions, the loads will be charged through the ESS. In this case, the power bought from the grid ( $P_{grid}$ ) will be given by

$$P_{grid}(t) = P_{PV}(t) - P_{ESS}(t) - P_{load}(t) \quad (2.2)$$

where  $P_{ESS}$  is the power transferred to/from the ESS,  $P_{PV}(t)$  is the power generated by the PV panels and  $P_{load}$  is the power consumed by the loads at time  $t$ .

It is postulated that for showing least information as possible,  $P_{grid}(t)$  has to be a constant value. Thus, a value  $P_{mean}$  is defined as the average net consumption of the household.

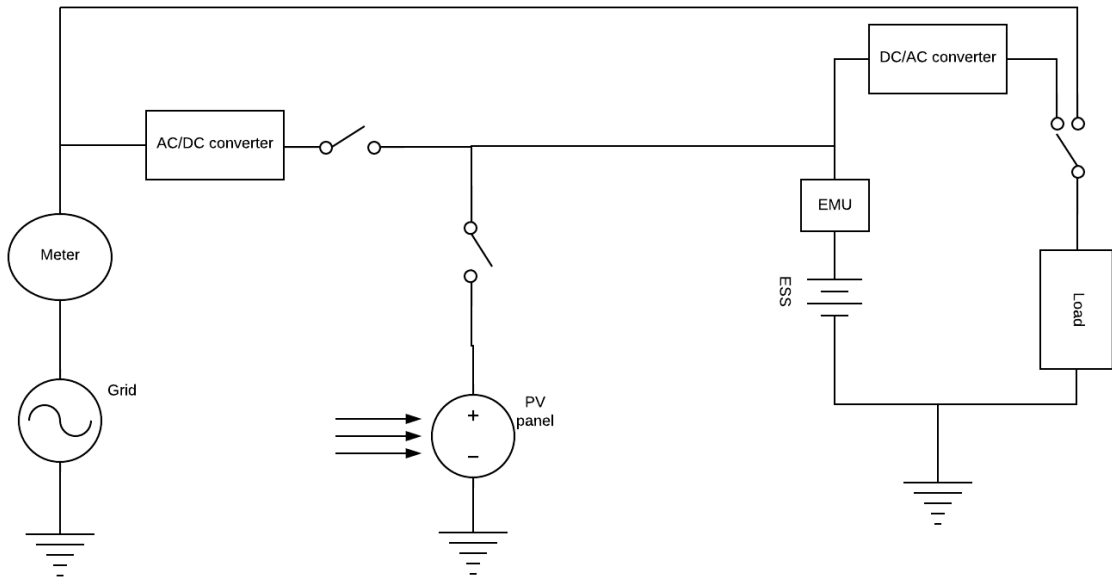

Figure 3.5 Household with PV panels and an ESS

We assume that the power bought from the grid equals to  $P_{mean}$ .

$$P_{mean}(kW) = \frac{\text{average daily consumption (kWh)} - \text{average solar energy production}}{24} \quad (2.3)$$

$$P_{grid}(t) = P_{mean} \quad (2.4)$$

The net load as seen by the SM is

$$P_{SM}(t) = P_{mean} \quad (2.5)$$

Therefore, the power as seen by the SM will remain a constant. All the energy flows are managed by the energy management unit (EMU). EMU is programmed such that the above condition is fulfilled. If the energy level of the ESS ( $E_{ESS}$ ) drops below zero, then the EMU algorithm should increase the power by small increments such that the energy level is maintained above the lower threshold.

When the ESS is fully charged, the grid is disconnected and the loads are fed by the ESS. Hence, the power registered by the SM is also zero.

$$P_{SM}(t) = P_{grid}(t) = 0 \quad (2.6)$$

and

$$P_{ESS}(t) = -P_{load}(t) \quad (2.7)$$

The amount of energy in ESS between  $t_1$  and  $t_2$  is given by

$$E_{ESS}(t_1) = \int_{t_1}^{t_2} P_{ESS}(t) dt \quad (2.8)$$

The power generated by the solar panels cannot be stored in the battery, if the battery reaches full capacity ( $E_{cap}$ ) i.e, state of charge (SOC) of the ESS = 100%<sup>2</sup>. To ensure maximum storage of PV power, an upper threshold ESS capacity level ( $E_{upper}$ ) is defined, above which the ESS stops charging from the grid and start feeding the load instead. Similar to the case of the household with no ESS, two different cases can be defined at this point. 1. The user only wants to store the energy his/her ESS can store and uses the additional energy generated for auxiliary activities like heating. 2. The user decides to inject power back to the grid.

In the first case, when the ESS energy level ( $E_{ESS}$ ) is between  $E_{upper}$  and  $E_{cap}$ , i.e.  $E_{upper} \leq E_{ESS} \leq E_{cap}$ , the power as seen by the SM remains zero (grid is disconnected), but  $P_{ESS}$  becomes

$$P_{ESS}(t) = P_{PV}(t) - P_{load}(t) \quad (2.9)$$

---

<sup>2</sup> State of charge (SOC) of an energy storage is the level of charge of an ESS relative to its capacity. SOC = 0% means battery is empty and SOC = 100% means the battery is full.

In the second case,  $P_{ESS}$  when the ESS energy level ( $E_{ESS}$ ) is between  $E_{upper}$  and  $E_{cap}$  is given by

$$P_{ESS}(t) = P_{PV}(t) - P_{load}(t) - P_{grid}(t) \quad (2.10)$$

where  $P_{grid}$  is the power fed back to the grid.

From equation 2.5, the power as registered by the SM is

$$P_{SM}(t) = -P_{PV}(t) + P_{ESS}(t) + P_{load}(t) \quad (2.11)$$

$$P_{SM}(t) = -P_{PV}(t) + P_{PV}(t) - P_{load}(t) - P_{grid}(t) + P_{load}(t) = -P_{grid} \quad (2.12)$$

In both the cases, when the ESS energy levels drop below a lower threshold ( $E_{lower}$ ), it stops discharging and start charging again.

The equations described above is converted to an algorithm as depicted in Figure 3.7. The curves of consumption, generation, power bought from the grid and the ESS energy levels of the first case and the second case are given in Figure 3.6a and Figure 3.6b respectively. Both cases are simulated with an ESS capacity of 5 kWh, charged from empty. The upper threshold is set at 4 kWh. The energy level reaches the upper threshold at around 12 pm and starts discharging. The difference between the two cases can be seen after this discharge. The ESS in the first case ( $ESS_1$ ) has a faster discharge rate due to the additional grid injection than the ESS in the second case ( $ESS_2$ ). The former gets back online before the peak consumption around 8 pm while the latter is able to supply the consumption on its own.

From Figure 3.8 , it can be seen that the power from/to the grid is a piecewise constant that depends on the ESS energy levels and PV production rather than on the household consumption. The charging and discharging of the ESS can be programmed in different ways. A user can buy/sell power from/to the grid for economic profits or for better demand-response. Another user might charge the ESS exclusively from the solar panel and not from the grid. The approach that is used here is very straightforward and basic. The ESS charges when the energy levels are low and discharges when it reaches the capacity.

Studies have shown that the batteries of electric vehicles (EVs) can be used for peak shaving in vehicle-to-grid (V2G) systems [57]. Though EVs have significant battery capacities (e.g. in 2019 the capacities of some models are: Nissan Leaf – 30 kWh, Tesla S- 75 kWh, BMW i3 – 42 kWh), masking-the-clock availability [58].

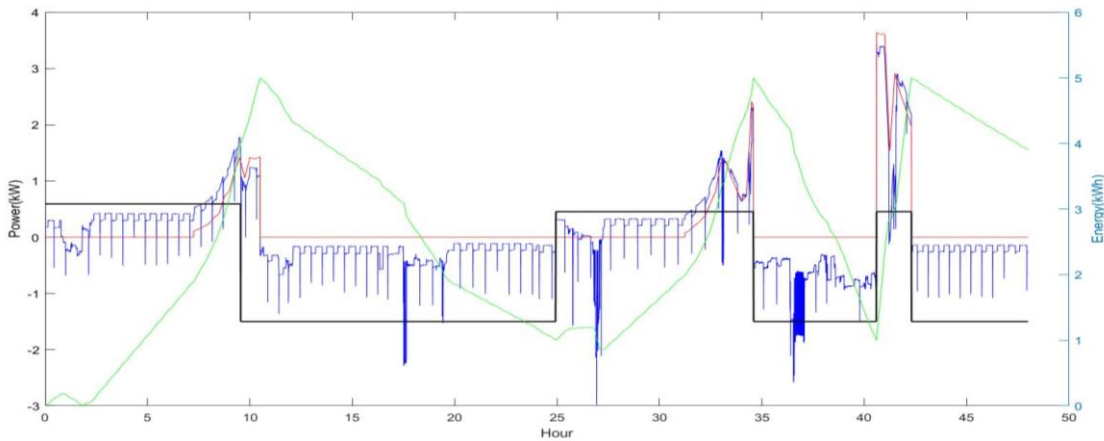

a) The user injects power back to the grid once the ESS energy level reaches the upper threshold.

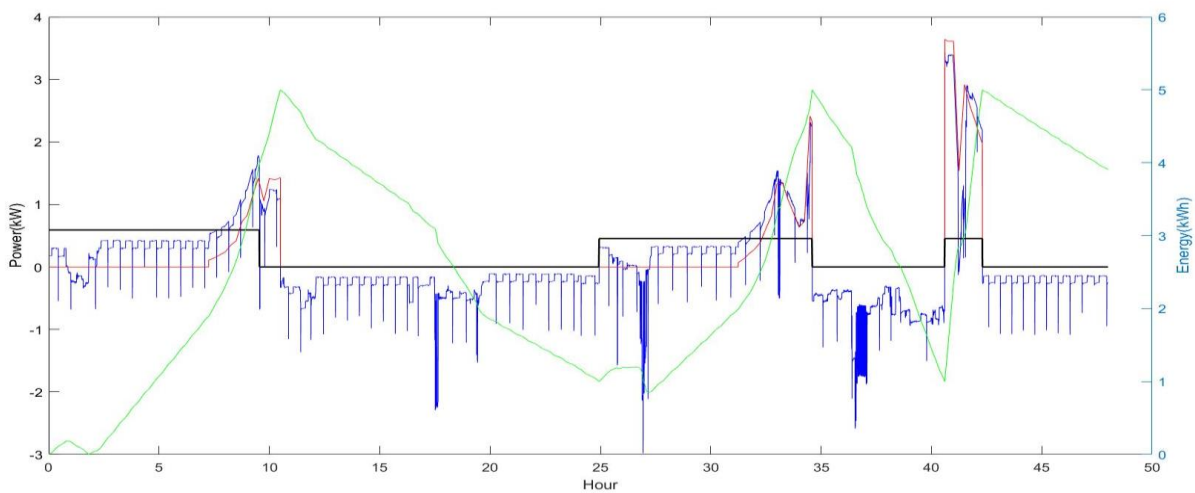

b) The user does not inject power to the grid, but stores the energy for his/her own peak consumption

Figure 3.6 The consumption, generation and grid supplied power of a household with PV along with an ESS. The green curve represents the energy level of the ESS during the day.

### 3.4. Sizing ESS for SM data privacy

The ESS capacity is a crucial factor in SM data privacy preservation. The effect of increasing the size of the ESS can be seen in Figure 8. Even though the power bought from the grid does not reflect the actual consumption curves in any of the cases, the frequency of charging and discharging cycles vary widely. The ESS with capacity of 2.5 kWh shows recurrent charging and discharging cycles over the period of 48 hours whereas an ESS capacity of 15 kWh acts as an off-grid power source after the initial charging. The latter is able to sustain the charge

over long periods as long as the solar energy production is greater than the household consumption.

The life of energy storage systems is given in terms of complete cycles with a specific depth of discharge (DoD). The average life of a Lithium-ion battery is about 3500 cycles [59]. Having multiple incomplete charge-discharge cycles in a single day might affect the life of the ESS. Although smaller capacities of ESS (less than 25% of average household consumption) can create flat consumption profiles, it is better to choose a minimum capacity that will not result in more than one cycle per day.

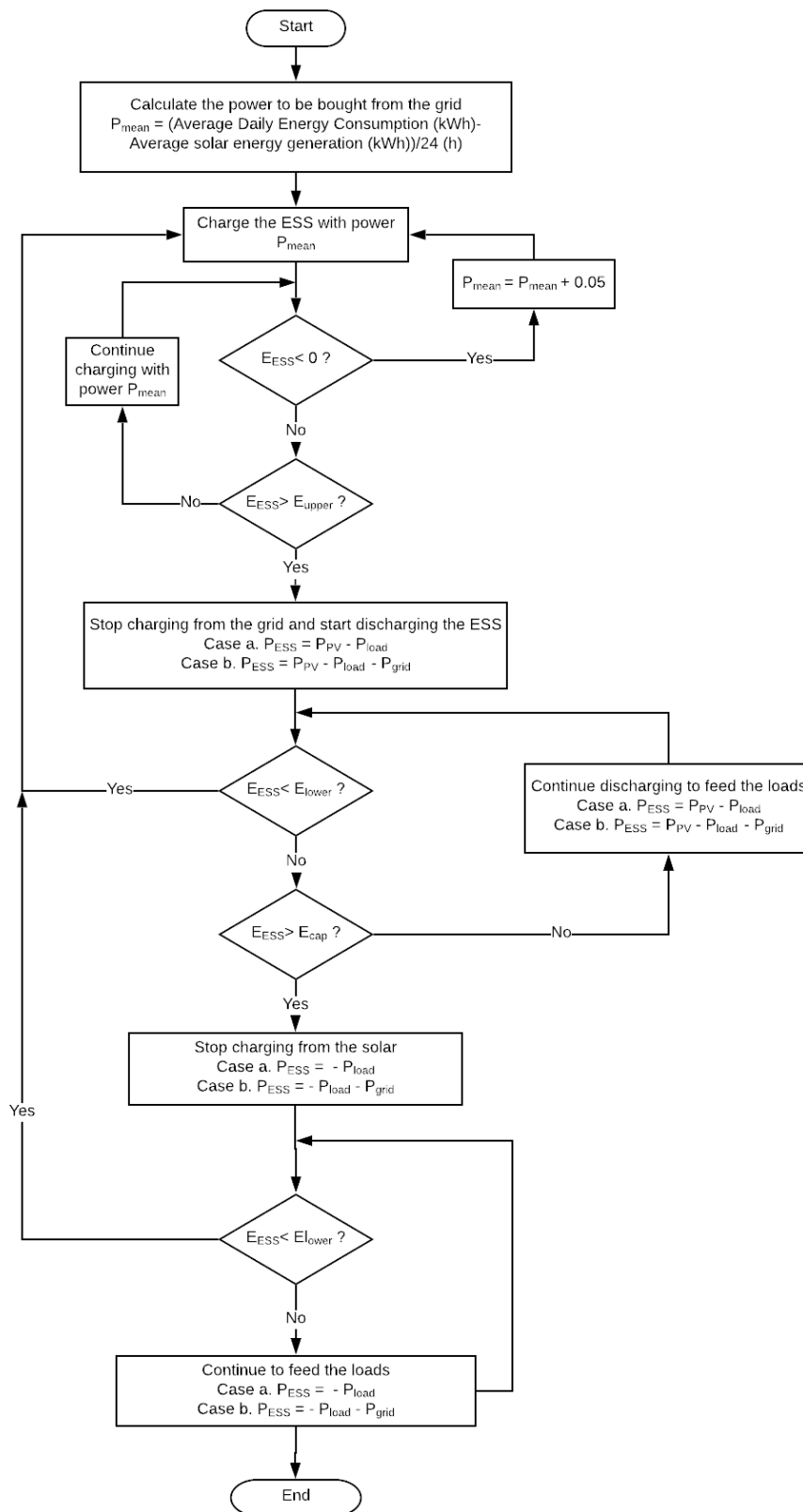
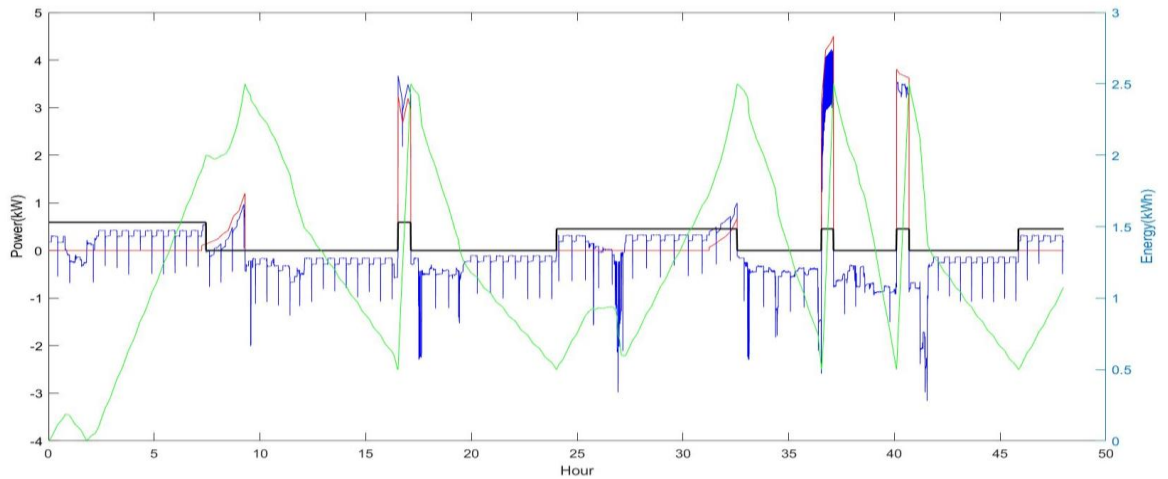
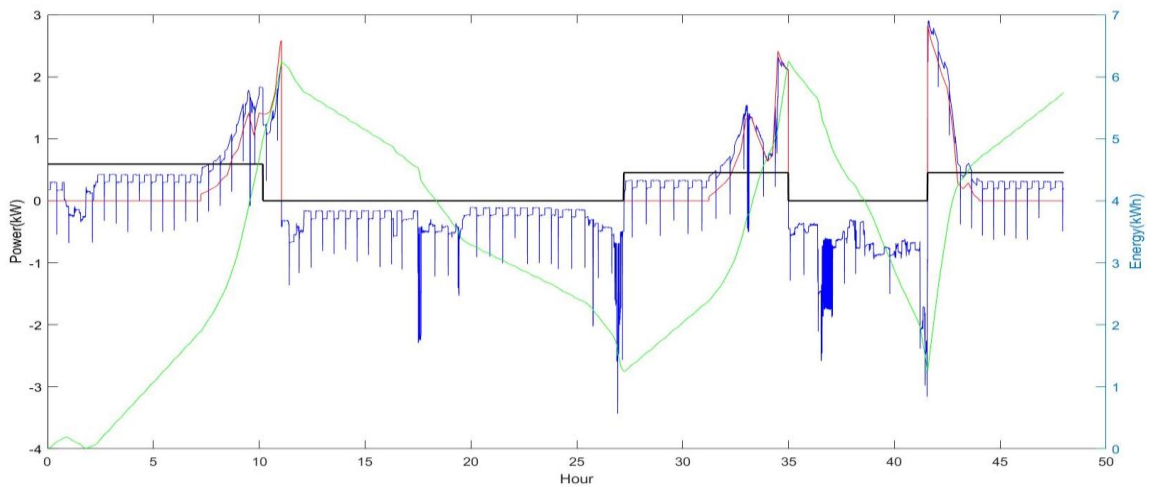

Figure 3.7 The algorithm implemented for charging and discharging the ESS





a) ESS capacity = 2.5 kWh



b) ESS capacity = 5 kWh

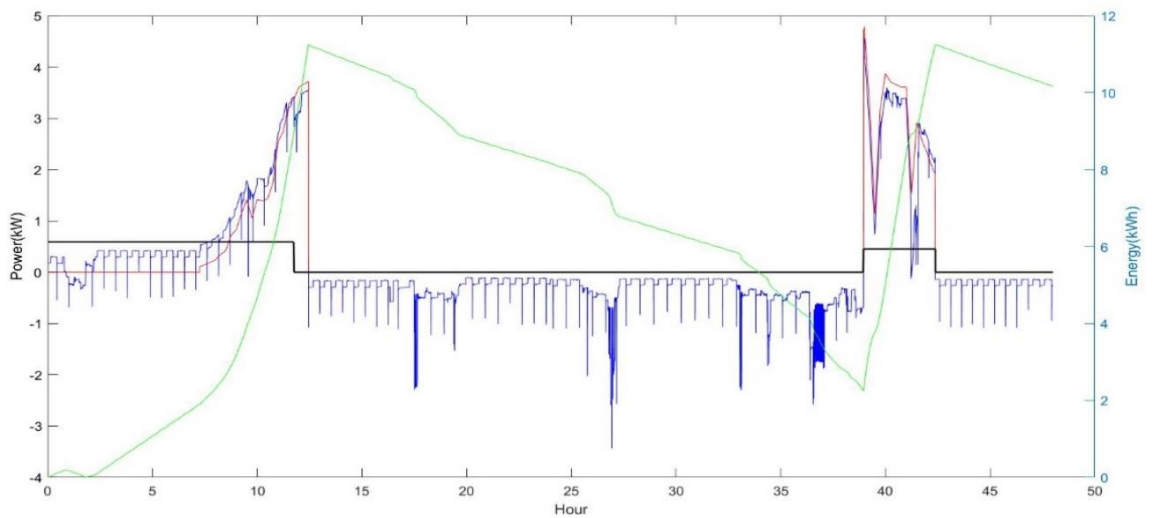

c) ESS capacity = 10 kWh

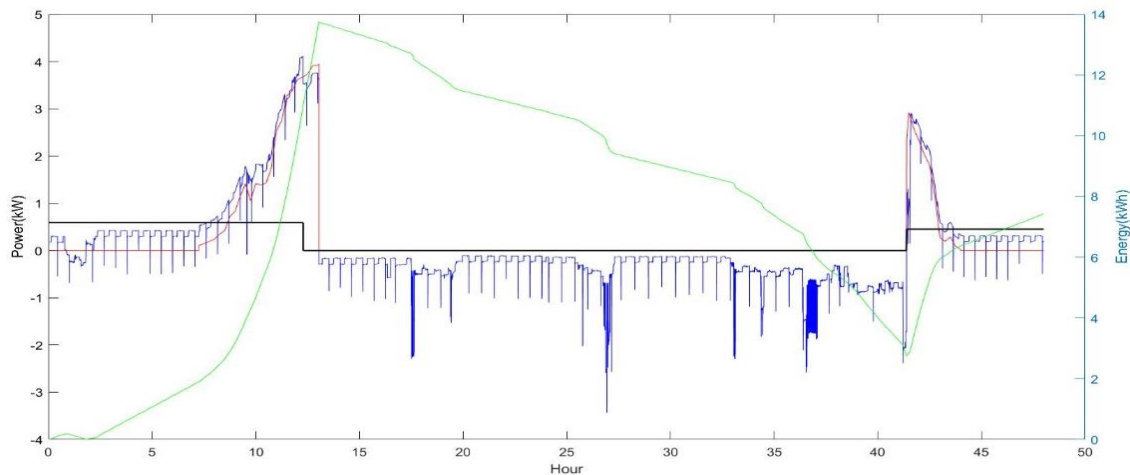

d) ESS capacity = 15 kWh

Figure 3.8 The effect of increasing the ESS capacity on charging cycles during a 48-hour span. The considered user does not sell energy to the grid

There are different ways in which the ESS can be sized for privacy preservation. As mentioned above, increasing the capacity of ESS can decrease the grid dependency but can also result in increased cost. For example, the average cost of Lithium-ion battery energy storage system is between 844 €/kWh and that of a Lead-acid battery is 171 €/kWh<sup>3</sup> [60].

In order to maintain a flat profile without incurring large costs, the minimum capacity required for an ESS to mask the features of the consumption curve is investigated. The consumption patterns of four different households are used for the study. The average daily household consumptions of the houses were 8.88 kW, 8.75 kW, 7.35 kW and 8.23 kW.

The solar power generation data is taken from two panels of rating 2.88 kW and 5.28 kW [61]. The average energy generated by the panels on a sunny day are 16.26 kWh and 30.65 kWh respectively. As solar power generation is extremely dependent upon the weather, the PV generation under different weather conditions (sunny, cloudy, mostly cloudy and rainy days) are studied.

The ESS capacity is reliant on the pattern of household consumption. For example, if a user has a uniform consumption throughout the day, the ESS capacity required to mask his consumption profile will be less. At the same time, if a user has a peak consumption when the

<sup>3</sup> Energy capacity costs only. The power conversion system costs, and operation and maintenance costs are not included

ESS energy level is low, the ESS will buy more power from the grid to compensate for the peak, resulting in a spike.

To account for the dependency of the capacity on the user consumption patterns, different combinations of available patterns are simulated. Similarly, the weather conditions were also randomly selected from a list of all available combinations. Starting from a very small value of ESS capacity, the program automatically incremented the capacity till no anomalies (spikes or troughs) are detected in the consumption as depicted in Figure 3.7. For a single household, under a given weather conditions, 15 different patterns were analysed and the capacity of ESS required to maintain the flat profile is determined. Aggregating these data, an equation for the minimum capacity of ESS required to maintain a flat profile is formulated in terms of average household consumption and average solar energy production.

The different cases that are studied from the obtained data are as following.

- The effect of grid injection on the ESS capacity requirement for the same conditions
- The change in ESS capacity requirement with respect to the weather conditions for the same household

### 3.5. Results

The effect of ESS charging is studied over a period of four days. For every household, there is a minimum of four days data available. From this data, the program randomly selects four days and run the simulation. For example, one combination might be day 1- day 3- day 2 - day 5 whereas another combination might be day 3- day3- day3- day3. The mean and standard deviation of the available data from different households are given in Table 3.1.

*Table 3.1 Mean and variance of the average daily consumption of the households*

Household	Household 1	Household 2	Household 3	Household 4	Combination of all households
<b>Mean (kWh)</b>	8.879	8.747	7.348	8.231	30.976
<b>Standard Deviation</b>	0.763	1.399	1.711	1.455	2.9389

Two cases are considered for the simulation. Case 1) the user buys power from grid but does not inject back to the grid. The energy produced from the solar panels as well as the stored

energy is used only for self – consumption. Case b) the user has a bidirectional flow of power from/to the grid. For simplicity, the power fed back to the grid is assumed to be controlled by the EMU and remains a constant. In the simulations, it is set that when  $SOC \geq 0.8$ , the ESS starts to inject a constant power of 1.5 kW back to the grid. Load management and feed-in tariffs are not considered for this simulation.

Two cases are considered for the simulation. Case 1) the user buys power from grid but does not inject back to the grid. The energy produced from the solar panels as well as the stored energy is used only for self – consumption. Case b) the user has a bidirectional flow of power from/to the grid. For simplicity, the power fed back to the grid is assumed to be controlled by the EMU and remains a constant. In the simulations, it is set that when  $SOC \geq 0.8$ , the ESS starts to inject a constant power of 1.5 kW (a random value for simulation) back to the grid. Load management and feed-in tariffs are not considered for this simulation.

The minimum ESS capacity is determined by the piecewise linearity and the number of charging cycles per day. The power flows from/to the grid remains a constant over a period. The charging cycles are restricted to a maximum of one per day. The ESS capacity requirement for different combinations are used to formulate a minimum capacity requirement for a given household consumption and solar energy production. The surface plots obtained are given in Figure 3.9.

The ESS capacity requirement ( $ESS_{cap}$ ) for a household with no grid injection (case 1) is obtained as

$$ESS_{cap} = 1.123 + 0.402E_{cons} + 0.05841E_{solar} + 0.001339E_{cons}^2 - 0.003586E_{cons}E_{solar} - 0.001126E_{solar}^2 \quad (2.13)$$

where  $E_{cons}$  is the typical daily household consumption and  $E_{solar}$  is the average solar energy production. For example, if a household with a typical consumption of 8 kWh has a solar panel with an annual average production of 8 kWh/day, then the minimum ESS capacity required by the household to preserve privacy will be 4.7662 kWh. It is worth mentioning that, without grid injection, for the same household consumption, the minimum ESS capacity required decreases slightly for increasing solar production.

The ESS capacity requirement for a household that injects a constant power of 1.5 kW to the grid when  $SOC \geq 0.8$  is

$$ESS_{cap} = 2.713 + 0.397E_{cons} + 0.2448E_{solar} + 0.0004763E_{cons}^2 - 0.002765E_{cons}E_{solar} - 0.00007272E_{solar}^2 \quad (2.14)$$

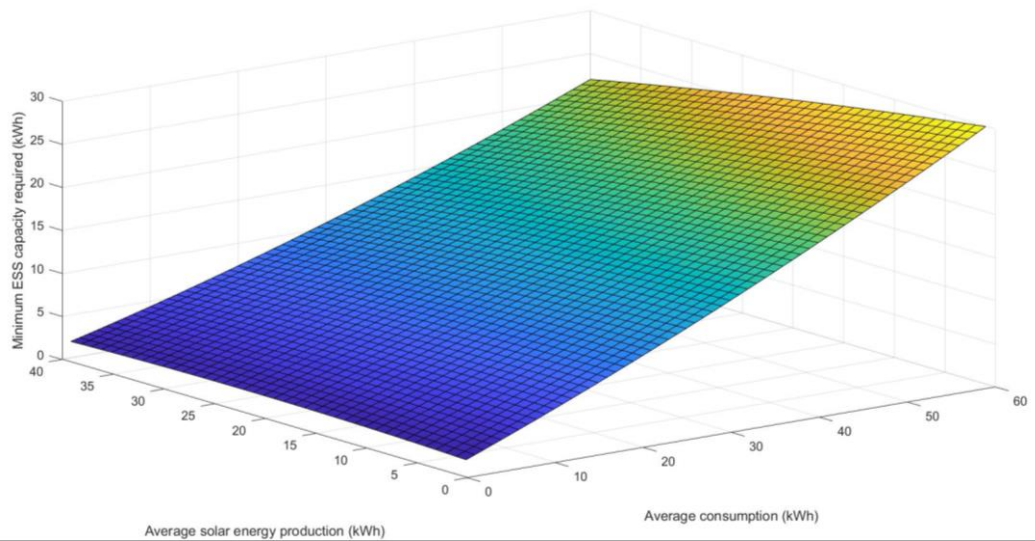

a. The user does not inject power to the grid

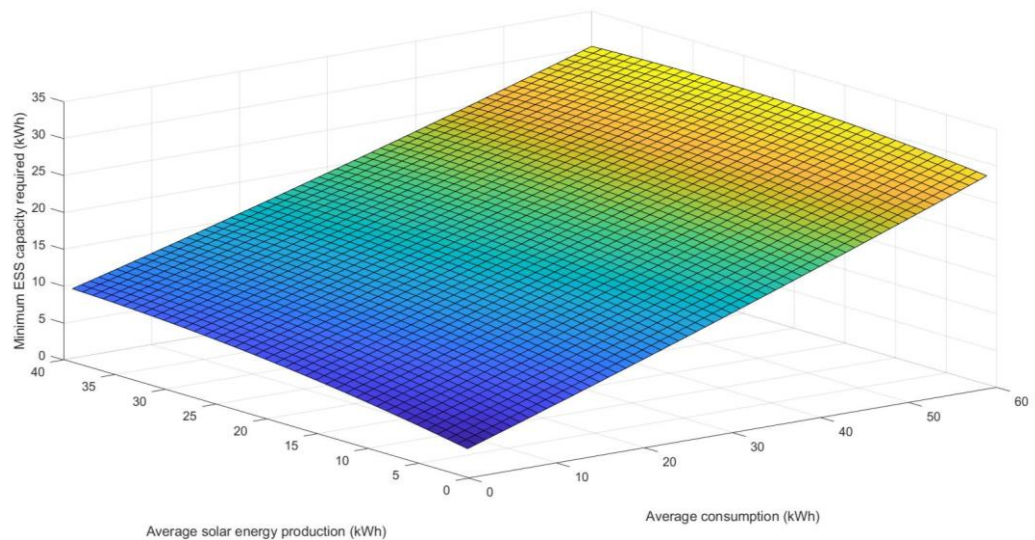

b. The user injects a constant power of 1.5kW to the grid when SOC= 0.8

Figure 3.9 Surface plot of minimum ESS capacity requirement

In contrast to case 1, the minimum ESS capacity increases with increasing solar energy production when the user injects excess power back to the grid. The capacity requirement for case 2 can be seen as slightly higher than that of case 1. This is consistent with the observations made in the earlier part of the chapter (Figure 7). For the same capacity of ESS, when power is injected back to the grid, the SOC drops rapidly than in the case of self-consumption. This will result in large number of charging cycles per day which, as said earlier,

is punished. Hence, the capacity required for the grid injection will be higher than the case without grid injection.

It is noteworthy that in case 1, the minimum ESS capacity required does not go higher than 50% of the household consumption in any cases. But in case 2, ESS capacity becomes 90-110% of the household consumption when the solar energy production is much larger than the household consumption. For example, taking the household with 8kWh consumption, when the solar production is 2 kWh, the ESS capacity required is 6.25 kWh. When the household has a solar production of 16 kWh, the ESS capacity is 12.5 kWh.

### 3.6. Summary

PV production alone cannot mask the household consumption patterns as it is limited only to a specific time of the day. Without the use of an ESS, the only available way for a user to produce his full installed capacity is to inject the power back to the grid. But even in this case, it cannot be guaranteed that the consumption profiles remain hidden from third parties. As postulated, a piecewise linear power profile can result in minimum leakage of information. An ESS can achieve this along with high utilization of PV produced energy. There are different ways in which an EMU can be programmed to control the ESS, which depends on the priorities of the user.

In this chapter, a simple method to achieve a piecewise linearity in the power profile is presented. Compared to other SM data leakage prevention methods, adding an ESS to the household offers many other advantages. Unlike data anonymization and encryption, even central data hub will not be able to distinguish the sensitive information from the received consumption profile. Only if EMU is hacked or accessed, it will be possible to distinguish the consumption data from the grid usage data. Usage of ESS does not interfere with billing accuracy as the power recorded by the SM is the actual power taken from the grid (by the appliances and the ESS). Moreover, load flattening is an added advantage to the grid. With the decreasing cost of ESS, there is a huge potential in developing applications that can be offered as additional services. SM privacy preservation can be one of them.



## 4. Public perceptions regarding smart meter privacy issues

In Chapter 1, the legislative developments that led to the introduction of SMs across the EU are discussed. Although the EU recommended the use of SMs, it was up to the national governments to make the final decision and establish the SM common standards. The response of the public towards the smart meter roll-out differs from place to place. In the UK, smart meters will be rolled out as a standard across the country by the end of 2020, but there is no obligation on consumers to install a SM. The Department of Energy and Climate imposed a legal obligation on energy suppliers to take all reasonable steps to install SMs in all homes [62], [63]. Figure 4.1 shows the share of SMs installed in domestic sites in the UK as of March 2019. Only 26% of the total domestic sites have SMs installed. 2% of the meters are smart-type. Smart-type meter refers to the meters that do not have the full functionalities of a SM which were installed during the early phase of SM roll-out. These meters also have to be replaced by the SMs [63].

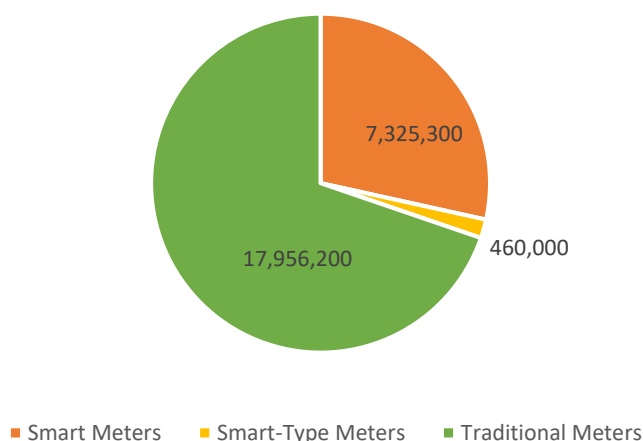

Figure 4.1 Domestic Electricity Meters in UK (31 March 2019). Reproduced from Smart Meter Statistics Quarterly Report -BEIS [63]

There are different reasons for the large share of traditional meters compared to SMs. Some of the main observations were: the roll-out started later and slower than expected, the roll-out was accelerated without making an economic assessment, cost of the program has increased more than forecasted. However, one of the key factors behind the lagging installation is the lack of awareness among the consumers. According to a survey by the Department of Energy and Climate, 74% of consumers with SMs are satisfied with them, and 48% of the consumers say that they would like to receive one in the next six months. But in practice, energy suppliers find it difficult to arrange installations with the customers because even the interested people

treat it as a relatively low priority [62].

UK smart meter roll-out is an excellent example for understanding the importance of public perceptions regarding advanced technologies. On one side, marketing programs like 'Campaign for a Smarter Britain' are trying to increase the acceptance of SMs among the consumers, but on the other side, there is a multitude of webpages spreading false claims about SMs [64]. A claim that has gained popularity in the UK as well as in some parts of the US is about the potential health hazard of the SMs. The protesters claim that even the low power radio-frequency (RF) radiation level of SMs can lead to calcium ion damage in the cells, melatonin disruption, blood-brain-barrier leakage and DNA damage [65]. Although studies done specifically on smart meters show that the RF exposure levels from SMs are far below all major international radiation exposure limits, people are worried about radiation exposure [66].

The elevated importance given to health concerns can be attributed to risk amplification. Risk amplification is defined as the process by which certain hazards and events that experts assess as relatively low risk can become a particular focus of concern and socio-political activity within a society. There is also risk attenuation where experts judge a hazard as serious but get comparatively less attention from society (e.g., smoking) [67].

Thus, public perception is an essential factor that affects the success of a technology. So far, no case of SM privacy issues has been reported in Sweden. While it is recommended that the people be aware of SM privacy issues, the concerns that are raised should be legitimate. Essentially, consumers should be in a position to take informed decisions. In this chapter, the importance of public perception of technology is discussed with a focus on RES and ESS.

## 4.1. Public acceptance of RES

*"Fish may die or human beings; drinking water or swimming in rivers or lakes may cause diseases; we may run out of oil; the global temperature may rise or fall; all these effects will not cause any societal effects unless society communicates about it. Society is sensitive to the natural environment, but it operates as a closed system. Society observes nature and environment through communication. Communicating meaning is the only means for initiating responses: therefore, it can regulate communication only by other forms of communication. In essence, it is society which poses a threat to its survival, not the environment."*

- Niklas Luhmann, translated by Ortwin Renn [68]

The policies and regulations encouraging the use of renewable energy or non-fossil fuel sources have increased over the last two decades. The success of a policy depends on how people react to it. A study on the public perception of global warming in the US shows that



citizens are supportive of national and international initiatives against global warming as long as these initiatives do not demand a significant change in their lifestyle [69].

Large projects like nuclear power plants, hydro-power dams have always been sources of political, and social conflicts. After the Chernobyl disaster, the public became unsupportive of nuclear power plants and all nuclear expansion plans were halted [70][71]. Recently, wind power projects face high resistance from the public owing to the large size, noise, and visual obstruction.

Various opinion polls suggest that the public acceptance of renewable energy is very high. This has led the policymakers and researchers to believe that social acceptance will not be an issue. But the problem with general acceptance is that people support renewable energy as long as it is not in their backyard. "Not in my backyard" (NIMBY) is a cultural term characterizing the opposition by residents to a proposed development in their neighborhood while not objecting to similar developments elsewhere. In the case of microgeneration, public acceptance is even more critical as it requires active consent and participation from homeowners. Studies on large projects show that institutional factors also play a prominent role in shaping the opinions of people [72], [73].

Understanding the preferences of people from surveys is a complex procedure. According to Sagoff, people have two different preference orderings: their private preferences that reflect how goods affect their personal utility and their public preferences that reflect moral values about what people think is right for the society. In this context, people base their decisions on right or wrong and not what they would prefer as private individuals [74], [75].

In Sweden, many wind-power projects had faced high levels of opposition from the public. Earlier studies show a high percentage of acceptance for future wind projects. Despite these results, many wind energy projects failed to clear the planning stage [76]. If the public has to accept new technology, there should be a perceived need. In Denmark, the primary motivation behind the large-scale installation of wind turbines was the perceived need. A study on wind power in Denmark and Sweden shows the difference in the starting climate in these countries. In Sweden, in 1988, electricity prices were three times lower than that of Denmark due to large hydro-power and nuclear power [77]. Denmark wanted to be self-sufficient with zero dependencies on nuclear energy. Therefore, public acceptance of wind energy was higher in Denmark compared to Sweden.

Similarly, the results of a SM privacy survey will vary from country to country. In countries like the UK and Germany, where SM privacy issues have been a topic of concern, the perceived need for mitigation methods may be higher.

## 4.2. Surveys for understanding public perception

This part of the study involves understanding the perception of people about the SM privacy issue and how much are they willing to pay for such a system. The earliest form of the survey might be a census, where the governments methodically collected information such as birth rate and death rate to track the population. Later, surveys started to be widely used in different areas to understand the needs, preferences, and opinions of the public. Opinion polls of people are an essential source of data for politicians to prepare their election propagandas [78].

With high diffusion of the internet, now it is even possible to get opinion polls by analyzing the sentiments behind the texts. Studies have yielded almost 80% correlation between sentiments analysis of texts from Twitter (a microblogging site) and opinion poll results [69]. A quick keyword search on Twitter for smart meters (smart elmätare in Swedish) shows that the concerns expressed regarding SMs in Sweden are very low [79]. This is in contrast to the trends in the UK, where there are multiple accounts dedicated to the topic 'stop smart meters' [80]. This observation is in agreement with the low acceptance of SMs in the UK, as mentioned earlier in the introduction.

There are different methods employed to conduct a research survey. Postal questionnaires/ email questionnaires have response rate less than 20% [81]. Thus, to ensure a wide demographic profile and minimum respondents, a large sample of people is required. Face to face interviews involve researcher going directly to the respondents in the street or at their homes or workplaces. The response rate is often higher than the postal questionnaires, but it is a time-consuming method. Telephone interviews are also two-way interaction between the respondent and the researcher, which is quicker and cheaper than face to face interviews. The response rate is between postal and face to face interview as people feel less inhibited about refusing to take part when approached over the telephone [81].

For scientific research, population surveys are very costly to undertake. Hence, researchers use results obtained from a sample group to generalize the information to the whole population. Calculation of the sample size depends upon the size of the population considered. In some cases, it is very straightforward, e.g., if a person wants to study the level of stress before and after a semester at a particular university, he can choose a fixed number of students from each department proportional to the strength of the department. However, with online surveys, the sample size is very tough to calculate as a lot of unknown factors are involved [82].

A similar survey conducted to identify the customer expectations on SM uses structured multiple choice, rating scale, open-ended questions. Statements were given to the respondents to grade it on a 5-point Likert scale (1= Strongly disagree and 5= Strongly agree), and the mean of the responses was used to identify the trend [83]. Another extensive study on

SM privacy uses data from 558 households obtained through two-step telephone interviews. The households were provided with an offer of selling their consumption data for research purposes and relevant risks in data transmission. The rate of acceptance of the offer showed how aware consumers are about their data [84].

### 4.3 Survey Methodology

The study of public perception is done through a survey of Swedish consumers. A total of 95 consumers were surveyed through a combination of methods including self-administered online questionnaires, face-to-face interviews, and social media platforms. The survey is run for a duration of 45 days. The demographics were classified on the basis of their occupation and the type of accommodation.

The population of Sweden as of 30 June 2019 is 10,281,189 and of Stockholm is 2,361,864. The total number of households in Sweden is more than 4 million. In Stockholm, rental apartments are more in number than tenant-owned apartments. The number of people working as engineers in 2012 was 307,336. This figure only includes jobs with engineering title. Considering the total population, the share of engineers in the country is 2%.

The sample considered for the survey is only a tiny percentage of Swedish consumers. As the survey mainly took place in Stockholm, majority of the respondents have rented accommodation. So, the results cannot be generalized to reflect the population's opinion. Also, to make the survey less time-consuming as possible (to increase response rate), questions with selectable answer options are given. The accuracy of the survey could have been increased if the respondents had to answer in their own words [85].

Though observations can be made from the results, the study might not replicate the actual preferences of people. As mentioned earlier in this Chapter, survey results mostly show the public values kept by the person and not their private preferences. But, to an extent, it is possible to get a detailed picture by comparing the historical data, the expert opinion, and the survey results.

The key players in SM markets are DSOs, electricity retailers, telecommunication companies, energy service providers, as well as end-users. Instead of trying to understand the public perception from one dimension, some industry experts in the field of smart metering are also consulted. At the time of writing, Sweden has a decade of experience in smart metering. The interviews with the experts have helped in identifying the response of the public during the first roll-out and the impact of GDPR in smart metering.

## 4.4 Results

The survey is mainly aimed at identifying the perception of SM privacy issues among the consumers and their willingness to pay for technologies offering a solution. Additionally, the readiness to invest in individual and shared PV panels is also investigated.

The survey had a completion rate of 100%, and the typical time spent was 90 seconds. The total number of respondents was 100. Majority of the respondents were obtained through an internet-based questionnaire. The demographics observed is given in Table 4.1.

*Table 4.1 Demographics of the survey*

Occupation	Percentage	Number
Engineer/Technical Field	47%	47
Non- technical	53%	53
<b>Type of accommodation</b>		
Rented apartment	70%	70
Own apartment	20%	20
Own villa	10%	10

The main observations made from the survey are as below.

- *Do you have any solar panels/EVs/other renewable energy systems at your home?*

*Motivation:* To see whether people are interested in investing in environment-friendly technologies

*Observations:* Only about 13.33% of the respondents who own their house have either a solar panel or an EV at their homes. More than half (56.67%) of the owners are working in non-technical fields. 30% of house owners are not interested in such technologies.

Of people who responded that they like to have such technologies in the future, there is no observable dependence on the type of job they are doing (technical – 50%, non-technical – 50%).

- *Would you be interested in investing in a shared PV system?*

*Motivation:* To understand whether consumers are ready to invest in shared systems like

pooled energy storage

Observations: 41% of the respondents said that they would consider the option depending upon the cost. Only 10% responded with a solid no.

- Are you aware of the privacy issues associated with the SMs?

Motivation: To check the extent to which people are aware of the privacy issues

Observations: 87% of the respondents are not aware of the SM privacy issues. Most of the respondents (61.54%) who are aware of the privacy issues are working in a technical field.

- Do you think it is a serious threat?

Motivation: Even if people are aware of the issues, they may not consider it to be serious

Observations: 75% of the respondents said that they think it is a serious privacy violation. Though they consider it as a serious privacy violation, 21% of the respondents were not ready to spend anything for prevention. An interesting comment made by a respondent in this question was “everywhere you go they are doing so why would this be any different.” Two others commented that whether or not it is a privacy issue depends upon who has access to the data.

- How and up to how much will you spend for a privacy- preserving technology?

Motivation: The amount people are willing to pay reflects the perceived seriousness of the issue

Observations: 21% responded that they would not spend anything. It is noteworthy that 71.43% of the people who are not ready to pay considered SM data leakage to be a serious issue. Also, 47.62% of the non-interested respondents had said that they would consider a shared PV system.

Out of the people who are willing to pay, the majority of them (62%) considered one-time investments. Their willingness to pay is shown in Figure 4.2<sup>4</sup>.

---

<sup>4</sup> 1 SEK = € 0.094 as on September 10, 2019

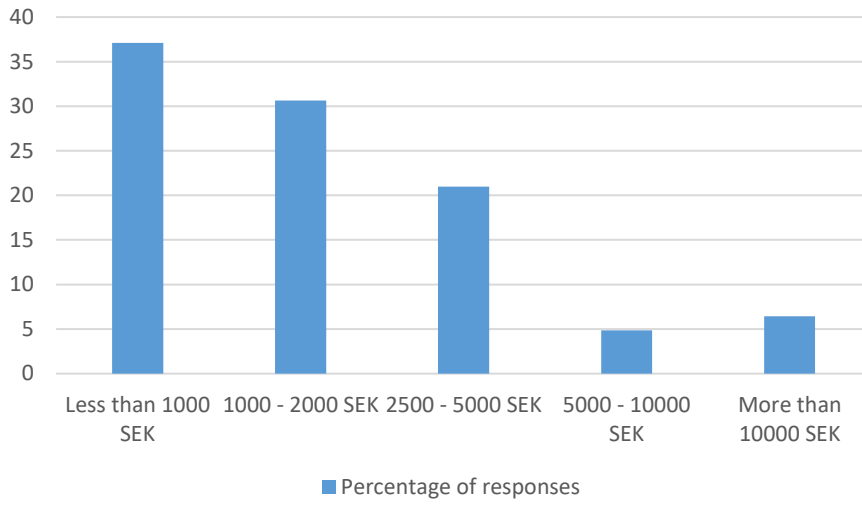

*a) One-time investment*

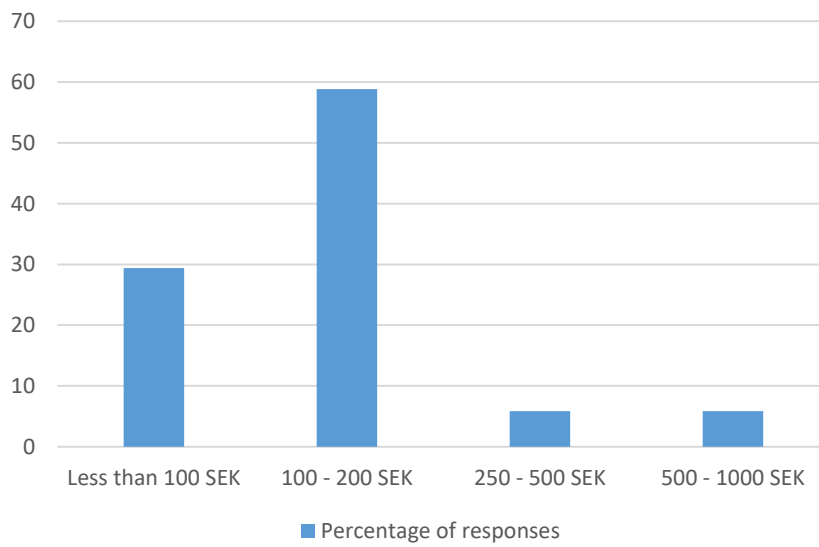

*b) Monthly installments*

Figure 4.2 Percentage of responses for the given answer choices

## 4.5 Smart meter privacy in Sweden: perspective of the companies

In order to understand the privacy issues from another perspective, some stakeholders in smart metering and related energy services were contacted. Discussions were held with spokespersons from Swedish Data Protection Agency (SDPA), Ellevio A B (a Swedish DSO), E.ON (an electric utility company) Power2U (an energy service provider) and OneNordic (smart meter providers). The interviews helped in shaping a better picture about smart metering infrastructure in Sweden. The main insights from the interviews are presented below.

Privacy is an abstract concept that does not have a solid definition. The same applies to personal data. The data from the SMs can be considered as a technical measurement data. For any technical system, increasing the number or frequency of measurements increases the accuracy to which we can understand the state of the system. But when it comes to SMs, increasing the measurement frequency (or resolution of the data) can reveal information regarding the behaviour of the resident. Hence, it can be difficult to distinguish between technical data and personal data is very vague.

According to a legal advisor from Datainspektionen (SDPA), *“Personal data is defined legally as ‘any information relating to an identified or identifiable natural person’. An ‘identifiable natural person’ is anyone who can be identified ‘directly or indirectly’, particularly by reference to identifiers like a name, an id-number, location data or any other factor that is specific to that person. As such, there may not be a need to distinguish between technical data and personal data – any data that meets this legal definition is personal data, regardless of whether it is also technical data. For example, GPS data that tracks the location of a car in real time may be considered personal data under this definition – especially if you know who’s driving”*.

In literature review, there was no mention of any protests against smart meters in Sweden. Datainspektionen (SDPA) is the authority responsible for data protection in Sweden. There has not been a any reported case of personal data breaches in related to SMs registered with SDPA. The spokesperson adds that *“...it is more difficult to speculate if there are any registered complaints by members of the public with regard to smart meters, though I can say that if there have been complaints in this field the SDPA has not undertaken any formal legal investigations with regard to such complaints. In general though, there may certainly be privacy concerns with regard to the data collected by smart meters, as this data could potentially be used to extrapolate the living habits of individuals who are using these devices.”*

One of the spokespersons from E.ON, an electric utility company also confirms this point. E.ON has experience in installing the SMs during the first massive roll-out during 2009 and is now preparing for the second roll-out from 2020. During the first roll-out, the company did not face

many obstacles regarding public acceptance. The spokesperson adds, *“privacy is a vital concern for us since it is a public company. Not only SM data, but all the consumer information is handled with utmost security. There has been a lot of discussion regarding GDPR especially over the last two years.”*

The second-generation roll-out of SMs in Sweden offers many additional features. The data resolution is increased from one hour to 15 minutes, and it is possible to monitor more types of data like phase voltage, phase current to monitor the power quality. Additionally, it is possible to disconnect the household and upgrade the software remotely. The meters will have a port which the customers can use to obtain their consumption data. The meters of OneNordic's communication infrastructure uses NarrowBand-IoT (Nb-IoT) which is a Low Power Wide Area Network communication protocol designed for sending sampled data. To secure the communication, SMs use a dedicated wireless network. Encryption of data is also a possibility that might be used in future models. SMs will be communicating only with the energy provider's network and not with the internet.

The second-generation SM roll-out has to take into account the changes in energy sector, especially the rising number of prosumers. In accordance with this trend, home energy management systems have also seen an increasing demand. Power2U works with real estate owners to optimize the energy use of their buildings. Currently, they use separate meters for monitoring real time energy consumption. The spokesperson from the company says, *“We investigated the use of SM data. But it involves a lot of paperwork. The owner has to get consent from the DSO. There is no interface to do it easily. Each real estate owner has to do it individually. Also, the data that we use here is real time data, sampled around 1-5 seconds. It will be difficult to work with SM data for some applications.”*

The electric utility companies require special permissions from the owner to let third parties access the services. This was confirmed by both Ellevio's as well as E.ON's spokespersons. The companies require a written confirmation from the owner to give access to third-parties. Absence of a written permission would result in violation of GDPR. Also, as per EU Directive 95/46/EC, the users have to give unambiguous consent to any third-party for accessing their data. Most of the companies have provided their privacy policy in their webpages where it is possible to see how the data is processed, how long it is retained and with whom it is shared with.

Power2U has aggregated batteries from different buildings to provide revenue to the owners and to offer services to the grid. Currently, they are not involving the residents of the building. From the survey taken from the consumers, a good share of people is interested in investing in shared renewable energy technologies. The company also developed a vehicle to grid solution that needs active participation from the consumers. On asking how they convince people to join the program, they said, *“...right now, the vehicles we are using are only from a*



*real estate company. We might be able to convince people by communicating with them. If they can get a revenue out of it or if they can charge their cars at a cheaper price, they might be interested in our smart charging.”*

The interviews with experts helped in getting deeper insights to smart metering in Sweden. By increasing the number of interviewees, a multidimensional picture of the challenges in smart metering in Sweden can be formed.

## 4.6 Summary

Public opinions can determine the future of a developed technology, especially when a fundamental right like privacy is involved. The acceptance of technology differs from place to place. That being said, events in one location can always trigger a chain of reactions in another place, particularly due to the increased globalization and connectivity. From a social perspective, it is interesting to understand the perception of the public about an issue and see their interest in a developed solution.

A survey is a convenient tool to identify public perception towards a specific topic. As plenty of survey methods are available, it is up to the researcher to decide on what is best for his/her study. Though surveys can give an idea on how people think, often the preferences shown by the respondents are a reflection of what their morals are and not what their actual preferences are. Additionally, the responses of a survey taking person depend on how a question is framed and the available options. Unintentionally, a researcher might be nudging the respondent to choose an option he/she might not be actually interested in. Psychological factors like this make it more challenging to understand the real public opinion.

Rather than sticking to a single methodology, a combination of methods can be adopted to comprehend the situation at a deeper level. Historical data from articles and scientific journals, social media discussions, local newspapers, and expert opinions can help investigate public views over a time period.

To conclude, the study of public perception is a complex topic. Unlike scientific experiment results, which has a level of certainty, the public opinions are highly volatile and dependent on a lot of external factors. In forming and expressing their own opinions, people consider the opinions of others (Solomon Asch famously demonstrated the effect of peer pressure to conform on judgement and individuality of a person [86]. In a group, only one participant was a genuine subject for the experiment and the others were trained to give a selected response. When the others in the group selected wrong answers, the subject of the study also changed his answers accordingly). Media is also shown to have a high influence on how people think about an issue as well as how people think others see an issue [25]. So, if there is a 10-minute

coverage on smart meter privacy issues on national news, the results of the same survey on the very next day will be entirely different. In the end, these surveys can be beneficial in underlining the importance of communication between academia, industry, and the public.

## 5. Discussion

Lately, data privacy issues have gained a lot of attention around the world. As the world is becoming more connected, the amount of data harvested is increasing. Most of the times, people do not even realize that combining information from various sources can create a near-realistic picture of them. For instance, considering location tracking, the information about where the person was at a particular time can be found out from travel (metro/bus/train) cards, credit/debit cards, smartphones, smartwatches, computers or CCTVs installed around the cities. Earlier such tracking was mainly used by law enforcement agencies. Now, with increasing sources of information, it is a challenge to find out how the data is used and with whom it is shared.

Recently, Cambridge Analytica, a political consultancy company, was held under scrutiny when it improperly obtained the data of up to 87 million Facebook (a popular social media platform) users. The data was acquired through a quiz which invited the users to find out their personality types. Unknown to the users, this data was then used to psychologically profile US voters and target them with Donald Trump's 2016 presidential campaign materials [1], [2]. Though various studies had raised privacy concerns about Facebook for a very long time, the incident with Cambridge Analytica gained a lot of media attention. A study shows that users' trust in Facebook has reduced by 66% after this incident [3].

The scandal was also successful in bringing data privacy into public interest. When we live in an interconnected system, it is important to understand that our data has a big value. Innovative techniques have even targeted seemingly harmless devices. For example, a North American casino was hacked through a fish tank with internet-connected sensors [4]. In Europe, legislation like GDPR has helped a lot in creating awareness about these issues and in having a check on data mining.

As mentioned in earlier chapters, SM data contains sensitive information regarding the users. If the data generated from the SMs are not regulated by an authority, there is a chance that it finds its way to the wrong hands. GDPR is applicable only in Europe. In the absence of such strong regulations, consumers need to have options to preserve the data on their own. From an academic perspective, it is interesting to see what a consumer can do to prevent such situations.

In this chapter, a summary of observations about the survey is given. The limitations of the study and the future scope are discussed.

## 5.1. Summary of findings

The minimum capacity requirement for an ESS to prevent data leakage was studied. The following points are assumed:

- The information leakage is minimum when the power flow curves are piecewise linear
- The sizing of ESS is done solely to mitigate privacy issues and not for economic applications

Through the proposed algorithm, the power flow is maintained constant for intervals. Different cases with varying household consumptions and solar production are simulated, and the variation in the ESS capacity is noted.

### 5.3.1 Sizing of ESS for mitigating privacy issues

When the user injects power back to the grid, the ESS capacity required by the user is slightly higher than the case of a user without grid injection. This can be attributed to the increased charge-discharge cycles, as explained in Chapter 2 (Figure 5.5.1). Frequent charge-discharge cycles can affect the life of an ESS. The cycle life of an ESS is the highest when the depth of discharge (DoD) is 0% [5]. In figure 4.1, the relationship between the number of cycles and usable capacity at different DoD of a Lead-Acid battery can be seen. For lessening the effect of charge cycles on the lifetime of the ESS, a maximum of 1.5 cycles/day is defined in the algorithm.

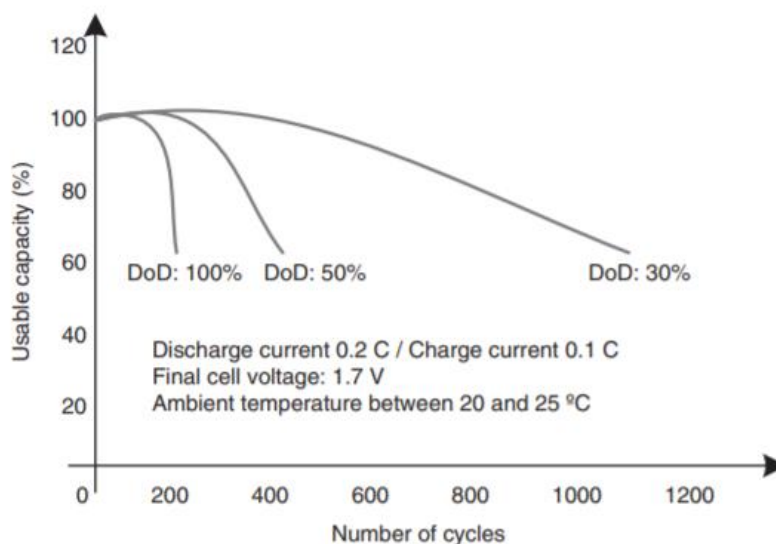

Figure 5.5.1 The dependence of the lifetime of a lead-acid battery on the number of cycles

*and the DoD. Reproduced from Power-Sonic Corporation [87]*

It is seen that when the user does not inject power back to the grid (case 1), the minimum capacity required to maintain privacy is about 30-50% of the typical household consumption. As solar energy production increases, the capacity required decreases slightly. This can also be due to the charging cycle. When the user is not injecting power to the grid, the ESS can feed the domestic loads on its own for a very long duration. Before it reaches the lower limit, the solar panel production can complement the grid in recharging the ESS.

Now, let's assume the user who injects power back to the grid (case 2) has the same ESS capacity as the user who does not inject back to the grid. The ESS then discharges energy to the domestic loads as well as to the grid. Due to the faster discharge, the energy level drops below the lower threshold within 2-3 hours, and the ESS will start charging again on solar power. So, on a sunny day, an ESS will undergo two complete cycles compared to the single cycle in the case of the first case. This is why ESS capacity increases with an increase in solar power in the second case.

### 5.3.2 Study of public perceptions

The survey results show a sizeable amount of people unaware of SM privacy issues in Sweden. This aligns with the comments from the experts. In Sweden, there have not been any reported issues regarding SM privacy yet. Hence, people were not inherently aware of the potential problems of the SM. Only 21% of the respondents said that they would not invest in any technology preventing SM privacy issues. Depending upon the willingness to pay expressed by the respondents, we can review the ESS options available and its cost.

*Table 5.1 The price of different types of batteries with their round-trip efficiencies*

Battery System	Storage	Price in 2016 (SEK/kWh)	Expected price in 2030 (SEK/kWh)	Round-trip efficiency (%)
Li-ion cell		2000 - 8000 <sup>5</sup>	745 - 5560	80 - 100
Lead-acid		1000 - 4600	484 - 2324	70 - 90
Flow batteries		3000 - 16300	1000 - 5600	70 - 80

For residential applications, all types of batteries (e.g., lead-acid, Li-ion, redox flow) can be

<sup>5</sup> Does not include Lithium Titanate (LTO) based batteries. The installation costs of LTO-batteries range between 4600 and 12000 SEK/kWh

used. Currently, Li-ion systems dominate the home energy storage market [88]. Compared to BESS, supercapacitors offer higher life and higher specific power capacities. But, major disadvantages of the supercapacitor are its high self-discharge rates (10-20 % per day) and low energy density. Also, as a home energy storage system, supercapacitors have not reached the maturity yet, and researches are still being carried out on it.

Hence, only battery systems are considered for cost analysis. shows the price of BESS in 2016 and expected prices in 2030 along with round-trip efficiencies. The price of batteries varies over the applications, country, lifetime, etc. For example, Tesla Powerwall is a commercial ESS model developed for home energy storage. It can be combined with solar panels or can be installed as a back-up power supply. The cost break-up for a Powerwall model is given below.

14 kWh Powerwall battery: 79,800 SEK (Included VAT: 13 450 SEK)

Support Hardware: 7,850 SEK

Installation Costs: 11,000 – 33,100 SEK

From the survey results, it is seen that a very small percentage (3 out of 95) of consumers were ready to pay more than 10,000 SEK as a one-time payment for mitigating SM privacy issues. In monthly installments also, nobody was willing to pay more than 1000 SEK/month. It should be noted that the lack of willingness to pay high amounts is not because the consumers do not think of SM privacy issues as serious. More than 75% of the respondents thought that SM data leakage is a serious threat when they were told about the potential problems. Also, it should be noted that the respondents were not introduced to the idea of using ESS for SM privacy issues.

In economic terms, willingness to pay (WTP) is the maximum amount a customer is ready to pay for a particular product or service. In this survey, the product or service was not introduced to the customer. From their perspective, a SM data leakage mitigation tool can be anything from a software update that costs less than 500 SEK to an ESS that costs more than 50,000 SEK. The survey can be deemed successful in understanding the market potential as it shows the share of people not interested in spending money on the product.

One of the famous quotes about innovation attributed to Henry Ford is: "If I had asked people what they want, they would have said faster horses". Some entrepreneurs use this quote to state that unless new products are introduced to people, they won't realize the potential of the product. But interpreting this quote from another side, it can be said that the need of the people is evident in their answers, *faster* horses. Whether the company comes up with an internal combustion engine or a performance-enhancing drug for the horses, people are interested in that particular attribute of the product.

Similarly, it can be said that the quality that the respondents are looking for in a SM privacy-enhancing tool is security. What sets a car different from a horse is the additional features it offers. The price of a car mostly increases with increase in additional features it provides. Likewise, a method to increase the appeal of the ESS is to incorporate more functionalities in it. Already home energy storage devices are being used with renewable energy production. Instead of providing only SM data leakage prevention, it can be used to complement other benefits of ESS like maximum utilization of solar power, back-up energy for electricity outage etc.

Another way is to use used EV batteries or second-life batteries. As mentioned in the previous chapter, the capacity of a single EV battery is higher than the daily household consumption. The cost of such batteries will be lesser than the cost of new batteries, but the performance will be reduced. Another issue is the safety of the batteries. Studies have shown that the used car batteries can achieve competitive performance if we ignore reduced round trip efficiency. EV models like Nissan Leaf can be adapted for vehicle-to-grid power (V2G) transfer. The car batteries of Nissan will outlast the vehicle by 12 years [89]. As a flagship project, 3 MW of energy storage was installed at Amsterdam ArenA which includes a combination of new and used EV batteries. The solar panels and the ESS together will ensure that the stadium has backup power during outages and also complement the grid during high consumption periods.

The survey results and expert opinions suggest a rise in customer interest in renewable energy technologies. Increased demand for renewable energy will further reduce the price of the ESS. Also, a good share of respondents (47%) was interested in community-level shared technologies. If the pooling of ESS can reduce the capacity needed per household, then such monetary benefits might attract the consumers to invest in shared technologies as stated by the spokesperson from Power2U. The community-level shared technology should be of interest as half of the dwellings in Sweden are multi-dwelling buildings (i.e., apartments). The Swedish government has an aim to make all new buildings after 2021 as net-zero energy buildings. From the interviews with Power2U, it was seen that currently, real estate owners are doing this without the participation of residents.

## 5.2. Limitations

It can be said that the study has a very narrow scope. The main priority was to minimize information leakage. The study had not considered the effects of EV charging or buying of a new heavy load appliance like air conditioning or any other unusual high loads. Additionally, the sizing of the ESS considers the minimum size of ESS required for a household. If the user has a PV panel, it is advisable to opt for an ESS which is roughly the size of average energy production from the solar panel. This will help to increase the amount of energy that can be stored in the ESS.

There are two thresholds defined in the algorithm, the upper threshold which was set at 80% of actual capacity and lower threshold, which was 20% of actual capacity. Above the upper threshold, the ESS charges only from the solar and not from the grid. The ESS capacity changes depending on where these values are set. If we add weather forecast to the simulation, and increase and decrease the thresholds depending upon the forecasted solar energy production, the ESS will be able to charge entirely on solar energy.

There are many assumptions that are made in the sizing of the ESS for simplification. In practical cases, sizing of ESS should be done, taking into consideration many technical factors like charge-discharge rates, maximum current, SOC, etc. In this project, the algorithm checks only the energy levels of the ESS to transfer power from/to the grid. The number of households considered for the study is only four. To increase the accuracy of the formulated equation, a large number of households have to be considered.

One of the main limitations of the surveys is the randomness of the sample group. The demographics of the sample group is tough to select when online questionnaires are used. Multiple-choice questions also introduce a level of bias into the results. In the absence of time constraints and guaranteed respondents, it is better to ask the respondents to answer in their own words. When an optional remark choice was available, some of the respondents had shared their views about SM privacy issues. Even though analyzing a large number of written answers is a hard task, it will be really valuable if the researcher wants to understand the concerns of the people.

### 5.3. Suggestions for further research

The number of EV owners in Sweden is increasing. There were almost 50,000 electric cars in Sweden in 2017. Clearly, it will be interesting to see the effects of EV charging on SM data curves and how the capacity requirement varies in this case.

In this study, the grid-tied customer was not making any revenues out of the power he/she was injecting. For future work, it will be interesting to combine the aim of maximizing the revenue along with maintaining the linearity. This might be challenging to implement as one has to consider weather forecast and load forecast also.

Though many studies have been done on using the ESS to mitigate SM privacy issues, only algorithms have been proposed. If a real EMU is programmed with the proposed algorithm and tested under lab conditions, the challenges to this solution can be further investigated. But as mentioned earlier, factors such as current, SOC, voltage, load power have to be considered for the sizing.

Currently, Sweden was the only country considered for the study of public perception. Similar



studies in the UK, Germany or the USA might be able to show the main concerns of people regarding SM adoption and the reasons for such low acceptance. To achieve a full roll-out, it is advisable to know why people are not accepting the technology though agencies have been spreading awareness. Opinions from smart metering experts from these countries will also be crucial in identifying what rectifying steps can be taken.

## Conclusion

SM data privacy is an important issue which all customers should be aware of. Although a lot of academic research has been carried out on the topic, it is highly doubted that the SM users are aware of it. The concerns regarding SMs have been concentrated on some geographic locations, as a result of which those regions are lagging behind their SM roll-out target. SMs might not be a necessity, but it should be stressed that SMs are the link that connects the households to an SG infrastructure. There are many benefits offered by the SM like accurate measurements, bidirectional measurement, power quality measurement, etc. Hence, SM privacy issues should not be a barrier in transforming to a 100% SM system.

In this study, an algorithm to charge and discharge an ESS was proposed. The ESS charges from the grid (and solar, when available) till an upper threshold is reached, and it stops charging from the grid instead charges only from the solar. When SOC = 100%, it discharges till a lower threshold, and after that, it charges again. Two user cases were studied with this algorithm: a user who does not inject power to the grid (wastes the excess energy) and a user who does inject power back to the grid when the ESS charges to its capacity.

It was seen that when the user injects power back to the grid, the number of charge cycles increase compared to the case where he does not inject power back to the grid. Hence, the capacity needed for a system with grid injection is slightly higher than the capacity needed for a system which does not inject power. Though minimum ESS capacity is determined in the study, the higher the ESS capacity there is, the better it can act as a stand-alone system. When the capacity of the ESS is equal to or more than the household consumption, then the ESS will not get completely discharged before the solar production period next day (10 am – 6 pm). Hence, energy accumulates in the ESS till solar energy production is really low (cloudy days) when it charges from the grid again.

The sizing of the ESS was done considering the piecewise linearity and number of charge cycles per day. When the user does not inject power to the grid, the ESS capacity required by the user reduces with increasing solar production. When the user injects power to the grid, the ESS capacity increases with increasing solar production. An equation was formulated based on the data observed for the households to calculate the minimum ESS capacity required for a given household energy consumption and solar energy production.

The second objective of the project was to understand public perception regarding SM privacy issues. The survey shows a large share of people unaware of SM privacy issues. The privacy issues were briefly explained to the respondents and they were asked whether or not it is a serious issue. Majority of the respondents think that it is a serious privacy issue. Half of the respondents are interested in having a shared renewable energy system. The customer's

willingness to pay for the SM privacy-enhancing tools are identified.

Energy storage systems are currently very expensive. Hence, very few respondents were willing to pay more than 10,000 SEK for a SM data leakage solution. One way to attract the consumer is to increase the number of functionalities of the ESS so that the consumers can get multiple benefits for the same price. Another method is to pool the houses together under an ESS so that the individual capacity needed for a household decreases.

The expert opinions verify that there are very fewer issues with SM privacy in Sweden. There have not been any reported cases of SM privacy yet. The second massive roll-out of SMs in Sweden prioritize on increasing the power quality and customer engagement. Security of SMs is considered with utmost priority. The communications channels for SM employs a dedicated infrastructure utilizing Nb-IoT. The rising interest in RES has demanded major changes in the power sector, giving rise to many new services and products.

To conclude, there is a lot of research opportunity in SM privacy issues and its mitigation. The charm of the problem lies in the number of ways in which the solution can be approached, from legal measures to communication protocols. While one method is not superior to others, the selection of a solution depends on when and where it should be implemented. This study has solely focused on Sweden, an EU country where privacy considered a fundamental right. However, the multiple benefits of ESS makes it a good option to invest in for SM data privacy.



## Bibliography

- [1] ERGEG, "Smart Metering with a Focus on Electricity Regulation," *E07-Rmf-04-03*, no. October, 2007.
- [2] F. Brian, M. Anthony, D. Argenio, G. Brook, and H. Donald, "Methods and Systems for Presenting an Advertisement Associated with an Ambient Action of a User," *US Pat. Trademark Off. Pat. Appl. Full Text Image Database*, 2012.
- [3] R. J. González, "Hacking the citizenry?," *Anthropol. Today*, vol. 33, no. 3, pp. 9–12, 2017.
- [4] L. Jaakonanti, "Översättning , en sammanfattning av Ei : s rapport om funktionskrav på elmätare Summary of the report from Ei about smart meters ( Ei R2017 : 08 ) Smart metering functionalities," vol. 1, no. 3, pp. 1–3, 2018.
- [5] Eurostat, "Share of energy from renewable sources Source of data : Eurostat NRG \_ BAL : Renewable energy sources UNIT : Percentage [ nrg \_ ind \_ ren ]," p. 34, 1990.
- [6] European Parliament and the Council of the European Union, "Directive 2009/28/EC of the European Parliament and of the Council of 23 April 2009," *Off. J. Eur. Union*, vol. 140, no. 16, pp. 16–62, 2009.
- [7] Swedish Energy Agency, *Energy in Sweden 2018, An Overview*, vol. II. 1996.
- [8] Swedish Energy Agency, "Energy in Sweden 2013," p. 115, 2012.
- [9] "Energy in Sweden 2015," p. 115, 2015.
- [10] EPBD 2002/91/EC, "Directive 2002/91/EC of the European Parliament and of the Council of 16 December 2002 on the energy performance of buildings," *Off. J. Eur. Union*, pp. 65–71, 2002.
- [11] European Parliament, "Directive 2012/27/EU of the European Parliament and of the Council of 25 October 2012 on energy efficiency, amending Directives 2009/125/EC and 2010/30/EU and repealing Directives 2004/8/EC and 2006/32/EC," *Off. J. Eur. Union*, vol. 14/11/2012, no. November 2010, pp. 1–56, 2012.
- [12] EU, "DIRECTIVE 2009/125/EC -establishing a framework for the setting of ecodesign requirements for energy-related products," *Off. J. Eur. Union*, pp. 10–35, 2009.
- [13] Swedish Energy Agency, "Energy in Sweden," 2017.
- [14] I. The MathWorks, "MATLAB and Statistics Toolbox Release R2017a." Natick, Massachusetts.
- [15] A. Mannikoff and H. Nilsson, "Sweden &#x2014; Reaching 100% &#x2018;smart meters&#x2019; July 1, 2009," *2009 IEEE Power Energy Soc. Gen. Meet.*, pp. 1–4, 2009.
- [16] S. Zhou and M. A. Brown, "Smart meter deployment in Europe: A comparative case

- study on the impacts of national policy schemes,” *J. Clean. Prod.*, vol. 144, no. 2017, pp. 22–32, 2017.
- [17] European Commission, “Internal energy market,” *Fact Sheets Eur. Union - 2019*, no. April 2009, pp. 1–5, 2019.
- [18] M. S. Energy, “FIND OUT WHAT IS HAPPENING IN YOUR COUNTRY.” [Online]. Available: <http://my-smart-energy.eu/my-country>. [Accessed: 01-Sep-2019].
- [19] S. S. S. R. Depuru, L. Wang, and V. Devabhaktuni, “Smart meters for power grid: Challenges, issues, advantages and status,” *Renew. Sustain. Energy Rev.*, vol. 15, no. 6, pp. 2736–2742, 2011.
- [20] X. Fang, S. Misra, G. Xue, and D. Yang, “Smart grid - The new and improved power grid: A survey,” *IEEE Commun. Surv. Tutorials*, vol. 14, no. 4, pp. 944–980, 2012.
- [21] H. Tram, “Technical and operation considerations in using smart metering for outage management,” *Transm. Distrib. Expo. Conf. 2008 IEEE PES Powering Towar. Futur. PIMS 2008*, pp. 1–3, 2008.
- [22] M. States and E. Parliament, “EU preparations for the roll-out of smart metering systems (2012/148/EU),” no. 2011, pp. 9–22, 2012.
- [23] I. Rinta-jouppi and V. D. Nordic, “Smart Meter – a field report from Sweden - presentation,” *Vattenfall Distrib. Nord.*, 2009.
- [24] D. G. Hart, “Using AMI to realize the Smart Grid,” *IEEE Power Energy Soc. 2008 Gen. Meet. Convers. Deliv. Electr. Energy 21st Century, PES*, pp. 1–2, 2008.
- [25] E. Commission, “Cost-Benefit analysis & state of play of smart metering deployment in the EU-27,” 2014.
- [26] J. Lasch, “Smart metering,” *ABB Rev.*, no. 1, pp. 76–78, 2010.
- [27] B. Römer, P. Reichhart, J. Kranz, and A. Picot, “The role of smart metering and decentralized electricity storage for smart grids: The importance of positive externalities,” *Energy Policy*, vol. 50, pp. 486–495, 2012.
- [28] J. M. Alcalá, J. Ureña, S. Member, Á. Hernández, S. Member, and D. Gualda, “Sustainable Homecare Monitoring System by Sensing Electricity Data,” vol. 17, no. 23, pp. 7741–7749, 2017.
- [29] U. Greveler, P. Glösekötterz, B. Justusy, and D. Loehr, “Multimedia content identification through smart meter power usage profiles,” *Proc. Int. Conf. Inf. Knowl. Eng.*, 2012.
- [30] G. Eibl and D. Engel, “Influence of Data Granularity on Smart Meter Privacy,” vol. 6, no. 2, pp. 930–939, 2015.
- [31] M. A. Lisovich, D. K. Mulligan, and S. B. Wicker, “Exploiting In-Home Data,” no. February, pp. 1540–7993, 2010.

- [32] P. McDaniel and S. McLaughlin, "Security and Privacy Challenges in the Smart Grid," pp. 75–77, 2009.
- [33] E. McKenna, I. Richardson, and M. Thomson, "Smart meter data: Balancing consumer privacy concerns with legitimate applications," *Energy Policy*, vol. 41, pp. 807–814, 2012.
- [34] E. L. Quinn, *Privacy and the New Energy Infrastructure Center for Energy and Environmental Security (CEES)*, no. 09. 2008.
- [35] P. Van Aubel and E. Poll, "Smart metering in the Netherlands : what , how , and why," *Digit. Secur. group, Inst. Comput. Inf. Sci.*, pp. 1–8, 2018.
- [36] European Parliament, "Directive 95/46/EC," *Off. J. Eur. Union*, no. L, pp. 31–50, 1995.
- [37] Echr-cedh, "Guide on Article 8 - Right to respect for private and family life, home and correspondence," no. August, 2018.
- [38] Cranium, "Smart Energy and GDPR for utility," 2019.
- [39] T. E. Commission, "Proposal for a Directive of the European Parliament and of the Council on common rules for the internal market in electricity (recast)," vol. 0380, no. 2016, 2017.
- [40] C. Cuijpers and B.-J. Koops, "The 'smart meters' bill : a privacy test based on article 8 of the ECHR," no. October, p. 39, 2008.
- [41] R. van Gerwen, F. Koenis, M. Schrijner, and G. Widdershoven, "Smart meters in the Netherlands: Revised financial analysis and policy advice," pp. 12–19, 2010.
- [42] EDPS, "Opinion of the European Data Protection Supervisor on the Commission Recommendation on preparations for the roll-out of smart metering systems," pp. 1–18, 2012.
- [43] International Smart Grid Action Network, "AMI CASE Case07 / NETHERLANDS," 2014.
- [44] P. Barbosa, A. Brito, and H. Almeida, "A Technique to provide differential privacy for appliance usage in smart metering," *Inf. Sci. (Ny).*, vol. 370–371, pp. 355–367, 2016.
- [45] J. Won, C. Y. T. Ma, D. K. Y. Yau, and N. S. V. Rao, "Privacy-Assured Aggregation Protocol for Smart Metering: A Proactive Fault-Tolerant Approach," *IEEE/ACM Trans. Netw.*, vol. 24, no. 3, pp. 1661–1674, 2016.
- [46] E. Liu and P. Cheng, "Achieving Privacy Protection Using Distributed Load Scheduling: A Randomized Approach," *IEEE Trans. Smart Grid*, vol. 8, no. 5, pp. 2460–2473, 2017.
- [47] C. Rottondi, A. Barbato, and G. Verticale, "A privacy-friendly game-theoretic distributed scheduling system for domestic appliances," *2014 IEEE Int. Conf. Smart Grid Commun. SmartGridComm 2014*, no. 40545387, pp. 860–865, 2015.
- [48] S. Maharjan, Q. Zhu, Y. Zhang, S. Gjessing, and T. Başsar, "Dependable demand response management in the smart grid: A stackelberg game approach," *IEEE Trans.*

- Smart Grid*, vol. 4, no. 1, pp. 120–132, 2013.
- [49] R. Cepeda, T. A. Lewis, G. Kalogridis, C. Efthymiou, and S. Z. Denic, “Privacy for Smart Meters: Towards Undetectable Appliance Load Signatures,” *2010 First IEEE Int. Conf. Smart Grid Commun.*, pp. 232–237, 2010.
- [50] D. Mansson, “Sizing Energy Storage Systems used to Improve Privacy from Smart Meter Readings for Users in Sweden,” *Proc. - 2018 IEEE PES Innov. Smart Grid Technol. Conf. Eur. ISGT-Europe 2018*, pp. 5–10, 2018.
- [51] D. Varodayan and A. Khisti, “Smart meter privacy using a rechargeable battery: Minimizing the rate of information leakage,” *ICASSP, IEEE Int. Conf. Acoust. Speech Signal Process. - Proc.*, pp. 1932–1935, 2011.
- [52] V. S. K. M. Balijepalli, V. Pradhan, S. A. Khaparde, and R. M. Shereef, “Review of demand response under smart grid paradigm,” in *2011 IEEE PES International Conference on Innovative Smart Grid Technologies-India, ISGT India 2011*, 2011, pp. 236–243.
- [53] M. Mohammadi, Y. Noorollahi, and B. Mohammadi-Ivatloo, “Impacts of Energy Storage Technologies and Renewable Energy Sources on Energy Hub Systems.”
- [54] P. D. ' Aprile, J. Newman, and D. Pinner, “The new economics of energy storage.”
- [55] J. D. Mondol, Y. G. Yohanis, and B. Norton, “Optimising the economic viability of grid-connected photovoltaic systems,” *Appl. Energy*, vol. 86, no. 7–8, pp. 985–999, 2009.
- [56] F. M. Andersen, H. V. Larsen, and T. K. Boomsma, “Long-term forecasting of hourly electricity load: Identification of consumption profiles and segmentation of customers,” *Energy Convers. Manag.*, vol. 68, pp. 244–252, 2013.
- [57] Z. Wang and S. Wang, “Grid power peak shaving and valley filling using vehicle-to-grid systems,” *IEEE Trans. Power Deliv.*, vol. 28, no. 3, pp. 1822–1829, 2013.
- [58] I. E. Agency, “Global EV Outlook 2018,” *Glob. EV Outlook 2018*, 2018.
- [59] G. Lorenzi, C. Augusto, and S. Silva, “Comparing demand response and battery storage to optimize self-consumption in PV systems,” 2016.
- [60] B. Battke, T. S. Schmidt, D. Grosspietsch, and V. H. Hoffmann, “A review and probabilistic model of lifecycle costs of stationary batteries in multiple applications,” *Renew. Sustain. Energy Rev.*, vol. 25, pp. 240–250, 2013.
- [61] “PV Output.” [Online]. Available: <https://pvoutput.org/>. [Accessed: 01-Jun-2019].
- [62] National Audit Office, “Rolling out smart meters,” no. November 2018, 2019.
- [63] BEIS, “Smart Meter Statistics-Quarterly Report to end March 2019,” no. May, pp. 1–18, 2019.
- [64] Smart Energy GB, “About Smart Energy GB,” 2019.



- [65] Stop Smart Meters, "Live Blood Analysis – Observable Effects of RF / MW Radiation from ' Smart ' Meter."
- [66] J. T. Bushberg, K. R. Foster, J. B. Hatfield, A. Thansandote, and R. A. Tell, "IEEE committee on man and radiation-COMAR technical information statement radiofrequency safety and utility smart meters," *Health Phys.*, vol. 108, no. 3, pp. 388–391, 2015.
- [67] S. Kasperson, Roger E and Renn, Ortwin and Slovic, Paul and Brown, Halina S and Emel, Jacque and Goble, Robert and Kasperson, Jeanne X and Ratick, "The social amplification of risk: a conceptual framework," *Risk Anal.*, vol. 8, no. 2, pp. 177–187, 1988.
- [68] D. Smith and J. McCloskey, "Risk communication and the social amplification of public sector risk," *Public Money Manag.*, vol. 18, no. 4, pp. 41–50, 1998.
- [69] R. J. Bord, A. Fisher, and R. E. O'Connor, "Public perceptions of global warming: United States and international perspectives," *Clim. Res.*, vol. 11, no. 1, pp. 75–84, 1999.
- [70] K. Mulder, "The dynamics of public opinion on nuclear power. Interpreting an experiment in the Netherlands," *Technol. Forecast. Soc. Change*, vol. 79, no. 8, pp. 1513–1524, 2012.
- [71] T. Katsuya, "Public response to the Tokai nuclear accident," *Risk Anal.*, vol. 21, no. 6, pp. 1039–1046, 2001.
- [72] M. Wolsink, "Wind power and the NIMBY-myth: Institutional capacity and the limited significance of public support," *Renew. Energy*, vol. 21, no. 1, pp. 49–64, 2000.
- [73] R. Wüstenhagen, M. Wolsink, and M. J. Bürer, "Social acceptance of renewable energy innovation: An introduction to the concept," *Energy Policy*, vol. 35, no. 5, pp. 2683–2691, 2007.
- [74] P. Review, "Philosophical Review Review Reviewed Work ( s ): The Economy of the Earth : Philosophy , Law , and the Environment by Mark Sagoff Review by : Lawrence H . Simon Source : The Philosophical Review , Vol . 100 , No . 4 ( Oct . , 1991 ), pp . 684-687 Published," 2019.
- [75] K. Ek, "Public and private attitudes towards 'green' electricity: The case of Swedish wind power," *Energy Policy*, vol. 33, no. 13, pp. 1677–1689, 2005.
- [76] E. Devlin, "Factors Affecting Public Acceptance of Wind Turbines in Sweden," *Wind Eng.*, vol. 29, no. 6, pp. 503–511, 2005.
- [77] I. Carlman, "Wind power in Denmark! Wind power in Sweden?," *J. Wind Eng. Ind. Aerodyn.*, vol. 27, no. 1–3, pp. 337–345, 1988.
- [78] Groves, M. Robert, F. J. Fowler Jr, and M. Couper, *Survey Methodology*. 2011.
- [79] "smart mätare - Twitter Search." [Online]. Available: [https://twitter.com/search?q=+smart+mätare&src=recent\\_search\\_click](https://twitter.com/search?q=+smart+mätare&src=recent_search_click). [Accessed: 29-Aug-2019].

- [80] “News about smart meter on Twitter.” [Online]. Available: [https://twitter.com/search?q=+smart+meter&src=typed\\_query&f=user](https://twitter.com/search?q=+smart+meter&src=typed_query&f=user). [Accessed: 29-Aug-2019].
- [81] K. Kelley, B. Clark, V. Brown, and J. Sitzia, “Good practice in the conduct and reporting of survey research,” *Int. J. Qual. Heal. Care*, vol. 15, no. 3, pp. 261–266, 2003.
- [82] “Interpersonal Computing and Technology: An Electronic Journal for the 21st Century,” 1998.
- [83] L. Lave *et al.*, “Preparing for smart grid technologies: A behavioral decision research approach to understanding consumer expectations about smart meters,” *Energy Policy*, vol. 41, pp. 790–797, 2011.
- [84] SPARKS, “Smart Grid Cyber Security : Advice to Policy Makers on European Level – Legal and Social Issues,” no. 608224.
- [85] H. Schuman and J. Scott, “Problems in the Use of Survey Questions to Measure Public Opinion,” 1987.
- [86] S. E. Asch, “Effects of group pressure on the modification and distortion of judgments,” *Groups, Leadersh. men*, pp. 177–190, 1951.
- [87] F. Díaz-González, A. Sumper, and O. Gomis-Bellmunt, *Energy storage in power systems*. 2016.
- [88] IRENA, *Electricity storage and renewables: Costs and markets to 2030*, no. October. 2017.
- [89] L. Grecia, “Nissan Leaf batteries will outlast the vehicle by up to 12 years,” *The Top Gear Philippines*, May-2019.