

SPECIAL ISSUE



TECHNICAL, SCIENTIFIC
AND
RESEARCH REPORTS

VOL.10 (2018)

Heterodyne radiometer instrument concept studies
(REPORT - DIAST Project)

Heterodyne radiometer instrument concept studies
(REPORT - DIAST Project)

Vanni Nardino^{(1,*),} Massimo Baldi^(1,**)

(1) "Nello Carrara" Institute of Applied Physics, CNR Florence Research Area, Via Madonna del Piano 10, 50019 Sesto Fiorentino (FI), Italy

(*) v.nardino@ifac.cnr.it

(**) m.baldi@ifac.cnr.it

Contents

1	Introduction	3
1.1	THz FREQUENCY RANGE.....	3
2	Heterodyne detection	3
2.1	HETERODYNE PRINCIPLE.....	3
2.2	IMAGE FREQUENCY	4
2.3	MIXER.....	5
3	THz sources	6
3.1	FIR LASERS	6
3.2	QC LASERS.....	6
3.3	SEMICONDUCTOR TERAHERTZ GASE, ZNTE CRYSTALS.....	6
4	THz local oscillator	7
4.1	VARISTOR.....	7
4.2	VARACTOR (OR VARICAP) DIODE	7
4.3	VARICAP DIODE FOR HARMONIC MULTIPLICATION	7
4.4	SCHOTTKY DIODE.....	7
4.5	GUNN DIODE	8
4.6	QCL AS LOCAL OSCILLATOR	9
5	Heterodyne instrument concept	9
5.1	GENERIC SCHEME OF AN HETERODYNE RADIOMETER	9
5.2	HETERODYNE INSTRUMENT MODELS	10
5.2.1	<i>Bandwidth and resolution</i>	10
5.2.2	<i>Hypothesis with fixed LO and wide SSB</i>	11
5.2.3	<i>Hypothesis with fixed LO and narrow DSB</i>	13
5.2.4	<i>Hypothesis with variable LO and narrow DSB</i>	14
5.2.5	<i>Resolution and noise of a multiplication chain</i>	15
6	Instrument design	16
6.1	INSTRUMENT SCHEME.....	16
6.2	INSTRUMENT MINIMAL COMPONENTS.....	17
6.3	INPUT POWER.....	17
6.4	NOISE.....	19
6.5	MIXER NOISE	20
6.6	ANTENNA	21
6.6.1	<i>Directivity</i>	21
6.6.2	<i>Efficiency</i>	21
6.6.3	<i>Gain</i>	21
6.6.4	<i>From antenna gain to transmitted signal efficiency</i>	22
6.7	REAL INSTRUMENT LO + MIXER	22
6.7.1	<i>Chain 0 - 2695 - 2705 GHz</i>	22
6.7.2	<i>Chain 1 - 500 - 660 GHz</i>	25
6.7.3	<i>Chain 2 - 660 - 740 GHz</i>	28
6.7.4	<i>Chain 3 - 795 - 1100 GHz</i>	32
6.8	CALCULATION OF SNR FOR THE GENERIC CHAIN	36
6.8.1	<i>Chain 0</i>	40
6.8.2	<i>Chain 1</i>	41
6.8.3	<i>Chain 2</i>	43
6.8.4	<i>Chain 3</i>	44
6.9	SIGNAL CONDITIONING ON DETECTION CHAIN.....	45
7	Conclusions.....	47

1 Introduction

1.1 THz frequency range

This report presents an analysis of the atmospheric characteristics in the terahertz spectral region (frequencies from 300 GHz to 10 THz, wavelengths from 30 μm to 1 mm, see Fig. 1.1), with particular attention in the range 1 to 5 THz. This interval is the spectral range of interest in the framework of DIAST project.

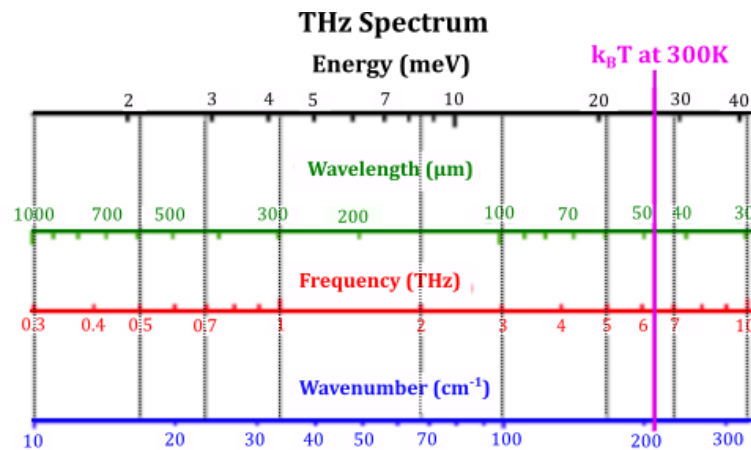

Fig. 1.1: Different scales and units.

Historically the THz spectral interval has been characterized by a relative lack of convenient radiation sources, detectors and transmission technology (Fig. 1.2).

This document considers the designs of different spectroradiometers and the simulation of their instrumental responses. The simulations take into account the scenarios presented in the document: "REPORT - DIAST Project 1 - Typical atmospheric scenarios in the 0.6 - 5 THz wavelength range", in which the atmospheres have been chosen to be representative of a realistic working scenario in different acquisition geometries, taking into account the typical gaseous components and pollutants of terrestrial atmosphere.

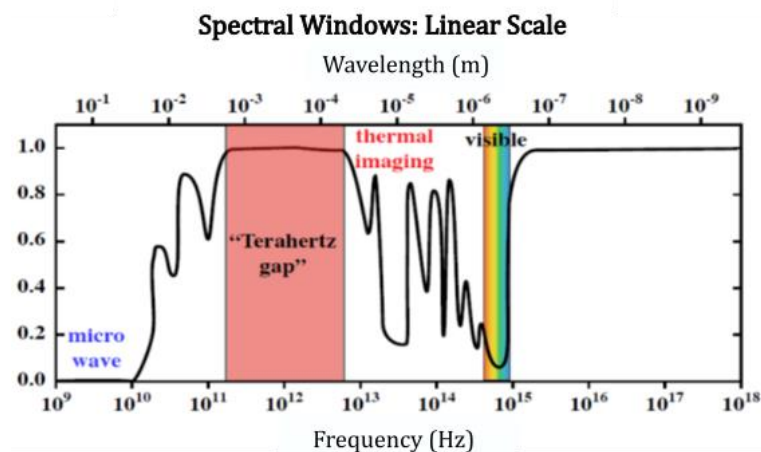

Fig. 1.2: Absorption spectral windows.

2 Heterodyne detection

2.1 Heterodyne principle

Heterodyne detection is a method of detecting radiation by non-linear mixing with radiation of a reference frequency.

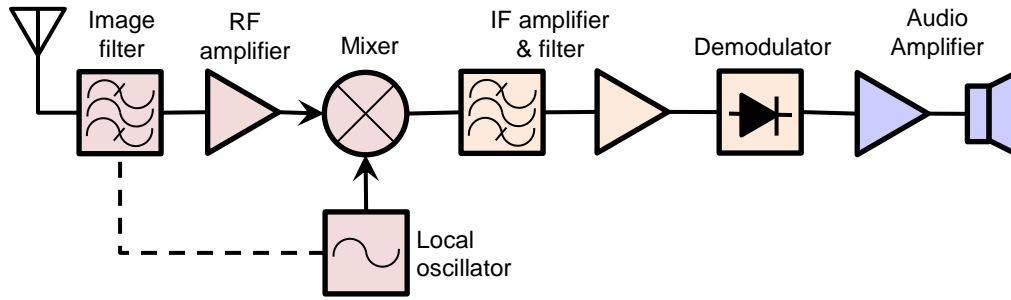

Fig. 2.1: (Super) heterodyne modulation diagram (image re-arranged from https://en.wikipedia.org/wiki/RF_front_end).

The reference radiation is known as the local oscillator. The signal and the local oscillator are superimposed at a mixer. The mixer, which is commonly a (photo-)diode, has a non-linear response to the amplitude, that is, at least part of the output is proportional to the square of the input.

The received signal is represented as:

$$E_{sig} \cos(\omega_{sig}t + \varphi)$$

and that of the local oscillator can be represented as

$$E_{LO} \cos(\omega_{LO}t).$$

For simplicity, assume that the output I of the detector is proportional to the square of the amplitude:

$$\begin{aligned} I &\propto [E_{sig} \cos(\omega_{sig}t + \varphi) + E_{LO} \cos(\omega_{LO}t)]^2 = \\ &= \frac{E_{sig}^2}{2} [1 + \cos(2\omega_{sig}t + 2\varphi)] + \frac{E_{LO}^2}{2} [1 + \cos(2\omega_{LO}t)] + \\ &+ E_{sig}E_{LO} \{ \cos[(\omega_{sig} + \omega_{LO})t + \varphi] + \cos[(\omega_{sig} - \omega_{LO})t + \varphi] \} = \\ &= \underbrace{\frac{E_{sig}^2 + E_{LO}^2}{2}}_{\text{constant component}} + \underbrace{\frac{E_{sig}^2}{2} \cos(2\omega_{sig}t + 2\varphi) + \frac{E_{LO}^2}{2} \cos(2\omega_{LO}t) + E_{sig}E_{LO} \cos[(\omega_{sig} + \omega_{LO})t + \varphi]}_{\text{high frequency component}} \\ &+ \underbrace{E_{sig}E_{LO} \cos[(\omega_{sig} - \omega_{LO})t + \varphi]}_{\text{beat (low frequency) component}} \end{aligned}$$

2.2 Image frequency

In heterodyne receivers, an image frequency is an undesired input frequency equal to the station frequency plus twice the intermediate frequency. The image frequency results in two stations being received at the same time, thus producing interference. Image frequencies can be eliminated by sufficient attenuation on the incoming signal by the RF amplifier filter of the superheterodyne receiver:

$$f_{img} = \begin{cases} f + 2f_{IF} & \text{if } f_{LO} > f \text{ (high side injection)} \\ f - 2f_{IF} & \text{if } f_{LO} < f \text{ (low side injection)} \end{cases}$$

Sensitivity to the image frequency can be minimised only by a filter that precedes the mixer or a more complex mixer circuit that suppresses the image, accomplished by a bandpass filter in the between the antenna and the mixer. In many tuneable receivers, the bandpass filter is tuned in tandem with the local oscillator.

Since the frequency separation between the bandpass and the image frequency is $2f_{IF}$, a higher intermediate frequency improves image rejection.

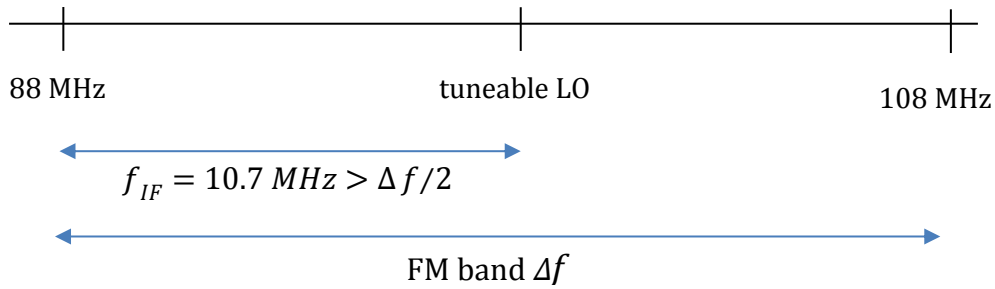

Fig. 2.2: FM band tuning using heterodyne principle: $f_{IF} > \Delta f/2$ ensures no image frequency inside FM band.

Reason to use intermediate frequency (IF):

- at very high (gigahertz) frequencies, signal processing circuitry performs poorly;
- active devices such as transistors cannot deliver much amplification (gain);
- ordinary circuits using capacitors and inductors must be replaced with cumbersome high frequency techniques such as striplines and waveguides.

A dual-conversion receiver may also have two intermediate frequencies, a higher one to improve image rejection and a second, lower one, for desired selectivity.

2.3 Mixer

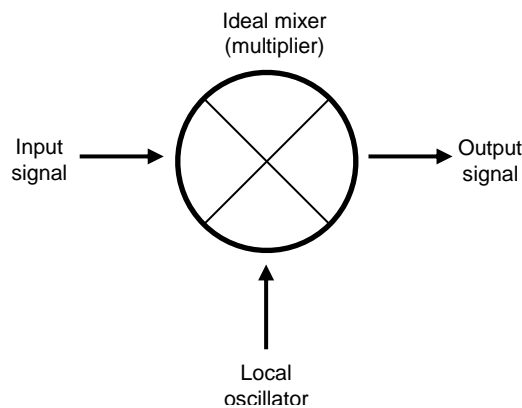

Fig. 2.3: Mixer diagram.

A mixer or frequency mixer is a nonlinear electrical circuit that creates new frequencies from two signals applied to it. In its most common application, two signals at frequencies f_1 and f_2 are applied to a mixer, and it produces new signals at the sum $f_1 + f_2$ and difference $f_1 - f_2$ of the original frequencies.

Mixers are widely used to shift signals from one frequency range to another, a process known as heterodyning, for convenience in transmission or further signal processing. For example, a key component of a superheterodyne receiver is a mixer used to move received signals to a common intermediate frequency.

A diode can be used to create a simple unbalanced mixer: The current I through an ideal diode as a function of the voltage V across it is given by:

$$I = I_s \left(e^{\frac{qV_D}{nkT}} - 1 \right)$$

where what is important is that V appears in e 's exponent. The exponential can be expanded as:

$$e^x = \sum_{n=0}^{\infty} \frac{x^n}{n!}$$

and can be approximated for small x (that is, small voltages) by the first few terms of that series:

$$e^x - 1 \approx x + \frac{x^2}{2}$$

3 THz sources

THz sources greater than 1 THz are usually transistors, Gunn oscillators or Schottky diode multipliers: 1 THz \rightarrow power < 1mW (for example, 50 μ W at 1.8 THz for a Schottky multiplier chain).

The photonic approaches to direct terahertz generation are limited by the lack of appropriate materials with sufficiently small bandgaps (for example the longest wavelength lead salt laser diodes do not extend below 15 THz).

Common methods for generating radiation above 1 THz are:

- down-conversion from the visible regime by using nonlinear or photoconductive effects,
- multiplication up from the millimetre-wave regime,
- direct generation, such as with optically pumped molecular gas lasers or free-electron lasers.

3.1 FIR Lasers

Far InfraRed or THz lasers consist of a long (1–3 meters) waveguide filled with gaseous organic molecules, usually optically pumped. They are highly inefficient, often require helium cooling, high magnetic fields, and/or are only line tuneable.

3.2 QC Lasers

- Amplification by means of stimulated emission of electrons between quantized sub bands in two-dimensional quantum wells that could be obtained by growing atomically sharp semiconductor heterostructures.
- Quantum Cascade (QC) lasers: At present, spectral coverage from 0.84–5.0 THz, at maximum temperatures up to 169 K, pulsed, and 117 K, c.w., and output powers of up to 250 mW, pulsed, and 130 mW, c.w.

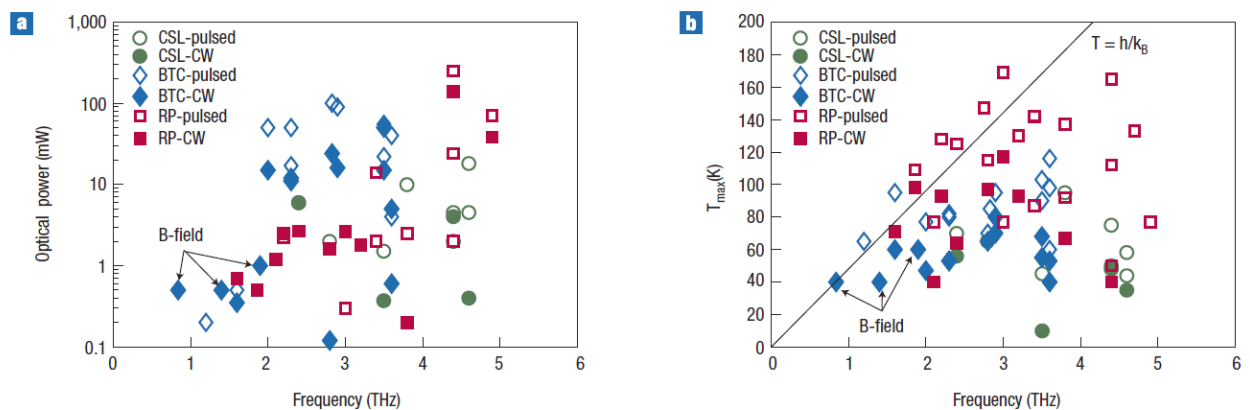

Fig. 3.1: Survey of the reported peak performance of terahertz QC lasers. a, Peak optical power and, b, peak operating temperatures are shown as a function of lasing frequency. Data are sorted by pulsed or c.w. performance and active-region design: resonant-phonon (RP), bound-to-continuum (BTC) or chirped superlattice (CSL) active region. Several of the low-frequency designs operate with the assistance of a magnetic field (B-field). From W. S Williams, “Terahertz quantum-cascade lasers”.

3.3 Semiconductor Terahertz GaSe, ZnTe Crystals

ZnTe (Zinc Telluride) crystals are used for THz generation by optical rectification process. Optical rectification is a difference frequency generation in media with large second order susceptibility.

4 THZ local oscillator

Local oscillators can be described by the following scheme:

- Up to 150 GHz → fundamental (second harmonic) sources such as Gunn oscillators.
- Up to 600 GHz → Schottky varactor multipliers
- In the 1 THz region → efficiency and output power of the varactor/varistor multipliers becomes very low.

4.1 Varistor

A varistor is an electronic component with an electrical resistance that varies with the applied voltage.[1] Also known as a voltage-dependent resistor (VDR), it has a nonlinear, non-ohmic current-voltage characteristic that is similar to that of a diode. In contrast to a diode however, it has the same characteristic for both directions of traversing current. At low voltage it has a high electrical resistance which decreases as the voltage is raised.

4.2 Varactor (or varicap) diode

A varactor (or varicap) diode is a **variable capacitance diode**, designed to exploit the voltage-dependent capacitance of a reversed-biased p-n junction.

4.3 Varicap diode for harmonic multiplication

A large signal amplitude AC voltage is applied across a varicap to deliberately vary the capacitance at signal rate and generate higher harmonics, which are filtered off and used further down the signal chain. This happens because when the capacitance of a charged capacitor is reduced, the voltage across it is increased which, in turn further reduces the capacitance if it is a varicap.

The energy stored on a charged capacitor is given by $E = CV^2/2$ thus if E is constant, but C is reduced then V must increase, thus if a sine wave of sufficient amplitude is applied across a varicap it gets "peaked" into a more triangular shape, and odd harmonics are generated.

This was one early method used to generate microwave frequencies of moderate power, 1–2 GHz at 1–5 watts, from about 20 watts at a frequency of 3–400 MHz before adequate transistors had been developed to operate at this higher frequency. This technique is still used to generate much higher frequencies, in the 100 GHz–1THz range, where even the fastest GaAs transistors are still inadequate.

4.4 Schottky diode

A Schottky diode is a semiconductor diode with a low forward voltage drop (and a very fast switching time). This lower voltage drop provides better system efficiency and higher switching speed. In a Schottky diode, a semiconductor-metal junction is formed between a semiconductor and a metal, thus creating a Schottky barrier. The N-type semiconductor acts as the cathode and the metal side acts as the anode of the diode. This Schottky barrier results in both a low forward voltage drop and very fast switching.

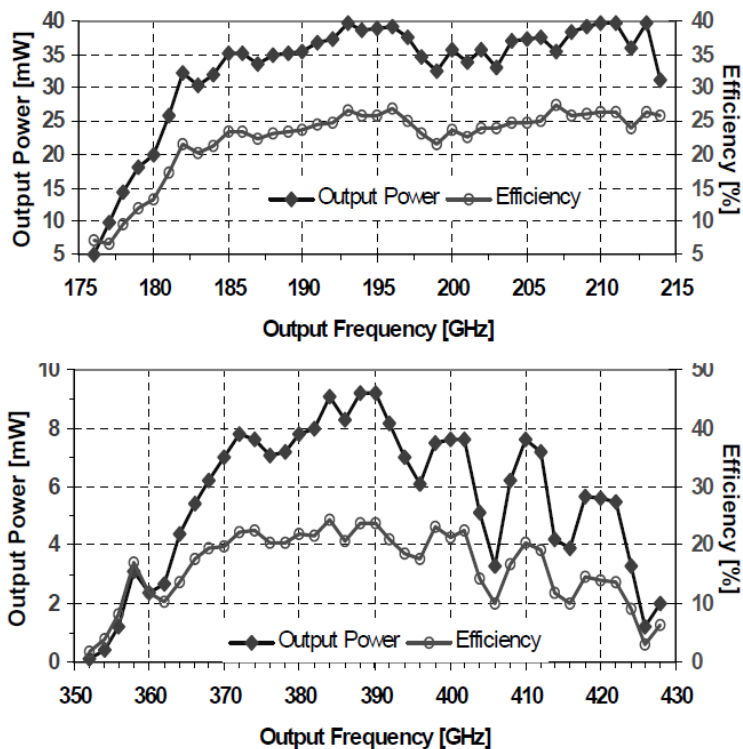

Fig. 4.1: Performance of planar Schottky diode varactors “membrane” devices at room temperature. Efficiency decrease with frequency. From Mehdi I. et al.: "THz Local Oscillator Sources".

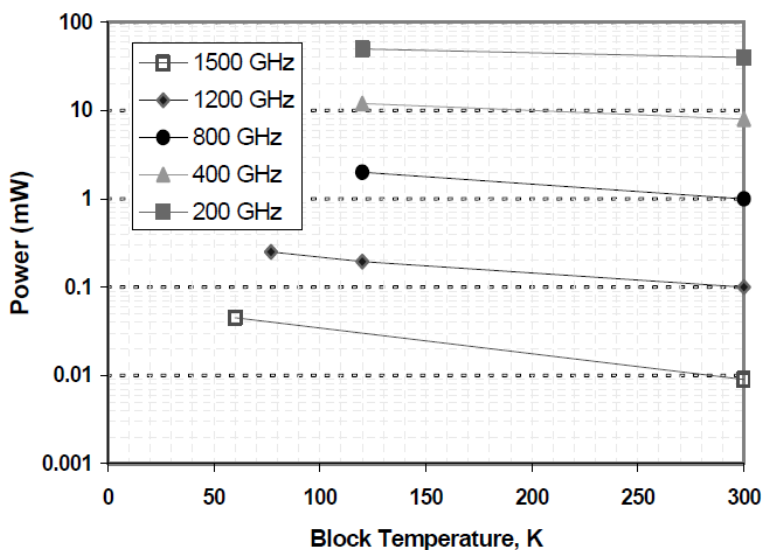

Fig. 4.2: Multiplier chain of L.O. as a function of temperature. From Mehdi I. et al.: "THz Local Oscillator Sources".

4.5 Gunn diode

A Gunn diode has a region of negative differential resistance in its current-voltage characteristic curve, in which an increase of applied voltage causes a decrease in current. This property allows it to amplify the input signal, or to become unstable (and oscillate) when it is biased with a DC voltage.

Because of their high frequency capability, Gunn diodes are used at microwave frequencies. They can produce some of the highest output power of any semiconductor devices at these frequencies.

4.6 QCL as local oscillator

Quantum cascade lasers (QCLs) are semiconductor lasers that emit in the mid- to far-infrared portion of the electromagnetic spectrum to THz frequencies.

In the following lines, the characteristics of the QCL used in the DIAST project are presented:

Laser name	Laser 2.7	Laser 1.8
Laser type	QCL	QCL
Central frequency (GHz)	2700 (single mode)	1500 – 1800
Working mode	CW	pulsed or CW
FWHM (GHz)	1.0	-
Average power	-	5 mW
Power @ 10K	20 mW	-
Power @ 50K	5 mW	-
Working temperature (K)	10 to 70	10 – 40
Voltage (V)	4 to 5	-
Current (mA)	~ 100	-
Polarization	negative	negative

Laser spatial occupation

Laser name	Laser 2.7	Laser 1.8
Laser length (mm)	2.0	-
Laser size (mm)	0.15	-
Laser width (mm)	0.01	-

Laser optical characteristics

Laser name	Laser 2.7	Laser 1.8
Beam divergence (deg)	30 – 35 (on both axis)	-
Beam FWHM (μm)	150	-

5 Heterodyne instrument concept

5.1 Generic scheme of an heterodyne radiometer

Next figure shows the instrument concept scheme, together with the budgetary price of the different components (prices from VDI customer service, requested by email in January 2016).

Prices for on-the-shelf tools are in the order of 10000 ÷ 100000 \$.

The section 0 reports some commercial devices datasheets and main information.

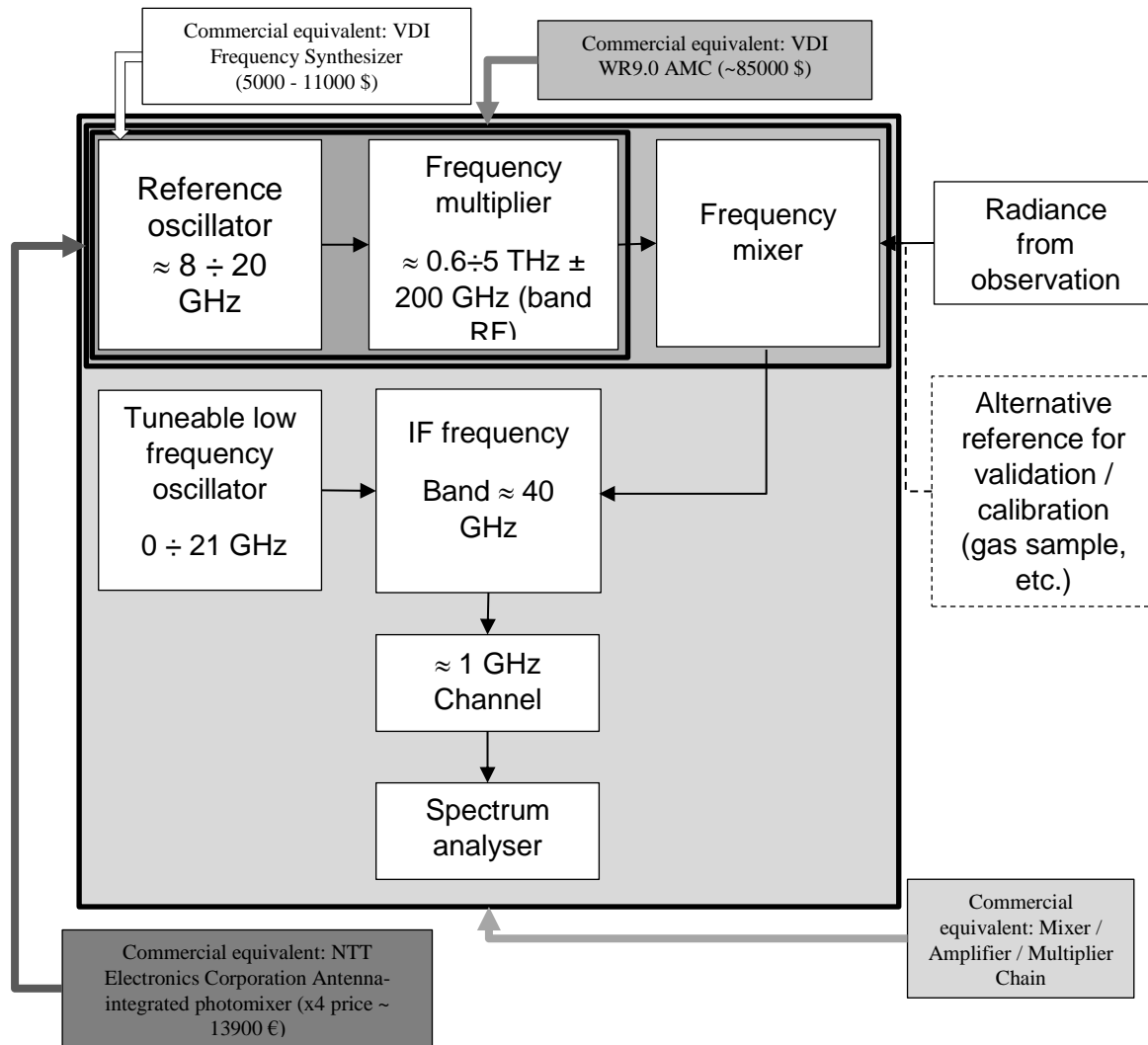

Fig. 5.1: Heterodyne instrument scheme, together with budgetary price of different components.

5.2 Heterodyne instrument models

5.2.1 Bandwidth and resolution

Hypothesis for selecting bandwidth and resolution:

- Fixed or partially tuneable band.
- Between 0.6 THz and 5 THz.
- State of the art:
 - Total band: 40 GHz \rightarrow 1.3 cm⁻¹ @ 1 THz
 - $\Delta\lambda = 2$ GHz \rightarrow 0.06 cm⁻¹ @ 1THz \rightarrow 0.6 μ m @ 1THz.
- Worst case scenario:
 - Total band: 200GHz \rightarrow 6 cm⁻¹.
 - $\Delta\lambda = 10$ GHz \rightarrow 0.3 cm⁻¹ @ 1THz \rightarrow 3.0 μ m @ 1THz.

Considerations:

1. With non-fixed (tuneable) LO, using a narrow IF band is an advantage due to the fact that IF filters will work at low frequency (\sim GHz). The system acquires a signal in Double Side Band (DSB), see Fig. 5.2.

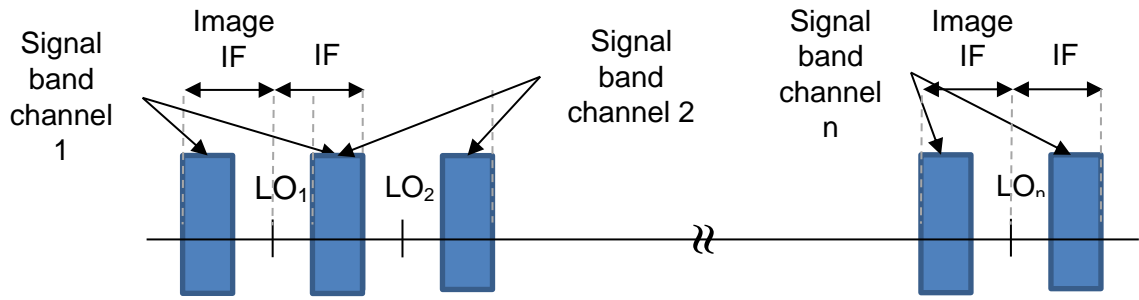

Fig. 5.2: non-fixed (tuneable) LO, using a narrow IF band. The system acquires a signal in DSB.

2. With fixed LO (NON tuneable), the RF band is scan by choosing an IF band $> RF/2$ band (condition of no image frequency). A large RF implies a large IF band, so a second heterodyne system is needed for scanning IF, see Fig. 5.3.

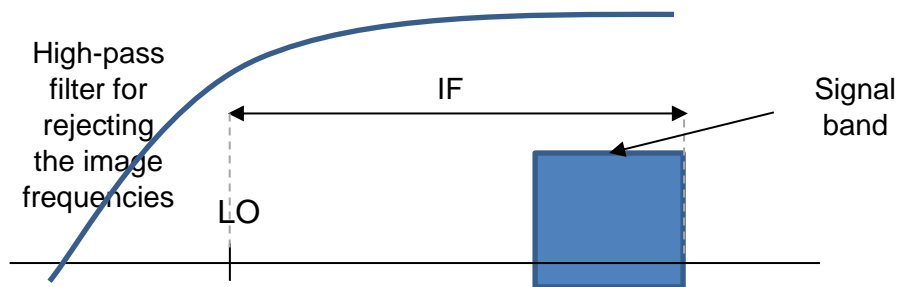

Fig. 5.3: Fixed LO and large IF requiring a second heterodyne system for scanning the signal spectrum.

3. With fixed LO (NON-tuneable), and narrow IF band, the analysis is restricted to the spectral range around LO (and the system acquires in DSB mode). Case of Fig. 5.2 with a single channel.

		Start frequency	End frequency	Delta frequency
case1 (1550 nm laser as LO)	LO (GHz)	400	1200	
case2 (1550 nm laser as LO)	LO (GHz)	200	1800	
case3 (QC laser as LO)	LO (GHz)	~1500; ~1800		
case1 (1550 nm laser as LO)	RF (GHz)	1000	1800	800
case2 (1550 nm laser as LO)	RF (GHz)	1000	2200	1200
case3 (QC laser as LO)	RF (GHz)	1200	2200	1000
case1 (1550 nm laser as LO)	IF (GHz)	400	600	200
case2 (1550 nm laser as LO)	IF (GHz)	600	800	200
case3 (QC laser as LO)	IF (GHz)	500	505	5

Tab. 5.1: Frequency range using different local oscillator. Comparison with case 3 (QC laser), with a narrower IF band (no need for a further heterodyne stage).

5.2.2 Hypothesis with fixed LO and wide SSB

- QC laser @ 1500GHz.
- LSB of approximately 500 GHz \rightarrow band of interest \sim 200GHz (case 2 of par.5.2).

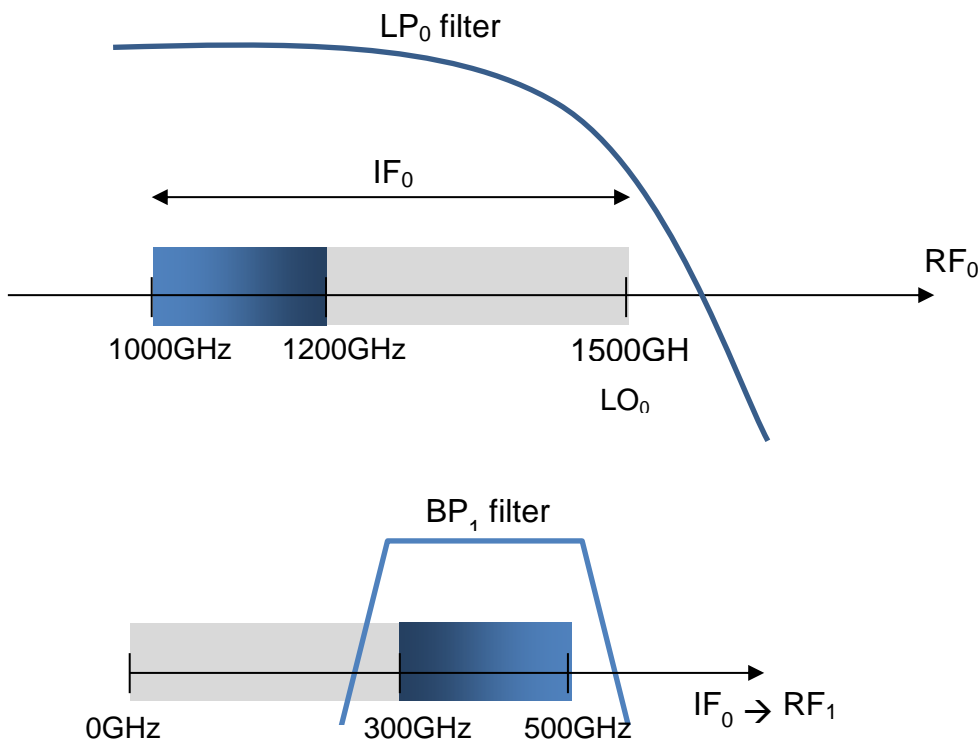

Fig. 5.4: Stage 0: We use a low-pass filter LP₀ for selecting frequency below 1500 GHz. Using the fixed local oscillator LO₀ we take the intermediate frequency IF₀ (in grey) at the lower side band (LSB). Note that the signal is acquired mirrored along frequency axis. A band pass filter BP₁ selects only the band of interest (200 GHz) on the IF₀ band (in blue). Note that replacing the low-pass filter LP₀ with a corresponding high-pass filter, the IF₀ band would be between 1500 and 2000 GHz (with a channel of interest between 1800 – 2000 GHz).

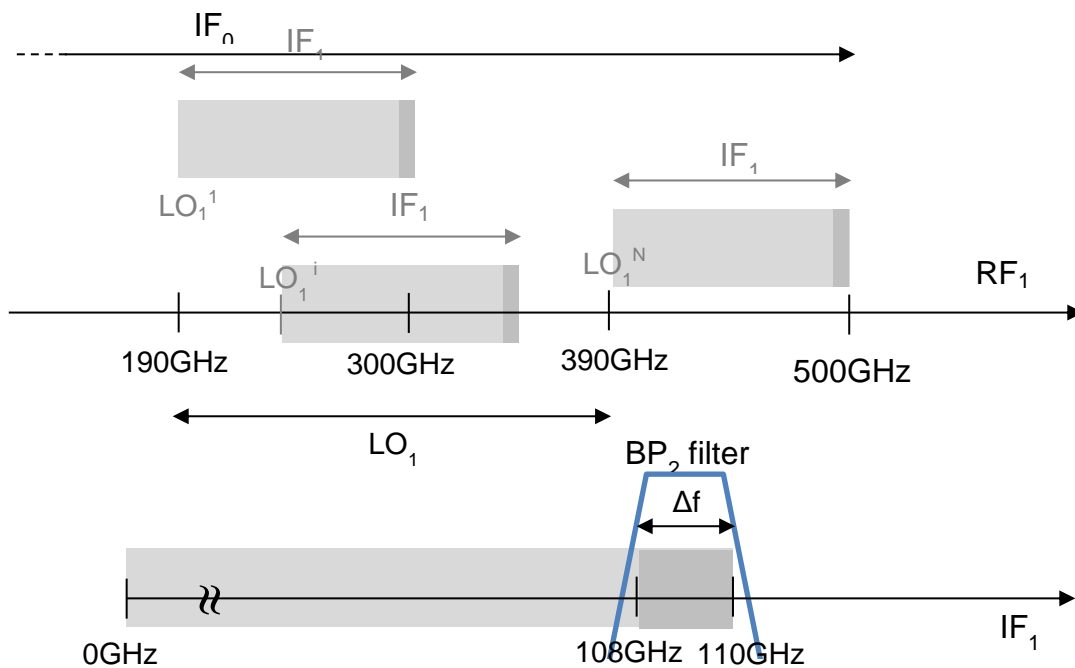

Fig. 5.5: Stage 1: A variable local oscillator LO₁ can be varied with step $\Delta f \approx 2$ GHz between 190 GHz (LO₁¹) and 390 GHz (LO₁^N) allowing the selection of an intermediate frequency band IF₁ 110 GHz wide (greater than one half of the filtered band of interest IF₀ i.e. RF₁ to avoid image frequencies). A narrow band pass filter BP₂ allows the selection of the i-th channel with resolution Δf .

Notes:

- Large (and tuneable) band offered by the second stage.
- Signal acquired in single side band modality, i.e. direct correspondence between real spectrum and observed signal.
- Need of the second heterodyne stage.
- Image band advantage: replacing the low-pass filter LP_0 with a corresponding high-pass filter, the IF_0 band is replaced by the band 1500 – 2000 GHz with a channel of interest between 1800 – 2000 GHz. In this way **the same instrument would cover a double wavelength interval**.
- **Using different LOs increases the wavelength range** of the instrument (i.e. a second LO centred at 1700 would allow acquiring a further channel of interest between 1200 and 1400 GHz using a low-pass filter and between 2000 and 2200 GHz using a high-pass filter).

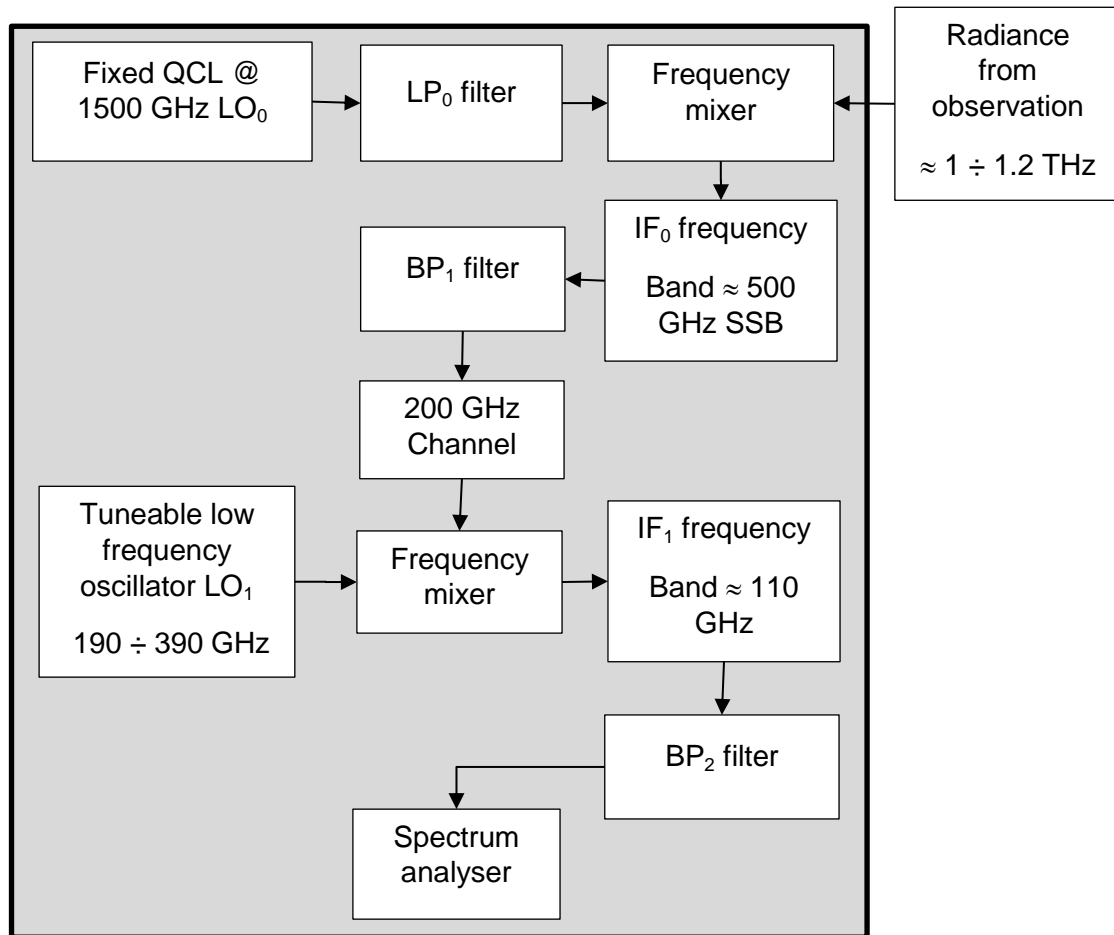

Fig. 5.6: Instrument scheme.

5.2.3 Hypothesis with fixed LO and narrow DSB

- QC laser @ 1500GHz.
- DSB of approximately 10 GHz → band of interest ~ 2 GHz (case 1 of par.5.2).

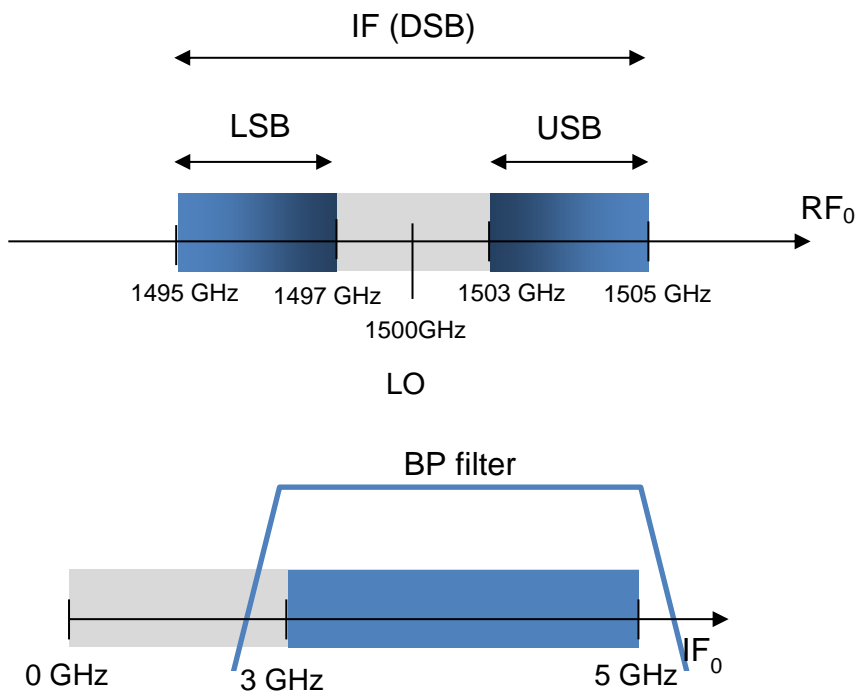

Fig. 5.7: Only the narrow band around the fixed local oscillator LO is observed. The intermediate frequency IF can in principle be directly acquired by a digital spectrometer. The advantage is the lack of second stage described in par. 5.2.2.

Notes:

- Narrow (and non-tuneable) band due to the fixed LO.
- Signal acquired in double side band modality, i.e. convolution of image frequencies of both LSB and USB bands.
- Absence of second stage: IF can be acquired in radio frequencies (i.e. more compact design).

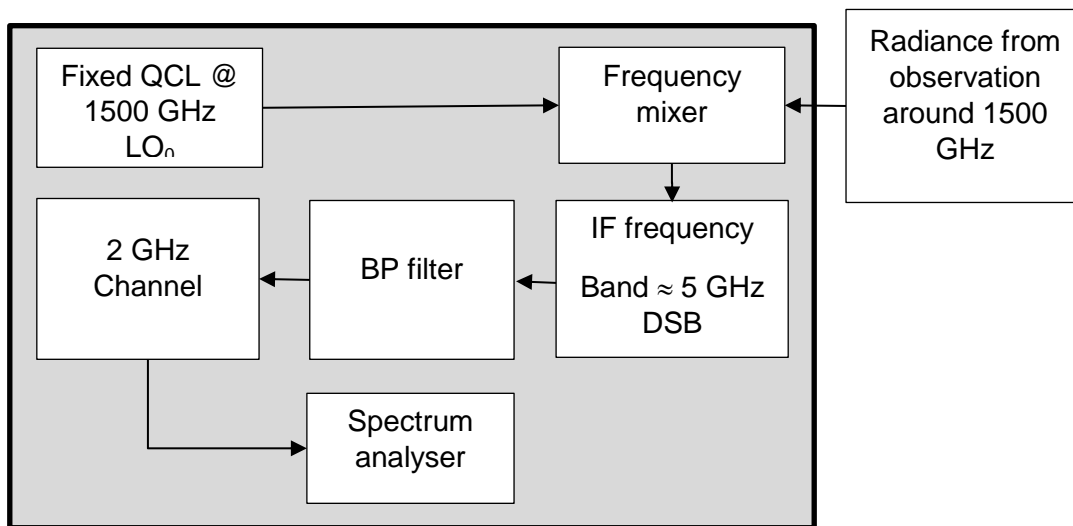

Fig. 5.8: instrument scheme.

5.2.4 Hypothesis with variable LO and narrow DSB

- Variable LO with step $\sim \Delta f = 2.5\text{ GHz}$.
- DSB of approximately $7.5\text{ GHz} \rightarrow$ band of interest $\sim 2.5\text{ GHz}$ (case 3 of par.5.2).
- Keeping $IF = 3\text{ LSB} = 3\text{ USB}$ and varying the LO frequency with step $\sim \Delta f = IF/3 = USB = LSB$ ensures a continuous cover of the spectrum.

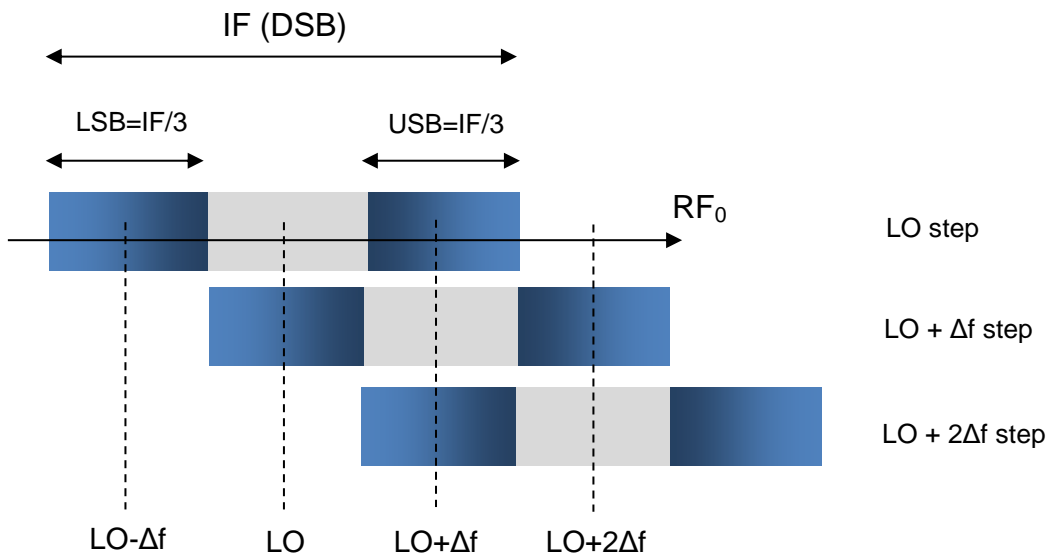

Fig. 5.9: Only the narrow band around the fixed local oscillator LO is observed. The intermediate frequency IF can in principle be directly acquired by a digital spectrometer. The advantage is the lack of second stage described in par. 5.2.2.

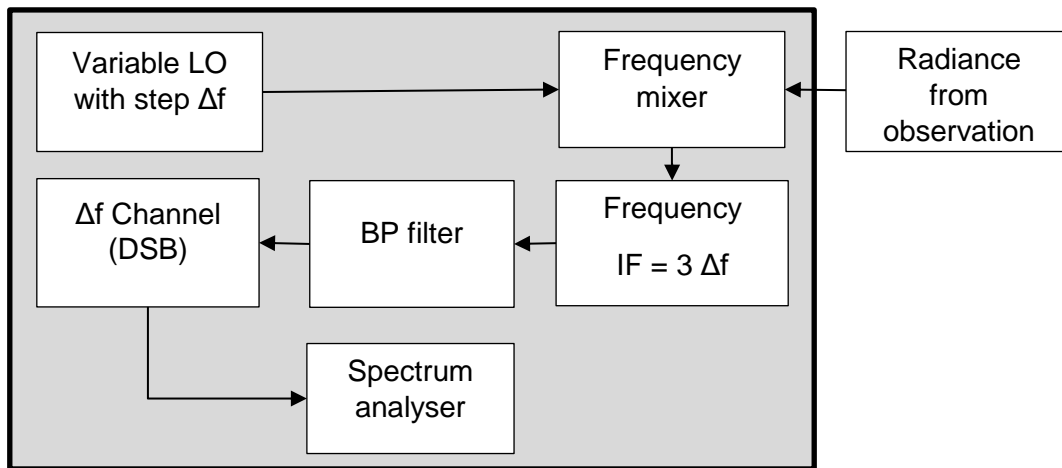

Fig. 5.10: instrument scheme.

Notes:

- Wide band on the entire LO range with resolution Δf (Δf band can also be sampled with a spectrum analyser with narrower resolution).
- Signal acquired in double side band modality (i.e. convolution of image frequencies of both LSB and USB bands) but DSB and LSB can be software-processed to reconstruct the real (i.e. non-DSB) signal.
- Compact design (signal can be integrated in the band Δf or acquired with better resolution with a spectrum analyser).

5.2.5 Resolution and noise of a multiplication chain

When using frequency multipliers, the phase noise of the base oscillator is increased by $20 \cdot \log(N)$, where N is multiplication factor. In addition, the frequency resolution of the base oscillator is multiplied by the multiplication factor.

Example:

- 20Hz frequency resolution with a base oscillator at ~15GHz,
- use an x70 multiplication chain.

Then:

- 1.40kHz (=20Hz*70) frequency resolution at ~1THz.

Considering a base oscillator with -95dBc/Hz phase noise at 1kHz offset at a base frequency of ~15GHz and use x70 multiplier chain, we have a $20\log(70) \cong 37\text{dB}$ increase in the phase noise at ~1THz, or ~-58 dBc/Hz at a 1kHz offset.

6 Instrument design

6.1 Instrument scheme

The instrument has characteristics in between the logical schemes introduced in par. 5.2.2 and 5.2.4.

The requirements establish an LO provided by a QCL. Such a device offers high input power but limited (or absent) tuning capabilities. For taking into account also the possibility that such a device is not (entirely) in our availability, we provide an alternative scheme without the use of the QCL. The design of the chain has been performed by trying to maximize the common blocks between the two instrument concepts.

The scheme (Fig. 6.1) on the left provides the LO signal directly by the QCL through a fundamental mixer. On the opposite side, the alternative solution provides an LO signal by frequency multiplication from a low frequency signal generator applied to a subharmonic mixer, i.e. a device in which the final LO frequency is obtained by summing the input LO harmonics at lower (typically half) frequency (e.g. the WR-0.65 (1.1-1.7 THz) from VDI).

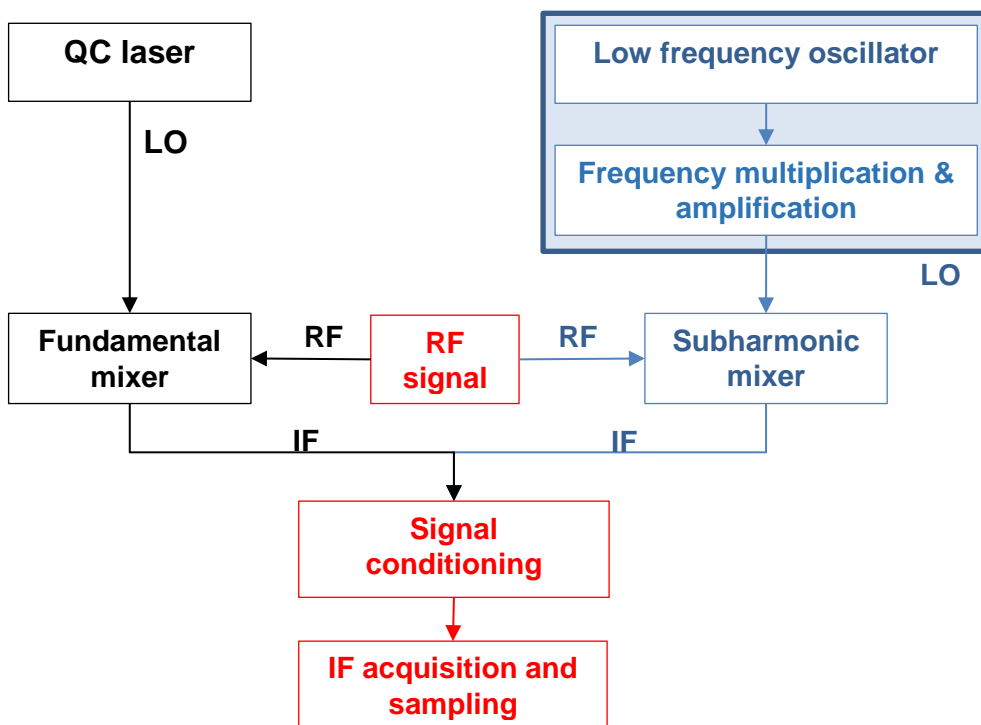

Fig. 6.1: Basic instrument chain. The black chain on the left shows the use of a QCL for directly generating an LO signal to be send to a fundamental mixer; The blue part of the chain on the right is alternative to the QCL and uses a low frequency oscillator signal for generating an high frequency LO by harmonic multiplication using a subharmonic mixer. The red block is the common part of the chain and is used for signal filtering, amplifying and finally for acquisition and sampling.

The IF signal is elaborated by a (common) signal conditioning block, made of an amplification chain and the corresponding filters, allowing the signal sampling and final acquisition.

A further frequency shift (i.e. a further heterodyne stage) can be insert in the signal conditioning block in case the IF signal from the mixer has harmonics too high for direct acquisition by a spectrum analyser. In this case, a second heterodyne stage would increase the sampling resolution of the final data.

The characterization of each block of the chain is provided in the following paragraphs.

6.2 Instrument minimal components

Minimal components for the realization of a heterodyne receiver based on a tuneable LO + a subharmonic mixer):

1. Horn antenna (or similar device for detection);
2. Local oscillator (i.e. tens – hundreds of GHz);
3. Subharmonic mixer;
4. Signal conditioning (amplification/filter chain).
5. Spectrum analyser or similar component (i.e. second heterodyne stage for single band integration and sampling).

Minimal components for the realization of a heterodyne receiver based on a (non) tuneable QLC laser + fundamental mixer:

1. Quasi-optics for collecting signal + laser;
2. Quantum cascade laser;
3. Fundamental mixer (**NOTE: to be customized**);
4. Signal conditioning (amplification/filter chain).
5. Spectrum analyser or similar component (i.e. second heterodyne stage for single band integration and sampling).

Note that points 4-5 are shared between the two lists.

We underline that technological difficulties arise working with high frequencies. Our advice is **to maintain the frequency range below 1.5 THz** for avoiding technical limitation (and lack of on-the-shelf components) and reducing the price of the components.

6.3 Input power

From HITRAN simulation we establish a typical signal of $1.E-09 \text{ W cm}^{-2} \text{ sr}^{-1} (\text{cm}^{-1})^{-1}$ to be detected with *minimal* SNR =1.

The typical background value can be determine from blackbody equivalent emission (Fig. 6.2).

The signal range has values that can be approximated, for a standard USA atmosphere at sea level, with the emission of a blackbody at lower temperature with absorption features (mainly due to H₂O). The value range is represented in Fig. 6.4.

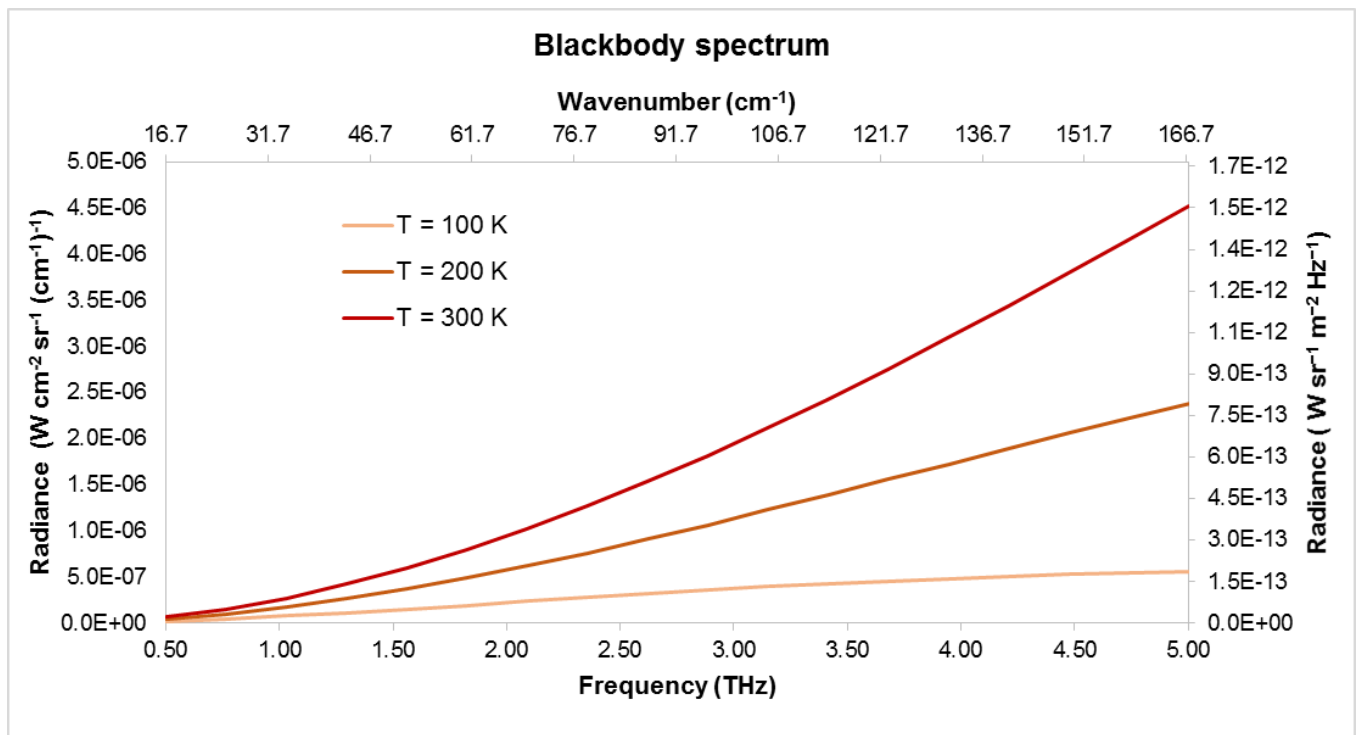

Fig. 6.2: Blackbody spectra at different temperatures.

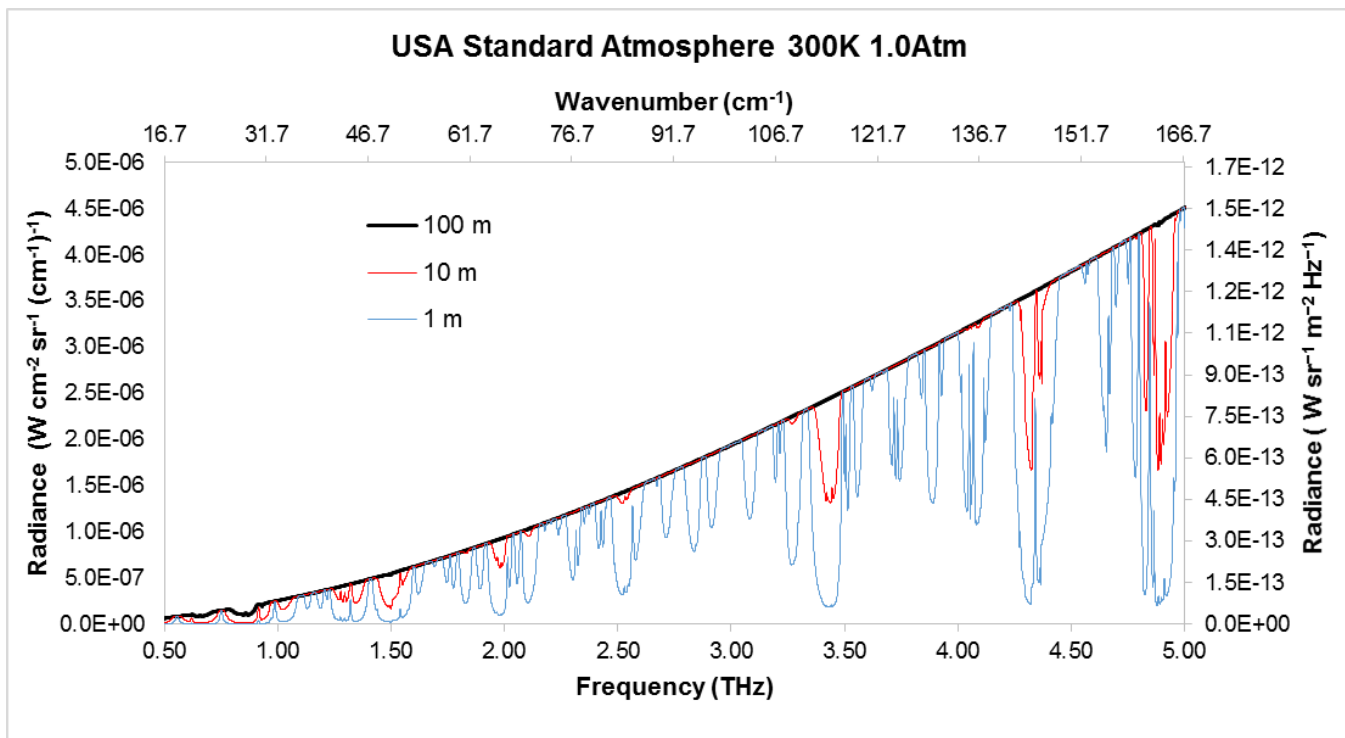

Fig. 6.3: USA Standard atmosphere spectra at 300K temperature and 1.0 Atm pressure (representative of atmosphere conditions at ground level) for different path lengths.

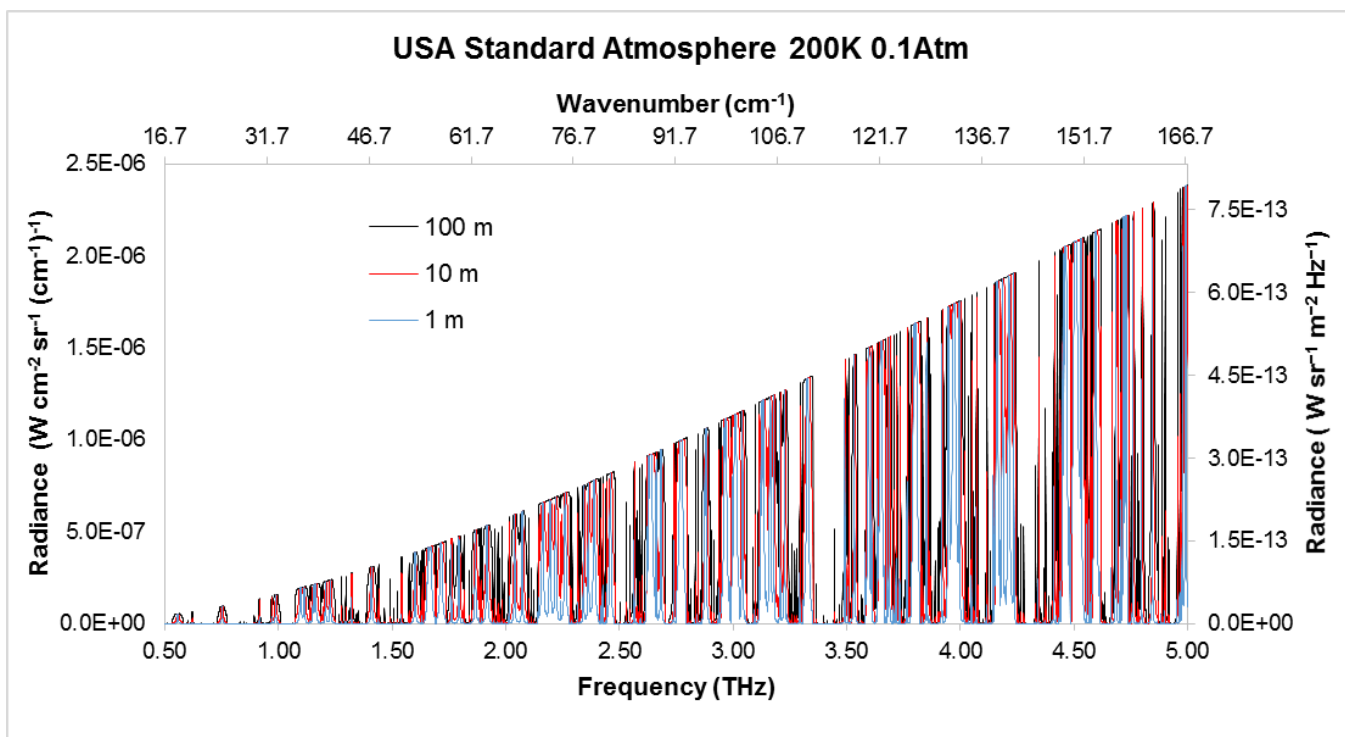

Fig. 6.4: USA Standard atmosphere spectra at 200K temperature and 0.1 Atm pressure (representative of high troposphere conditions) for different path lengths.

6.4 Noise

Antenna's noise power is seen by the detection system as if originating from a resistor, R_A (antenna radiation resistance) at temperature T_A (the temperature the antenna "sees" through its power pattern, NOT the actual physical temperature of the antenna).

We define the flux density at antenna terminals (in $W m^{-2} Hz^{-1}$) as:

$$S_v^0 = \frac{2kT_A}{A}$$

with T_A being the antenna equivalent temperature (K), A the effective aperture of antenna (m^2), and k the Boltzmann's constant ($1.38 \times 10^{-23} J K^{-1}$).

The total system noise temperature, T_{sys} , referenced to the antenna terminals is:

$$T_{sys} = T_A + T_{RX}$$

where T_{RX} is the equivalent black-body receiver noise temperature (K).

The purpose of a receiver system is to detect the observed source flux density, S_v^0 , to a level where it can be detected. Unwanted noise power must be reduced. The value of the instantaneous noise flux of the detection system S_v^{sys} is almost always much greater than the signal of the source of interest S_v^0 . For allowing detection (SNR at least 1) the condition to be satisfied is that ΔS_v^{RMS} (the RMS value of S_v^{sys}) is:

$$\Delta S_v^{RMS} \leq S_v^0$$

ΔS_v^{RMS} is related to the system noise flux S_v^{sys} by the radiometer equation:

$$\Delta S_v^{RMS} = \frac{K_s S_v^{sys}}{\sqrt{\Delta\tau_{int} \Delta\nu}} = \frac{2k}{A} \frac{K_s T_{sys}}{\sqrt{\Delta\tau_{int} \Delta\nu}}$$

with K_s dimensionless sensitivity constant (~ 1 to 2 depending on receiver and detection strategy, e.g. $K_s = 2$ in comparing background and background + signal), $\Delta\tau_{int}$ the integration time and $\Delta\nu$ the frequency bandwidth (i.e. resolution in Hz). We can define the RMS noise level of the system also in terms of RMS noise temperature (K) as (Central Limit Theorem):

$$\Delta T_{RMS} = \frac{K_s T_{sys}}{\sqrt{\Delta\tau_{int} \Delta\nu}}$$

ΔT_{RMS} can also be seen as the standard deviation in the Gaussian noise floor equal to 1/3 peak to peak noise floor temperature.

To detect a source at temperature T_v^s Must be $T_v^s \approx \Delta T_{RMS}$ for having at least SNR = 1.

The quantity T_{sys} is the equivalent blackbody noise temperature of the receiver system, i.e. the equivalent noise injected into the observed signal by the receiver. The greater the value of T_{sys} , the longer you will need to integrate to reach the target value of ΔT_{RMS} , as long as the noise remains uncorrelated (white noise, usually restricted to between ~ 10 and 30 s before it stops integrating down), i.e., to detect a source of temperature T_v^s we must integrate until T_v^s is above the noise floor:

$$SNR = \frac{T_v^s}{\Delta T_{RMS}} > 1$$

where

$$T_v^s(K) = \frac{W_v^s(W)}{k (WHz^{-1}K^{-1}) \Delta\nu(Hz)}$$

with W_v^s being the signal of interest.

The system noise temperature, T_{sys} , determines ΔT_{RMS} , i.e. defines the sensitivity of the receiver system.

When computing the noise power from the whole system, W_{sys} , we must take into account that each successive component sees the gain and noise from the previous one. We can write:

$$W_{sys} = W_A + W_{RX} = G_1 G_2 \dots G_N k T_{sys} \Delta v_{sys} = G_1 G_2 \dots G_N k T_A \Delta v_{sys} + G_1 G_2 \dots G_N k T_1 \Delta v_{sys} + G_2 \dots G_N k T_2 \Delta v_{sys} + \dots + G_N k T_N \Delta v_{sys}$$

where W_{sys} is the system noise power (W), W_A and W_{RX} are the noise power from antenna and the receiver, T_{sys} is the system noise temperature and T_i the generic equivalent noise temperature of each component i and Δv_{sys} is the system bandwidth resolution (defined by narrowest bandwidth component).

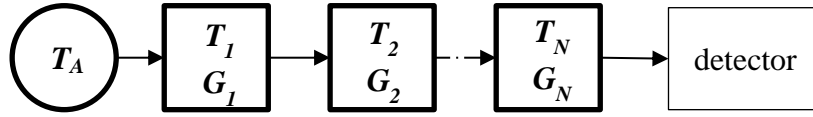

Fig. 6.5 Chain from antenna to detector.

From $T_{sys} = T_A + T_{RX}$ it follows:

$$T_{RX} = T_1 + \frac{T_2}{G_1} + \frac{T_3}{G_1 G_2} + \dots + \frac{T_N}{G_1 G_2 \dots G_{N-1}}$$

So to determine T_{sys} we must first determine the gain and equivalent black-body noise temperature of each component.

6.5 Mixer noise

In conditions of low pressure and relative humidity (high altitude conditions), the noise from the mixer dominates the noise performance of the instrument. Due to the fact that every mixer is inherently a DSB mixer, a SSB working mode can be reached by applying a filter for suppressing the unwanted sideband or by phasing the output of two DSB mixers.

The mixer down-converts the USB and LSB components of T_{in}^{mix} to the IF frequency with conversion gains, respectively, G_{USB} and G_{LSB} . During such a process, the mixer adds a noise signal, T_{DSB} to both sidebands.

Mathematically, this can be described as:

$$T_{IF} = \frac{T_{in}^{mix}}{G_{USB}} + \frac{T_{in}^{mix}}{G_{LSB}} + \frac{T_{DSB}}{G_{USB}} + \frac{T_{DSB}}{G_{LSB}}$$

with T_{IF} being the noise temperature (K) at mixer output IF port, T_{in}^{mix} the noise temperature (K) at mixer input (RF) port, G_{USB} and G_{LSB} the conversion gain for the upper and lower side bands.

Solving for T_{DSB} we have:

$$T_{DSB} = G_M T_{IF} - T_{in}^{mix}$$

being:

$$G_M = \frac{G_{USB} G_{LSB}}{G_{USB} + G_{LSB}}$$

For the SSB mode, we can make the assumption:

$$T_{SSB} \approx 2T_{DSB}$$

because the noise associated with the downconversion of both sidebands still contributes to the SSB noise temperature T_{SSB} . Also, the filter itself adds an unwanted noise in the signal sideband.

For a system composed of antenna + mixer + amplifier chain, we consider the chain starting after the mixer. In this case we have a contribution $T_{in}^{mix} = T_A$ and T_{DSB} extracted from the mixer datasheet, so, in the assumption of $G_{USB} \approx G_{LSB} = G$, we have a total system noise temperature:

$$T_{sys} = T_{IF} + T_{RX}$$

where

$$T_{IF} = \frac{T_A}{G_{USB}} + \frac{T_A}{G_{LSB}} + \frac{T_{DSB}}{G_{USB}} + \frac{T_{DSB}}{G_{LSB}} \approx \frac{1}{G_M} (T_A + T_{DSB}) = \frac{2}{G} (T_A + T_{DSB})$$

for the double side band case and

$$T_{IF} = \frac{1}{G} (T_A + T_{SSB})$$

for the single side band case.

6.6 Antenna

6.6.1 Directivity

The directive gain or directivity $D(\vartheta, \varphi)$ of a transmitting antenna in a given direction is the ratio of its radiation intensity $U(\vartheta, \varphi)$ in the direction of interest to its mean radiation intensity \bar{U} :

$$D(\vartheta, \varphi) = \frac{U(\vartheta, \varphi)}{\bar{U}}$$

being \bar{U} :

$$\bar{U} = \frac{P_0}{4\pi}$$

When the directivity D of an antenna is given independently of direction, it refers to its maximum directivity in any direction.

An isotropic antenna has unitary directivity in all directions. More generally the maximum, minimum, and mean directivities of any antenna are always at least 1, at most 1, and exactly 1.

6.6.2 Efficiency

A transmitting antenna accepts input power P_{in} at its input point (without considering the power lost due to joule heating and coupling) and emits a total radiated power to its environment:

$$P_{out} = \eta P_{in}$$

being η its efficiency.

6.6.3 Gain

The power gain (or simply gain $G(\vartheta, \varphi)$) of a transmitting antenna in a generic direction is defined as the ratio of its radiation intensity $U(\vartheta, \varphi)$ in such direction to the mean radiation intensity of a perfectly efficient isotropic antenna:

$$G(\vartheta, \varphi) = \frac{U(\vartheta, \varphi)}{P_{in}/4\pi}$$

The gain takes the efficiency η into account by using the efficiency definition:

$$G(\vartheta, \varphi) = \eta \frac{U(\vartheta, \varphi)}{P_{out}/4\pi} = \eta \frac{U(\vartheta, \varphi)}{\bar{U}}$$

and it follows:

$$G(\vartheta, \varphi) = \eta D(\vartheta, \varphi)$$

As with directivity, when the gain G of an antenna is given independently of direction it refers to its maximum gain in any direction. Since the only difference between gain and directivity in any direction is a constant factor η we obtain:

$$G_{max} = \eta D_{max}$$

Reciprocity justifies taking the properties of a receiving antenna, such as efficiency, directivity, and gain, to be those used for transmission. Thus, for a receiving antenna, the power in input (the received power) substitutes P_{out} in the formulas:

$$\eta_r = \frac{P_{in}}{P_{out}}$$

6.6.4 From antenna gain to transmitted signal efficiency

From the directivity $D = \frac{U(\vartheta, \varphi)}{\bar{U}}$, by integrating on the solid angle we obtain:

$$\int_{\Omega} D d\Omega = \frac{\int_{\Omega} U(\vartheta, \varphi) d\Omega}{\bar{U}}$$

and we can write an expression for the average directivity \bar{D} in a finite angular range as:

$$\bar{D} \Delta\Omega = \frac{\int_{\Omega} U(\vartheta, \varphi) d\Omega}{\bar{U}} = \frac{4\pi\bar{U}}{\bar{U}} = 4\pi$$

where $\Delta\Omega$ is:

$$\Delta\Omega = \int_0^{2\pi} \int_0^{\vartheta_0} d\Omega = 2\pi(1 - \cos \vartheta_0)$$

It follows:

$$\bar{D} = \frac{4\pi}{\Delta\Omega} = \frac{2}{1 - \cos \vartheta_0}$$

and the antenna efficiency (in transmission) η can be approximated, in the azimuthal angular range $0 - \vartheta_0$, as:

$$\eta = \frac{P_{out}}{P_{in}} = \frac{G}{\bar{D}}$$

Using the Half Power Beam Width (HPBW) value as azimuthal angular range, it follows:

$$\eta = \frac{G(1 - \cos \vartheta_0)}{2}$$

For a receiving antenna, the efficiency $\eta_r = \frac{P_{in}}{P_{out}}$ is given by the reciprocal value of η for the transmitting case.

6.7 Real instrument LO + Mixer

We analyse now different real system made up of the LO and the corresponding mixer. The mixer real efficiency has been calculated from the nominal efficiency by subtracting the difference in dBm between the nominal (expected) input power and the effectively input power.

6.7.1 Chain 0 - 2695 - 2705 GHz

The chain is made up by coupling the QCL with the custom mixer (properly dimensioned for managing the laser power) using a quasi-optics system. A proper mixer hosting a build-in antenna must be provided. Mixer

characteristics are taken from: Bulcha Et Al.: Design And Characterization Of 1.8–3.2 THz Schottky-Based Harmonic Mixers, IEEE Transactions On Terahertz Science And Technology, Vol. 6, No. 5, Sept. 2016.

We have estimated the nominal noise temperature by considering a square law dependence of the noise temperature on the frequency extrapolated from Virginia Diodes datasheets.

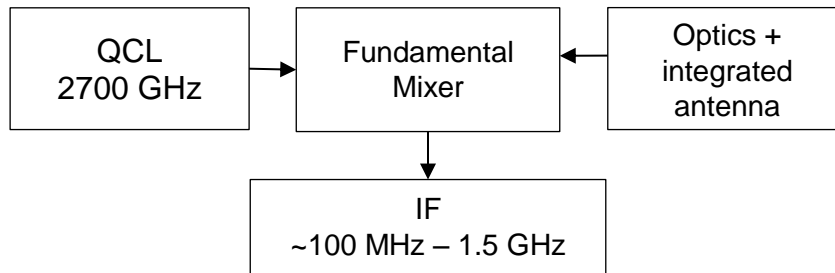
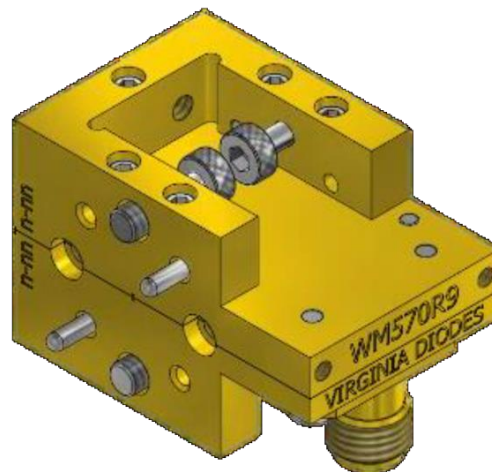

Fig. 6.6: Chain 0 (multiplier factor N = 1) scheme.

Chain N=1	Oscillator (QCL)
Model	Custom QCL laser @ 2.7 THz, FWHM 1 GHz
Central frequency (GHz)	2700 (single mode)
Working mode	CW
FWHM (GHz)	1.0
Average power	-
Power @ 10K	20 mW
Power @ 50K	5 mW
Working temperature (K)	10 to 70
Voltage (V)	4 to 5
Current (mA)	~ 100
Polarization	negative
Laser length (mm)	2.0
Laser size (mm)	0.15
Laser width (mm)	0.01
Beam divergence (deg)	30 – 35 (on both axis)
Beam FWHM (μm)	150

Chain N=1	Mixer
Model	Custom WR0.34
Producer	Suggested: VDI Virginia Diodes
Nominal efficiency/gain	0.0010 – 0.0003
Nominal efficiency (dB)	-30 ÷ -35
Real mixer efficiency (dB)	-30 ÷ -35
Max input power (mW)	5.0 mW
Max input power (dbm)	7.0
Output Power (mW)	0.005 – 0.001
Nominal noise temper. (K)	20000 – 40000 K
Min frequency in (GHz)	1800 GHz
Max frequency in (GHz)	3300 GHz
Min frequency out (GHz)	1800 GHz
Max frequency out (GHz)	3300 GHz
Min frequency band (GHz)	500.00 GHz
Max frequency band (GHz)	660.00 GHz
Input port	WR-0.34
Output port	2.4mm(f)
RF input port	WR-1.5 (UG-387/UM)
Note	Effective band: 2200 - 3300 GHz



Courtesy of Virginia Diodes, Inc.
www.vadiodes.com

Chain N=1	Antenna (Integrated with the mixer block)
Model	Custom model
Producer	-
Nominal efficiency/gain	0.85
Nominal efficiency (dB)	0.7
Real mixer efficiency (dB)	
Max input power (mW)	
Max input power (dbm)	
Output Power (mW)	
Output Power (dBm)	
Min frequency in (GHz)	2200.00 GHz
Max frequency in (GHz)	3300.00 GHz
Min frequency out (GHz)	2200.00 GHz
Max frequency out (GHz)	3300.00 GHz
Min frequency band (GHz)	
Max frequency band (GHz)	
Input port	WR0.34 (WM-86)
Output port	
RF input port	
Note	Horn length: 3 mm, aperture diameter: 0.56 mm, FOV: 10°.

6.7.2 Chain 1 - 500 – 660 GHz

This chain reaches lower frequencies and is intended to represent both an alternative to the use of a laser source and a proof-of-concept for practising this type of devices for starting setting up a benchmark for laboratory measurements. Power input in the subharmonic (x 2) mixer is 1.9 mW @ 225 – 330 GHz. The effective tuning band is 500 – 660 GHz.

Chain N=6	Oscillator
Model	Full Band Mech. Tuned Gunn Osc. OGF-1003-01 75-110_GHz
Producer	Ducommun
Nominal efficiency/gain	
Nominal efficiency (dB)	
Real mixer efficiency (dB)	
Max input power (mW)	
Max input power (dbm)	
Output Power (mW)	2.0 mW
Output Power (dBm)	3 dBm
Min frequency in (GHz)	
Max frequency in (GHz)	
Min frequency out (GHz)	75.00 GHz
Max frequency out (GHz)	110.00 GHz
Min frequency band (GHz)	75.00 GHz
Max frequency band (GHz)	110.00 GHz
Input port	
Output port	WR-10
RF input port	
Note	mechanically tuned (micrometric)

Chain N=6	Amplifier
Model	WPA-10-882015
Producer	Wasa Millimeter Wave
Nominal efficiency/gain	31.6227766
Nominal efficiency (dB)	
Real mixer efficiency (dB)	
Max input power (mW)	31.6227766
Max input power (dbm)	
Output Power (mW)	63.1 mW
Output Power (dBm)	18 dBm
Min frequency in (GHz)	75.00 GHz
Max frequency in (GHz)	110.00 GHz
Min frequency out (GHz)	75.00 GHz
Max frequency out (GHz)	110.00 GHz
Min frequency band (GHz)	75.00 GHz
Max frequency band (GHz)	110.00 GHz
Input port	WR-10
Output port	WR-10
RF input port	
Note	



Courtesy of Wasa Millimeter Wave
www.wmmw.se

Chain N=6	Multiplier x3
Model	WR3.4x3 (Model HP)
Producer	VDI Virginia Diodes
Nominal efficiency/gain	0.03
Nominal efficiency (dB)	
Real mixer efficiency (dB)	
Max input power (mW)	S (5-40 mW) HP (20-120 mW) UHP (50-150 mW)
Max input power (dbm)	
Output Power (mW)	1.89 mW
Output Power (dBm)	2.8 dBm
Min frequency in (GHz)	73.33 GHz
Max frequency in (GHz)	110.00 GHz
Min frequency out (GHz)	220.00 GHz
Max frequency out (GHz)	330.00 GHz
Min frequency band (GHz)	225.00 GHz
Max frequency band (GHz)	330.00 GHz
Input port	WR-10.2(UG-387/UM)
Output port	WR-3.4 (UG-387/UM)
RF input port	
Note	

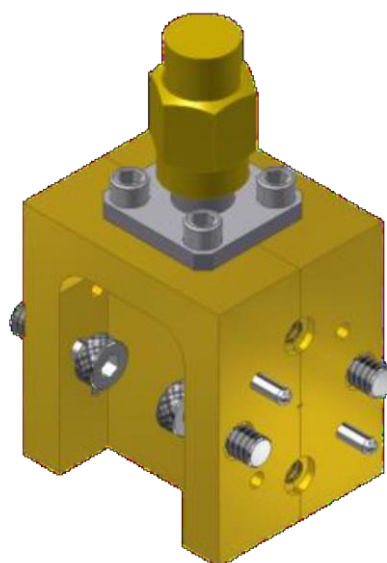

Courtesy of Virginia Diodes, Inc.
www.vadiodes.com

Chain N=6	Mixer x 2
Model	WR1.5SHM
Producer	VDI Virginia Diodes
Nominal efficiency/gain	0.079432823
Nominal efficiency (dB)	-11.00
Real mixer efficiency (dB)	-13.73
Max input power (mW)	2.51 - 5.01 mW
Max input power (dbm)	5.5
Output power (mW)	-
Nominal noise temper. (K)	2000 – 5000 K
Min frequency in (GHz)	250.00 GHz
Max frequency in (GHz)	375.00 GHz
Min frequency out (GHz)	500.00 GHz
Max frequency out (GHz)	750.00 GHz
Min frequency band (GHz)	500.00 GHz
Max frequency band (GHz)	660.00 GHz
Input port	WR-3.0(UG-387/UM)
Output port	2.4mm(f)
RF input port	WR-1.5 (UG-387/UM)
Note	Effective band: 500 - 660 GHz

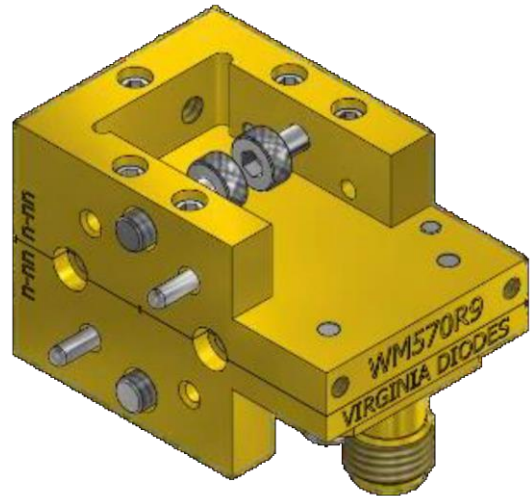

Courtesy of Virginia Diodes, Inc.
www.vadiodes.com

Chain N=6	Antenna
Model	FH-PP-750
Producer	Radiometer Physics
Nominal efficiency/gain	0.41
Nominal efficiency (dB)	
Real mixer efficiency (dB)	
Max input power (mW)	
Max input power (dbm)	
Output Power (mW)	
Output Power (dBm)	
Min frequency in (GHz)	500.00 GHz
Max frequency in (GHz)	750.00 GHz
Min frequency out (GHz)	500.00 GHz
Max frequency out (GHz)	750.00 GHz
Min frequency band (GHz)	
Max frequency band (GHz)	
Input port	WR1.5 (UG387/UM)
Output port	
RF input port	
Note	

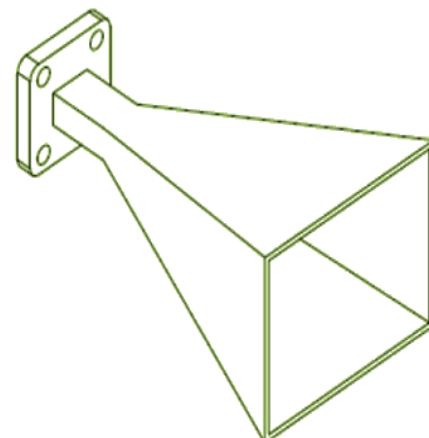

Generic horn antenna

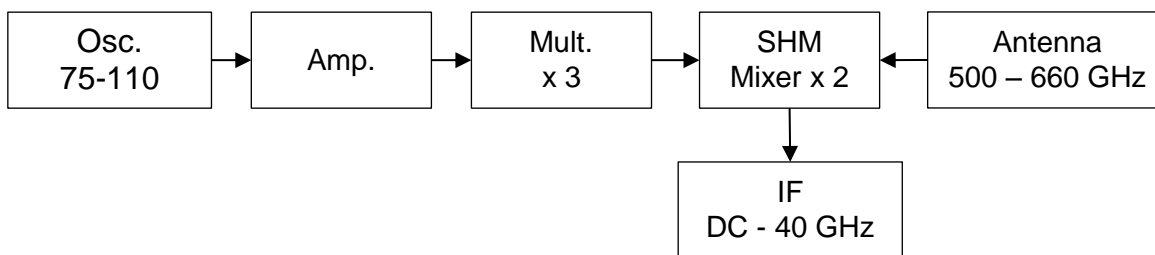



Fig. 6.7: Chain 1 (multiplier factor N = 6) scheme.

6.7.3 Chain 2 - 660 - 740 GHz

This chain reaches higher frequencies with respect to chain 1 using on-the-shelf components. Frequency tuning is performed by micrometric control of a Gunn diode and LO power input is controlled by micrometric tuning of the attenuator. Power input in the subharmonic (x 2) mixer is 1.4 mW @ 330 - 370 GHz. The effective tuning band is 660 - 740 GHz.

Chain N=20	Oscillator
Model	OGF-2820-01
Producer	Ducommun
Nominal efficiency/gain	
Nominal efficiency (dB)	
Real mixer efficiency (dB)	
Max input power (mW)	
Max input power (dbm)	
Output Power (mW)	100.0 mW
Output Power (dBm)	20 dBm
Min frequency in (GHz)	
Max frequency in (GHz)	
Min frequency out (GHz)	26.50 GHz
Max frequency out (GHz)	40.00 GHz
Min frequency band (GHz)	26.50 GHz
Max frequency band (GHz)	36.67 GHz
Input port	
Output port	WR-28 W/UG599/U
RF input port	
Note	Custom power and frequency on request

Chain N=20	Attenuator
Model	STA-30-28-M2
Producer	Sage Millimeters
Nominal efficiency/gain	0 to -30 dB (set to -1.5 dB)
Nominal efficiency (dB)	
Real mixer efficiency (dB)	
Max input power (mW)	1200 mW
Max input power (dbm)	
Output Power (mW)	70.0 mW
Output Power (dBm)	18.45
Min frequency in (GHz)	26.50 GHz
Max frequency in (GHz)	40.00 GHz
Min frequency out (GHz)	26.50 GHz
Max frequency out (GHz)	40.00 GHz
Min frequency band (GHz)	26.50 GHz
Max frequency band (GHz)	36.67 GHz
Input port	WR-28 (UG-599/U)
Output port	WR-28 (UG-599/U)
RF input port	
Note	Tuneable 0 - 35 dB attenuation



Courtesy of SAGE Millimeters, www.sagemillimeter.com
www.sagemillimeter.com/26-5-to-40-ghz-0-to-35-db-wr-28-waveguide-ka-band-level-setting-attenuator

Chain N=20	Amplifier
Model	QPW-30403010
Producer	Quinstar
Nominal efficiency/gain	10
Nominal efficiency (dB)	
Real mixer efficiency (dB)	
Max input power (mW)	100 mW
Max input power (dbm)	
Output Power (mW)	700.0 mW
Output Power (dBm)	28.45
Min frequency in (GHz)	30.00 GHz
Max frequency in (GHz)	40.00 GHz
Min frequency out (GHz)	30.00 GHz
Max frequency out (GHz)	40.00 GHz
Min frequency band (GHz)	26.50 GHz
Max frequency band (GHz)	36.67 GHz
Input port	WR-28 (custom)
Output port	WR-28 (custom)
RF input port	
Note	

Chain N=20	Multiplier (I) x 5
Model	WX5-1400#05
Producer	Wasa Millimeter Wave
Nominal efficiency/gain	0.049
Nominal efficiency (dB)	
Real mixer efficiency (dB)	
Max input power (mW)	800 mW
Max input power (dbm)	
Output Power (mW)	34.1 mW
Output Power (dBm)	15.33
Min frequency in (GHz)	33.00 GHz
Max frequency in (GHz)	37.00 GHz
Min frequency out (GHz)	165.00 GHz
Max frequency out (GHz)	185.00 GHz
Min frequency band (GHz)	132.50 GHz
Max frequency band (GHz)	183.33 GHz
Input port	WR-28 , UG-599/U
Output port	WR-5/WM-1295 , UG-387/U
RF input port	
Note	

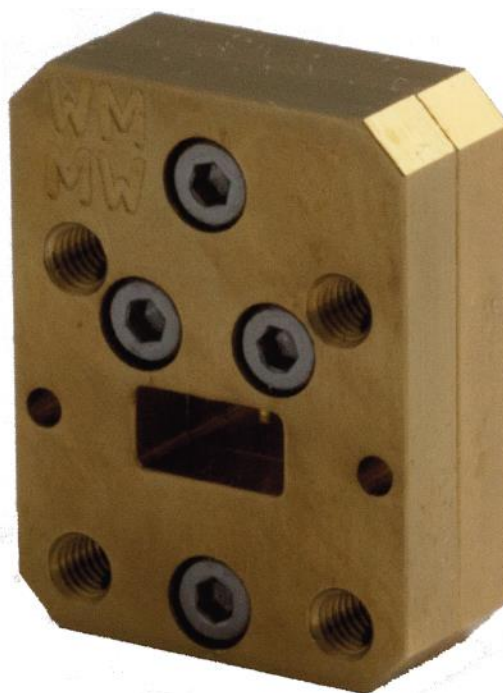

Courtesy of Wasa Millimeter Wave
www.wmmw.se

Chain N=20	Multiplier (II) x 2
Model	WR2.8x2
Producer	VDI Virginia Diodes
Nominal efficiency/gain	0.04
Nominal efficiency (dB)	
Real mixer efficiency (dB)	
Max input power (mW)	10 - 35 mW
Max input power (dbm)	
Output Power (mW)	1.4 mW
Output Power (dBm)	1.35
Min frequency in (GHz)	130.00 GHz
Max frequency in (GHz)	200.00 GHz
Min frequency out (GHz)	260.00 GHz
Max frequency out (GHz)	400.00 GHz
Min frequency band (GHz)	330.00 GHz
Max frequency band (GHz)	370.00 GHz
Input port	WR-5.1 (UG-387/UM)
Output port	WR-2.8 (UG-387/UM)
RF input port	
Note	

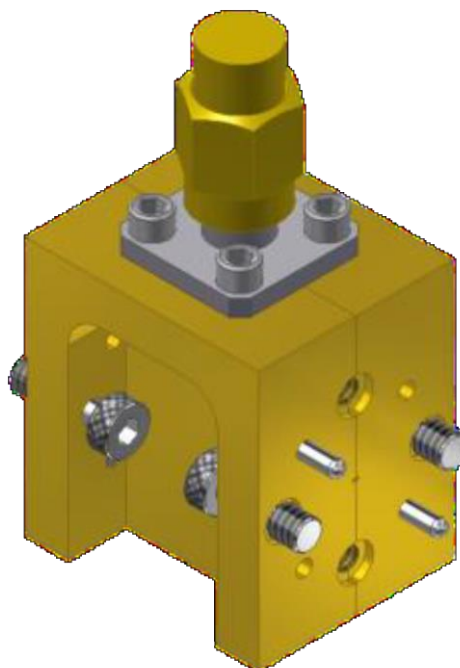

Courtesy of Virginia Diodes, Inc.
www.vadiodes.com

Chain N=20	Mixer x 2
Model	WR1.5SHM
Producer	VDI Virginia Diodes
Nominal efficiency/gain	0.079432823
Nominal efficiency (dB)	-11
Real mixer efficiency (dB)	-15.15
Max input power (mW)	2.51 - 5.01 mW
Max input power (dbm)	5.5
Output power (mW)	-
Nominal noise temper. (K)	2000 – 5000 K
Min frequency in (GHz)	250.00 GHz
Max frequency in (GHz)	375.00 GHz
Min frequency out (GHz)	500.00 GHz
Max frequency out (GHz)	750.00 GHz
Min frequency band (GHz)	660.00 GHz
Max frequency band (GHz)	740.00 GHz
Input port	WR-3.0 (UG-387/UM)
Output port	2.4mm(f)
RF input port	WR-1.5 (UG-387/UM)
Note	Effective band: 660 - 740 GHz

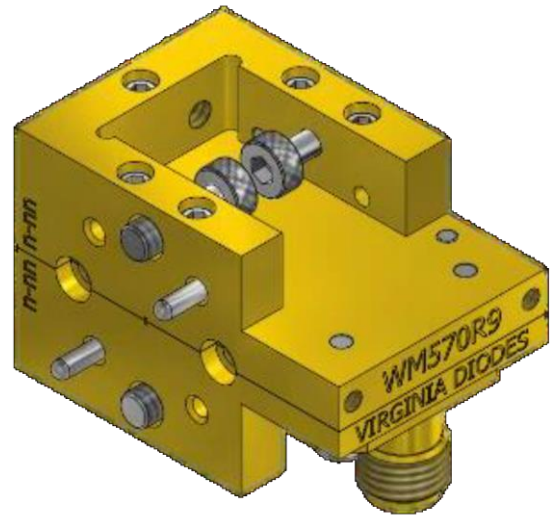

Courtesy of Virginia Diodes, Inc.
www.vadiodes.com

Chain N=20	Antenna
Model	FH-PP-750
Producer	Radiometer Physics
Nominal efficiency/gain	0.41
Nominal efficiency (dB)	
Real mixer efficiency (dB)	
Max input power (mW)	
Max input power (dbm)	
Output Power (mW)	
Output Power (dBm)	
Min frequency in (GHz)	500.00 GHz
Max frequency in (GHz)	750.00 GHz
Min frequency out (GHz)	500.00 GHz
Max frequency out (GHz)	750.00 GHz
Min frequency band (GHz)	
Max frequency band (GHz)	
Input port	WR1.5 (UG387/UM)
Output port	
RF input port	
Note	

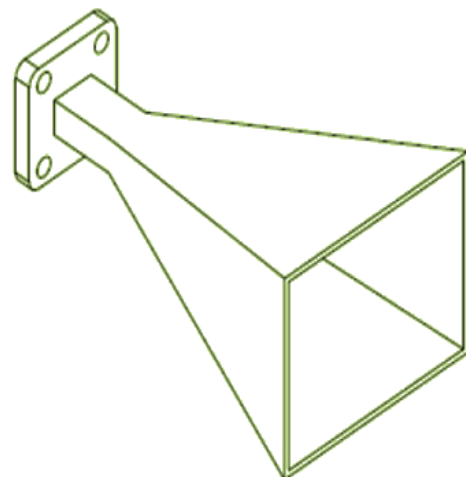

Generic horn antenna

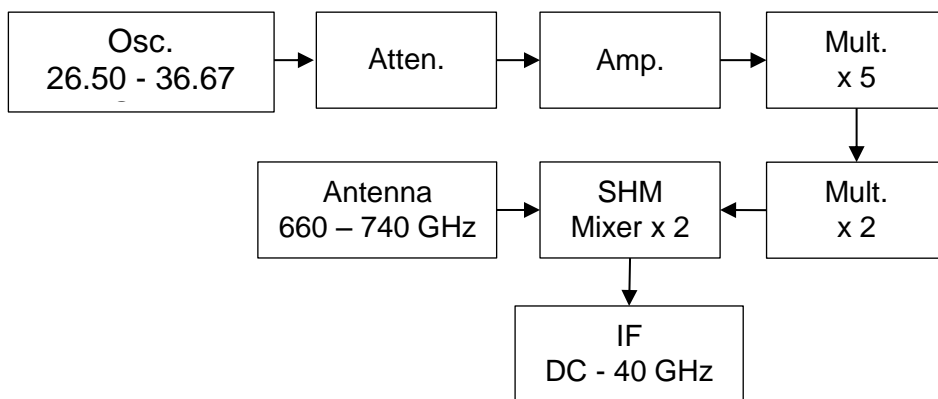



Fig. 6.8: Chain 2 (multiplier factor N = 20) scheme.

6.7.4 Chain 3 - 795 - 1100 GHz

This chain reaches THz frequencies using on-the-shelf components. As in chain 2, both frequency and radiometric tuning are performed by micrometric control. Power input in the subharmonic (x 2) mixer is 0.5 mW @ 397.5 – 550.0 GHz. The effective tuning band is 795 – 1100 GHz.

Chain N=30	Oscillator
Model	OGF-2820-01
Producer	Ducommun
Nominal efficiency/gain	
Nominal efficiency (dB)	
Real mixer efficiency (dB)	
Max input power (mW)	
Max input power (dbm)	
Output Power (mW)	100.0 mW
Output Power (dBm)	20 dBm
Min frequency in (GHz)	
Max frequency in (GHz)	
Min frequency out (GHz)	26.50 GHz
Max frequency out (GHz)	40.00 GHz
Min frequency band (GHz)	26.50 GHz
Max frequency band (GHz)	36.67 GHz
Input port	
Output port	WR-28 W/UG599/U
RF input port	
Note	Power and frequency can be customized

Chain N=30	Attenuator
Model	STA-30-28-M2
Producer	Sage Millimeters
Nominal efficiency/gain	0 to -30 dB (set to -1.5 dB)
Nominal efficiency (dB)	
Real mixer efficiency (dB)	
Max input power (mW)	1200 mW
Max input power (dbm)	
Output Power (mW)	70.0 mW
Output Power (dBm)	18.45
Min frequency in (GHz)	26.50 GHz
Max frequency in (GHz)	40.00 GHz
Min frequency out (GHz)	26.50 GHz
Max frequency out (GHz)	40.00 GHz
Min frequency band (GHz)	26.50 GHz
Max frequency band (GHz)	36.67 GHz
Input port	WR-28 (UG-599/U)
Output port	WR-28 (UG-599/U)
RF input port	
Note	Tunable 0 - 35 dB attenuation



Courtesy of SAGE Millimeters, www.sagemillimeter.com
www.sagemillimeter.com/26-5-to-40-ghz-0-to-35-db-wr-28-waveguide-ka-band-level-setting-attenuator

Chain N=30	Amplifier
Model	QPW-30403010
Producer	Quinstar
Nominal efficiency/gain	10
Nominal efficiency (dB)	
Real mixer efficiency (dB)	
Max input power (mW)	100 mW
Max input power (dbm)	
Output Power (mW)	700.0 mW
Output Power (dBm)	28.45
Min frequency in (GHz)	30.00 GHz
Max frequency in (GHz)	40.00 GHz
Min frequency out (GHz)	30.00 GHz
Max frequency out (GHz)	40.00 GHz
Min frequency band (GHz)	26.50 GHz
Max frequency band (GHz)	36.67 GHz
Input port	WR-28 (to be requested to the producer)
Output port	WR-28 (custom)
RF input port	
Note	

Chain N=30	Multiplier (I) x 5
Model	WX5-1400#05
Producer	Wasa Millimeter Wave
Nominal efficiency/gain	0.049
Nominal efficiency (dB)	
Real mixer efficiency (dB)	
Max input power (mW)	800 mW
Max input power (dbm)	
Output Power (mW)	34.1 mW
Output Power (dBm)	15.33
Min frequency in (GHz)	33.00 GHz
Max frequency in (GHz)	37.00 GHz
Min frequency out (GHz)	165.00 GHz
Max frequency out (GHz)	185.00 GHz
Min frequency band (GHz)	132.50 GHz
Max frequency band (GHz)	183.33 GHz
Input port	WR-28 , UG-599/U
Output port	WR-5/WM-1295 , UG-387/U
RF input port	
Note	

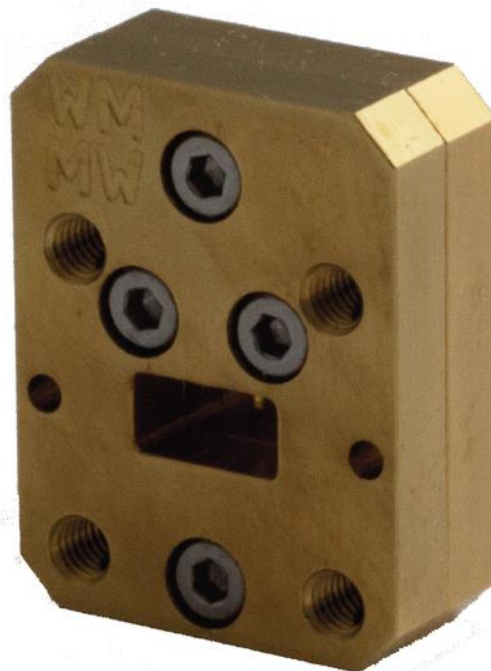

Courtesy of Wasa Millimeter Wave
www.wmmw.se

Chain N=30	Multiplier (II) x 3
Model	WR1.9x3 (HP model)
Producer	VDI Virginia Diodes
Nominal efficiency/gain	0.015
Nominal efficiency (dB)	
Real mixer efficiency (dB)	
Max input power (mW)	S (10 - 25 mW) HP (15 - 100 mW) UHP (30 - 150 mW)
Max input power (dbm)	
Output Power (mW)	0.5 mW
Output Power (dBm)	-2.91
Min frequency in (GHz)	133.33 GHz
Max frequency in (GHz)	200.00 GHz
Min frequency out (GHz)	400.00 GHz
Max frequency out (GHz)	600.00 GHz
Min frequency band (GHz)	397.50 GHz
Max frequency band (GHz)	550.00 GHz
Input port	WR-5.7 (UG-387/UM)
Output port	WR-1.9 (UG-387/UM)
RF input port	
Note	

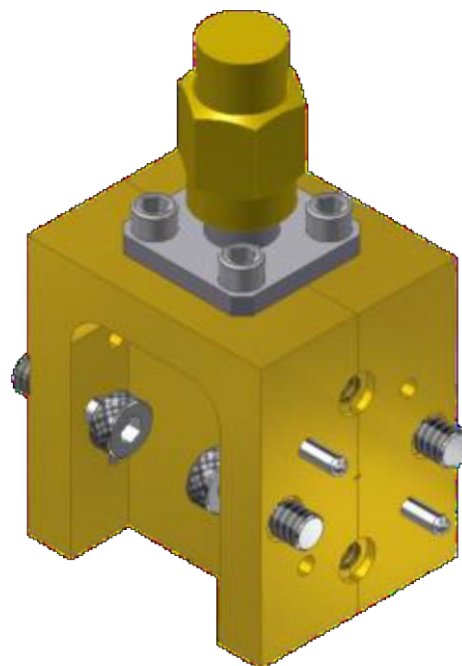

Courtesy of Virginia Diodes, Inc.
www.vadiodes.com

Chain N=30	Mixer x 2
Model	WR1.0SHM
Producer	VDI Virginia Diodes
Nominal efficiency/gain	0.01
Nominal efficiency (dB)	-20
Real mixer efficiency (dB)	-28.41
Max input power (mW)	2.51 - 5.01 mW
Max input power (dbm)	5.5
Output power (mW)	-
Nominal noise temper. (K)	7500 – 15000 K
Min frequency in (GHz)	375.00 GHz
Max frequency in (GHz)	550.00 GHz
Min frequency out (GHz)	750.00 GHz
Max frequency out (GHz)	1100.00 GHz
Min frequency band (GHz)	795.00 GHz
Max frequency band (GHz)	1100.00 GHz
Input port	WR-2.0(UG-387/UM)
Output port	2.4mm(f)
RF input port	WR-1 (UG-387/UM)
Note	Effective band: 795 - 1100 GHz

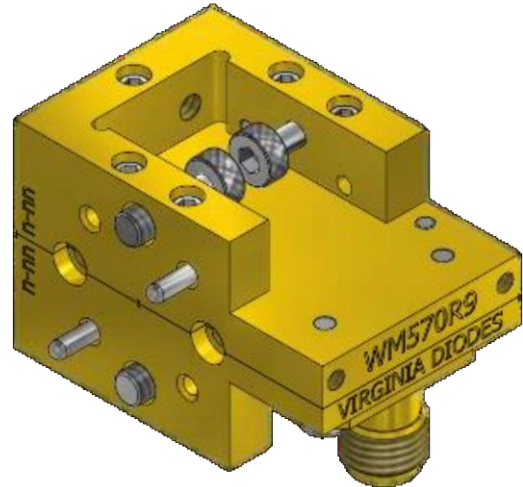

Courtesy of Virginia Diodes, Inc.
www.vadiodes.com

Chain N=30	Antenna
Model	FH-PP-1100
Producer	Radiometer Physics
Nominal efficiency/gain	0.41
Nominal efficiency (dB)	
Real mixer efficiency (dB)	
Max input power (mW)	
Max input power (dbm)	
Output Power (mW)	
Output Power (dBm)	
Min frequency in (GHz)	750.00 GHz
Max frequency in (GHz)	1100.00 GHz
Min frequency out (GHz)	750.00 GHz
Max frequency out (GHz)	1100.00 GHz
Min frequency band (GHz)	
Max frequency band (GHz)	
Input port	WR1 (UG387/UM)
Output port	
RF input port	
Note	

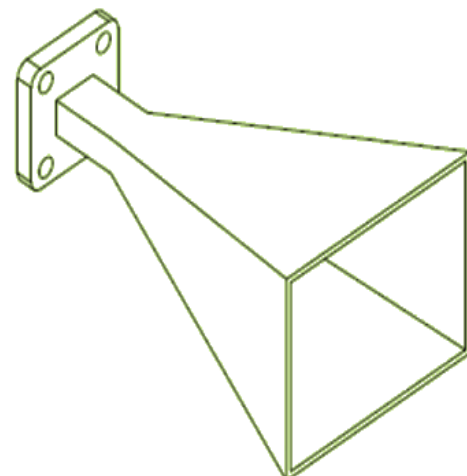

Generic horn antenna

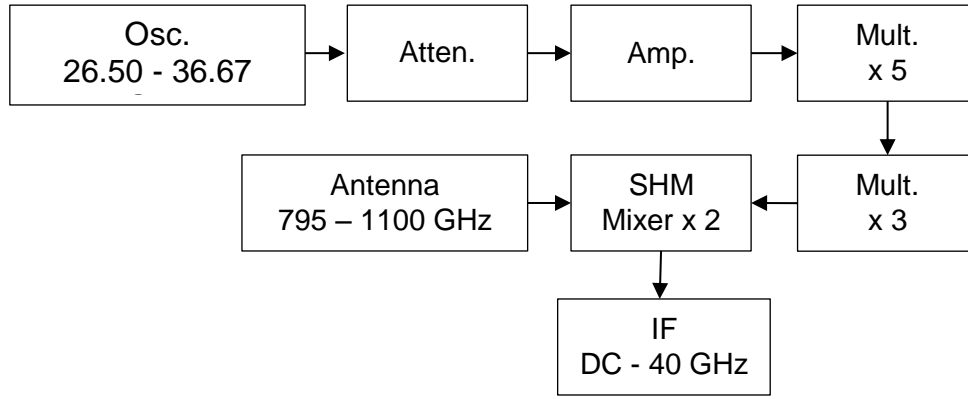

Fig. 6.9: Chain 3 (multiplier factor N = 30) scheme.

6.8 Calculation of SNR for the generic chain

We make the assumption that:

$$T_{sys} \approx T_{MIX}$$

with T_{MIX} being the mixer's equivalent noise temperature from datasheet associated to the signal at the exit of the mixer T_{IF} (see also par. 6.5).

The RMS noise temperature can be expressed as:

$$\Delta T_{RMS} = \frac{K_s T_{sys}}{\sqrt{\Delta \tau_{int} \Delta \nu}}$$

We define the equivalent temperature T_v^s (calculated from the radiance $L_\nu (W m^{-2} sr^{-1} Hz^{-1})$ from HITRAN simulations by inverting the Planck law for a blackbody) as:

$$T_v^s = \frac{h\nu}{k} \left[\ln \left(1 + \frac{2h\nu^3}{L_\nu c^2} \right) \right]^{-1}$$

and the SNR can be calculated as:

$$SNR = \frac{\eta T_v^s}{\Delta T_{RMS}} \approx \eta T_v^s \frac{\sqrt{\Delta \tau_{int} \Delta \nu}}{K_s T_{MIX}}$$

where η is the attenuation given by the mixer, T_v^s is the signal before the mixer and we consider $T_{sys} \approx T_{MIX}$.

The formula has been inverted for $\Delta \tau_{int}$ in different cases:

$$\Delta \tau_{int} \approx \frac{(K_s T_{MIX} SNR)^2}{\Delta \nu \eta^2 T_v^s{}^2}$$

Given the atmospheric brightness temperature, calculated both for a polluted and for an unpolluted standard atmosphere at different altitudes and for different path lengths (see Fig. 6.10), the difference in brightness temperature between the two atmosphere has been determined in all the cases (Fig. 6.11).

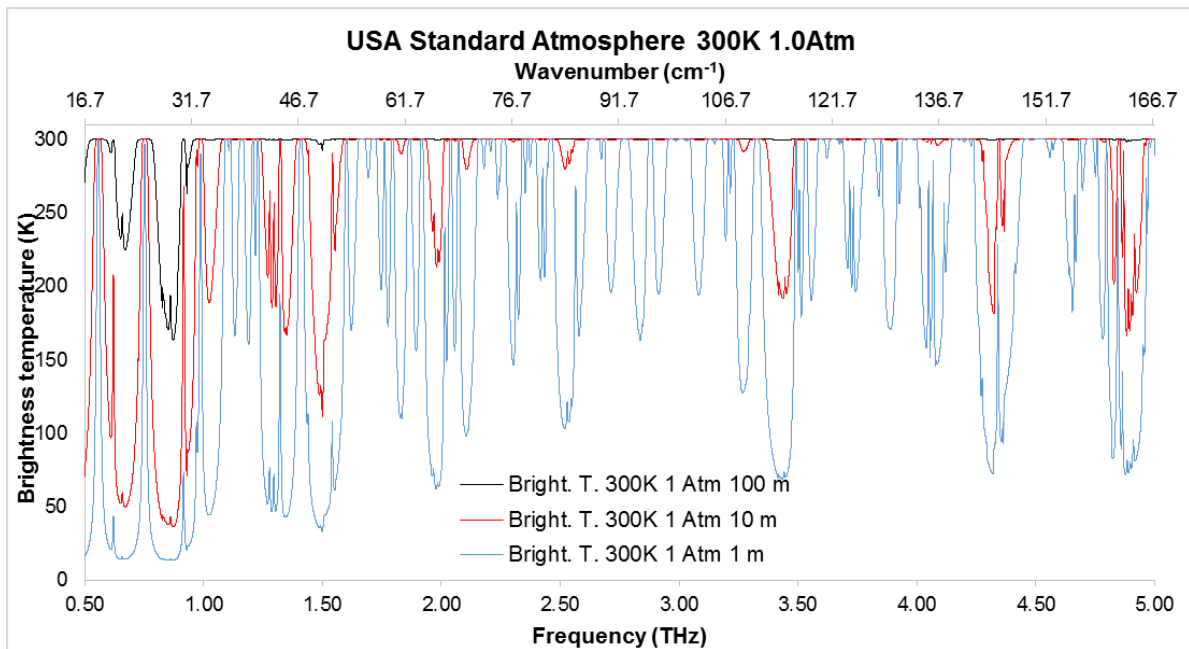

(a)

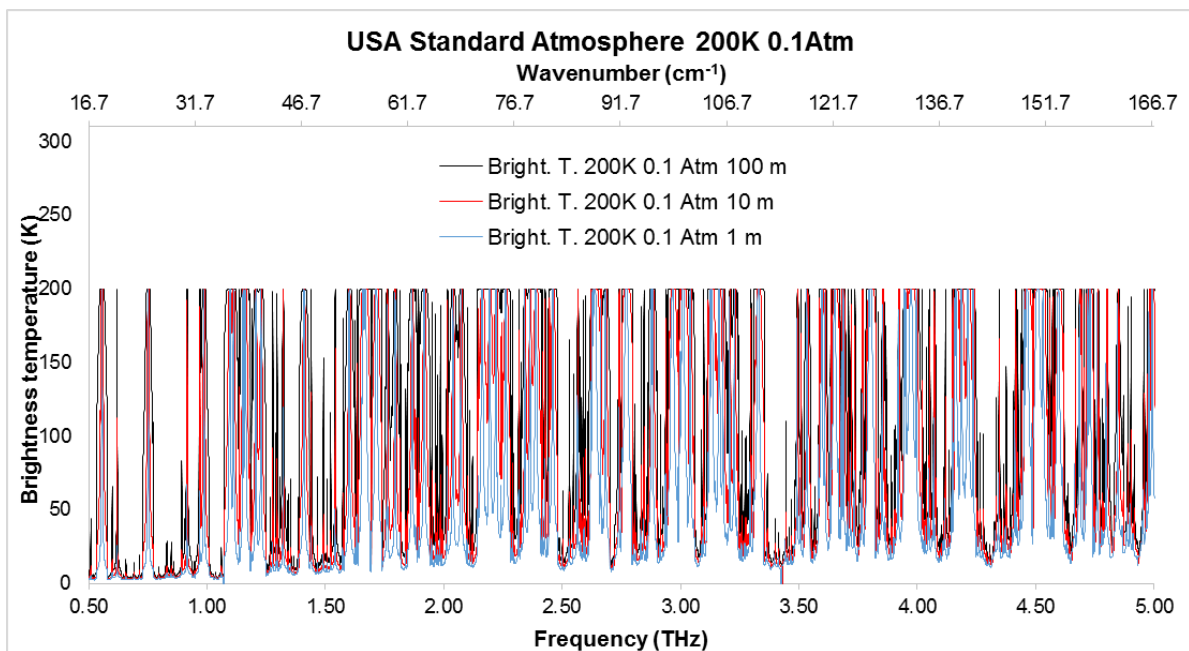

(b)

Fig. 6.10: Brightness temperature for a path of, respectively, 1m, 10m, 100m in a homogeneous medium for: (a) a standard atmosphere at 300K and 1.0 Atm pressure (corresponding to sea level conditions); (b) a standard atmosphere at 200K and 0.1 Atm pressure (corresponding to high tropospheric conditions).

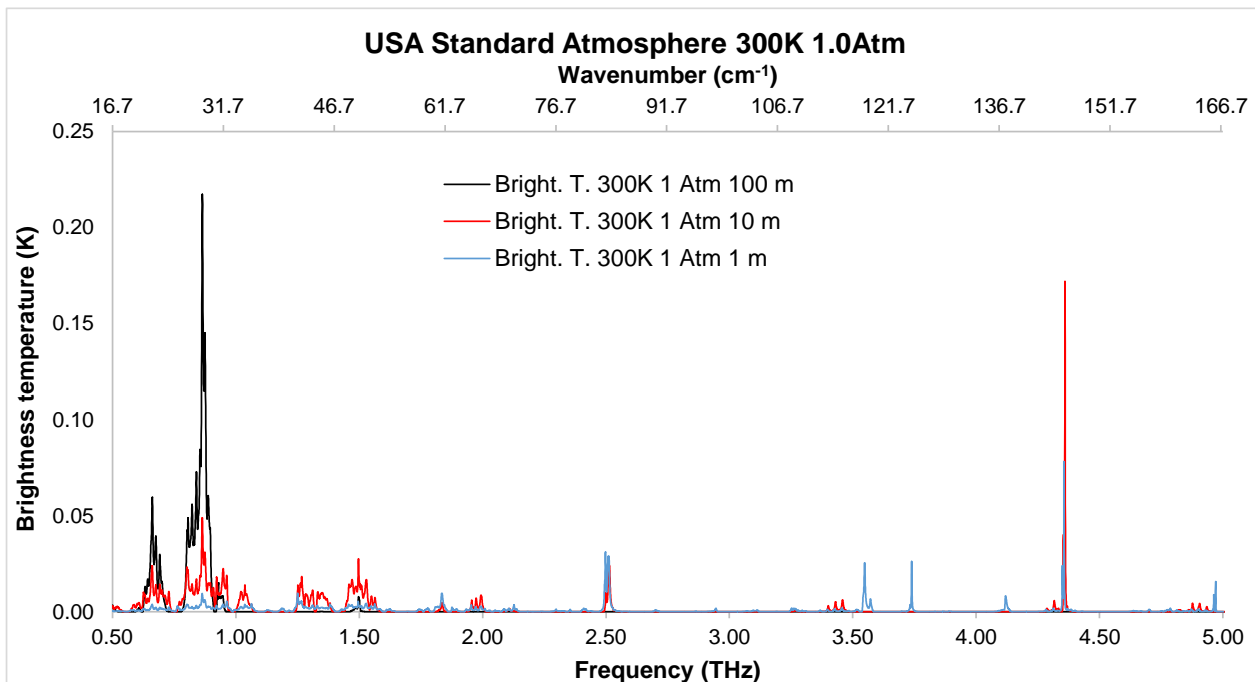

(a)

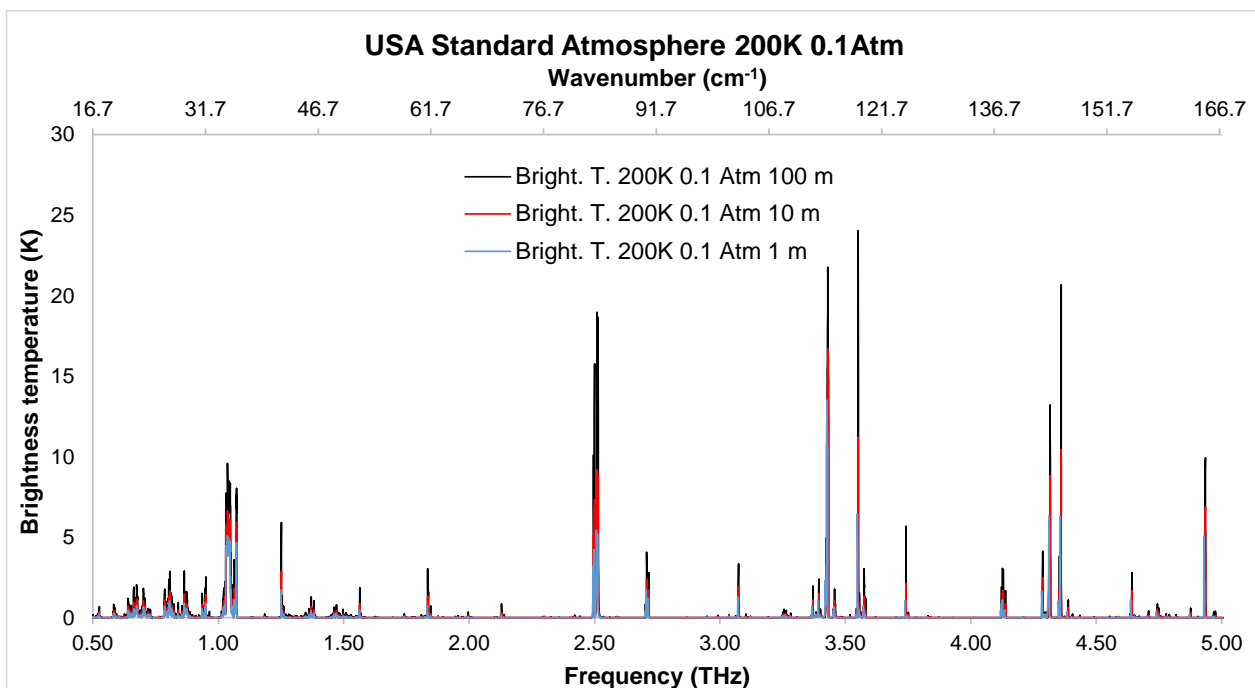

(b)

Fig. 6.11: Brightness temperature difference between polluted and unpolluted standard atmosphere for a path of, respectively, 1m, 10m, 100m in a homogeneous medium for: (a) 300K and 1.0 Atm pressure (corresponding to sea level conditions); (b) 200K and 0.1 Atm pressure (corresponding to high tropospheric conditions).

The composition of the polluted and unpolluted atmospheres are reported in the following table.

Atmospheric component (fraction)	Polluted atmosphere	Unpolluted atmosphere
Water vapour (H ₂ O)	0.01860000	0.01860000
Carbon dioxide (CO ₂)	0.00033000	0.00033000
Ozone (O ₃)	0.00000003	0.00000003
Nitrous oxide (N ₂ O)	0.00000028	0.00000016
Carbon monoxide (CO)	0.00000047	0.00000015
Methane (CH ₄)	0.00000170	0.00000170
Dioxygen (O ₂)	0.20900000	0.20900000
Sulfur dioxide (SO ₂)	0.00000008	0.00000000
Ammonia (NH ₃)	0.00000001	0.00000000
Hydroxyl radical (OH)	0.00000001	0.00000000
Hydrogen chloride (HCl)	0.00000001	0.00000000
Formaldehyde (H ₂ CO)	0.00000001	0.00000000
Hypochlorous acid (HOCl)	0.00000001	0.00000000
Nitrogen (N ₂)	0.77206738	0.77206738
Hydrogen sulfide (H ₂ S)	0.00000001	0.00000000

By considering:

- $T_{sys} \approx T_{MIX}$;
- $SNR = 1$ (worst case scenario in which $\Delta T_{RMS} = T_v^s$, and using for T_v^s the brightness temperature difference between polluted and unpolluted atmosphere);
- T_{MIX} = maximum mixer noise temperature (from datasheet, for fundamental mixer of chain 0 a realistic hypothetical value of 40000 K has been used);
- $K_s = 1$;

for each chain it is possible to calculate the minimum value for the product $\Delta\tau_{int}\Delta\nu$.

The values of the corresponding maximum sampling rate value (i.e. the number of samplings per seconds, corresponding to $1/\Delta\tau_{int}$ [s⁻¹]) with $SNR = 1$ and $\Delta\nu = 1$ GHz have been calculated for each chain as shown in the following subsections.

The value of the maximum sampling rate value (i.e. the number of samplings per seconds) for having SNR at least 1 with $\Delta\nu = 1$ GHz has been calculated for the all the chains.

Chain 0 (detailed in par. 6.7.1) uses of a QCL as local oscillator.

Chains 1 and 2 (par. 6.7.2 and 6.7.3) make use of commercial (on the shelf) components and operate in a lower frequency range (< 1 THz). Chain 3 (par. 6.7.4) reaches 1100 GHz still making use of commercial components.

The peaks correspond to signal maxima (i.e. the signal can be sampled a higher number of times for second for maintaining $SNR = 1$, i.e. the minimum signal (the temperature difference between the polluted and unpolluted atmosphere) is equal to the noise temperature (i.e. the noise given by the mixer, being the major temperature noise source).

6.8.1 Chain 0

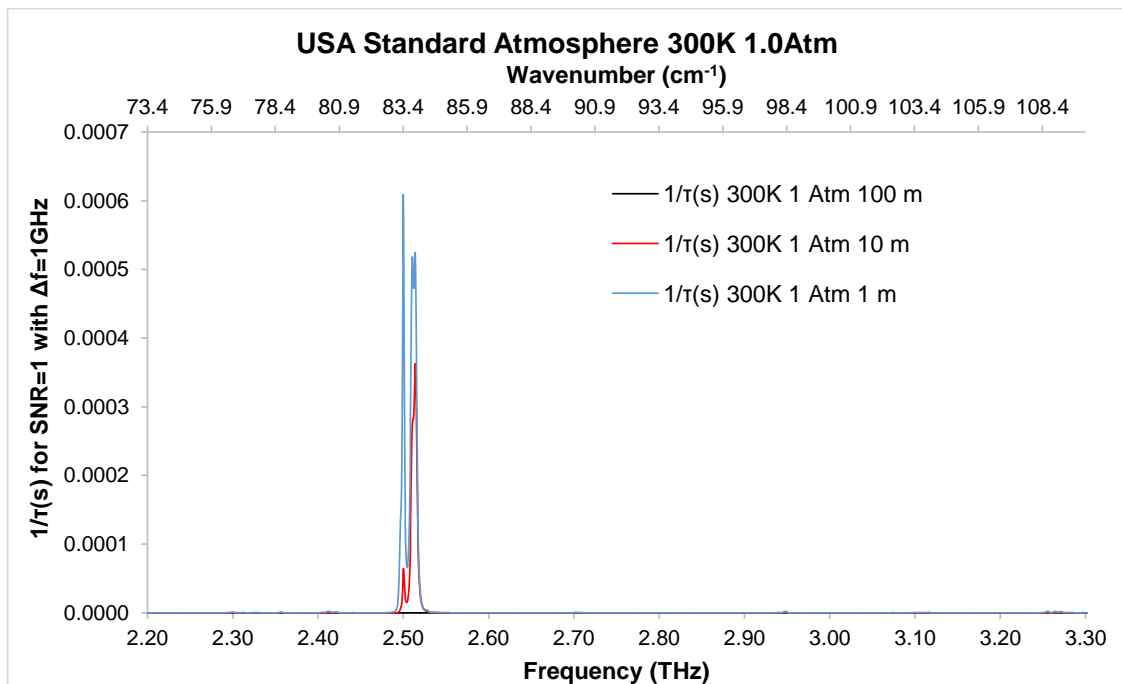

Fig. 6.12: Maximum sampling rate for chain 0 for having $SNR = 1$ and $\Delta\nu = 1\text{GHz}$ for a path of, respectively, 1m , 10m , 100m in a homogeneous medium. Higher is the value, shorter is the corresponding integration time $\Delta\tau_{int}$. The sampling rate scales with the SNR square value and is inversely proportional to $\Delta\nu$. The chart has been generated using a standard atmosphere at 300K and 1.0Atm pressure (corresponding to sea level conditions).

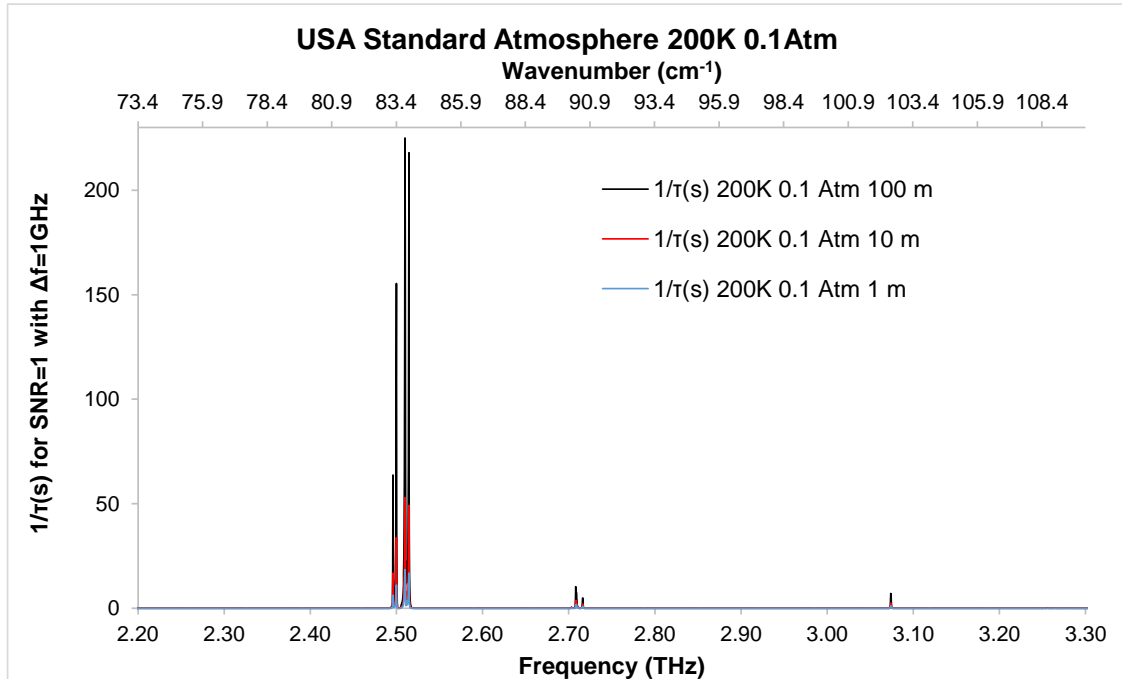

Fig. 6.13: Maximum sampling rate for chain 0 for a path of, respectively, 1m , 10m , 100m in a homogeneous medium. The chart has been generated using a standard atmosphere at 200K and 0.1Atm pressure (corresponding to high tropospheric conditions).

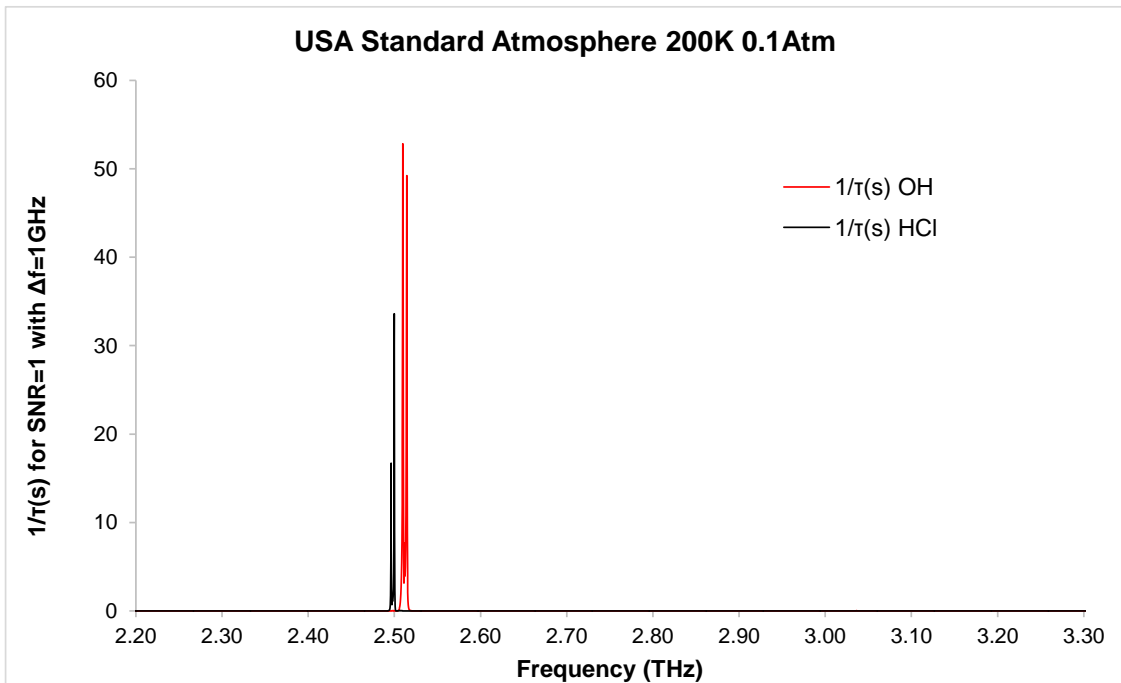

Fig. 6.14: Maximum sampling rate for the species observed by Chain 0 instrument for a 10 m path in high tropospheric conditions. The species providing no detectable signal have been excluded from the chart.

6.8.2 Chain 1

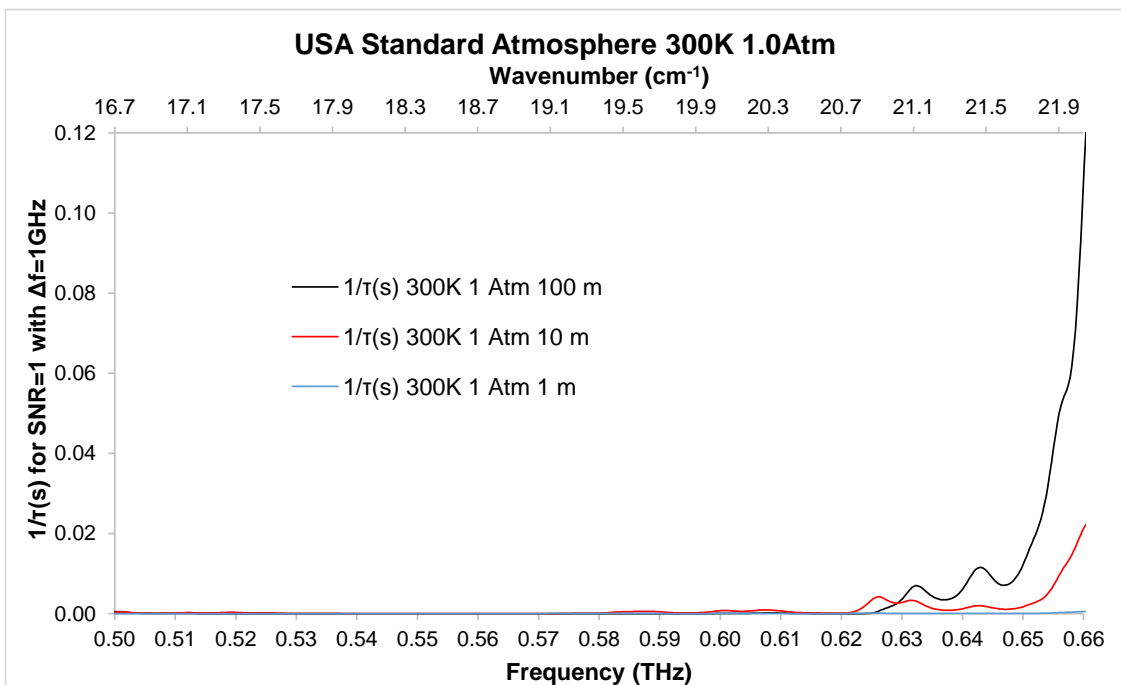

Fig. 6.15: Maximum sampling rate for chain 1 for having $SNR = 1$ and $\Delta\nu = 1$ GHz for a path of, respectively, 1m, 10m, 100m in a homogeneous medium, as in Fig. 6.12. The chart has been generated using a standard atmosphere at 300K and 1.0 Atm pressure (sea level conditions).

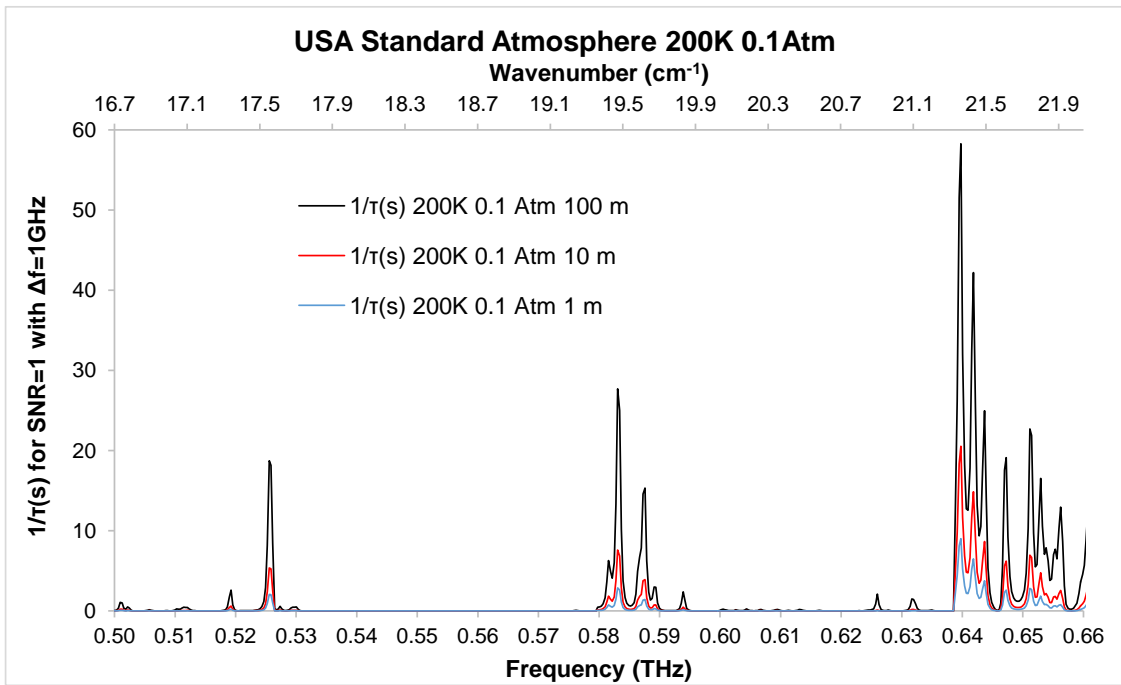

Fig. 6.16: Maximum sampling rate for chain 1 for having $SNR = 1$ and $\Delta\nu = 1 \text{ GHz}$ for a path of, respectively, 1m , 10m , 100m in a homogeneous medium, as in Fig. 6.12. The chart has been generated using a standard atmosphere at 200K and 0.1 Atm pressure (high tropospheric conditions).

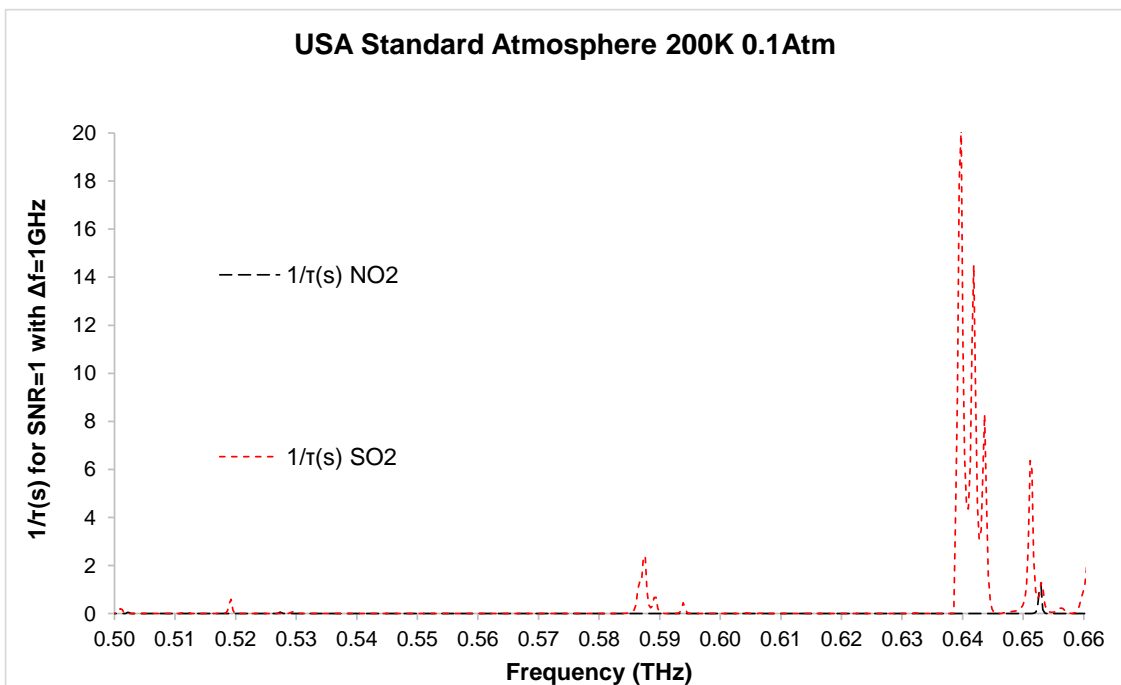

Fig. 6.17: Maximum sampling rate for the species observed by Chain 1 instrument for a 10 m path in high tropospheric conditions. The species providing no detectable signal have been excluded from the chart.

6.8.3 Chain 2

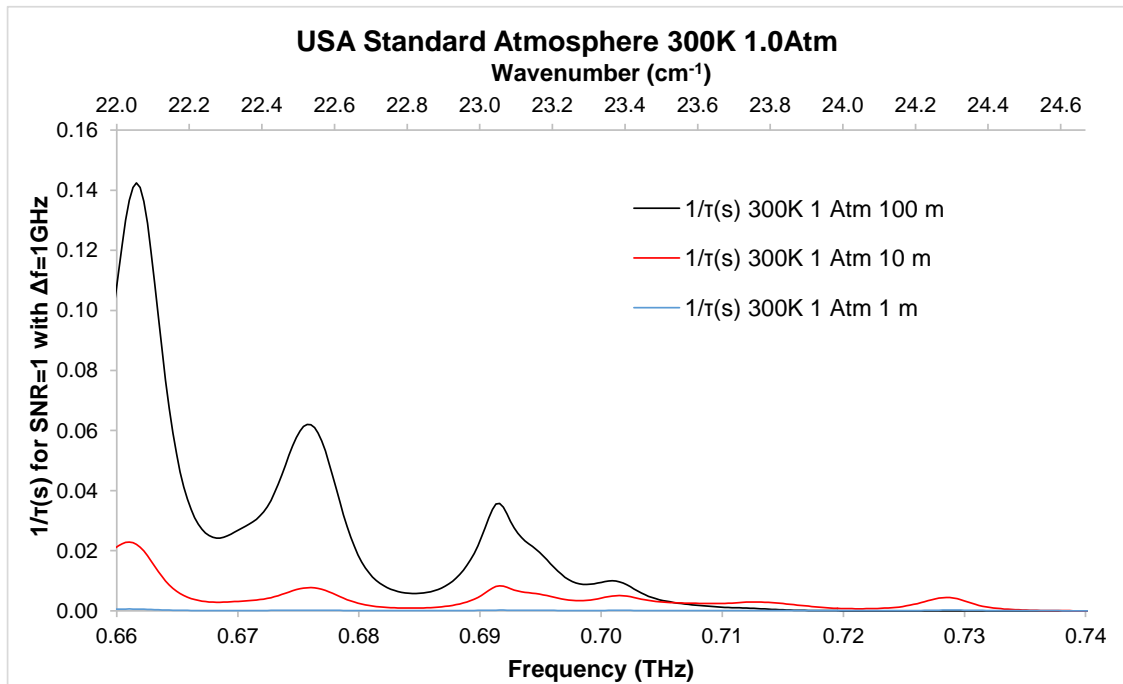

Fig. 6.18: Maximum sampling rate for chain 2 for having $SNR = 1$ and $\Delta\nu = 1 GHz$ for a path of, respectively, 1m, 10m, 100m in a homogeneous medium, as in Fig. 6.12. The chart has been generated using a standard atmosphere at 300K and 1.0 Atm pressure (sea level conditions).

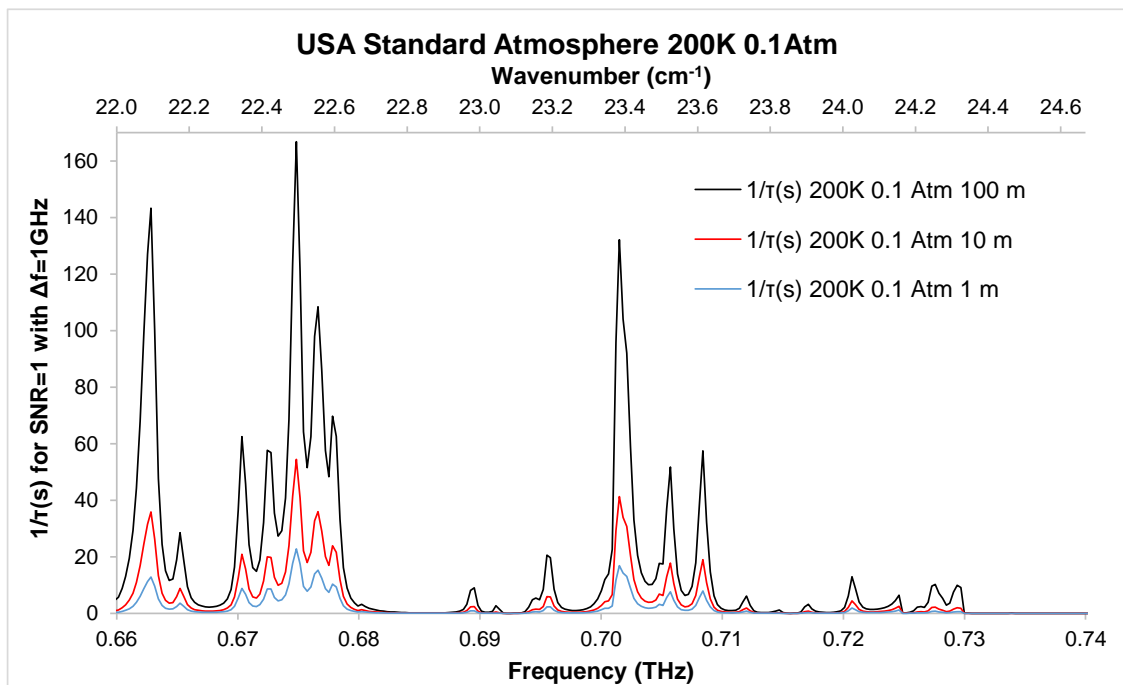

Fig. 6.19: Maximum sampling rate for chain 2 for having $SNR = 1$ and $\Delta\nu = 1 GHz$ for a path of, respectively, 1m, 10m, 100m in a homogeneous medium, as in Fig. 6.12. The chart has been generated using a standard atmosphere at 200K and 0.1 Atm pressure (high tropospheric conditions).

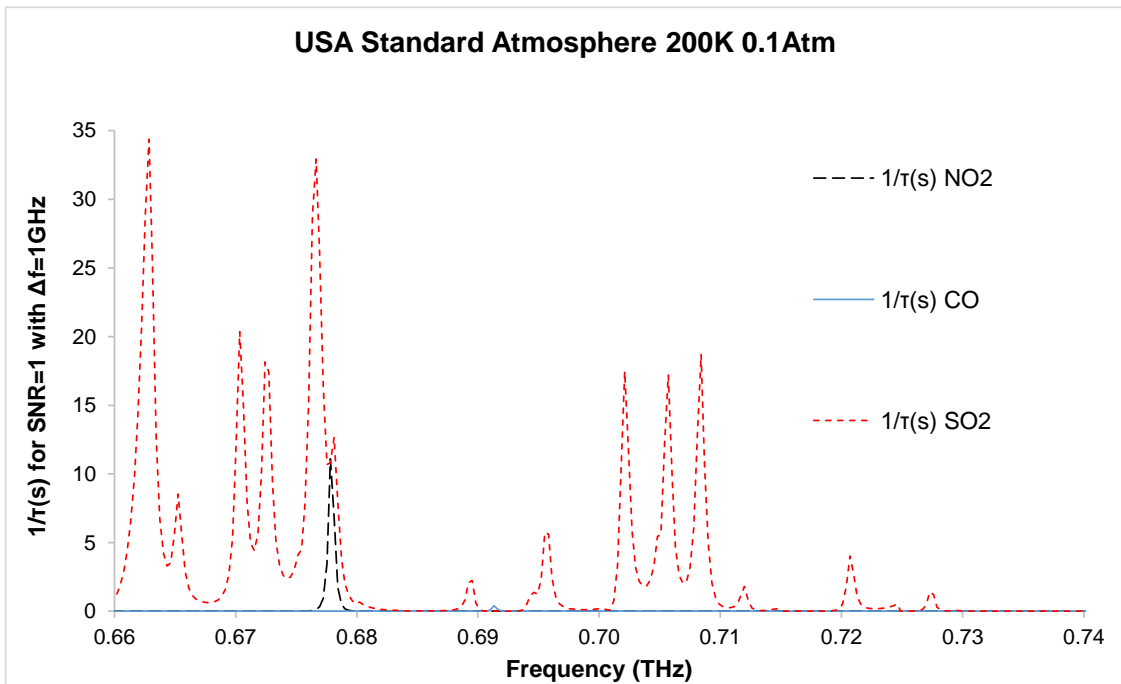

Fig. 6.20: Maximum sampling rate for the species observed by Chain 2 instrument for a 10 m path in high tropospheric conditions. The species providing no detectable signal have been excluded from the chart.

6.8.4 Chain 3

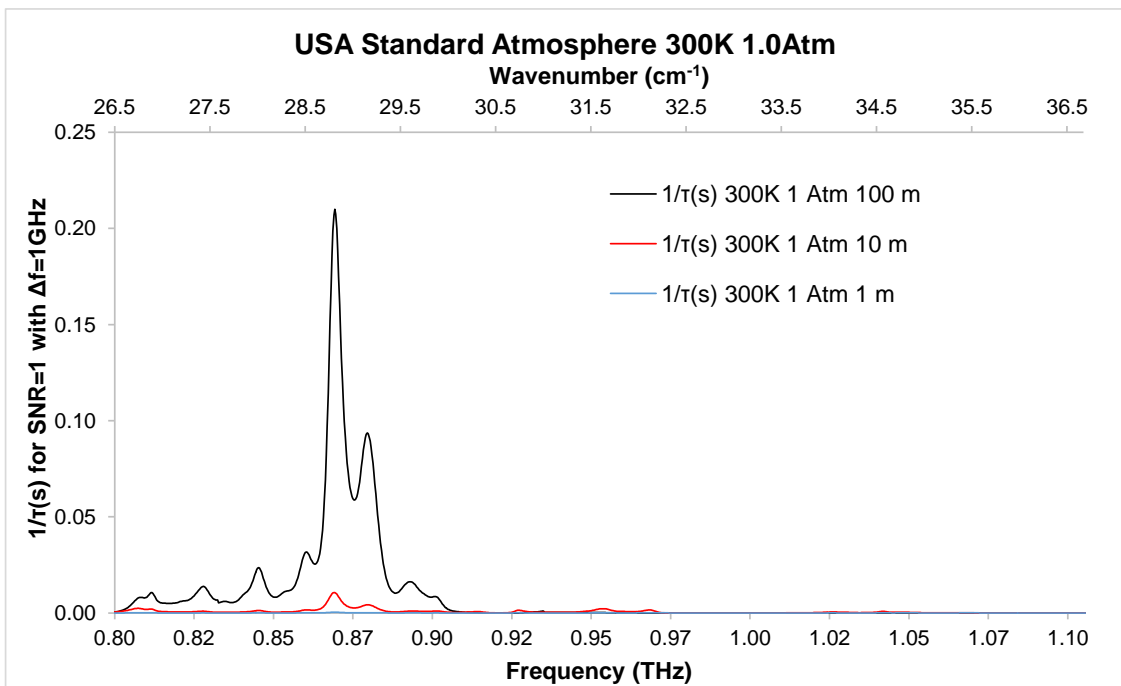

Fig. 6.21: Maximum sampling rate for chain 3 for having $SNR = 1$ and $\Delta\nu = 1\text{GHz}$ for a path of, respectively, 1m, 10m, 100m in a homogeneous medium, as in Fig. 6.12. The chart has been generated using a standard atmosphere at 300K and 1.0 Atm pressure (sea level conditions).

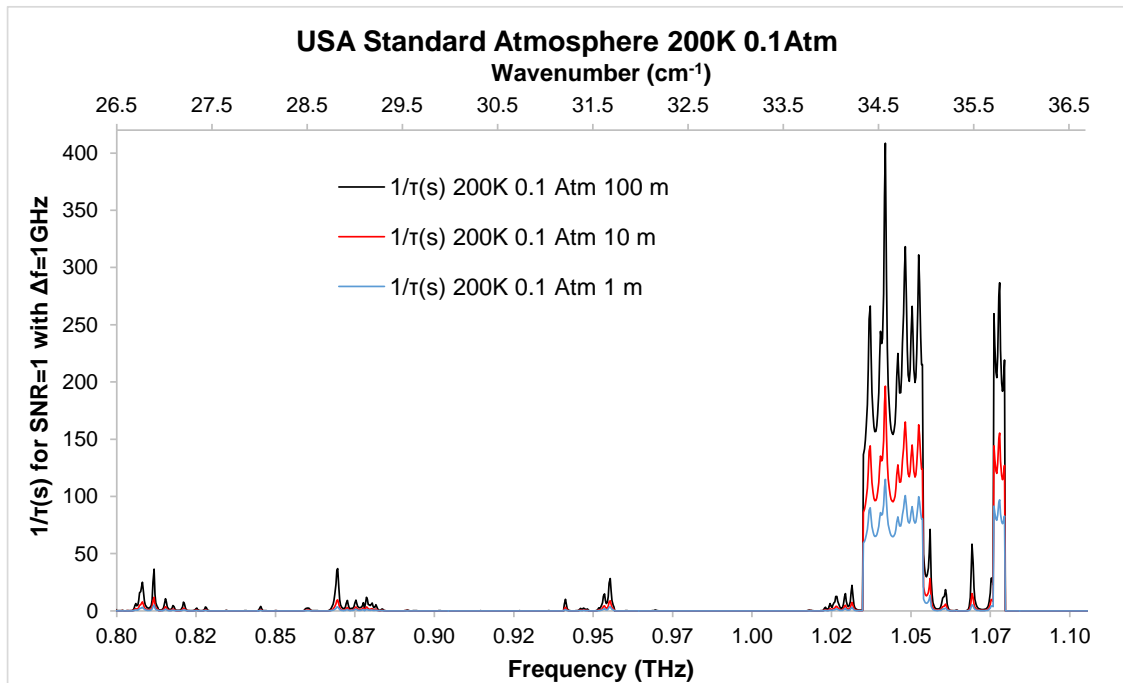

Fig. 6.22: Maximum sampling rate for chain 3 for having $SNR = 1$ and $\Delta\nu = 1$ GHz for a path of, respectively, 1m, 10m, 100m in a homogeneous medium, as in Fig. 6.12. The chart has been generated using a standard atmosphere at 200K and 0.1 Atm pressure (high tropospheric conditions).

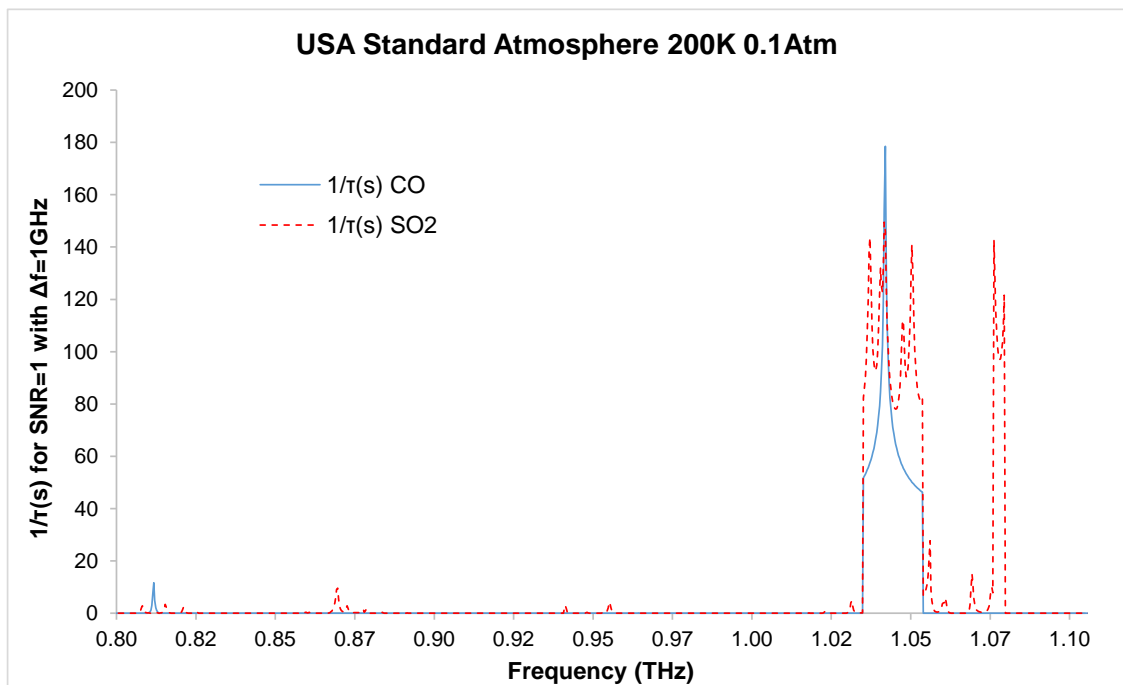

Fig. 6.23: Maximum sampling rate for the species observed by Chain 3 instrument for a 10 m path in high tropospheric conditions. The species providing no detectable signal have been excluded from the chart.

6.9 Signal conditioning on detection chain

For determining the characteristics of an amplifier the Noise figure NF and the noise factor F are introduced as measures of degradation of the signal-to-noise ratio (SNR), caused by components in a radio frequency (RF) signal chain. The noise factor is defined as the ratio, at standard noise temperature T_0 (usually 290 K), of the output noise power of a device to the output noise power attributable only to thermal noise in the input termination:

$$F = \frac{SNR_{in}}{SNR_{out}}$$

The noise figure is the noise factor expressed in decibels:

$$NF = 10 \log_{10} F = SNR_{in}(dB) - SNR_{out}(dB)$$

In heterodyne systems, the output noise power includes also the contributions from image-frequency transformation, but the portion attributable to thermal noise in the input termination at standard noise temperature includes only the contribution of the principal frequency transformation of the system and excludes the other contributions from image frequency transformation.

Noise temp (K)	F	NF
0	1.00	0.0
35	1.12	0.5
75	1.26	1.0
120	1.41	1.5
170	1.58	2.0
226	1.78	2.5
289	2.00	3.0
359	2.24	3.5
438	2.51	4.0
527	2.82	4.5
627	3.16	5.0
739	3.55	5.5
865	3.98	6.0
1005	4.47	6.5
1163	5.01	7.0
1341	5.62	7.5
1540	6.31	8.0
1763	7.08	8.5
2014	7.94	9.0
2295	8.91	9.5
2610	10.00	10.0

Tab. 6.1: different values of the noise temperature calculated for the corresponding values of the noise figure and noise factor at ambient temperature (290 K).

F is related to the noise temperature by:

$$F = 1 + \frac{T_{rx_i}}{T_0}$$

If several devices are connected in cascade, the total noise factor is given by the Friis' Formula (the same as in par. 6.4):

$$F = F_1 + \frac{F_2 - 1}{G_1} + \frac{F_3 - 1}{G_1 G_2} + \dots + \frac{F_n - 1}{G_1 G_2 \dots G_{n-1}}$$

where F_i is the noise factor for the i -th device and G_i is the power gain (linear) of the i -th device. The first amplifier in a chain has the most significant effect on the total noise figure than any other amplifier in the chain. The lower noise figure amplifier must go first in the conditioning line.

So, given NF_i (I.e. from the device datasheet), the equivalent noise temperature T_i can be expressed as:

$$T_i = T_0 \left(10^{\frac{NF_i}{10}} - 1 \right)$$

7 Conclusions

This report shows, in the framework of DIAST project, different examples of instruments in the range of frequency of interest:

- 2695 - 2705 GHz for Chain 0 (involving a QCL as local oscillator);
- 500 - 660 GHz for Chain 1 (with custom and commercial components);
- 660 - 740 GHz for Chain 2 (with custom and commercial components);
- 795 - 1100 GHz for Chain 3 (with custom and commercial components).

The estimate of the instrumental characteristic SNR has been performed for different line of sight in typical working scenarios as a function of the integration time and bandwidth. For each instrument, the maximum sampling rate for having a minimum SNR equal to unity (at least 1 bit of information) is reported for the main pollutants of interest that can be observed in the instrument frequency range.

The integration time (expressed in seconds) needed for observing each species with a SNR of 100 (at 200 K and 0.1 atm) is reported in the following table for each proposed instrument (chain 0 to 3).

Species	Chain 0	Chain 1	Chain 2	Chain 3
OH	2.0	-	-	-
HCL	2.9	-	-	-
SO2	-	5	3	0.7
NO2	-	100	10	-
CO	-	-	-	0.6

Tab. 7.1: Integration time (expressed in seconds) needed for observing a molecular species with a SNR of 100 at 200 K and 0.1 atm.

