

IL NUOVO CIMENTO
DOI 10.1393/ncc/i2008-10287-3

VOL. 31 C, N. 2

Marzo-Aprile 2008

On the current circulation about a high-voltage s/c: Two more case-studies by the TSS-1R tethered satellite mission

F. MARIANI⁽¹⁾(*), S. ORSINI⁽²⁾, M. CANDIDI⁽²⁾, M. F. MARCUCCI⁽²⁾,
M. ACUÑA⁽³⁾, G. MUSMANN⁽⁴⁾ and N. F. NESS⁽⁵⁾

⁽¹⁾ *Dipartimento di Fisica, Università "Tor Vergata" - Rome, Italy*

⁽²⁾ *INAF-CNR Istituto di Fisica dello Spazio Interplanetario - Rome, Italy*

⁽³⁾ *NASA/GSFC - Greenbelt, MD 20771, USA*

⁽⁴⁾ *Technische Universität Braunschweig - Braunschweig, Germany*

⁽⁵⁾ *University of Delaware - Newark, Delaware, USA*

(ricevuto il 3 Marzo 2008; approvato il 30 Marzo 2008; pubblicato online il 22 Settembre 2008)

Summary. — Magnetic field observations by the TEMAG experiment on the TSS-1R satellite for two events of constant stimulated current along the tether are discussed. Previous evidence of a complex, unexpected, electric azimuthal current circulation in close proximity of the high-voltage spacecraft is further supported and complemented. While previous events cover time intervals shorter than a spin cycle, the two new ones allow a complete coverage for a full spin cycle. The need of deeper theoretical approach as well as of more experimental observations is stressed.

PACS 94.30.Ms – Magnetic pulsations.

PACS 07.55.Ge – Magnetometers for magnetic field measurements.

1. – Introduction

In two recent papers ([1], hereafter indicated as paper M; [2]) the pattern of current circulation around the TSS-1R satellite was studied during 8 sequences of active pulsed currents. The study was TEMAG experiment observation of the small signatures impressed on the local magnetic field by the active electric current. The TSS-1R s/c was flown in February 1996 on a nearly circular orbit at 294 km altitude and 28.5 degree inclination. The TEMAG experiment consisted of two tri-axial sensors, mounted on a 87 cm long boom, as shown in paper M. Peculiar signatures, superimposed to the background geomagnetic field and consistently related to the boom orientation were seen. The temporal duration of each sequence was a fraction of the spin period, while the intervals of non-zero current were randomly distributed. This made it possible to build a first-order

(*) E-mail: franco.mariani@roma2.infn.it

model of the current flow all around the spinning tethered satellite, close to its equatorial plane. The magnetic field signatures, as seen over different intervals of spin angle α (α is the angle of the boom with respect to the ram direction, $\alpha = 0$ being the ram direction) during the 8 events gave consistent evidence of a nearly equatorial sector of current flowing on the ram hemisphere of the ionospheric environment at a distance of several tens cm ahead of the s/c skin. When the boom was pointing to anti-ram hemisphere no significant current flow effect on the magnetic field was detectable, even when the stimulated current was on; this fact led us to suggest that the electric circuit closure toward the s/c skin was via a distributed current diluted enough to become undetectable over the local background magnetic field.

This peculiar pattern of current circulation deviates drastically from any simple model of ionospheric electrons collection, either more or less radial, or along the geomagnetic field lines toward the high voltage s/c. Available model studies describe reasonably well what happens at quite some distance ahead of a spherical (or nearly spherical) s/c in the plasma environment; but they are not adequate to describe the physical situation, at least in close proximity of non-spherically symmetric s/c. The collected current was actually significantly higher than predicted. More recent simulations and theoretical studies for the case of spherical charged bodies have been able to explain the higher current, as seen in both TSS-1 and TSS-1R missions. They also show that while the current flows parallel to the magnetic field line at large distance from the satellite it gives way to azimuthal and radial current in the RAM volume ahead of the spherical skin [3].

In the specific case of the TSS satellites one has also to expect, and indeed it has been observed, some drastic change of the local current collection mechanism, as a consequence of the presence of the boom (or more generally, of a non-spherical s/c symmetry), as well as of the deviating anisotropic effects of the geomagnetic field.

This implies that on the one side we need to rely on more experimental studies to extend the rather poor statistics (due to the short duration of the TSS missions) and, on the other side, on deeper study of the plasma behavior at small, quasi-microscopic, scale.

In this paper we discuss two additional events, when a constant active current was injected along the conducting tether for a time interval longer than a full spin period. This complements our previous study [1] in that now the non-zero current intensity during the s/c rotation allows uninterrupted observation of the magnetic signatures at TEMAG location, whichever the boom (and sensors) orientation, not only in correspondence to the relatively short time duration of individual sequences of pulsed non-zero current.

In sect. 2 we describe and discuss the observational data for the two events, while sect. 3 summarizes the conclusions.

2. – The observational data

Figure 1 shows a sketch of the magnetic field experiment reference system, where Z is pointing vertically downward, X is pointing radial toward the spin axis and Y is the third axis pointing anti-clockwise. Figure 2 shows the differences $B_x - B_{xm}$, $B_y - B_{ym}$ and $B_z - B_{zm}$ of the observed X , Y and Z field components of the field observed at the outboard (upper thick line) and at the inboard sensor (lower thin line) and those predicted for the local geomagnetic field by the appropriate IGRF95 model [4,5] on the s/c orbit, for the two events E1 and E2 (table I).

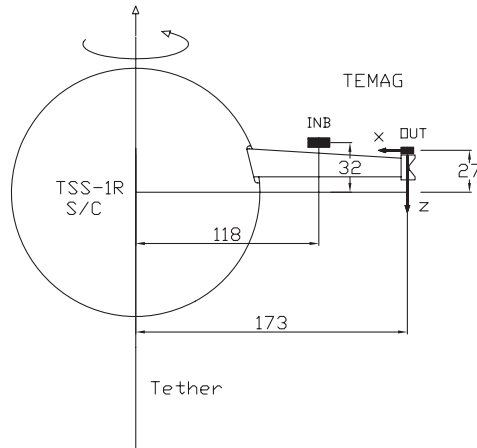

Fig. 1. – A sketch of the TEMAG instrument and of its geometrical reference system.

The units on the plots are the same as those used in paper M, *i.e.*: the differences between the IGRF95 components and the measured ones. The background, similar and rather large, excursion of the field at the two sensors is indicative of the significant discrepancy between the true geomagnetic field and the smoothed IGRF95 model estimates

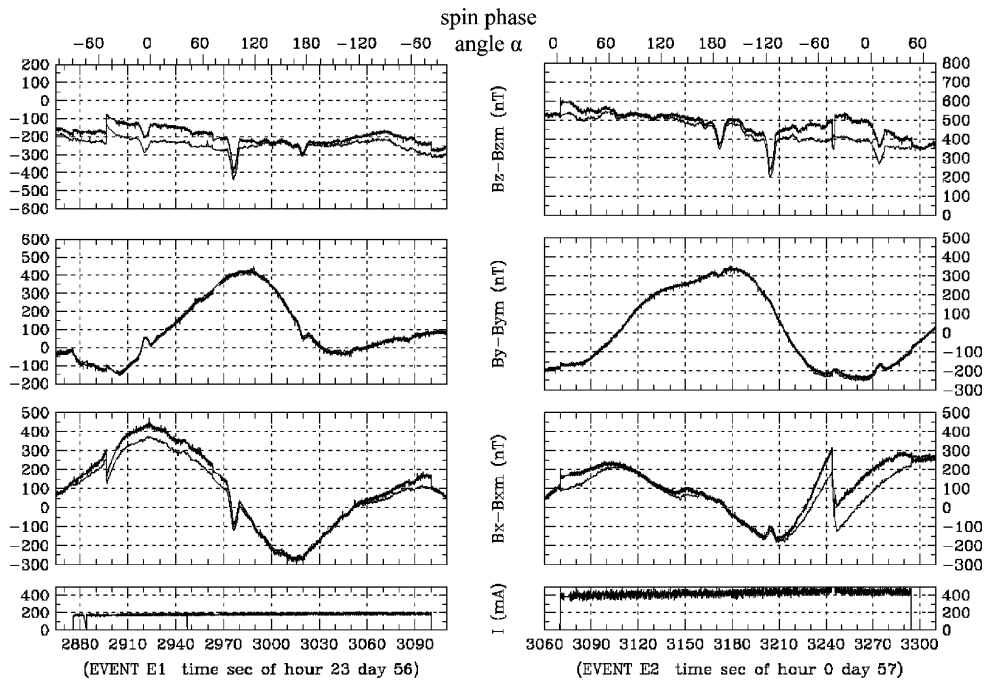

Fig. 2. – Top to bottom panels: observed trends of the magnetic field components at the outboard (thick lines) and inboard (thin lines) sensors, during the events E1 and E2. The plots show the difference between the IGRF95 values and the measured ones. The bottom plot shows the current intensity I injected along the tether. The top scale of each set of plots shows the spin angle α of the boom with respect to the ram direction.

TABLE I. – *Event list.*

Day	Start time (h:min:s)	End time (h:min:s)	I (mA)
56	234756	235136	200
57	005110	005454	400

at s/c altitudes. The rather large wave seen on X and Y components may partially be a spin effect due to the modulation by solar radiation on the s/c surface. However, any such effect would similarly affect inboard and outboard field components, with no effect on the differences as shown in the figure. Clear field signatures are impressed on the diagram of outboard and inboard components. We cannot simply look at really simultaneous individual differences among the two sensors components, because of the fact that inboard and outboard sample the field at different times and with different temporal resolution. Some abrupt jumps, simultaneous on both sensors (for example at $t = 2900$ s of event E1 and $t = 3245$ s of event E2) are artifacts consequent to sudden not infrequent small automatic readjustments of the s/c spin angle necessary to maintain the nominal constant s/c spin rate.

Basically, the pattern of the differences seen in the two figures is quite similar to that we have seen in paper M. Even now, with a constant active current flowing along the tether, no significant difference out of the noise background is detectable on the B_y components at the two sensors' locations. As concerns the B_x and B_z components, instead, significant differences are observed, essentially when the boom is spanning the ram side hemisphere, *i.e.* when its orientation with respect to the ram direction, is approximately contained inside the interval -90 to $+90$ degrees; the amplitude of the differences is roughly proportional to the current intensity during the two events. The maximum difference on the X and Z outboard and inboard components exceeds 100 nT during E2 and is more or less one half of that during E1.

Some less evident peculiar features are also seen in fig. 2, in particular the lack of significant jumps of inboard $B_x - B_{xm}$ and $B_z - B_{zm}$ at the current switch-on/off during E1, while, during E2 both $B_z - B_{zm}$ and $B_x - B_{xm}$ show a jump of opposite sign. Some similar peculiarities were indeed also noticed in a couple of events of paper M; they are clear indications of a small-scale structure of the field.

As a whole, we have again observational evidence that also in these two events a toroidal current flow ahead of the s/c on the ram hemisphere is apt to describe the observed trends. We must be aware that the model, as outlined in paper M and confirmed here, is only a first-order, rough, description. Unfortunately, as a matter of fact, our data are still the only available direct information we have on the real current circulation in close proximity of a high-voltage s/c. Interpretation of the differences shown in fig. 2 is subject, here and in paper M as well, to an intrinsic physical limitation. While the observed magnetic perturbation is shown to be the effect of an azimuthal current flowing ahead of the s/c on its equatorial plane, the actual current density cannot be determined. The magnetic perturbation at TEMAG is an integral effect of the current density distribution with radial distance; no inference can be made from this integral measurement, on the actual distribution of current in the plasma. In this paper, similarly to what we did in paper M, we assume an equatorial concentrated current with the same intensity

TABLE II. – *Angular intervals.*

	Event E1	Event E2
ψ_1 (deg)	–120	–90
ψ_2	100	60
r_0 (cm)	200	200

as the current flowing along the tether, as shown in the bottom panels of fig. 2. As a necessary consequence, full qualitative comparison with the predictions from simulations is not possible; it is however important to remark that observations and predicted existence of azimuthal current flow on the RAM side of the s/c environment qualitatively agree.

With these limitations in mind, we tried to test a best match approach using a simple set of simple parameters, as shown in table II. The accompanying figure 3, adapted from paper M, illustrates the geometry.

Figure 4 shows the differences among the computed B_x , B_y and B_z field components at the two sensors using the values shown in the table. The trends seen in the figure match reasonably well those inferred from fig. 2. Any variation of the values of table II, in the order of 10 degrees or so, while obviously leads to somewhat different results, does not however significantly affect the shape of the physical features.

So, as a whole, the phenomenology observed during the two new events is substantially similar to that observed in the 8 events of active, pulsed current discussed in M. The existence of a thoroidal current flow ahead of the s/c when the boom points on the ram side hemisphere is also applicable to these two new events, and this adds confidence to the current pattern model we propose. Also in this case the lack of detectable signatures on the observed field in the anti-ram hemisphere is an obstacle to get some more hint on the diluted current pattern in the s/c wake and its final precipitation toward the s/c skin before flowing away along the conducting tether.

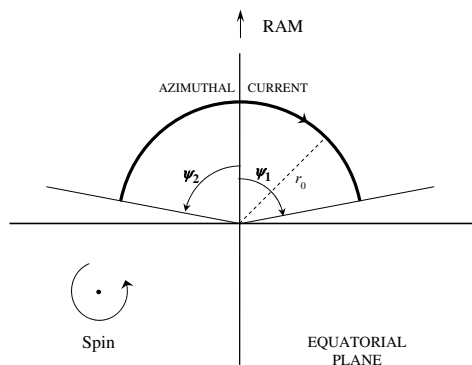

Fig. 3. – The equatorial projection of a clockwise azimuthal current, flowing between azimuthal angles ψ_2 and ψ_1 at radial distance r_0 .

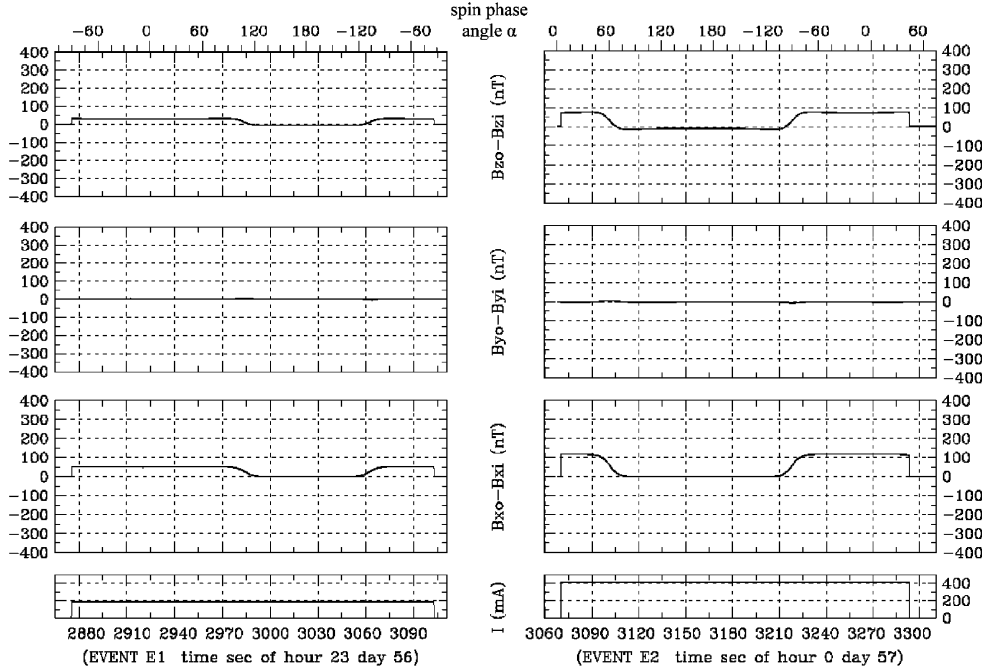

Fig. 4. – Top to bottom panels: differences between outboard and inboard field components, as computed for the best match values of angles ψ_1 and ψ_2 and distance r_0 . The bottom plots show the current intensity I . The top scale of each set of plots shows the spin angle α of the boom with respect to the ram direction.

3. – Conclusions

The results discussed in this paper complement and confirm the conclusions outlined in paper M. The relatively simple models describing current collection in the ionosphere by nearly spherical high-voltage s/c are valid beyond some distance well ahead of the s/c, of the order of its geometrical size. But in its close proximity a very complex current circulation pattern builds up, strongly affected by the geometrical shape of the s/c system, in our specific case of TSS-1R mainly by the boom.

Any mapping and description, or practical application, of electric currents captured by a high-voltage s/c and channeled toward a conducting tether cannot rely on a macroscopic scale. It must rather be based on a still missing quasi-microscopic scale theoretical study of the plasma, in close proximity to the actual conducting s/c surface. On the other hand, the limited available statistics (due to the short duration of the TSS missions) requires further experimental observations to better describe and understand the ionospheric electron collection and circulation under different physical conditions and geometries.

* * *

The TSS missions were a joint Italy-USA venture. Support by Italian Space Agency ASI and by NASA, as well as by German DLR is gratefully acknowledged. We like to thank once again all the TSS team and the many colleagues who contributed during many years of hard work to the success of the TSS innovative missions. We thank S. ZAMPIERI for manuscript editing and camera-ready preparation.

REFERENCES

- [1] MARIANI F., ORSINI S., CANDIDI M., MARCUCCI M. F., ACUÑA M., MUSMANN G. and NESS N. F., *J. Geophys. Res.*, **105** (2000) 18537.
- [2] MARIANI F., CANDIDI M., ORSINI S., TERENCE R., AGRESTI R., MUSMANN G., RAHM M., ACUÑA M., PANETTA P., NESS N. F. and NEUBAUER F., *Geophys. Res. Lett.*, **25** (1998) 425.
- [3] SINGH N., LEUNG W. C. and SINGH G. M., *J. Geophys. Res.*, **105** (2000) 20935.
- [4] LANGEL R. A., *J. Geomagn. Geoelectr.*, **43** (1991) 1007.
- [5] BARTON C. E., *EOS Trans.*, **77** (1996) 16.