

---

UNIVERSIDAD CARLOS III DE MADRID



ESCUELA POLITÉCNICA SUPERIOR

# Design, Construction, Monitoring & Control of a Mock-up Building Module for Testing New Components and Systems

*Diseño, Construcción, Monitorización y Control de un Módulo Prototipo de  
Edificación para Ensayo de Nuevos Componentes y Sistemas*

---

Proyecto Fin de Carrera

Ingeniería Industrial

**Autor: Raúl Sánchez Labrador**

---

Departamento de Ingeniería de Sistemas y Automática

Tutor: Santiago Martínez de la Casa Díaz

Leganés, Enero de 2011

# Table of contents

---

Data of the project.....	v
Datos del proyecto .....	v
Acknowledgments .....	vi
Agradecimientos .....	vi
Foreword.....	viii
Prefacio.....	viii
Summary.....	x
Resumen.....	x
List of Figures.....	xiv
List of Tables.....	xviii
<b>1 Introduction .....</b>	<b>1</b>
1.1 General objectives of this PFC .....	2
1.2 I3CON R&D Project Demonstration Activities.....	3
1.2.1 Motivations.....	3
1.2.2 Tasks .....	3
1.3 The Mock-up Demonstrator.....	5
1.3.1 Presentation of the proposal.....	5
1.3.2 The I3CON Mock-up Mission.....	7
1.3.3 I3CON Mock-up Services and Business Models.....	9
1.4 Specific Mock-up objectives .....	11
1.4.1 Partners' specifications.....	11
1.4.2 Façade panels .....	12
1.4.3 Roof .....	12
1.4.4 Under-floor radiant heating .....	12
1.4.5 Piping and Water saving system .....	12
1.4.6 Fire extinguishing system .....	13
1.4.7 Multi-Services Trunking System .....	13
1.4.8 Solar energy systems .....	14
1.4.9 Electro-chromic glazing .....	14
1.4.10 Wireless sensor network and associated sensors.....	15
1.4.11 Mock-up control system and metering devices .....	15
1.4.12 Mobile productivity tools .....	15
1.4.13 Objectives fulfilled with the construction in itself.....	16
1.4.14 Sustainability.....	17
<b>2 Design of the Mock-up components .....</b>	<b>18</b>
2.1 Structure .....	20
2.1.1 Floor/Ceiling slab .....	20
2.1.2 Roof covering.....	21
2.2 Façade panels and partition walls .....	23
2.2.1 Façade design parameters.....	23

2.2.2	The Sandwich Framex concept .....	25
2.2.3	Façade panel typologies .....	27
2.2.4	Façade panels performance .....	34
2.3	Piping, water saving and fire extinguishing systems .....	40
2.3.1	Hot water system .....	40
2.3.2	Cold water system & residential sprinklers .....	42
2.4	Under-Floor Heating (UFH) .....	43
2.5	Electro-Chromic Glazing Unit (ECGU) .....	45
2.6	Auxiliary Systems (HVAC Equipment) .....	50
2.7	Multi-Services Trunking System (MSTS) .....	51
<b>3</b>	<b>Monitoring &amp; Control systems .....</b>	<b>53</b>
3.1	Monitoring & Control signals .....	54
3.2	Building Operating System (BOS) .....	62
3.2.1	Control signals & wiring scheme .....	62
3.2.2	BOS Equipment .....	65
3.2.3	Electrical equipment .....	66
3.2.4	Metering devices .....	68
3.3	Wired Sensors .....	70
3.3.1	Outdoor sensors .....	70
3.3.2	Sensors deployed at the façade panels .....	70
3.3.3	Wired indoor sensors .....	74
3.3.4	Water temperature and flow .....	75
3.4	Wireless Sensor Network .....	77
3.4.1	C&P: CO <sub>2</sub> & Presence .....	77
3.4.2	HLT: Humidity, Light & Temperature .....	79
3.4.3	Base station .....	80
3.4.4	Gateway and web server .....	80
3.4.5	Operation of the WSN .....	80
3.5	ICT requirements for remote access & control .....	82
3.6	Mobile Productivity Tools .....	85
3.6.1	Objectives and planned demonstration activities .....	85
3.6.2	RFID Tags deployment .....	86
<b>4</b>	<b>Construction: Components manufacturing &amp; assembly and Systems installation .....</b>	<b>88</b>
4.1	Construction of the Mock-up structure .....	90
4.1.1	Floor slab + Metallic structure .....	90
4.1.2	Roof deck .....	91
4.2	Façade panels .....	93
4.2.1	GRC Stud-frame panels with embedded glass blocks (P-01 & P-11) .....	94
4.2.2	Pyramidal GRC shells + PCM Plasterboards + ECGU (P-02 & P-10) .....	94
4.2.3	Sandwich Framex with PCM Boxes (P-03 & P-09) .....	95
4.2.4	Sandwich Framex with vegetated panels (P-04 & P-08); Watering system .....	97

4.2.5	Façade panels with improved acoustical features (P-05 & P-07).....	101
4.2.6	Eastern and Western Fronts (P-06 & P-12).....	102
4.3	Piping system.....	103
4.3.1	Tee system Vs Manifold system.....	103
4.3.2	Installation of the recirculation and fire extinguishing systems.....	104
4.4	Installation of the Under Floor Heating system.....	105
4.5	Assembly of the ECGU, and lighting strategies.....	106
4.6	Installation of the auxiliary HVAC Systems.....	110
4.7	Multi-Services Trunking System.....	111
4.8	WSN Deployment.....	114
4.9	Wiring and net-working.....	115
4.10	Mobile productivity tools.....	116
<b>5</b>	<b>Measurements Plan for demonstration of R&amp;D results.....</b>	<b>117</b>
5.1	Constructability.....	118
5.1.1	PCM-enhanced plasterboards.....	118
5.1.2	Modularity of the Sandwich Framex façade.....	118
5.1.3	Manufacture of a GRC Sandwich panel with PCM packed in the core.....	118
5.1.4	Vegetated modules development & installation onto Sandwich Framex.....	119
5.1.5	Manufacture of improved plasterboard prototype.....	120
5.2	Start-up tests for the singular systems.....	121
5.2.1	Services delivery through the MSTs.....	121
5.2.2	Water saving system.....	121
5.2.3	Fire extinguishing system.....	122
5.2.4	Analysis of thermal bridges throughout the Mock-up envelope.....	122
5.2.5	Acoustical behaviour.....	122
5.3	Thermal performance of the different envelope solutions and passive systems.....	124
5.3.1	Boundary conditions and thermal insulation.....	124
5.3.2	Comparison of the different rooms envelopes thermal performance.....	124
5.3.3	Stabilization of the indoor temperature by means of passive systems.....	125
5.4	Usage scenarios and measurement times.....	126
5.4.1	Summer time measurements.....	126
5.4.2	Autumn time measurements.....	127
5.4.3	Winter time measurements.....	127
5.4.4	Calendar.....	128
<b>6</b>	<b>Conclusions.....</b>	<b>130</b>
6.1	Developed components and systems overview.....	132
6.2	Discussions and pending issues – further work.....	137
6.2.1	Manufacture of GRC Sandwich panels with PCM packed in the core.....	137
6.2.2	Improved plasterboard prototype.....	137
6.2.3	Solar systems + PCMs.....	138
6.2.4	Outdoor Weather Station (OWS).....	138
6.2.5	IFC model.....	139

6.2.6	Conclusions of the measurements campaign and other analyses .....	139
<b>7</b>	<b>References and glossary.....</b>	<b>140</b>
7.1	References.....	141
7.2	Glossary of terms and acronyms .....	147
<b>I.</b>	<b>Appendix I: Mock-up Drawings.....</b>	<b>156</b>
I.1	Appendix I.1: Architectural Drawings.....	156
I.2	Appendix I.2: Engineering Drawings.....	157
I.2.1	Structure .....	157
I.2.2	Plumbing.....	157
I.2.3	Drainage .....	157
I.2.4	HVAC.....	157
I.2.5	Electricity and Control System.....	158
<b>II.</b>	<b>Appendix II: Schedule.....</b>	<b>159</b>
<b>III.</b>	<b>Appendix III: Datasheets .....</b>	<b>160</b>
III.1	BOS .....	160
III.1.1	Cable & Light.....	160
III.1.2	LON .....	160
III.1.3	Meters .....	160
III.1.4	Tags.....	160
III.2	FAÇADES.....	161
III.2.1	Claddings .....	161
III.2.2	ECGU.....	161
III.2.3	Frames & Panels.....	161
III.2.4	Plasterboards .....	161
III.2.5	Watering System.....	161
III.3	HVAC.....	161
III.3.1	Air Conditioning.....	161
III.3.2	Pumps & Valves.....	162
III.3.3	Solar Systems .....	162
III.3.4	Underfloor Heating .....	162
III.4	INSULATION .....	162
III.5	SENSORS .....	163
III.5.1	Wired.....	163
III.5.2	Wireless .....	163
<b>IV.</b>	<b>Appendix IV: Bill of Materials.....</b>	<b>164</b>
<b>V.</b>	<b>Appendix V: Cabling .....</b>	<b>165</b>

## Data of the project

**Title:** Design, Construction, Monitoring & Control of a Mock-up Building Module for Testing New Components and Systems

**Language:** English, summary in Spanish

**Author:** Raúl Sánchez Labrador  
[100025555@alumnos.uc3m.es](mailto:100025555@alumnos.uc3m.es)

**Degree:** Industrial Engineering

**Speciality:** Machines and Structures

**University:** Universidad Carlos III de Madrid  
[www.uc3m.es](http://www.uc3m.es)

**Department:** Automatic and Systems Engineering  
[balaguer@ing.uc3m.es](mailto:balaguer@ing.uc3m.es)

**Academic Tutor:** Santiago Martínez de la Casa  
[scasa@ing.uc3m.es](mailto:scasa@ing.uc3m.es)

**Partner company:** Dragados S. A., R&D Directorate, R&D Projects in Building and Processes Service

**Industrial tutor:** Miguel J. Segarra Martínez  
[mjsegarra@dragados.com](mailto:mjsegarra@dragados.com)

## Datos del proyecto

**Título:** Diseño, Construcción, Monitorización y Control de un Módulo Prototipo de Edificación para Ensayo de Nuevos Componentes y Sistemas

**Idioma:** Inglés, resumen en Español

**Autor:** Raúl Sánchez Labrador  
[100025555@alumnos.uc3m.es](mailto:100025555@alumnos.uc3m.es)

**Titulación:** Ingeniería Industrial

**Especialidad:** Máquinas y Estructuras

**Universidad:** Universidad Carlos III de Madrid  
[www.uc3m.es](http://www.uc3m.es)

**Departamento:** Ingeniería de Sistemas y Automática [balaguer@ing.uc3m.es](mailto:balaguer@ing.uc3m.es)

**Tutor académico:** Santiago Martínez de la Casa  
[scasa@ing.uc3m.es](mailto:scasa@ing.uc3m.es)

**Empresa colaboradora:** Dragados S. A., Dirección de I+D, Servicio de Proyectos I+D en Edificación y Procesos

**Tutor industrial:** Miguel J. Segarra Martínez  
[mjsegarra@dragados.com](mailto:mjsegarra@dragados.com)

## Acknowledgments

This Final Project was carried out during two and a half years of collaboration with the Department of Automatic and Systems Engineering, where I worked as a part-time researcher for the “RoboticsLab”. I would like to express my gratitude for the opportunity I was given to participate in the European R&D Project *Industrialised, Integrated, Intelligent Construction* (I3CON). Great part of this challenging project’s success is due to the University’s commitment to join together academic research and industrial development. Thanks are due to all the staff in the “RoboticsLab” for their support and especially to Carlos Balaguer who, even being Research Vice-chancellor, would always have time and encouraging words for the students. And, of course, thanks a lot to my tutor, Santiago Martínez de la Casa, who always trusted on me and was very flexible in his tutelage.

Most of the work was done at Dragados’ offices, where I reported to the R&D Director. Jesús Rodríguez always made me feel as a part of the team and would involve me in the corporate meetings taking place as part of my engineering training. In that sense, I have much to thank to my direct boss, Miguel Segarra, who was always very understanding with the fact that I had to attend to the assignments for the degree as well as the huge work load of the I3CON Project. Since I was always short of time, he gave me very good tips for improving my efficiency without giving up quality and he taught me to prioritize tasks and to analyze the problems well before rushing to solve them. Nevertheless, the best thing about working for Dragados was the good mood in the office: all the staff of the R&D department and the rest of the technical services would be always willing to help you: Nati, Carlos, Miguel, Elena, Arcediano, Carmen (both), Pilar, Tutor, Javi, Enrique, Manuel Javier, Manolo, Alberto... But it was my fellow trainees the ones who really made my stage there very pleasant; I have special fond memories of Víctor, Victoria and Marta.

The list of classmates with whom I have shared desk is profuse, but I would like to mention some of them. Firstly, my old friends Paco and Santi with whom I took my first steps in the engineering degree. On my return from my two-year gap to study architecture I made very good friends and the friendship has only strengthened since our trip to Canarias by means of preparing exams together: Carlos, Víctor, Alberto, Virginia, Jorge, Juanfran, Rafa... I thank them very much.

## Agradecimientos

Este Proyecto Fin de Carrera fue realizado durante dos años y medio de colaboración con el Departamento de Ingeniería de Sistemas y Automática, donde trabajé como investigador del “RoboticsLab”. Me gustaría expresar mi agradecimiento por la oportunidad que se me dio de participar en el Proyecto Europeo de I+D *Industrialised, Integrated, Intelligent Construction* (I3CON). Gran parte del éxito de este apasionante proyecto se debe al compromiso de la Universidad por aunar investigación académica y desarrollo industrial. Tengo que dar gracias a todo el “RoboticsLab” por su apoyo y en especial a Carlos Balaguer quien, aún siendo Vicerrector de Investigación, siempre tiene tiempo y palabras de ánimo. Y por supuesto, muchas gracias a mi tutor, Santiago Martínez de la Casa, quien siempre confió en mí y fue muy flexible en su tutelaje.

La mayoría del trabajo lo llevé a cabo en Dragados, bajo la Dirección de I+D. Jesús Rodríguez siempre me hizo sentir parte del equipo y me incluía en las reuniones que tenían lugar en la empresa como parte de mi formación como ingeniero. En ese sentido, tengo mucho que agradecer a mi jefe directo, Miguel Segarra, que fue siempre muy comprensivo con que yo tuviera que atender tanto mis obligaciones académicas como la ingente carga de trabajo del Proyecto I3CON. Como siempre estaba escaso de tiempo, me dio muy buenos consejos para ser más eficiente sin renunciar a la calidad y me enseñó a priorizar tareas y a analizar bien los problemas antes de lanzarme a resolverlos. Sin embargo, lo mejor de trabajar en Dragados era el buen ambiente en la oficina: todo el personal de I+D y del resto de servicios técnicos siempre estaban dispuestos a ayudarte: Nati, Carlos, Miguel, Elena, Arcediano, Carmen (ambas), Pilar, Tutor, Javi, Enrique, Manuel Javier, Manolo, Alberto... Pero fueron mis compañeros becarios los que de verdad hicieron de mi estancia algo entrañable; guardo un recuerdo muy especial de Víctor, Victoria y Marta.

La lista de compañeros con los que he compartido pupitre es profusa, pero me gustaría mencionar a algunos. Primero, mis viejos amigos Paco y Santi, con los que di mis primeros pasos en la carrera de ingeniería. Al regreso de mis dos años estudiando arquitectura hice muy buenos amigos y la amistad no ha hecho más que fortalecerse desde nuestro viaje a Canarias a base de preparar exámenes: Carlos, Víctor, Alberto, Virginia, Jorge, Juanfran, Rafa... muchas gracias a todos.

Since its creation, the UC3M has always stood out among other universities (both public and private ones) for its quality and modernity, epitomized by the bilingual programme that enabled me to learn the main subjects of the 4<sup>th</sup> and 5<sup>th</sup> course in English. In that group I came to meet first class students who proved to be even better friends: Pearson, María (Fernández e Izquierdo), Nacho, Talía, Antonio, Paloma, David, etc.

During all these years, my friends both from the primary and high schools have always been a breath of fresh air in the academic routine and I have shared with them great moments throughout summer camps, trips, football matches, and weekend nights out: David & Vane, Diego, Alfonso & Lorena, Ernesto, Fran & Susana, Alberto, Paula & Juan, María Hiniesto, Juan & Elena, Sancho, Roso... thanks.

The summer holidays in the village have also been part of my years in the university, although rather for how much I missed the place and its folks: Juanpa & Jorge, Luis & Paula, etc. I would also like to dedicate some words to all the amazing people I have met throughout my trips across Europe.

I opted for a long list of acknowledgments because one doesn't graduate every day, but I could have just written the following lines. Only thanks to the unconditional support of my family (grandparents Raúl & Ángela and Rogelio & Dolores, parents, uncles and aunts, cousins, brothers in law and sisters) I am about to becoming an engineer.

My father taught me since a child that working hard pays back. If there is something I will miss of the exams periods it is the long weekends we used to spend together afterwards doing some works at the village house. From my mother I have inherited the passion for reading and the tidiness. Both of them have taught me to work with great care and the most important lesson: to be honest with regards to the others and myself. My elder sister, María, has always been a reference for me; it was her who led me during my first years in the university, taught me to drive and instil in me the like for learning foreign languages and travelling abroad. My younger sibling, Esther, used to cheer me up with her monkeyshines and, moreover, would always be there willing to listen and looking after me as the good nurse she is. Finally, I would like to dedicate this project to grandpa Raúl, who has longed for this moment even more than me.

Raúl Sánchez Labrador

Desde su creación, la UC3M siempre ha destacado frente a otras universidades (tanto públicas como privadas) por su gran calidad y modernidad, ejemplificada por el programa bilingüe que me permitió cursar las asignaturas troncales de 4º y 5º en inglés. En ese grupo conocí a estudiantes de primera que demostraron ser aún mejores amigos: Pearson, María (Fernández e Izquierdo), Nacho, Talía, Antonio, Paloma, David, etc.

Durante todos estos años, mis amigos del colegio y del instituto han sido siempre un soplo de aire fresco en la rutina académica y he compartido con ellos grandes momentos a lo largo de campamentos, viajes, partidos de fútbol y noches de fin de semana: David y Vane, Diego, Alfonso y Lorena, Ernesto, Fran y Susana, Alberto, Paula y Juan, María Hiniesto, Juan y Elena, Sancho, Roso... gracias.

Los veranos en el pueblo también han sido parte de mis años universitarios, aunque más bien por lo mucho que eché de menos el lugar y su gente: Juanpa y Jorge, Luis y Paula, etc. También me gustaría dedicar unas palabras a toda la gente increíble que he conocido en mis viajes por Europa.

Me decanté por una lista larga de agradecimientos porque uno no se gradúa todos los días, pero bien podría haber escrito sólo las líneas a continuación. Sólo gracias al apoyo incondicional de mi familia (abuelos Raúl y Ángela, Rogelio y Dolores, padres, tíos y tías, primos y primas, cuñados y hermanas) estoy a punto de ser ingeniero.

Mi padre me enseñó desde pequeño que trabajar duro tiene recompensa. Si hay algo que echaré de menos de la época de exámenes son los fines de semana que solíamos pasar, una vez finalizados, trabajando en la casa del pueblo. De mi madre he heredado la pasión por la lectura y el orden. Ambos me han enseñado a hacer las cosas con esmero y la lección más importante: ser honesto para con los demás y conmigo mismo. Mi hermana mayor, María, ha sido siempre una referencia para mí; fue ella quien me guió durante mis primeros años en la universidad, me enseñó a conducir y me inculcó el gusto por aprender idiomas y viajar al extranjero. Mi hermana pequeña, Esther, solía animarme con sus monerías y además siempre ha estado ahí dispuesta a escucharme y cuidarme como la buena enfermera que es. Finalmente, me gustaría dedicar este proyecto a Abuelo Raúl, que ha esperado este momento incluso más que yo.

Raúl Sánchez Labrador



## Foreword

This Final Project (PFC) gathers the Research and Development (R&D) work carried out between March 2008 and September 2010 during my collaboration with the RoboticsLab belonging to the Department of Automatic and Systems Engineering (University Carlos III of Madrid) and the Service of R&D Projects in Building & Processes (R&D Directorate) of the construction company Dragados S.A. (ACS Group). The work was done within the framework of the European Project *Industrialised, Integrated, Intelligent Construction* (I3CON). As a collaborative R&D project, I3CON was part-funded by the European Union (EU) under Framework Programme 6 (FP6), NMP priority; commencing in October 2006, it was a 4-year project involving 26 partners from 14 countries across Europe. This project was led by Dragados (DRA), being the University Carlos III of Madrid (UC3M) one of the partners involved in the development of new concepts for components manufacturing and systems integration.

The main aim of the I3CON Project is enabling the transformation towards a sustainable European construction industry delivering industrially produced buildings, integrated processes and intelligent systems, making use of distributed control systems with embedded sensors, wireless connections, ambient / user interfaces and autonomous controllers. New business models, with highly specialised small- and medium-sized enterprises (SMEs) integrated in the supply chain, will deliver high performance spaces, smart services and lifecycle solutions to the buildings. The theoretical foundations over which this PFC unfolds can be found in the “deliverables” (confidential documents accessible on the I3CON Intranet –only for the Project Partners and the Commission Services). There are also published summaries, accessible for the members of the I3CON Community of Interest (CoI), and a series of newsletters and handbooks publicly available on the I3CON website ([www.i3con.org](http://www.i3con.org)).

This PFC goes deeper into the integration of intelligent systems within prefabricated building enclosure systems and structural components and their implementation in a mock-up prototype in which it is intended to test the constructability and compatibility of the systems. Also, it will be demonstrated the systems’ performance improvements by means of sensor networks and a series of monitoring & controlling strategies aimed at measuring consumptions and comfort parameters. Such Mock-up serves, therefore, as a test-bed prior to the application of the I3CON Project’s results in new residential buildings and rehabilitation works.

## Prefacio

Este Proyecto Fin de Carrera (PFC) recoge el trabajo de Investigación y Desarrollo (I+D) llevado a cabo entre Marzo de 2008 y Septiembre de 2010 durante mi colaboración con el RoboticsLab del Departamento de Ingeniería de Sistemas y Automática (Universidad Carlos III de Madrid) y el Servicio de Proyectos I+D en Edificación y Procesos (Dirección I+D+i) de la empresa constructora Dragados S.A. (Grupo ACS). El trabajo se hizo dentro del marco del Proyecto Europeo *Industrialised, Integrated, Intelligent Construction* (I3CON). Como proyecto colaborativo de I+D, I3CON fue co-financiado por la Unión Europea (EU) bajo el 6º Programa Marco (FP6), prioridad NMP; con comienzo en Octubre de 2006, fue un proyecto de 4 años con 26 socios de 14 países europeos. Este proyecto fue liderado por Dragados (DRA), siendo la Universidad Carlos III de Madrid (UC3M) uno de los socios implicados en el desarrollo de nuevos conceptos para la fabricación de componentes e integración de sistemas.

El fin último del Proyecto I3CON es facilitar la transformación de la construcción en Europa hacia una industria sostenible que produzca edificios de forma industrializada, procesos integrados y sistemas inteligentes, mediante sistemas de control distribuidos con sensores embebidos, conexiones inalámbricas, interfaces ambiente / usuario y controladores autónomos. Nuevos modelos de negocio, con pequeñas y medianas empresas (PYMEs) altamente especializadas en la cadena de suministro, dotarán a los edificios con espacios de alto rendimiento, servicios inteligentes y soluciones para el ciclo de vida. Las bases teóricas sobre las que se desarrolla este PFC están en los “entregables” (documentos confidenciales disponibles en la Intranet de I3CON –sólo para Socios del Proyecto y Servicios de la Comisión). Hay también resúmenes, publicados para los miembros de la Comunidad de Interés (CoI) de I3CON, y toda una serie de boletines y manuales para todo el público en el sitio web de I3CON ([www.i3con.org](http://www.i3con.org)).

Este PFC profundiza en la integración de sistemas inteligentes en componentes prefabricados estructurales y de cerramiento y su aplicación en un módulo prototipo en el que se pretende verificar la viabilidad constructiva y la compatibilidad de los sistemas. También se demostrarán las mejoras en el rendimiento mediante redes de sensores y una serie de estrategias de monitorización y control destinadas a medir consumos y parámetros de confort. Dicho Módulo sirve, por lo tanto, de banco de pruebas previo a la aplicación de los resultados del proyecto I3CON en edificios nuevos de viviendas y obras de rehabilitación.

The scope of this project goes beyond the mere design of systems and components, and applies methods for automating the off-site manufacturing processes and for making the on-site assembly more efficient. The ultimate aim is to take advantage of all this technology for developing new engineering and facilities management services throughout the whole buildings' life cycle, promoting new business models in the construction industry.

All the relevant information to this PFC (drawings, datasheets, bill of materials, etc.) can be found in the Appendixes, attached in electronic format. Most of the contents of this PFC were originally created for the I3CON Project, though not necessarily by the author; all the material provided by the I3CON partners, external collaborators and manufacturers is referenced throughout the text with the acronyms of the corresponding source in brackets. Given that I3CON was a collaborative project between different European partners, English is the language employed in the present work, but next it is included a summary both in English and Spanish.

El alcance de este proyecto va más allá del mero diseño de los sistemas y componentes, y aplica métodos para automatizar los procesos de fabricación en factoría y hacer más eficiente su instalación en obra. El fin último es aprovechar toda esta tecnología para desarrollar nuevos servicios de ingeniería y de gestión de edificios a lo largo de todo su ciclo de vida, promoviendo nuevos modelos de negocio en la industria de la construcción.

Toda la información relevante para este PFC (planos, hojas técnicas, lista de materiales, etc.) puede encontrarse en los Apéndices, adjuntos en formato electrónico. La mayoría del contenido de este PFC fue originalmente creado para el Proyecto I3CON, aunque no necesariamente por el autor; todo el material proporcionado por los socios de I3CON, colaboradores externos y fabricantes está referenciado a lo largo del texto con el acrónimo de la fuente correspondiente entre corchetes. Dado que I3CON era un proyecto de colaboración entre socios europeos, el idioma empleado en el presente trabajo es el inglés, pero a continuación se incluye un resumen en inglés y en castellano.

## Summary

In view of the difficulties with implementing the innovative components and systems conceived in the I3CON project on a dwelled building (because of their early stage of development), one of the main demonstration activities was building a Mock-up module to test the feasibility (in terms of physical integration and logical interoperability) of these components and systems, and evaluate their overall performance.

The design of all the systems involved in the Mock-up has the aim to develop new and more efficient solutions for the common issues in housing and, at the same time, to allow the evaluation of these systems. The values to be measured and monitored are: water (hot and cold), electricity and energy consumptions; temperature (ambient and surface) and relative humidity degree, both indoor and outdoor; presence; water temperature and flow; CO<sub>2</sub> concentration; and light level. This is done by means of a network of sensors, meters and actuators deployed throughout the Mock-up. The following components and systems have been developed by I3CON partners and are implemented in the Mock-up, namely:

- Façade panels, by Dragados (DRA).
- Electro-chromic windows, by Saint-Gobain Recherche (SGR).
- Under-floor radiant heating, Water saving system and Domestic fire extinguishing system, by Uponor (UPO).
- Multi-service trunking system, by the University of Loughborough (LOU).
- Wireless sensor network, by Thales Research & Technologies (TRT).

All these systems are controlled by the Building Operating System (BOS) developed by Lonix (LON). Besides, all that information handled by the BOS can be accessed through Mobile Productivity Tools developed by Intracom (ICOM) for carrying out operation and maintenance tasks.

Regarding the architectural design of the Mock-up, the innovative effort has been aimed to the development of new prefabricated façade solutions adapting current manufacturing processes, such as the “Sandwich Framex” typology, and the improvement in the thermal and acoustical behaviour of the Mock-up envelope with passive strategies, e.g. by using Phase Change Materials (PCMs) or vegetation.

The façade panels of the Mock-up were made up according to one of the following structural configurations, all of them making use of Glass-fibre Reinforced Concrete (GRC):

## Resumen

En vista de las dificultades para implementar los innovadores componentes y sistemas concebidos en el proyecto I3CON en una vivienda habitada (debido a su temprano estado de desarrollo), una de las actividades principales de demostración fue construir un Módulo prototipo para ensayar la viabilidad (en términos de integración física e interoperatividad lógica) de estos componentes y sistemas y evaluar su comportamiento global.

El diseño de todos los sistemas del Módulo tiene como objetivo desarrollar nuevas y más eficientes soluciones a problemas comunes en vivienda y, al mismo tiempo, permitir la evaluación de dichos sistemas. Los valores a medir y monitorizar son: consumos de agua (caliente y fría), electricidad y energía; temperatura (ambiente y superficial) y grado de humedad relativo, tanto interior como exterior; presencia; temperatura y flujo de agua; concentración de CO<sub>2</sub>; y nivel de luz. Esto se hace mediante una red de sensores, contadores y actuadores desplegados a lo largo del Módulo. Los siguientes componentes y sistemas han sido desarrollados por socios de I3CON e implementados en el Módulo, a saber:

- Paneles de fachada, por Dragados (DRA).
- Ventanas electro-crómicas, por Saint-Gobain Recherche (SGR).
- Calefacción por suelo radiante, Sistema de ahorro de agua y Sistema doméstico de extinción de incendios, por Uponor (UPO).
- Sistema de conductos multi-servicio, por la Universidad de Loughborough (LOU).
- Red de sensores inalámbricos, por Thales Research & Technologies (TRT).

Todos estos sistemas se controlan mediante el Sistema Operativo del Edificio (BOS) desarrollado por Lonix (LON). Además, a toda esa información manejada por el BOS puede accederse a través de las Herramientas de Productividad Móviles de Intracom (ICOM) para operación y mantenimiento.

Respecto al diseño arquitectónico del Módulo, el esfuerzo innovador se ha centrado en el desarrollo de nuevas soluciones de fachada prefabricada adaptando procesos de fabricación existentes, tales como la tipología “Sandwich Framex”, y en la mejora del comportamiento térmico y acústico de los cerramientos del Módulo mediante estrategias pasivas, e.g. usando Materiales de Cambio de Fase (PCMs) o vegetación.

Los paneles de fachada del Módulo se configuraron según alguna de las siguientes soluciones estructurales, todas ellas usando Hormigón Reforzado con fibra de Vidrio (GRC):

- **GRC Stud-frame:** GRC shell attached to a metallic frame. Two panels feature this solution, with a special plasterboard interior sheathing enhanced with PCM micro-capsules whose behaviour will be compared to that of a conventional one.
- **GRC Sandwich:** panel anchored to the main structure by means of cast-in channels and sliding bolt connections to accommodate the assembly tolerances. The innermost surface features a special pattern to improve the acoustical behaviour by diminishing the reverberation time. The outmost surface is covered with different kinds of light composite panels for aesthetics reasons.
- **Sandwich Framex:** it is an evolution which comprises “indoor sandwich + metallic frame + external elements”. One of the main advantages of the Sandwich Framex is the flexibility of the external cladding, which may consist of a great variety of elements configured in a modular way over a common sub-structure (the steel frame) and can be installed so that they can be easily disassembled for maintenance or upgrade. Different external elements have been selected in response both to bio-climatic concepts and architectural trends, among others: photo-voltaic cells, vegetated modules and a variety of composite/laminated panels. Two of the Mock-up façades which are configured with this solution include, besides, PCM packed in plastic boxes within the sandwich core, in order to improve thermal behaviour.
- **GRC Stud-frame:** cáscara de GRC unida a un bastidor metálico. Dos paneles se configuran con esta solución, con la particularidad de un trasdosado interior de yeso-cartón con micro-cápsulas de PCM cuyo comportamiento se comparará con el de uno convencional.
- **GRC Sándwich:** panel anclado a la estructura principal por medio de carriles embebidos y tornillería deslizante para acomodar las tolerancias de ensamblaje. La cara interior lleva un patrón especial para mejorar el comportamiento acústico disminuyendo el tiempo de reverberación. La cara exterior se termina con diferentes paneles ligeros de material compuesto por motivos estéticos.
- **Sándwich Framex:** es una evolución que consiste en “sándwich interno + bastidor metálico + elementos externos”. Una de las principales ventajas del Sándwich Framex es la flexibilidad para los acabados exteriores, que pueden consistir en un gran variedad de elementos modulares sobre una sub-estructura común (el bastidor metálico) y ser instalados de manera que sean fácilmente desmontables para mantenimiento o renovación. Se han seleccionado distintos elementos exteriores en respuesta a conceptos bio-climáticos y tendencias arquitectónicas, entre otros: células foto-voltaicas, módulos vegetados y varios paneles de material compuesto/laminados. Dos fachadas del Módulo con esta solución incluyen además PCM empaquetado en contenedores de plástico dentro del núcleo del sándwich para mejorar el comportamiento térmico.

For the sake of a better thermal efficiency, visual comfort (in terms of glare) and privacy, an Electro-Chromic Glazing Unit (ECGU) has been provided in one of the Mock-up rooms. The ECGU is fitted into a standard window frame allowing electrical power and control cabling. The ECGU makes possible certain degrees of shading that are controlled by the BOS according to solar irradiance, presence and indoor temperature, and operated in conjunction with the HVAC system thanks to the integration of all the systems within the BOS.

The Water Saving System consists in re-circulating the hot water only when it is needed. The system is connected to the sensor network in the building, and is activated whenever a person is within a predetermined area (kitchen or bathroom) or the water temperature inside the pipes is lower than a set value. Thanks to this solution, less water is wasted and there is less waiting time for hot water to be delivered.

En aras de una mejor eficiencia térmica, confort visual (deslumbramiento) y privacidad, se ha provisto una Unidad de Acristalamiento Electro-Crómico (ECGU) en uno de los recintos del Módulo. La ECGU se instala en una carpintería estándar que permita el cableado eléctrico y de control. La ECGU permite ciertos grados de oscurecimiento que se controlan por el BOS en función de la irradiación solar, presencia y temperatura interior, y se opera junto con el sistema de climatización gracias a la integración de todos los sistemas en el BOS.

El Sistema de Ahorro de Agua consiste en recircular el agua caliente sólo cuando es necesario. El sistema está conectado a la red de sensores del edificio y se activa cuando una persona está dentro de un área determinada (cocina o baño) o si el agua de las tuberías baja de una cierta temperatura. Gracias a esta solución se desperdicia menos agua y hay que esperar menos tiempo a que salga agua caliente.

The Domestic Fire Extinguisher System stands out for its simplicity: the water supply for the toilet cistern passes through the sprinklers. Thus, every time the toilet is flushed, confirmation is provided that there is no impediment for the water to flow (e.g. incrustations due to hard water) and therefore the system would work if a fire started. The Under-Floor Heating (UFH) system has been installed over the floor concrete slab. Its main virtue is its reduced installation height which makes it especially suitable for renovation works. The use of Cross-linked Polyethylene (PEX) pipes for these systems, installed using the “pipe-in-pipe” method, facilitates the renovation of the pipes given the case.

The Multi-Services Trunking System (MSTS) is a very innovative concept that comprises a set of runs for different kinds of media incorporated within a single vertical major artery and horizontal distribution nodes. The MSTS has been manufactured using rapid prototyping techniques, and a small portion has been installed in the Mock-up for proving the concept, delivering hot and cold water, air and electricity.

Concerning the monitoring and control of the Mock-up, the following inputs are studied:

- Consumptions measured with metering devices: Cold and hot water; Electricity.
- Parameters measured by the WSN: CO<sub>2</sub> concentration; Presence by means of Passive Infra-Red (PIR) technology; Relative Humidity (RH) degree; Light level; and Indoor ambient temperature. There is a gateway that converts the radio messages transmitted by the sensors into TCP/IP messages accessible from the BOS.
- Sensors deployed at different layers of the façade panels: Ambient and surface temperatures; Relative humidity degree. They are intended to assess the overall performance of the envelope system, with a focus on the effect of PCMs and vegetation.
- Parameters measured with wired sensors: Presence; Light level; Water temperature and flow in the pipes; and Ambient and surface temperature (indoor and outdoor).

Based on the information gathered by the sensor network, the BOS controls the Mock-up handling the following signals: Readings from the metering devices; Inputs from the sensors located in the kitchen, the bathroom and the test rooms; Data from the HVAC and UFH systems (controlled individually for each room to allow comparisons between them), the heat pump and the water pumps (for consumption simulation); Signals from the façade panels’ temperature and relative humidity degree sensors.

El Sistema Doméstico de Extinción de Incendios destaca por su simplicidad: el agua que va a la cisterna pasa a través de los rociadores. Así, cada vez que se tira de la cadena, se confirma que no hay ningún impedimento al flujo de agua (e.g. incrustaciones de cal) y por lo tanto el sistema funcionaría si se iniciase un incendio. La Calefacción por Suelo Radiante (UFH) se ha instalado sobre el forjado de hormigón. Su principal virtud es su reducida altura, que lo hace especialmente indicado para rehabilitaciones. El uso de tuberías de Polietileno Reticulado (PEX) para estos sistemas, empleando el método de “tubo-en-tubo”, facilita su renovación llegado el caso.

El Sistema de Conductos Multi-Servicio (MSTS) es un concepto muy innovador que consta de un conjunto de canalizaciones para distintos medios agrupados en una única arteria vertical y nodos de distribución horizontal. El MSTS se ha fabricado con técnicas de prototipado rápido y se ha instalado un pequeño segmento en el Módulo para demostrar el concepto, distribuyendo agua fría y caliente, aire y electricidad.

En cuanto a la monitorización y control del Módulo, se estudian las siguientes entradas:

- Consumos medidos con contadores: Agua fría y caliente; Energía eléctrica.
- Parámetros medidos por la WSN: CO<sub>2</sub>; Presencia con tecnología Pasiva Infra-Roja (PIR); Grado de Humedad Relativa (RH); Nivel de luz; y Temperatura ambiente interior. Hay una pasarela que convierte los mensajes de radio transmitidos por los sensores en mensajes TCP/IP accesibles desde el BOS.
- Sensores desplegados en las diferentes capas de las fachadas: Temperaturas ambiente y superficial; Grado de humedad relativa. Se pretende evaluar el comportamiento global del cerramiento, en especial el efecto de los PCMs y la vegetación.
- Parámetros medidos con sensores cableados: Presencia; Nivel de luz; Temperatura y flujo de agua en las tuberías; y Temperaturas ambiente y superficial (interior y exterior).

Basándose en la información recogida por la red de sensores, el BOS controla el Módulo manejando las siguientes señales: Lecturas de los aparatos contadores; Entradas de los sensores ubicados en cocina, baño y las habitaciones de ensayo; Datos de los sistemas de climatización y suelo radiante (controlados individualmente en cada habitación para poder hacer comparaciones), de la bomba de calor y las de agua (para simular consumos); Señales de temperatura y humedad relativa de los paneles de fachada.

Remote access to the Mock-up monitoring and control systems is very important for the measurement plans. Internet connection plays an important role for accessing the data and carrying out dwelling usage simulations. Furthermore, the application of Mobile Productivity Tools (MPTs), for example a Personal Digital Assistant (PDA) carried out by the maintenance staff, makes possible that any relevant information about the equipment installed in the building (i.e. the Mock-up), such as the assembly drawings, location in the building lay-out, and any data accessible from the BOS, will be available in real time for the operator working on site.

El acceso remoto a los sistemas de monitorización y control del Módulo es muy importante para el plan de medidas. La conexión a internet juega un papel fundamental para acceder a los datos y simular el uso de la vivienda. Además, la aplicación de Herramientas de Productividad Móviles (MPTs), por ejemplo una PDA que lleve el personal de mantenimiento, posibilita que información relevante acerca de los equipos instalados en el edificio (esto es, del Módulo), tales como dibujos de montaje, localización en el plano del edificio, y cualquier dato accesible desde el BOS, esté disponible en tiempo real para el operario trabajando en el sitio.

## List of Figures

Fig. 1-1: Conceptual Proposal for the I3CON Mock-up, June 2008 [DRA] .....	6
Fig. 1-2: Conceptual Proposal for the I3CON Mock-up, October 2008 [DRA].....	6
Fig. 1-3: Virtual model of the Mock-up viewed from the southwest, May 2010 [DRA] .....	7
Fig. 1-4: Virtual model of the Mock-up viewed from the northeast, May 2010 [DRA] .....	7
Fig. 1-5: Costs of the piping system [UPO] .....	13
Fig. 1-6: Sustainability monitoring tool for the Mock-up demonstrator [D+P].....	17
Fig. 2-1: Mock-up Layout; kitchen, bathroom, and three test-rooms [DRA] .....	18
Fig. 2-2: Mock-up 3D model [DRA].....	19
Fig. 2-3: Walkable roof system [INT] .....	21
Fig. 2-4: Left, roof solution on the western side; right, roof solution on the eastern side [DRA] .....	21
Fig. 2-5: Left, parapets at the CEDER building roof coping [DRA-SEIS]; Right, profiled aluminium drip guard with flexible waterproofing layer [Alwitra] .....	22
Fig. 2-6: Stud-frame typology: metallic frames are jointed to the GRC shells by projecting a dollop of GRC with a spray gun over the smalls pin attached to the trusses. The frame stiffens the shell for better bearing horizontal loads such as wind [DRA].....	24
Fig. 2-7: Special attention has to be put in handling GRC panels to avoid breaking corners [DRA] .....	25
Fig. 2-8: Sandwich Framex façade panel concept [DRA].....	25
Fig. 2-9: Different external claddings configurable in a modular way [DRA].....	26
Fig. 2-10: Cast-in channels are easy-to-install, adjustable fixings. They can absorb three- dimensional loads. During production of the façade panel, either polystyrene bead filler or strip filler provides protection against ingress of concrete into the channel. [Halfen] / [DRA] .	27
Fig. 2-11: Drainage Cell [Atlantis].....	31
Fig. 2-12: Anchoring system [ABIO-SEIS].....	31
Fig. 2-13: Fretwork decorative laminates for P-09 cladding [DRA].....	33
Fig. 2-14: Surface temperature sensors at PCM-enhanced wallboards [DRA] .....	35
Fig. 2-15: Cross section of façades P-03 and P-09, showing the ambient and surface temperature sensors for measuring the effect of the PCMs packed in the core of the sandwich panels [ABIO].....	36
Fig. 2-16: Surface & ambient temperature and relative humidity sensors at vegetated façade panels P-04 (South) and P-08 (North) [ABIO].....	37
Fig. 2-17: Elevation showing the location of the different sensors to be deployed at the vegetated façade panels [DRA] .....	38
Fig. 2-18: Piping system [UPO] .....	40
Fig. 2-19: Sprinklers integrated in cold water system [UPO] .....	42
Fig. 2-20: Layout of the UFH system [DRA-UPO].....	43
Fig. 2-21: Detail of the collector manifold for the UFH system [UPO] .....	44



Fig. 2-22: Cross-section of the Electro-chromic glazing unit [SGR] .....	45
Fig. 2-23: Dimensions of the ECGU [SGR].....	45
Fig. 2-24: Front view of the Electro-chromic glazing plate [SGR].....	46
Fig. 2-25: Luminous transmission of the glazing depending on the applied voltage. Luminous transmission measured in the equilibrium state for a given voltage [SGR].....	47
Fig. 2-26: Sketch of the hole to be drilled on the metalwork to allow the cables passing through: view of the bottom metallic frame [SGR] .....	47
Fig. 2-27: Cross-section of a conventional glazing frame with simple glass as inner and outer pane [SGR].....	47
Fig. 2-28: 100x75mm automation power supply box [SGR] .....	48
Fig. 2-29: Detail of the ECGU connector. There are 5 pins to control the power supply: two for the DC voltage (12 V) and three for the switch bit [SGR] .....	49
Fig. 2-30: Schematic representation of the control strategy [SGR] .....	49
Fig. 2-31: The MSTS, which is mounted in vertical position [LOU] .....	51
Fig. 2-32: MSTS in a corner of the portable cabinet and the required pre-installed service to allow the testing within the Mock-up [LOU].....	51
Fig. 2-33: Main dimensions of the MSTS [LOU].....	52
Fig. 3-1: Panel PC dimensions (in mm) [Afolux] .....	66
Fig. 3-2: Panel PC connections [Afolux].....	66
Fig. 3-3: Low voltage cable [TopCable] .....	66
Fig. 3-4: Lighting control system [DRA] .....	67
Fig. 3-5: Water meter installed in the Mock-up pipes [DRA] .....	68
Fig. 3-6: RTD sensor Pt-100 with pot seal [TC].....	71
Fig. 3-7: RTD sensor Pt-100 with self-adhesive patch [TC].....	71
Fig. 3-8: RH sensor probe installed at the vegetated panels. The transmitter is housed in a remote box, wall-mounted. Probes and wires of different lengths are available [TC / Deltaohm] .....	72
Fig. 3-9: Control wiring to RH sensor [LON] .....	73
Fig. 3-10: Schematic of the wiring connections [LON] .....	73
Fig. 3-11: Position of the wired, indoor temperature (T) and occupancy (O) sensors [LON] .....	74
Fig. 3-12: Flow switch [LON].....	75
Fig. 3-13: Resistance thermometers TEPAK Pt-1000 [Produal].....	76
Fig. 3-14: C&P Sensor front view [Hammond] .....	78
Fig. 3-15: C&P Sensor rear view [Hammond].....	78
Fig. 3-16: Left, an un-constructed housing unit for the CO <sub>2</sub> and Presence sensors; Right, once assembled and fitted [TRT] .....	79
Fig. 3-17: Left, Xbow enclosure for HLT sensors; Right, WSN Base Station [Xbow / TRT] .....	79
Fig. 3-18: Mobile Productivity Tools, Building Operating System, and Wireless Sensor Network server configuration with three different PCs [DRA] .....	82



Fig. 3-19: MPTs, BOS, and WSN with their respective software (developed respectively by ICOM, LON, and TRT) running on virtual machines over a single server PC [DRA] .....	83
Fig. 4-1: Transport of the Mock-up to its final location [DRA-SEIS] .....	89
Fig. 4-2: Mock-up south elevation [DRA-SEIS] .....	89
Fig. 4-3: Mock-up north elevation [DRA-SEIS].....	89
Fig. 4-4: Schematic of the integration of Uponor’s underfloor heating system within the structural floor slab [DRA].....	90
Fig. 4-5: Mock-up metallic structure and concrete floor slab [DRA-SEIS].....	91
Fig. 4-6: Details of the floor slab: mineral wool mortar and space for the installation of the UFH system [DRA-SEIS] .....	91
Fig. 4-7: HVAC equipment on the roof [DRA-SEIS].....	91
Fig. 4-8: Waterproofing membrane on the roof deck [DRA-SEIS].....	92
Fig. 4-9: Special moulds for conforming pyramidal shapes on panel P-10 [DRA-SEIS] .....	95
Fig. 4-10: PCM boxes and installation within the core of the sandwich panel by specialized factory staff, over the innermost GRC skin [DRA-SEIS] .....	95
Fig. 4-11: After the PCM boxes have been placed, GRC ribs are projected to stiffen the panel; over them, EPS foam is laid to provide thermal insulation [DRA-SEIS].....	96
Fig. 4-12: Left, schematic of the wooden laminates and the PV cells lay-out to be supported by the façade panel secondary structure (the metallic profiles of the Framex); Right, once installed over façade panel P-03 [DRA-SEIS].....	96
Fig. 4-13: Plants horizontally stocked for their better growing and align in front of façade P-08 prior to their installation [DRA-SEIS] .....	97
Fig. 4-14: Left, schematic of the vegetated cells lay-out and the Framex; Right, P-08 before completion: the underlying metallic profiles can be seen behind the green panels [DRA-SEIS] 98	98
Fig. 4-15: Supporting angles and installation over P-04 Framex [DRA-SEIS].....	98
Fig. 4-16: Vegetated panels after installation onto Framex façade [DRA-SEIS].....	99
Fig. 4-17: Details of the vegetated panels around the window opening [DRA-SEIS].....	99
Fig. 4-18: Schematic of the watering system [DRA] .....	100
Fig. 4-19: Left, irrigation system deployed on façade P-04; Right, drippers and water pipes, supported by the angled cleats that also bear the weight of the vegetated cells [DRA-SEIS] .	101
Fig. 4-20: Automation of the water tank filling by means of a level switch fitted inside the water tank beneath the vegetated façade panels [AKO / DRA-SEIS] .....	101
Fig. 4-21: Left, manufacturing process of the GRC sandwich panel with mineral wool filling; Right, special indoor finishing pattern for improving acoustical performance [DRA-SEIS] .....	102
Fig. 4-22: Left, façade P-06 featuring the sheet-metal panel before being clad with composite panels; Right, P-12 featuring different finishing sideboards [DRA-SEIS] .....	102
Fig. 4-23: Tee system [UPO] .....	104
Fig. 4-24: Manifold system [UPO] .....	104
Fig. 4-25: Primer coating (left) and plastic chambers (centre) laid onto the Mock-up floor for the Mini UFH system water pipes, installed by specialist staff (right) [DRA-SEIS].....	105

---

Fig. 4-26: UFH installation (left); all the circuits are collected in a manifold case (centre); water temperature and flow are controlled by the thermal drives (right) [DRA-SEIS] .....	105
Fig. 4-27: Left, detail of the ECGU spacer; Right, the connectors for power supply [SGR] .....	107
Fig. 4-28: Electro-chromic glazing unit. Dimensions and position of the power and control cables looking from the inside [SGR] .....	108
Fig. 4-29: Left, ECGU voltage (red) and ground (blue) connections; Right, cables hanging from the window sash, previously milled for that purpose [SGR] .....	108
Fig. 4-30: Left, ECGU power and control cables; Right, details of the cables to be connected to the pin connector of the control box [SGR] .....	108
Fig. 4-31: ECGU Control box with the pin connector (left side) and the voltage (red) and ground (blue) cables [SGR] .....	109
Fig. 4-32: Fan-coil units (left), pipes and controlling valves (centre) and water tank for DHW (right) [DRA-SEIS] .....	110
Fig. 4-33: MSTS fitted in the Mock-up kitchen: it can be seen the inlet and outlet runs, the water bypass and the operational sink [DRA] .....	111
Fig. 4-34: Visual detailing of the requirements for the testing of the MSTS in the Mock-up [LOU] .....	112
Fig. 4-35: Dimensions and positioning of the MSTS components in the Mock- up [LOU] .....	113
Fig. 4-36: C&P and HLT wireless sensors fitted in the Mock-up technical ceiling [DRA-SEIS] ..	114
Fig. 4-37: Relays and controlling modules with the cables pulled from the switchboard [DRA-SEIS] .....	115
Fig. 6-1: eKo Outdoor Weather Station [Xbow] .....	139

## List of Tables

Table 1-1: General objectives of this PFC; Description [RSL] .....	2
Table 2-1: Properties of the PCM (eutectic paraffin) packed in the core of sandwich panels P-03 and P-09 [ABIO] .....	29
Table 2-2: Vegetal species for the green façades [ABIO] .....	32
Table 2-3: Sensors to be deployed on the façade panels for monitoring their hygro-thermal performance [DRA] .....	34
Table 2-4: Hot water waste Vs. Distance [UPO] .....	40
Table 3-1: Summary of the sensors, metering devices and equipment used for M&C [DRA] ....	55
Table 3-2: M&C signals handled by the BOS and accessed by the MPTs [DRA-ICOM-LON] .....	57
Table 3-3: HW specs [DRA-ICOM-LON-TRT] .....	83
Table 3-4: SW specs [DRA-ICOM-LON-TRT] .....	84
Table 4-1: Mix for spray grade18 [DRA-SEIS] .....	93
Table 4-2: Recommended light levels [Adapted from EN 12464-1:2002] .....	106
Table 4-3: ECGU connection pins. Reference of the 5 pins connector: M12 Connector Binder 713 09-0433-387-05 [SGR] .....	107
Table 4-4: ECGU positions. Bit “1” means connected to ground, and bit “0” floated [SGR] ....	107
Table 4-5: Additional requirements for the WSN deployment [TRT] .....	114
Table 5-1: Scenarios for periodical measurements at summer time [DRA] .....	127
Table 5-2: Scenarios for periodical measurements at autumn time [DRA] .....	127
Table 5-3: Scenarios for periodical measurements; winter time [DRA] .....	128
Table 5-4: Summer time measurements schedule (June-July-August-September 2011) [DRA] .....	128
Table 5-5: Autumn time measurements schedule (October-November 2011) [DRA] .....	129
Table 5-6: Winter time measurements schedule (January-February 2012) [DRA] .....	129
Table 6-1: General objectives of this PFC; Assessment [RSL] .....	130
Table 6-2: Facade System overview [DRA] .....	132
Table 6-3: Electrochromic Glazing overview [DRA] .....	132
Table 6-4: Water Saving System overview [DRA] .....	133
Table 6-5: Multi-Services Trunking System overview [DRA] .....	134
Table 6-6: Building Control System overview [DRA] .....	134
Table 6-7: Sensor Network overview [DRA] .....	135
Table 6-8: Mobile User Interface overview [DRA] .....	136
Table 6-9: Structural configuration, height (H), width (W), thickness (T) and weight (M) of the Mock-up façade panels [DRA-SEIS] .....	137

# 1 Introduction

---

This Final Project (*Proyecto Fin de Carrera*, PFC) gathers the work carried out in the framework of the R&D Project *Industrialised, Integrated, Intelligent Construction* (I3CON) [01], specifically within the demonstration activities which encompassed, among others, the design and construction of a Mock-up building to carry out a series of measurements aimed to evaluate the performance of different components and systems. These components and systems were developed in the I3CON Project by different partners, and the learning of such work is gathered in several documents which may serve as the starting point of this PFC [02], [03], [04], [05] & [06].

Therefore, the State of the Art (SotA) of this PFC is that of the I3CON Project. In this section, the general objectives of this PFC are stated. Next, it will be explained the demonstration activities of the I3CON Project which configure the core of this PFC (the motivations and the different tasks). Demonstration activities embody all the ideas which were handled throughout the I3CON research work: the virtual test-bed was a primary stage of the development process, which in principle should have further materialized into a new building and the refurbishment of an existing one. Nevertheless, those endeavours proved to be unfeasible within the scope of the project, since few of the components and systems were in a stage where they could be implemented in a real building (because of regulation issues). Therefore, it was decided to build a full-scale physical mock-up instead.

Following, the Mock-up Demonstrator is presented, analysing its mission in terms of the three key concepts of the I3CON Project: industrially produced components, integrated processes, and intelligent building systems. These concepts will enable new services and business models e.g. in the fields of energy management and remote maintenance.

Finally, the specific objectives of each one of the different components and systems integrated in the Mock-up are given following the specifications given by the I3CON Partners, namely: the enclosure systems (façade panels and roof), the under-floor radiant heating system, the piping and water saving system, the fire extinguishing system, the multi-services trunking system, the different solar energy systems, the electro-chromic glazing, the wireless sensor network and the associated sensors, the Mock-up control system and metering devices and the mobile productivity tools. For each one of these components and systems it is said *what* is intended to be demonstrated and *how*. Note that some of these objectives are fulfilled with the construction/assembly in itself whilst others need to be subjected to a measurements plan conceived *ad-hoc*.

## 1.1 General objectives of this PFC

The Final Project (PFC) is conceived in the studies plan of the Industrial Engineering degree as the first professional job of the student. Therefore, the first objective was to carry out this PFC in real working environment. This was a premise since the work was done within the framework of an industry-led project, reporting to the I3CON Coordinator (the R&D Directorate of the Spanish construction company Dragados S.A.).

That said, the general objectives of this PFC are defined in *Table 1-1* and will be reviewed in the section devoted to the conclusions (§ 6).

*Table 1-1: General objectives of this PFC; Description [RSL]*

Objective	Description
1) Application of new production concepts such as Mass Customization through the use of a Design For Manufacturing, Logistics and Assembly (DFMLA) approach, Computer-Aided Design/Manufacturing (CAD/CAM) tools and Off-Site Manufacturing (OSM).	<p>Tailoring of industrially produced components to the specific requirements of the project and the end users (involved in the design an early stage) making use of the DFMLA approach, CAD/CAM tools and OSM manufacturing.</p> <p>Perform a Whole Life Cycle Assessment (WLCA) to reach a compromise between all the requirements, bearing in mind the manufacturing processes, the logistics involved and the assembly/disassembly and sustainability issues.</p>
2) Fitting of I3CON Project demonstrations of physical prototypes (elements, components, systems) and manufacturing processes i.e. proven manufacturability.	<p>Development of new solutions for buildings enclosure in terms of smart materials, components and structural configurations, ensuring their feasibility in terms of manufacture, assembly and operation.</p> <p>Integration of pathways (pipes and cabling delivering building services) for a more efficient installation on-site and/or integration in pre-fabricated components.</p>
3) To maintain the level and (ideally) progress beyond the SotA in terms of Industrialisation, Integration, and Intelligence (“I3”).	<p>Design the Mock-up employing as much I3CON developments as possible, incorporation whatever innovation may contribute to go a step further in the achievement of the three “Is” of the project.</p>
<p>4.1) Coverage of building stakeholders’ requirements.</p> <p>4.2) Promote the involvement of SMEs and bring the gap between academic research and industrial development.</p> <p>4.3) Dissemination/impact degree of the R&amp;D results. Exploitation potential of the project results.</p> <p>4.4) SMART Validation.</p>	<p>Degree in which the problems of the different actors involved in the design, construction and use of buildings are addressed.</p> <p>Degree in which SMEs are integrated as partners and not mere subcontractors and/or suppliers. Strengthen the collaboration between the University and private companies.</p> <p>Degree of awareness and level of implementation in the real industry achieved. Incorporation of the results into the building processes / production line of construction companies (i.e. Dragados or any of its subsidiaries).</p> <p>The objectives/results must be Sustainable, Measurable, Achievable, Realistic and Tangible.</p>

## 1.2 I3CON R&D Project Demonstration Activities

### 1.2.1 Motivations

A demonstration implies the verification, by means of experimental evidence, of the theory. The principles which led I3CON Project postulate that the spaces where people live can be improved thanks to industrialised production of components, their implementation within intelligent systems through which new and better services may be offered, and their integration along the whole life-cycle of the building, following a holistic approach which takes into account all the stakeholders' interests.

Demonstrators are: "live construction projects innovating or applying an element of best practice that it is hoped will lead to a step-change in performance for the participating organisations [...] Demonstrations have proven to be an excellent vehicle for the capture and dissemination of best practice knowledge in the built environment sector." [07].

Demonstrators constitute an ideal game-field for RTD work. On their success depends that not only partners, but other avant-garde companies and early adopters manage to take advantage of the innovations achieved, helping this way to one of I3CON's objectives which is that its results spread among the majority of the industry, thus changing it. Nothing can be compared to the impact and dissemination that practice from real projects achieves when trying to implementing the learning from RTD programmes. Demonstrations are committed to illustrating improvements based on clear benchmarks and measurements through the appropriate performance indicators.

Some benefits that industrial partners may achieve by participating in demonstration activities are: more predictability on cost and time for future RTD projects; greater productivity thanks to innovations in processes; fewer defects thanks to collaborative design, resulting in higher customer satisfaction scores; and excellent way for company to highlight its performance, reinforcing brand-image.

Communication and net-working within members of the demonstration team is very important. Participants compromise to sharing knowledge with each other, using multi-directional information flow. This collaboration brings together like-minded individuals from across different companies and countries from whom much can be learned, so workers involved in the demonstration raise their profiles. Qualification and skills improvement that ensue from this will be of advantage for their employer companies.

### 1.2.2 Tasks

I3CON demonstration activities comprised: Virtual building demonstrator, Mock-up demonstrator and Real building demonstrator [08] & [09].

#### 1.2.2.1 Virtual building demonstrator (I3CON Task 8.2)

Development of 3D models and simulation of building environments demonstrating before-and after-effects of the innovations in terms of environment quality and energy costs. It was not limited to 3D CAD models of buildings, systems and components, but comprised also technical specifications, dynamic simulations (e.g. of energetic performance), etc. The level of detail was as close to a real implementation plan as possible. Validity of the virtual model is demonstrated via monitoring of the Mock-up and the real building. This task was led by the

University of Stuttgart<sup>1</sup> (UST) in conjunction with Fraunhofer's Institute for Industrial Engineering and Organization<sup>2</sup> (*Institut für Arbeitswirtschaft und Organisation –IAO*) [10].

### 1.2.2.2 Mock-up demonstrator (I3CON Task 8.3)

This task covers the general demonstration for those developments of I3CON that can be physically demonstrated but whose application in real buildings is not feasible in the scope of the project. Examples of these elements are building components and/or new services technologies and production method demonstrators (this previous task is assumed here) that would need thorough testing, certification and/or maintenance during the lifetime of the building. The Mock-up is based on a 3D module used as a container showcase of technologies and new approach to building services process. The demonstration-container 3D module (henceforth, the Mock-up) was manufactured in a factory of one of the Dragados' companies specialized in prefabricated construction. The Mock-up will cover a range as wide as possible of I3CON technologies demonstrations. The Mock-up serves as a test-bed where the new components and systems developed in the I3CON project may be tested and validated. This task was led by Dragados<sup>3</sup> (DRA) and the deliverables of this task are the basis of this project [11].

### 1.2.2.3 Real building demonstrator (I3CON Task 8.4)

This task consisted in the selection of a multi-housing building in the Municipality of Madrid to be used with people living inside. The purpose is to show a running implementation of the I3CON building system architecture, including the Wireless Sensor Network (WSN) infrastructure developed in the context of the project, deployed in a real environment and the automation and ambient user interfaces that can take advantage of the building information collected from WSN sensors and metering devices. Two apartments (28 m<sup>2</sup> and 2-bedrooms) were equipped with presence, CO<sub>2</sub>, humidity, temperature, and light sensors. A gateway is put in each apartment for WSN connectivity and transfers the data via wired infrastructure (e.g., Ethernet) to a server. From the server, the data is made available to any other application via REST-based web services (accessible via LAN or Internet). A platform for the displaying of environmental data is also provided. Given the nature of the open architecture adopted, any HTTP-compatible application (such as a web browser) is able to access the sensor data and display it. As a result of this, mobile productivity tools (MPTs) and methods can be used in this environment or, optionally, in the Mock-up of the previous task (note that in the Mock-up the integration between the different I3CON components is shown to a greater extent than in the real building). This task was led by the "Municipal Housing & Land Company of Madrid" (*Empresa Municipal de la Vivienda y Suelo – EMVS*) [12].

---

<sup>1</sup> [www.uni-stuttgart.de](http://www.uni-stuttgart.de)

<sup>2</sup> [www.iao.fraunhofer.de](http://www.iao.fraunhofer.de)

<sup>3</sup> Dragados is the flagship company of the ACS Group ([www.grupoacs.com](http://www.grupoacs.com)) in the construction industry, and it participates in all kinds of infrastructure projects across the world. Although the biggest percentage of its annual turnover is on account of civil works, its presence in the building sector is also notable and includes: non-residential buildings (i.e. commercial, healthcare, educational, administrative, cultural and sporting uses); residential buildings throughout Spanish principal cities and tourist destinations with increasing international presence; and refurbishment of unique buildings and renovation works. Dragados participates in numerous Spanish and European R&D projects through its R&D Directorate.



## 1.3 The Mock-up Demonstrator

According to manufacturing principles, prior to mass-production, a series of prototypes must be fabricated as the subsequent step after virtual modelling. It is done so in order to face all the eventualities that may arise, investigate their solution, try different alternatives and polish up the product. Testing is easier in a controlled environment and any possible harm to users is avoided. Note that R&D results are not commercial products that can be used directly in real environments, and the synchronization between a real building project and a R&D project is very difficult because of their different nature. For these reasons, it seemed adequate to build a prototype to show the achievements from I3CON technological work-packages. A three-dimensional module (3D) was conceived for all the different components and systems to be assembled together and test their performance as a whole.

Nowadays, the production of 3D modules, their features and uses are limited. On the other hand, the I3CON Mock-up incorporates new developments conceived to achieve higher performance spaces that can offer a modular and prefabricated alternative to traditional construction of dwellings and offices. Besides, the module is designed according to principles of easy transportation and on-site assembly that were exposed throughout I3CON WP4 deliverables [13], [14] & [15].

### 1.3.1 Presentation of the proposal

The appraisal encompasses comprehensively all the I3CON characteristics: smartness, sustainability (economical, social and ecological), energy efficiency, modularization, flexibility, industrialization potential and value to customer. In such a complex project, it is fundamental to manufacture a prototype version. Effort must be aimed to accomplish the greatest degree of integration, since each component and system is designed and produced by different partners. Concerning this, it was critical to share information within the collaborative network.

The prototype has been produced by Dragados in one of the factories belonging to SEIS<sup>4</sup> and it serves as proving ground for both new constructions and refurbishment of existing buildings. It is located in the yard of the factory, as can be seen on *Drawing AR-01*.

The following images show the evolution of the I3CON Mock-up concept: it consists of components and systems resulting from I3CON work-packages WP3, WP4 and WP6. In order to achieve full integration of all components and systems, special attention was paid to the interfaces between them.

---

<sup>4</sup> SEIS, previously known as Drace, is a Dragados' subsidiary company highly specialized in integral building solutions such as modular units, prefabricated elements made of GRC, and architectural concrete, apart from traditional constructions and turn-key corporate relocations. The Mock-up has been manufactured and assembled at a SEIS' factory located at Las Cabezas de San Juan (Seville, Spain); [www.seis6.com](http://www.seis6.com)



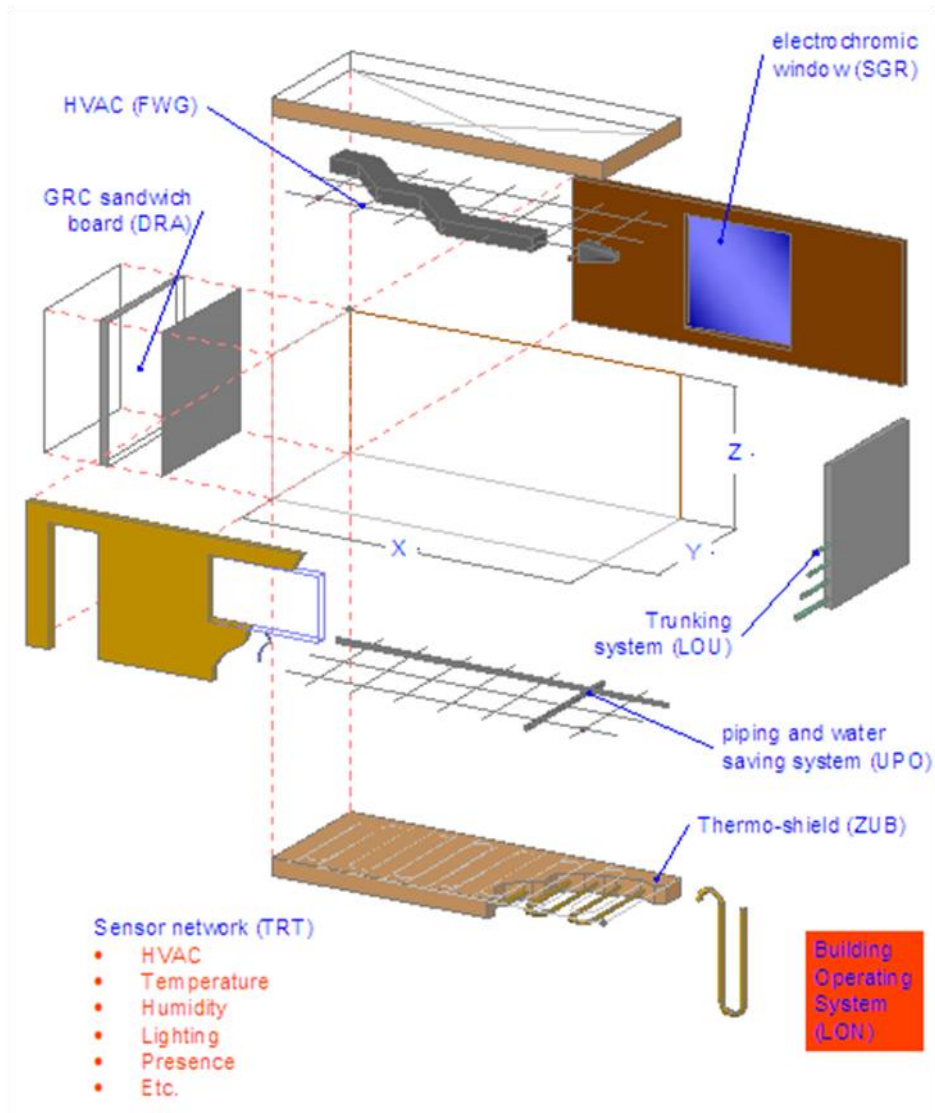

Fig. 1-1: Conceptual Proposal for the I3CON Mock-up, June 2008 [DRA]

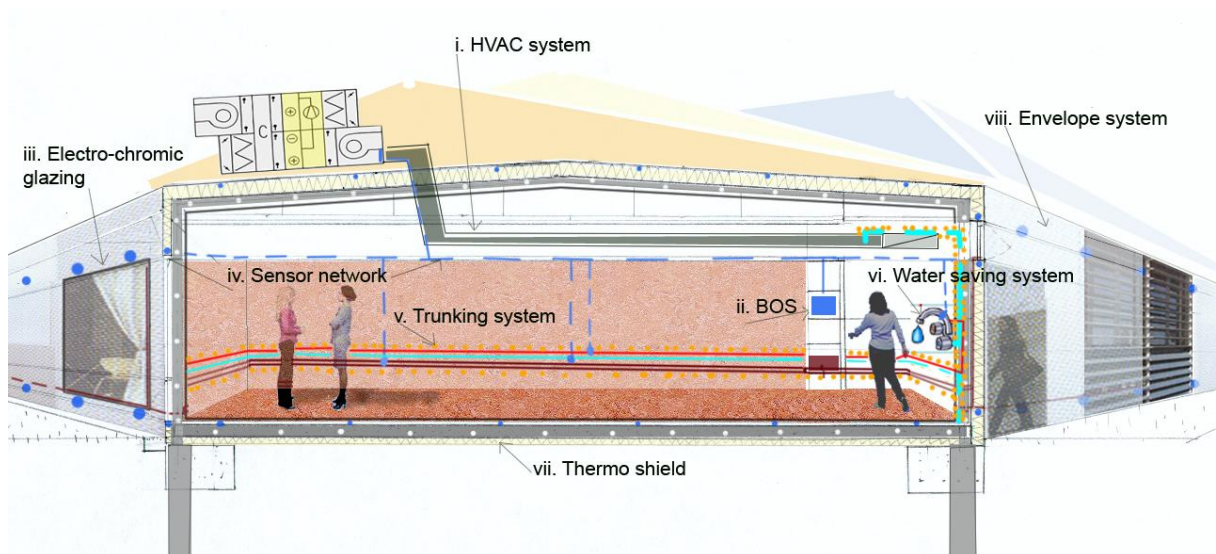
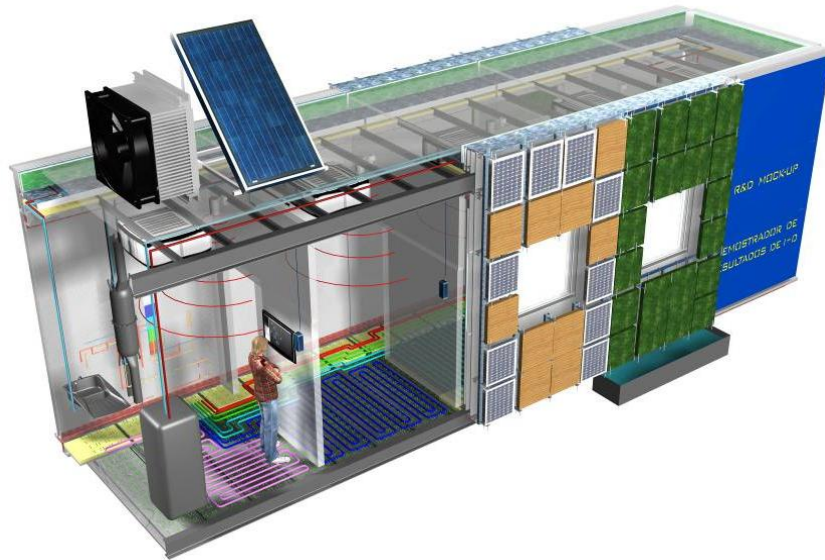
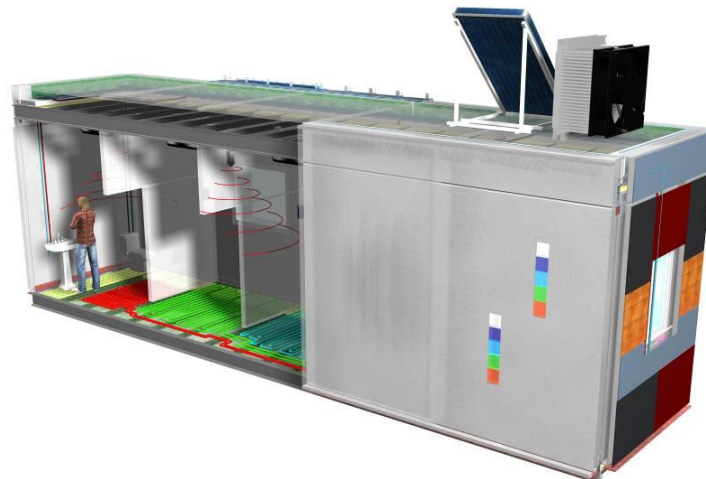

Fig. 1-2: Conceptual Proposal for the I3CON Mock-up, October 2008 [DRA]



*Fig. 1-3: Virtual model of the Mock-up viewed from the southwest, May 2010 [DRA]*



*Fig. 1-4: Virtual model of the Mock-up viewed from the northeast, May 2010 [DRA]*

### 1.3.2 The I3CON Mock-up Mission

The objective of the Mock-up, its “mission”, is not just to show prototypes of the different elements developed in I3CON, but also to demonstrate that the type of services envisaged in the project can be achieved with the support of the technologies deployed in the Mock-up. Each one of the three *I*s of I3CON is explained in the context of the Mock-up in the following sections<sup>5</sup>.

---

<sup>5</sup> The objective of the different I3CON components and building services systems is to support the business models and services envisaged in the project. This means that *Industrially produced, Integrated processes and Intelligent building systems* using distributed control systems with embedded sensors, wireless connections, ambient user interfaces and autonomous controllers will be used to deliver greater value to the stakeholders. New value-based business models with highly specialised SMEs working in radically contracted supply chains will deliver high performance spaces, smart business services and lifecycle solutions.

### 1.3.2.1 Industrially produced components

In the case of the Mock-up module, industrially produced components are used for the demonstrator:

- The module will be built through **off-site manufacturing** (OSM) at the factory, including installations, finishing, etc. If the module were to be part of a building (which is not the purpose of the demonstrator) a final assembly could be made on site.
- **Façade panels.** Different types of façade panels have been devised in order to test different alternatives to industrialised construction. Each of them tackles different problems (acoustical or thermal insulation, energy saving/generation, integration of industrialised components in the panels, etc.).
- **Electro-chromic glazing units.** These are components that are part of more complex components such as the façade panel. Further they are a form of actuator of the module control system.
- **Multi-services trunking system.** An industrially produced component to provide vertical runs of services and the interconnections (nodes) for their horizontal distribution at every storey of a building.
- **Water-saving and domestic fire-extinction systems.** Industrially produced systems that can be installed in prefabricated modules or bathrooms. These elements can also be installed in renovation of buildings due to their simplicity.
- **Auxiliary systems** such as the HVAC, the solar thermal collector and under-floor radiant heating are fitted in order to support some the I3CON developments.

### 1.3.2.2 Integrated Processes

Integration is a central theme that appears at several levels in the I3CON construction approach.

- **Process integration.** This relates to a global conception of the construction industry in which business concepts are mapped to supporting operational performance driven-processes over the lifetime of the construction. In the I3CON Mock-up process integration is demonstrated in the following aspects:
  - o A mock-up performance-based business model mapped to integrated processes, e.g. Energy management and Remote Maintenance business model.
  - o Integrated manufacturing and building operational processes supported by industrialised components. These are the ultimate processes that support the business models. In the module these are mapped to logical processes that will be carried out by the building operating and control system. For instance, these processes can be decomposed in tasks specifying how to achieve module comfort, how to reduce energy consumption, how to provide effective preventive maintenance, etc. according to a set of predefined performance metrics.
  - o Building operating system (BOS) which is made up from the integration of the I3CON components and that support the module processes.
  - o Mobile productivity tools (MPT). A maintenance company's point of view to the instruments that support a remote maintenance business model and that use the integrated processes offered by the Mock-up module.
- **System integration.** System integration means the existence of an integrated BOS, distributed control system and services supported by industrially manufactured smart components. Integration can consume a lot of resources in any development; in the case of

the Mock-up, integration is foreseen among the components that provide the services of the module.

- o System integration is achieved in I3CON by means of a standards-based Service Oriented Architecture (SOA) that allows querying data from a wireless sensor network. Other systems can be integrated into this architecture by means of the BOS and adapters to different protocols of common use in the building environment.
- **Component integration.** The components that make up the systems of the building are interoperable and are able to share resources towards a common goal (e.g. overall building comfort). Practical considerations for pathways integration and methods for ensuring pathways interoperability (in terms of integration within structural components, integration of systems in the building envelope, and physical integration of Building Control Systems) are given in [13], [14] & [15].
  - o In I3CON, the building systems architecture has been designed to be open but allows the integration of different legacy systems by means of wrappers or by means of the BOS. Therefore, there is a great flexibility for the design of system components and the way to integrate them into an I3CON system. For instance, web services based sensor querying LONWorks and MODBUS along with common Ethernet or TCP/IP are foreseen to coexist as integration media in the Mock-up module.
  - o Other form of integration is the physical integration among the components. In this regard, integration is considered at different levels. For instance, the integration of components into façade panels to improve specific characteristics (e.g. electrochromic glazing, vegetation, photovoltaic panels...), integration between the MSTs and the runs of the module for water, electricity and air distribution, etc.

### 1.3.2.3 Intelligent Building systems

In the context of the Mock-up, intelligence is defined as the ability to meet the performance metrics set-up for evaluation of the mock-up business model. Intelligence is an umbrella term that is used here to refer to the proper use of:

- Cross-system functionality and integration.
- Intelligent controller algorithms and controller-sensor communications.
- Integration of sensors in buildings.
- Service systems as parts of pre-manufactured building components

The above and other additional systems are used in order to profit according to some business model or to meet the demands of a service provided to some building stakeholder.

## 1.3.3 I3CON Mock-up Services and Business Models

There are two bogus<sup>6</sup> business models to be demonstrated in the mock-up demonstrator:

### 1.3.3.1 Energy management business model

Energy management business models aims at making use of the embedded intelligence in the Mock-up in order to procure a wise use of energy. This is achieved by means of:

- Local control of energy loads.
- Remote control of energy loads. The objective of this service is to help an energy provider with means to manage the demand of users, to analyse the energy consumption and to

---

<sup>6</sup> Since nobody is going to dwell the I3CON Mock-up, some consumption protocol/patterns are conceived in order to carry out the metering.



offer the best fares for the final users. This will result in lower energy utilization and, consequently, lower economic expense for the consumer.

- For the system to be implemented, different data must be captured from the Mock-up, such as:
  - o Recording of energy consumption:
  - o Total electricity consumption
  - o Main loads consumption recording: fridge, washing machine, dishwasher, oven, air conditioning, heating, etc.

### **1.3.3.2 Remote maintenance business model**

Let us take as example a service company that has made a deal with building owner that the temperatures inside the building must always be between 21 °C and 24 °C and CO<sub>2</sub> levels in the negotiation rooms must always be under 900 ppm. If the values are not within these limits it means lower prices of maintenance. The Service company has added several temperature and CO<sub>2</sub> sensors into the building and they have BACS based monitoring system and BSG.

One warm summer day the outside temperature is 30 °C and the inside temperature rises over 24 °C. This should not happen and the service man goes to check the situation. In the building, he touches with his tablet PC the RFID tag and gets access to building WLAN and BSG. From the tablet PC BSG client application, he chooses “performance history” and further “show rooms where values are too high or too low”. The BSG does not support CAD pictures (only ASCII information, XML-based information of spaces and related temperature values) but the service company BSG’s client has a graphical user interface and connection to CAD pictures for that purpose.

Next, the service-man goes first to the room where the temperature is too high. He does not find any problem and he chooses from the tablet PC BSG client the function “show information related to this room”. He gets a list from sensor values, room controller settings, some design values, room maintenance and performance history and link list of systems that effect to this space.

The service man chooses “air conditioning system” and gets link to the information related to the real time values and set points of the air handling unit (AHU), product data related to AHU, design values, the location of the AHU, list of its components, its effect area, maintenance and performance history as well as web link to AHU. He chooses “effect area” and finds out that all the rooms that have too high temperature are in that AHU area. Then he chooses “air handling performance history” and finds out that the values are acceptable until the last 2 hours. He changes the air flow from “set points” but without effect to temperature. He checks the “maintenance history” and finds out that the AHU was last served 4 years ago. Then he chooses “location of the AHU”. He goes to the room where the AHU is and chooses “monitor values”. He finds out that the temperature values are the same before and after the AHUs cooling coil. He chooses the “web link to AHU picture” and checks it. After that he checks “the cooling coil product data” and goes to buy the spare part and fix the problem. Finally he updates the cooling coil maintenance history.

## 1.4 Specific Mock-up objectives

### 1.4.1 Partners' specifications

In order to achieve full integration of all components and systems, it is the duty of each one of the producers and developers to indicate all the items their contribution will consist of. Detailed specifications are to be provided, **paying special attention to the connectivity with other components.**

Next epigraphs are completed by each one of the partners taking part in the design, production and management of the prototype module; all partners answered to the following questions:

- Demonstration scenario:
  - Virtual.
  - Mock-up.
  - Real building.
- Objectives and applications:
  - Explanation of the innovations.
  - Boundary conditions<sup>7</sup>.
  - Strategy for performance measuring.
- Material and material properties (physical and chemical).
- Dimensions and weight.
- Integration:
  - Physical connections.
  - Logical interfaces.
- Component production:
  - Manufacturing method.
  - Design variations.
- If they are commercial products:
  - Manufacturer.
  - Model.
  - Supplier.
  - Price.
  - Guarantees.
  - Delivery times.
- Installation:
  - Instructions.
  - Precautions.
  - Physical infrastructure.
  - Location.
  - Fixing method (glued, embedded, supported, screwed?).
  - Features: protections, casings, boxes, etc.
  - Requirements:
    - Electricity: mains or batteries, voltage, current, protections.

---

<sup>7</sup> E.g. Geothermoshield only makes sense for ZUB in combination with an inner (floor) heating circuit as a part of a pre-fabricated floor element (that could include piping, ducts etc.)

- Connectivity: network, cables, etc.
- Etc.

The following points present the objectives of each component/system, and how they are going to be achieved and measured.

### 1.4.2 Façade panels

- Objectives:
  - o Demonstrate modularity by incorporating new value-adding elements into the panel.
  - o Improve panel properties (e.g. heat storage capacity or acoustical insulation).
  - o Standardize installation of service runs in the panels.
- How:
  - o Modularity: Use outer façade panel structure (metal frame or trestles) to fix new elements to the façade panel, e.g. vegetated panels, PV panels, Mixed solutions, etc.
  - o Heat accumulation: Use of phase-change materials (PCMs) such as paraffin to improve heat storage, in several ways:
    - Micro-capsules embedded in plaster-boards, mixed with the gypsum.
    - Packages of PCM in bulk in the core of sandwich façade panels.
    - As aggregates of lightened non-structural concrete.
    - Future R&D project: mixed with GRC.
  - o Service runs: Use the pipe-in-pipe concept for services in sandwich panels (embedded in the insulation).
  - o Additionally:
    - Use of mechanical fasteners for ease of replacement (nuts and bolts).
    - Measurement of Hygro-thermal and acoustic comfort in a semi-quantitative way.

### 1.4.3 Roof

- Objectives:
  - o Improve space for service installations and headroom.
  - o Improve thermal and acoustic comfort.
  - o Ease of transportation.
- How:
  - o New roof structure without trusses to increase the available room space at the module's false ceiling. This is similar to the floor structure of the module.
  - o Polystyrene insulation in the roof structure.
  - o Ease of assembly / disassembly for transportation (mechanical fasteners).

### 1.4.4 Under-floor radiant heating

- Objectives:
  - o Test low height underfloor heating system to increase headroom.
  - o Improve module's floor thermal inertia.
- How:
  - o Use bow build height underfloor heating system (15 mm) on top of insulated floor.
  - o Use of phase-change material (PCM) on top of underfloor heating to accumulate heat. (finally discarded because the technical validation was controversial, see § 6.2).

### 1.4.5 Piping and Water saving system

- Objectives:
  - o Reduce costs.

- o Save water.
- o Easy installation.
- o Demonstration of open building systems architecture.
- How:
  - o Measure hot water consumption and compare to Uponor's statistics (this will be done with usage remote-controlled simulations).
  - o Pipe-in-pipe system<sup>8</sup>.
  - o Use of WSN independent presence sensor to be controlled by the Mock-up BOS, and use of wired strap-on temperature sensor for pump recirculation.

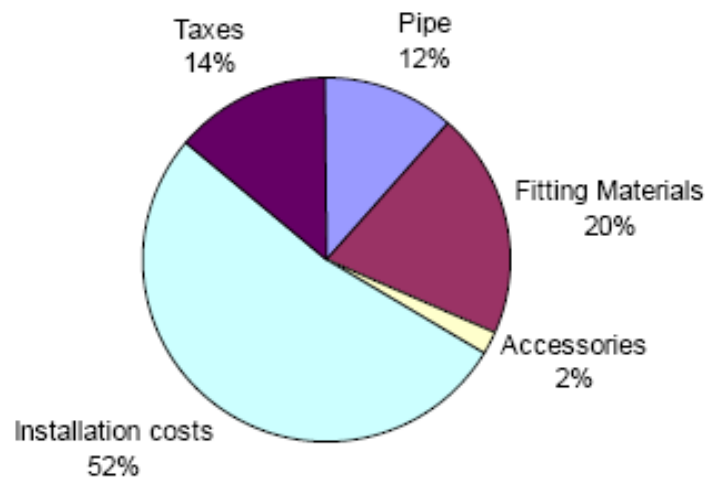

Fig. 1-5: Costs of the piping system [UPO]

#### 1.4.6 Fire extinguishing system

The "Residential Sprinkler" concept entails a simplified and cost-effective fire-protection sprinkler system focused primarily on saving lives and secondarily on saving property. Such prioritisation makes it possible to connect the residential sprinkler system to the building's cold water supply. This Sprinklers system provides cost-effective and reliable protection in case of fire in residential uses.

- Objectives:
  - o Demonstrate simplicity and low cost of the domestic fire extinction system.
  - o Ease of installation and low maintenance.
- How:
  - o System checked by WC flushing<sup>9</sup>.
  - o Installation using the pipe-in-pipe system.

#### 1.4.7 Multi-Services Trunking System

- Objectives:
  - o Proof of concept of an integrated vertical service run and horizontal distribution.
  - o Localised distribution of services (air, water and electricity).

---

<sup>8</sup> Installation represents the highest cost because of the labour time involved. The easier way to reduce installation cost is to make shorter the installation of fitting materials, taking advantage of the material pipe properties and the joining methods.

<sup>9</sup> With this, it is demonstrated how the system works, but not how well this system performs, because that would need a flow-metering device to check that no calcium carbonate particles due to hard water are getting embedded inside the pipe.



- o Show rapid prototyping manufacturing applications.
- o To demonstrate the potential of integrating all building services through the MSTs concept and to show the potential savings (time and cost) in installing the MSTs in comparison to conventional methods and to further run/show some experimental tests, such as longevity in a varied range of conditions –mainly temperatures and pressures– over long period if possible<sup>10</sup>.
- How:
  - o MSTs servicing hot and cold water, air ventilation (ceiling or under-floor) and electricity.
  - o Connection to ventilation distribution in a localised area.
  - o Connection to the standard piping system.
  - o A MSTs by-pass is included for safety reasons.
  - o LCD panel inside the module and video of MSTs run being manufactured.

## 1.4.8 Solar energy systems

### 1.4.8.1 Thermal collectors

- Objectives:
  - o Improve thermal comfort and contribute to energy saving by means of application of solar technology in conjunction with other systems. Emphasis to be put on the synergy of the systems, and not on the performance of the thermal collectors.
- How:
  - o Thermal collectors to be installed on the roof.
  - o Contribute to thermal comfort in collaboration with phase change materials (PCM) and under-floor radiant heating.
  - o Contribution to domestic hot water (DHW) in collaboration with water saving system.

### 1.4.8.2 PV panels

- Objectives:
  - o Viability of the integration of photovoltaic systems within the façade panels in response to “bioclimatic” market trends (the objective is not to measure the performance of the PV cells<sup>11</sup>, which are already a commercial product).
- How:
  - o PV panels will be attached to the metallic stud-frame of the façade panels both for electricity generation and innovative finishing.

## 1.4.9 Electro-chromic glazing

- Objectives:
  - o Suitability of active glazing units for the building sector.
  - o Integration in the building services architecture.
  - o Ease of installation in a standard frame.
  - o Thermal, acoustic, visual comfort (lab tests only).

---

<sup>10</sup> However, LOU did not explain how to measure this.

<sup>11</sup> During the conceptual design phase, it was taken into account the problem of less efficiency of PV panels when installed vertically, so it was considered to install them in the form of overhanging eaves which would act simultaneously as brise-soleils. Nevertheless, according to SEIS’ experts, this solution introduces a discontinuity in the roof, and damp stains may occur. The advantage would be a bigger annual yield thanks to the degree of exposure achieved by the inclination of the panel surface.

- How:
  - o Embedded in the facade panel and controlled by:
    - Control system and WSN by means of Luminosity sensor, Presence (occupancy) sensor and Temperature sensor
    - At user's will. Therefore, an independent manual controller of the glazing level may be installed.
  - o Integration in the metallic frame and façade panel (power and control wiring).
  - o Integration in the Mock-up (building) management system (i.e. the BOS).
  - o Control strategies for energy efficiency (heating and cooling thermal gains). Only semi-quantitative measurements.

#### 1.4.10 Wireless sensor network and associated sensors

- Objectives:
  - o Proof of concept of I3CON open building services architecture.
  - o Suitability of installation (e.g. retrofitting / renovation).
  - o Ease of maintenance.
- How:
  - o Accessibility to sensor network through an open web services interface.
  - o Access to network data from control system.
  - o Access to sensor network data from the mobile productivity tools.
  - o Panel PC application providing module comfort and energy efficiency data from WSN and other sensors and metering system measurements.
  - o Ease of installation.
  - o Remote battery status check and radio link check.

#### 1.4.11 Mock-up control system and metering devices

- Objectives:
  - o Demonstrate simple control strategies integrating different module systems.
  - o Proof of concept of building services architecture.
  - o Use of BIM information throughout the lifecycle.
- How:
  - o BOS providing BIM information data and access to WSN/wired sensors/metering devices data.
  - o Energy, water and electricity consumptions in the Mock-up. For this reason, it has to be decided if there will be start-up tests, remotely controlled simulations of use or both.
  - o Management of SGR electro-chromic glazing in combination with sensor data (luminance, presence and temperature).
  - o Management of water saving system and presence sensors.
  - o Etc.

#### 1.4.12 Mobile productivity tools

The purpose of the MPTs demo is to present the use of portable devices to display building's equipment information, user's indoor position and location of components and equipment in an area map.

- Objectives:
  - o Proof of concept of building services architecture.
  - o Demonstrate usefulness for maintenance services.
  - o Use of BIM information throughout the lifecycle.

- How:
  - Mobile productivity tools accessing:
    - WSN data through an open web services interface.
    - Building (module) information model from the BOS.
    - RFID and equipment location and positioning.
    - Downloadable CAD plans from PC server.

### 1.4.13 Objectives fulfilled with the construction in itself

#### 1.4.13.1 Floor

The suitability of Uponor's Mini underfloor radiant heating system for renovation and/or inner spaces where a technical floor is not wanted because there are height limitations, as is the case in 3D prefabricated modules is sufficiently demonstrated with the cross-section drawings and the photographs taken during the Mock-up construction. Leaving a zone of the floor, without tiling and levelling layer in order to see the small height of the underfloor heating system, is discarded.

#### 1.4.13.2 Roof

- Improved space for service installations.
- Thermal and acoustic insulation improvements achieved by innovative commercial products to be applied on the roof<sup>12</sup>. The objective is not to test the performance of these systems, but to show that they can be integrated architectonically in a prefabricated module.
- Ease of assembly / disassembly for transportation (mechanical fasteners). Demonstration in case of an eventual relocation of the module; the disassembly, transportation and new assembly of the module would be then recorded in video and timed.

#### 1.4.13.3 Fire extinction system

Its low maintenance and ease of installation is shown by the video of the installations fitting and by means of a transparent inlet box at the sprinklers.

#### 1.4.13.4 Multi-Services Trunking System

The concept of an integrated vertical service run and horizontal distribution is proved by the mere display of the MSTS inside its cabinet in the Mock-up. Viability of the rapid prototyping processes.

#### 1.4.13.5 Photovoltaic panels

The main objective is not to measure the performance of the PV cells<sup>13</sup> (feedback to design chapter), which are already a well-studied commercial product, but the viability and ease of their integration within the façade panels.

---

<sup>12</sup> E.g. waterproofing laminate incorporating PV cells like Evalon; [www.intemper.com](http://www.intemper.com)

<sup>13</sup> During the conceptual design phase, it was taken into account the problem of less efficiency of PV panels when installed vertically, so it was considered to install them in the form of overhanging eaves which would act simultaneously as *brise-soleils*. Nevertheless, according to Dragados experts, this solution introduces a discontinuity in the roof, and damp stains may occur. The advantage would be a bigger annual yield thanks to the degree of exposure achieved by the inclination of the panel surface. The PV panels will be attached to the metallic frame in a "smart" way. Dragados' Installations Service will recommend the appropriate manufacturer and model paying special attention to this feature.

### 1.4.13.6 Electro-Chromic Glazing Unit

Amenable to be installed in dwellings (standard frames, operable windows): the design of the metalwork in itself demonstrates this.

### 1.4.14 Sustainability

Fig. 1-6 shows the compliance of the mock-up demonstrator, illustrated in the Sustainability monitoring tool which was developed in I3CON WP1.

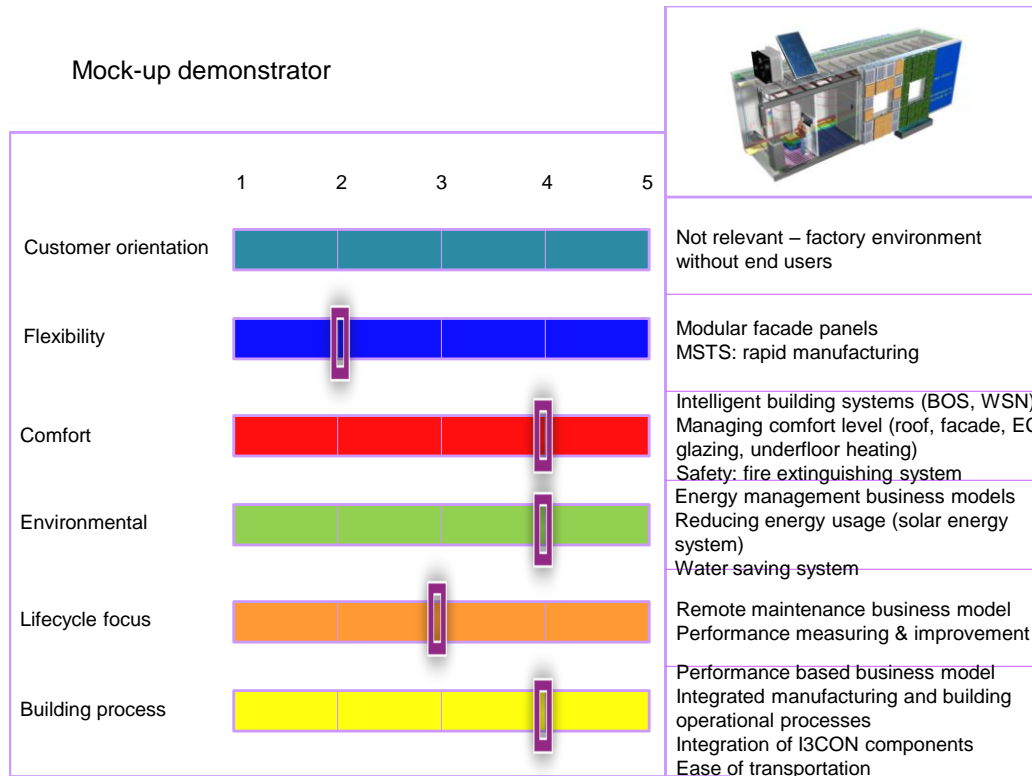

Fig. 1-6: Sustainability monitoring tool for the Mock-up demonstrator [D+P]

## 2 Design of the Mock-up components

The specifications and requirements of all components and systems are checked according to the main stages of the Mock-up lifecycle. Decision-making feeds back from the three of them<sup>14</sup>:

- **Design:** technical explanations and description of each one of the components and systems detailed in the drawings.
- **Construction:** includes manufacturing of the components, assembly of all them within the physical structure, installation of the equipment and implementation of the monitoring and control systems.
- **Use:** once the Mock-up becomes operational, it must be taken into account that nobody is going to live in it. For this reason, it must be established what is going to be measured for each system in order to test and validate the innovations, and how, in order to conceive:
  - o The auxiliary systems necessary for carrying out the measurements.
  - o The monitoring & control strategy.
  - o Start-up tests to be done on-site.
  - o Simulations according to patterns of use that can be remotely controlled (periodical measurements).

The usage of the module, the values amenable to be measured and monitored and the way the systems are to be controlled greatly influenced the design criteria of some aspects of the Mock-up. Therefore, since the design stage, it is taken into account the constructability and functionality of the module.

The Mock-up has one kitchen, three test-rooms (Local-1, Local-2 and Local-3) and a bathroom (*Drawing AR-02*), as can be seen on *Fig. 2-1* and *Fig. 2-2*.

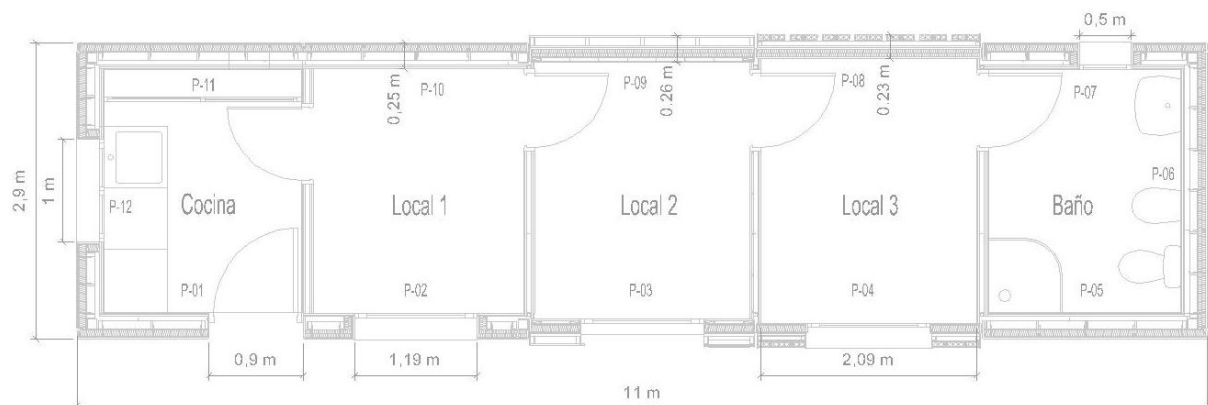

*Fig. 2-1: Mock-up Layout; kitchen, bathroom, and three test-rooms [DRA]*

<sup>14</sup> María García and Laura Manzanares (SEIS) were in charge of the architectural design of the Mock-up. Each partner (usually identified by its acronym in brackets) is responsible of the designs of their corresponding systems. Eduardo García and Manuel Domínguez (SEIS) were responsible, respectively, for manufacturing and quality management at the factory in Las Cabezas de San Juan (Seville, Spain). Carlos Bárcena (DRA) was the coordinator of the measurements plan. All the design changes, material supplies, manufacturing issues and measurement strategies were coordinated by the author of this project, Raúl Sánchez, and ultimately supervised by the industrial tutor Miguel J. Segarra (DRA).

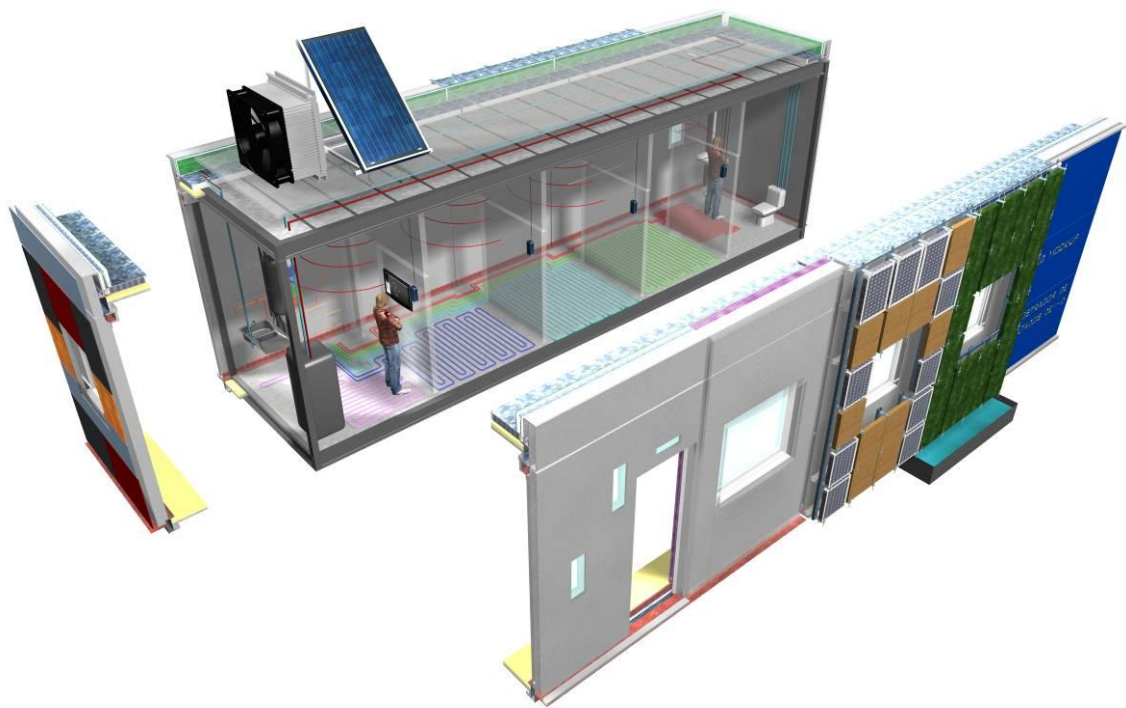

*Fig. 2-2: Mock-up 3D model [DRA]*

## 2.1 Structure

- The loads affecting the Mock-up structure are:
  - o Self-weight of the façade components, which acts downward parallel to the façade.
  - o Wind load (push and pull).
  - o Live loads (e.g. a person colliding with the inside of the façade –fall protection) and impacts, of special importance at ground floor.
  - o Stress loads caused by deflections of components through changes in temperature and humidity.
  - o Loads imposed by equipment installed on the roof (heat pump, solar collector, etc.).
- The Mock-up structure comprises (*Drawings AR-03 & AR-04 and ES-01 & ES-01*):
  - o Primary loadbearing structure: two concrete slabs (floor and ceiling) and a grid of vertical profiles that work as a torsion box.
    - The horizontal floor/ceiling slabs are made of concrete and are analyzed in § 2.1.1.
    - The vertical structure is made of metallic profiles with different sections depending on the stresses imposed by the different façade panel weights.
  - o Metallic diagonal studs are used for improving the stiffness of the module during its transportation. They are removed once it is located on the final site.
  - o The building enclosure is made of storey-high panels secured to the concrete slabs with the aid of different anchoring systems, depending on the façade typology (mounting shoes, angled cleats, cast-in channels with sliding bolt connections and/or metallic frames) to which the panels are connected.

### 2.1.1 Floor/Ceiling slab

- Floor slab composition:
  - o 45 mm concrete slab.
  - o 40 mm EPS (expanded polystyrene foam) for thermal insulation.
  - o 25mm mineral wool projected mortar [16].
  - o 5 mm self-levelling screed.
  - o 15 mm Uponor's under-floor radiant heating system (*see § 4.4*).
  - o Stoneware flooring.
  - o This renders, in theory, an overall heat transfer coefficient<sup>15</sup>  $U = 0.54 \text{ W/m}^2\cdot\text{K}$ . Nevertheless, this factor should be recalculated once the slab is finished to see the actual value.
- Note: Conventional SEIS' 3D prefabricated modules are usually covered by couple roofing (metallic covering over a steel trussed frame). Nevertheless, in order to gain space for service installations without surpassing transportation height limits, a prefabricated slab made of concrete poured over corrugated metallic sheets has been suggested for future modules.
  - o Pros:
    - The disappearance of the truss lattice allows higher spaces inside the module.
    - Better insulation against air-borne noise.
    - The slab can serve as the upper storey's floor.
  - o Cons: the subsequent load increment that this solution imposes requires either:
    - The addition of intermediate pillars, or
    - Using lightweight concrete<sup>16</sup>.

---

<sup>15</sup> The U-value describes how well a building element conducts heat. It measures the rate of heat transfer through a building element over a given area under standard conditions (usually 24 °C, 50% humidity and no wind). A smaller U-value is better for insulation purposes.



## 2.1.2 Roof covering

### 2.1.2.1 Roof deck / waterproofing

The Mock-up features a **flat roof** with two different solutions (*detailed in Drawing AR-18*):

- On the west zone, several equipment units (heat pump, thermal collector, deposit, etc.) are to be installed, therefore requiring a **walkable roof system**<sup>17</sup> for maintenance operations. All layers are positioned horizontally and parallel to the framework. It consists of three elements dry-installed (*Fig. 2-3*):
  - o Isolating drainage paving consisting of a slab of porous concrete over a base of extruded polystyrene foam (XPS) [17].
  - o Waterproofing membrane [18].
  - o Supplementary layer of puncture-resistant synthetic felt [19].
- The east zone only features the waterproofing layer over the synthetic felt. There is no equipment on it, so it doesn't need to be walkable.

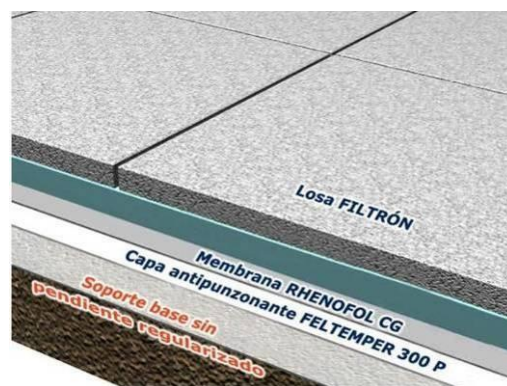

Fig. 2-3: Walkable roof system [INT]

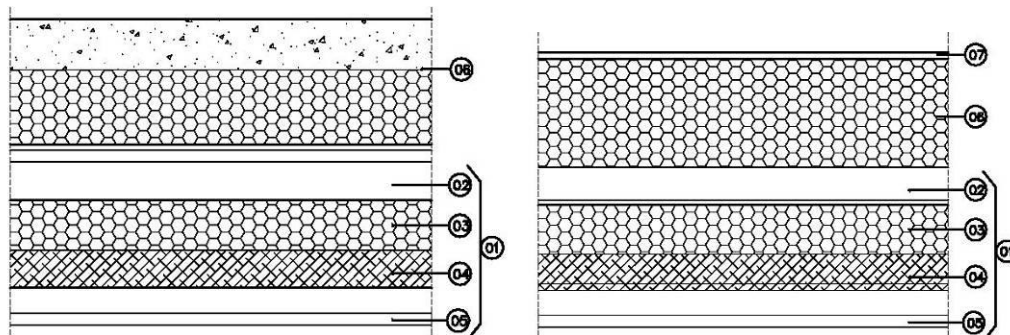

Fig. 2-4: Left, roof solution on the western side; right, roof solution on the eastern side [DRA]

### 2.1.2.2 Coping

- The transition between the façade and the roof is done with two different solutions (*Fig. 2-5*):
  - o Parapets made of the same material and finishing than the façade panels beneath.
  - o Coated aluminium frontages with a special profile and flashing to the roof sealing. These elements are easier to disassemble in case of an eventual transportation of the Mock-up.

<sup>16</sup> The concrete of the Mock-up ceiling slab was made with conventional aggregates, but manufacturing experiments afterwards using perlite (a type of expanded clay) resulted in a 20% reduction in weight (the precise formula is the subject of a patent application).

<sup>17</sup> Losa Filtrón + Rhenofol CG + Feltemper 300P.





*Fig. 2-5: Left, parapets at the CEDER building roof coping [DRA-SEIS]; Right, profiled aluminium drip guard with flexible waterproofing layer [Alwitra]*

## 2.2 Façade panels and partition walls

Dragados, as a result of the I3CON R&D work, introduced several innovations in the building envelope system, explained in the following chapters.

### 2.2.1 Façade design parameters

- **Materials:** The façades are mainly made of Glass-fibre Reinforced Concrete (GRC). The technical details of the prefabricated façade panels made with this material are specified in the “Technical Suitability Document” (*Documento de Idoneidad Técnica –DIT*) [20]. More possibilities have been studied:
  - o Sheet metal/composite panels.
  - o Concrete, although it was discarded for structural reasons (it is too heavy for the Mock-up lightweight structure)<sup>18</sup>.
- **Structure** of the GRC panels. There exist three main structural configurations:
  - o GRC Stud-frame: GRC shell attached to a tubular steel-frame (rectangular cross-section 80x40 mm, thickness 2 mm), mullioned with vertical trusses (rectangular cross-section 40x40 mm, eventually 80x40 mm, thickness 2 mm) spaced out 600-1200 mm (*Fig. 2-6*).
  - o GRC Sandwich panel anchored to the main structure by means of cast-in channels and sliding bolt connections (for tolerance re-adjustment).
  - o Innovative typology consisting of a GRC Sandwich with its smoother side –the “mould face,” i.e. the one in contact with the mould during the manufacturing process<sup>19</sup>– utterly finished facing indoors, and a metallic frame anchored both to the main structure with mounting shoes/angled cleats and/or to the GRC sandwich by means cast-in channels and sliding bolt connections. This frame gives support to any external element of the configurable façade. According to the GRC elements uses, the sandwich panel should not support all the façade structural loads [20]. Hence, the necessity of the metallic frame. From now on, this typology consisting of an “indoor sandwich + metallic frame + external elements” will be called Sandwich Framex (*see § 2.2.2*).
- The **anchoring** system (connections for transmitting the load) is based on two main solutions; the Sandwich Framex typology employs a combination of both:
  - o Angled profiles welded between the metallic frames and the main structure.
  - o Cast-in channels for sliding bolts and nuts in the sandwich panels.
- **Built-in conduits** (corrugated tubes) in the core of the sandwich panels, for housing electrical cabling and plumbing pipes (pipe-in-pipe system), intended for facilitating the renovation of installations.

---

<sup>18</sup> Concrete applied to façades is subject of TailorCrete, another NMP Project within the 7<sup>th</sup> Framework Programme, in which Dragados also participates. It is aimed to the production of industrialised unique concrete structures without the need for labour-intensive manual construction processes. TailorCrete will develop new industrialised processes and technologies including new formwork and reinforcement systems and materials as well as digital design and fabrication tools to radically change the way concrete is currently produced and used, thus playing a significant role in transforming the construction sector from a resource-based to a knowledge-based industry; [www.tailorcrete.com](http://www.tailorcrete.com). Also, Dragados proved the “Field Factory” concept in 2008 in the extension works of the “Ntra. Sra. del Recuerdo” School in Madrid. Concrete was casted in situ (making use of a configurable mold) and the panels were stocked up on-site until their elevation by cranes into position for their assembly.

<sup>19</sup> The other side is the “trowelled face”, since it is finished by means of a trowel during the manufacturing process. This side usually faces the indoor space and is sheathed with panelled gypsum plasterboards. With the Sandwich Framex configuration, those wallboards will not be necessary, thus saving materials and space.

- o Panels P-03 and P-04 incorporate them for electricity wires and cabling necessary to control the ECGU, running vertically from the technical ceiling to the window.
- o Plumbing pipes<sup>20</sup>.
- **Dimensions:**
  - o Height: the façade panels are one-storey high<sup>21</sup>.
  - o Width is recommended to be between 2 and 3 meters due to manufacturing and handling issues. In case of an eventual relocation of the Mock-up, façade panels have to be easily assembled and disassembled<sup>22</sup>.
    - Panels facing north and south are of the same width.
    - Eastern and western fronts are the maximum width allowed by transportation.
  - o Thickness: depending on the panel structural configuration and typology.
- **Weight:** GRC lightness may partially offset the significant weight increment consequence of the innovations introduced in this project (PCMs, vegetation, etc).
- **Manipulation:** special attention is put to the resistance of corners in order to bear transportation and handling without breaking<sup>23</sup> (Fig. 2-7).



*Fig. 2-6: Stud-frame typology: metallic frames are jointed to the GRC shells by projecting a dollop of GRC with a spray gun over the small pin attached to the trusses. The frame stiffens the shell for better bearing horizontal loads such as wind [DRA]*

---

<sup>20</sup> Though considered during the conceptual design phase, they were not be incorporated to the production process of the Mock-up sandwich panels because most conduits are fitted in the technical ceiling. Note that the only wall featuring vertical water runs is a sheet-metal panel (P-06).

<sup>21</sup> The maximum height of prefabricated modules is given by transportation limits.

<sup>22</sup> For example, to UPM Montegancedo Campus in Pozuelo de Alarcón, Madrid, or other locations in Extremadura (Spain). The Mock-up has been designed considering this possibility.

<sup>23</sup> Precisely to deal with this problem, it was necessary to redesign the detail of the overlapping of the sandwich panel over the slab in the “Sandwich Framex” configuration.



*Fig. 2-7: Special attention has to be put in handling GRC panels to avoid breaking corners [DRA]*

### 2.2.2 The Sandwich Framex concept

This innovative typology is based on the GRC Sandwich and Stud-frame solutions, which are both Dragados' patented systems [20]. The Sandwich Framex is an evolution which comprises "indoor sandwich + metallic frame + external elements" (Fig. 2-8).

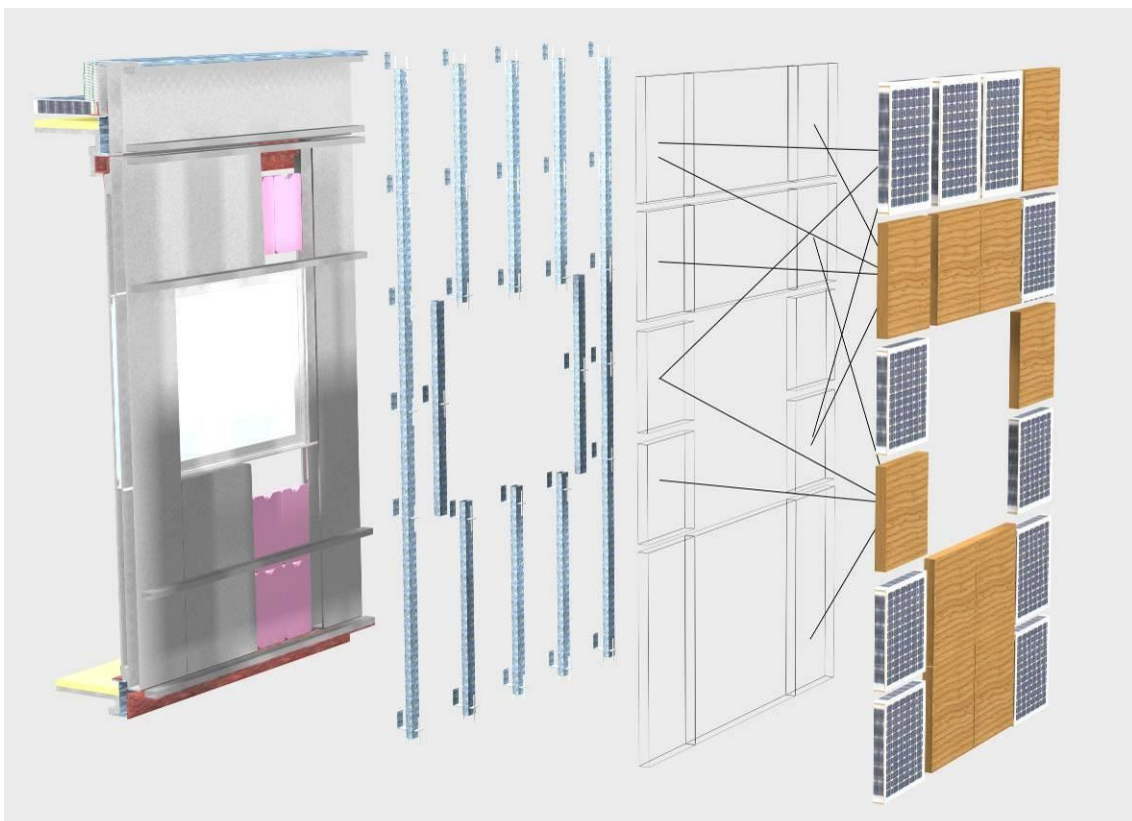
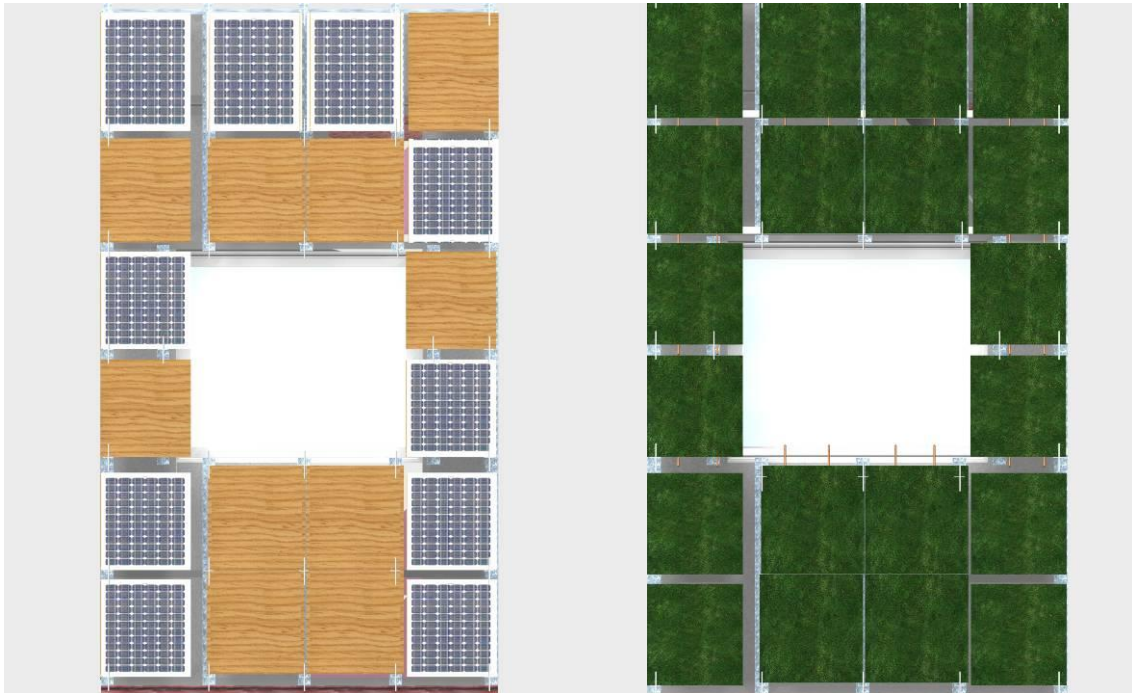

*Fig. 2-8: Sandwich Framex façade panel concept [DRA]*

- One of the main advantages of the Sandwich Framex is the flexibility of the external cladding, which may consist of a great variety of elements configured in a modular way over a common sub-structure (the steel frame), and installed so that they can be easily changed for maintenance, renovation or substitution.



- Examples of possible **external elements** have been selected in response to bioclimatic concepts and market trends, and include (*Fig. 2-9*):
  - o Photovoltaic modules.
  - o Vegetated cells.
  - o Composites and laminates.
  - o Metal sheets (profiled, curved, corrugated, micro-ribbed, perforated, etc.).
  - o Ventilated ceramics.
  - o Etc.



*Fig. 2-9: Different external claddings configurable in a modular way [DRA]*

- The **frame** comprises vertical trusses attached to the underlying sandwich panel, spaced out between 600 and 1200 mm. It is made of stainless steel<sup>24</sup> hollow structural sections (HSS) with rectangular cross-section (70x40 mm, thickness 2 mm). The profiles are attached to the sandwich by means of cast-in channels and sliding bolts connections as shown on *Fig. 2-10* [21].
- The load of the **sandwich** leans on the slab perimeter. It is important that the sandwich laps over the slab externally in order to ensure air tightness and waterproofing (transitions at basement and coping levels were redesigned).
- The load of the external elements is transmitted to the main structure through the steel stud framing structure, which is either welded to the I-beam at the perimeter of the floor slabs or attached to the sandwich panel, depending on the imposed loads.
  - o Mechanical fastening between the auxiliary frame and the primary structure was discarded because this way the panels might be less airtight due to the tolerances achievable in the factory, but different solutions have been studied for further developments [13].

<sup>24</sup> The steel is protected against corrosion by means of galvanizing.

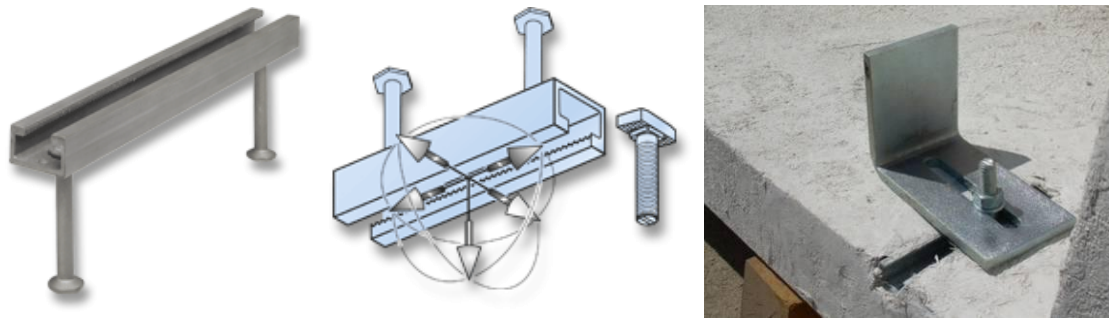

Fig. 2-10: Cast-in channels are easy-to-install, adjustable fixings. They can absorb three-dimensional loads. During production of the façade panel, either polystyrene bead filler or strip filler provides protection against ingress of concrete into the channel. [Halfen] / [DRA]

### 2.2.3 Façade panel typologies

The Mock-up envelope comprises 12 façade panels, which are numerated counter-clockwise (Drawings AR-02 & AR-09). Next they will be described one by one.

#### 2.2.3.1 General remarks

- Mock-up partition walls are conventional 15 mm drywalls [22].
  - Drywall is the term used for the construction of interior walls and ceilings using panels made of gypsum plaster pressed between two thick sheets of paper, then kiln dried. Plaster based interior finish techniques involved forcefully spreading a substrate of coarse plaster, known as the base (made up of the *scratch* coat and –optional– the *brown* coat) onto the wall before applying the smoother finish coat, each layer added in succession and all by hand. Since the drywall process requires less labour (it requires hand finishing only at the fasteners and joints and, besides, the screws are self-tapping), it has become the prevalent alternative for indoor finishing.
- Façade panels P-02, P-03, P-04 and P-11 are fenestrated with 1x1m windows. In principle, the panel P-02 is the one which features the electro-chromic glazing unit (ECGU), but the window fittings and metalwork are designed to allow its inter-changeability with P-03 and P-04 window panes.
- Façade panels P-02, P-03 and P-04 (facing south) are the same than the corresponding panels P-10, P-09 and P-08 (facing north), with the only difference of the window, in order to configure “slices” for qualitative measurements and comparison of the indoor conditions in the three different test-rooms.
- The external colour, texture and finishing of the different façade panels are due to aesthetics criteria and factory’s interests for widening its range of commercial solutions.
- There are metering devices, valves and other equipment necessary for the Mock-up operation (deployed on the inner side of P-11) and the Multi-Services Trunking System (MSTS, see § 2.7) anchored to the panel P-11.

#### 2.2.3.2 Note about Phase-Change Materials (PCMs)

- The heat flow in or out of a space depends on the thermal resistance and the temperature gradients between the room and its surroundings. Hence, a reduction in the temperature difference translates to a reduction of heat flow. When a substance changes e.g. from solid to fluid, it does so absorbing energy from the ambient. This energy is called latent heat because the temperature of the substance does not change during the process. In building science, the name Phase Change Material (PCM) is given to substances with a phase change temperature near the temperature of comfort at which indoor spaces are typically conditioned. Therefore the integration of PCMs within the building enclosure results in

small  $\Delta T$  between the walls and the interior air during the phase change of the PCMs. PCMs provide a thermal mass that absorbs/releases heat so the room does not continue to heat/cool up/down until all the PCM has liquefied/solidified, so the more quantity of PCM employed, the longer the buffering effect. The heat retained by the PCM is later returned to the ambient during the “discharge” part of the cycle.

- Since PCMs transform between solid-liquid in thermal cycling, encapsulation naturally become the obvious storage choice.
  - o Macro-encapsulation:
    - Early development of macro-encapsulation with large volume containment failed due to the poor thermal conductivity of most PCMs. PCMs tend to solidify at the edges of the containers preventing effective heat transfer.
    - The packaging material should conduct heat well; and it should be durable enough to withstand frequent changes in the storage material’s volume as phase changes occur. It should also restrict the passage of water through the walls, so the materials will not dry out; packaging must also resist leakage and corrosion. Common packaging materials showing chemical compatibility with room temperature PCMs include stainless steel, polypropylene and polyolefin.
  - o Micro-encapsulation allows the PCMs to be incorporated into construction materials, such as concrete and gypsum. Micro-encapsulated PCMs also provide a portable heat storage system.
  - o Molecular-encapsulation is another technology that allows a very high concentration of PCM within a polymer compound, drilling and cutting through the material without any PCM leakage [23].
- Toxicity/flammability: the use of wax-based PCMs is currently still restricted due to fire protection issues [24].

#### P-01 Conventional GRC Stud-frame panel

- This panel is fenestrated with the entrance door and inserts of translucent coloured glass blocks for improving natural daylight (flushed with the outer surface) [25].

#### P-02 GRC Stud-frame with special-shaped shell, Electro-chromic window and PCM-enhanced plasterboard

- The basic configuration of this façade panel is shown on *Drawing AR-10*, but the GRC shell is shaped as a truncated pyramid in order to try new (customized) forms with slight changes in present manufacturing methods.
- The window fittings consist of extruded aluminium sections for the frame and the sash. The metalwork is milled prior to assembly to allow power and control cabling. The awning sash<sup>25</sup> is inter-changeable between the windows of the rooms Local-1, Local-2 and Local-3 (*Drawing AR-17*).
- The indoor sheeting of façade panels P-02 and P-10 is made with **PCM-enhanced gypsum boards**<sup>26</sup> [26].
  - o PCMs are incorporated in the form of micro-capsules mixed within the gypsum [27].

---

<sup>25</sup> The window is operable around the lowest axis (the sash tilt inwards).

<sup>26</sup> Although supply and marketing of this product stopped in September 2009, Dragados had already used them in the construction of multi-housing flats in Cerdanyola del Vallès (Barcelona) and some samples were obtained through collaboration with the Technical University of Athens.



- o This drywall will be later replaced by conventional plasterboard in order to compare their thermal performance.
- o **Note:** the manufacture of plasterboard prototypes improving thermal and mechanical properties is subjected to future collaboration between Dragados and ABIO<sup>27</sup> and out of the scope of this Project.

### P-03 Sandwich Framex with PCM boxes in its core and modular external elements

- See Drawing AR-11.
- **Sandwich panel.** Description of the layers according to the GRC casting process:
  - o 15 mm of GRC.
    - This side will be the smoothest one and facing an indoor space.
    - It is finished but for the painting (at customer's will –in this case, white colour).
    - The painting should be enough for making up the marks left by the presence of the PCM boxes behind.
  - o In order to achieve greater thermal inertia, the sandwich incorporates at its **core PCM in bulk**<sup>28</sup>, packed in plastic boxes. There are two possibilities of packaging:
    - One layer<sup>29</sup> of high-density polyethylene (HDPE) 280x480x35 mm boxes with round corners filled with eutectic paraffin).
    - Bigger packages for improved  $V_{PCM}/S_{BOX}$  ratio are difficult to be incorporated to the core of the sandwich panels because of structural/manufacturing reasons and consequences of an eventual leakage. Besides, it has been proved that PCMs perform better in small containers and there is also the problem of the static head.
  - o 80 mm of expanded polystyrene foam (EPS) for thermal insulation.
  - o 15 mm of GRC. This side (trowelled) is not as smooth as the one facing indoors.
  - o Embedded corrugated pipes for running through them installation cables.

Table 2-1: Properties of the PCM (eutectic paraffin) packed in the core of sandwich panels P-03 and P-09 [ABIO]

Magnitude	Units	Value
Density	kg/m <sup>3</sup> ; g/cc	1080-1100; 1.08-1.1
Phase-change Temperature	°C	23
Conductivity in solid state	W/(m·K)	0,580
Conductivity in liquid state	W/(m·K)	0,291
Specific heat in solid state	J/(kg·K)	1.756
Specific heat in liquid state	J/(kg·K)	836

- **Steel-frame:** made of HSS profiles (as explained in § 2.2.2).
- **External elements:**

<sup>27</sup> Research group in Bioclimatic Architecture (ETSAM-UPM); [www.abio-upm.org](http://www.abio-upm.org)

<sup>28</sup> Other options involving PCM micro-capsules were considered and kept for further research work in collaboration with ABIO, e.g. trials of mix proportions in order to improve thermal inertia while ensuring cohesion of the mixture:

- Sandwich core made of lightened non-structural concrete with PCM micro-capsules acting as aggregates.
- PCM micro-capsules mixed with the cement of the GRC to be projected on the mould resulting in the indoor surface of the sandwich.

<sup>29</sup> Due both to manufacturing (adherence between HDPE and GRC), and heat transfer reasons, it is better to deploy only one layer for the cycle of solidification/liquation of the PCM throughout the night/day.

- o Photovoltaic (PV) panels: 2x1 m commercial solution<sup>30</sup>.
- o Wooden-finished laminates<sup>31</sup> [27].

#### P-04 Sandwich Framex with external vegetated panels

- See Drawings AR-12, AR-14 & AR-15.
- **Sandwich panel:** conventional GRC Sandwich [20] with 80 mm of expanded polystyrene foam (EPS) for thermal insulation. Finished side facing indoors.
- **Steel-frame:** this frame is in principle the same one that at façade P-03 and any other Sandwich Framex panel, no matter what kind of external elements are going to be installed<sup>32</sup>.
- **External elements:** vegetated panels prototypes which are lighter and easier to be replaced than existing commercial ones. The main characteristics of the new solution are:
  - o Plastic cells, currently used for vertical and horizontal drainage [29], serve as the base (Fig. 2-11). This 475x265x52 mm, polypropylene (PP) hollow structure is later:
    - Filled with substrate for vegetation<sup>33</sup>.
    - Wrapped in a synthetic felt made of polyester fibre which serves for holding the substrate and keeping humidity at the desired level. The felt is perforated to introduce the proto-plants and accommodate them in their respective hollows.
    - The final dimensions are 489x273 mm, depth 56 mm<sup>34</sup>, representing an advantage in comparison to the usual 80 mm deep metallic cells (thus heavier).
  - o The new solution pays special attention to the reversibility of the anchoring for an eventual substitution of vegetated modules<sup>35</sup>. They hang/lean on small hooks/profiles from the auxiliary metal structure, which is bolted to the external frame (Fig. 2-12). Each anchoring element supports 6 Kg approx.

---

<sup>30</sup> PV panels in the Mock-up are not intended to yield electricity, but to prove their suitability to be incorporated to the Sandwich Framex façade panel typology. For this reason, no specific model is suggested; the only requirement is that the dimensions are those indicated.

<sup>31</sup> Laminates made of several layers of phenolic resin-impregnated Kraft paper as a base to a layer of melamine-impregnated solid colour or printed design paper and a translucent overlay containing melamine, all bonded under heat and pressure.

<sup>32</sup> Later on, horizontal ad-hoc profiles are mechanically fastened to the vertical trusses of the steel frame to support the external elements in question. In case these elements are very heavy, the structure can be reinforced by anchoring the frame to the main structure.

<sup>33</sup> Some samples were filled with a mixture of vermiculite, vermi-compost and hydro-gel, while others were filled with perlite, earthworm humus and hydroponic substrate.

<sup>34</sup> These dimensions are flexible, since the felt can be wrapped around different number of plastic cells. Moreover, they plastic cells might be cut to fit within the façade composition, fenestration and detailing.

<sup>35</sup> If the plants needed to be replaced (because they are dead, or new species are demanded) the worker would perform better the task if the module can be easily taken down, thus preventing labour risks.



Fig. 2-11: Drainage Cell [Atlantis]

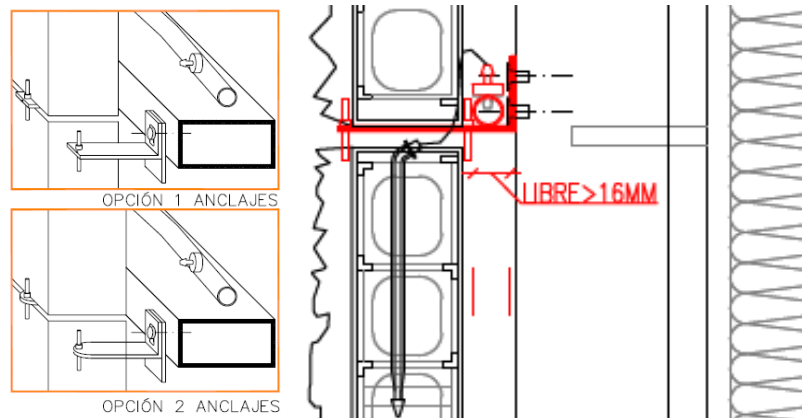

Fig. 2-12: Anchoring system [ABIO-SEIS]

- o A tank located below<sup>36</sup> the façade panel collects the water and re-circulates it by means of a programmable pump.
  - Although the design could have been improved to diminish evaporation, a conventional water tank is used to carry out water consumption measurements and compare them with typical vegetated façades.
- o The **vegetal species** (Table 2-2) are selected according to the orientation of the façade panels and the *Csa* conditions<sup>37</sup>, taking also into account maintenance issues and aesthetic considerations.
  - For the **south façade** (P-04) the most critical condition is solar irradiation in summer (more than water scarcity, since there is a watering system). For this reason, this prototype includes species such as *drosanthemum hispidum*<sup>38</sup>.
  - The main characteristic sought at the **north façade** (P-08) is the covering capacity, e.g. *hedera helix* of small leaves, which upholsters the façade panel in its totality despite being planted in separated modules. Besides, the cells employed as bases require root development to take place at 52 mm deep, and then ramify laterally.

<sup>36</sup> The water tank is not flushed with the ground level because the Mock-up stands on short concrete columns on a previously paved area. According to Francisco Ruiz (General Manager and Head of R&D projects at Intemper, [www.intemper.com](http://www.intemper.com)) this inconvenience may turn out to be an advantage because the water tank stands in the way between passers-by and the vegetal specimens, abating vandalism.

<sup>37</sup> Mediterranean climate, according to the Köppen classification. The Mock-up is located in Las Cabezas de San Juan (Seville, Spain).

<sup>38</sup> Plants in commercial vegetated panels are usually *Sedum* genus, which belong to the *Crassulaceae* family. These plants grow well under certain climate conditions such as water scarcity, but they are the heir of the first models marketed in Germany, where the solar irradiation degree is very different from Southern Europe, and therefore not the best choice for the Mock-up, given its location.

- Hanging plants, such as creeping rosemary, have been chosen rather than other species which would grow perpendicular to the panel.
- They are also selected for being not fruit-bearing, in order to ease grow and maintenance while saving water, although some of them could bear fruits such as the asparagus plant.

Table 2-2: Vegetal species for the green façades [ABIO]

Southern Façade P-04	Northern Façade P-08
<i>Lantana sellowiana</i>	<i>Vinca pervinca</i>
<i>Lampranthus</i>	<i>Hedera helix de hoja pequeña</i>
<i>Drosanthemum hispidum</i>	<i>Asparagus densiflorus "Myersii"</i>
<i>Rosmarinus officinalis postratus</i>	<i>Asparagus densiflorus "Sprengeri"</i>
<i>Lotus maculatus</i>	<i>Russelia equisetiformis</i>
<i>Plectranthus neochilus</i>	<i>Plectranthus ecklonii erma</i>
	<i>Plectranthus madagascariensis</i>
	<i>Grevillea lanigera Mt Thamboritha</i>

### P-05 GRC Sandwich with improved acoustical features

- The innermost GRC skin (the mould face) has a special finishing pattern in order to diminish the reverberation time.
- The core of the sandwich is filled with mineral wool batts [30].
  - o Fire resistance Euroclass A1 [31].
  - o Acoustic insulation (sample made of PYL15 + EM48/600-LM45 + PYL15)  $R_w = 44$  dB [32].
  - o Thermal conductivity  $\lambda = 0.037$  W/m·K [33].
- The outmost surface finishing (the trowelled face) is not acceptable from the aesthetics standpoint because of the casting process; hence, it is covered by:
  - o A composite panel consisting of aluminium cover sheets and a thermoplastic resins core nucleus (polythene) [34].
  - o The colour is Blue RAL5002, suiting Dragados-SEIS' corporate image with the inscription "R&D Mock-up".
  - o A yellow vinyl over a rigid foam sheet behind the external cladding [35].

### P-06 Sheet-metal Sandwich clad with metal composite panels

- Sheet-metal sandwich [36]:
  - o Composition:
    - 0.5 mm metallic skin
    - 40 mm core of polyurethane (PUR) in the form of low-density rigid foam, density 40 kg/m<sup>3</sup> –it could also have been made of mineral wool.
    - 0.5 mm metallic skin.
  - o Properties:
    - Fire resistance B-s3, d0 (sample with PUR core thickness t=30mm).
    - Acoustic insulation  $R_w$ : 25 dB.
    - Thermal conductivity  $\lambda = 0.022$  W/m·K.
- Cladding: same material than in P-05.
- Installation: either screwed over the underlying sandwich, or installed over profiles to configure a rear-ventilated façade.

### P-07 GRC Sandwich

- Similar to P-05. Fenestrated with a 0.5x1m window for natural ventilation of the bathroom.

### **P-08 Sandwich Framex with external vegetated panels**

- The same as façade panel P-04, but without window.
- The vegetal species change.

### **P-09 Sandwich Framex with PCM boxes in its core and modular external elements**

- Similar structural configuration than façade panel P-03, but without window.
- The external cladding elements are now the same kind of laminate panels than for P-03, but now they feature a decorative fretwork (*Fig. 2-13*).
  - o Note that the north orientation would make the installation of PV panels unworthy.

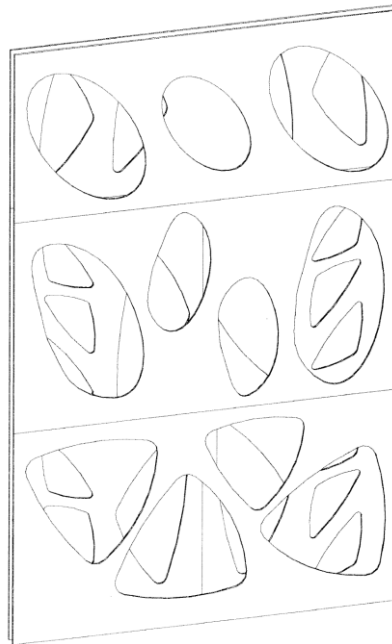

*Fig. 2-13: Fretwork decorative laminates for P-09 cladding [DRA]*

### **P-10 GRC Stud-frame with special-shaped shell, Electro-chromic window and PCM-enhanced plasterboard**

- The same as façade panel P-02, but without window, that is:
  - o Outmost surface featuring a quadrangular pyramidal form
  - o Innermost plasterboards with PCM-enhanced thermal storage capacity.

### **P-11 Conventional GRC Stud-frame panel**

- Same than P-01, but here the glass blocks are recessed<sup>39</sup>.

### **P-12 GRC Stud-frame panel**

- Fenestrated with a 1x1m window.
- The outer shell features a variety of medium-density fibre-cement cladding and siding boards [37] & [38], glued with appropriate adhesives.

---

<sup>39</sup> The glass blocks don't transmit light to the interior because they are covered by the gypsum wallboard over which all the pipes, valves and meters of the HVAC and plumbing systems are deployed.

- The transition between the façade and the roof is realized with a cap made of metal sheeting which covers all layers involved.

## 2.2.4 Façade panels performance

The Mock-up features different façade panels. Each typology tries to improve in some aspect considered of interest by the design team: energy savings by means of thermal storage in PCMs, improved thermal insulation, better reverberation time, etc. For each structural configuration, different measurements are taken at the external elements, the core of the wall and/or the indoor sheeting. In order to monitor the panels, it is needed the following:

- **Auxiliary equipment:**
  - o Clock-calendar integrated in the BOS software, data collection and access for data processing (see § 3.5).
  - o Energy meter for the fan-coil unit (FCU) installed at that room (see § 3.2.4).
  - o Indoor ambient temperature sensors (there are two per room, one wired and the other one part of the WSN, see §§ 3.3.3 & 3.4.2).
  - o Outdoor ambient temperature, solar radiation and relative humidity degree.
    - See also the discussion about the outdoor weather station (OWS), § 6.2.3.
- Next, it is stated the different sensors that are deployed for each measurement in order to monitor the façade panels' behaviour (summary in Table 2-3).
  - o There are ambient temperature (AT), surface temperature (ST) and relative humidity (RH) sensors, described in detail in § 3.3.1.
  - o As far as possible, the models of the sensors are the same for all the façade panels, in order to handle the same accuracy of data and to simplify the control system.
  - o There will be wires between the AT, ST, & RH sensors and the BOS, and cables for supplying the water pump (for watering the plants) with electricity. This must be foreseen in the design of the façade panels P-04 and P-08.

Table 2-3: Sensors to be deployed on the façade panels for monitoring their hygro-thermal performance [DRA]

Façades	PCM in plasterboard		PCM in sandwich core		Vegetated		Total Sensors
	S	N	S	N	S	N	
<b>Sensors</b>	<b>P-02</b>	<b>P-10</b>	<b>P-03</b>	<b>P-09</b>	<b>P-04</b>	<b>P-08</b>	
Ambient Temp	0	0	1	0	5	4	<b>10</b>
Surface Temp	2	2	3	3	7	7	<b>24</b>
Relative Humidity	0	0	0	0	2	2	<b>4</b>
<b>Total Sensors</b>	<b>2</b>	<b>2</b>	<b>4</b>	<b>3</b>	<b>14</b>	<b>13</b>	<b>38</b>

- **Plasterboards with PCM micro-capsules (P-02 & P-10)**

Fig. 2-14 shows the sensors deployed at the innermost side of the PCM-enhanced plasterboards of room Local-1. Left: southern wall fenestrated with a window (façade panel P-02); Right, northern wall, blind (façade panel P-10).

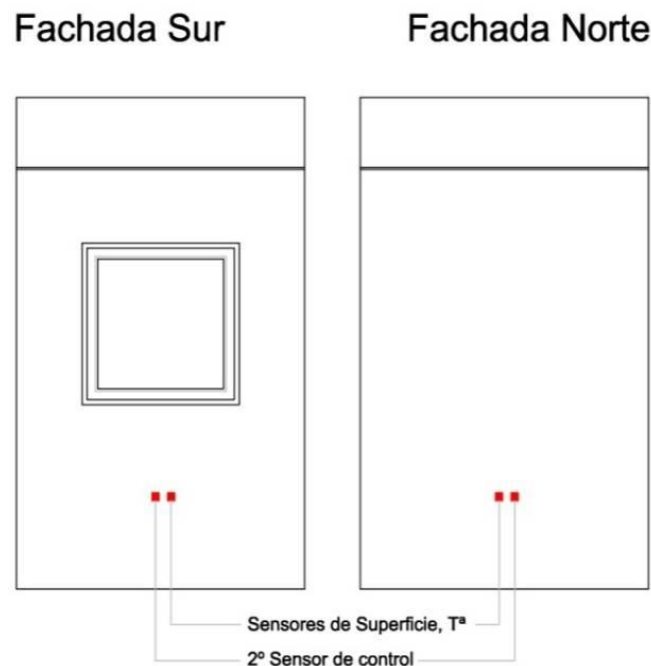

Fig. 2-14: Surface temperature sensors at PCM-enhanced wallboards [DRA]

- **PCM packed in plastic boxes, embedded in the sandwich panel core (P-03 & P-09)**
  - o Sensors deployment: *see Fig. 2-15.*
  - o 6 surface temperature sensors, 3 per façade panel.
    - Two of them are duplicated for data verification (“2º sensor de control”). These controlling sensors are necessary because they are neither physically accessible nor visible (they are behind the rear-ventilated laminated/PV panels).
  - o Location of the surface temperature sensors:
    - Same point at both sides (inner and outer) of the sandwich panel.
    - Medium height between the bottom edge and the window sill and at the centre of the panel width (same distance to the lateral edges).
    - The verification sensors will be close to them.
    - Note: if the PV panel was connected, the space behind it would overheat and these measurements would be distorted. In fact, the mere presence of a different external element may have effects. For this reasons, the sensors are located at the indicated height (same material –laminated panels– at south and north façade).
  - o 1 ambient temperature sensor located at the buffer space of the south façade.
  - o Note: Ideally, another temperature sensor should be located at the GRC ribs which hold the plastic containers for measuring the temperature of the PCM boxes themselves. Since it was not possible to do so<sup>40</sup>, a scale model of the façade panel with only one PCM box will serve (being the rest of materials, thickness, etc. the same). A temperature sensor is to be immersed through the cap of the plastic box and sealed afterwards so it can measure the temperature of the PCM itself. The cable goes out of the bottle in order to be connected to the control SW.
  - o Note: For the PCM being effective during the summer time, it is necessary to bring the PCM back to solid state at night. Therefore, it seems necessary to program the opening of the windows for natural ventilation at night-time.

<sup>40</sup> The final version of the measurements plan was released when the façade panels had already been manufactured. Therefore, this sensor is not going to be deployed (drilling the panel in order to insert it would not be advisable because of the risk of perforating the plastic boxes and subsequent leakage).



- Problem 1: refrigeration is hindered by the fact that the PCM boxes are not in direct contact with air.
- Problem 2: windows opening and closing are not automated operations but necessary for night ventilation. For this reason, they are meant to be opened manually at dusk during the summer measurements campaign by the factory staff.

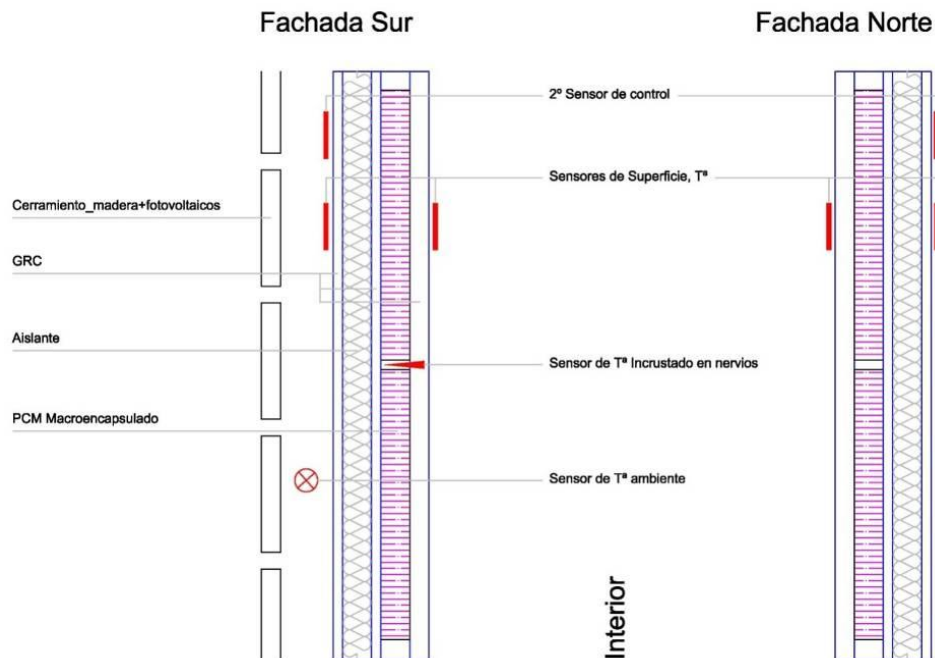

Fig. 2-15: Cross section of façades P-03 and P-09, showing the ambient and surface temperature sensors for measuring the effect of the PCMs packed in the core of the sandwich panels<sup>41</sup> [ABIO]

- **Vegetated panels (P-04 & P-08)**

- o The objective in the present project is to obtain the temperature gradients throughout the vegetated façade and the relative humidity degree in order to characterize the micro-climate created in the ventilated chamber between the external vegetated elements and the inner GRC sandwich panel and to calculate the evaporative cooling rate achieved. Hence, the only effects which are going to be measured in the Mock-up are those concerning hygro-thermal performance. With this objective, a set of sensors is located at different layers of the green panels.
- o The deployment of the sensors is shown on Fig. 2-16 and Fig. 2-17. The following quantities for each sensor include both south (P-04) and north (P-08) façades.
  - Sensors 1 (ST x 4 units) measure the surface temperature at the shadowed side of the vegetated cells (attached to the wrapping felt).
  - Sensors 2 (ST x 4 units) measure the surface temperature at the outmost skin of the GRC sandwich panel.
  - Sensors 3 (ST x 4 units) measure the surface temperature at the external side of the vegetated cells (attached to the wrapping felt).
  - Sensors 4 (ST x 2 units) measure the surface temperature at the innermost skin of the GRC sandwich panel.
  - Sensor 5 (AT x 1 unit) measures the indoor ambient temperature at the test room Local-3. The sensor is located on the inner surface of façade P-04<sup>42</sup>.

<sup>41</sup> Note that the temperature sensors embedded within the PCM package will be finally deployed in a small model of this façade manufactured with only PCM package for its testing under lab conditions.

- Sensor 6 (AT x 4 units) measures the ambient temperature at the ventilated chamber.
- Sensors 7 (AT x 4 units) measure the ambient in the vegetated zone. They are clipped to the leaves (depending on the vegetal specimens).
- Sensors 8 (RH x 4 units) measure the relative humidity degree at the ventilated chamber.

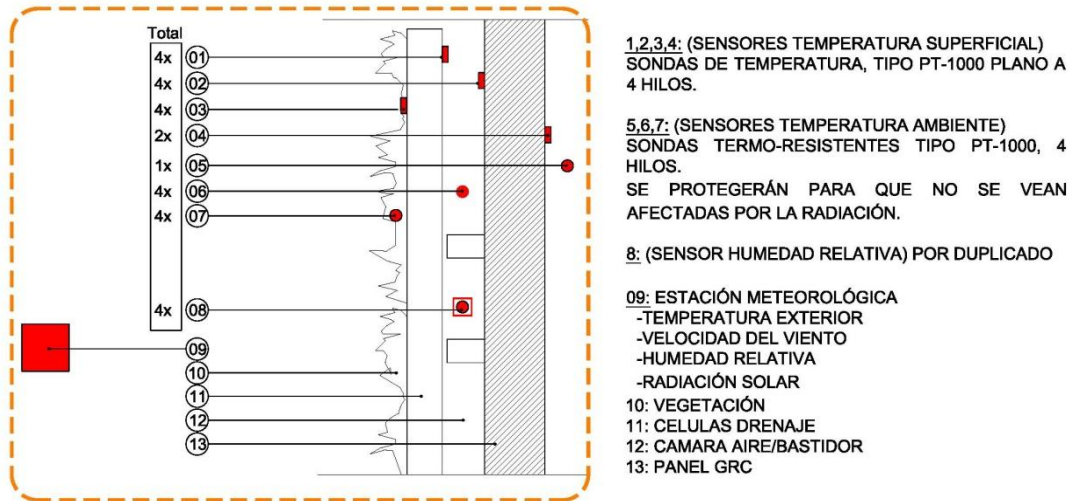

Fig. 2-16: Surface & ambient temperature and relative humidity sensors at vegetated façade panels P-04 (South) and P-08 (North) [ABIO]

- o The vegetated modules may also contribute to improve acoustic insulation and act as CO<sub>2</sub> sinks. Nevertheless, the effects on CO<sub>2</sub> concentration inside the Local-3 (that could be compared with the values in other rooms fitted with C&P sensors) might be negligible. In the outside, the vegetation contributes to fix CO<sub>2</sub>, but quantifying how much is not easy<sup>43</sup>.

<sup>42</sup>.It may be redundant with the indoor ambient temperature wired sensor and with the HLT wireless sensor deployed on the partition wall between the Local-3 and the bathroom, but it serves to complete the temperature gradients throughout the whole façade panels and would also serve to calibrate the sensors at the façade panels if there was any offset.

<sup>43</sup>.This is, in fact, matter of another R&D project between Intemper and the Department of Vegetal Biology and Ecology of the University of Seville (Spain).

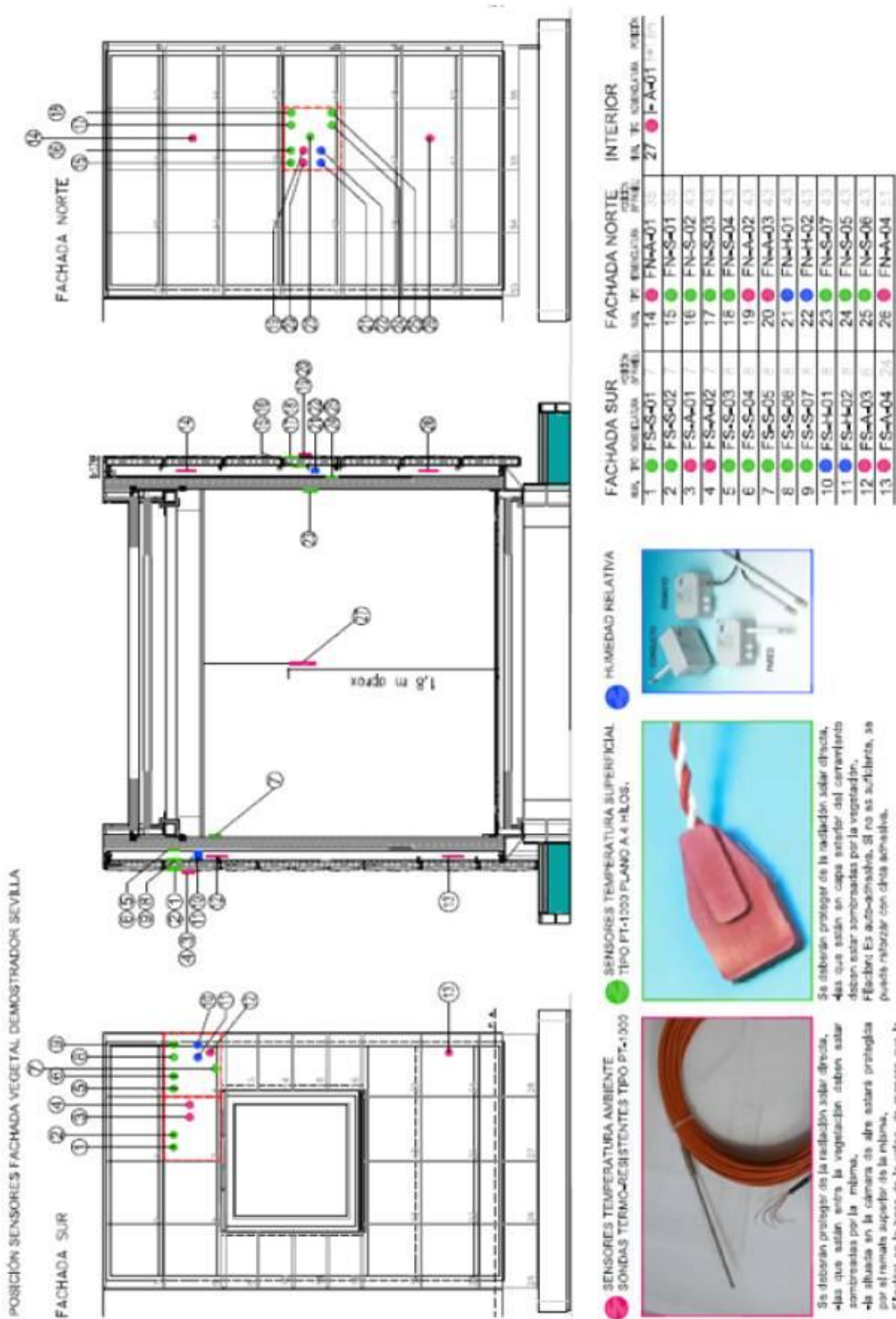

Fig. 2-17: Elevation showing the location of the different sensors to be deployed at the vegetated façade panels [DRA]

- **Acoustical performance (P-05 & P-07)**
  - o Acoustic measurements are complex: they require a noise emitting source, sound level meters, and intensive data collection. Quantitative tests are usually carried out under laboratory conditions, preferably in an anechoic chamber. Nevertheless, it may be interesting to undertake qualitative measurements in the Mock-up in order to test the improvements on the acoustical performance made by the special patterns engraved on the innermost GRC skin of the sandwich panels P-05 and P-07<sup>44</sup>.
- **Photovoltaic panels integration**
  - o PV panels are not connected since the objective was just to prove the Sandwich Framex concept: a façade panel that can be configured in a modular way up to customers' aesthetic and functional requirements with a range of external elements, and not to measure the performance of the PV panels. Yielded electricity could, of course, have been used to supply the Mock-up with electricity when demanded<sup>45</sup>, but the cost of the necessary equipment (inverters, etc.) makes it unworthy.

---

<sup>44</sup> These measurements are out of scope of this project, so it is up to SEIS if they contract the services of a specialized company to carry them out.

<sup>45</sup> With the electricity in excess, the following strategies could have been adopted:

- Inject the excess to the power grid, rewarded according to the Special Regime through a contract with the electric utility (watt-meters necessary to measure consumption and generation).
- Storage the electricity in batteries (suitable for isolated construction).
- Circuit is left open when there is no demand: no current flows and potential power is wasted.

## 2.3 Piping, water saving and fire extinguishing systems

- The proposal made by Uponor<sup>46</sup> for a residential water system comprises:
  - o Hot water system which minimizes the waste of water.
  - o Cold water system which has a sprinkler system integrated within it.
- Hot and cold water circuits configure a cost-effective installation, with flexible cross-linked polyethylene (PEX) pipes, Pipe-in-Pipe hidden installation, no joints or connections in the walls, secure couplings and connection boxes.

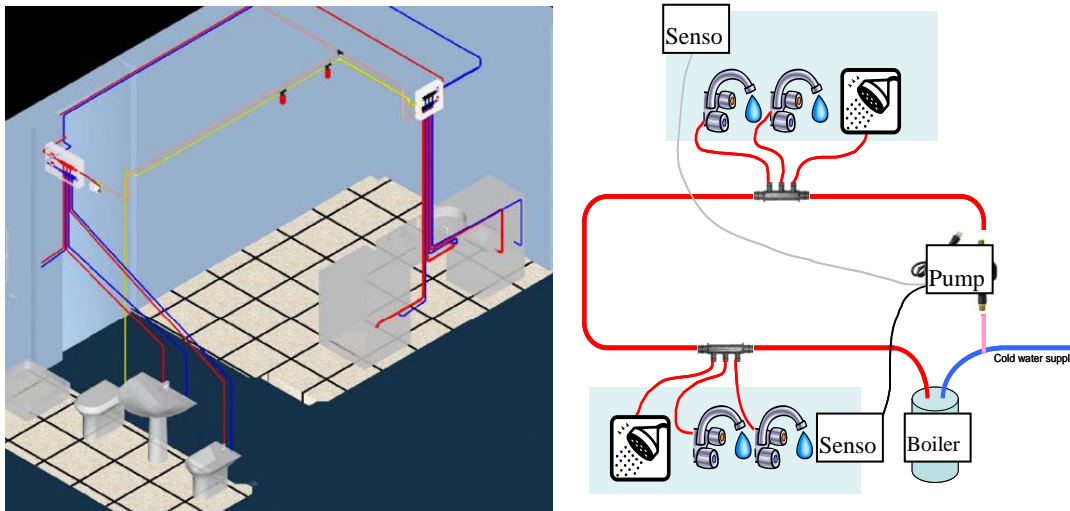

Fig. 2-18: Piping system [UPO]

### 2.3.1 Hot water system

The hot water system is designed for getting maximum benefits from a specific scenario: residential single family house with individual heating system, where there is usually a long distance (>15 m) from the boiler to the end point, usually a tap. These long distances mean that hot water in the pipe cools after some time, so when hot water is requested, at least the water in the line is wasted because its temperature is lower than the comfort one<sup>47</sup>.

According to Uponor's data, the annual water consumption for a typical 4-member family living in a detached or semi-detached house sums up to 200 m<sup>3</sup>, being the 35% (70.000 litres) used in personal hygiene. Table 2-4 displays information about the expenditure of domestic hot water (DHW) in several conditions. It shows that the waste of hot water represents an important percentage of the water used.

Table 2-4: Hot water waste Vs. Distance [UPO]

	Pipe ø (mm)	Heater – Distribution point Distance (metres)		
		5 m	10 m	15 m
Cold water volume in the pipe (litres)	20	4.07	8.14	12.21
	25	4.92	9.84	14.76
4 people / 2 times, day	20	32.57	65.15	97.72
	25	39.37	78.74	118.11
320 days / year	20	10423	20847	31270
	25	12598	25196	37794

<sup>46</sup> [www.uponor.com](http://www.uponor.com)

<sup>47</sup> This situation is simulated in the Mock-up by storing the water in a small (intermediate) water tank located on the roof.



- **Current solutions** for this problem, in the mentioned scenario, are:
  - o Install a hot water recirculation system, which works 100% of time. That system is designed as a central heating recirculation system.
  - o Install a hot water recirculation system, which works only part of the time, in order to reduce the energy consumption. It works with a timer, which activates the recirculation system at a pre-fixed time.
- These solutions have each their respective **disadvantages**:
  - o When there is a recirculation system working 100% of the time:
    - This system can work properly when there is a high hot water demand but, when applied to low demand circuits such as single-family homes, requires reheating the water with a heater, meaning high energy bills.
    - Circulation lines act like a radiator, meaning an increase of cooling load in warm weather (users demand hot water also in summer for showering, washing-up, etc.).
    - As the system is working 100% of the time, its components are excessively exposed to hot water.
  - o When there is hot water recirculation system working with a timer:
    - Since the system only works in the prefixed time, out of that timetable the system does not work and there are no savings.
    - Other common situation is to use the system more than needed, which implies the disadvantages of a hot water recirculation system working 100% of the time.

**Uponor's proposal** to solve this problem is a hot water recirculation system which works only when it is needed. This system is connected to the sensor network in the building, which activates the system when a person is within a predetermined area (bathroom or kitchen).

- **Advantages** of proposed DHW system are:
  - o Lower water bills, since less water is wasted.
  - o Lower sewer bills, if they are based on water consumption.
  - o Less waiting time for hot water (quick delivery of DHW in all taps connected to the loop).
  - o User determines when recirculation is needed. Adaptable to all lifestyles.
- **Operation**:
  - o In the Mock-up, DHW is provided by an instantaneous water heater (electric resistance submerged in a water tank).
  - o The recirculation pump installed at the Mock-up operates whenever one of the following situations occur:
    - Presence sensor in the bathroom is activated.
    - Water temperature inside the pipes is  $T < 47\text{ }^{\circ}\text{C}$  to prevent *Legionella* [39].
    - Note: The controlling system must also be able to deactivate this temperature-based activation to test the system using only the presence sensor.
  - o During the start-up tests, taps will be opened and closed on-site<sup>48</sup>.
  - o Metering devices are necessary for measuring cold and hot water consumption and comparison to Uponor's statistics.
- Note: One of the objectives is to check that the recirculation system works well when using external water temperature and presence sensors, instead of proprietary Uponor's systems. There already exists a recirculation pump, commercially available in the US that incorporates water temperature and occupancy sensors in order to work only when necessary [40].

---

<sup>48</sup> Faucets are conventional ones, but usage simulation can be carried out by actuating on electro-valves. Anyway, it is not intended to simulate real living, but to show that the DHW system works in conjunction with the monitoring & control systems and that the measurements are possible.

### 2.3.2 Cold water system & residential sprinklers

- The use of PEX pipes makes it possible to connect the Sprinkler System to the cold water system. This sprinkler system provides two advantages:
  - o It is quickly and easily installed, making for a cost-effective installation.
  - o The sprinkler system water supply is tested every time the connected section of the cold water supply is used. Every time the toilet is flushed, confirmation is provided that there is water in the system and that the sprinklers would function if a fire started.
- The sprinklers are activated when the ambient temperature reaches 68°C.
  - o The system is checked by WC flushing. This demonstrates how the system works, but not how well it performs<sup>49</sup>.
  - o In real building environments, a complementary fire alarm could be integrated within the BOS in order to alert the fire services whenever it is activated by the smoke from any fire, but this is not done in the Mock-up (no fire tests are going to be performed).

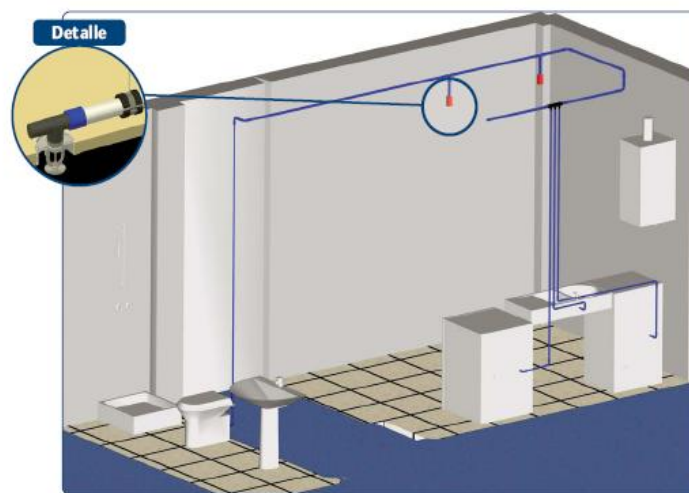

Fig. 2-19: Sprinklers integrated in cold water system [UPO]

<sup>49</sup> A flow -metering device would be needed to check that no calcium carbonate particles due to hard water are getting embedded inside the pipe. Accelerated tests are not considered.



## 2.4 Under-Floor Heating (UFH)

Over the floor concrete slab (*already described in § 2.1.1*) it is installed an under-floor radiant heating system<sup>50</sup> commercialized under the brand-name “Mini” [41]. The lay-out of the system designed for the Mock-up is depicted on *Fig. 2-20*. All the water pipes circuits are collected in a manifold chest as shown on *Fig. 2-21*.

- This UFH system stands out for needing only 15 mm from the base to the finishing tiles to be installed:
  - o 12 mm of plastic chambers guiding the water pipes with self-levelling screed surrounding the pipe guiding plate.
  - o 3 mm of levelling mortar over plate.
- The thermal inertia of this floor could be enhanced by mixing PCMs with the cement of the mortar, taking care that their content in the mixture doesn't affects negatively neither mortar's properties (setting, hardening, etc.) nor hinders floor tiling. Two forms were studied, although their application was declined<sup>51</sup>.
  - o Micro-capsules of PCM mixed with the cement.
  - o Granulated PCM, filling the gaps around the water pipes.

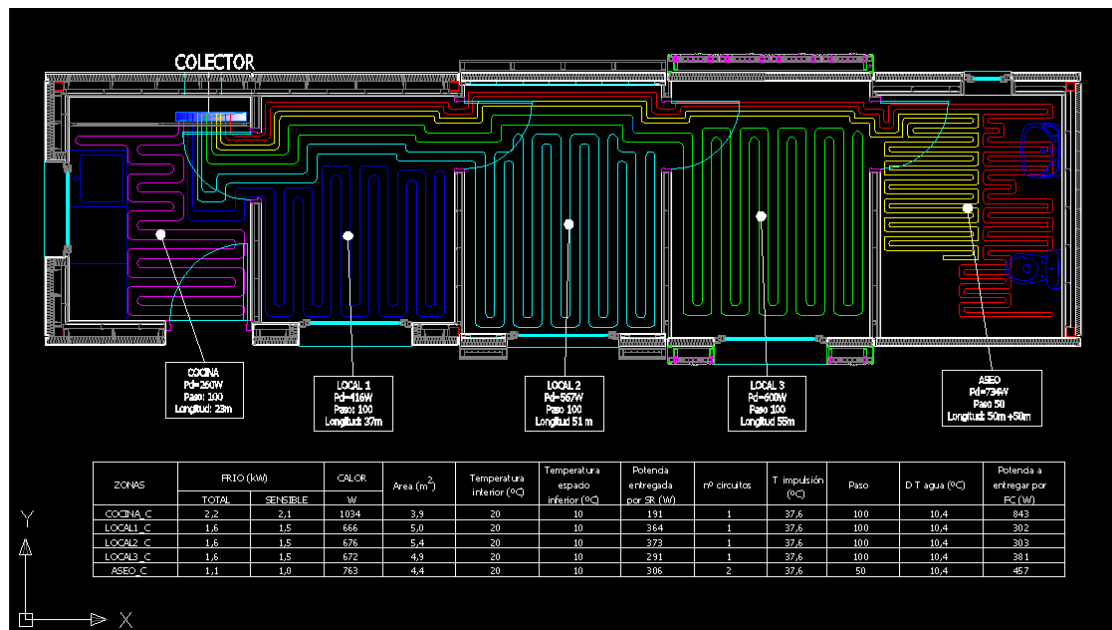
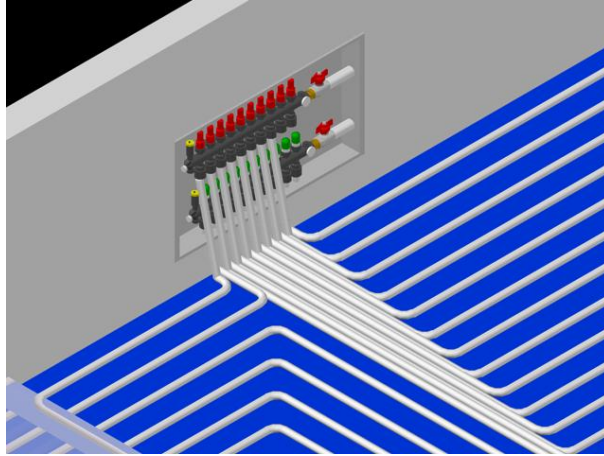

Fig. 2-20: Layout of the UFH system [DRA-UPO]

<sup>50</sup> Specifications of this system were detailed in an appendix (not to be disclosed) prepared by Uponor, including the following documentation:

- Calculations with different  $\Delta T$ .
- Virtual model of the tap water system.
- Demonstration activities suggested for single-family dwelling S. Cayetano.

<sup>51</sup> Technical decision backed up by José Luis Alfranca (Head of Building Installations Service, DRA).



*Fig. 2-21: Detail of the collector manifold for the UFH system [UPO]*

## 2.5 Electro-Chromic Glazing Unit (ECGU)

- The **Electro-Chromic Glazing Unit (ECGU)** is made of (Fig. 2-22):
  - o Two laminated EC glass plates (blue strips) in between of which there is Argon.
  - o A spacer (the thickest grey strip) hidden with black polymer.
  - o An inner pane (the cyan strip), which is a low emissivity pane [41].
- **Dimensions:** 992 x 998 x 24 mm (Drawing AR-17, Fig. 2-23 and Fig. 2-24).
  - o The total **thickness** of the ECGU is 24mm: laminated EC pane 8mm + spacer 12mm + inner pane 4mm (Fig. 2-22).
  - o 12mm is the minimum space necessary to hide the spacer. In case of a surface greater than 1m<sup>2</sup> it may be necessary 16mm. It is interesting to minimize this in order to increase the glazing surface.

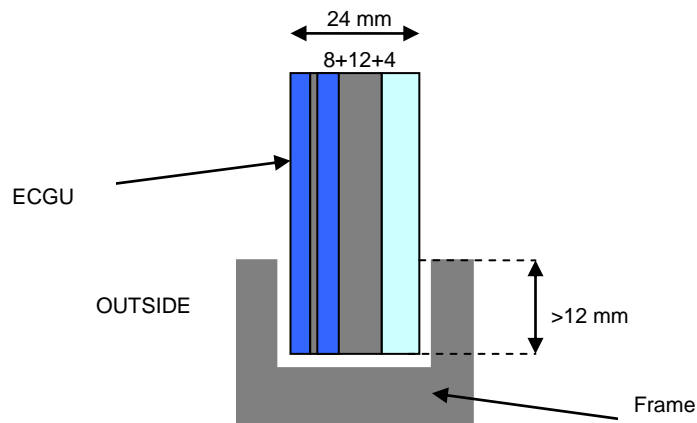

Fig. 2-22: Cross-section of the Electro-chromic glazing unit [SGR]

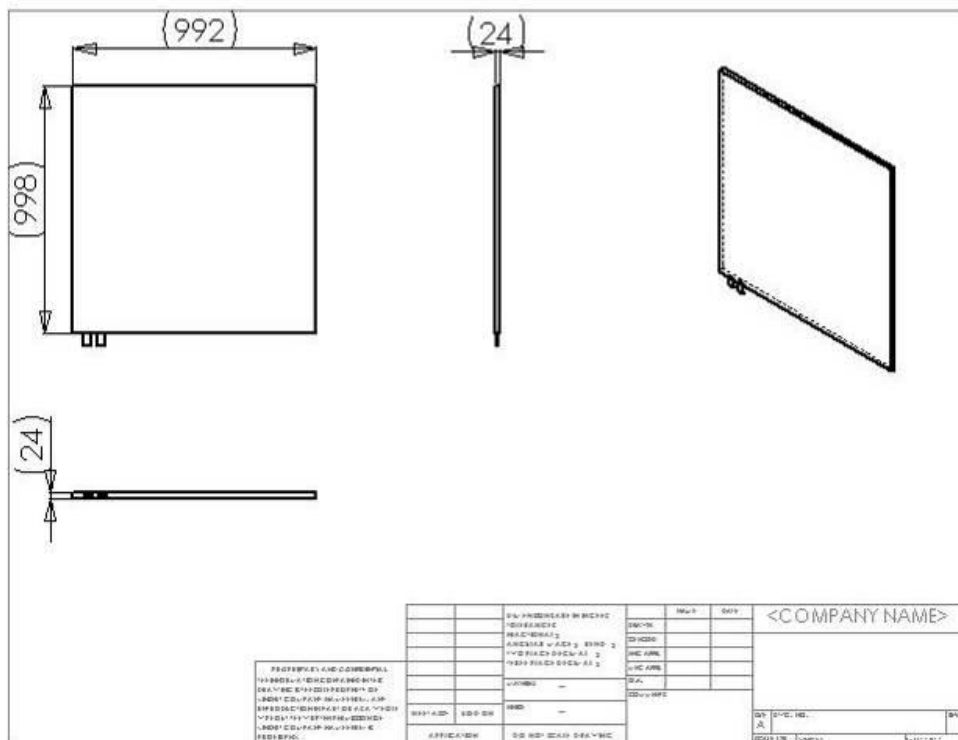
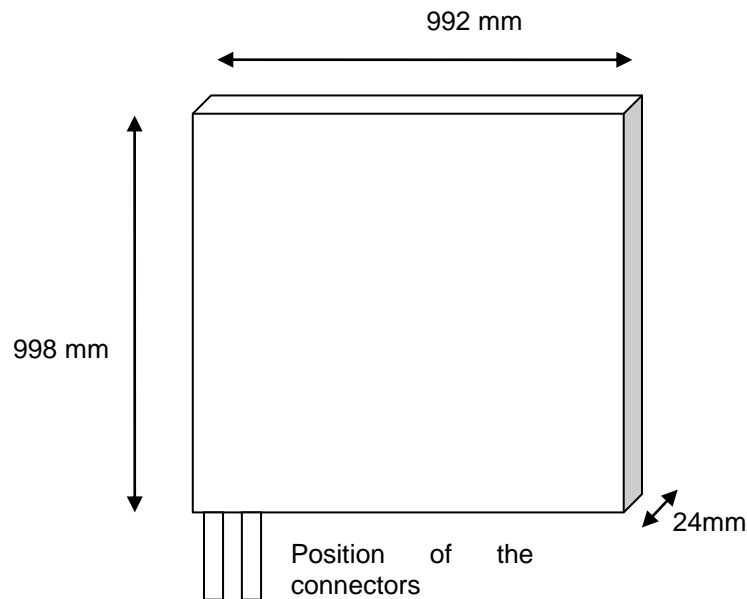

Fig. 2-23: Dimensions of the ECGU [SGR]



*Fig. 2-24: Front view of the Electro-chromic glazing plate [SGR]*

- **Properties** of the ECGU [43]:
  - o Thermal:
    - $U = 1.08 \text{ W/m}^2 \cdot \text{K}$
    - $Tl = 50\%$  in the clear state and  $2\%$  in the dark state.
    - Solar factor ( $g$ ) =  $6\%$  in the dark state and  $40\%$  in the clear state.
  - o Acoustical:
    - $R_w = 36 \text{ dB}$
    - $C = -1 \text{ dB}$
    - $C_{tr} = -4 \text{ dB}$
    - $R_a = 35.4 \text{ dB}$
    - $R_{a,tr} = 33.2 \text{ Db}$
  - o **Light transmission** of the glazing should present a shape similar to the one shown on *Fig. 2-25* (to be checked during the operation phase).
- **Assembly:**
  - o The size of the glazing makes it compatible with any commercial frame. Even so, special attention must be put to the wires going out of the glazing.
  - o Details of the metalwork in order to allow the cabling are shown on *Fig. 2-26*.
  - o Taking into account the thermal dilatation of the glazing, usually there is some free space in the frame (*Fig. 2-27*).
  - o Only one EC glazing unit with its controlling box was supplied by SGR. If it is wanted to be installed in another room, it will be necessary to change the window pane, the cabling and the control box in altogether.

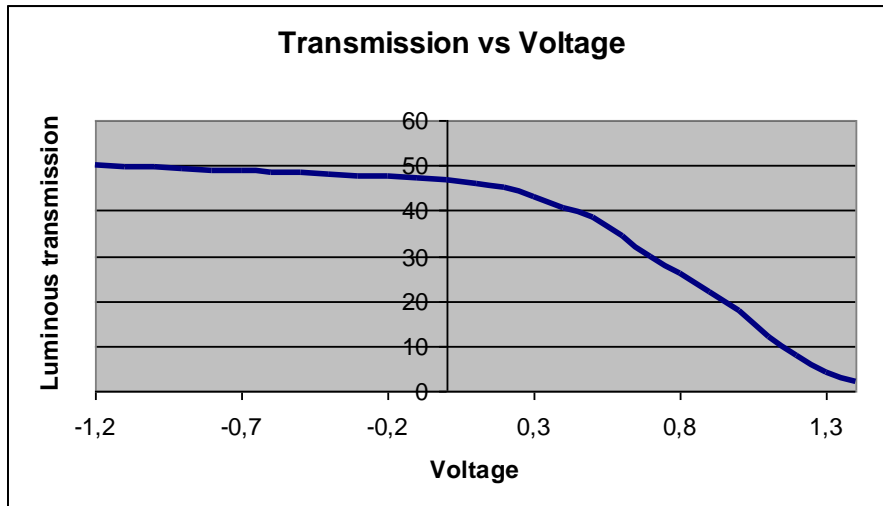

Fig. 2-25: Luminous transmission of the glazing depending on the applied voltage. Luminous transmission measured in the equilibrium state for a given voltage [SGR]

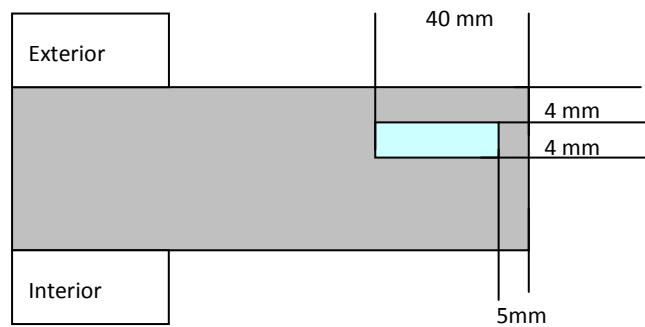

Fig. 2-26: Sketch of the hole to be drilled on the metalwork to allow the cables passing through: view of the bottom metallic frame [SGR]

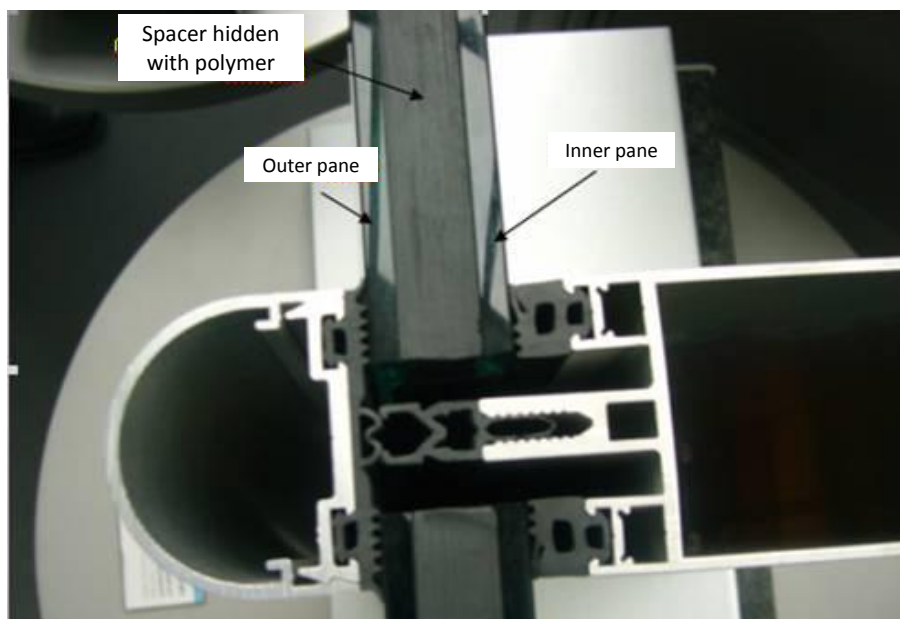
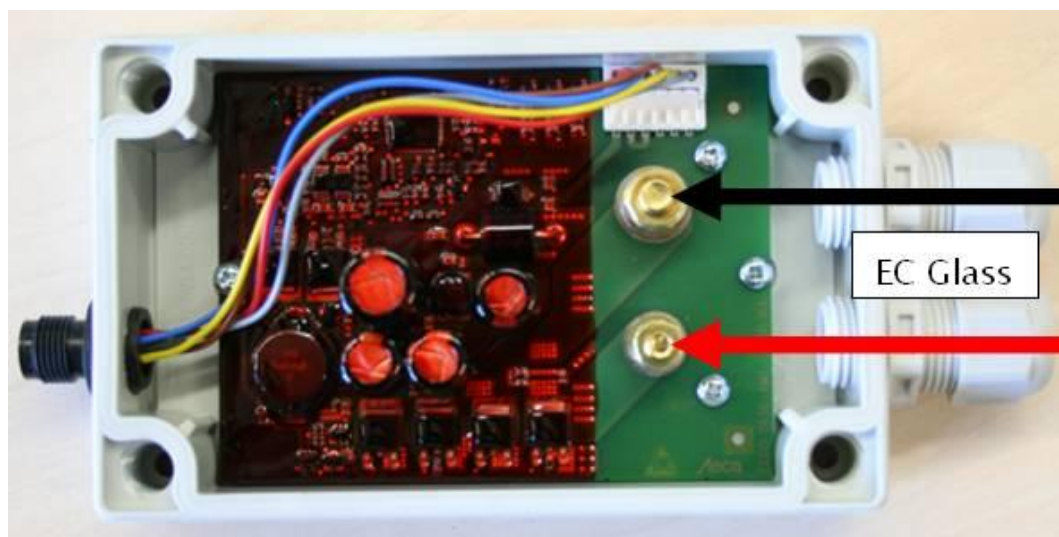

Fig. 2-27: Cross-section of a conventional glazing frame with simple glass as inner and outer pane [SGR]

- **Monitoring, control and operation:**
  - o **Sensors** needed [44]:
    - Temperature.
    - Occupancy.
    - Outside illuminance sensors for glare measurement: pyranometer (*see § 3.3.1*).
  - o **Control unit** requirements:
    - Power supply: it requires 12 Vdc.
    - Depending on the integration into the BMS chosen, some place (200x15x10 mm) for the power supply near the glazing has to be defined.
    - This power supply must be at a distance inferior than 1 meter to the glazing.
    - For controlling the shading degree, it must be able to deliver between -1.2 V to 1.4 V with a current of 2 A. If the current is lower than 2 A, the switching time may increase<sup>52</sup>.
    - *Fig. 2-28 and Fig. 2-29* show the automotive power supply, a diagram for the connectors and a description of the pins.
  - o **Control Strategy:** the power supply can deliver 3 different positions for the EC glazing: 1 for the clear state, 1 intermediate state and the complete coloured state. In order to make use of the whole potential of the electro-chromic glazing, it is advisable to have a dimmable lighting system controlled by the BOS (*Fig. 2-30*).
  - o **Operation:** the thermal transmission through the glazing for each one of 8 possible degrees of shading has already been done by SGR in lab conditions, so the ECGU in the Mock-up only features 3 degrees of shading which can be selected by:
    - The BOS according to the information of the sensor network by means of Light, Presence (occupancy) and indoor temperature sensors in room Local-1 (although it could be done also in rooms Local-2 and Local-3).
    - Users with a manual controller of the glazing level installed nearby the window.



*Fig. 2-28: 100x75mm automation power supply box [SGR]*

<sup>52</sup> In a first approach, if with 2 A the switching time is 2 minutes, with 1 A it will be 4 minutes, while with 0.5 A, 8 minutes; and so on.

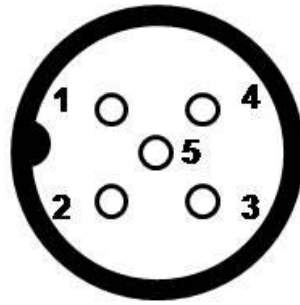

Fig. 2-29: Detail of the ECGU connector. There are 5 pins to control the power supply: two for the DC voltage (12 V) and three for the switch bit [SGR]

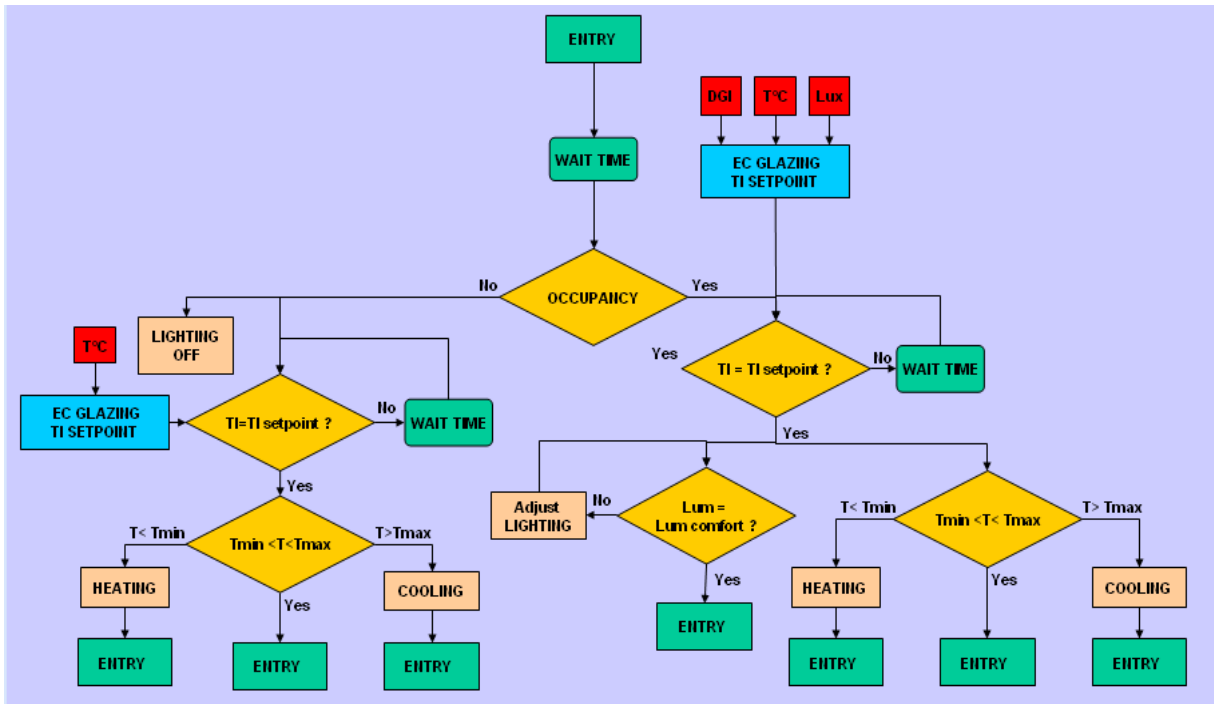

Fig. 2-30: Schematic representation of the control strategy [SGR]



## 2.6 Auxiliary Systems (HVAC Equipment)

The design of the systems has been done by external engineering consultants<sup>53</sup>. It is detailed in the draft of the Mock-up installations project (not to be disclosed), and in the drawings corresponding to the plumbing and HVAC systems (FO-xx and CL-xx).

- Solar thermal collectors: unpressurised and direct drain-back solar system based on a storage water tank [45], [46], [47] & [48].
- Plate heat exchanger.
- Air conditioning:
  - o Heat pump [49].
  - o Fan-coil units (FCU) [50] & [51]: five independent units<sup>54</sup>, so each room can be conditioned at will.
    - The performance of the different building enclosure systems is evaluated by setting the temperature to the same value, so there is no heat flux between the different rooms, and measuring the consumption of each FCU by means of calorie-meters (see § 3.2.4). The lower the consumption, the better the façade thermal behaviour.
  - o Five rotary mixing 3-way valves [52] and their corresponding actuators [53] (controlled by proportional signals 0÷10 V)<sup>55</sup>.
    - These devices are installed at the T-joint of the bypass existing at each FCU.

---

<sup>53</sup> ACH Consultoría SL. Benito Castro 10, Madrid. MEP Engineer: Juan Travesí Cabetas.

<sup>54</sup> Models FCL62 in the kitchen, FCL42 in the test rooms and FCL 36 in the bathroom.

<sup>55</sup> Rotary mixing 3-way valves VGR 131 and proportional actuator ARA 659P 24V.

## 2.7 Multi-Services Trunking System (MSTS)

The Multi-Services Trunking System (MSTS) comprises a set of runs and a distribution interface that is a “node” (not installed in the Mock-up). Due to difficulties in manufacturing the bundle of pipes, rapid-prototyping techniques were used.

- The plan for the demonstration consists of installing the assembled MSTS in the Mock-up, then connecting it to a number of services including air, hot and cold water, and electricity.
- Installation and location: anchored to the walls and sheltered with an acrylic glass<sup>56</sup> cabinet in the kitchen, in the corner between walls P-11 and P-12.
- The operation protocol of the MSTS servicing hot and cold water, ceiling air ventilation and electricity is described in § 5.2.1.

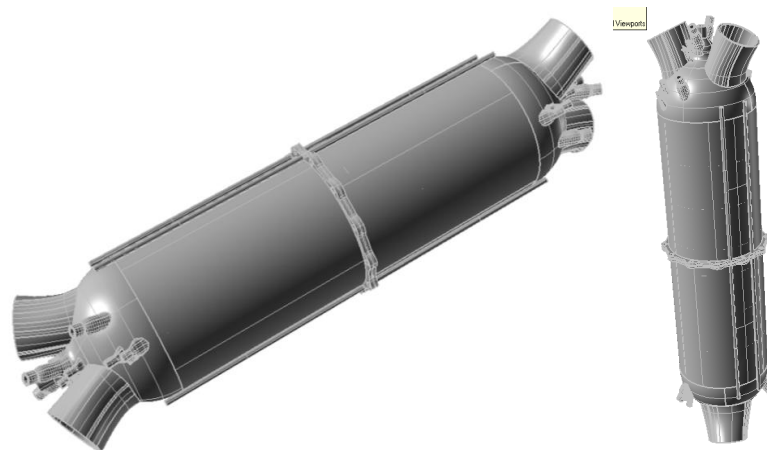

*Fig. 2-31: The MSTS, which is mounted in vertical position [LOU]*

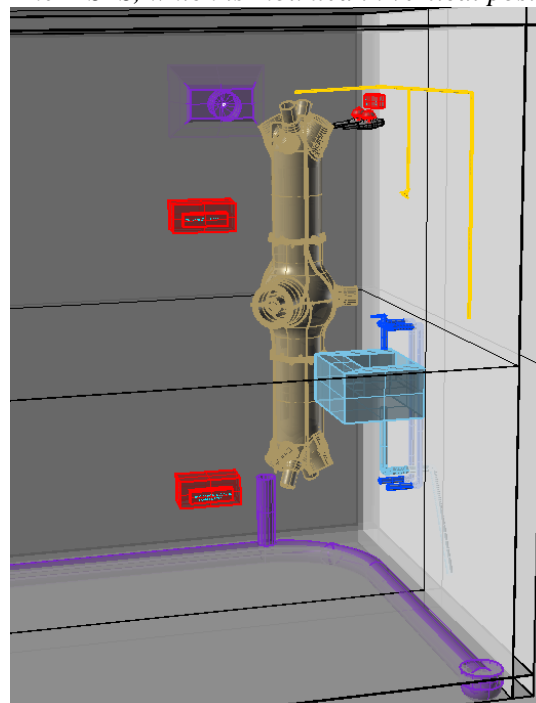

*Fig. 2-32: MSTS in a corner of the portable cabinet and the required pre-installed service to allow the testing within the Mock-up [LOU]*

<sup>56</sup> Poly-methyl methacrylate (PMMA) is used as an alternative to glass because of its moderate properties, easy handling and processing and low cost, although it behaves in a brittle manner when loaded.

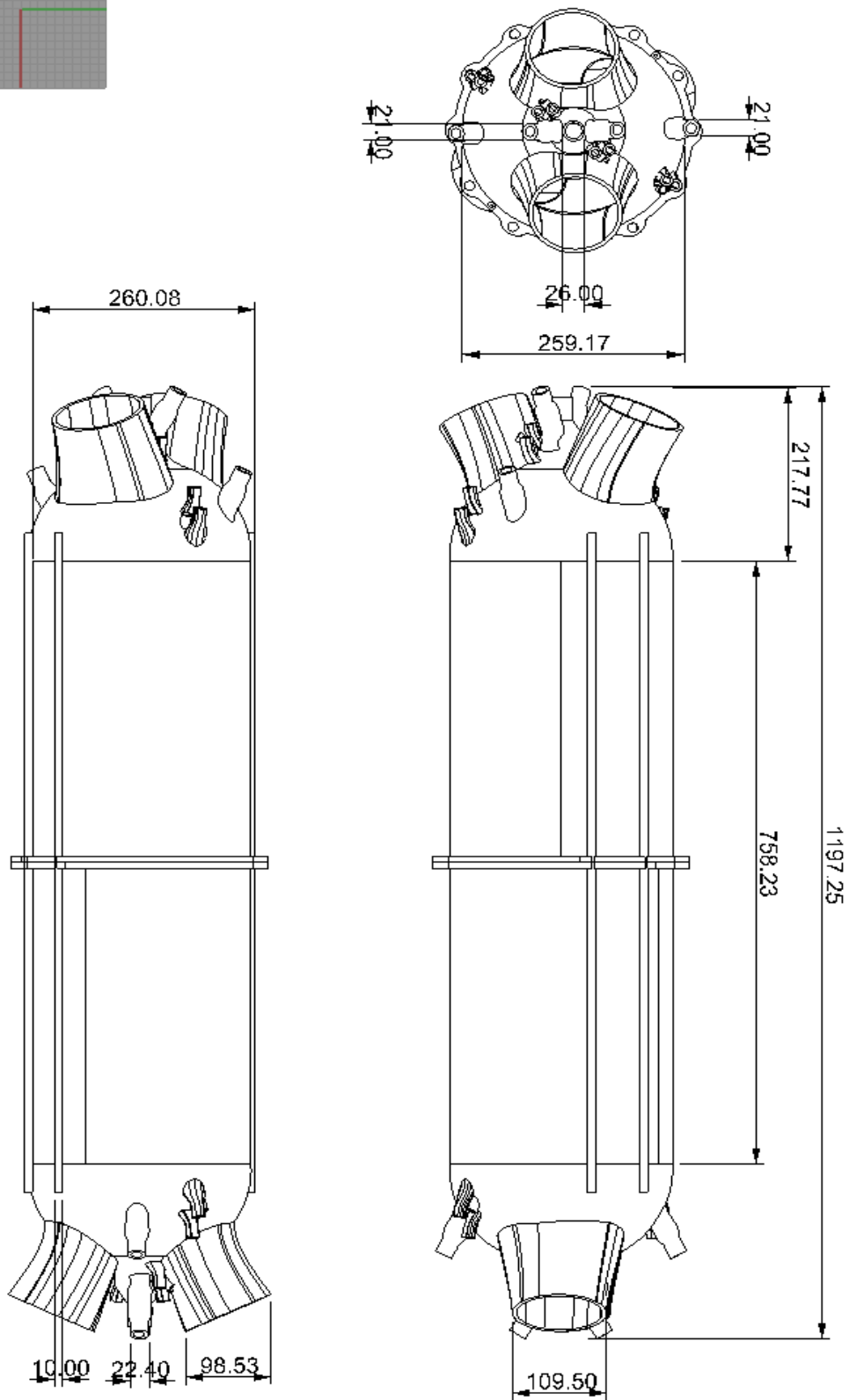
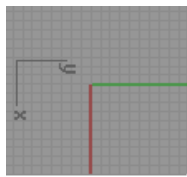

Fig. 2-33: Main dimensions of the MSTS [LOU]

## 3 Monitoring & Control systems

---

§ 3.1 presents the monitoring and control signals that have to be handled by the Mock-up Building Operating System (BOS) developed by Lonix (LON).

Given that the Mock-up is a space of reduced dimensions and that the number of sensors, metering devices and actuators is huge, it is very important to bear in mind that most of these items will have to be wired to and from the control modules and may require cables for power supply (§ 3.2.1). There are different pieces of equipment in the test rooms (Local-1, Local-2 & Local-3), the kitchen, the bathroom and the façade panels.

- The LON modules configure the core of the controlling part of the BOS (§ 3.2.2), but there is also some electrical equipment (§ 3.2.3) and metering devices (§ 3.2.4).
- The monitoring part of the BOS is made up by two networks of sensors:
  - o Wired sensors, deployed outdoors (§ 3.3.1), at the façade panels (§ 3.3.2), indoors (§ 3.3.3) and at the water pipes (§ 3.3.4).
  - o The Wireless Sensor Network (WSN) comprises units measuring CO<sub>2</sub> levels and human presence (§ 3.4.1) and humidity, light and temperature (§ 3.4.2). There is a base station, a gateway and a web server for the operation of the WSN (see §s from 3.4.3 to 3.4.5).

The Mock-up is intended to be monitored and controlled remotely. The ICT requirements to allow this are presented in § 3.5.

Finally, the objectives and the demonstration activities planned with the Mobile Productivity Tools developed by ICOM and the deployment of the necessary RFID tags are explained in § 3.6.

### 3.1 Monitoring & Control signals

The Mock-up BOS (Building Operating System) [54] handles numerous systems, equipment, metering devices, sensors, and actuators, resulting in many signals (inputs and outputs), both digital and analog. Following, these signals are listed.

- **Consumptions measured with metering devices:**
  - o Water:
    - Hot.
    - Cold.
  - o Electricity.
  - o Energy (calories or BTUs<sup>57</sup>).
- **Sensors deployed at different layers of the façade panels:**
  - o Ambient temperature.
  - o Surface temperature.
  - o Relative humidity degree.
- **Parameters measured with wired sensors:**
  - o Presence:
    - For controlling the electro-chromic glazing unit (ECGU).
    - For triggering the re-circulation pumps (water saving system).
  - o Ambient temperature:
    - Indoor.
    - Outdoor.
  - o Surface temperature:
    - Indoor.
    - Outdoor.
  - o Water temperature and flow:
    - In the DHW circuits (solar thermal collector + heat pump + under-floor heating).
    - In the re-circulation circuits (water saving system).
  - o Solar radiation flux density (pyranometer).
- **Parameters measured by the wireless sensor network:**
  - o **C:** CO<sub>2</sub> concentration.
  - o **P:** Presence by means of PIR (Passive Infra-Red) sensor.
  - o **H:** relative humidity degree.
  - o **L:** light level (illuminance, measurement unit: Lux).
  - o **T:** indoor ambient temperature.
- Signals from equipment devices (heat pump, water pumps, fan coil units, under-floor heating drives, dimmers, etc.):
  - o On/Off.
  - o Automatic/Manual.
  - o Alarm.
  - o Etc.

Note: see also installation drawings and the document that explains the BOS cabling and wiring diagrams (*Appendix V*).

---

<sup>57</sup> The calorie is a pre-SI metric unit of energy equal to about 4.2 joules. The British thermal unit (BTU or Btu) is a traditional unit of energy equal to about 1055 joules.

Table 3-1 gives a summary of the mock-up Monitoring & Control (M&C) elements, and the requirements in terms of power supply, connectivity and installation. The Location rows indicate how many units there are per room (Kitchen, Local-1, Local-2, Local-3 and Bathroom) and, in brackets, the partition wall or façade panel over which they are fitted<sup>58</sup>.

Table 3-1: Summary of the sensors, metering devices and equipment used for M&C [DRA]

System	Device	Supply	Connectivity	Installation/Location	K	1	2	3	B
BOS	Control panel	240 Vac	Multiple cables + Ethernet	Embedded H = 0.5 m	1 (K-1)				
BOS	Panel PC	240 Vac	Ethernet Internet	Embedded H = 1.5 m	1 (K-1)				
ELEC	Switchboard	240 Vac		Embedded H = 1.8 m	1 (K-1)				
ELEC	Lighting control (relays/LX-DIM-4)	240 Vac		Control panel	1 (K-1)				
ELEC	Lighting fixtures	240 Vac	Cables to the relays/LX-DIM-4	Technical ceiling Strips at both sides of fan-coil units	2	2	2	2	2
ELEC	Ballasts	24 Vdc	4-core cable from LON modules to each ballast 0÷10V control signal.	Between the BOS and the fluorescent strips	2	2	2	2	2
ELEC	Uninterrupted Power Supply	240 Vac		On the floor	1				
METERS	Hot water			Washbasin tap					1
METERS	Cold water			Water supply inlet	1				
METERS	Electricity			Switchboard	1				
METERS	BTUs			Fan-coil pipes, series connection	1	1	1	1	1
CABLE	Presence			Technical ceiling	1 (K-1)	1 (1-2)	1 (2-3)	1 (3-B)	1 (3-B)
CABLE	Indoor ambient Temperature			H = 1.8 m	1 (K-1)	1 (1-2)	1 (2-3)	1 (3-B)	1 (3-B)
CABLE	Outdoor ambient Temperature	18-35 V (DC) at unit (Loop powered <sup>59</sup> )	Wiring connections: screw terminals	To be decided on site			1		
CABLE	Temp. strap-on (thermal collector - heating system)	2-wire	2-wire	Mounted on metallic joints of PEX pipes by means of an adjustable tie	14 (P11)				
CABLE	Water temperature			Re-circulating circuit	1				1
FAÇADES	Indoor surface temperature		Cable	Innermost side of the gypsum plasterboards H = 0.5		2+2 (P02) (P10)			

<sup>58</sup> For instance, (K-1) refers to the partition wall between the Kitchen and the room Local-1. Outer walls are designated with the corresponding façade panel number (Pxx). The heights indicated for the installation correspond to the lowest point of the device, and are not prescriptive.

<sup>59</sup> There are 2 basic types of transmitters that can be connected to DCS/PLC or any controller: 2-wire and 4-wire. By 2-wire (loop powered) it means the transmitter is powered from the system to which it is connected. Normally 24 Vdc and 4÷20 mA signals are connected to the control system using only one single pair of wires. A 4÷20ma loop-powered device extracts the power it needs to run its circuits from the loop itself. There is no separate power feed from the Analog input card or from anywhere else. The current that the device draws becomes part of the 4 to 20 mA that flows in the loop, therefore the device must not require more than 4 mA to operate. By 4-wire (non-looped, or field powered) it means the transmitter is powered from a external power supply and signal 4÷20 mA, which is a separate pair of wires, is connected to the system.

System	Device	Supply	Connectivity	Installation/Location	K	1	2	3	B
FAÇADES	Indoor surface temperature		Cable	Innermost GRC skin			1+1 (P03) (P09)		
FAÇADES	Outdoor surface temperature		Cable	Studframe (exterior side)			2+2 (P03) (P09)		
FAÇADES	Outdoor ambient temperature		Cable	Ventilated chamber			1 (P03)		
FAÇADES	Temperature probe		Cable	Embedded in the PCM box in the core of the sandwich <sup>60</sup>			1+1		
FAÇADES	Outdoor ambient temperature		Cable	Vegetated modules				2+2 (P04) (P08)	
FAÇADES	Indoor ambient temperature		Cable	Close to the indoor face of the GRC sandwich, H = 1.7 m				1 (P04)	
FAÇADES	Ambient temperature		Cable	Ventilated chamber				2+2 (P04) (P08)	
FAÇADES	Indoor surface temperature		Cable	Indoor face of the GRC sandwich, H = 1.8-2.2 m				1+1 (P04) (P08)	
FAÇADES	Outdoor surface temperature		Cable	Outmost GRC skin; interior & exterior sides of the vegetated cells –attached to the wrapping felt				6+6 (P04) (P08)	
FAÇADES	Relative humidity		Cable	Ventilated chamber				2+2 (P04) (P08)	
HVAC	Heat pump	240 V (DC)		On the roof	1 (roof)				
HVAC	Flow switch			At the heat pump outlet pipe	1				
WSN	PC + monitor	240 V (AC) UPS	Ethernet Internet	On a table/shelf	1 (P12)				
WSN	Gateway / Server	240 V (AC) UPS	Ethernet Internet	Nearby the PC	1 (P12)				
WSN	Base station	5 V (DC) PoE	Aerial Ethernet	On a Shelf H=1.5m			1 (P09)		
WSN	C&P	9 V (DC)	Radio	Screwed H = 2.2 m	1 (K-1)	1 (1-2)	1 (2-3)	1 (3-B)	1 (3-B)
WSN	HLT	AA batteries (2 units)	Radio	Screwed H = 2.2 m	1 (K-1)	1 (1-2)	1 (2-3)	1 (3-B)	1 (3-B)
Outdoors	Pyranometer	14-30 V (DC)	-	-	1 (P02)				
Outdoors	Dry bulb & RH temp	-	-	On the roof, behind the parapet of the P-03					
ECGU	Control Unit	10-14 V (DC)		1 meter from the ECGU, embedded in the wallboard		1 (P02)			

<sup>60</sup> This will be finally done in a small model of the wall with only one PCM box in the core of a GRC sandwich, which will be compared with another one of the same characteristics but without PCM. See also Appendix VI.



Table 3-2 shows the LON Modules, the signal type (Digital/Analog and Input/Output, or if it is a metering –pulse Counter– device), the pin to be connected, the system which the signal belongs to, the associated equipment unit/device, the location of such unit, the name of the signal, and if this signal is being accessed from the MPTs (Mobile Productivity Tools) developed by ICOM.

Table 3-2: M&C signals handled by the BOS and accessed by the MPTs [DRA-ICOM-LON]

Module	Type	PIN	System	Device	Location	Signal	MPT
COUNTR	DIC	0	Domestic Cold Water	Istameter	Bathroom	Pulse meter reading	✓
COUNTR	DIC	1	Domestic Hot Water	Istameter	Kitchen	Pulse meter reading	✓
COUNTR	DI	2	Available position	-	-	-	-
COUNTR	DI	3	Available position	-	-	-	-
COUNTR	DIC	4	Façade panels	Istameter	P-04	FP-1	✓
COUNTR	DIC	5	Façade panels	Istameter	P-04	FP-2	✓
COUNTR	DIC	6	Façade panels	Istameter	P-08	FP-3	✓
COUNTR	DIC	7	Façade panels	Istameter	P-08	FP-4	✓
COUNTR	DI	8	Available position	-	-	-	-
COUNTR	DI	9	Available position	-	-	-	-
M01	DI	0	HVAC	Heat Pump	Roof	Run Status	✓
M01	DI	1	HVAC	Heat Pump	Roof	Pump Alarm	✓
M01	DI	2	HVAC	Flow Switch	Roof	FS01 Flow Switch	✓
M01	DI	3	Under-floor heating	B3 Pump	P-11	Run Status	✓
M01	DI	4	Under-floor heating	B3 Pump	P-11	Pump Alarm	✓
M01	DO	0	HVAC	Heat Pump	Roof	Cooling Permission	✗
M01	DO	1	Under-floor heating	UFH Collector	Room2	Floor Heating	✗
M01	DO	2	Under-floor heating	UFH Collector	Room3	Floor Heating	✗
M01	DO	3	Under-floor heating	UFH Collector	Room1	Floor Heating	✗
M02	DI	0	Heat exchanger	B1 Pump	P-11	Run Status	✓
M02	DI	1	Heat exchanger	B1 Pump	P-11	Pump Alarm	✓
M02	DO	0	HVAC	Heat Pump	Roof	Control	✗
M02	DO	1	Under-floor heating	B3 Pump	P-11	Control	✗
M02	AI	0	HVAC	Heat Pump	Roof	TE01 Supply	✓
M02	AI	1	HVAC	Heat Pump	Roof	TE02 Return	✓
M02	AI	2	Under-floor heating	UFH Collector	P-11	TE31 Supply	✓
M02	AI	3	Under-floor heating	UFH Collector	P-11	TE32 Return	✓
M02	AO	0	Under-floor heating	3way valve	P-11	TV02	✗
M02	AO	1	Under-floor heating	3way valve	P-11	TV01	✗
M04	DI	0	HVAC	Heat Pump	Roof	Cooling Indication	✓
M04	DI	1	Lights-dimmer		Room1	Dimmer On-off/Auto	✓
M04	DO	0	Electro-chromic glazing		Room1	ECG Binary3	✗
M04	DO	1	Electro-chromic glazing		Room1	ECG Occupied	✗
M04	AI	0	Outdoor sensors			TE Outside Temp Dry	✓
M04	AI	1	Wired sensors		Room1	Temp	✓

Module	Type	PIN	System	Device	Location	Signal	MPT
M04	AI	2	Outdoor sensors			Outside Humidity	✓
M04	AI	3	Façade panels		P-10	Surface Temp1	✓
M04	AO	0	Under-floor heating		Room1	Heating	✗
M04	AO	1	Electro-chromic glazing		Room1	ECG	✗
M05	DI	0	Wired sensors		Room1	PIR	✓
M05	DI	1	Lights-dimmer		Room1	Dimmer Manual	✓
M05	DO	0	Electro-chromic glazing		Room1	ECG Binary1	✗
M05	DO	1	Electro-chromic glazing		Room1	ECG Binary2	✗
M05	AI	0	Wired sensors		Room1	Lux Level	✓
M05	AI	1	Façade panels		P-04	Surface Temp1	✓
M05	AI	2	Façade panels		P-04	Surface Temp2	✓
M05	AI	3	Façade panels		P-04	Surface Temp3	✓
M05	AO	0	Electro-chromic glazing		Room1	ECG Unoccupied	✗
M05	AO	1	HVAC	FCU-1	Room1	Cooling	✗
M06	DI	0	Wired sensors		Room2	PIR	✓
M06	DI	1	Lights-dimmer		Room2	Dimmer On-off/Auto	✓
M06	DO	0	Electro-chromic glazing		Room2	ECG Binary3	✗
M06	DO	1	Electro-chromic glazing		Room2	ECG Occupied	✗
M06	AI	0	Façade panels		P-04	Surface Temp4	✓
M06	AI	1	Wired sensors		Room2	Temp	✓
M06	AI	2	Façade panels		P-04	Surface Temp5	✓
M06	AI	3	Façade panels		P-04	Surface Temp6	✓
M06	AO	0	HVAC	FCU-2	Room2	Heating	✗
M06	AO	1	Electro-chromic glazing		Room2	ECG	✗
M07	DI	0	Heat exchanger	B2 Pump	P-11	Run Status	✓
M07	DI	1	Heat exchanger	B2 Pump	P-11	Pump Alarm	✓
M07	DO	0	Electro-chromic glazing		Room2	ECG Binary1	✗
M07	DO	1	Electro-chromic glazing		Room2	ECG Binary2	✗
M07	AI	0	Wired sensors		Room2	Lux Level	✓
M07	AI	1	Façade panels		P-04	Surface Temp7	✓
M07	AI	2	Façade panels		P-04	Humidity1	✓
M07	AI	3	Façade panels		P-08	Surface Temp1	✓
M07	AO	0	Electro-chromic glazing		Room2	ECG Unoccupied	✗
M07	AO	1	HVAC	FCU-2	Room2	Cooling	✗
M08	DI	0	Lights-dimmer		Room3	Dimmer Manual	✓
M08	DI	1	Lights-dimmer		Room3	Dimmer On-off/Auto	✓
M08	DO	0	Electro-chromic glazing		Room3	ECG Binary3	✗
M08	DO	1	Electro-chromic glazing		Room3	ECG Occupied	✗
M08	AI	0	Façade panels		P-08	Surface Temp2	✓
M08	AI	1	Wired sensors		Room3	Temp	✓

Module	Type	PIN	System	Device	Location	Signal	MPT
M08	AI	2	Façade panels		P-08	Surface Temp3	✓
M08	AI	3	Façade panels		P-08	Surface Temp4	✓
M08	AO	0	HVAC	FCU-3	Room3	Heating	✗
M08	AO	1	Electro-chromic glazing		Room3	ECG	✗
M09	DI	0	Wired sensors		Room3	PIR	✓
M09	DI	1	Available position				-
M09	DO	1	Electro-chromic glazing		Room3	ECG Binary1	✗
M09	DO	1	Electro-chromic glazing		Room3	ECG Binary2	✗
M09	AI	0	Wired sensors		Room3	Lux Level	✓
M09	AI	1	Façade panels		P-08	Surface Temp5	✓
M09	AI	2	Façade panels		P-08	Surface Temp6	✓
M09	AI	3	Façade panels		P-08	Surface Temp7	✓
M09	AO	0	Electro-chromic glazing		Room3	ECG Unoccupied	✗
M09	AO	1	HVAC	FCU-3	Room3	Cooling	✗
M10	DI	0	Wired sensors		Toilet	PIR	✓
M10	DI	1	Available position				-
M10	DO	0	Under-floor heating		Toilet	Floor Heating	✗
M10	DO	1	Available position				-
M10	AI	0	Wired sensors		Toilet	Temp	✓
M10	AI	1	Façade panels		P-08	Humidity1	✓
M10	AI	2	Façade panels		P-10	Surface Temp2	✓
M10	AI	3	Domestic Hot Water	PU2		TE42 Return	✓
M10	AO	0	HVAC	FCU-B	Toilet	Heating	✗
M10	AO	1	HVAC	FCU-B	Toilet	Cooling	✗
M11	DI	0	Domestic Hot Water	PU1		Pump Alarm	✓
M11	DI	1	Domestic Hot Water	PU2		Pump Alarm	✓
M11	DO	0	Heat exchanger	B1 Pump		Control	✗
M11	DO	1	Heat exchanger	B2 Pump		Control	✗
M11	AI	0	Solar thermal collector	Rotex		TE13 Solar Supply	✓
M11	AI	1	Solar thermal collector	Rotex		TE14 Solar Return	✓
M11	AI	2	Solar thermal collector	Rotex		TE11 DHW Supply	✓
M11	AI	3	Solar thermal collector	Rotex		TE12 DHW Return	✓
M11	AO	0	Domestic Cold Water	Electrovalves		DCW Sim1	✗
M11	AO	1	Domestic Cold Water	Electrovalves		DCW Sim2	✗
M12	DI	0	Wired sensors		Kitchen	PIR	✓
M12	DI	1	Available position				-
M12	DO	0	Under-floor heating		Kitchen	Floor Heating	✗
M12	DO	1	Available position				-
M12	AI	0	Wired sensors		Kitchen	Temp	✓
M12	AI	1	Façade panels		P-02	Surface Temp1	✓
M12	AI	2	Façade panels		P-02	Surface Temp2	✓

Module	Type	PIN	System	Device	Location	Signal	MPT
M12	AI	3	Domestic Hot Water	PU1		TE41 Return	✓
M12	AO	0	HVAC	FCU-K	Kitchen	Heating	✗
M12	AO	1	HVAC	FCU-K	Kitchen	Cooling	✗
M13	DI	0	Domestic Hot Water	PU1	?	Run Status	✓
M13	DI	1	Domestic Hot Water	PU2	?	Run Status	✓
M13	DO	0	Domestic Hot Water	PU1	?	Return PU1 Control	✗
M13	DO	1	Domestic Hot Water	PU2	?	Return PU2 Control	✗
M13	AI	0				TE23 IP1 Supply	✓
M13	AI	1				TE24 IP1 Return	✓
M13	AI	2				TE21 DHW Supply	✓
M13	AI	3				TE22 DHW Return	✓
M13	AO	0	Domestic Hot Water			DHW Sim1	✗
M13	AO	1	Domestic Hot Water			DHW Sim2	✗
M14	DI	0	Available position				-
M14	DI	1	Available position				-
M14	DO	0	Lights-dimmer		Room1	Dimmer Manualstop	✗
M14	DO	1	Available position				-
M14	AI	0	Façade panels		P-03	Ambient Temp	✓
M14	AI	1	Façade panels		P-03	Surface Temp1	✓
M14	AI	2	Façade panels		P-03	Surface Temp2	✓
M14	AI	3	Façade panels		P-03	Surface Temp3	✓
M14	AO	0	Lights-dimmer		Room1	Ballast	✗
M14	AO	1	Available position				-
M15	DI	0	Lights-dimmer		Room2	Dimmer Manual	✓
M15	DI	1	Available position				-
M15	DO	0	Lights-dimmer		Room2	Dimmer Manualstop	✗
M15	DO	1	Available position				-
M15	AI	0	Façade panels		P-09	Surface Temp1	✓
M15	AI	1	Façade panels		P-09	Surface Temp2	✓
M15	AI	2	Façade panels		P-09	Surface Temp3	✓
M15	AI	3	Façade panels		P-04	Ambient Temp1	✓
M15	AO	0	Lights-dimmer		Room2	Ballast	✗
M15	AO	1	Available position				-
M16	DI	0	Available position				-
M16	DI	1	Available position				-
M16	DO	0	Lights-dimmer		Room3	Dimmer Manualstop	✗
M16	DO	1	Available position				-
M16	AI	0	Façade panels		P-04	Ambient Temp2	✓
M16	AI	1	Façade panels		P-04	Ambient Temp3	✓
M16	AI	2	Façade panels		P-04	Ambient Temp4	✓
M16	AI	3	Façade panels		P-04	Ambient Temp5	✓

Module	Type	PIN	System	Device	Location	Signal	MPT
M16	AO	0	Lights-dimmer		Room3	Ballast	✗
M16	AO	1	Available position				-
M17	DI	0	Available position				-
M17	DI	1	Available position				-
M17	DO	0	Available position				-
M17	DO	1	Available position				-
M17	AI	0	Façade panels		P-08	Ambient Temp1	✓
M17	AI	1	Façade panels		P-08	Ambient Temp2	✓
M17	AI	2	Façade panels		P-08	Ambient Temp3	✓
M17	AI	3	Façade panels		P-08	Ambient Temp4	✓
M17	AO	0	Available position				-
M17	AO	1	Available position				-
M18	DI	0	Available position				-
M18	DI	1	Available position				-
M18	DO	0	Available position				-
M18	DO	1	Available position				-
M18	AI	0	Façade panels		P-08	Humidity2	✓
M18	AI	1	Façade panels		P-04	Humidity2	✓
M18	AI	2	Outdoor sensors	Pyranometer	P-02	Solar radiation	✓
M18	AI	3	Available position				-
M18	AO	0	Available position				-
M18	AO	1	Available position				-

## 3.2 Building Operating System (BOS)

### 3.2.1 Control signals & wiring scheme

- **Abbreviations** in the cabling documentation (*Appendix V*):
  - o G0 is ground.
  - o TE is for technical earth. What it basically means is that the low voltage (LV) cabling is recommended to have a separate grounding from the high voltage (HV) cabling because of interference.
  - o Y is 0÷10V signal. This is for transducers (0÷10V measurements).

Signals from the different pieces of equipment fitted in the test rooms, kitchen and bathroom, and façade panels handled by the Mock-up BOS are explained in the following epigraphs.

#### 3.2.1.1 Equipment

- **Meters** (see § 3.2.4)
  - o Hot water.
  - o Cold water.
  - o Electricity meter.
  - o Energy (calorie-meter).
- **Heat pump:** refer to installation manual [55], controlling instructions [56] and wiring diagrams [57]) to check that the model supports the following signals:
  - o On / Off.
  - o Alarm.
  - o Control signal.
  - o The liquid flow switch [58] & [59] confirms the flow of the fluid (water) in the pipe as the run status signal from the pump can only tell if the heat pump is on or off.
    - The flow switch is provided by Lonix and supports LonWorks protocol.
- **Cooling indication & Cooling permission:** these signals are for temperature control logic (FCU + floor heating). They are necessary for the temperature controllers, as one is for heating and another one for cooling only.
  - o Cooling Permission is a relay that is turned on when the indoor temperature is over the set value. Therefore, when this signal is not activated, the heat pump works in the heating mode.
  - o The same relay is then connected to LON module's digital input (Cooling Indication). This is just a workaround to simplify the control logic and number of Inputs/Outputs used.
- **Water Pumps** signals<sup>61</sup>: B1 (UFH impulsion) [60], B2 (from the hot water deposit to the heat exchanger) [61] and B3 (return from the exchanger to the HVAC/UFH Collector) [62]:
  - o On/Off (relay is open or closed).
  - o Alarm. The alarms for the pumps are being deployed so that they are triggered when the pump goes from closed to open: if the protection detects a fault, it opens the circuit and triggers the alarm<sup>62</sup>.
  - o Control signal (reading from the switchboard, it tells if the circuit is open or closed).

---

<sup>61</sup> Pumps B1, B2 & B3 don't give information neither about "On/Off" nor "Alarm". It is only possible to control them by actuating on their respective relays. These signals (run status, alarm), are typically available from a small panel that is located on the pump itself. However, they are not mandatory, and it would not be a big deal if they were not available.

<sup>62</sup> LON digital inputs can be configured for NO (Normally Open) or NC (Normally Closed) so it could also have been the other way around.



### 3.2.1.2 Test rooms: Local-1, Local-2 & Local-3

- **Under-floor heating:** The thermal actuators for floor heating are 24 Vdc drives connected directly to Lonix controller modules. They are operated with PWM<sup>63</sup>.
- **Lights/dimmers:**
  - Dimmer Auto/Off.
  - Dimmer Manual.
  - Dimmer Manualstop is a signal necessary for the logic system (it is not connected anywhere). The two switches are connected to Dimmer Auto/Off and Dimmer Manual.
- **Electro-chromic glazing:**
  - ECGU Binary 1, 2 & 3 (3 signals).
  - ECGU Occupied is an analog output.
  - ECGU Unoccupied is a digital output.
  - The ECGU will be controlled with the 3 relays “ECG BinaryX”. ECG Occupied and ECG Unoccupied are logical signal (not connected physically by a wire anywhere).
- **Fan-coil units (FCUs):**
  - The motorized valves of the FCUs are controlled by the two analogue outputs: Room-X Heating & Room-X Cooling. It can be seen, in the Cabling document (*Appendix V*), that these outputs control 24 Vac valves, so a transformer is needed.
  - There are Heating and Cooling signals for each one the FCUs. These outputs operate the valves in the FCUs, allowing more or less water flow in the circuit depending on how much we want to heat/cool.
    - **Note:** These signals are redundant; once you know if the system is in the heating or cooling mode, then you only have to tell “how much” power you want, so there will be only one valve.
    - **Note:** The FCUs are standalone and cannot be connected to LON system. It was agreed that a bypass circuit for the coil would be installed so the amount of water entering the FCU can be controlled. Both cooling and heating signals should be connected to this same valve (this is necessary because of the control logic).
- **Bulb temperatures:**
  - Dry bulb temp is used for deciding if the FCUs are used for cooling or heating. It is obtained from the LX-RTE-O sensor (*see §3.3.1*).
  - Wet bulb temp is only for information and is not going to be finally deployed<sup>64</sup>.
- **Temperature, occupancy and lux level:** The wired sensors are supplied by Lonix, and they are duplicating the information from the WSN. Note that Thales’ wireless sensors (HLT and C&P) are not visible in this configuration because they are integrated at the BOS level.

---

<sup>63</sup> Pulse-Width Modulation (PWM) provides intermediate amounts of electrical power between fully on and fully off. You can connect the actuator directly to Lonix modules or better yet, connect only (–) to Lonix module and (+) directly to +24 Vdc as there is a 250 mA limitation of how much power each module can supply. The proper I/O is named “xxx Floor Heating” in the cabling document (*Appendix V*), e.g. thermal actuator for Room1 would be connected to controller module M01, terminals 16+/18–.

<sup>64</sup> The wet bulb temperature was supposed to be obtained through the weather station, finally discarded. This position in the control modules was occupied by the outdoor relative humidity signal coming from the LX-RTE-O sensor.

### 3.2.1.3 Kitchen and Bathroom

- (Under) floor heating: same as above.
- The lights in the kitchen/bathroom are not controlled as there is no electro-chromic glazing unit present and the lights can be controlled manually (hence, there is no signal for the ECGU neither for the dimmers).
- The motorized valves of the FCUs are controlled in the same way as for the test rooms.
- **Temperature, occupancy and lux level:**
  - o Temperature (wired sensor supplied by LON), as in test rooms.
  - o PIR sensors: trigger the re-circulation pumps PU1 y PU2 of the water saving system.
    - Alarm.
    - On / Off.
    - DHW return control (measurement of the temperature for controlling the pump, e.g. TE41).
  - o Note: Wireless sensors supplied by TRT (HLT and C&P) are not visible in this configuration because they are integrated on the BOS level.
- **3-way valves TV01 & TV02 (proportional outputs):** control the temperature for DHW and floor heating circuits via heat exchangers.
  - o Note: Two- and three-way valves have 2 wires + ground while in the wiring diagrams there are 3 wires + ground. Looking at the wiring diagrams, it seems like two wires are for controlling the state of the pump (i.e. pins 14 and 12 for TV01) and the third one is for power supply (24 V in the pin 4 of the Multimodule)<sup>65</sup>.
- **DHW and cold water consumption simulation:** The following signals control the water outlets. It is not necessary to purchase a tap with remote control features: they can be controlled by any standard valve actuator (similar to other in the project compatible with the BOS). When the tap is left open, the water flowing through it can be controlled by actuating the valve connected to the supply pipe and simulate water consumption.
  - o DCW sim1.
  - o DCW sim2.
  - o DHW sim1.
  - o DHW sim2.

### 3.2.1.4 Façade panels

In summary, the following sensors have to be deployed in order to measure the effect of PCMs and vegetation (*more details in § 3.3*):

- **P-02 & P-10** (micro-capsules of PCM in the plasterboard sheathing):
  - o 4 surface temperature sensors Pt-1000.
- **P-03 & P-09** (plastic boxes filled with PCM, embedded in the core of the sandwich panels).
  - o 1 ambient temperature sensor located at the buffer space of the south façade.
  - o 6 surface temperature sensors (3 per façade panel).
- **P-04 & P-08** (vegetated panels):
  - o 6 ambient temperature sensors Pt-1000.

---

<sup>65</sup> Lonix suggested that it would be better to take the power for the valves from the DDC panel terminals, not from the module pins 4 and 5. The third wire is the 0÷10 V in reference with the ground. The third wire can be connected to the (+) of AO (pin 14) and module's pins 5 and 11 can be connected with a jumper cable.

- o 10 surface temperature sensors Pt-1000.
- o 4 relative humidity sensors.

### 3.2.2 BOS Equipment

- **Direct Digital Control (DDC) panel:**
  - o LON modules and relays are installed in this box; the cables for the sensors, metering devices and lighting fixtures are pulled from here.
  - o Dimensions: 30x50x15 cm (this size may change since the system can be extended with new modules).
  - o Location: in the kitchen (K), embedded in the partition wall between the kitchen and the room Local1 (K-1), behind the door, at a height  $H = 0.5$  m.
- **LON modules:**
  - o Counter module [65].
  - o Digital module [66].
  - o Multi-modules [67].
- **Relays** with their corresponding bases [68]:
  - o 24 V /10 A.
  - o 24 V /16 A: these are 3-phase relays for controlling the circulation pump.
  - o It is also necessary to control the fan coil units by means of relays. The relays must be able to bear the power consumed by the FCUs, and the switching current must be less than 250 mA (this value is limited by the LON modules).
  - o All of them are fitted in the DDC panel.
- **Gateway** (network interface LonWorks-TCP/IP) [69]:
  - o Supply: 230 Vac / 24 Vdc.
  - o Connectivity: Ethernet cable and LON cables/interfaces<sup>66</sup>.
  - o Location: it does not have to be placed in the DDC panel.
- **PC connector:**
  - o For hooking up a laptop with the LON bus.
  - o Installation and location: it needs 1.2 cm of DIN rail<sup>67</sup> to be fitted in the DDC panel.
- **Touch screen computer** (Panel PC AFL-12B-9103, *Fig. 3-1 and Fig. 3-2*) [70]:
  - o Functions: BOS server / User interface.
  - o Power supply: 12 Vdc.
  - o Connectivity: Ethernet cable.
  - o Installation and location:
    - Kitchen, embedded in the partition wall K-1 (there is no need of ventilation since it is a “fan-less” model).
    - Height  $H = 1.5$  m; care must be taken that it is not hidden by the entrance door of the Mock-up when it is open.
- **Control Cable:** any standard instrumentation cable<sup>68</sup> [71].

---

<sup>66</sup> According to the information provided during the early design stages, one of the requirements of the DDC panel was M-Bus line-power supply and RS-232 level converter for M-bus devices, but according to the latest specifications the meters are connected directly to LON via an appropriate interface.

<sup>67</sup> Standardized (EN 50022) 35 mm wide metal rail with hat-shaped cross section, widely used for snap-on mounting low voltage control and switchgear equipment inside racks.

<sup>68</sup> Lonix indicated KLMA 2 x 0,8 + 0,8 AWG20, shielded, not twisted. It is quite difficult to find this type of cable in the Spanish market. A similar one, but twisted, was finally employed.

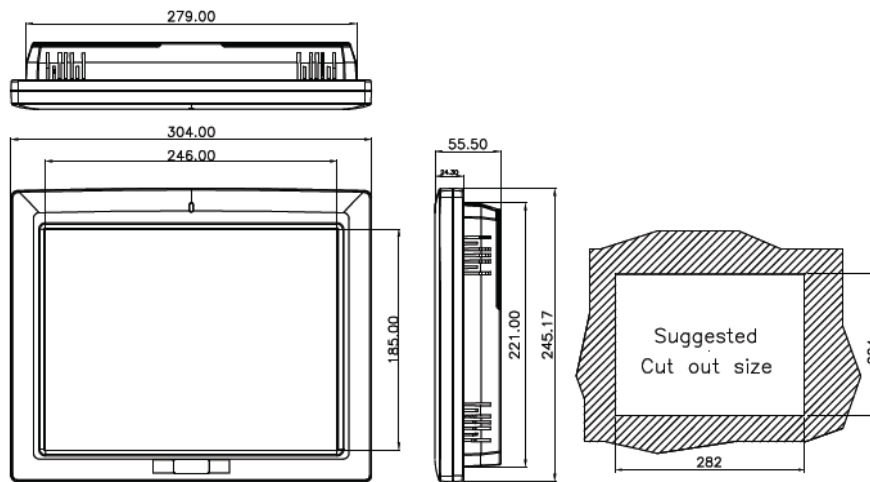

Fig. 3-1: Panel PC dimensions (in mm) [Afolux]

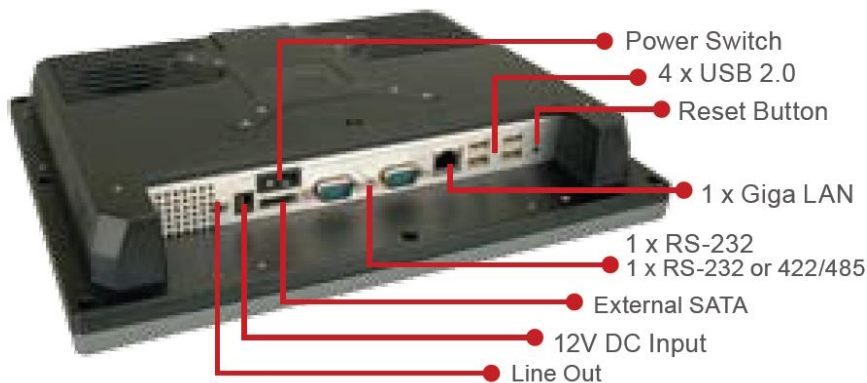

Fig. 3-2: Panel PC connections [Afolux]

### 3.2.3 Electrical equipment

- **Low voltage cable:** as the one shown on Fig. 3-3 [72].



Fig. 3-3: Low voltage cable [TopCable]

- **Switchboard:**
  - o It must enable switching and signalling.
  - o Installation and location: in the kitchen, embedded in the partition wall K-1, behind the entrance door, over the DDC panels, at a height  $H = 1.7$  m.
- **Lighting fixtures:**
  - o Conventional fluorescent strip lights. 2 strips per room in the technical ceiling, at 45 degrees with respect to the fan-coil units.
  - o Ballasts:
    - For the control of the lights, it was considered to use a dimmer [73], but this is not suitable for fluorescent lighting. Hence, the necessity of fitting compatible electronic ballasts [74].

- Ballasts are given a 0÷10V signal from Lonix modules, so there needs to be 2 wires from each one of the LON modules to their corresponding ballast<sup>69</sup>.
- o Switches:
  - A normal light switch with one button (just a lever for selecting between manual and automatic). It is used for enabling the automatic lux level control in the room.
  - A second switch with an internal spring mechanism allowing for what is called “momentary” operation: when one pushes it, the circuit is closed, and after that, the spring opens it again (so it is a Normally Open circuit). The intensity level is given as a function of the time lapse that the switch is pressed.
- o Fig. 3-4 shows in a schematic way how the lights are switched on and off, how the intensity level is selected, and if these operations are done manually or automatically. There will be 2 switches per room, one for choosing between manual or automatic operation, and another one for switching the light on/off when it is in the manual position, and manual dimming.

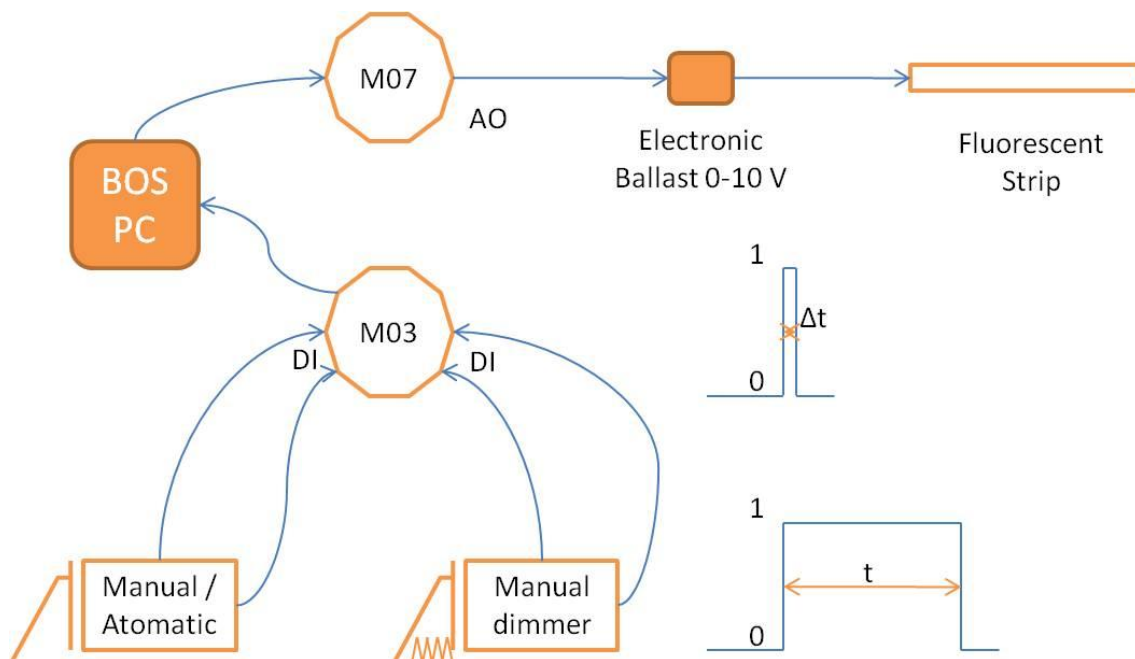

Fig. 3-4: Lighting control system [DRA]

- **Uninterruptible Power Supply (UPS)**<sup>70</sup>. Requirements:
  - o On-battery runtime: It must be sufficient to allow time to bring an auxiliary power source on line, or to properly shut down the protected equipment.
  - o VA rating, Location & installation, etc<sup>71</sup>.

<sup>69</sup> If the ballasts used field supply (typically 24 Vdc), then there should be 4 wires, but these are loop-powered devices (2 wires are enough).

<sup>70</sup> An Uninterruptible Power Supply is an electrical apparatus that provides emergency power to a load when the input power source, typically the utility mains, fails. A UPS differs from an emergency power system or standby generator in that it will provide near-instantaneous protection from input power interruptions by means of one or more attached batteries and associated electronic circuitry for low power users. While not limited to protecting any particular type of equipment, a UPS is typically used to protect computers and avoid data loss. Besides, they improve the quality of the electricity since it filters out the voltage peaks and remove the harmonics in alternating current.

<sup>71</sup> Not specified. Note that the UPS was not finally installed for budgetary reasons.

### 3.2.4 Metering devices

It was decided to use the same equipment than at Margaritas Building (I3CON's real building demonstrator).

They are connected to the LON modules by means of cables pulled from the DDC panel<sup>72</sup>.

- **Water (hot & cold) meter:**
  - o The Istameter pulse counter model 19404 [75] is equipped with a transducer disk through which the readings are transferred to the BOS<sup>73</sup>.
  - o Installation is done in series with the water pipes, fitted into a single pipe connector housing, as shown on *Fig. 3-5*.
  - o Location:
    - Hot water meter: discharge line (pipe running water towards the washbasin tap).
    - Cold water meter: general water supply inlet (in the kitchen).



*Fig. 3-5: Water meter installed in the Mock-up pipes [DRA]*

- **Electricity meter:**
  - o Digital single-phase direct meter [76].
  - o Connectivity: KLMA cable (or similar) pulled to LON module.
  - o Installation and location: wired from the switchboard to the Counter-module of the DDC panel, terminals 15/17.
- **Caloric energy meter:**
  - o The metering device [77] receives volume pulses from the connected flow meters and calculates the energy for every predetermined water volume<sup>74</sup>.

---

<sup>72</sup> Meter readings could also be read via a communications network – either Ethernet based or WSN based. In a multi-housing environment, it would be interesting to connect all the metering devices through a communications bus (e.g. M-Bus), but in the Mock-up this is not necessary given the small number of devices.

<sup>73</sup> The output module provides remote communication of consumption data in the form of potential-free pulses using a variety of pulse values, in this case 1 litre per pulse.

<sup>74</sup> The energy calculation includes temperature measurements in flow and return as well as correction for density and heat content according to EN 1434.

- o A LON-module [78] is used to transmit data from the calorie meters by means of a LON-network.
- o Connectivity: the cables between the LON-module and the LON-nodes are standard twisted pair cables.
- o Installation [79] and location: at each one of the fan-coil units (one per room), fitted in series with the bypass pipes of the FCUs.



## 3.3 Wired Sensors

### 3.3.1 Outdoor sensors

- **Outdoor Temperature and Humidity Transducer [80]:**
  - o Dry-bulb temperature sensor.
  - o Relative humidity degree sensor.
  - o Location: behind the roof parapet of façade panel P-03.
- **Outside illuminance / solar radiation sensor (pyranometer) [81]:**
  - o Necessary to measure and control glare.
  - o Power supply: 14-30 Vdc.
  - o Connectivity: the output must be a 0÷10 Vdc or 0/4÷20 mA signal. It is made by means of a cable which has 4 pins in one side (to be connected to the pyranometer), and four spare wires at the other side: two of them are for power supply and the other two are for the output voltage (0÷10 V).
    - This voltage signal is the input for the BOS. To be connected to module M18, terminals 23/24.
  - o Installation: mounted with the sensor surface in the plane of the panel. Nothing has to hide the sensor (the cornice, a gutter or something else).
  - o Location: it must be near the glazing on the outside panel, being the best position<sup>75</sup> outside the glass on top of the window of P-02.
- Wind speed/direction: they are not necessary for measuring the performance of the components installed in the Mock-up.
- **Note:** These sensors are used as alternative to the Outdoor Weather Station suggested in first place by TRT (see § 6.2.3).

### 3.3.2 Sensors deployed at the façade panels

The ambient and surface temperature sensors to be deployed are Pt-1000 (being Pt-100 not compatible with LON) 1/3 DIN B resistance thermometers<sup>76</sup>.

The variation of the electric resistance due to the  $\Delta T$  originates an analog 4÷20 mA signal, which is used as input by the control system. This signal is standard and compatible with LonWorks. For the measurements, a Wheatstone bridge is deployed. The four-wire resistance thermometer configuration (2-wire and 3-wire are also possible) increases the accuracy and reliability of the resistance being measured<sup>77</sup>.

---

<sup>75</sup> If this is not possible, one solution would be to put it directly on the roof. But then, a part of the sensor should be hidden to avoid that too many light from every direction come in the sensor (the mask has to select a light direction).

<sup>76</sup> The DIN Standard recognizes three different tolerance classes:

- DIN Class A tolerance:  $\pm[0.15 + 0.002 \cdot |t|]$  °C
- DIN Class B tolerance:  $\pm[0.30 + 0.005 \cdot |t|]$  °C
- DIN Class C tolerance:  $\pm[1.20 + 0.005 \cdot |t|]$  °C

1/3 DIN B means that tolerance is  $\Delta T = \pm 1/3 \times [0.30 + 0.005 \cdot |t|]$  °C. This yields  $\Delta T = \pm 0.13$  °C at 20 °C, which is enough for the kind of measurements that are going to be carried out. Note that choosing tolerance 1/10 DIN B, so that  $\Delta T = \pm 0.04$  °C at 20 °C, would mean increasing the cost from 25 € to 50 € per sensor approximately.

<sup>77</sup> In four-wire measurements, the resistance error due to lead wire resistance is zero. Furthermore, the four-wire Kelvin connection provides full cancellation of spurious effects and cable resistance of up to 15  $\Omega$  can be handled.

A voltage source is required: the same wires used for the signal transmission are used for supply electricity to the bridge. Due to the location (outdoors) and the watering, these sensors must be encapsulated in a plastic case and sealed. Their position was shown on *Fig. 2-17*.

These sensors were customized to this project by the Spanish branch of TC Measurement & Control Inc<sup>78</sup>, so there are no published datasheets; their characteristics are detailed in the following epigraphs (in brackets, the number of the necessary units of each sensor).

- **Ambient temperature (AT) sensors (x9)**
  - o Pt-1000 class B probe terminated in a pot seal.
    - Stainless steel sheath 3x100mm.
  - o 4 wire configuration.
  - o Cable: 10 m long insulated with Teflon.
  - o Power supply and connectivity: the same wires used for the signal transmission are used for supply electricity to the bridge.
  - o Installation and location: *see figures throughout § 2.2.4*.
  - o Note: the caption of *Fig. 3-6* says Pt-100; the reason for using a Pt-1000 element is because Pt-100 is not compatible with LON system.

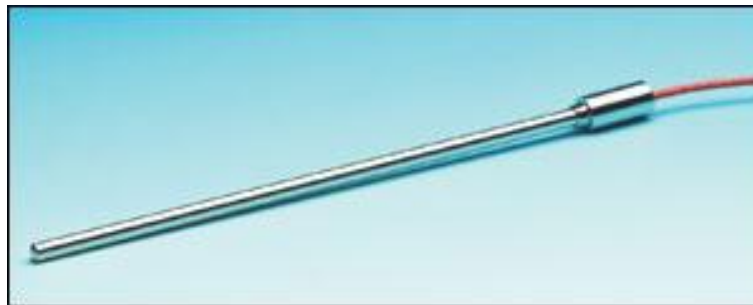

*Fig. 3-6: RTD sensor Pt-100 with pot seal [TC]*

- **Surface temperature (ST) sensors (x14)**
  - o Pt-1000 class B thin film element encapsulated in a rubber patch.
    - Self-adhesive silicone: 30mm x 14mm x 3.4mm
  - o 4 wire configuration.
  - o Cable: 15 m long insulated with Teflon.
  - o Power supply and connectivity: the same wires used for the signal transmission are used for supply electricity to the bridge.
  - o Installation and location: stuck to the innermost side of the façades P-02 and P-10 wallboards, at an intermediate height between the floor and the window sill (2 units together at each panel, one serving as a back-up of the other one).
  - o Note: They are physically the same than the sensor shown on *Fig. 3-7* but, as before, it will feature Pt-1000 instead of Pt-100.



*Fig. 3-7: RTD sensor Pt-100 with self-adhesive patch [TC]*

<sup>78</sup> [www.tc-sa.es](http://www.tc-sa.es)

- **Relative Humidity (RH) sensors (x4)**
  - o Passive transmitter Deltaohm HD 2007TC/1 measuring in a range 5÷98 % RH [82].
  - o Dimensions (*Fig. 3-8*):
    - The transmitter is housed in a sturdy polycarbonate box 80x120x55 mm (HxWxD) rated to IP67<sup>79</sup>.
    - The sensor is a 14 mm (diameter), 130 mm long probe connected to the instrument by means of a 1.5 m long wire.
  - o Power supply: 7÷30 Vdc.
  - o Connectivity: 2-wire, 4÷20 mA output (4mA = 0% RH, 20mA = 100% RH).
  - o Installation<sup>80</sup>: For 4÷20 mA sensors there needs to be a 500 Ω resistor (*Fig. 3-9*). The example on *Fig. 3-10* corresponds to AO[0], terminals 19/20 of a 2242P4 module. The same applies for all analog inputs used with 4÷20 mA signals.
  - o Location:
    - The junction box is located inside the Mock-up, wall-mounted.
    - The probe measures the RH degree outside.
    - The wires are pulled through the joint between the façade panel and the floor, making use of sealed feed-through assemblies.

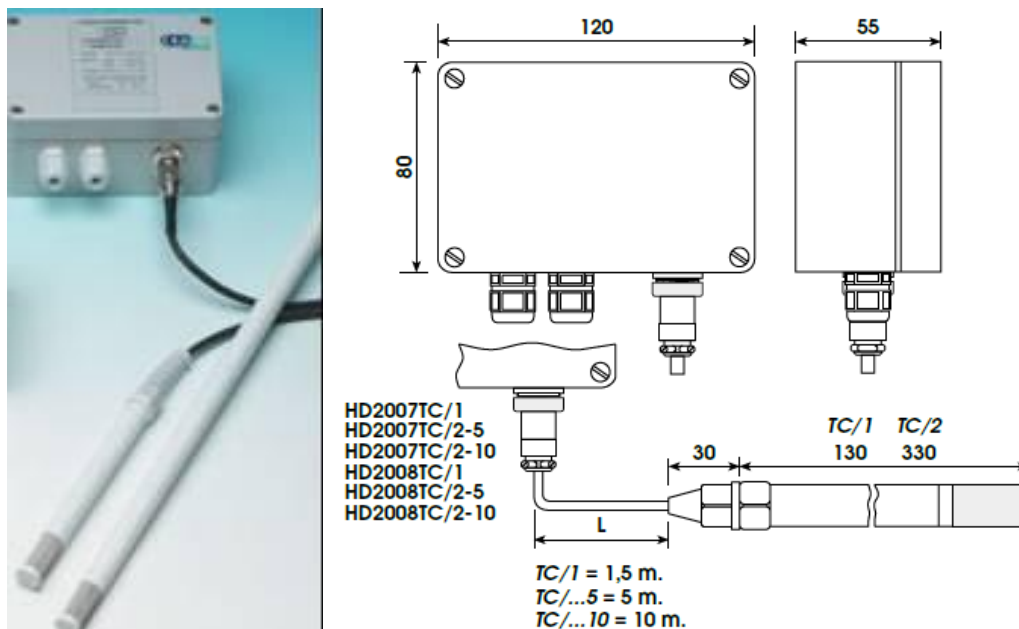

*Fig. 3-8: RH sensor probe installed at the vegetated panels. The transmitter is housed in a remote box, wall-mounted. Probes and wires of different lengths are available [TC / Deltaohm]*

<sup>79</sup> Protection Class for electronic equipment and their enclosures is given by the two code letters IP (Ingress Protection) followed by a two-digit number rating the protection against the ingress of solid objects (first digit) and liquids (second digit), according to EN-60529 and the International Electro-Technical Commission. IP67 means: Totally protected against dust ingress; Protected against short periods of immersion in water.

<sup>80</sup> It only has two connecting pins, but in the wiring diagrams of the Appendix V (M07-AI[2]-P04 Humidity-1) there are three signals (+24V, Y 24 and G0 23). This type of three-wire connection appears more than once.

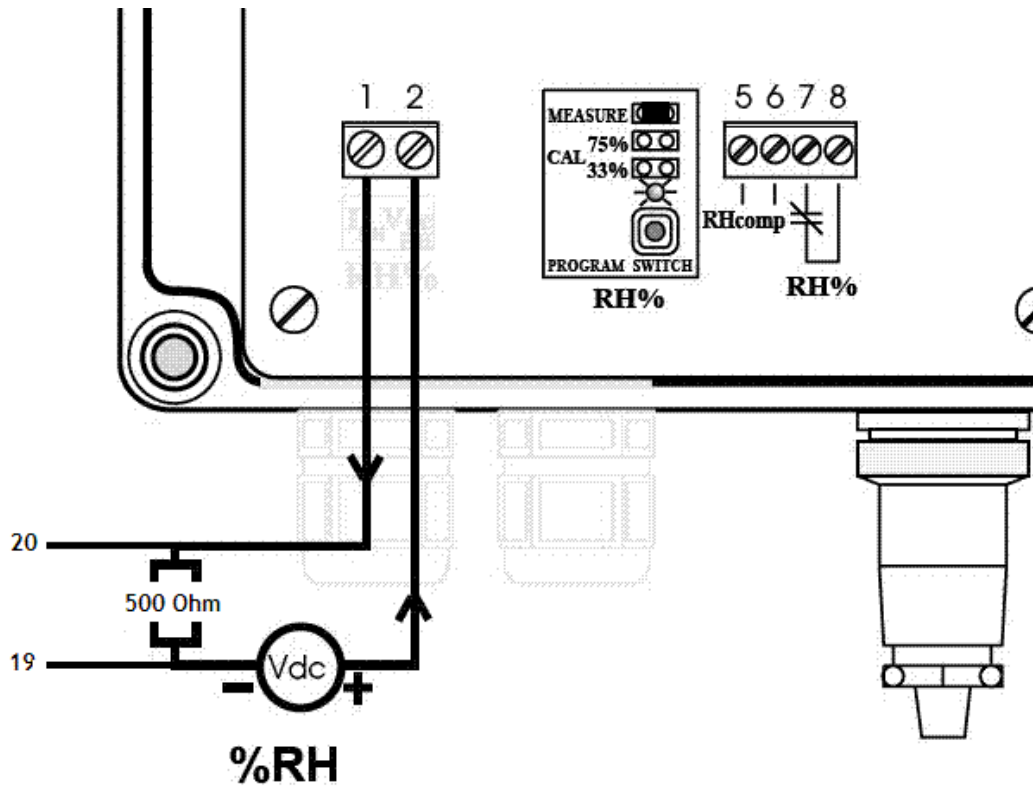

Fig. 3-9: Control wiring to RH sensor [LON]

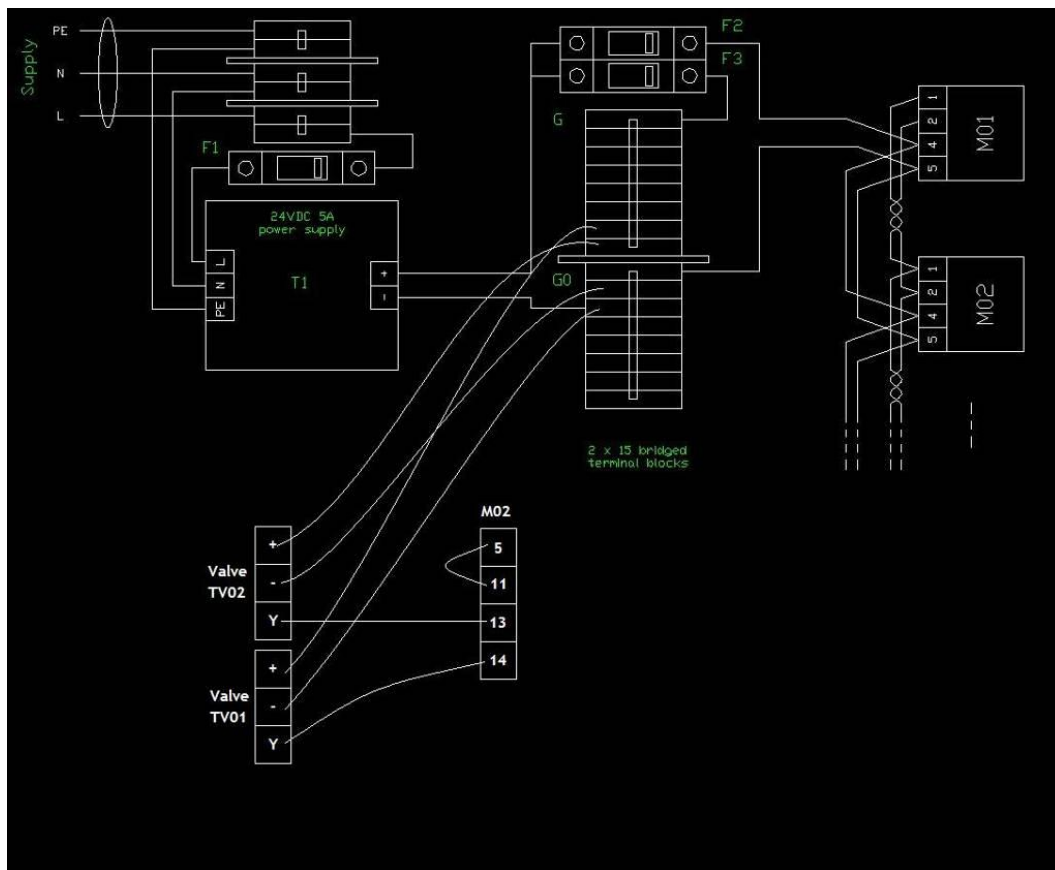

Fig. 3-10: Schematic of the wiring connections [LON]

### 3.3.3 Wired indoor sensors

- **Presence:**
  - o There are wired passive infra-red (PIR) sensors in all the rooms [83]:
    - Rooms Local-1, Local-2 & Local-3: in order to control the ECGU.
    - Kitchen & Bathroom: in order to trigger the re-circulation pump (water saving system).
  - o Installation & Location<sup>81</sup>:
    - In the technical ceiling of each room.
    - At a height of 2.4 meters, the occupancy sensors cover a circular area with a diameter of approximately 7 meters so it shouldn't matter if the sensors are not installed exactly at the centre of the room.
- **Indoor ambient temperature:**
  - o The temperature and illuminance sensors of the WSN collect data every 15 minutes, which seems to be quite a long period for an adequate control of the indoors environment (the frequency could be increased but then the batteries of the HLT sensors would run out). Therefore, there will be a wired indoor ambient temperature sensor per room [84].
  - o Installation & Location<sup>82</sup>: at a height  $H = 1.7$  m, in the middle of the partition walls, next to the door on either side of the room.
  - o Note: A room temperature transducer equipped with a potentiometer for local set-point adjustment of occupied spaces and LCD display for monitoring the current room temperature are usually employed in conventional installations, but in the Mock-up these functions are integrated within the BOS and the PC panel.

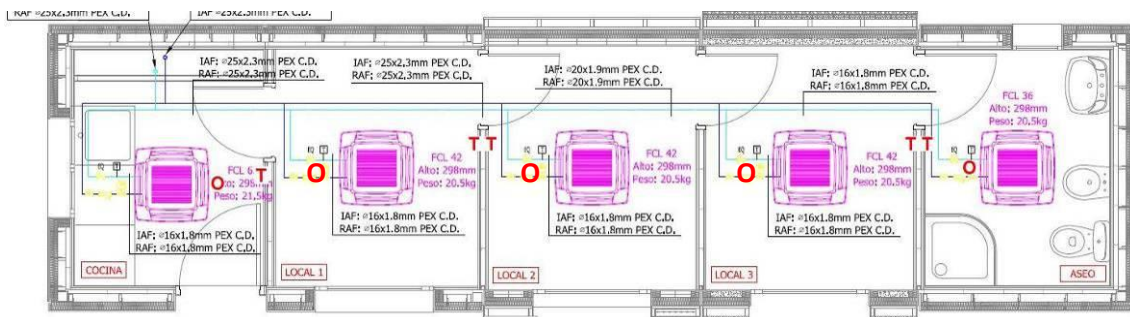

Fig. 3-11: Position of the wired, indoor temperature (T) and occupancy (O) sensors [LON]

- **Light:**
  - o For the environment control of the Mock-up, the light sensors from the WSN (see § 3.4.2) are going to be used first, but cables are pulled for additional (wired) lux transducers, so that it would be easy to add them if needed<sup>83</sup>.
- Heat flux sensor between the rooms: it is estimated that, given the precision level of the measurements sought, this is not necessary.

<sup>81</sup> The “vision” of these sensors is based on infra-red technology which detects body heat, so it must not be distorted by the air stream coming from the fan-coil units.

<sup>82</sup> It is interesting to measure the temperature at the average head height in order to evaluate comfort.

<sup>83</sup> The most likely problem would be regarding the measuring frequency of the wireless sensors (max 1/min).

### 3.3.4 Water temperature and flow

- **Flow switch (Fig. 3-12):**
  - o Installation: The flow switch can be mounted on pipes with diameters from 1 to 8 inches; the outlet pipe of the heat pump is 1¼ inch. It can be mounted in every position (best upright) far from elbows or narrowing, arrow must be oriented downstream. If pipe is vertical, just reset the range to balance paddle weight. It is needed a T joint that fits the flow switch and the pipe. The shortest (1 inch) paddle is attached to the switch.
- **Water temperature**
  - o Associated systems/equipment: solar thermal collector, heat pump, under-floor heating, hot water recirculation system<sup>84</sup>, and HVAC<sup>85</sup>.
  - o 14 platinum resistance thermometers Pt-1000 [84] (Fig. 3-13).
  - o Installation: strapped on the pipes by means of an adjustable tie. In principle, the cables are 2 m long, but more cable can be spliced.
    - If this splicing distorted the measurement, the error could be offset with the LON modules.
  - o Location: metallic joints of the PEX pipes, which are laid on the plasterboard sheeting of the façade panel P-11.

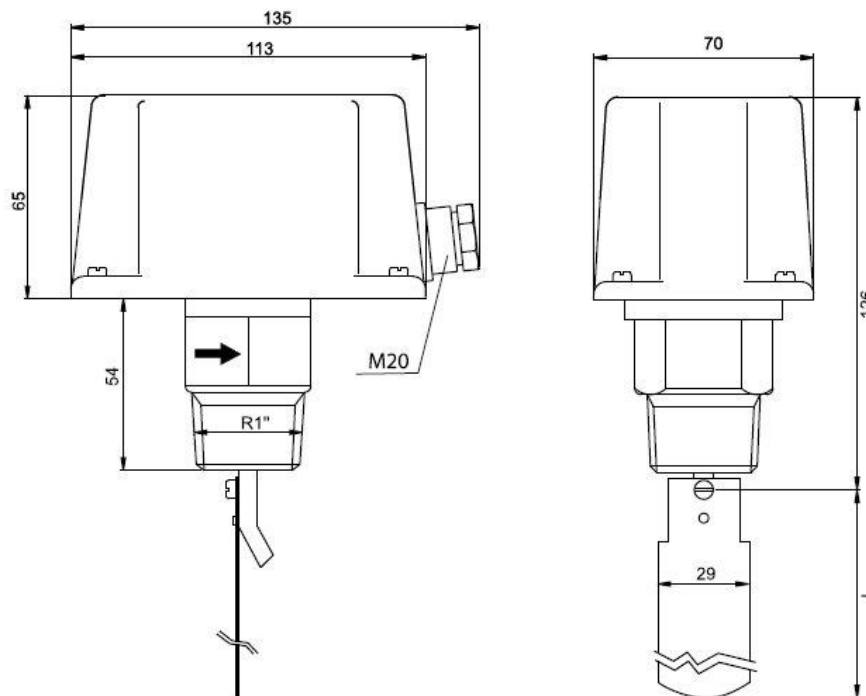

Fig. 3-12: Flow switch [LON]

<sup>84</sup> The pump of the water saving system begins to re-circulate the water in the pipes whenever the presence sensor is triggered or the water temperature in the pipes is lower than a given value (47 °C because of *legionella*).

<sup>85</sup> The original installation Project intended to measure the consumption of each FCU by means of thermometer probes and flow meters fitted in the pipes of the fan-coil units (as it is indicated in the installation drawings), but in the end the measurement will be done by calorie-meters that already include readings of  $\Delta T$  y  $\Delta Q$ .





*Fig. 3-13: Resistance thermometers TEPK Pt-1000 [Produal]*

## 3.4 Wireless Sensor Network

TRT plans the following Wireless Sensor Network (WSN) configuration deployment:

- Fully functional WSN framework [85] (tiny wireless measurement system for deeply embedded sensor networks, high data rate and radio wireless communications with “every node as router” capability) that senses phenomena (relative humidity, light, temperature, CO<sub>2</sub> concentration, presence and others –barometric pressure, wind speed and direction, acceleration/seismic, acoustic, etc.) and stores the readings in a local database.
- The wireless sensors installed in the Mock-up (kitchen, bathroom, and test rooms Local-1, Local-2 and Local-3) are:
  - CO<sub>2</sub> & Presence (C&P), *see § 3.4.1.*
  - Humidity, Light & Temperature (HLT), *see § 3.4.2.*
- WSN framework allows other partners to access data through Ethernet network (wired or wireless) or the Internet, both using REST-based<sup>86</sup> Web Services [86].
- WSN can be tasked or re-tasked (for example for higher sampling rates) if necessary. This feature will be access-controlled. Note that this would affect battery life.

### 3.4.1 C&P: CO<sub>2</sub> & Presence

- CO<sub>2</sub>: pre-calibrated module, low-power consumption solid electrolyte sensor [87] & [88].
- Presence: pyroelectric Passive Infra-Red (PIR) sensor [89].
- Power supply: the whole package is powered by a standard 9 Vdc power supply. Provisions should be made for the cabling of this power supply to a nearby socket.
- Connectivity: sensors are connected to the Crossbow MICAz Processor & Radio Platform (MPR2400CA) for data processing and communications [90] & [91].
- Installation and location:
  - Crossbow MDA300CA [92] is used as a prototyping board for the C&P set<sup>87</sup>. It is mounted within a flame retardant ABS plastic enclosure with flange lid [93] (*Fig. 3-14 and Fig. 3-15*).
  - The assembly weighs less than 1 kg. The enclosure is secured by its flange, either slotted into a correctly sized cavity, or surface mounted (*Fig. 3-16*).
  - Provision should be made for the power plug/socket on the enclosure if slotting into the wall cavity, as pipes or structures in the cavity may impede it.
  - Location<sup>88</sup>: mounted either in the middle of the eastern partition wall of each room at H = 2.4 m, or in the technical ceiling.
- Guarantees:
  - CO<sub>2</sub> sensor – 1 year warranty. However, these sensors are very sensitive and they could die during development or deployment, so the Bill of Materials (BoM) includes two extra ones for contingency plan if any dies.
  - PIR sensor – not verified.
  - Crossbow hardware – 1 year warranty.

---

<sup>86</sup> Representational State Transfer (REST) is a SW architecture for distributed hypermedia systems.

<sup>87</sup> There is no sensor mote with embedded CO<sub>2</sub> and Presence sensors available from Crossbow.

<sup>88</sup> PIR sensors “look” for body heat. Their “vision” must not be distorted by the draught coming from the fan-coil units. If that happened, the sensors should be relocated.

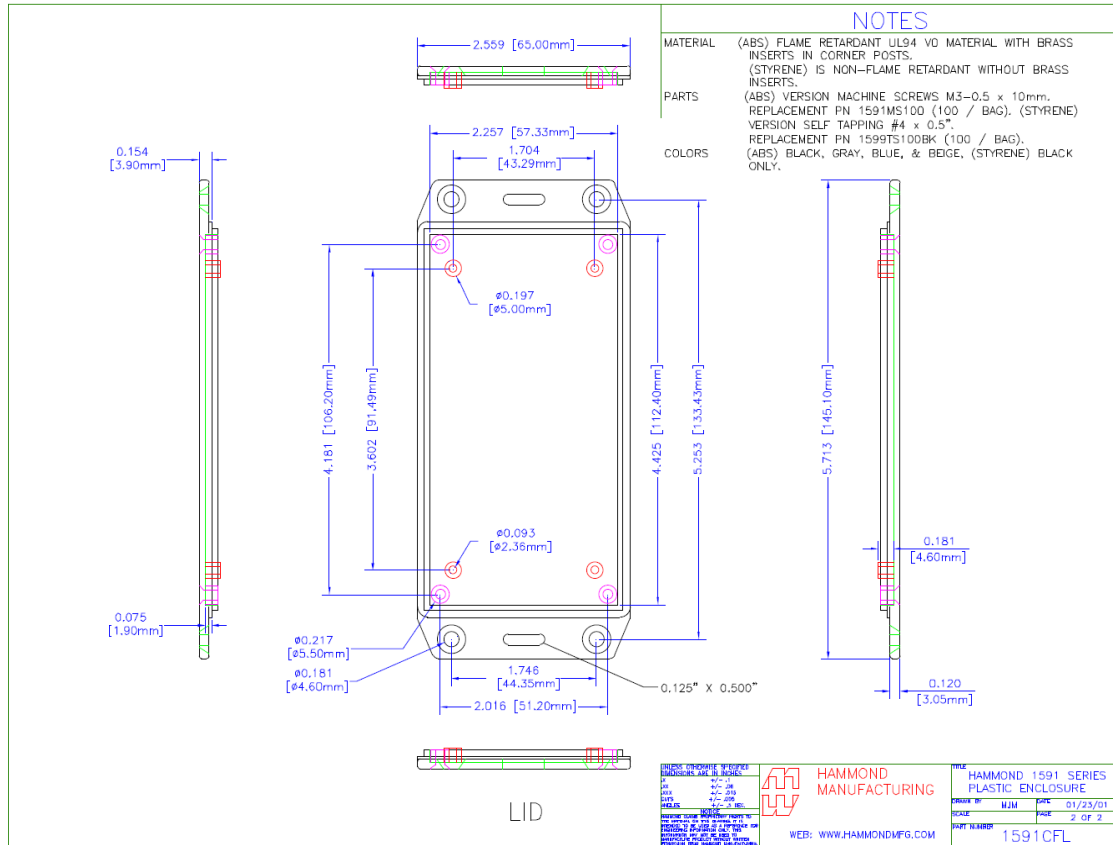

Fig. 3-14: C&P Sensor front view [Hammond]

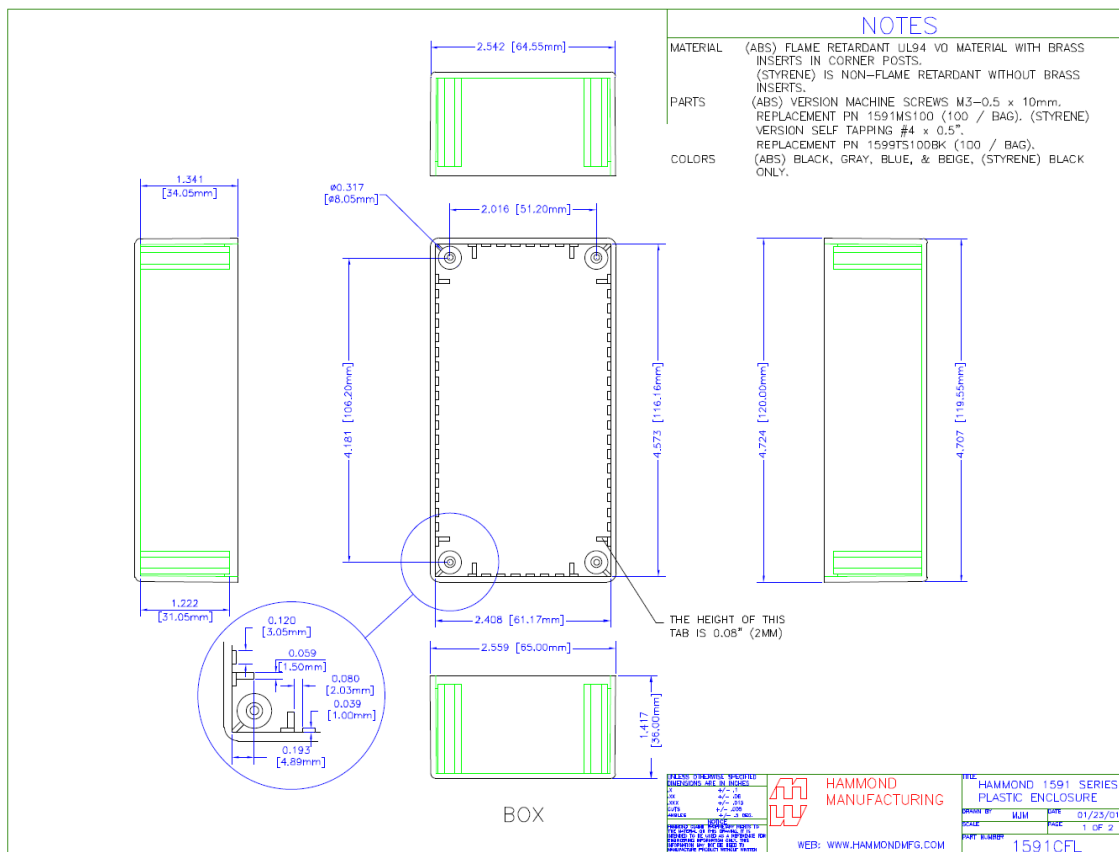

Fig. 3-15: C&P Sensor rear view [Hammond]

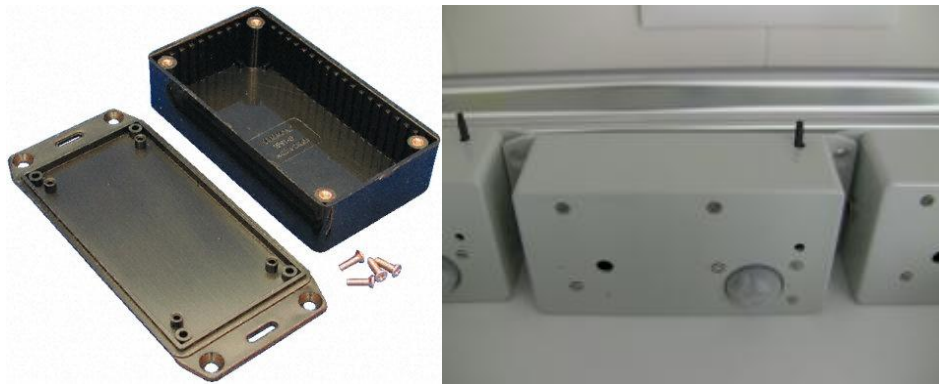

Fig. 3-16: Left, an un-constructed housing unit for the CO<sub>2</sub> and Presence sensors; Right, once assembled and fitted [TRT]

### 3.4.2 HLT: Humidity, Light & Temperature

- Crossbow MTS400CB sensor board [94].
  - o Ambient Light sensor: Taos TSL2550D [95].
    - Spectral response: 400÷1000 nm (similar to human eye).
  - o Relative Humidity & Temperature Sensor: Sensirion SHT11 [96].
    - Humidity range; resolution: 0÷100% RH; 0.03% RH.
    - Absolute RH accuracy: ± 3.5% RH.
    - Temp. accuracy: ± 0.5 °C at 25 °C.
- Housing: Crossbow MIH2400CA enclosure (Fig. 3-17):
  - o Black section: 63 x 36 x 20 mm.
  - o Transparent section: 63 x 36 x 23 mm.
  - o Weight: less than 0.5 kg.
- Power supply: provided by 2 AA batteries, which lasts 2–3 months for the standard sensor data collection every 15 minutes.
- Connectivity: sensors are connected to the Crossbow MICAz Processor & Radio Platform (MPR2400CA) for data processing and communications [90] & [91].
- Installation and location:
  - o The unit is mounted using a single screw to the underside of the unit. This allows easy access to battery compartment and mount/dismount of the set.
  - o HLT units are placed indoors, in strategic locations to be decided prior to installation, e.g. next to the C&P sets at H = 1.7 m in the middle of the partition walls. Since this sensors are wireless, they can be easily relocated.
- Guarantees: Crossbow's hardware – 1 year warranty



Fig. 3-17: Left, Xbow enclosure for HLT sensors; Right, WSN Base Station [Xbow / TRT]

### 3.4.3 Base station

- Converts radio messages from sensors' transmissions to IP-based messages, and transmits these through the MICAz Ethernet Interface MIB600CA [97].
- Housing: injection-moulded enclosure Crossbow MBH600CA (*Fig. 3-17, right*). Dimensions: 12.5x4x8 cm (not including antenna).
- Power supply: permanent 5 Vdc, to be provided either by a DC power supply or via a suitable PoE<sup>89</sup> connection.
- Connectivity:
  - o Via radio with the sensors.
  - o IP connection from base station to gateway (see § 3.4.4 ), nominally through Ethernet.
- Installation and location:
  - o Provisions must be made for Ethernet (coaxial, twisted pair, or optic fibre –RS 232) and power cables when mounting the unit.
  - o Consideration must be made for antenna as well, as it will probably need to be extended for good radio reception/transmission.
  - o Location: on a shelf (the enclosure is not prepared for being hooked to the wall) at H = 1.5 m (Local-2).

### 3.4.4 Gateway and web server

- Web application and WSN application software to be run on a standard personal computer (PC) which may require a display monitor for demonstration and general maintenance.
- Power supply: Uninterrupted mains power supply desirable.
- Connectivity:
  - o IP connection to WSN base station(s) via Ethernet.
  - o Internet connectivity for access to data, general maintenance and upgrades.
- Installation and location: in the kitchen, at the installer's prerogative, as long as connectivity requirements and power supply are met.
- Integration: any HTTP-compatible application (such as a web browser) can access the sensor data and display it. The interface with the BOS has been resolved. *See also §§ 3.4.5 & 3.5.*

### 3.4.5 Operation of the WSN

- **Battery life** should be carefully managed in every sensor network deployment in order to make sensors perform in a more efficient way. Hence, maintenance activity will be every few months, with possible battery changes every 2-3 months. The remaining battery power of the nodes is monitored automatically, but will need the judgment of an operator on when to replace the batteries.
  - o Health monitoring software provides information about remaining battery power and quality of WSN radio links. This application is accessible remotely and will be used for maintenance purposes<sup>90</sup>.

---

<sup>89</sup> Power over Ethernet (PoE) is a technology that allows power supply over the communications Ethernet cable, making electrical switches unnecessary. Besides, it facilitates the application of Uninterrupted Power Supply (UPS) systems for a 24/7 functioning.

- **Integration** of the WSN and other sensors/metering equipment within the BOS (*see also § 3.5 & 3.6*):
  - o The WSN in itself proves the concept of I3CON open building services architecture. Specifically, the fact that the pump of the water saving system begins to re-circulate the water in response to WSN system's presence sensor and wired strap-on temperature sensor (controlled by the Mock-up BOS) demonstrates that the integration of different systems is possible.
  - o Access to network data from the control system: data from WSN and other measurements are compiled on a PC application and displayed on the screen (only raw data, although stating that if the Mock-up was dwelled these data could be use for devising more advanced Performance Metrics). The Mock-up BOS provides BIM data (e.g. Mock-up CAD Drawings, stored on a server) and access/control to WSN data, information back-up and remote monitoring of the operational status of the server.
  - o Integration of ICOM's Rule Based Engine with TRT's WSN infrastructure and access to the data from Mobile Productivity Tools (MPTs) is done through an open web services interface and from a PDA.

---

<sup>90</sup> The management of the building must be aware of the variety of sensors included in the building in order to pinpoint and correct possible inconsistencies and also to take advantage of more accurate and correlated performing thanks to their combined utilisation.

### 3.5 ICT requirements for remote access & control

Internet connection is very important for the measurement plans. It allows remote collection of data and access for its processing by the partners involved in the Mock-up monitoring & control.

An ADSL line has been subscribed<sup>91</sup> with a static IP address (79.148.124.213) so that I3CON partners Dragados (DRA), Intracom (ICOM), Lonix (LON) and Thales (TRT) can connect remotely.

- The following ICT equipment has been installed in the Mock-up:
  - o Panel PC for the LON software and user interface (see § 3.2.2).
  - o This panel PC is not enough for running also ICOM and TRT respective software programs; therefore, it is necessary, either three different PCs (Fig. 3-18), or a more powerful server to be virtualised as three different machines (ICOM, LON & TRT) running their corresponding SW (Fig. 3-19).
  - o Router to network PCs, meters, sensors and actuators over Ethernet.
  - o In order to have a single server with three different virtualised machines, it was decided to go with VMWare<sup>92</sup>; hence, the physical machine must have BIOS supporting “hardware virtualisation” for VMWare to work efficiently.
  - o Hardware requirements (memory, processor, etc.) are specified on Table 3-3.
  - o Software requirements are specified on Table 3-4.
  - o The machine was prepared by DRA in Madrid and then delivered to SEIS’ factory in Seville. Partners’ software programs were delivered either remotely, once the machine was setup in Seville, or installed on site when partners visited the Mock-up.

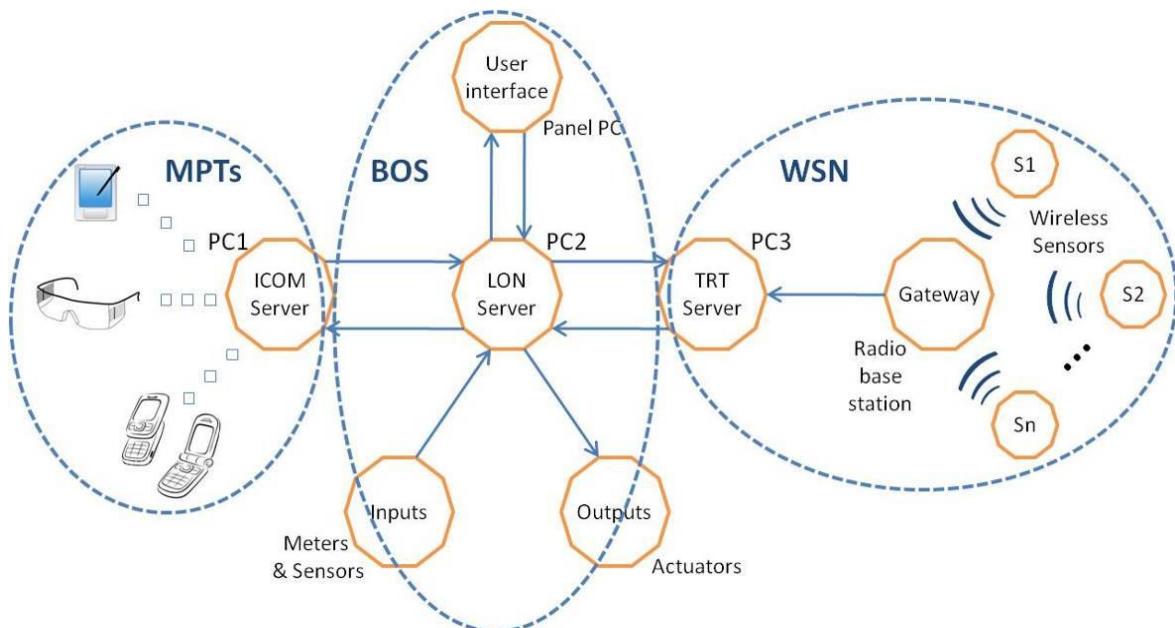

Fig. 3-18: Mobile Productivity Tools, Building Operating System, and Wireless Sensor Network server configuration with three different PCs [DRA]

<sup>91</sup> After meetings with Dragados’ and SEIS’ ICT Departments, it was decided to subscribe an ADSL line with Telefónica operative from May 2010 onwards. The decision of not using SEIS’ network was taken to give more freedom to the location of the Mock-up within the yard of the factory.

<sup>92</sup> VMWare ESXi 4.0 is free (subject to registration); [www.vmware.com](http://www.vmware.com)



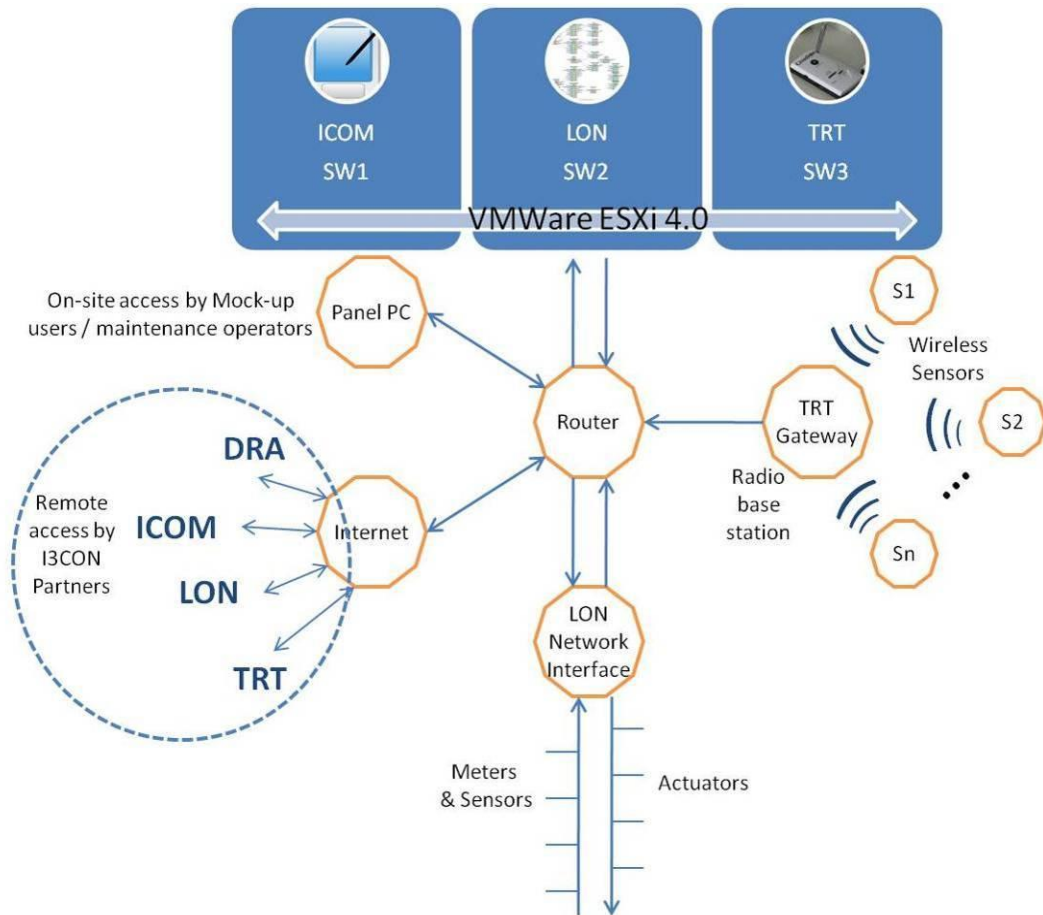

Fig. 3-19: MPTs, BOS, and WSN with their respective software (developed respectively by ICOM, LON, and TRT) running on virtual machines over a single server PC [DRA]

Table 3-3: HW specs [DRA-ICOM-LON-TRT]

Server PC <sup>93</sup>	BIOS supporting “hardware virtualisation”.
	A minimum of 4GB of RAM for each virtual machine (total recommended 16GB RAM).
	Multiple-processor motherboard (not just multiple core processors).
	UPS offering between 5 and 10 minutes of power autonomy (PC + monitor) for a safe shutdown (Dual power supply case is also suggested).
	Enough hard disk capacity to install all the operating systems, development tools and application software needed as well as virtual memory space, system cache, etc.
	A standard number of I/O ports (USB, Ethernet, etc.).
	Flat monitor 19 inches or above (to show project information and/or videos).
Router and/or gateway and firewall to:	Connect the 2 computers (Server and panel PC) in the Mock-up. The panel PC is provided by Lonix and runs the control system interface.
	Connect laptops to the Mock-up network for development purposes.
	Connect to the Internet or accept connection from the Internet (e.g. queries to the web servers).

<sup>93</sup> Summary: Dual 2.8GHz processor server motherboard, 16GB RAM, dual power supply, 3x100/1000Mbps Ethernet (RJ45), 2xRS232 (9-pin/25-pin), parallel port, 6xUSB2, WiFi 802.11a/b/g/n, DVD-RW, graphics card supporting 1280x1024 resolution or higher.

Table 3-4: SW specs [DRA-ICOM-LON-TRT]

Server machine in the Mock-up	On top of HW	VMWare ESXi 4.0 (bare metal hypervisor).
	Virtual Machine 1 - ICOM	WinXP-SP2 or any Vista OS (do not install a server OS like Windows Server 2008, it makes development more complex.)
		Microsoft Visual Studio 2008 (Visual Studio 2008 to be installed with Web Development and C#/C++ support, no Visual Basic required).
		Internet Information Server IIS7 (ports: TCP 80 HTTP, TCP 443 SSL if needed).
		A static IP is needed for ICOM virtual server.
		Access to external web pages to be possible from the virtual server.
	Virtual Machine 2 - LON	WinXP-SP2 or any Vista OS (do not install a server OS like Windows Server 2008 it makes development more complex.)
		Apache Tomcat web server 6.0.26 (Servlet 2.5 and JSP 2.1 specifications). Ports: TCP 8080, TCP 8443 SSL if needed.
	Virtual Machine 3 - TRT	WinXP-SP2 or any Vista OS (do not install a server OS like Windows Server 2008 it makes development more complex.)
		Apache HTTP Server.
		Apache Tomcat web server 6.0.26 (Servlet 2.5 and JSP 2.1 specifications). Port for serving the Flash application: TCP 8080 (nominally), or TCP 8443 SSL (if needed). Finally remote desktop (probably a different port than LON/ICOM).
		MySQL (version 5 or above).
		Java Development Kit (latest release. Last one from Sun is JDK 6 Update 20)
		Flash support for the browser. Just run up IE or Firefox once Windows is installed, and install Flash player from Adobe.
	Internet access	LON: static public IP address for the server and ports 3030-3050 (COBA BOS) and 3390 (Remote Desktop) to be opened for communication.
Web servers of the virtual machines need to be accessible from the outside (e.g. remote web service requests).		
Clients connected to the wireless Access Point need access to all virtual servers (ICOM, LON & TRT) and external (public) web pages.		
Administrator rights	The related partners (ICOM, LON & TRT) need administrator rights in this computer to manage the machine.	
	Remote access for installation of SW in advance to their travel to Spain is highly recommended.	
	The number of administrator users in every logical machine will be two.	
	Number of concurrent logins with Administrator rights will be limited to two per logical machines in order to preserve the Internet connection bandwidth.	
	Number of concurrent HTTP sessions opened against the logical machines will be limited to 10.	
PC at Dragados' headquarters (Madrid)	COBA UI Client applications installed in computers in Madrid for remote monitoring of the Mock-up. It is a Java application so it is necessary to have installed the latest Java Runtime Engine (JRE).	

## 3.6 Mobile Productivity Tools

### 3.6.1 Objectives and planned demonstration activities

Each one of the elements controlled by the Mock-up BOS has a micro RFID tag attached to allow the component to be recognised by Mobile Productivity Tools (MPTs), for example a Personal Digital Assistant (PDA). These terminals incorporate technology developed by ICOM within I3CON Project that allows context-aware action to be taken, e.g. in the simplest case, to identify specific equipment and pull relevant information (schematic, location on a map, state, sensor measurements, or any other reading from the BOS) about this element<sup>94</sup>.

- **Capabilities [98]:**
  - o Positioning via RFID and localization of RFID tagged sensors as one of the features of the multi-modal User Interface (UI) plus various usability features (use of touch screen, speech interface, RFID, etc.).
  - o It will be used location and context awareness in the UI, supplemented with ASR/TTS voice interface and free-space mouse-like manipulation.
  - o Image will be provided either via see-through monocular and directly on the touch screen of the PDA.
  - o Automatic display of active area maps (manually also maps of other areas) with any relevant sensor information.
  - o Location-awareness (user and sensor positions), context-awareness (operating mode), information-awareness (sensor data related), etc.
  - o Terminal adaptation: in terms of terminal capabilities (networking, RFID reading, screen, buttons available, sound capabilities, etc.)<sup>95</sup>.
- Specific information required to configure the services within the MPTs (*see Table 3-2*):
  - o Information about all Mock-up components that will be accessible from the BOS:
    - Accessed sensors (inputs).
    - Used actuators (outputs).
    - Associated equipment devices/construction elements.
  - o Relevant information:
    - Name of the component and ID in the BOS; it will be associated an RFID tag ID with it in the MPTs.
    - Type of the component and association with a given infrastructure (e.g. electric/water/senor network, etc.).
    - Component location, i.e. where it is placed in a given schematic of e.g. electric/water network, construction diagram, etc.

---

<sup>94</sup> In principle, it was intended to use both active and passive RFID tags ([www.rfidinfotek.com](http://www.rfidinfotek.com)). Then it would be necessary to carry out performance testing and make some adjustments. Due to a problem in the delivery of the passive tags, as of May 2010, it was decided to deploy only **active** RFID tags (small size) in the Mock-up. Currently, it is not feasible to achieve both active and passive reading on the same physical device, so I3CON partners limited to only one technology until a suitable multi-tag reader is available. There was some delay in the development of the BMS in I3CON WP6, so Intracom, Lonix and Thales had to develop their services separately: although most functions can be accessed from the BOS and WSN directly, the localisation/positioning and RFID identification functions are not linked to the BOS.

<sup>95</sup> Terminal adaptation features are limited due to delays with availability of LON/VTT web services that required ICOM to develop autonomous solutions. Adaptation is limited to supporting any Mobile 5/6 device (screen resolution, orientation), available physical interfaces by offering multiple control options. The solution is made to operate independently from connection to BACS/BMS, where in the loss of connectivity the mobile device will continue operation using offline pre-cached data.

- Physical construction diagrams of the Mock-up and the schematics of the infrastructures deployed (drawings<sup>96</sup>).
- **Use of the Mobile Browser** – a PDA-based application for accessing Building Management System from LON and TRT sensors, featuring:
  - o RFID localization and positioning (on the embedded map) system based on triangulation against either active or passive RFID tags.
  - o Active Wi-Fi RFID tags will be used operating in the 2.4GHz frequency band with similar operational range as Wi-Fi networks.
  - o Automated detection of RFID-tagged building equipment in the user vicinity for faster access to information about them (description, status, etc.).
  - o On-demand access to the Building Management System for static (LON server) and dynamic (VTT server) information – i.e. manual browsing.
  - o Multimodal interfaces employing Speech Recognition and Synthesis, automated context switching based on location and equipment status, terminal adaptation (MS Mobile 6 PDA only).
  - o Map (raster/CAD) support for self-orientation by marking own position and location of relevant equipment from the Building Management System.
- **Integration:**
  - o Confirmed with the WSN through direct link to TRT server<sup>97</sup>.
  - o Integration of the Rule Based Engine (RBE) and mobile applications with LON BOS and VTT BIM<sup>98</sup>.

### 3.6.2 RFID Tags deployment

- One or two on-metal long-range tags per room with few more medium-range ones (smaller in size) used both for aiding in positioning and equipment identification.
  - o This way requirements are still satisfied, although not for as low-cost as in the previous design (with passive RFID tags). Note that mobile passive RFID reader was not available for demo tags.
  - o The final location of tags will depend on the placement of the equipment controlled by the Mock-up BOS server. It is important to know the position of the different devices beforehand in order to better plan the tag deployment, minimise the number of tags per room and hence the deployment cost.
- **Active RFID tags:**
  - o The Wavetrend Small Asset Tag Activ™ TG801 [99] is specially designed for indoor asset tagging applications, such as for tracking and monitoring laptops, IT equipment and transport media.
    - Splash-proof, anti-tamper tags will immediately generate an alert if the tag is removed or becomes separated from the asset.
    - Active tags offer different user-configurable rates for its status transmission.

---

<sup>96</sup> Preferably maximum file size: 150 KB. Otherwise raster formats could be used, but the range of available features would inherently be low

<sup>97</sup> Data may be accessed through the VTT interface, but ICOM is inclined to keep the direct connectivity as a fail-safe option.

<sup>98</sup> Optionally, ICOM will (subject to a successful completion of link to LON services) provide access to BACS. There is no restriction on the type of data or time availability as ICOM tool performs direct call to web services from LON for data update so it is up to LON what info they will make available. This is now expected to be reinstated as core feature, unless problems with operation of LON/VTT interfaces arise (in that case, ICOM will resolve back to their autonomous fail-safe solution).

- o Operational range is around 10-15 meters to avoid overloading readers with irrelevant tag detection from neighbour rooms and to lower battery consumption. Having limited range, these tags are expected to function for around five years. Readers will be able to determine battery charge of the tags when read, so it is known in advance when the tag battery is close to depletion.
- o Installation depends on the type of application:
  - The standard method is by acrylic foam double-sided adhesive tape [100].
  - The tag is also available in a “wing-mount” version, offering two screw/rivet holes for fixing the tag to an asset.
  - Active tags are affixed onto selected equipment units and pre-defined places on the walls.

## 4 Construction: Components manufacturing & assembly and Systems installation

---

Previous chapters dealt with all the design issues of the Mock-up building that serves as I3CON demonstrator, detailing the components and systems deployed in the test-bed, and making reference to commercial brochures when additional data is needed. The installation of all the auxiliary systems conceived to measure the performance of the different developments proved to be extraordinarily complex, as a huge number of devices were necessary and all of them had to be fitted in a reduced space. For that reason, it was very important to bear in mind the full list of items to avoid clashes during the installation and a draft of the installation schedule so that different partners/subcontractors don't interfere in others' work.

This chapter teaches all the manufacturing and installations experiences and provide technical explanations for some design changes. Before constructing the Mock-up, it was necessary to detail as much as possible the Bill of Materials (BoM), the connections to be done for the monitoring and controlling issues, a schedule for the different tasks to be done, the location and the necessary services to be provided for the Mock-up working.

- **BoM:** a breakdown of all the products to be fitted in the Mock-up, including the item ID, manufacturer, product model and its characteristics, number of units, price, installation cost, and supplier information is compiled in a XLS file permanently updated by the factory staff and the design team, gathered in *Appendix IV*.
- **Wiring:** The Mock-up BOS handles numerous systems resulting in many signals (inputs and outputs), both digital and analog. Apart from the wireless sensors deployed by TRT, the rest of the equipment has to be wired to the LON modules. Metering devices, sensors deployed at different layers of the façade panels, indoor and outdoor sensors for measuring ambient and surface temperatures, water temperature and flow, presence, light, etc., as well as actuators for controlling the heat pump, water pumps, fan coil units, under-floor heating drives, water circuit valves, lamps, etc. have been wired according to the cabling document<sup>99</sup> (*Appendix V*).
- **Schedule** draft (detailed planning in a MPP file, *Appendix II*):
  - o Partners' components and systems specifications and detailed BoM: October 2009 – January 2010.
  - o Construction of structural components<sup>100</sup>: December 2009 – April 2010
  - o Components assembly and systems installation: January – August 2010
  - o Adjustments and tune-up: July – September 2010
- **Location** (*Drawing AR-01*):
  - o The Mock-up is situated in the yard of the SEIS' Factory: Finca Yema de Huevo, Las Cabezas de San Juan (Seville, Spain).
  - o Orientation: long sides of the module facing North (blind walls) and South (fenestrated walls).
- The following **services** needed to be provided:
  - o Water supply for domestic use and watering the plants.
  - o Electricity supply for the operation of electrical equipment.

---

<sup>99</sup> Drafted by [Sampsá Kosonen](#) (LON) and reviewed by Dragados' R&D team.

<sup>100</sup> The manufacturing times of this Mock-up building are not representative of SEIS' factory production rate: a typical prefabricated module takes usually 2 weeks to be completed, including all the services.



- o Electrical switchgear for the appropriate operation of electrical equipment, including relays, AC/DC converters, transformers, etc.
- o Broadband internet access for the remote monitoring and data collection.
- o Security and surveillance to check that all the systems are working properly (e.g. pumps are not working in vacuum, opening and closing windows and faucets, etc.).



*Fig. 4-1: Transport of the Mock-up to its final location [DRA-SEIS]*



*Fig. 4-2: Mock-up south elevation [DRA-SEIS]*



*Fig. 4-3: Mock-up north elevation [DRA-SEIS]*



## 4.1 Construction of the Mock-up structure

### 4.1.1 Floor slab + Metallic structure

- Conventional floor slabs for prefabricated SEIS' modules use between 1 and 1.5 m<sup>3</sup> of concrete.
  - o Typically, HA25 (2500 kg/m<sup>3</sup>).
  - o In case of using light concrete, the density is around 1400-1500 kg/m<sup>3</sup>.

Fig. 4-4 compares the conventional floor slab in SEIS' prefabricated 3D modules and the new solution conceived in I3CON, intended to prove the ease of integration of Uponor's under-floor radiant heating system.

Fig. 4-5 shows the main structure of the Mock-up: a concrete floor slab and metallic profiles configuring a torsion box. The diagonal studs are intended only for the transport of the module, and they are retrieved once it is assembled on its site.

Fig. 4-6 shows the mineral wool projected over the concrete slab. Over it, another layer of concrete is poured. Space is foreseen for the installation of Uponor's UFH Mini system.

One of the main reasons behind the application of this UFH Mini system is to gain headroom in the prefab modules, which dimensions are limited by transport. Therefore, it is very important that only 3 mm are poured over the UFH system. Moreover, if this layer is thinner, the system will have more thermal inertia and perform worse. For this reason, special care must be put when applying the self levelling mortar.

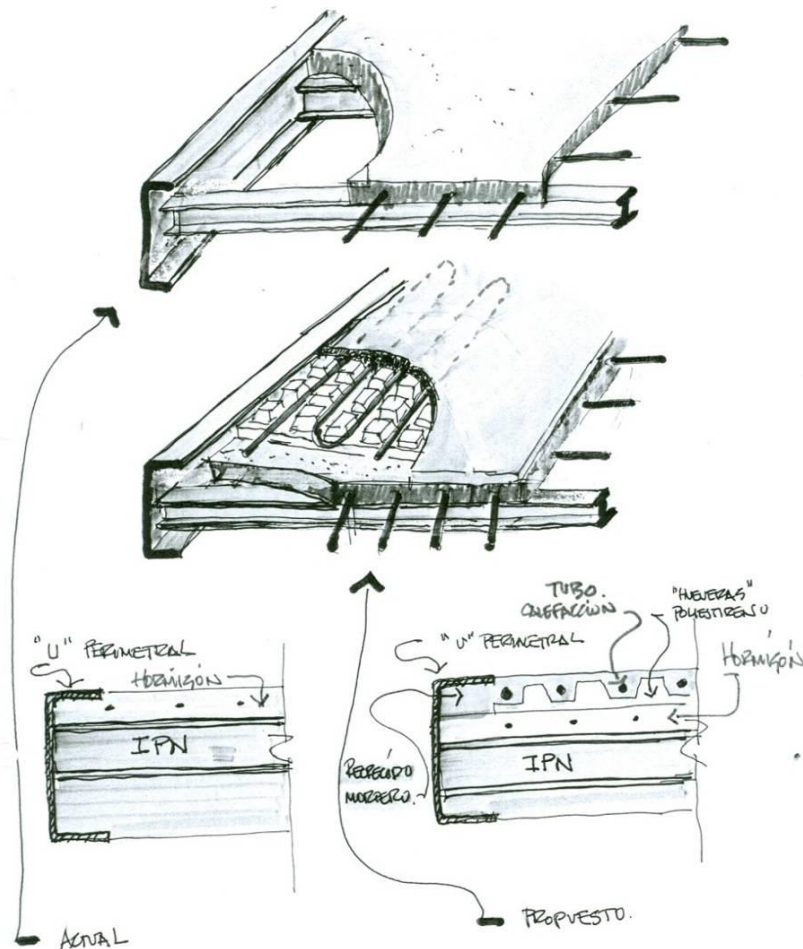

Fig. 4-4: Schematic of the integration of Uponor's underfloor heating system within the structural floor slab [DRA]



*Fig. 4-5: Mock-up metallic structure and concrete floor slab [DRA-SEIS]*



*Fig. 4-6: Details of the floor slab: mineral wool mortar and space for the installation of the UFH system [DRA-SEIS]*

#### 4.1.2 Roof deck

*Fig. 4-7* shows HVAC equipment such as the heat pump and the solar thermal collector. Their weight has to be borne by the roof system without damaging the underlying waterproofing membrane, so the paving consists of slabs of porous concrete over a base of XPS foam. The water deposit on the left hand side is intended for simulating the length of the pipes from the boiler to the use point in a detached house.

The east zone doesn't require a walkable roof system, so it only features a waterproofing membrane over a supplementary layer of puncture-resistant synthetic felt. The roof deck has been constructed with a slight step in order to evacuate the rain water (*Fig. 4-8*).



*Fig. 4-7: HVAC equipment on the roof [DRA-SEIS]*



*Fig. 4-8: Waterproofing membrane on the roof deck [DRA-SEIS]*

## 4.2 Façade panels

Most of the Mock-up façade panels are made of GRC (Glass-fibre Reinforced Concrete). Next epigraphs describe the constituent materials, the manufacturing and curing processes and give instructions for handling and storage. Later, the learning of the manufacture of the different façade panels of the Mock-up are gathered.

- **Constituent materials** of the GRC [101]:
  - o Alkali-resistant glass fibre EN 15422:2008 compliant.
  - o Cement.
  - o Fine aggregates, typically silica sands (max. size 1.2 mm; sand passing a 150 micron sieve shall be less than 10% of the total weight of sand).
  - o Water (clean and free from deleterious matter).
  - o Admixtures [102]:
    - Plasticizers and super-plasticizers<sup>101</sup>: decrease the yield point, increasing the fluidity.
    - Viscosity Modifying Admixtures (VMAs): increase the plastic viscosity without affecting the yield point, reducing the tendency to segregate and the friction during pumping and bleeding.
    - Note: the slump test mainly measure the yield point and the V-funnel test will measure the plastic viscosity, although this last is not part of any current recommended GRC testing programme yet.
    - Set retarders and accelerators (for hot and cold weather, respectively).
    - Water-repellent and anti-efflorescence chemicals.
  - o Aqueous thermoplastic polymer dispersions (acrylic based).
  - o Pigments, silica fume, meta-kaolin, fly ash, reinforcing fillers, etc.

*Table 4-1: Mix for spray grade18 [DRA-SEIS]*

Aggregate/Cement ratio	0.5 – 1.0
Water/Cement ratio	0.3 – 0.375
Glass-fibre content (% by weight of total mix)	4.0 – 5.5
Polymer solids contents (% by weight of cement)	4 – 7

- **Manufacturing** is done by the **direct spray method**<sup>102</sup>. Steps:
  - o Specialist carpenters make/configure a wooden mould, keeping in mind all the cast-in features of the façade panel, and a deshuttering coating/release wax is applied over it.
  - o Dry ingredients are batched by weight before the cementitious slurry is prepared in a high shear mixer (the consistency of the mix is tested by measuring the slump).
  - o Sometimes, an initial layer (facing coat) is sprayed without fibre but containing decorative sands or aggregates and often pigments. This coat may be allowed to stiffen but the first GRC layer must be applied before initial set takes place.
  - o Spraying is done with specialist equipment that allows the simultaneous deposition of known quantities of cementitious slurry and glass fibre which is chopped from roving<sup>103</sup>.

<sup>101</sup> Plasticizers are based on lignosulfonate, and super-plasticizers on sulfonated melamine, naphthalene formaldehyde and polycarboxylate ether.

<sup>102</sup> Further research is suggested in the field of self-compacting premixed GRC.

<sup>103</sup> To ensure that the specified percentages of glass fibre and cementitious slurry are delivered, the spray gun is calibrated using, respectively, the bag test and the bucket test. When the equipment gives continuous readings of glass and slurry output these tests are unnecessary.

- o The sprayed GRC layers (3–4 mm) are compacted by a hand roller before spraying the next layer<sup>104</sup>, until completion of the component, which is finished with a trowel.
- **Curing:**
  - o Once the initial set has taken place, the mould is covered with a polyethylene film.
  - o Moist curing (for non-polymer grades): ideally, at controlled temperature and humidity (20 °C, 95% RH) and during 7 days, in order to achieve the expected physical properties and avoid excessive shrinkage.
  - o Filled moulds are stored at temperatures between 5°C and 40°C on a level surface and supported in such a manner that they will not bow or twist, and are not moved until demoulding.
  - o The GRC component is demoulded once it has gained sufficient strength to be removed from the mould and transported without being over-stressed.
- GRC components must be stored, handled and transported in such a way that:
  - o No part of the component is overstressed.
  - o Bowing or twisting is not induced in the component.
  - o No damage is caused to any part of the component, particularly edges and corners.
  - o No permanent staining or discoloration is caused either by the storage conditions or the stacking/protection material.
  - o For large components, special sockets and loops are embedded in the component in order to demould it with a lifting frame. Idem for its loading, transporting, unloading and handling.

#### 4.2.1 GRC Stud-frame panels with embedded glass blocks (P-01 & P-11)

While the usage of glass blocks is an increasing trend, they are brittle and cannot tolerate sudden changes in temperature without cracking if their expansion is too high. The reason behind the manufacturing of P-01 and P-11 with such features was precisely to check how well the glass blocks would endure the thermal expansions and contractions of the supporting GRC shell. In addition, the GRC shrinks as a consequence of the curing process, which takes up to one month.

After the summer (temperatures in Seville reached up to 45 °C), some cracks appeared as a consequence of the tensile stresses, indeed. As for the Mock-up façade panels, the aesthetic effect of the cracks is imperceptible so far but, for future panels, some expansion joints must be foreseen if a great number of glass blocks are intended to be embedded.

#### 4.2.2 Pyramidal GRC shells + PCM Plasterboards + ECGU (P-02 & P-10)

- **GRC Shell:**
  - o The production of GRC shells with special shapes, double curvature, etc. is an increasing trend. Façade panels P-02 and P-10 (featuring pyramidal shapes) have been manufactured with the same process than flat panels, with the only singularity of special moulds shown on *Fig. 4-9*.
  - o These GRC shells are getting dirty faster than planned, so it seems that they will need to get painted. This doesn't affect the thermal performance, but is an argument for the Sandwich Framex concept, which allows renovating the external cladding more easily.

---

<sup>104</sup> After the final layer has been sprayed, the thickness of the GRC is checked using a depth gauge and compared to the design thickness, since no part of the component should be below this thickness. Over-thickness is to be expected at corners or areas with a deep profile, as long as the component does not exceed the maximum design weight. At flat areas, 4 mm is the maximum over-thickness permitted.





*Fig. 4-9: Special moulds for conforming pyramidal shapes on panel P-10 [DRA-SEIS]*

- **Plasterboard sheeting:**
  - o The commercial PCM-enhanced gypsum board detailed in § 2.2.3 is a discontinued product, but some samples were supplied on behalf of Dragados' collaboration with Knauf and NTUA<sup>105</sup>.
  - o Their installation is the same as for conventional drywalls, and their performance will be assessed according to the measurements plan (§ 5.3).
- **Electro-chromic glazing:** see § 4.5.

#### 4.2.3 Sandwich Framex with PCM Boxes (P-03 & P-09)

Commercial PV panels and wooden laminates for special finishing have been incorporated to the external cladding of P-03 and P-09, but the main innovation of this panels lies within the Sandwich Framex core in the form of PCM packages (*Fig. 4-10*), working together with EPS insulation to improve the envelope thermal performance (*Fig. 4-11*).



*Fig. 4-10: PCM boxes and installation within the core of the sandwich panel by specialized factory staff, over the innermost GRC skin [DRA-SEIS]*

<sup>105</sup> Prof. Hans-Ulrich Hummel (Knauf) and Prof. Maria Founti (National Technical University of Athens).

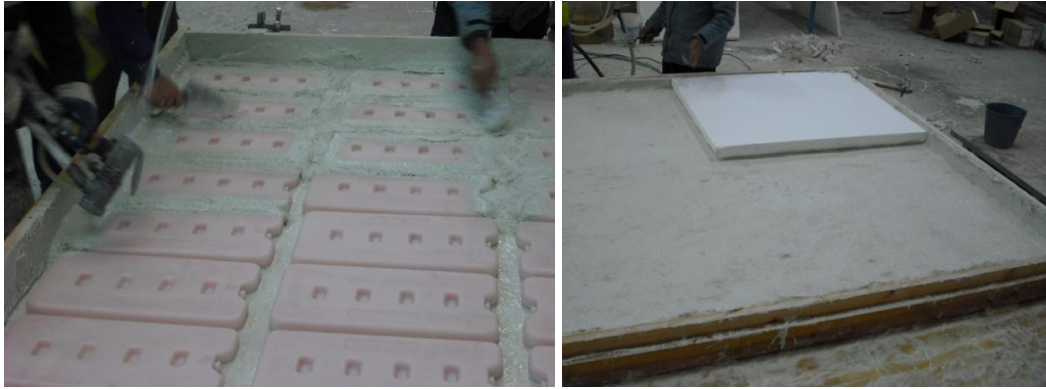

Fig. 4-11: After the PCM boxes have been placed, GRC ribs are projected to stiffen the panel; over them, EPS foam is laid to provide thermal insulation [DRA-SEIS]

- The thermal performance will be assessed after the measurements outlined in § 5.3 & 5.4 have been carried out (see also § 6.2.1). In the meanwhile, some issues have already been tested, e.g. manufacturing data for comparison with another prefab GRC sandwiches of similar size but without PCM boxes:
  - o Weight: the incorporation of the PCMs means a significant weight increase. The panels weigh between 1000 and 1300 kg (depending on the presence of openings).
  - o Curing time: approximately the same.
  - o Innermost surface: this side was over the mould whilst manufacturing, so the finishing is very smooth and doesn't need any additional painting/sheeting. There was a concern about if the presence of the PCM boxes behind the innermost GRC shell would result in stains, but such faults had not appeared after 6 months.
- A commercial PV panel has been incorporated to the façade panel P-03. Since it is not to be connected (the intention is not to take advantage of the yielded electricity, but to prove the amenability of the Sandwich Framex typology for supporting PV panels), it won't be necessary to refrigerate the back side of the PV panel, although it would be easy because the assembly is a ventilated façade. The only purpose of the cladding elements shown on Fig. 4-12 is decorative.



Fig. 4-12: Left, schematic of the wooden laminates and the PV cells lay-out to be supported by the façade panel secondary structure (the metallic profiles of the Framex); Right, once installed over façade panel P-03 [DRA-SEIS]



#### 4.2.4 Sandwich Framex with vegetated panels (P-04 & P-08); Watering system

- **Plants evolution:**
  - o During the winter, the plants were grown in a greenhouse. At the end of the spring the vegetated panels were shipped from Pozuelo de Alarcón (Madrid) to Las Cabezas de San Juan (Seville), approx. 600 Km, by truck.
  - o Before being definitively installed on their respective façade panels, plants were kept for some weeks at SEIS' factory warehouse to get them used to the climate (*Fig. 4-13*).
  - o Vegetated cells were put on place over the Sandwich Framex supporting profiles at the beginning of the summer, during which their endurance was tested.
  - o After two months, the plants on the upper row of the south façade dried up. This was due both to the high temperatures reached during Summer 2010 in Seville and the problems with the automated watering, but is also indicative of the non-suitability of some species and the adequacy of other ones. The maintenance of the vegetated panels (i.e. the watering system) is detailed in § 4.2.4.1.



*Fig. 4-13: Plants horizontally stocked for their better growing and align in front of façade P-08 prior to their installation [DRA-SEIS]*

- **Supporting structure and lay-out:**
  - o The metallic external frame (the “framex”) consists of four vertical profiles (DxW = 70x40 mm)<sup>106</sup>. The layout of the profiles is done according to the dimensions of the GRC shell (W = 2160 mm), the vegetated cells once they are wrapped in the felt (W = 536 mm), the necessary tolerances for assembly and adjustment (20 mm), and the position of windows. In principle, profiles can be separated between 450 and 600 mm (*Fig. 4-14*). Ideally the profiles at the extremes shouldn't be visible from the outside (*Fig. 4-16*). The assembly of the vegetated cells is done starting with the central units of each façade, being the other ones fitted around it bearing in mind the total dimensions and the allowable tolerances.
  - o The angled cleats shown on *Fig. 4-15* not only bear the load of the vegetated cells, but also give support to the drip irrigation system that is concealed behind them (enough space must be foreseen for the 16 mm pipes, see § 4.2.4.1). Therefore, the final shape of this angle is an “L” with four passing-through bolts (only two for those on the laterals), holding this way the cells both over and under it. These bolts are easily threaded in and out, so the assembly/disassembly of the vegetated panels is easily done in the direction perpendicular to the façade. To ensure this, even when one cell is filled with more substrate than others and fit too tight, the cleats have a vertical tolerance of 20 mm.

<sup>106</sup> For panels P-03 & P-09 they are 40x40 mm; both profiles are considered, depending on the loads imposed.

- o The load is calculated assuming grown plants and humid substrate ( $50 \text{ Kg/m}^2$ ), so each vegetated cell weights approximately 12.5 Kg. Supporting angles with thickness  $t = 1.5 \text{ mm}$  should be enough, but they were produced with  $t = 2-3 \text{ mm}$  to be sure that they will not bend<sup>107</sup>. It is important that the cleats are wide enough (e.g. 75 mm for the central pieces, 50 mm for the lateral ones) in order to accommodate the accumulative errors during the assembly of the cells throughout the façade width. Those tolerances are also intended to maintain the same dimensions of the vegetated cells as much as possible to take advantage of modularity and industrialization (although they can be tailored, e.g. around openings to cover the whole façade, so we are talking about mass customization –see Fig. 4-17). The length of the cleats (longest branch of the “L”) is 100 mm.



Fig. 4-14: Left, schematic of the vegetated cells lay-out and the Framex; Right, P-08 before completion: the underlying metallic profiles can be seen behind the green panels [DRA-SEIS]



Fig. 4-15: Supporting angles and installation over P-04 Framex [DRA-SEIS]

<sup>107</sup> After some weeks of watering, the supporting angles may start to corrode. Structurally, the supports are over-dimensioned with  $t = 3 \text{ mm}$ . This way, the corrosion remains as an aesthetic issue (in fact, the rusting colour matches better the green modules). The solution is a compromise between weights, supporting capacity and price (more material/galvanizing).



Fig. 4-16: Vegetated panels after installation onto Framex façade [DRA-SEIS]



Fig. 4-17: Details of the vegetated panels around the window opening [DRA-SEIS]

#### 4.2.4.1 Maintenance of the vegetated panels (Watering system)

- Due to the vertical positioning of the plants and the annual rainfall in Seville, it is not possible to take advantage of rainwater, so **external water supply** is necessary not only in summer but during the whole year.
  - o The state of the vegetation is being checked every week by the factory staff.
  - o Maintenance operations (i.e. fertilisation) can be implemented in the watering system.
  - o Note: This installation requires **electricity supply**.
- The watering is done by means of **drip irrigation** (Fig. 4-18 and Fig. 4-19).
  - o Water is delivered through polyethylene (PE) pipes ( $D_{ext}=16.1$  mm,  $D_{int}=13.7$  mm) [104] and arrow drippers [105] driven into the vegetated cells:
    - North façade: 22 drippers, 8.5 l/h each = 187 l/h in total, i.e. water flow = 3.11 l/min.
    - South façade: same data.
    - Small gutters are fitted both at the bottom of the panel and at window lintel in order to collect the leaking water.
  - o Water supply and leaking water is collected in a small chest located under the façade panel and re-circulated by means of water pumps 3CP80E [106].
  - o In order to ensure that the water tank is neither empty nor overflowing, there is a level switch [107] that operates in the filling mode:
    - When the level is in the lowest position, an electrovalve [108] opens the water mains supply, and it stops when the set level is reached.



- Wiring connections are shown on *Fig. 4-20*; only the blue and black cables have to be connected (brown cable is for the draining mode).
  - o Watering is done 3-5 times per day, during 30-60 minutes each time; the task is automated with a programmer SL 1600 modular [109]:
    - The programmer tells when the pump has to operate, but it doesn't have power enough for triggering the pump, so an intermediate relay is needed.
    - A water meter is fitted at each vegetated panel in order to measure the water consumption.
    - **Note:** this controller is not integrated in the BOS.
  - o It is advisable to create a bypass that allows the watering directly from the mains supply, in case the pump breaks down.
    - For this, it is necessary to fit a valve for bringing the water pressure down to 4 bar (note that the mains pressure is higher).
    - Manual valves are fitted so that maintenance operators can choose between watering from the tank or from the mains.
- **Note:** Total Dynamic Head (TDH) is the total equivalent height that a fluid is to be pumped, taking into account friction losses in the pipe. It is calculated through the following formula:

$$TDH = Suction\ Head + Discharge\ Head + Head\ Loss.$$

- o Suction Head (a.k.a. Static Lift) is the height the water will raise before arriving at the pump. In this case it is negligible.
- o Discharge Head (a.k.a. Static Height) is the maximum height reached by the pipe after the pump. In this case it is **3.5 m**.
- o Head Loss: In any real moving fluid, energy is dissipated due to friction, as well as turbulence, unless the flow is laminar. Head loss is divided into two main categories:
  - Major losses associated with energy loss per length of pipe
  - Minor losses associated with bends, fittings, valves, etc.
- **Water pump selection:**
  - o For relatively short pipe systems, with a relatively large number of bends and fittings, minor losses can easily exceed major losses. Minor losses are usually estimated from tables using coefficients. Most water pump manufacturers provide applications for calculating the duty point as a function of the total flow and total head.
  - o Whilst selecting the pump, it must be considered the type of fluid (in this case, clean water) and the application limits. For example, when considering a submersible water pump, the maximum diameter is limited by the water tank dimensions (this led to discard submersible models).

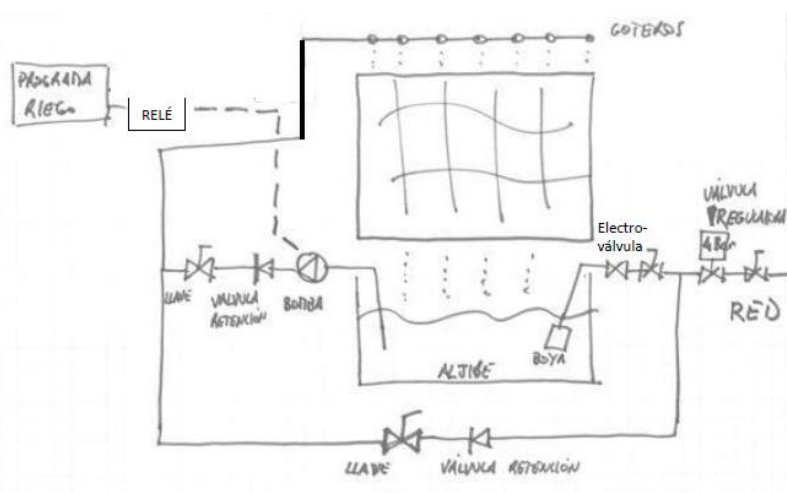

Fig. 4-18: Schematic of the watering system [DRA]

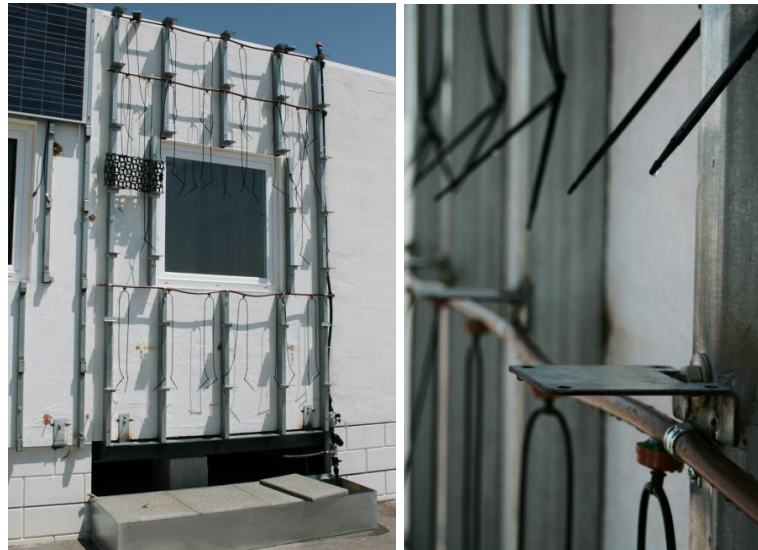

Fig. 4-19: Left, irrigation system deployed on façade P-04; Right, drippers and water pipes, supported by the angled cleats that also bear the weight of the vegetated cells [DRA-SEIS]

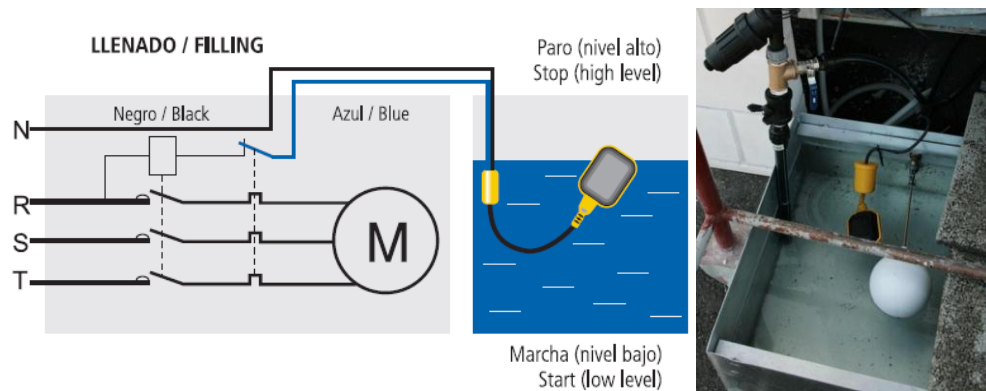

Fig. 4-20: Automation of the water tank filling by means of a level switch fitted inside the water tank beneath the vegetated façade panels [AKO / DRA-SEIS]

#### 4.2.5 Façade panels with improved acoustical features (P-05 & P-07)

The Mock-up bathroom is enclosed with GRC sandwich panels that incorporate soundproofing material in the core and is finished with a special built-in pattern (40 x 40 mm) in order to diminish the reverberation time. Again, these panels are manufactured with slight changes in the conventional process (Fig. 4-21).



*Fig. 4-21: Left, manufacturing process of the GRC sandwich panel with mineral wool filling; Right, special indoor finishing pattern for improving acoustical performance [DRA-SEIS]*

#### 4.2.6 Eastern and Western Fronts (P-06 & P-12)

- In principle, the sheet-metal panel was covered by metallic composite strips screwed over thin profiles at the top and bottom of the underlying panel. Those profiles proved to be insufficient (if someone leant on the wall, it would bend inwards), so intermediate profiles should have been necessary. Finally, it was decided to install rear-ventilated fibre-cement panels, as a way for the renovation of prefabricated modules with sheet-metal enclosures.
- The manufacturing of the façade panels P-12 didn't bear any kind of innovation, apart from the application of new finishing that are glued to the GRC shell.



*Fig. 4-22: Left, façade P-06 featuring the sheet-metal panel before being clad with composite panels; Right, P-12 featuring different finishing sideboards [DRA-SEIS]*

## 4.3 Piping system

### 4.3.1 Tee system Vs Manifold system

Traditionally, the pipes used for tap water system were rigid, so the most common way to change direction was with fittings called elbows. Bending technique wasn't suitable for most of materials or wall thickness. With such rigid materials, the traditional system to install the pipes was the Tee System. The above situation changed with the use of flexible pipes, like PEX-A, which can be bent when a change of direction is needed, allowing the Manifold System.

Since there is no boiler in the Mock-up (DHW comes from the water tank at 55 °C) all the water conduits can be of PEX. Nevertheless, according to the CTE, those coming from the boiler/heater (primary circuit) must be of copper.

#### 4.3.1.1 Tee System

Traditional installation system (*Fig. 4-23*) used rigid pipes, although it can be used also with flexible pipes.

- Advantages:
  - o It uses less meters of pipe than the manifold system.
- Disadvantages:
  - o There are more joints than with the manifold system.
  - o The joints are often inaccessible within the floors or walls.
  - o There are temperature and pressure variations due to the fact that one pipe has more than one draw-off point.
  - o The design work is more complicated, as most engineers wish to reduce the pipe diameter, from the beginning of the system to the end, which is why more careful calculations are needed to determine the various pipe sizes.

#### 4.3.1.2 Manifold System

The basic principle of the manifold system (*Fig. 4-24*) is to provide joint free pipe runs from a centrally positioned manifold to each water end point. This system takes advantage of the flexibility of plastic pipes to make changes of direction.

- Advantages:
  - o The system can be designed with one single pipe dimension from the manifold to the draw-off point, which simplifies design and installation work.
  - o With joints only at the manifold and the end point, the risk of leakage from joints is considerably reduced and there are no connections within the walls.
  - o Since there are no other draw-off points on the same pipe, pressure and temperature variations are minimal when taps are turned on and off.
  - o Small pipe diameters and fewer fittings save on installation time and labour costs.
- Disadvantages:
  - o It uses more pipes than Tee system.



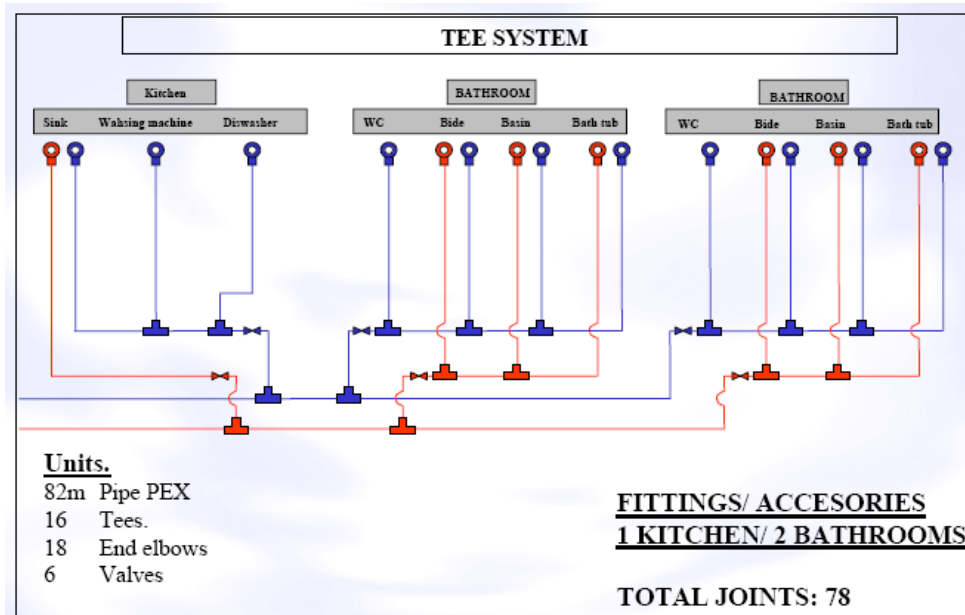

Fig. 4-23: Tee system [UPO]

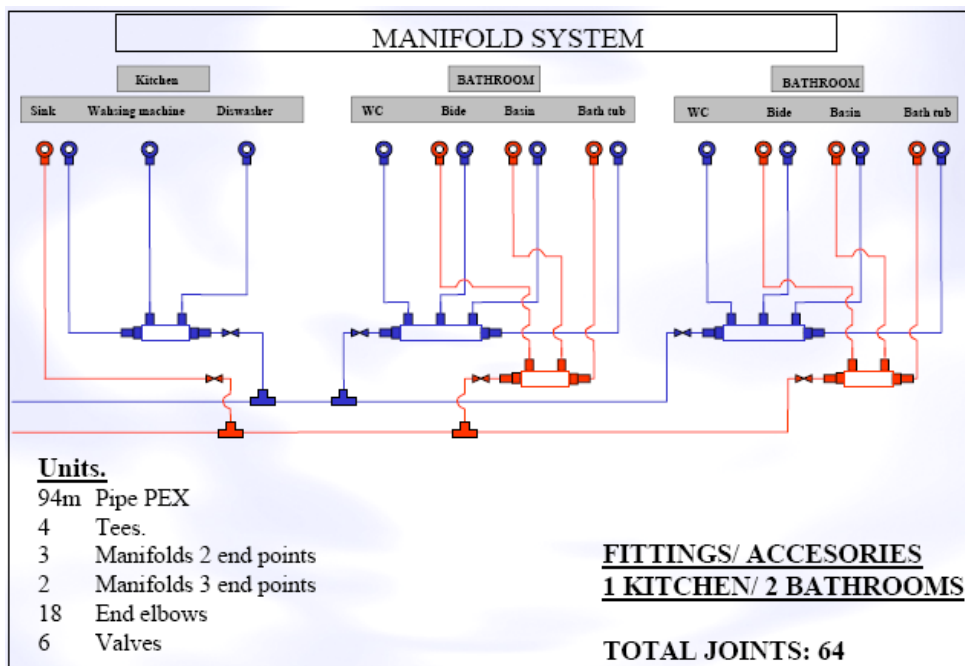

Fig. 4-24: Manifold system [UPO]

### 4.3.2 Installation of the recirculation and fire extinguishing systems

- Installation: certified subcontractor under Uponor's surveillance.
- Metering devices and recirculation pump: to be integrated within the BOS.
- Fire extinguishing system: it was proposed to use the sink in the kitchen (where the sprinkler is located) to discharge the water running through the fire extinguishing circuit, thus saving the return pipe to the WC (located at the bathroom at the other side). Nevertheless, for the auto-checking of the fire extinguishing system being effective (in the sense of preventing dirt getting embedded in the pipes), it is necessary a diameter of 25 mm (flushing the toilet requires quite a water flow), while kitchen sink pipes are usually only 16 mm in diameter.

## 4.4 Installation of the Under Floor Heating system

- **Mini UFH installation:**
  - o First, the cast concrete floor slab (that must be clean and absorbent) is coated with a synthetic-resin-based water dispersion primer [110]. Then plastic mini chambers (thickness 12 mm) are laid in order to guide the water pipes for the UFH system (Fig. 4-25).
  - o The water pipes, following the design detailed in previous § 2.4, are collected in the central manifold where the thermal drives control how much water goes into each circuit, and at what temperature, according to the instructions of the BOS (Fig. 4-26).
  - o Over the plate, 3-5 mm of ultra-fast drying, self-levelling, cement-based compound [111] is poured for levelling the surfaces. Finally, the stoneware flooring is received with fast-setting cementitious adhesive [112], applying anti-efflorescence water-repellent grout [113] in the joints.
  - o Commissioning:
    - The installation was done by a certified local installer under Uponor's surveillance.
    - Times: 1 day + 1 day during which nobody can walk on it.



Fig. 4-25: Primer coating (left) and plastic chambers (centre) laid onto the Mock-up floor for the Mini UFH system water pipes, installed by specialist staff (right) [DRA-SEIS]



Fig. 4-26: UFH installation (left); all the circuits are collected in a manifold case (centre); water temperature and flow are controlled by the thermal drives (right) [DRA-SEIS]

## 4.5 Assembly of the ECGU, and lighting strategies

- **Illuminance levels:**
  - o Unit: lux (lumen/m<sup>2</sup>).
  - o The outdoor light level is approximately 10,000 lux on a clear day.
  - o Wired indoor light sensors deployed in the Mock-up measure between 0 and 2,000 lux.
  - o When the ECGU is off, the indoor lux level depends, obviously, on the outdoor light level. There is no difference regarding a conventional window.
  - o When the ECGU is on, the lux level measured with the different glazing states are:
    - Clear state: 750 lux.
    - Intermediate state: 240 lux.
    - Dark state: 140 lux.
  - o The optimum lux levels for indoor activities can be found on *Table 4-2*.
  - o Control logic:
    - Threshold for the BOS activating the artificial lighting: 500 lux<sup>108</sup>.
    - Above 1,000 lux, the ECGU should change to a darker state to abate glare.

*Table 4-2: Recommended light levels [Adapted from EN 12464-1:2002]*

Activity / Work space	Lux
Working areas where visual tasks are only occasionally performed	100 - 150
Warehouses, Homes, Theatres, Archives	150
Easy Office Work, Classes	250
Normal Office Work, PC Work, Study Library, Show Rooms, Laboratories	500
Supermarkets, Mechanical Workshops, Office Landscapes	750
Normal Drawing Work, Detailed Mechanical Workshops, Operation Theatres	1,000

- **Control logic** for the combination of HVAC, ECGU and artificial lighting depending on presence and temperature:
  - o If there is nobody in the room, the window regulates itself in order to be always at the set temperature value (e.g., 24 °C). Lights are OFF.
  - o Whenever the occupancy sensor detects human presence, the ECGU regulates itself in order to reach the set lux level (up to users' will depending on the activity to be carried out in that room, *see Table 4-2*). Note that this level will be usually below 750 lux, so the ECGU performs well in its clear state. If the outdoor daylight is not enough, then the artificial lighting is switched on, with the intensity growing gradually until the desired light level is reached.
  - o If the ECGU was decided to be tested in other locations different from Local-1 (e.g., in the southern windows of rooms Local-2 and Local-3), the window sashes could be interchanged in together with the cabling coming out from the window pane and the control unit. The sandwiches of the façade panels P-03 and P-04 have embedded conduits to allow the cabling which runs through the technical ceiling and comes down to the bottom-right (looking from the inside) corner of the window.
- **Installation:**
  - o The glazing is fixed to the window sash by means of standard sealing material. The window fitting is the same than for a conventional window pane.
  - o The material was ordered on November 2009 and was shipped to the SEIS' factory by truck on December 2009. Following, a list of the material that was delivered:

<sup>108</sup> The control logic of the ECGU should be reviewed because, presently, when the ECGU is in the minimum glazing state, the lights are switched on by the BOS (this is not very environmental friendly). A good thing about the BOS is that set values can be easily changed for tuning up and adjustment.

- EC glazing (1 unit) with its corresponding control box.
  - Power supply: SGR sent to LON a description of the power supply to be used, and LON provided the material to integrate this power supply in their BOS.
  - Cable from EC glazing to power supply (with its connectors).
  - Cable from power supply to technical ceiling.
  - Connector 5 pins.
- o Eventualities:
- Handling: the ECGU is extremely delicate. During the transport, the conventional glass pane was damaged and needed to be repaired. After being fixed, a special purpose room was arranged for its storage until its installation.
  - The control unit broke down, allegedly for being supplied with 24 V instead of 12 V. A new control unit was delivered by SGR.
  - SGR did not visit SEIS' factory to assist staff during the installation of the glazing, but they provided the following tables and figures in order to make it easy to install for the subcontracted electrician.
- o Explanation of *Table 4-3 and Table 4-4*:
- Pins 1 and 2 need 12 Vdc. This voltage does not need to be very well stabilized, so it can be between 10 V and 14 V.
  - Pins 3, 4 and 5 do not need voltage.
  - When a bit value is set to "1", it means that the pin is connected to the ground; a bit set to "0" means that the pin is floated.

*Table 4-3: ECGU connection pins. Reference of the 5 pins connector: M12 Connector Binder 713 09-0433-387-05 [SGR]*

<b>M12 Connector Binder 713 09-0433-387-05</b>	<b>Function</b>	<b>Switch (v. g. Lorlin BCK 1002)</b>	<b>12 V Power</b>
Pin 1	GND	E	(-)
Pin 2	V+ (10 to 14V DC)	n.c.	(+)
Pin 3	Switch Bit 0	A	n.c.
Pin 4	Switch Bit 1	B	n.c.
Pin 5	Switch Bit 2	C	n.c.

*Table 4-4: ECGU positions. Bit "1" means connected to ground, and bit "0" floated [SGR]*

<b>Position 1</b>	100	-1.2V
<b>Position 2</b>	010	0.7 V
<b>Position 3</b>	110	1.4 V



*Fig. 4-27: Left, detail of the ECGU spacer; Right, the connectors for power supply [SGR]*



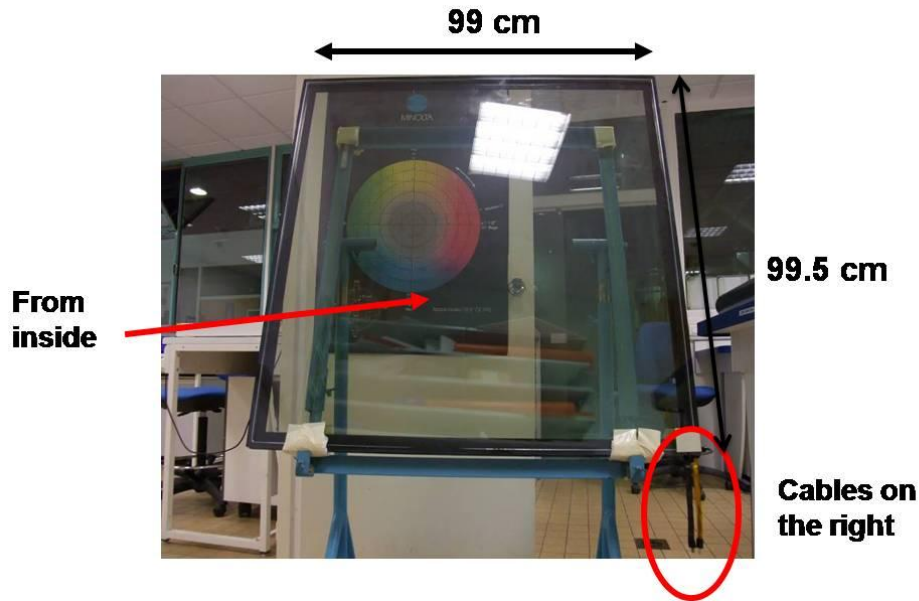

Fig. 4-28: Electro-chromic glazing unit. Dimensions and position of the power and control cables looking from the inside [SGR]

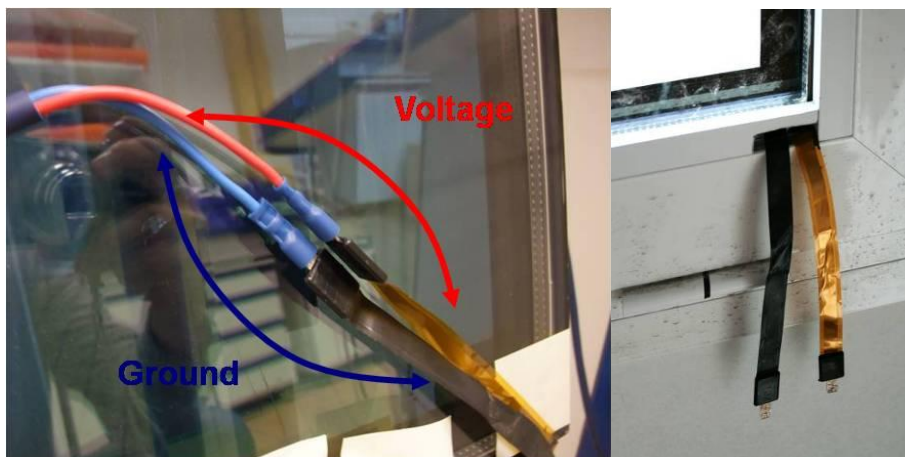

Fig. 4-29: Left, ECGU voltage (red) and ground (blue) connections; Right, cables hanging from the window sash, previously milled for that purpose [SGR]

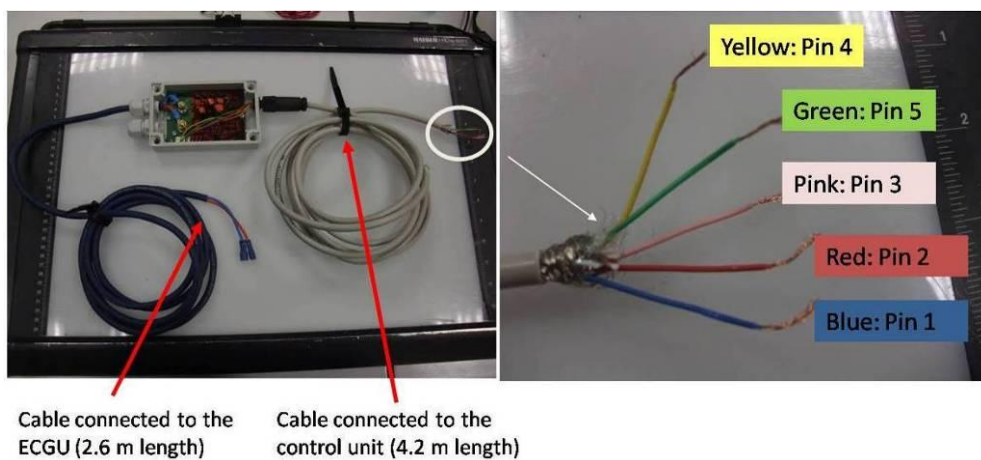

Fig. 4-30: Left, ECGU power and control cables; Right, details of the cables to be connected to the pin connector of the control box [SGR]



*Fig. 4-31: ECGU Control box with the pin connector (left side) and the voltage (red) and ground (blue) cables [SGR]*



## 4.6 Installation of the auxiliary HVAC Systems

- All the equipment was installed according to manufacturers' installation manuals. Following, some comments from the MEP engineers:
  - 3-way valves: it is difficult to tell when they are totally open/closed because the thread doesn't seem to block at any point if they are not properly fitted (special care must be taken by the installer).
  - Water temperature inside the pipes is measured after the collectors instead of at the faucets (this doesn't affect the measurements).
  - Each room can be monitored and controlled independently by means of the calorie meters and the electro-valves. The calorie meters read impulsion and return temperatures accordingly, but energy consumptions are measured either in KWh or in MWh; this range of magnitude is not suitable for the Mock-up, but for big installations such as multi-housing buildings, so the readings are rougher than intended.
  - The supporting auxiliary structure of the thermal collectors is delivered by the manufacturer/distributor of the solar system. It is necessary to foresee space for the accumulation tank, which must be located at a lower height than the thermal collectors. Therefore, it is placed in the kitchen.
  - DHW has to leave the water tank at 55 °C (set-up temperature).



*Fig. 4-32: Fan-coil units (left), pipes and controlling valves (centre) and water tank for DHW (right) [DRA-SEIS]*

## 4.7 Multi-Services Trunking System

- **Installation (Fig. 4-33):**
  - o The MSTS will be attached vertically to the wall of the cabinet using two holders (210 mm diameter will fit the outside diameter of the run at these heights) to be fixed to the wall (at 700 mm and 1400mm above the floor).
  - o Operational sink (*numbered 5 in Fig. 4-34*) is connected to a drain system and a water mixer tap to be fixed in position to the sink and ready to be connected to an inlet hot and cold water, which will be fed from the bottom of the MSTS (there is no reason for the sink being 1m from the axis of the MSTS, this dimension can be changed at fashion).
  - o Inlet air ventilation fan (*numbered 2 in Fig. 4-34*) should be installed in a conventional way and connected to mains electricity. Since this will be connected to the top of the MSTS, its output needs to be adapted for a 100 mm outer diameter air duct.
  - o New research being conducted by the University of Loughborough has shown that ventilation coming from floor may require less energy than coming from a wall or a ceiling, but in the Mock-up all the installation ducts run under the technical ceiling. Therefore, the ventilation circuit (*numbered 6 in Fig. 4-34*) will be installed under the ceiling in a conventional way and ready to be connected to the MSTS end.
  - o Light bulb (5 V) circuit with a switch to be installed above the sink and fed from the top of the MSTS. Besides safety reasons, the low voltages and currents are aimed to demonstrate a new way of providing lighting in buildings.
  - o The utilities needed to allow the testing of the MSTS consist of:
    - A source of 5 Vdc current (*numbered 1 in Fig. 4-34*) to be provided by a transformer and regulator that are fed from the 240 Vac.
    - Two incoming pipes (25mm outer diameter) providing hot and cold water (*numbered 4 in Fig. 4-34*) to be connected to the top of the MSTS.
    - An electric mains point (*numbered 3 in Fig. 4-34*) to provide 240 Vac at 13 A to the air extractor and the 5 Vdc box<sup>109</sup>.
  - o Dimensions for the position of the different components inside the portable cabinet are given in Fig. 4-35.
  - o The assembly of the MSTS required joining the two sections with silicon.



Fig. 4-33: MSTS fitted in the Mock-up kitchen: it can be seen the inlet and outlet runs, the water bypass and the operational sink [DRA]

<sup>109</sup> Dimensions of the transformer and electric mains boxes may vary as long as the output is enough to feed the air ventilation system and the other electrical components.

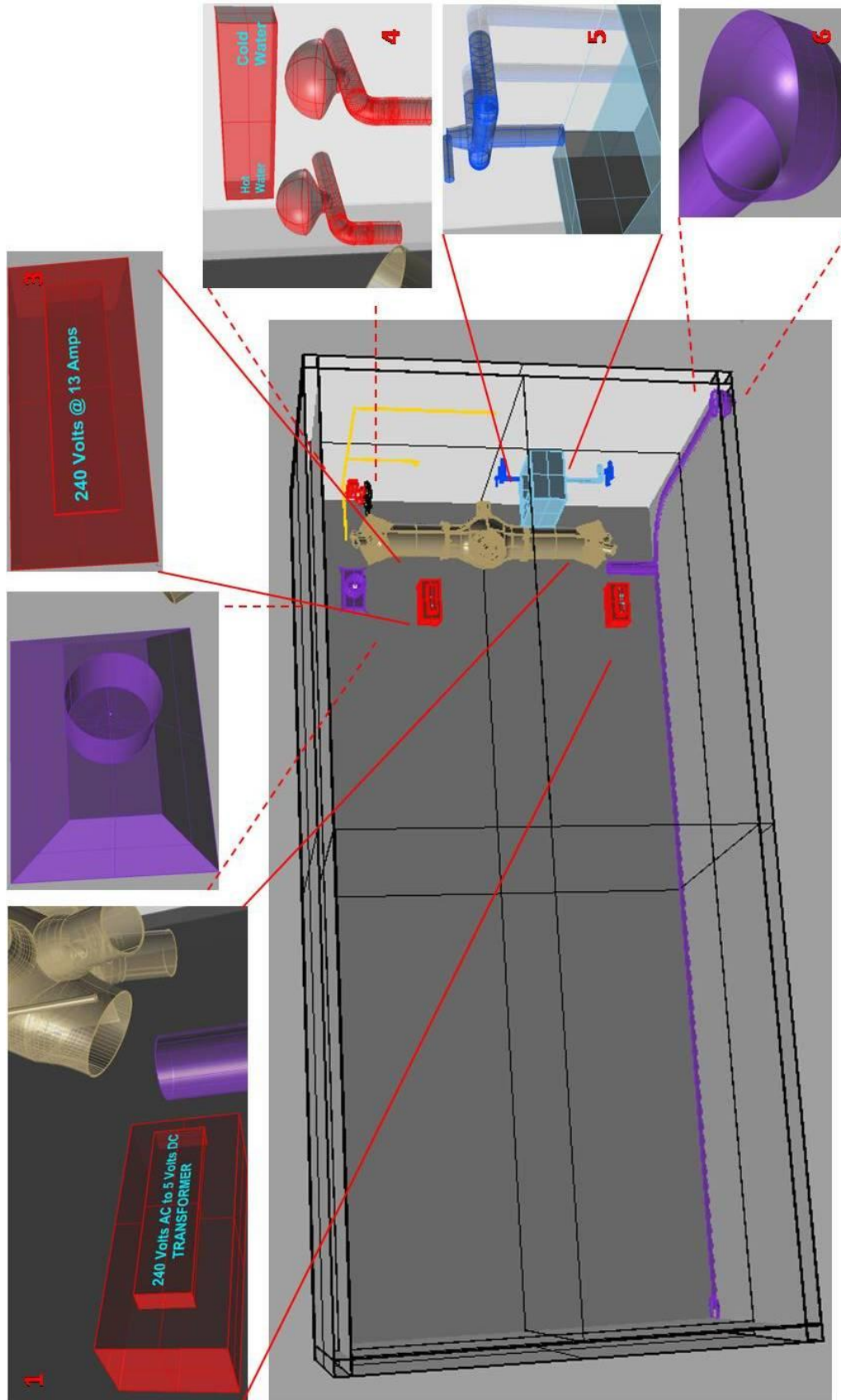

Fig. 4-34: Visual detailing of the requirements for the testing of the MSTs in the Mock-up [LOU]

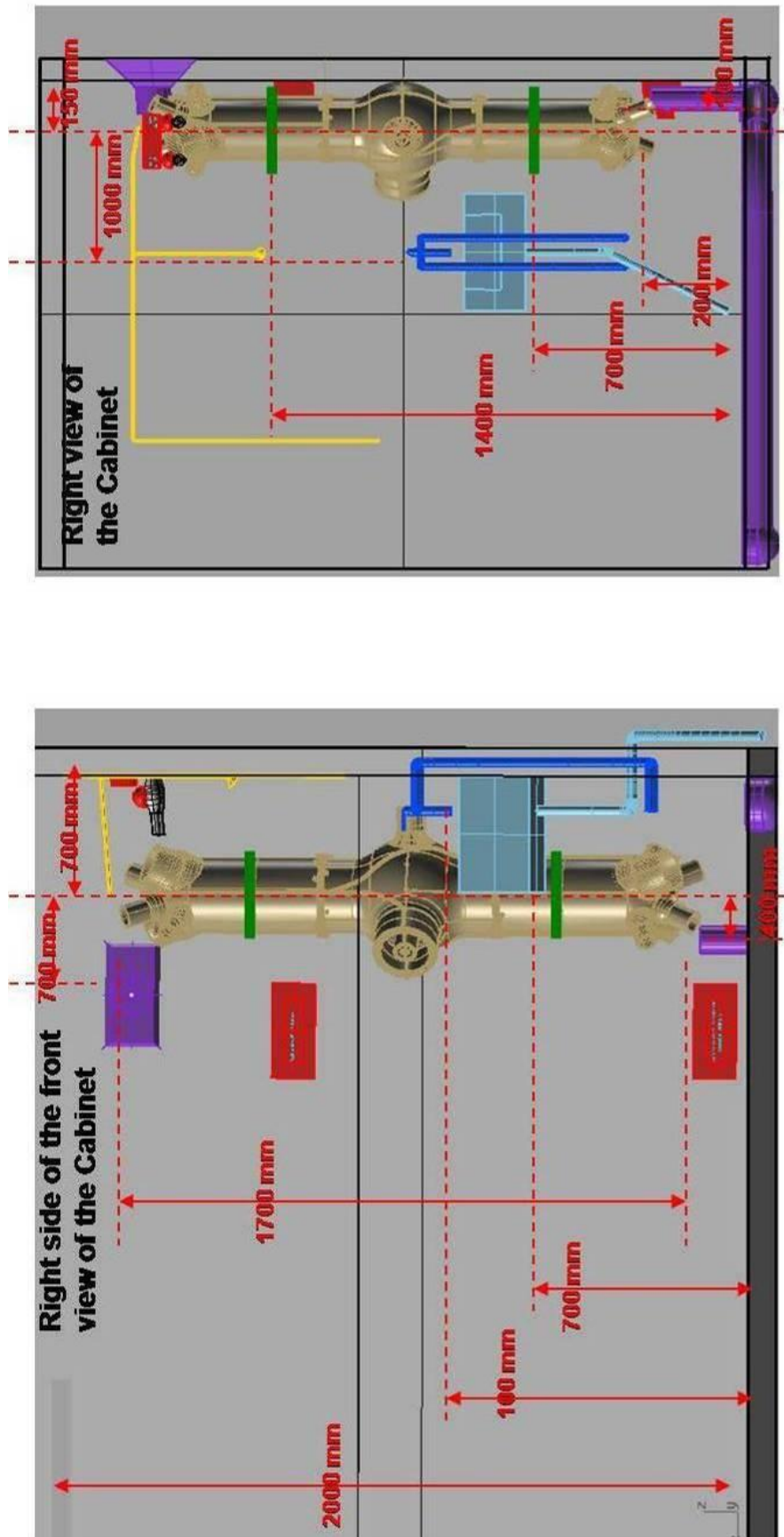

Fig. 4-35: Dimensions and positioning of the MSTs components in the Mock-up [LOU]



## 4.8 WSN Deployment

- **Requirements and BoM:**

- o TRT requirements regarding the wireless sensors (housing, dimensions, installation and location, power supply, server HW and SW, connectivity via Ethernet/Internet/radio, etc.) were specified in § 3.4.
- o All the additional requirements for the WSN deployment have been supplied according to *Table 4-5*.
- o The bill of materials was carefully checked by SEIS' factory quantity surveyor, DRA and TRT to ensure that all the necessary items were considered (*see Appendix IV*).
- o All outdoor and indoor sensors for the Mock-up were purchased by DRA-SEIS after signing an End-User Declaration (EUD), required by Crossbow. Afterwards, the sensors were delivered to TRT (UK) for software installation on sensor platforms and housing.

*Table 4-5: Additional requirements for the WSN deployment [TRT]*

<b>Internet access for:</b>	Access to sensor data from off-site. Software monitoring of hardware/software performance. To collect Internet weather data for reference.
<b>Wired Ethernet network for:</b>	WSN gateways (MIB600) to be connected; otherwise, at least one connection for connecting WSN gateway to LAN. May be difficult as the sensors are placed in awkward area; otherwise, Wi-Fi required. Allowing server machine to be located away from the module Weather station on the roof if it were installed (it isn't).
<b>Mains power supply for:</b>	CO2 sensors. Server machine. Communications module.

- **Installation:**

- o Note that deployment of sensors inside a building must be performed very carefully. Protective cases for the sensor nodes have to be studied to avoid interferences.
- o WSN was deployed throughout the Mock-up (*Fig. 4-36*) and the operational state of WSN infrastructure tested during summer 2010.
- o Only the C&P sensor in the bathroom was not working (it was replaced).
- o Integration of WSN with the BOS was done successfully.



*Fig. 4-36: C&P and HLT wireless sensors fitted in the Mock-up technical ceiling [DRA-SEIS]*

## 4.9 Wiring and net-working

The *Appendix V*<sup>110</sup> details all the connections between the controlling modules and the different inputs (sensors and meters) and outputs (actuators, valves, etc.), as shown on *Fig. 4-37*.

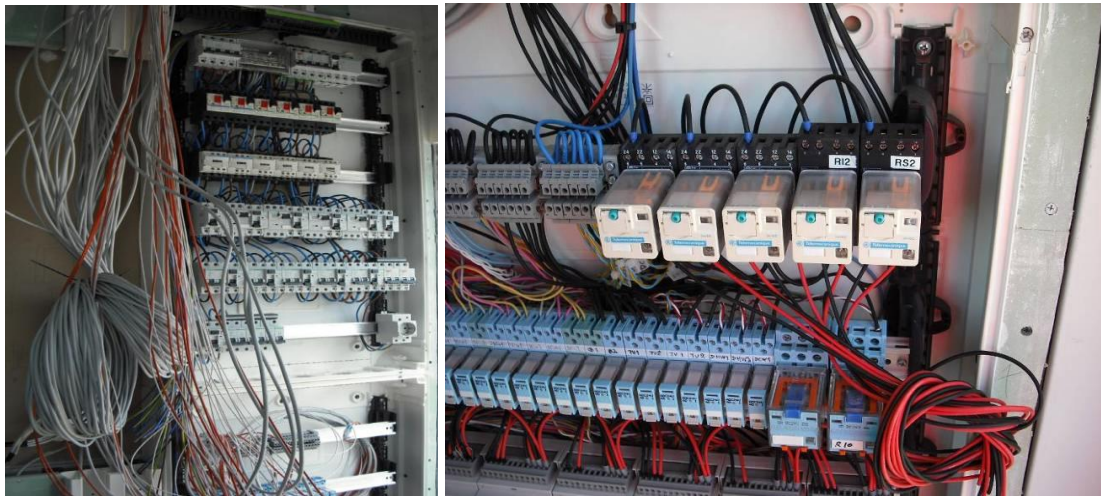

*Fig. 4-37: Relays and controlling modules with the cables pulled from the switchboard [DRA-SEIS]*

This chapter explains the connections made between the sensors, meters and actuators handled by the BOS, and the different gateways deployed for the remote monitoring and control of the building by means of the WSN and the MPTs.

- In the end, the tablet PC is not going to be embedded, but mounted on a structure over the partition wall<sup>111</sup> between the kitchen and the Local-1, facing this room.
  - o Actualization of the Tablet PC interface can be done remotely.
- Regarding the sensors deployed on the façade panels (see §§ 2.2.4 & 3.3.2), some of them broke down during summer 2010, specifically: P-10 Surface Temp1 & 2, P-08 Surface Temp7, P-03 Surface Temp3 and P-02 Surface Temp1.
  - o They were connected to different LON modules, so the reason behind the failure must be the water that entered in the sensors due to heavy rain (there were some summer storms). The manufacturer was contacted to analyze the damaged units and replace them<sup>112</sup>.
- The fluorescent lamps, the electronic ballasts and the switches were installed following the specifications, but the BOS seemed to have problems in handling the output from the ballasts (a 13 V signal): the lamps could be dimmed from intermediate to full lighting, but not totally off.
  - o This was solved by adding intermediate resistances in the circuits for rooms Local-1, 2 and 3 (in the kitchen and the bathroom the lights will have to be switched off manually, but there the integration of the lights and the ECGU is not being tested).

<sup>110</sup> The last version was released as of date 2010-08-23, and includes all the changes made during the commissioning process. There should be no more changes.

<sup>111</sup> Note that this partition wall houses also the control panel and the electrical switchboard.

<sup>112</sup> Any additional information may be of help in the future, such as installation recommendations, technical data, etc., so the problem doesn't repeat in the future. In this case, the failure is not critical because sensors were duplicated precisely foreseeing eventualities like this one, but in a real scale building it would be too expensive to duplicate all the sensors.



## 4.10 Mobile productivity tools

- **Mobile devices** can be any MS Mobile 6 devices with net-working capabilities (preferably with SD/CF memory slot or RS232 connector for the RFID reader).
  - o However, in order to demonstrate the services in a way closest to the commercial deployment it would be best if users could get hold of a durable, industrial Mobile Computer with SD/CF memory slots and/or RS232 connector (9-pin) that could be setup for the demo.
  - o Otherwise, ICOM recommends standard commercial Mobile 6 PDA devices<sup>113</sup>.
  - o Mobile devices require network adapters, one or more of:
    - WiFi: if existent and necessary building servers are not available via public network (i.e. accessible externally).
    - GPRS/UMTS: in case of access to building services from external network.
- **Tags deployment:**
  - o ICOM used active RFID tags as offering more advantages than disadvantages in comparison to best performing passive RFID alternatives.
  - o For simplicity reasons, the same type of tags was used for both positioning and equipment tagging. They are configured to be read at short range, i.e. within a room and across nearest walls.
  - o Regarding the note about “on metal surface” in the datasheets, it means only that the tags are suitable to be fixed on metal surfaces, i.e. antenna will not be shielded out. It does NOT mean that they can be used only on metal surfaces.
  - o As of date 2010-08-16, the tags should have been delivered to ICOM, but they were not. During summer 2010, ICOM performed remote software configuration on the Mock-up server. The issue of time was not very crucial for demo deployment since RFID tags can be quickly placed (glued or screwed). The configuration of the server requires only one hour to associate tag ID with sensors, which need to be deployed prior to placing RFID tags, or other building components.
  - o To speed up the process and make some advance configuration, the location of tags and their IDs were agreed in advance, such that the only thing left was placing (physically) the RFID tags at the pre-defined locations and setting up the ICOM server on the internal building network.
  - o The whole RFID deployment and testing was successfully done in one day prior to I3CON Project demonstration activities.
  - o As a backup, ICOM fixed the Browser application to operate in network-less conditions (i.e. using cached server information) in case of network problems in the building.

---

<sup>113</sup> For example, HP 4700, Dell Axim or HTC TY TN II.

## 5 Measurements Plan for demonstration of R&D results

---

The mock-up was built to test the feasibility (in terms of physical integration and logical interoperability) of the components and systems developed in I3CON and to measure their performance whilst working altogether. The values to be measured and monitored are: water (hot and cold), electricity and energy consumptions; temperature (ambient and surface) and relative humidity degree, both indoor and outdoor; presence; water temperature and flow; CO<sub>2</sub> concentration; and light level (illuminance and glare). This is done by means of a network of sensors, meters and actuators deployed throughout the Mock-up.

- First, some components' suitability for being manufactured and physically integrated within the built environment is validated with the construction of the Mock-up itself and the assembly of such components.
  - o For example, the integration of PCM-enhanced plasterboards: they need to be tested prior to their introduction in full-scale, real-dwelled buildings. Further work is suggested for improving thermal and mechanical properties; if the prototypes can be finally manufactured, they will replace the existing plasterboards in the Mock-up to endure the same performance tests.
  - o PCMs can also be incorporated in bulk, packed in plastic bottles, in the core of GRC Sandwich panels; this was done re-engineering current manufacturing processes.
  - o The modularity of the Sandwich Framex façade is checked with the assembly and disassembly of different external elements, such as PV panels and wooden laminates. This panel typology is also used for developing a vegetated façade and its watering system for the maintenance of the plants.
- For other singular systems, start-up tests are conceived in order to prove:
  - o The delivery of water, air and electricity through the Multi-Service Trunking System.
  - o The water savings through the presence-based recirculation system (making use or remotely-controlled consumption simulations).
  - o The simplicity of the domestic fire extinguishing system
  - o In order to improve the Mock-up envelope design, it is suggested the analysis of thermal bridges using thermographs and to study the acoustical behaviour.
- Finally, in order to assess the thermal performance of the different envelope solutions, compare them, and evaluate the contribution of passive systems to the stabilization of the indoor temperature, it is necessary to define:
  - o The Mock-up boundary conditions.
  - o The different usage scenarios.
  - o The measurements to be carried out in summer, autumn and winter times, and draft a schedule for them.

## 5.1 Constructability

### 5.1.1 PCM-enhanced plasterboards

- Objectives:
  - o To check the ease of assembly, disassembly and substitution of the plasterboards.
- Data to be obtained:
  - o Panels weight and dimensions.
  - o Description, timing and pictures/video of the assembly/disassembly processes.
  - o Photographs of the innermost surface finishing.
- Resources:
  - o Cam recorder and/or camera.
  - o Scale or any other device for weighing.
  - o Staff with drywall construction skills.
  - o Technical documentation (Knauf).
- Measurement times:
  - o During the substitution of the PCM-enhanced plasterboards by conventional ones and vice versa (see scenarios calendar, § 5.4.4).

### 5.1.2 Modularity of the Sandwich Framex façade

- Objectives:
  - o To check the modularity of the Sandwich Framex envelope system, that allows the integration of different external elements such as photovoltaic cells<sup>114</sup>, vegetation, decorative laminates/composites, ventilated ceramics or metal sheets.
  - o To demonstrate that such cladding elements are interchangeable since all of them are supported by the same metallic profiles of the auxiliary Sandwich Framex structure.
- Data to be obtained:
  - o Timing and video/pictures (for proof of concept) of :
    - The assembly of the PV cells over the external frame of façade panel P-03.
    - The eventual disassembly times of the existing cladding for replacement with other elements (e.g. wooden laminates/vegetated panels).
- Resources:
  - o Cam recorder and/or camera.
  - o Factory staff with construction skills.
- Measurement times:
  - o During the assembly/disassembly processes done by specialist workers.

### 5.1.3 Manufacture of a GRC Sandwich panel with PCM packed in the core

- Objectives:
  - o To incorporate PCMs to the core of GRC sandwiches maintaining the panel integrity and ease of manoeuvre with slight changes in the manufacturing process.
  - o To check that the GRC ribs introduced to stiffen the sandwich panel allow the anchoring of the auxiliary metallic frame and that it supports the load imposed by the different external elements (suitability of the Sandwich Framex solution).

---

<sup>114</sup> The objective is measuring neither the annual yield nor the efficiency of the PV cells, but their ease of installation on the Sandwich Framex substructure.

- Data to be obtained:
  - o Description, timing and pictures/video of the manufacturing process.
  - o Curing times for comparison with conventional GRC sandwich ones.
  - o Detailed photographs of the surfaces finishing.
  - o Weights and dimensions of GRC sandwich panels with and without PCMs packed in the core.
  - o Weight of the HDPE bottles (full and empty) in order to calculate the net weight of phase change material within the façade.
  - o 100 ml sample of the PCM to carry out chemical analyses and DSC tests.
  - o Table with all the physical and chemical properties of the façade constituents, e.g. density, specific heat, thermal conductivity, overall thermal resistance, etc.
  - o “As built” drawings including manufacturing steps, bill of materials and mixing proportions, details of the definitive anchoring systems and frame solution, etc.
- Resources:
  - o Cam recorder and/or camera.
  - o Scale or any other device for weighing.
  - o Factory staff with manufacturing skills; staff with technical drawing skills.
  - o Independent specialist laboratory.
  - o Technical documentation (Linpac).
- Measurement times:
  - o During the manufacturing of the new façade panels with PCM at 23 °C (note that the existing ones were produced with a defective batch of PCM).
  - o During the manufacturing of a small sample of GRC Sandwich panels with only one or two PCM bottles but the same thicknesses. Inside this, a temperature sensor will be immersed, being introduced through the bottle cap and sealed afterwards.
  - o Note: a similar small-scale sandwich panel will be produced without the PCM for comparison of the two samples’ thermal behaviour under laboratory conditions. Another sensor may be deployed within the GRC ribs in order to map the thermal gradient along the façade thickness.

#### 5.1.4 Vegetated modules development & installation onto Sandwich Framex

- Objectives:
  - o To track the vegetated modules growing up in a greenhouse/plants nursery, transport, installation and evolution once on vertical position.
  - o To document the different stages, identifying critical points.
  - o To check the improvements in terms of lightness, ease of installation/substitution, and adaptability of the vegetated modules to the façade lay-out in comparison with current commercial solutions (suggested benchmarking in cooperation with Intemper<sup>115</sup>).
- Data to be obtained:
  - o Graphic documentation and description of the growing process in the plants nursery (horizontal position).
  - o Problems identified during transport.
  - o Steps and special cares during the reception of the plants and the storage until final installation.
  - o Graphic documentation and description of the assembly/disassembly on site.
  - o Weight of the vegetated panels, with the cells full of humid substrate and grown plants, and comparison with existing solutions.

---

<sup>115</sup> [www.intemper.com](http://www.intemper.com)

- Resources:
  - o Cam recorder and/or camera.
  - o Scale or any other device for weighing.
  - o Spare vegetated modules/plants.
  - o Researchers from ABIO to follow the growing up at plants nursery.
  - o Cooperation from Intemper to transport the plants from Madrid to Seville.
  - o Factory staff/subcontracted gardener for the installation/care of the vegetated modules (reporting to ABIO-DRA).
- Measurement times:
  - o Growing up at plants nursery (December 2009 –April 2010).
  - o Transport: May 2010.
  - o Installation: June 2010.
  - o Evolution of the plants in vertical position: summer 2010 onwards.

### 5.1.5 Manufacture of improved plasterboard prototype

Note: This is proposed as future research work, since the design of the solution may be subjected to patent registration by ABIO.

- Objectives:
  - o To check the improvements on:
    - Thermal performance (by means of PCM micro-capsules aggregates).
    - Mechanical behaviour (by means of polypropylene fibres reinforcement).
  - o To check the manufacturing viability.
  - o To check the constructability (ease of installation and replacement).
- Data to be obtained:
  - o Weights and dimensions of the plasterboards prototypes.
  - o Table with all the physical and chemical properties of the constituent materials and the final product.
  - o Description, timing and pictures/video of the manufacturing process and the assembly by a specialist worker.
  - o Detailed photographs of the surfaces finishing.
  - o Identification of industrial partner for real production.
- Resources:
  - o Cam recorder and/or camera.
  - o Scale or any other device for weighing.
  - o Staff with manufacturing skills; staff with drywall construction skills.
  - o Independent specialist laboratory for carrying out mechanical and thermal behaviour tests.
  - o Technical documentation (ABIO-BASF).
- Measurement times:
  - o During manufacturing and assembly (if it finally takes place).

## 5.2 Start-up tests for the singular systems

It is taken for granted that the conventional auxiliary systems work well and have been checked, but their functioning is not subject of a R&D report.

A protocol of start-up tests for the singular systems was conceived to demonstrate their functioning to the visitors to the Mock-up and for dissemination purposes.

### 5.2.1 Services delivery through the MSTS

- Water distribution (hot and cold water)
  - o Requires: connection to the standard piping system.
  - o Specific action: opening and closing of the tap showing that the water runs through the appropriate MSTS conduits and discharges into the sink.
  - o Note: a by-pass is included just in case MSTS fails.
- Electricity distribution:
  - o Requires: mains supply
  - o Specific action: switching the lamp on and off.
- Localized distribution of air:
  - o Requires: a fan.
  - o Specific action: switching the fan on and off and checking that there is air flow at the distribution points. This is a YES-NO checking (there is no quantitative flow measurement).

### 5.2.2 Water saving system

- Objectives:
  - o Assessment of the water saving system at different seasons and for different usage scenarios (simulated).
- Data to be obtained:
  - o Water temperature at discharge point.
  - o Waiting time for getting water at desired temperature (multiplied by the water flow, it can be calculated the wasted volume of water).
  - o Energy consumption.
  - o Water consumption.
- Resources:
  - o Water temperature sensor.
  - o Water flow meter.
  - o Electricity meter to calculate the energy consumed to heat the water (note that DHW is also supplied by the solar thermal collector).
  - o Electro-valves controlled by the BOS for remote simulations or by the factory staff for on-site tests.
- Measurement conditions:
  - o Fan-coil units off.
  - o Usage simulations to be done with the water recirculation pump first on and later off, to compare the results with Uponor's data.
  - o The Mock-up BOS can operate the electrovalves for opening/closing the faucets and activating the recirculation pump even when the occupancy sensors are not really activated by somebody's presence (as a back-up plan, it will be done manually in-situ).
- Usage scenarios:



- o Without recirculation and without presence sensor.
- o With recirculation but without presence sensor (recirculation programmed/working all the time).
- o With recirculation triggered by presence sensor.
- Measurement time:
  - o During one day in winter.

### 5.2.3 Fire extinguishing system

- Objectives:
  - o To check system's functionality (adequate performance and water flow).
- Tests and validation:
  - o System try-out.

### 5.2.4 Analysis of thermal bridges throughout the Mock-up envelope

- Objectives:
  - o To evaluate the design, manufacturing and assembly quality of the different façade panels in order to improve the detailing and feedback new designs<sup>116</sup>.
- Data to be obtained:
  - o Evolution of the outdoor ambient temperature and façade surface temperature (T-t curves).
  - o Thermograms.
- Resources.
  - o Ambient and surface temperature sensors.
  - o Thermographic camera<sup>117</sup>.
  - o Specialized SMEs / University departments / Research centres (ABIO, iMat, etc.<sup>118</sup>).
- Measurement conditions:
  - o FCUs and UFH<sup>119</sup> on and off according to a plan to be drafted by specialists.
- Measurement times:
  - o Cold day in winter and hot day in summer to get to know the thermal behaviour in different (extreme) outdoor climate conditions, at coldest/hottest day hour.

### 5.2.5 Acoustical behaviour

- Objective:
  - o To evaluate the acoustical behaviour of the Mock-up envelope as a whole.
  - o To compare the values of specific façade system (Sandwich Framex with PCMs, Sandwich Framex with vegetation, and Sandwich with mineral wool and special finishing pattern) versus conventional SEIS' GRC Stud-frame/Sandwich panels.

---

<sup>116</sup> Further research is suggested in the field of buildings envelope retrofitting technologies (PPP "Energy-efficient Buildings" Economy Recovery Plan 2011 –NMP FP7).

<sup>117</sup> A.k.a. FLIR (Forward Looking Infrared) or just Infrared camera.

<sup>118</sup> [www.abio-upm.org](http://www.abio-upm.org), [www.imat.cat](http://www.imat.cat)

<sup>119</sup> The HVAC systems fitted in the Mock-up are fan-coil units and under-floor radiant heating system, functioning with a solar thermal collector supported by a water-water heat pump.

- o To compare the values obtained under the zone covered by the walkable roofing system versus the zone featuring only the waterproofing layer, in terms both of impact and airborne noise.
- Data to be obtained:
  - o Soundproofing values against airborne noise: standardized level difference between adjacent rooms,  $D_{nT,A}$ :
    - Kitchen – Local-1: tiled wall – bare drywall.
    - Local-1 – Local-2: bare drywalls.
  - o Soundproofing values against airborne noise: standardized level difference between the different envelope systems (floor slab, and different roofing solutions and façade panels),  $D_{2m,nT,Atr}$ :
    - Cast concrete floor slab (incorporating UFH system).
    - Roofing system (waterproofing membrane + puncture-resistant synthetic felt) with and without isolating walkable paving<sup>120</sup>.
    - GRC Stud-frame panel (blind and with 1x1 m window).
    - Sandwich Framex with PCM boxes in the core (blind and with 1x1 m window).
    - Sandwich Framex with vegetated panels (blind and with 1x1 m window).
    - GRC Sandwich with mineral wool filling and indoor special finishing pattern.
  - o Impact insulation class of the horizontal structural components,  $L'_{nT,W}$ :
    - Cast concrete floor slab (incorporating UFH system).
    - Roofing system with and without isolating walkable paving.
  - o Further analysis:
    - Test under lab conditions of the different walling (façade panels and partition walls) and fenestration elements (windows and doors).
    - Comparison with the values given by the “*Herramienta de Ruido*” indicated by the Spanish building standards (CTE).
- Resources:
  - o Specialist subcontractor with the necessary equipment (to be defined).
- Measurements conditions and times:
  - o To be defined by the specialist.

---

<sup>120</sup> Slab of porous concrete over a base of XPS foam.

## 5.3 Thermal performance of the different envelope solutions and passive systems

This assessment is going to be done through a series of periodical measurements detailed in the following chapters.

### 5.3.1 Boundary conditions and thermal insulation

Each one of the façade panels have different U-values, which should be tested under lab conditions. For the design of the heating system, the chosen  $U_{\min}$  has been that corresponding to the climatic zone of Madrid/Seville (the most restrictive one) prescribed in the Spanish standard DB-HE 1.

- U-values (to be compared with the results of the Measurements Plan).
  - o Conventional façade panel (blind wall):  $U = 0.40 \text{ W/m}^2\cdot\text{K}$
  - o Windows: depending on the values of the ECGU and the metalwork<sup>121</sup>.
  - o Floor: thermal insulation achieved by: the concrete slab + EPS foam (4 cm) + mineral wool projected mortar (3cm) + stoneware tiling<sup>122</sup>.
  - o Partition walls: gypsum wallboards  $t = 106 \text{ mm}$  (2 boards x 15 mm of plasterboard + 46 mm of glass fibre + 2 boards x 15 mm of plasterboard). U-values to be confirmed:
    - Between Local-1 – Local-2 and Local-2 – Local-3
    - Kitchen – Local-1: this wall bears the electrical switchboard, the DDC panel, and a tablet PC.
    - Local-3 – Bathroom: bathroom side finished with stoneware tiles  $t = 10 \text{ mm}$ .

### 5.3.2 Comparison of the different rooms envelopes thermal performance

- Objectives:
  - o To assess, in a qualitative way, the thermal performance of the different façade solutions fitted in the Mock-up:
    - Local-1: P-02 & P-10 (conventional GRC Stud-frame with PCM-enhanced plasterboards first and conventional plasterboards later).
    - Local-2: P-03 & P-09 (Sandwich Framex with PCM boxes in the core).
    - Local-3: P-04 & P-08 (Sandwich Framex with vegetated modules as external cladding elements).
- Strategy:
  - o The Mock-up features different façade panels at each one of its rooms. Since the thermal insulation is far from being perfect at floor, roof, and partition walls, it is impossible to know the actual behaviour of each façade panel in itself.
  - o For this reason, each room is equipped with independent fan-coil units for conditioning the indoor environment. If the temperatures are set at a constant value, the same one for each room ( $T_K = T_1 = T_2 = T_3 = T_B$ ), during a certain period, there won't be heat transfer through the partition walls (being both sides at the same temperature, the gradient-driven flow will be negligible).
  - o Hence, there will only be heat transfer through the envelope with the outdoor environment that will be the same one for all the rooms ( $T_{\text{out}}$  can be assumed as the same for the whole building given the small dimensions of the Mock-up).

---

<sup>121</sup> The windows frameworks feature thermal bridge rupture.

<sup>122</sup> Estimated value:  $U = 0.5 \text{ W/m}^2\cdot\text{K}$  (to be confirmed). Improvements by the addition of PCMs to the levelling mortar are subject of further research.

- o In this situation, the energy consumption of each FCU to keep the room temperature at the set value will be indicative of the thermal behaviour of the enclosure system: the less the consumption (measured by means of calorie meters), the better the façade's thermal behaviour.
- Data to be obtained:
  - o Evolution of the outdoor ambient temperature and façade surface temperature (T-t curves).
  - o Evolution of the energy consumption for each FCU.
- Resources:
  - o Outdoor ambient temperature sensor.
  - o Indoor ambient temperature sensors at each room fitted in the same position.
  - o Calorie meters fitted at each FCU.
- Measurement conditions and times:
  - o Temperature data collected every 15 minutes.
  - o A/C set values: 25 °C (summer); 22 °C (winter).
  - o Summer time: 10 weeks; winter time: 6 weeks.

### 5.3.3 Stabilization of the indoor temperature by means of passive systems

This assessment is done considering the Mock-up as a whole.

- Objectives:
  - o To assess the contribution of the passive systems to stabilize the indoor ambient temperature of the Mock-up as a whole.
- Data to be obtained:
  - o Evolution of the outdoor ambient temperature (T-t curves).
  - o Evolution of the Mock-up indoor ambient temperature (T-t curves). This is a mean valued, calculated from the data obtained from each one of the different enclosure systems (see § 5.3.2).
- Resources:
  - o Indoor ambient temperature sensors deployed in kitchen, rooms Local-1, -2 & -3, and bathroom.
  - o Clock-calendar integrated in the BOS.
- Measurement conditions and times:
  - o FCUs and UFH off (free evolution of the Mock-up).
  - o Temperature data collection every 15 minutes.
  - o One month in winter and one month in summer.

## 5.4 Usage scenarios and measurement times

For every measurement of those explained in the following paragraphs, it is interesting to plot the evolution of the temperature with the time (T-t curves).

Each one of the measurement/usage scenarios (identified by the acronym SC-xx) lasts one week, during which data is collected for further analysis.

### 5.4.1 Summer time measurements

- SC-01.** Free evolution with windows closed at night time.
- SC-02.** Free evolution with windows open at night time<sup>123</sup>.
- SC-03.** Energy consumptions with all the rooms conditioned at the same temperature 24 h.
- SC-04.** Energy consumptions with all the rooms conditioned at the same temperature (during the day) and the HVAC off and open windows for night ventilation (from 10 pm to 10 am).
- SC-05.** Energy consumption of the FCU installed in room Local-1 with the ECGU working, for comparison with the consumption when the ECGU is not working (SC-03).
- SC-06.** Free evolution of the room Local-1, with closed windows, after conventional plasterboards have been fitted, for comparison with SC-01 (PCM-enhanced plasterboards).
- SC-07.** Free evolution of the room Local-1, with night ventilation, after conventional plasterboards have been fitted, for comparison with SC-02 (PCM-enhanced plasterboards).
- SC-08.** Energy consumptions with all the rooms conditioned at the same temperature 24 h, after conventional plasterboards have been fitted, for comparison with SC-03 (PCM-enhanced plasterboards).
- SC-09.** Energy consumptions with all the rooms conditioned at the same temperature (during the day) and the HVAC off and open windows for night ventilation (from 10 pm to 10 am), after conventional plasterboards have been fitted, for comparison with SC-04 (PCM-enhanced plasterboards).
- SC-10.** Energy consumption of the FCU installed in room Local-1 with the ECGU working, for comparison with the consumption when the ECGU is not working (SC-07), and for comparison with the consumption when there were PCM-enhanced plasterboards and the ECGU was working (SC-05).

---

<sup>123</sup> The windows cannot be operated remotely, but the Mock-up is located in the yard of a factory under permanent surveillance, so the security staff can open the windows at the specified time (e.g. 10 pm).

Table 5-1: Scenarios for periodical measurements at summer time [DRA]

Scenario	FCUs	UFH	ECGU	Windows at night	Local-1 Plasterboards
SC-01	OFF	OFF	OFF	Closed	PCM-enhanced
SC-02	OFF	OFF	OFF	Open	PCM-enhanced
SC-03	ON	OFF	OFF	Closed	PCM-enhanced
SC-04	ON(d)/OFF(n)	OFF	OFF	Open	PCM-enhanced
SC-05	ON	OFF	ON <sup>124</sup>	Closed	PCM-enhanced
SC-06	OFF	OFF	OFF	Closed	Conventional
SC-07	OFF	OFF	OFF	Open	Conventional
SC-08	ON	OFF	OFF	Closed	Conventional
SC-09	ON(d)/OFF(n)	OFF	OFF	Open	Conventional
SC-10	ON	OFF	ON	Closed	Conventional

#### 5.4.2 Autumn time measurements

Windows will be closed 24 h.

SC-11. Free evolution.

SC-12. Energy consumptions with all the rooms conditioned at the same temperature 24 h.

Table 5-2: Scenarios for periodical measurements at autumn time [DRA]

Scenario	FCUs	UFH	ECGU	Windows at night	Local-1 Plasterboards
SC-11	OFF	OFF	OFF	Closed	Conventional
SC-12	ON	OFF	OFF	Closed	Conventional

#### 5.4.3 Winter time measurements

Windows will be closed 24 h.

SC-13. Free evolution of the Mock-up with all the systems off, and conventional plasterboards.

SC-14. Energy consumptions with all the rooms conditioned at the same temperature 24 h.

SC-15. Performance of the under-floor radiant heating system<sup>125</sup>.

SC-16. Free evolution of the Mock-up with all the systems off, and PCM-enhanced plasterboards, for comparison with SC-13.

SC-17. With all the rooms conditioned at the same temperature, measurement of the energy consumption of the FCU in room Local-1, for comparison with its consumption during SC-14.

SC-18. Combined effect of the UFH together with the PCM-enhanced plasterboards, for comparison with the energy consumptions during SC-15.

<sup>124</sup> ECGU on, with glazing state according to the indoor light level (measured in lux).

<sup>125</sup> Additional surface temperature sensors would be necessary at floor level.



Table 5-3: Scenarios for periodical measurements; winter time [DRA]

Scenario	FCUs	UFH	ECGU	Windows at night	Local-1 Plasterboards
SC-13	OFF	OFF	OFF	Closed	Conventional
SC-14	ON	OFF	OFF	Closed	Conventional
SC-15	OFF	ON	OFF	Closed	Conventional
SC-16	OFF	OFF	OFF	Closed	PCM-enhanced
SC-17	ON	OFF	OFF	Closed	PCM-enhanced
SC-18	OFF	ON	OFF	Closed	PCM-enhanced

#### 5.4.4 Calendar

The schedules shown on Table 5-4,

Table 5-5 and Table 5-6 are speculative dates for the different measurements scenarios at summer, autumn and winter times. A more detailed programming is detailed in the MPP file gathered in Appendix II.

Table 5-4: Summer time measurements schedule (June-July-August-September 2011) [DRA]

Scenario	Monday	Tuesday	Wednesday	Thursday	Friday	Saturday	Sunday
Summer Start-up	20-Jun	21-Jun	22-Jun	23-Jun	24-Jun	25-Jun	26-Jun
SC-01	27-Jun	28-Jun	29-Jun	30-Jun	1-Jul	2-Jul	3-Jul
SC-02	4-Jul	5-Jul	6-Jul	7-Jul	8-Jul	9-Jul	10-Jul
SC-03	11-Jul	12-Jul	13-Jul	14-Jul	15-Jul	16-Jul	17-Jul
SC-04	18-Jul	19-Jul	20-Jul	21-Jul	22-Jul	23-Jul	24-Jul
SC-05	25-Jul	26-Jul	27-Jul	28-Jul	29-Jul Knauf Placo →	30-Jul	31-Jul
SC-06	1-Aug	2-Aug	3-Aug	4-Aug	5-Aug	6-Aug	7-Aug
SC-07	8-Aug	9-Aug	10-Aug	11-Aug	12-Aug	13-Aug	14-Aug
SC-08	15-Aug	16-Aug	17-Aug	18-Aug	19-Aug	20-Aug	21-Aug
SC-09	22-Aug	23-Aug	24-Aug	25-Aug	26-Aug	27-Aug	28-Aug
SC-10	29-Aug	30-Aug	31-Aug	1-Sep	2-Sep	3-Sep	4-Sep
Slack week	5-Sep	6-Sep	7-Sep	8-Sep	9-Sep	10-Sep	11-Sep

Table 5-5: Autumn time measurements schedule (October-November 2011) [DRA]

Scenario	Monday	Tuesday	Wednesday	Thursday	Friday	Saturday	Sunday
Autumn Start-up	17-Oct	18-Oct	19-Oct	20-Oct	21-Oct	22-Oct	23-Oct
SC-11	24-Oct	25-Oct	26-Oct	27-Oct	28-Oct	29-Oct	30-Oct
SC-12	31-Oct	1-Nov	2-Nov	3-Nov	4-Nov	5-Nov	6-Nov
Slack week	7-Nov	8-Nov	9-Nov	10-Nov	11-Nov	12-Nov	13-Nov

Table 5-6: Winter time measurements schedule (January-February 2012) [DRA]

Scenario	Monday	Tuesday	Wednesday	Thursday	Friday	Saturday	Sunday
Winter Start-up	2-Jan	3-Jan	4-Jan	5-Jan	6-Jan	7-Jan	8-Jan
SC-13	9-Jan	10-Jan	11-Jan	12-Jan	13-Jan	14-Jan	15-Jan
SC-14	16-Jan	17-Jan	18-Jan	19-Jan	20-Jan	21-Jan	22-Jan
SC-15	23-Jan	24-Jan	25-Jan	26-Jan	27-Jan Placo Knauf →	28-Jan	29-Jan
SC-16	30-Jan	31-Jan	1-Feb	2-Feb	3-Feb	4-Feb	5-Feb
SC-17	6-Feb	7-Feb	8-Feb	9-Feb	10-Feb	11-Feb	12-Feb
SC-18	13-Feb	14-Feb	15-Feb	16-Feb	17-Feb	18-Feb	19-Feb
Slack week	20-Feb	21-Feb	22-Feb	23-Feb	24-Feb	25-Feb	26-Feb

Note: the Mock-up auxiliary systems were not working for carrying out the measurements plan in summer 2010; that's why it will take place during summer 2011. All the measurements periods are allocated a week for the start-up (adjustment of metering devices, etc.) and a slack week to catch up in the event of a disruption in the measuring activities, e.g. breakdown of the control system, or holidays.

The measurements plan is presently being carried out and therefore the conclusions on performance will not be published until 2012. They will be included in the *Appendix 6.2.6*. Nevertheless, there are already very interesting conclusions regarding manufacturing of components and integration of systems, gathered in § 6.

## 6 Conclusions

*Table 6-1* assesses the degree of achievement of the targets set in the definition of the general objectives for this PFC in § 1.1.

As part of the I3CON Project, the design and construction of the Mock-up fulfilled the objectives stated in the I3CON DoW [08] and presented in the scenarios and plans for demonstrations [09], which were described in the introduction to this PFC (§ 1.2)

The design approach of the Mock-up has been performance-based, i.e. every decision has been taken bearing in mind the stakeholders' requirements and performance metrics developed in the I3CON Project Work Packages WP1 and WP2, respectively. Engineering services like those described throughout I3CON WP5 can give support to new business models proposed in WP2 (*outlined in § 1.3.3*), taking advantage of the technology implemented and tested in the Mock-up.

The Mock-up demonstrator feeds from the results of I3CON WP3 and WP4: Building operating system, Wireless sensor network, Envelope system, Electro-chromic glazing, and installation pathways –i.e., Multi-service trunking system and Piping, Water-saving and Fire-extinguishing systems. The use of the Building services model and the Ambient user interfaces (i.e. Mobile productivity tools) is also demonstrated in the Mock-up. An overview of these components and systems is given in § 6.1.

Throughout the evolution of the project, many issues were considered and subjected to technical discussions. Some of them were discarded and others were suggested for further research outside the scope of this project, whilst others remain pending for schedule reasons (*see § 6.2*).

*Table 6-1: General objectives of this PFC; Assessment [RSL]*

Objective	Assessment
1) Application of new production concepts such as Mass Customization through the use of a Design For Manufacturing, Logistics and Assembly (DFMLA) approach, Computer-Aided Design/Manufacturing (CAD/CAM) tools and Off-Site Manufacturing (OSM).	Modular configuration of the different components and systems, most of them in an open architecture, allows the designer to tailor the project to the specific requirements of the final user. In this case, the specifications were intended to allow the comparison between the commercial products and the innovative solutions developed in I3CON. The ultimate aim was to incorporate some of them to the industrial production line, so issues such as cost and sustainability were addressed. The designs were done bearing in mind the manufacturing processes, the logistics involved and the assembly/disassembly issues, and were fed back with the learning of the first prototypes fitted in the Mock-up.
2) Fitting of I3CON Project demonstrations of physical prototypes (elements, components, systems) and manufacturing processes i.e. proven manufacturability.	Development of new façade concept and manufacturing of prototypes by re-engineering current production processes. Integration of electro-chromic glazing. Fitting of built-in piping system for easy renewal. Fitting of domestic water saving and fire extinguishing systems. Fitting of under-floor heating. Manufacturing and installation of the Multi-Services Trunking System.
3) To maintain the level and (ideally) progress beyond the SotA in terms of Industrialisation, Integration, and Intelligence (“I3”).	All the innovations developed in the I3CON Project were incorporated in one or more of the demonstrations activities (virtual, Mock-up or real building). In the case of the Mock-up, some issues that were considered of interest and suggested for further research go, indeed, deeper in the three “Is” of the project.

<p>4.1) Coverage of building stakeholders' requirements.</p> <p>4.2) Promote the involvement of SMEs and bring the gap between academic research and industrial development.</p> <p>4.3) Dissemination/impact degree of the R&amp;D results. Exploitation potential of the project results.</p> <p>4.4) SMART Validation.</p>	<p>Stakeholders' requirements are covered in great degree, especially end users' ones. Most of the RTD results regarding production are implemented in the Mock-up, giving visibility and value.</p> <p>The involvement of medium sized enterprises is noticeable especially as technology providers and bespoke manufactured products. As a collaborative project, it was combined the expertise and know-how in the construction industry of the companies with the research methodology and innovative approach of the university. Feedback between academic and industrial fields.</p> <p>Technology monitoring was incorporated to the day-to-day work, helping to identify innovation issues and to gather the learning of singular works for a greater awareness within the company, combined with continuous update of the state-of-the-art, attendance to congresses and trade fairs, etc. The Mock-up is a test-bed for assessing the performance of the new components working altogether; if the results proved to be successful, they could be integrated in SEIS' prefabricated modules, new buildings or renovation works as value-adding features.</p> <p>The results are specific and will be able to be assessed after the measurements plan has been carried out. Because some of the I3CON objectives were not achievable, the Mock-up which configures the core of this PFC tried to rationalize and be more realistic (the Mock-up was constructed for those results that were not mature enough for being implemented in dwelled buildings). Some of the results are demonstrated by the construction of the Mock-up itself, which can be visited and all the relevant information is available (and tangible) in this PFC and its appendixes.</p>
---	---

## 6.1 Developed components and systems overview

In the introduction to this PFC (§ 1.4), the specific objectives and partners' specifications about *what* and *how* was going to be done in this project (regarding the different components and systems developed in I3CON and implemented in the Mock-up) were presented. After the production and assembly of the components and the design and integration of the systems, next an overview is given about the problems addressed, the target group, the technology and business environment, the objectives, the human and computer actors, the roles & responsibilities, a description of the scenario, the maturity of the result, and where to obtain further information (see Table 6-2 to Table 6-8).

Table 6-2: Facade System overview [DRA]

<input checked="" type="checkbox"/> Product; <input type="checkbox"/> Service; <input type="checkbox"/> Process; <input type="checkbox"/> Other																					
<b>Problem addressed:</b>	Prefabricated façade elements are rarely adapted to the required performance parameters of customers																				
<b>Target group:</b>	<table border="0"> <tr> <td><input checked="" type="checkbox"/> Technology provider;</td> <td><input checked="" type="checkbox"/> Site installation;</td> </tr> <tr> <td><input type="checkbox"/> Designer;</td> <td><input type="checkbox"/> Client / user;</td> </tr> <tr> <td><input checked="" type="checkbox"/> Construction / developer;</td> <td><input checked="" type="checkbox"/> FM &amp; service provider;</td> </tr> <tr> <td><input checked="" type="checkbox"/> Manufacturer;</td> <td><input type="checkbox"/> Research institute;</td> </tr> <tr> <td><input checked="" type="checkbox"/> System integrator;</td> <td><input type="checkbox"/> University;</td> </tr> <tr> <td><input checked="" type="checkbox"/> System supplier;</td> <td><input type="checkbox"/> SME.</td> </tr> </table>	<input checked="" type="checkbox"/> Technology provider;	<input checked="" type="checkbox"/> Site installation;	<input type="checkbox"/> Designer;	<input type="checkbox"/> Client / user;	<input checked="" type="checkbox"/> Construction / developer;	<input checked="" type="checkbox"/> FM & service provider;	<input checked="" type="checkbox"/> Manufacturer;	<input type="checkbox"/> Research institute;	<input checked="" type="checkbox"/> System integrator;	<input type="checkbox"/> University;	<input checked="" type="checkbox"/> System supplier;	<input type="checkbox"/> SME.								
<input checked="" type="checkbox"/> Technology provider;	<input checked="" type="checkbox"/> Site installation;																				
<input type="checkbox"/> Designer;	<input type="checkbox"/> Client / user;																				
<input checked="" type="checkbox"/> Construction / developer;	<input checked="" type="checkbox"/> FM & service provider;																				
<input checked="" type="checkbox"/> Manufacturer;	<input type="checkbox"/> Research institute;																				
<input checked="" type="checkbox"/> System integrator;	<input type="checkbox"/> University;																				
<input checked="" type="checkbox"/> System supplier;	<input type="checkbox"/> SME.																				
<b>Technology and business:</b>	Usage of glass fibre reinforced concrete in the pre-fabrication of performance based facade elements. Integration with other building components and the building automation system.																				
<b>Objectives:</b>	Improvement of current pre-fabricated façade elements and integration with other building components and the building automation system.																				
<b>Human actors:</b>	-																				
<b>Computer actors:</b>	Depending on the level of integration with the building automation system.																				
<b>Roles &amp; Responsibilities:</b>	-																				
<b>Scenario Description:</b>	Prefabrication of performance based façade elements based on customer requirements.																				
<b>Maturity of the result:</b>	<table border="1"> <tr> <td colspan="5">Research</td> <td colspan="5">Market</td> </tr> <tr> <td></td><td></td><td></td><td></td><td></td> <td></td><td></td><td></td><td></td><td></td> </tr> </table>	Research					Market														
Research					Market																
<b>More information:</b>	[15]																				

Table 6-3: Electrochromic Glazing overview [DRA]

<input checked="" type="checkbox"/> Product; <input type="checkbox"/> Service; <input type="checkbox"/> Process; <input type="checkbox"/> Other	
<b>Problem addressed:</b>	Controlled shading that is integrated within windows and the building operation system

<b>Target group:</b>	<input checked="" type="checkbox"/> Technology provider; <input type="checkbox"/> Designer; <input checked="" type="checkbox"/> Construction / developer; <input type="checkbox"/> Manufacturer; <input checked="" type="checkbox"/> System integrator; <input checked="" type="checkbox"/> System supplier;	<input checked="" type="checkbox"/> Site installation; <input type="checkbox"/> Client / user; <input type="checkbox"/> FM & service provider; <input type="checkbox"/> Research institute; <input type="checkbox"/> University; <input type="checkbox"/> SME.										
<b>Technology and business:</b>	Building operation system and availability of low voltage power supply for the control of electrochromic windows											
<b>Objectives:</b>	Increasing comfort and energy savings. Designs can incorporate manual or automatic actuation through devices such as rheostats, thermostats, photocells, etc. Several electrochromic technologies are under study, including a design using electrically conductive layers of film that exchange ions when a voltage (or negative voltage) is applied.											
<b>Human actors:</b>	Building operator.											
<b>Computer actors:</b>	Building automation system, HVAC, sensors.											
<b>Roles &amp; Responsibilities:</b>	-											
<b>Scenario Description:</b>	Single application, Integration in existing building models											
<b>Maturity of the result:</b>	<div style="display: flex; justify-content: space-between; align-items: center;"> <span>Research</span> <span>Market</span> </div> <table border="1" style="width: 100%; height: 20px; margin-top: 5px;"> <tr> <td style="width: 12.5%;"></td> <td style="width: 12.5%;"></td> <td style="width: 12.5%;"></td> <td style="width: 12.5%;"></td> <td style="width: 12.5%; background-color: #cccccc;"></td> <td style="width: 12.5%; background-color: #cccccc;"></td> <td style="width: 12.5%; background-color: #cccccc;"></td> <td style="width: 12.5%; background-color: #cccccc;"></td> <td style="width: 12.5%;"></td> <td style="width: 12.5%;"></td> </tr> </table>											
<b>More information:</b>	[43] & [44]											

Table 6-4: Water Saving System overview [DRA]

<input checked="" type="checkbox"/> Product; <input type="checkbox"/> Service; <input type="checkbox"/> Process; <input type="checkbox"/> Other		
<b>Problem addressed:</b>	Heated water gets only to the tap with a certain delay. This leads to a waste of water and heating energy.	
<b>Target group:</b>	<input checked="" type="checkbox"/> Technology provider; <input checked="" type="checkbox"/> Designer; <input checked="" type="checkbox"/> Construction / developer; <input type="checkbox"/> Manufacturer; <input checked="" type="checkbox"/> System integrator; <input checked="" type="checkbox"/> System supplier;	<input checked="" type="checkbox"/> Site installation; <input type="checkbox"/> Client / user; <input checked="" type="checkbox"/> FM & service provider; <input type="checkbox"/> Research institute; <input type="checkbox"/> University; <input type="checkbox"/> SME.
<b>Technology and business:</b>	Intelligent hot water recirculation device through ultimate plumbing system.	
<b>Objectives:</b>	Energy and water savings through reduction of "time to hot water"	
<b>Human actors:</b>	User, Building operator, Facility manager	
<b>Computer actors:</b>	The system uses a pump, which is user activated by a button or a motion sensor located near the plumbing fixture.	
<b>Roles &amp; Responsibilities:</b>	It is important to have in mind the singularity of a construction project, and therefore the singularity of the manufacturing/ installation of a tap water system.	



<b>Scenario Description:</b>	Uponor plumbing system “D’MAND” provides hot water quickly while saving energy and water																								
<b>Maturity of the result:</b>	<table style="width: 100%; border-collapse: collapse;"> <tr> <td style="text-align: center; width: 50%;">Research</td> <td style="text-align: center; width: 50%;">Market</td> </tr> <tr> <td style="text-align: center;"> <table border="1" style="width: 100%; height: 20px;"> <tr> <td style="width: 12.5%;"></td> <td style="width: 12.5%;"></td> <td style="width: 12.5%;"></td> <td style="width: 12.5%;"></td> <td style="width: 12.5%;"></td> <td style="width: 12.5%;"></td> <td style="width: 12.5%;"></td> <td style="width: 12.5%;"></td> <td style="width: 12.5%;"></td> <td style="width: 12.5%;"></td> </tr> </table> </td> <td style="text-align: center;"> <table border="1" style="width: 100%; height: 20px;"> <tr> <td style="width: 12.5%;"></td> <td style="width: 12.5%;"></td> <td style="width: 12.5%;"></td> <td style="width: 12.5%;"></td> <td style="width: 12.5%;"></td> <td style="width: 12.5%;"></td> <td style="width: 12.5%;"></td> <td style="width: 12.5%;"></td> <td style="width: 12.5%;"></td> <td style="width: 12.5%;"></td> </tr> </table> </td> </tr> </table>	Research	Market	<table border="1" style="width: 100%; height: 20px;"> <tr> <td style="width: 12.5%;"></td> <td style="width: 12.5%;"></td> <td style="width: 12.5%;"></td> <td style="width: 12.5%;"></td> <td style="width: 12.5%;"></td> <td style="width: 12.5%;"></td> <td style="width: 12.5%;"></td> <td style="width: 12.5%;"></td> <td style="width: 12.5%;"></td> <td style="width: 12.5%;"></td> </tr> </table>											<table border="1" style="width: 100%; height: 20px;"> <tr> <td style="width: 12.5%;"></td> <td style="width: 12.5%;"></td> <td style="width: 12.5%;"></td> <td style="width: 12.5%;"></td> <td style="width: 12.5%;"></td> <td style="width: 12.5%;"></td> <td style="width: 12.5%;"></td> <td style="width: 12.5%;"></td> <td style="width: 12.5%;"></td> <td style="width: 12.5%;"></td> </tr> </table>										
Research	Market																								
<table border="1" style="width: 100%; height: 20px;"> <tr> <td style="width: 12.5%;"></td> <td style="width: 12.5%;"></td> <td style="width: 12.5%;"></td> <td style="width: 12.5%;"></td> <td style="width: 12.5%;"></td> <td style="width: 12.5%;"></td> <td style="width: 12.5%;"></td> <td style="width: 12.5%;"></td> <td style="width: 12.5%;"></td> <td style="width: 12.5%;"></td> </tr> </table>											<table border="1" style="width: 100%; height: 20px;"> <tr> <td style="width: 12.5%;"></td> <td style="width: 12.5%;"></td> <td style="width: 12.5%;"></td> <td style="width: 12.5%;"></td> <td style="width: 12.5%;"></td> <td style="width: 12.5%;"></td> <td style="width: 12.5%;"></td> <td style="width: 12.5%;"></td> <td style="width: 12.5%;"></td> <td style="width: 12.5%;"></td> </tr> </table>														
<b>More information:</b>	-																								

Table 6-5: Multi-Services Trunking System overview [DRA]

<input checked="" type="checkbox"/> Product; <input type="checkbox"/> Service; <input type="checkbox"/> Process; <input type="checkbox"/> Other																									
<b>Problem addressed:</b>	Currently, different trunking systems are separated in buildings (hot/cold water, electricity, air, networks).																								
<b>Target group:</b>	<table style="width: 100%; border-collapse: collapse;"> <tr> <td style="width: 50%; vertical-align: top;"> <input checked="" type="checkbox"/> Technology provider;  <input checked="" type="checkbox"/> Designer;  <input checked="" type="checkbox"/> Construction / developer;  <input type="checkbox"/> Manufacturer;  <input checked="" type="checkbox"/> System integrator;  <input checked="" type="checkbox"/> System supplier;         </td> <td style="width: 50%; vertical-align: top;"> <input checked="" type="checkbox"/> Site installation;  <input type="checkbox"/> Client / user;  <input checked="" type="checkbox"/> FM &amp; service provider;  <input checked="" type="checkbox"/> Research institute;  <input checked="" type="checkbox"/> University;  <input type="checkbox"/> SME.         </td> </tr> </table>	<input checked="" type="checkbox"/> Technology provider; <input checked="" type="checkbox"/> Designer; <input checked="" type="checkbox"/> Construction / developer; <input type="checkbox"/> Manufacturer; <input checked="" type="checkbox"/> System integrator; <input checked="" type="checkbox"/> System supplier;	<input checked="" type="checkbox"/> Site installation; <input type="checkbox"/> Client / user; <input checked="" type="checkbox"/> FM & service provider; <input checked="" type="checkbox"/> Research institute; <input checked="" type="checkbox"/> University; <input type="checkbox"/> SME.																						
<input checked="" type="checkbox"/> Technology provider; <input checked="" type="checkbox"/> Designer; <input checked="" type="checkbox"/> Construction / developer; <input type="checkbox"/> Manufacturer; <input checked="" type="checkbox"/> System integrator; <input checked="" type="checkbox"/> System supplier;	<input checked="" type="checkbox"/> Site installation; <input type="checkbox"/> Client / user; <input checked="" type="checkbox"/> FM & service provider; <input checked="" type="checkbox"/> Research institute; <input checked="" type="checkbox"/> University; <input type="checkbox"/> SME.																								
<b>Technology and business:</b>	Additive manufacturing methods through integration by multi-services trunking.																								
<b>Objectives:</b>	Integration of different trunking systems in one integrated multi-trunking system. This is enabled by the usage of additive manufacturing technologies.																								
<b>Human actors:</b>	-																								
<b>Computer actors:</b>	-																								
<b>Roles &amp; Responsibilities:</b>	Support of the building operator, integration of different installation companies.																								
<b>Scenario Description:</b>	Integrated installation of all ductwork in a built environment through the multi-trunking system.																								
<b>Maturity of the result:</b>	<table style="width: 100%; border-collapse: collapse;"> <tr> <td style="text-align: center; width: 50%;">Research</td> <td style="text-align: center; width: 50%;">Market</td> </tr> <tr> <td style="text-align: center;"> <table border="1" style="width: 100%; height: 20px;"> <tr> <td style="width: 12.5%;"></td> <td style="width: 12.5%;"></td> <td style="width: 12.5%;"></td> <td style="width: 12.5%;"></td> <td style="width: 12.5%;"></td> <td style="width: 12.5%;"></td> <td style="width: 12.5%;"></td> <td style="width: 12.5%;"></td> <td style="width: 12.5%;"></td> <td style="width: 12.5%;"></td> </tr> </table> </td> <td style="text-align: center;"> <table border="1" style="width: 100%; height: 20px;"> <tr> <td style="width: 12.5%;"></td> <td style="width: 12.5%;"></td> <td style="width: 12.5%;"></td> <td style="width: 12.5%;"></td> <td style="width: 12.5%;"></td> <td style="width: 12.5%;"></td> <td style="width: 12.5%;"></td> <td style="width: 12.5%;"></td> <td style="width: 12.5%;"></td> <td style="width: 12.5%;"></td> </tr> </table> </td> </tr> </table>	Research	Market	<table border="1" style="width: 100%; height: 20px;"> <tr> <td style="width: 12.5%;"></td> <td style="width: 12.5%;"></td> <td style="width: 12.5%;"></td> <td style="width: 12.5%;"></td> <td style="width: 12.5%;"></td> <td style="width: 12.5%;"></td> <td style="width: 12.5%;"></td> <td style="width: 12.5%;"></td> <td style="width: 12.5%;"></td> <td style="width: 12.5%;"></td> </tr> </table>											<table border="1" style="width: 100%; height: 20px;"> <tr> <td style="width: 12.5%;"></td> <td style="width: 12.5%;"></td> <td style="width: 12.5%;"></td> <td style="width: 12.5%;"></td> <td style="width: 12.5%;"></td> <td style="width: 12.5%;"></td> <td style="width: 12.5%;"></td> <td style="width: 12.5%;"></td> <td style="width: 12.5%;"></td> <td style="width: 12.5%;"></td> </tr> </table>										
Research	Market																								
<table border="1" style="width: 100%; height: 20px;"> <tr> <td style="width: 12.5%;"></td> <td style="width: 12.5%;"></td> <td style="width: 12.5%;"></td> <td style="width: 12.5%;"></td> <td style="width: 12.5%;"></td> <td style="width: 12.5%;"></td> <td style="width: 12.5%;"></td> <td style="width: 12.5%;"></td> <td style="width: 12.5%;"></td> <td style="width: 12.5%;"></td> </tr> </table>											<table border="1" style="width: 100%; height: 20px;"> <tr> <td style="width: 12.5%;"></td> <td style="width: 12.5%;"></td> <td style="width: 12.5%;"></td> <td style="width: 12.5%;"></td> <td style="width: 12.5%;"></td> <td style="width: 12.5%;"></td> <td style="width: 12.5%;"></td> <td style="width: 12.5%;"></td> <td style="width: 12.5%;"></td> <td style="width: 12.5%;"></td> </tr> </table>														
<b>More information:</b>	[14]																								

Table 6-6: Building Control System overview [DRA]

<input checked="" type="checkbox"/> Product; <input type="checkbox"/> Service; <input type="checkbox"/> Process; <input type="checkbox"/> Other	
<b>Problem addressed:</b>	Building control systems are fragmented and relatively difficult to use or to maintain.

<b>Target group:</b>	<input checked="" type="checkbox"/> Technology provider; <input type="checkbox"/> Designer; <input checked="" type="checkbox"/> Construction / developer; <input type="checkbox"/> Manufacturer; <input checked="" type="checkbox"/> System integrator; <input checked="" type="checkbox"/> System supplier;	<input checked="" type="checkbox"/> Site installation; <input type="checkbox"/> Client / user; <input checked="" type="checkbox"/> FM & service provider; <input type="checkbox"/> Research institute; <input type="checkbox"/> University; <input type="checkbox"/> SME.										
<b>Technology &amp; business:</b>	Integration of different building automation system within a network.											
<b>Objectives:</b>	Integrate all building automation systems into one building control system for operators and users.											
<b>Human actors:</b>	User, Building operator, Facility manager											
<b>Computer actors:</b>	Building operation server is necessary to integrate building automation systems.											
<b>Roles &amp; Responsibilities:</b>	Support of the building operator.											
<b>Scenario Description:</b>	Integration of the building control system into built environments to centrally control all different building automation systems through several interfaces (Internet, mobile device, decentralised switches).											
<b>Maturity of the result:</b>	<div style="display: flex; justify-content: space-between; align-items: center;"> <span>Research</span> <span>Market</span> </div> <table border="1" style="width: 100%; height: 20px; margin-top: 5px;"> <tr> <td style="width: 12.5%;"></td> <td style="width: 12.5%;"></td> <td style="width: 12.5%;"></td> <td style="width: 12.5%;"></td> <td style="width: 12.5%;"></td> <td style="width: 12.5%;"></td> <td style="width: 12.5%;"></td> <td style="width: 12.5%;"></td> <td style="width: 12.5%;"></td> <td style="width: 12.5%;"></td> </tr> </table>											
<b>More information:</b>	[54]											

Table 6-7: Sensor Network overview [DRA]

<input checked="" type="checkbox"/> Product; <input type="checkbox"/> Service; <input type="checkbox"/> Process; <input type="checkbox"/> Other		
<b>Problem addressed:</b>	Building automation can only partly react to conditions in the building as this is only rarely measured or integrated in building automation.	
<b>Target group:</b>	<input checked="" type="checkbox"/> Technology provider; <input type="checkbox"/> Designer; <input checked="" type="checkbox"/> Construction / developer; <input type="checkbox"/> Manufacturer; <input checked="" type="checkbox"/> System integrator; <input checked="" type="checkbox"/> System supplier;	<input checked="" type="checkbox"/> Site installation; <input checked="" type="checkbox"/> Client / user; <input checked="" type="checkbox"/> FM & service provider; <input type="checkbox"/> Research institute; <input type="checkbox"/> University; <input type="checkbox"/> SME.
<b>Technology &amp; business:</b>	Wireless sensor network for building management purposes	
<b>Objectives:</b>	Monitoring and measurement of building performance and integration in the building automation system.	
<b>Human actors:</b>	User, building operator	
<b>Computer actors:</b>	Sensors, wireless network, building control system.	
<b>Roles &amp; Responsibilities:</b>	Support of the building operator.	

<b>Scenario Description:</b>	Stakeholders can integrate the sensor network in built environments to better control the building operation and adapt it to user needs. This can lead to increased comfort and considerable energy savings.										
<b>Maturity of the result:</b>	<p style="text-align: center;">Research <span style="float: right;">Market</span></p> <table border="1" style="width: 100%; border-collapse: collapse;"> <tr> <td style="width: 25%;"></td> <td style="width: 25%;"></td> <td style="width: 25%;"></td> <td style="width: 25%;"></td> <td style="width: 12.5%;"></td> <td style="width: 12.5%;"></td> <td style="width: 12.5%;"></td> <td style="width: 12.5%;"></td> <td style="width: 12.5%;"></td> <td style="width: 12.5%;"></td> </tr> </table>										
<b>More information:</b>	[86]										

Table 6-8: Mobile User Interface overview [DRA]

<input type="checkbox"/> Product; <input type="checkbox"/> Service; <input checked="" type="checkbox"/> Process; <input type="checkbox"/> Other											
<b>Problem addressed:</b>	-										
<b>Target group:</b>	<table border="0" style="width: 100%;"> <tr> <td style="width: 50%; vertical-align: top;"> <input checked="" type="checkbox"/> Technology provider;  <input type="checkbox"/> Designer;  <input type="checkbox"/> Construction / developer;  <input type="checkbox"/> Manufacturer;  <input checked="" type="checkbox"/> System integrator;  <input checked="" type="checkbox"/> System supplier;         </td> <td style="width: 50%; vertical-align: top;"> <input type="checkbox"/> Site installation;  <input type="checkbox"/> Client / user;  <input checked="" type="checkbox"/> FM &amp; service provider;  <input type="checkbox"/> Research institute;  <input type="checkbox"/> University;  <input type="checkbox"/> SME.         </td> </tr> </table>	<input checked="" type="checkbox"/> Technology provider; <input type="checkbox"/> Designer; <input type="checkbox"/> Construction / developer; <input type="checkbox"/> Manufacturer; <input checked="" type="checkbox"/> System integrator; <input checked="" type="checkbox"/> System supplier;	<input type="checkbox"/> Site installation; <input type="checkbox"/> Client / user; <input checked="" type="checkbox"/> FM & service provider; <input type="checkbox"/> Research institute; <input type="checkbox"/> University; <input type="checkbox"/> SME.								
<input checked="" type="checkbox"/> Technology provider; <input type="checkbox"/> Designer; <input type="checkbox"/> Construction / developer; <input type="checkbox"/> Manufacturer; <input checked="" type="checkbox"/> System integrator; <input checked="" type="checkbox"/> System supplier;	<input type="checkbox"/> Site installation; <input type="checkbox"/> Client / user; <input checked="" type="checkbox"/> FM & service provider; <input type="checkbox"/> Research institute; <input type="checkbox"/> University; <input type="checkbox"/> SME.										
<b>Technology and business:</b>	Specification and implementation of multimodal interfaces to building data accessible via building service gateway. Design and development of the access to the building static and dynamic information in order for operation services personnel.										
<b>Objectives:</b>	Retrieving information and partly control the status of various controllable building components. Design and evaluation of user interfaces offering multimodal interaction characteristics.										
<b>Human actors:</b>	Operation Service Personal										
<b>Computer actors:</b>	Narrowband, Broadband services, voice/speech/video interactions										
<b>Roles &amp; Responsibilities:</b>	Specification and implementation of multimodal interfaces to building data. Definition and development of a generic object browser for usual mobile devices capable to interface with the object database and specializations for interacting with specific components. Definition and development of mechanisms for adaptation of the user presentation to the characteristics of the various terminal devices.										
<b>Scenario Description:</b>	-										
<b>Maturity of the result:</b>	<p style="text-align: center;">Research <span style="float: right;">Market</span></p> <table border="1" style="width: 100%; border-collapse: collapse;"> <tr> <td style="width: 25%;"></td> <td style="width: 25%;"></td> <td style="width: 25%;"></td> <td style="width: 25%;"></td> <td style="width: 12.5%;"></td> <td style="width: 12.5%;"></td> <td style="width: 12.5%;"></td> <td style="width: 12.5%;"></td> <td style="width: 12.5%;"></td> <td style="width: 12.5%;"></td> </tr> </table>										
<b>More information:</b>	[98]										

## 6.2 Discussions and pending issues – further work

Throughout the evolution of the project, many issues were considered and subjected to technical discussions. Some of them were discarded and others were suggested for further research outside the scope of this project, whilst others remain pending for schedule reasons.

### 6.2.1 Manufacture of GRC Sandwich panels with PCM packed in the core

After Differential Scanning Calorimetry (DSC) tests carried out by the IETCC-CSIC, it was found that the phase change (from solid to liquid state) of the PCMs was taking place between 16 and 20 °C. This range of temperatures is too low for the intended purposes of this project, since the material is going to be most of the time in liquid state. The ideal situation is to have a phase change within the comfort range, i.e. between 20 and 26 °C.

Therefore, the manufacturer has supplied new PCM boxes with a phase change temperature of 23 °C. New panels will be manufactured and installed in the Mock-up in replacement of the existing ones; this task will also serve to check the ease of assembly/disassembly of the prefabricated façade. The new panels will be measured and weighed to fill in *Table 6-9*, giving a summary of the different configurations, dimensions and weights. The new panels P-03 and P-09 must be fitted in time for carrying out the measurements (*see calendar in § 5.4.4*).

*Table 6-9: Structural configuration, height (H), width (W), thickness (T) and weight (M) of the Mock-up façade panels [DRA-SEIS]*

Panel	Configuration	H (mm)	W (mm)	T (mm)	M (kg)
P-01	GRC Stud-frame				
P-02	GRC Stud-frame				
P-03	GRC Sandwich Framex				
P-04	GRC Sandwich Framex				
P-05	GRC Sandwich				
P-06	Sheet-metal sandwich				
P-07	GRC Sandwich				
P-08	GRC Sandwich Framex				
P-09	GRC Sandwich Framex				
P-10	GRC Stud-frame				
P-11	GRC Stud-frame				
P-12	GRC Stud-frame				

### 6.2.2 Improved plasterboard prototype

- Additional research was conducted to produce a plasterboard prototype which shows improvements on:
  - o Thermal properties: enhanced by ~40% in weight of micro-capsules of PCM (in comparison to ~25% of commercial solution).
  - o Mechanical properties: enhanced by greater gypsum purity and polypropylene (PP) reinforcement (25 mm long, 7 denier<sup>126</sup> fibres).
- Different ways for manufacturing the prototype were considered:

<sup>126</sup> Unit of measurement of linear mass-density of textile fibre calculated as one gram per 9000 meters.

- o Handmade: pouring the raw materials (gypsum plaster, PCM micro-capsules, PP fibres, water, etc.) over a mould on a vibrating table to obtain the boards.
- o Applying the plaster manually by a craftsman over a conventional gypsum board would result in very rough finishing surfaces due to the high viscosity of the mixture, in spite of the different amounts dosages tested by ABIO trying to improve the fluency.
- o It was concluded that it would be necessary to find an industrial partner with the equipment and expertise for rolling the boards (this collaboration is out of the scope of this project).

### 6.2.3 Solar systems + PCMs

- The overall thermal performance could have been improved jointly by the contribution of the solar thermal collector (as a renewable energy source) and the under-floor heating enhanced with PCM<sup>127</sup>:
  - o The improvement could have been measured by monitoring the temperature of the rooms and the surface temperature on the floor with the UFH system on and off, so it could be calculated the response of the micro-capsules of paraffin and the amount of transferred heat.
  - o However, this issue was controversial and, following installation experts' advises<sup>128</sup>, PCMs were not incorporated to the floor.

### 6.2.4 Outdoor Weather Station (OWS)

- The weather station shown on *Fig. 6-1* was identified as a strong candidate for the OWS. It has the added benefit of a single hardware (not software) platform for the WSN. Additional sensors may be networked with OWS in order to create an outdoor WSN. TRT is currently testing this suite for integration into the WSN infrastructure (indoor and outdoor). Its use in the Mock-up was finally declined for budgetary reasons combined with the risk of theft giving its location, but its use may have several advantages according to the experts in the field<sup>129</sup>:
  - o Located on the module's roof, the OWS could be used to collect real-time data.
    - The unit would be connected to the WSN using Crossbow's technology, common to the rest of the WSN devices.
    - Data is periodically collected and stored; Crossbow's eKo system has a fixed sampling period.
    - Data is available to other users through the Web Service interface.
  - o Sensor data potentially available:
    - Outdoor temperature, with dew point and frost alerts.
    - Relative humidity (%). In conjunction with the temperature data, evapo-transpiration calculations may be performed.
    - Rainfall and precipitation data (mm per day, etc.).
    - Wind speed (m/s) and direction (°).
    - Barometric pressure (mbar).
    - Solar radiation (W/m<sup>2</sup>).

---

<sup>127</sup> F. Javier Neila (ABIO-UPM) dixit.

<sup>128</sup> José Luis Alfranca (Head of the Building Installations Service at Dragados).

<sup>129</sup> Hamid Asgari (TRT) said: "In order to collect outdoor data, a weather station is a better choice than to install individual sensors, since the OWS is weather proven".



*Fig. 6-1: eKo Outdoor Weather Station [Xbow]*

### 6.2.5 IFC model

As a future work, some I3CON partners suggested the development of an Industry Foundation Classes (IFC) model of the Mock-up using MagiCAD<sup>130</sup>. The author of this project contacted the developers of the program during summer 2010 and attended web seminars to learn how to use the different applications, which have the benefits inherent to every IFC models.

- IFC is an open, neutral and standardized specification for Building Information Modelling (BIM). It is an object-oriented file format with a data model developed by buildingSMART International<sup>131</sup> to facilitate interoperability in the building industry. It provides support for:
  - o Data exchange among software applications within the AEC/FM industry sector.
  - o Model-based description of spatial elements, building elements, MEP elements and other components that constitutes a building or facility.
  - o Shape representation of such components.
  - o Relationships of such components between each other and to the spatial and system structure.
  - o Attachment of properties, classifications, external library access, etc. to such components.

### 6.2.6 Conclusions of the measurements campaign and other analyses

As explained in § 5.3, the comparison of thermal performance of the different rooms' envelopes and the stabilization of the indoor temperature by means of passive systems is evaluated by establishing of a set of boundary conditions in the Mock-up and a measurements campaign intended to be carried out throughout different scenarios in summer (§ 5.4.1), autumn (§ 5.4.2) and winter time (§ 5.4.3). These measurements should be ideally taken in the dates suggested in § 5.4.4, which are yet to come.

The results of these measurements are very important to evaluate the thermal performance of the different envelope solutions and passive systems, so the author strongly recommends following up this issue.

---

<sup>130</sup> MagiCad, developed by Progman ([www.progman.fi](http://www.progman.fi)), is a 3D software for Building Services design, IFC 2x3 certified, that allows:

- Complete functionality for HVAC, piping, plumbing, sprinkler and electrical systems.
- Full 2D and 3D software with integrated calculations.
- Collision control and automatic section function.
- Full compatibility with AutoCAD based products.

<sup>131</sup> Formerly International Alliance for Interoperability (IAI); [www.iai-tech.org](http://www.iai-tech.org)



## 7 References and glossary

---

The datasheets were mostly downloaded from companies' websites. Since they may vary and/or disappear as a consequence of changes in the catalogues, discontinuity of products, etc., they have been gathered in the *Appendix III* of this Project for their consult.

The deliverables of I3CON Project are confidential documents, available on the I3CON Intranet only for the members of the consortium and the EU Commission Services. There exist published summaries accessible for the members of the Community of Interest.

The references are numbered in order of appearance throughout the text.

The acronyms employed throughout the text stand for the term in its original language, mostly English.

## 7.1 References

- [01] I3CON. "I3CON Project Homepage". [Online] [Cited: 21 January 2011] <http://www.i3con.org>
- [02] EIE. "Construction Special". The Magazine of the European Innovation Exchange. Issue 4, October 2010. [Online] [Cited: 21 January 2011] <http://www.eiex.eu>
- [03] I3CON. "Industrial, Integrated, Intelligent Construction". Wallis, I., Bilan, L. & Smith, M. (Eds.). Handbook 1, published by I3CON in collaboration with BSRIA ([www.bsria.co.uk](http://www.bsria.co.uk)), July 2009. ISBN 978-0-86022-683-3
- [04] I3CON. "Industrial, Integrated, Intelligent SUSTAINABLE Construction". Wallis, I., Bilan, L., Smith, M. & Kazi, A. S. (Eds.). Handbook 2, published by I3CON in collaboration with BSRIA ([www.bsria.co.uk](http://www.bsria.co.uk)), May 2010. ISBN 978-0-86022-698-7
- [05] I3CON. "Industrial, Integrated, Intelligent Construction. SOLUTIONS". Wallis, I., Bilan, L. & Smith, M. (Eds.). Handbook 3, published by I3CON in collaboration with BSRIA ([www.bsria.co.uk](http://www.bsria.co.uk)), September 2010. ISBN 978-0-86022-699-4
- [06] I3CON. "Step-by-step development of Facility Management Services. A practitioners' guide on the I3CON Service Engineering Approach (SEA)." Wohlfart, L.; Bilan, L. & Schimpf, S. (Eds). Published by I3CON in collaboration with University of Stuttgart, IAT ([www.iat.uni-stuttgart.de](http://www.iat.uni-stuttgart.de)), 2010.
- [07] Constructing Excellence in the Built Environment. "Demonstrations Programme". [Online][Cited: 21 January 2011] [http://www.constructingexcellence.org.uk/zones/sustainabilityzone/sust\\_con/demonstrations.jsp](http://www.constructingexcellence.org.uk/zones/sustainabilityzone/sust_con/demonstrations.jsp)
- [08] I3CON. Contract for Integrated Project "Industrialised, Integrated, Intelligent Construction". Annex 1: "Description of Work". European Commission, 2006.
- [09] I3CON D8.1. "Demonstration Scenarios and Plans".
- [10] I3CON D8.2. "Virtual Building Demonstrator".
- [11] I3CON D8.3. "Mock-up Demonstrator".
- [12] I3CON D8.4. "Real Building Demonstrator".
- [13] I3CON D4.1. "Integral planning of new components and production methods. Concepts for pathways for BSS installations and for new components"
- [14] I3CON D4.3. "New construction technologies for manufacturing of prefabricated integrated systems in factory environment"
- [15] I3CON D4.41. "Concepts for Smart Components and Materials supporting the BS architecture. Structural components and fittings based on fast build & services integration"
- [16] PRODOMER. "Mortero Prowool 200 Protección de estructuras metálicas". [Online] [Cited: 21 January 2011] <http://www.prodomer.com>. See also Appendix of Datasheets III.4
- [17] INTEMPER. "Filtrón". [Online] [Cited: 21 January 2011] <http://www.intemper.com>. See also Appendix of Datasheets III.4
- [18] INTEMPER. "Rhenofol CG". [Online] [Cited: 21 January 2011] <http://www.intemper.com>. See also Appendix of Datasheets III.4

- [19] INTEMPER. "Feltemper". [Online] [Cited: 21 January 2011] <http://www.intemper.com>. See also Appendix of Datasheets III.4
- [20] Documento de Idoneidad Técnica (DIT) Nº 367/R. "Sistema Drace para Cerramiento de Fachadas con Paneles de GRC". Instituto Eduardo Torroja de Ciencias de la Construcción, Madrid, 2007. See also Appendix of Datasheets III.2.3
- [21] HALFEN. "HFA channels". [Online] [Cited: 21 January 2011] [http://www.halfen.com/t/25\\_9825.html](http://www.halfen.com/t/25_9825.html)
- [22] PLACO (Saint-Gobain Gypsum). "Ficha de Producto Placas Estándar (STD)". [Online] [Cited: 21 January 2011] <http://www.placo.es>. See also Appendix of Datasheets III.2.4
- [23] DUPONT. "Energain". [Online] [Cited: 21 January 2011] [http://energain.co.uk/Energain/en\\_GB/index.html](http://energain.co.uk/Energain/en_GB/index.html)
- [24] Knaack, U.; Klein, T.; Bilow, M; and Auer, T. *Façades: Principles of Construction*. Basel: Birkhäuser, 2007. ISBN 978-3-7643-7962-9, p. 123.
- [25] SEVES. "Ladrillo de Vidrio". [Online] [Cited: 21 January 2011] <http://www.sevesglassblock.com>. See also Appendix of Datasheets III.2.1
- [26] KNAUF. "PCM SmartBoard". [Online] [Cited: 21 January 2011] <http://www.knauf.com>. See also Appendix of Datasheets III.2.4
- [27] BASF. "Micronal PCM Gypsum Wallboards". [Online] [Cited: 21 January 2011] <http://www.micronal.de>. See also Appendix of Datasheets III.2.4
- [28] FORMILINE. "Specification Report: High-pressure decorative laminates, Exterior Grade". [Online] [Cited: 21 January 2011] <http://www.formiline.com.br>. See also Appendix of Datasheets III.2.1
- [29] ATLANTIS. "52 mm FLO-CELL Drainage Cell". [Online] [Cited: 21 January 2011] <http://www.atlantiscorp.com.au/products/atlantis-52mm-flo-cell>
- [30] KNAUF. "Ultracoustic P". [Online] [Cited: 21 January 2011] <http://www.knaufinsulation.es>. See also Appendix of Datasheets III.4
- [31] UNE-EN 13501-1:2002 "Clasificación de los productos de la construcción y de los elementos constructivos en función de sus propiedades de reacción y de resistencia al fuego". AENOR, Madrid, 2002.
- [32] UNE-EN ISO 717-1:1997. "Acústica. Evaluación del aislamiento acústico en los edificios y de los elementos de construcción. Parte 1: Aislamiento a ruido aéreo". AENOR, Madrid, 1997.
- [33] UNE-EN 12667:2002. "Materiales de construcción. Determinación de la resistencia térmica por el método de la placa caliente guardada y el método del medidor de flujo de calor. Productos de alta y media resistencia térmica". AENOR, Madrid, 2002.
- [34] STACBOND. "Aluminium Composite Panel". [Online] [Cited: 21 January 2011] <http://www.stac.es>. See also Appendix of Datasheets III.2.1
- [35] ALCAN Composites. "Forex Color". [Online] [Cited: 21 January 2011] <http://www.display.3acomposites.com>. See also Appendix of Datasheets III.2.1
- [36] PERFINOR. "Panel Sándwich Lana de roca - Poliuretano - Panel Acústico (catálogo)". [Online] [Cited: 21 January 2011] <http://www.perfinor.com/productos.php?categoriaid=5>  
<http://www.perfinor.com/productos.php?categoriaid=5>. See also Appendix of Datasheets III.2.3

- [37] EURONIT. "Paintboard. Ficha de Información de Producto". [Online] [Cited: 21 January 2011] <http://www.euronit.es>. See also Appendix of Datasheets III.2.1
- [38] EURONIT. "Multi-Eterboard MD. Ficha de Información de Producto". [Online] [Cited: 21 January 2011] <http://www.euronit.es>. See also Appendix of Datasheets III.2.1
- [39] UNE 100030:2005. "Guía para la prevención y control de la proliferación y diseminación de legionela en instalaciones". AENOR, Madrid, 2005.
- [40] UPONOR. "D'MAND Hot Water Delivery System". [Online] [Cited: 21 January 2011] <http://www.uponorpro.com>. See also Appendix of Datasheets III.3.4
- [41] UPONOR. "Climatización Invisible Uponor Mini". [Online] [Cited: 21 January 2011] <http://www.uponor.com>. See also Appendix of Datasheets III.3.4
- [42] SGG. "Planitherm Ultra N & N-II. Low-E coated glass". [Online] [Cited: 21 January 2011] <http://www.saint-gobain-glass.com>. See also Appendix of Datasheets III.2.2
- [43] I3CON D4.42. "Solutions for controlling the internal environment through new functional materials & surfaces".
- [44] I3CON D3.52. "Concepts for Building System".
- [45] ROTEX. "Sanicube. El acumulador de agua caliente higiénica". [Online] [Cited: 21 January 2011] <http://www.rotex-heating.com>. See also Appendix of Datasheets III.3.3
- [46] ROTEX. "Solaris. Energía solar para ACS y Calefacción". See also Appendix of Datasheets; [www.rotex-heating.com](http://www.rotex-heating.com)
- [47] ROTEX. "Solaris. Solar Heating system. Operation and installation manual". [Online] [Cited: 21 January 2011] <http://www.rotex-heating.com>. See also Appendix of Datasheets III.3.3
- [48] ROTEX. "Solaris. Solar system on-roof installation. Installation Instructions". [Online] [Cited: 21 January 2011] <http://www.rotex-heating.com>. See also Appendix of Datasheets III.3.3
- [49] AERMEC. "ANL ANLH ANLC Technical Manual – Installation – Maintenance". [Online] [Cited: 21 January 2011] <http://www.aermec.com>. See also Appendix of Datasheets III.3.1
- [50] AERMEC. "FCL Cassette type fan coil Datasheet". [Online] [Cited: 21 January 2011] <http://www.aermec.com>. See also Appendix of Datasheets III.3.1
- [51] AERMEC. "FCL and FCLi Inverter Brochure". [Online] [Cited: 21 January 2011] <http://www.aermec.com>. See also Appendix of Datasheets III.3.1
- [52] ESBE. "Mixing Valve Series VRG130 Documentation". [Online] [Cited: 21 January 2011] <http://www.esbe.se>. See also Appendix of Datasheets III.3.2
- [53] ESBE. "Actuator Series ARA600 Prop Documentation". [Online] [Cited: 21 January 2011] <http://www.esbe.se>. See also Appendix of Datasheets III.3.2
- [54] I3CON D3.3. "Concepts for integrated building automation & control".
- [55] AERMEC. "ANL 040HA Manual Instalación". Pp. 102-128 [Scanned document] <http://www.aermec.com>. See also Appendix of Datasheets III.3.1
- [56] AERMEC. "Moducontrol. Manual Instalación". Pp. 107-132 [Scanned document] <http://www.aermec.com>. See also Appendix of Datasheets III.3.1
- [57] AERMEC. "ANL Wiring Diagram". [Scanned document] <http://www.aermec.com>. See also Appendix of Datasheets III.3.1

- [58] INDUSTRIE TECHNIK. "Liquid Flow Switches DBSF". [Online] [Cited: 21 January 2011] <http://www.industrietechnik.it>. See also Appendix of Datasheets III.1.3
- [59] LONIX. "Liquid Flow Switch LX-LFS-W". [Online] [Cited: 21 January 2011] <http://www.lonix.com>. See also Appendix of Datasheets III.1.3
- [60] WILO. "Stratos Eco-Z Series description, Duty chart, Equipment/function, Product list and data sheets". [Online] [Cited: 21 January 2011] <http://www.wilo.de>. See also Appendix of Datasheets III.3.2
- [61] WILO "Star-E Series description, Duty chart, Equipment/function, Product list and data sheets". [Online] [Cited: 21 January 2011] <http://www.wilo.de>. See also Appendix of Datasheets III.3.2
- [62] WILO "Star-RS Series description, Duty chart, Equipment/function, Product list and data sheets". [Online] [Cited: 21 January 2011] <http://www.wilo.de>. See also Appendix of Datasheets III.3.2
- [63] ESBE. "Actuator Series ARA600 Prop Installation". [Online] [Cited: 21 January 2011] <http://www.esbe.se>. See also Appendix of Datasheets III.3.2
- [64] ESBE. "Mixing Valve Series VRG130 Installation". [Online] [Cited: 21 January 2011] <http://www.esbe.se>. See also Appendix of Datasheets III.3.2
- [65] LONIX. "Counter Module 1000C". [Online] [Cited: 21 January 2011] <http://www.lonix.com>. See also Appendix of Datasheets III.1.2
- [66] LONIX. "Digimodule 5400P". [Online] [Cited: 21 January 2011] <http://www.lonix.com>. See also Appendix of Datasheets III.1.2
- [67] LONIX. "Multimodule 2242P". [Online] [Cited: 21 January 2011] <http://www.lonix.com>. See also Appendix of Datasheets III.1.2
- [68] RELECO. "Catálogo General MRC-QRC-IRC". [Online] [Cited: 21 January 2011] <http://www.releco.es>. See also Appendix of Datasheets III.1.1
- [69] LONIX. "Network Interface LNI". [Online] [Cited: 21 January 2011] <http://www.lonix.com>. See also Appendix of Datasheets III.1.2
- [70] AFOLUX. "Panel PC AFL-12A-V11". [Online] [Cited: 21 January 2011] <http://www.afolux.com>. See also Appendix of Datasheets III.1.2
- [71] HELKAMA. "Cable for instrumentation KLM-KLMA". [Online] [Cited: 21 January 2011] <http://www.helkamabica.fi>. See also Appendix of Datasheets III.1.1
- [72] ELECON. "Cable CYTEL FREE ZH RC4Z1 3x1". [Online] [Cited: 21 January 2011] <http://www.eleconsal.com>. See also Appendix of Datasheets III.1.1
- [73] LONIX. "Dimmer 4-channel LX-DIM-4". [Online] [Cited: 21 January 2011] <http://www.lonix.com>. See also Appendix of Datasheets III.1.2
- [74] PHILIPS. "HF-Regulator PL-T/C EII". [Online] [Cited: 21 January 2011] <http://www.philips.com>. See also Appendix of Datasheets III.1.1
- [75] ISTA. "Istameter Wasserzähler". [Online] [Cited: 21 January 2011] <http://www.ista.de>. See also Appendix of Datasheets III.1.3
- [76] ORBIS. "CONTAX-D 6331 SO. Manual de Uso". [Online] [Cited: 21 January 2011] <http://www.orbis.es>. See also Appendix of Datasheets III.1.3
- [77] KAMSTRUP. "Multical® 601". [Online] [Cited: 21 January 2011] <http://www.kamstrup.com>. See also Appendix of Datasheets III.1.3

- [78] KAMSTRUP. "LON Module for Multical 601". [Online] [Cited: 21 January 2011] <http://www.kamstrup.com>. See also Appendix of Datasheets III.1.3
- [79] KAMSTRUP. "Multical-601 & Ultraflow. Manual de Instalación y Uso". [Online] [Cited: 21 January 2011] <http://www.kamstrup.com>. See also Appendix of Datasheets III.1.3
- [80] LONIX. "Outdoor Temperature and Humidity Transducer LX-RHTE-O". [Online] [Cited: 21 January 2011] <http://www.lonix.com>. See also Appendix of Datasheets III.1.2
- [81] DELTAOHM. "LP PYRA 03 M Pyranometer". [Online] [Cited: 21 January 2011] <http://www.deltaohm.com>. See also Appendix of Datasheets III.5.1
- [82] DELTAOHM. "HD2007-08 Passive 4÷20 mA Humidity and Temperature Transmitters with configurable temperature working range". [Online] [Cited: 21 January 2011] <http://www.deltaohm.com>. See also Appendix of Datasheets III.5.1
- [83] PRODUAL. "Occupancy Sensor LA14". [Online] [Cited: 21 January 2011] <http://www.produal.com>. See also Appendix of Datasheets III.5.1
- [84] PRODUAL. "Temperature Sensor TEPK-PT1000". [Online] [Cited: 21 January 2011] <http://www.produal.com>. See also Appendix of Datasheets III.5.1
- [85] IEEE 802.15.4-2006. "IEEE Standard for Information technology –Telecommunications and information exchange between systems –Local and metropolitan area networks – Specific requirements. Part 15.4: Wireless Medium Access Control (MAC) and Physical Layer (PHY) Specifications for Low-Rate Wireless Personal Area Networks (WPANs)". Institute of Electrical and Electronics Engineers, New York, 2006.
- [86] I3CON D3.42. "Sensor network and middleware implementation and proof of concept".
- [87] FIGARO. "CDM4161 Pre-calibrated module for carbon dioxide. Product information". [Online] [Cited: 21 January 2011] <http://www.figaro.co.jp>. See also Appendix of Datasheets III.5.2
- [88] FIGARO. "TGS4161 for the detection of Carbon Dioxide. Product Information". [Online] [Cited: 21 January 2011] <http://www.figarosensor.com>. See also Appendix of Datasheets III.5.2
- [89] COMEDIA. "KC7783R PIR Module". [Online] [Cited: 21 January 2011] <http://www.comedia.co.hk>. See also Appendix of Datasheets III.5.2
- [90] CROSSBOW. "MICAz Wireless Measurement System". [Online] [Cited: 21 January 2011] <http://www.xbow.com>. See also Appendix of Datasheets III.5.2
- [91] CROSSBOW. "MOTE-KIT MICAz". [Online] [Cited: 21 January 2011] <http://www.xbow.com>. See also Appendix of Datasheets III.5.2
- [92] CROSSBOW. "MDA300CA Data Acquisition Board". [Online] [Cited: 21 January 2011] <http://www.xbow.com>. See also Appendix of Datasheets III.5.2
- [93] HAMMOND. "1591CFL Reader Drawing". [Online] [Cited: 21 January 2011] <http://www.hammondmfg.com/dwg2b.htm>. See also Appendix of Datasheets III.5.2
- [94] CROSSBOW. "MTS420-400 Environmental Sensor Board". [Online] [Cited: 21 January 2011] <http://www.xbow.com>. See also Appendix of Datasheets III.5.2
- [95] TAOS. "TSL2550 Ambient Light Sensor". [Online] [Cited: 21 January 2011] <http://www.taosinc.com>. See also Appendix of Datasheets III.5.2
- [96] SENSIRION. "SHT1x Humidity and Temperature Sensors". [Online] [Cited: 21 January 2011] <http://www.sensirion.com>. See also Appendix of Datasheets III.5.2



- [97] CROSSBOW. "MIB600CA Ethernet Interface Board". [Online] [Cited: 21 January 2011] <http://www.xbow.com>. See also Appendix of Datasheets III.5.2
- [98] I3CON D6.3. "Ambient user interfaces".
- [99] WAVETREND. "L-TG801 Tag". [Online] [Cited: 21 January 2011] <http://wavetrend.net>. See also Appendix of Datasheets III.1.4
- [100] 3M. "VHB-Tape". [Online] [Cited: 21 January 2011] [http://solutions.3m.com/wps/portal/3M/en\\_US/3M-Industrial/Adhesives/Product/Bonding-Tapes/VHB-Tape/](http://solutions.3m.com/wps/portal/3M/en_US/3M-Industrial/Adhesives/Product/Bonding-Tapes/VHB-Tape/)
- [101] ACI 544.1R-96. "State-of-the-Art Report on Fiber Reinforced Concrete." Chapter 3 "Glass Fiber Reinforced Concrete (GFRC)". American Concrete Institute, 2001.
- [102] Gilbert, Graham (Cement Composites Technology). "The use of admixtures in GRCA production". GRCA Technote 3 in CONCRETE, October 2008.
- [103] GRCA. "Specification for the manufacture, curing and testing of GRC products". The International Glassfibre Reinforced Concrete Association. Third edition, March 2010. ISBN 0 946691 78 9.
- [104] NETAFIM. "Unitechline AS 16mm". [Online] [Cited: 21 January 2011] <http://www.netafim.com>. See also Appendix of Datasheets III.2.5
- [105] NETAFIM. "Arrow dripper". [Online] [Cited: 21 January 2011] <http://www.netafim.com>. See also Appendix of Datasheets III.2.5
- [106] PEDROLLO. "Multi-stage centrifugal pumps 2-4CP". [Online] [Cited: 21 January 2011] <http://www.pedrollo.com>. See also Appendix of Datasheets III.2.5
- [107] AKO. "53112 Interruptor de nivel - Level switch". [Online] [Cited: 21 January 2011] <http://www.ako.com>. See also Appendix of Datasheets III.2.5
- [108] WEATHERMATIC. "Electroválvula Serie 12000". Ed. Regaber Jardinería. [Online] [Cited: 21 January 2011] <http://www.regaber.com>. See also Appendix of Datasheets III.2.5
- [109] WEATHERMATIC. "SmartLine Controller Manual". [Online] [Cited: 21 January 2011] <http://www.smartline.com>. See also Appendix of Datasheets III.2.5
- [110] MAPEI. "Primer G". [Online] [Cited: 21 January 2011] <http://www.mapei.com>. See also Appendix of Datasheets III.2.5 See also Appendix of Datasheets III.3.4
- [111] MAPEI. "Ultraplan Maxi". [Online] [Cited: 21 January 2011] <http://www.mapei.com>. See also Appendix of Datasheets III.2.5 See also Appendix of Datasheets III.3.4
- [112] MAPEI. "Keraquick Rapid Set Flexible Adhseive S1". [Online] [Cited: 21 January 2011] <http://www.mapei.com>. See also Appendix of Datasheets III.2.5 See also Appendix of Datasheets III.3.4
- [113] MAPEI. "Ultracolor Plus". [Online] [Cited: 21 January 2011] <http://www.mapei.com>. See also Appendix of Datasheets III.2.5 See also Appendix of Datasheets III.3.4

## 7.2 Glossary of terms and acronyms

<b>24/7</b>	24 hours per day, 7 days per week
<b>3D</b>	Three-dimensional
<b>A</b>	Ampere (a.k.a. Amp), unit of electricity current
<b>a.k.a.</b>	also known as
<b>A/C</b>	Air Conditioning
<b>ABIO</b>	Research group in Bioclimatic Architecture belonging to the ETSAM-UPM
<b>ABS</b>	Acrylonitrile Butadiene Styrene
<b>AC, also ac</b>	Alternating Current
<b>ACS</b>	Activities, Construction & Services (from the Spanish <i>Actividades, Construcciones y Servicios</i> ) - Dragados' parent company
<b>ADSL</b>	Asymmetric Digital Subscriber Line
<b>AEC</b>	Architecture, Engineering and Construction
<b>AHU</b>	Air Handling Unit
<b>AI</b>	Analogical Input
<b>am</b>	Before noon (from the Latin <i>Ante Meridiem</i> )
<b>AO</b>	Analogical Output
<b>ASR</b>	Automatic Speech Recognition
<b>AT</b>	Ambient Temperature
<b>BACS</b>	Building Automation & Control System
<b>BIM</b>	Building Information Modelling
<b>BIOS</b>	Basic Input/Output System
<b>BMS</b>	Building Management System
<b>BoM</b>	Bill of Materials
<b>BOS</b>	Building Operating System
<b>BTU</b>	British Thermal Unit
<b>C&amp;P</b>	CO <sub>2</sub> and Presence sensors

---

<b>CAD</b>	Computer Aided Design
<b>CAM</b>	Computer-Aided Manufacturing
<b>CF</b>	Chip Flash
<b>CO<sub>2</sub></b>	Carbon Dioxide
<b>COBA</b>	Connected Open Building Automation
<b>Col</b>	Community of Interest
<b>CPU</b>	Central Processing Unit
<b>CSIC</b>	High Council for Scientific Research of Spain (from the Spanish <i>Consejo Superior de Investigaciones Científicas</i> )
<b>CTE</b>	Technical Standards for Building (from the Spanish <i>Código Técnico de la Edificación</i> )
<b>D</b>	Depth
<b>D+P</b>	Draaijer + Partners - company, 3CON Partner
<b>dB</b>	Decibel, unit of noise level
<b>DB-HE</b>	Basic Directives for Energy Savings in buildings (from the Spanish <i>Documento Básico de Ahorro de Energía</i> )
<b>DC, also dc</b>	Direct Current
<b>DCS</b>	Distributed Control System
<b>DDC</b>	Direct Digital Control
<b>DFMLA</b>	Design For Manufacturing, Logistics and Assembly
<b>DHW</b>	Domestic Hot Water
<b>DI</b>	Digital Input
<b>DIT</b>	Technical Suitability Report (from the Spanish <i>Documento de Idoneidad Técnica</i> )
<b>DO</b>	Digital Output
<b>DoW</b>	Description of Work
<b>DRA</b>	Dragados - company, I3CON Partner
<b>DSC</b>	Differential Scanning Calorimetry

---

<b>EC</b>	Electro-Chromic European Commission
<b>ECGU</b>	Electro-Chromic Glazing Unit
<b>EMVS</b>	Municipal Housing & Land Company of Madrid (from the Spanish <i>Empresa Municipal de la Vivienda y Suelo de Madrid</i> ) - company, I3CON Partner
<b>EN</b>	European Norm
<b>EPS</b>	Expanded Poly-Styrene
<b>ETSAM</b>	Technical School of Architecture of Madrid (from the Spanish <i>Escuela Técnica Superior de Arquitectura de Madrid</i> )
<b>EU</b>	European Union
<b>EUD</b>	End-User Declaration
<b>FCU</b>	Fan-Coil Unit
<b>FLIR</b>	Forward Looking Infrared
<b>FM</b>	Facilities Management
<b>FP</b>	EU Sixth Framework Programme for Research and Technological Development (6 <sup>th</sup> : 2002-2006; 7 <sup>th</sup> : 2007-2013)
<b>GPRS</b>	General Packet Radio Service
<b>GRC</b>	Glass-fibre Reinforced Concrete
<b>H&amp;S</b>	Health & Safety
<b>HDPE</b>	High-Density Poly-Ethylene
<b>HLT</b>	Humidity, Light and Temperature sensors
<b>HSS</b>	Hollow Structural Section
<b>HTTP</b>	Hyper-Text Transfer Protocol
<b>HV</b>	High Voltage
<b>HVAC</b>	Heating, Ventilation and Air Conditioning
<b>HW</b>	Hardware
<b>I/O</b>	Input/Output
<b>I+D</b>	Research & Development (from the Spanish <i>Investigación + Desarrollo</i> )
<b>I3CON</b>	Industrialized, Integrated, Intelligent Construction

---

<b>IAO</b>	Institute for Industrial Engineering and Organization (from the German <i>Institut für Arbeitswirtschaft und Organisation</i> ) - I3CON Partner
<b>IBS</b>	Intelligent Building System
<b>ICOM</b>	Intracom - company, I3CON partner
<b>ICT</b>	Information and Communication Technology
<b>ID</b>	Identification
<b>IEEE</b>	Institute of Electrical and Electronics Engineers
<b>IETCC</b>	Institute for Construction Science "Eduardo Torroja" (from the Spanish <i>Instituto Eduardo Torroja de Ciencias de la Construcción</i> )
<b>IFC</b>	Industry Foundation Classes
<b>iMat</b>	Construction Technology Centre of Catalonia
<b>INT</b>	Intemper - company
<b>IP</b>	Ingress Protection Internet Protocol
<b>ISO</b>	International Organization for Standardization
<b>JRE</b>	Java Runtime Engine
<b>JSP</b>	Java Server Pages
<b>k</b>	Kilo (prefix) = $10^3$
<b>L</b>	Length
<b>LAN</b>	Local Area Network
<b>LCD</b>	Liquid Crystal Display
<b>LEED</b>	Leadership in Energy and Environmental Design
<b>LON</b>	Lonix - company, I3CON Partner LonWorks - communications protocol
<b>LOU</b>	Loughborough University - I3CON Partner
<b>LV</b>	Low Voltage
<b>m</b>	meter mili (prefix) = $10^{-3}$
<b>M&amp;C</b>	Monitoring & Control

---

<b>MEP</b>	Mechanical, Electrical and Plumbing
<b>MPT</b>	Mobile Productivity Tool
<b>MSTS</b>	Multi-Services Trunking System
<b>NC</b>	Normally Closed
<b>NMP</b>	Nanotechnology and nano-sciences, knowledge-based multifunctional materials and new production processes and devices
<b>NO</b>	Normally Open
<b>NOx</b>	Nitrogen oxides: NO (Nitric oxide) and NO <sub>2</sub> (Nitrogen dioxide)
<b>NTUA</b>	National Technical University of Athens
<b>O&amp;M</b>	Operation and Maintenance
<b>OS</b>	Operative System
<b>OSM</b>	Off-Site Manufacturing
<b>OWS</b>	Outdoor Weather Station
<b>PC</b>	Personal Computer
<b>PCM(s)</b>	Phase Change Material(s)
<b>PDA</b>	Personal Digital Assistant
<b>PDF</b>	Portable Document Format
<b>PE</b>	Poly-Ethylene
<b>PEX</b>	Cross-linked Poly-Ethylene
<b>PFC</b>	Final Project (from the Spanish <i>Proyecto Fin de Carrera</i> )
<b>PIR</b>	Passive Infra-Red
<b>PLC</b>	Power Line Communication Programmable Logic Controller
<b>pm</b>	After noon (from the Latin <i>Post Meridiem</i> )
<b>PMMA</b>	Poly-Methyl Methacrylate
<b>PoE</b>	Power over Ethernet
<b>PP</b>	Poly-Propylene
<b>PPP</b>	Public-Private Partnership



---

<b>PUR</b>	Polyurethane
<b>PV</b>	Photo-Voltaic
<b>PVC</b>	Poly-Vinyl Chloride
<b>PWM</b>	Pulse-Width Modulation
<b>PYME</b>	Small- and Medium-sized Enterprise (from the Spanish <i>Pequeña y Mediana Empresa</i> )
<b>R&amp;D</b>	Research and Development
<b>RAM</b>	Random Access Memory
<b>RBE</b>	Rule Based Engine
<b>REST</b>	Representational State Transfer
<b>RF</b>	Radio-Frequency
<b>RFID</b>	Radio-Frequency Identification
<b>RSL</b>	Raúl Sánchez Labrador - Author of this Project
<b>RH</b>	Relative Humidity
<b>RTD</b>	Research and Technological Development
<b>S.A.</b>	Corporation (from the Spanish <i>Sociedad Anónima</i> )
<b>SD</b>	Secure Digital
<b>SEA</b>	Service Engineering Approach
<b>SEIS</b>	Sustainable Integral Building Solutions (from the Spanish <i>Soluciones de Edificación Integrales y Sostenibles</i> ) - Dragados' child company
<b>SGR</b>	Saint-Gobain Recherche - company, I3CON Partner
<b>SI</b>	International System of Units (from the French <i>le Système International d'unités</i> )
<b>SMART</b>	Specific, Measurable, Achievable, Realistic and Tangible
<b>SME</b>	Small- and Medium-sized Enterprises
<b>SSL</b>	Secure Socket Layer (superseded by TLS -Transport Layer Security)
<b>ST</b>	Surface Temperature
<b>SW</b>	Software

---

<b>t</b>	thickness time
<b>T</b>	Temperature
<b>TCP/IP</b>	Transmission Control Protocol / Internet Protocol
<b>TDH</b>	Total Dynamic Head
<b>TE</b>	Technical Earth
<b>TRT</b>	Thales Research and Technologies - company, I3CON Partner
<b>TTS</b>	Text-To-Speech
<b>TV</b>	Television
<b>TX.Y</b>	Task X.Y
<b>UC3M</b>	University Carlos III of Madrid (from the Spanish <i>Universidad Carlos III de Madrid</i> ) - I3CON Partner
<b>UFH</b>	Under-Floor Heating
<b>UI</b>	User Interface
<b>UK</b>	United Kingdom
<b>UMTS</b>	Universal Mobile Telecommunications System
<b>UPM</b>	Polytechnic University of Madrid (from the Spanish <i>Universidad Politécnica de Madrid</i> )
<b>UPO</b>	Uponor - company, I3CON Partner
<b>UPS</b>	Uninterruptible Power Supply
<b>US</b>	United States
<b>USB</b>	Universal Serial Bus
<b>U-value</b>	Overall Heat Transfer Coefficient ( $W/m^2 \cdot K$ )
<b>V</b>	Volt, unit of electromotive force (a.k.a. Voltage)
<b>VA</b>	Volt-Ampere, unit of energy
<b>VMA</b>	Viscosity Modifying Admixtures
<b>VTT</b>	Technical Research Centre of Finland (from the Finish <i>Valtion Teknillinen Tutkimuskeskus</i> ) - I3CON Partner
<b>W</b>	Width



<b>WC</b>	Water Closet
<b>Wh</b>	Watt-hour, unit of energy
<b>WLCA</b>	Whole Life Cycle Assessment
<b>WP(s)</b>	Work Package(s)
<b>WSN</b>	Wireless Sensor Network
<b>XBOW</b>	Crossbow - company
<b>XPS</b>	Extruded Polystyrene
<b>μ</b>	micro (prefix) = $10^{-6}$
<b>Ω</b>	Ohm, unit of electrical resistance



# Appendixes

---

## I. Appendix I: Mock-up Drawings

---

Architectural drawings were done by SEIS' architects and reviewed by Dragados' Service of R&D Projects in Buildings and processes and the author of this project<sup>132</sup>.

Engineering drawings were done by external consulting engineers and reviewed by Dragados' Service of Building Installations<sup>133</sup>.

All drawings were approved by I3CON Project Coordinator<sup>134</sup>, and were drafted both in Spanish and English.

Models were mostly generated with AutoCAD® and rendered with 3DMAX®, both programs developed by Autodesk™.

### I.1 Appendix I.1: Architectural Drawings

**AR-01.** *Ubicación* – Location

**AR-02.** *Planta acotada del módulo. Designación de recintos y paneles de fachada* – Layout and dimensions. Rooms and façade panels' designation.

**AR-03.** *Estructura: Cimentaciones* – Structure: Foundations

**AR-04.** *Estructura: Sección longitudinal* – Structure: Longitudinal cross section

**AR-05.** *Alzados* – Elevations

**AR-06.** *Sección Longitudinal A* – Longitudinal Section A

**AR-07.** *Sección Longitudinal B* – Longitudinal Section B

**AR-08.** *Secciones Transversales C y D* – Cross Sections C & D

**AR-09.** *Paneles de fachada: Detalles en planta* – Façade Panels: Top view details

**AR-10.** *Paneles de fachada P-02 y P-10: Stud-frame trasdosado con PVL+PCM* – Façade Panels P-02 & P-10: Stud-frame with PCM-enhanced plasterboard sheathing

**AR-11.** *Paneles de Fachada P-03 y P-09: Sandwich Framex con cajas de PCM* – Façade Panels P-03 & P-09: Sandwich Framex with PCM boxes

**AR-12.** *Paneles de Fachada P-04 y P-08: Sandwich Framex con módulos vegetados* – Façade Panels P-04 & P-08: Sandwich Framex with vegetated modules

**AR-13.** *Paneles de Fachada P-06 y P-12: Stud-frame con acabados externos especiales* – Façade Panels P-06 & P-12: Stud-frame with special external finishing

---

<sup>132</sup> Raúl Sánchez Labrador (UC3M).

<sup>133</sup> José Luis Alfranca González (DRA).

<sup>134</sup> Miguel J. Segarra Martínez (DRA).

- AR-14.** *Paneles Vegetados: Fachada sur* – Vegetated Panels: South elevation
- AR-15.** *Paneles Vegetados: Fachada norte* – Vegetated Panels: North elevation
- AR-16.** *Paneles Vegetados: Sistema de riego y sensores* – Vegetated Panels: watering system and sensors
- AR-17.** *Ventanas: Carpinterías y detalles de cableado vidrio electro-crómico* – Windows: Metalwork and ECGU cabling details
- AR-18.** *Planta de cubierta. Detalles de Impermeabilización* – Roof Layout. Waterproofing details

## I.2 Appendix I.2: Engineering Drawings

Note: Technical explanation of the following drawings is gathered in the Installations Report. The installations project was carried by a consulting engineering practice and it is considered neither research work nor part of this PFC.

### I.2.1 Structure

- ES-01.** *Forjado de suelo* – Floor slab
- ES-02.** *Forjado de cubierta* – Roof slab

### I.2.2 Plumbing

- FO-01.** *Fontanería: Esquema de principio* – Plumbing: Functioning Diagram
- FO-02.** *Fontanería: Planta* – Plumbing: Layout
- FO-03.** *Fontanería y Sistemas solares: Planta baja* – Plumbing and Solar systems: Ground floor
- FO-04.** *Fontanería y Sistemas solares: Planta de cubiertas* – Plumbing and Solar systems: Roof
- FO-05.** *Fontanería y Sistemas solares: Sección transversal* – Plumbing and Solar systems: Cross section

### I.2.3 Drainage

- SA-01.** *Saneamiento: Planta* – Drainage: Layout
- SA-02.** *Saneamiento: Sección transversal* – Drainage: Cross section

### I.2.4 HVAC

- CL-01.** *Climatización: Esquema de principio* – HVAC: Functioning Diagram
- CL-02.** *Climatización: unidades difusoras* – HVAC: Fan coil units
- CL-03.** *Climatización: calefacción por suelo radiante* – HVAC : Under-floor heating



**CL-04.** *Climatización: Equipos en cubierta* – HVAC: Roof equipment

**CL-05.** *Climatización: Sección del entramado de tuberías* – HVAC : Piping deployment cross section

## **I.2.5 Electricity and Control System**

**EL-01.** *Electricidad* – Electricity

**EL-02.** *Despliegue de los sensores* – Sensors deployment

**EL-03.** *Panel fotovoltaico* – Photovoltaic panel

**EL-04.** *Sistema de Control* – Control system

Note: Additional drawings about the wiring of the control system were necessary but are not to be disclosed. The same can be said of the “as built” drawings.

## II. Appendix II: Schedule

---

All the activities regarding the Mock-up construction, assembly and operation were carefully scheduled between Dragados' R&D Directorate and SEIS' Factory Director in accordance to all I3CON partners. The planning, including dates and critical paths, is detailed in a Microsoft Project Plan (MPP). Several versions were generated to adjust the planning to the unforeseen overruns.

- The planned activities comprised:
  - o Mock-up structure construction.
  - o Components manufacturing and shipment to SEIS' factory.
  - o Partners' visits to supervise their components assembly and/or to install their systems.
  - o Subcontracted activities (piping, ductwork, wiring, etc.).
  - o Functioning tests.
  - o Documentation activities and dissemination material (photographs, video, posters, explanatory signage, leaflets, project and corporate image, etc.).
  - o Periodical data collection and performance measurements.
  - o Operation planning.

## III. Appendix III: Datasheets

---

### III.1 BOS

#### III.1.1 Cable & Light

- ELECON Cable CYTEL FREE ZH RC4Z1 3x1
- HELKAMA Cable for instrumentation KLM-KLMA
- JUNG 1-gang push-button
- PHILIPS HF-Regulator PL-TC EII
- RELECO Catálogo General MRC-QRC-IRC
- TOXFREE ZH RC4Z1-K Cable

#### III.1.2 LON

- AFOLUX Panel PC AFL-12A-V11
- LONIX Counter Module 1000C
- LONIX Digimodule 5400P
- LONIX Dimmer 4-channel LX-DIM-4
- LONIX Multimodule 2242P
- LONIX Network Interface LNI
- LONIX Outdoor Temperature and Humidity Transducer LX-RHTE-O
- LONIX Room Temperature Transducer with Potentiometer and Display LX-TE-R-AP-P-LCD

#### III.1.3 Meters

- INDUSTRIETECHNIK Liquid Flow Switches DBSF
- ISTA Istameter Hardware Fact Sheet
- ISTA Istameter Wasserzähler
- KAMSTRUP LON Module for Multical-601
- KAMSTRUP Multical-601 & Ultraflow. Manual de Instalación y Uso
- KAMSTRUP Multical-601
- KAMSTRUP Ultraflow type 65-S65-R Installation
- LONIX Liquid Flow Switch LX-LFS-W
- ORBIS Contax-D 6331 SO

#### III.1.4 Tags

- WAVETREND L-TG801 TAG

## III.2 FAÇADES

### III.2.1 Claddings

- ALCAN Composites Forex Color
- EURONIT Multi-Eterboard MD. Ficha de Información de Producto
- EURONIT Paintboard. Ficha de Información de Producto
- FORMILINE Exterior Grade (wood)
- SEVES Ladrillo de Vidrio
- STACBOND Aluminium Composite Panel
- STACBOND Technical Drawings

### III.2.2 ECGU

- SGG Planitherm Ultra N & N-II. Low-E coated glass

### III.2.3 Frames & Panels

- CONDESA FABRIL Certificado de calidad de los tubos bastidor
- DIT 367-R Sistema DRACE para cerramiento de fachadas con paneles prefabricados de GRC
- PERFINOR Panel de Fachada Poliuretano (plano)
- PERFINOR Panel Sandwich Lana de roca - Poliuretano - Panel Acústico (catálogo)

### III.2.4 Plasterboards

- BASF Micronal PCM Gypsum Wallboards
- KNAUF PCM Smartboard
- PLACO Placa Yeso Laminado Estándar

### III.2.5 Watering System

- AKO 53112 Interruptor de nivel - Level switch
- NETAFIM Arrow dripper
- NETAFIM Unitechline AS 16mm
- PEDROLLO Multi-stage centrifugal pumps 2-4CP
- WEATHERMATIC Electroválvula Serie 12000
- WEATHERMATIC SmartLine Controller Manual

## III.3 HVAC

### III.3.1 Air Conditioning

- AERMEC ANL 040HA Manual Instalación 102-128
- AERMEC ANL ANLH ANLC Technical Manual - Installation – Maintenance
- AERMEC ANL Wiring Diagram
- AERMEC FCL and FCLI Inverter Brochure

- AERMEC FCL Cassette type fan coil Datasheet
- AERMEC Moducontrol 107-119
- AERMEC Moducontrol 120-132

### III.3.2 Pumps & Valves

- ESBE Actuator Series ARA600 Prop Documentation
- ESBE Actuator Series ARA600 Prop Installation
- ESBE Mixing Valve Series VRG130 Documentation
- ESBE Mixing Valve Series VRG130 Installation
- ROCA SB Pump for hot water systems
- WILO Star-E
- WILO Star-RS
- WILO Stratos-ECO-Z

### III.3.3 Solar Systems

- ROTEX Sanicube. El acumulador de agua caliente higiénica. Brochure
- ROTEX Solaris. Energía solar para ACS y Calefacción. Brochure
- ROTEX Solaris. Solar Heating system. Operation and installation manual
- ROTEX Solaris. Solar system on-roof installation. Installation Instructions

### III.3.4 Underfloor Heating

- MAPEI Keraquick Rapid Set Flexible Adhesive S1
- MAPEI Primer G
- MAPEI Ultracolor Plus
- MAPEI Ultraplan Maxi
- UPONOR DMAND Cutsheet
- UPONOR Dynamic Energy Management1
- UPONOR Dynamic Energy Management2
- UPONOR Radio Control System

## III.4 INSULATION

- APPLUS Informe de estabilidad al fuego Prowool 200
- INTEMPER Feltemper
- INTEMPER Losa Filtrón
- INTEMPER Rhenofol CG
- KNAUF Ultracoustic P
- PRODOMER Mortero Prowool 200 Protección de estructuras metálicas

## III.5 SENSORS

### III.5.1 Wired

- DELTAOHM HD2007-08 Passive 4÷20 mA Humidity and Temperature Transmitters with configurable temperature working range
- DELTAOHM LP PYRA 03 M Pyranometer
- PRODUAL Occupancy Sensor LA14
- PRODUAL Temperature Sensor TEPK-PT1000WSN

### III.5.2 Wireless

- CROSSBOW MDA300CA Data Acquisition Board
- CROSSBOW MIB600CA Ethernet Interface Board
- CROSSBOW MICAz Wireless Measurement System
- CROSSBOW MOTE-KIT MICAz
- CROSSBOW MTS420-400 Environmental Sensor Board
- CROSSBOW Product Reference Guide
- HAMMOND 1591CFL Reader Drawing
- C&P
  - COMEDIA KC7783R PIR Module
  - FIGARO CDM4161 Pre-calibrated module for carbon dioxide. Product information
  - FIGARO TGS4161 for the detection of Carbon Dioxide. Product Information
- HLT
  - SENSIRION SHT1x Humidity and Temperature Sensors
  - TAOS TSL2550 Ambient Light Sensor



## IV. Appendix IV: Bill of Materials

---

This appendix is a spreadsheet gathered in a Microsoft Excel Sheet (XLS) file.

- It was used to list all the items and their corresponding IDs, including every relevant piece of information such as:
  - o Manufacturer.
  - o Characteristics of the specified models.
  - o Expected and checked quantities.
  - o Price and the subtotal to be added to the budget.
  - o Contact information of the supplier.
  - o Partner involved in the design.
  - o Links to relevant websites and/or the fact sheets.
  - o Notes regarding installation.
  - o Etc.



## V. Appendix V: Cabling

---

This appendix is a Portable Document Format (PDF) file created by the I3CON Partner Lonix (LON) to facilitate the wiring of the different metering devices, sensors and actuators to and from the DDC panel where all the LON modules are fitted.