



University for the Common Good

A single chip solution for pulse transmit time measurement

Knezevic, Sasa; Stojanovic, Radovan; Asanin, Bogdan; Karadaglic, Dejan

Published in:

2013 IEEE 13th International Conference on Bioinformatics and Bioengineering (BIBE)

DOI:

[10.1109/BIBE.2013.6701625](https://doi.org/10.1109/BIBE.2013.6701625)

Publication date:

2013

Document Version

Peer reviewed version

[Link to publication in ResearchOnline](#)

Citation for published version (Harvard):

Knezevic, S, Stojanovic, R, Asanin, B & Karadaglic, D 2013, A single chip solution for pulse transmit time measurement. in *2013 IEEE 13th International Conference on Bioinformatics and Bioengineering (BIBE)*., 14026341, IEEE, pp. 1. <https://doi.org/10.1109/BIBE.2013.6701625>

General rights

Copyright and moral rights for the publications made accessible in the public portal are retained by the authors and/or other copyright owners and it is a condition of accessing publications that users recognise and abide by the legal requirements associated with these rights.

Take down policy

If you believe that this document breaches copyright please view our takedown policy at <https://edshare.gcu.ac.uk/id/eprint/5179> for details of how to contact us.

A Single Chip Solution for Pulse Transmit Time Measurement

Saša Knežević, Radovan Stojanović, Bogdan Ašanin and Dejan Karadaglić

Abstract—This paper proposes a methodology for Pulse Transmit Time measurement for purposes of cuff-less monitoring of Blood Pressure. The ECG and PPG signals are simultaneously acquired and Pulse Transmit Time is determined as a time between R peak in ECG and maximal slope in PPG. To distinguish characteristic points Discrete Wavelet Transform, Derivative Filtering, Modulus Maxima and additional functions are employed and translated in VHDL code and then embedded in a single chip from FPGA technology. The system works on-line, achieving accuracy of 97.53% and 97.09% for R peak and slope detection respectively. The emphasis is given to the description of signal processing approach, system architecture and working principles of fundamental components. Also, the preliminary testing results are presented.

I. INTRODUCTION

Supplemented by other physiological parameters, the Blood Pressure (BP) is considered as an invaluable diagnostic parameter to access the condition of certain illnesses, especially cardiovascular, which are a leading cause of death worldwide [1]. Continuous monitoring of BP is highly recommended in order to respond timely. The measurement techniques are divided into two categories: direct and indirect. The direct technique is in fact invasive, used when a high level of accuracy, dynamic response and continuous monitoring are required. A catheter with pressure transducer is directly inserted into blood vessel. The indirect techniques, almost existing more than one century, rely on concept of inflatable cuff to the arm which applied auscultatory or oscillometry principle. Presence of the cuff reduces the efficiency and flexibility of the meters in terms of power consumption, measurement frequency, patient mobility, ease of use, etc.

The Pulse Transit Time (PTT) method is a cuff-less alternative to the classical indirect methods [2]. The PTT is the time which BP pulse takes to travel from one arterial site to another. It is inverse proportional to the BP value. Typically, the PTT is initiated by the R-wave of the ECG signal and the arrival, at finger or ear, is, usually, detected

from photoplethysmograph (PPG) signal, in a point of its maximal slope MS, Fig. 1.

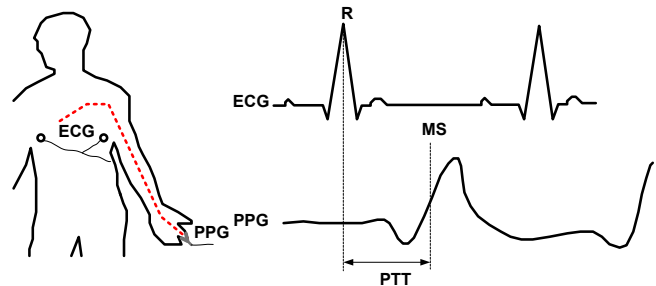

Fig. 1. The principle of PTT measurement.

The suspension of cuff and beat-to-beat tracking are the main advantages that recommend this method for application in wearable and telemedical devices, which are autonomous, miniature, low-cost, ultra-low-power devices and very often in form of a single chip. In practice, it is not a trivial task to embed all necessary processing operations in a single chip of limited arithmetic, memory and power consumption performances. An additional request is on-line operation.

This paper presents a trial in this direction. It proposes a methodology to implement an on-line system for PTT measurement in a single chip from FPGA technology. First, the characteristic points in ECG and PPG signals are distinguished using optimized Discrete Wavelet Transform (DWT), Derivative Filtering, Modulus Maxima and additional functions. Second, all signal processing functions are developed in VHDL code and embedded into functional modules which are later integrated in FPGA chip. Third, the approach is verified using real signals and obtained results are presented and discussed.

II. METHODOLOGY

Signal processing and operation flowchart consists of two parallel tracks: *QRS detection* and *PPG slope detection*, Fig. 2. Initially, the both signals are passed through the DWT decomposition module which consists of low-pass (L) and high-pass (H) filters according to the Mallat's scheme [3]. $A_i(n)$ and $D_i(n)$, known as approximation and detail coefficients, are the outputs from these filters for i^{th} decomposition level. In this research the integer modification of Haar wavelet transform, here marked as *Haar DWT*, is used for wavelet decomposition [4].

In case of ECG, Haar DWT, as any other wavelet transform, is capable to distinguish the QRS complexes within ECG signal. The $D_i(n)$ coefficients across the scales show that the R peak of the QRS complex corresponds to the

Manuscript received August 21, 2013. This work was supported by National project of Ministry of Science of Montenegro, MESI, and EU TEMPUS project BioEMIS. The authors are thankful for support.

S. K. is with the Faculty of Electrical Engineering, University of Montenegro, Podgorica, Montenegro (e-mail: sasaknezevic@live.com).

R. S. and N.L. are with the Faculty of Electrical Engineering, University of Montenegro, Podgorica, Montenegro (e-mail: stox@ac.me).

B.A. is with the Faculty of Medicine, University of Montenegro, Podgorica, Montenegro (e-mail: basanin@ac.me).

D. K. is with the School of Engineering and Built Environment, Glasgow Caledonian University, Glasgow, United Kingdom (e-mail: Dejan.Karadagic@gcu.ac.uk).

zero crossing (ZC) between two local modulus maxima. In case of PPG, the approximation coefficients $A_i(n)$ are fed to the first order derivative filter producing signals $Dif_i(n)$. Maximal slope in original PPG signal, MS, corresponds to the local maxima in $Dif_i(n)$. To improve accuracy of detection the coefficients $D2f_i(n)$ and $D3f_i(n)$ are also examined on local maxima. When R or MS are detected the adequate trigger signals are generated and forwarded to the PTT calculator module, which is in fact a timer for PTT measurement.

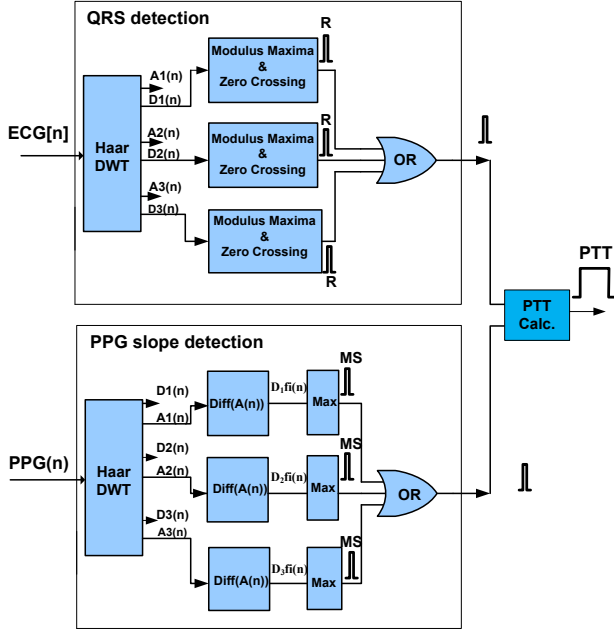

Fig. 2. PTT Signal processing approach.

Fig. 3 illustrates the decomposition of real discrete signal $ECG(n)$ up to the 4th decomposition level of details, $D_1(n)$, $D_2(n)$, $D_3(n)$ and $D_4(n)$. Simultaneously the signal $PPG(n)$ is decomposed till 4th level of approximations, $A_1(n)$, $A_2(n)$, $A_3(n)$ and $A_4(n)$ and then fed to the derivative filter, producing signals $D1f_i(n)$, $D2f_i(n)$, $D3f_i(n)$ and $D4f_i(n)$. It is seen how R peak corresponds to the zero crossing of $D_i(n)$ and MS to local maxima of $Dif_i(n)$.

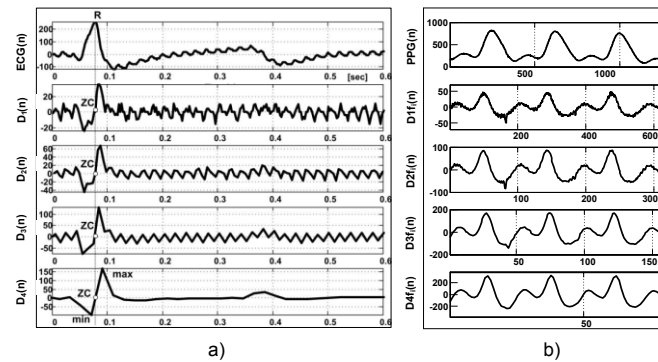

Fig. 3. (a) ECG signal and detail coefficients from 4 levels of decomposition (b) PPG signal with first derivations of 4 levels of approximations.

III. FPGA IMPLEMENTATION

A. System Architecture

FPGA implementation of PTT meter follows the functional diagram in Fig. 4. It consists of several modules and runs by 50MHz clock. Analog signals $ECG(t)$ and $PPG(t)$ are digitalized by 12bit A/D convertor TLC2543 (TI) under sampling frequency of $f_s=800Hz$. A/D converter is driven by A/D controller module producing the digital samples $ECG[n][11..0]$ and $PPG[n][11..0]$. These samples are then fed to the *ECG processing core* and *PPG processing core* respectively. *ECG processing core* produces *QRS_pulse* which indicates detected R wave while *PPG processing core* detects maximal slope MS in PPG and generates *PPG_slope_pulse*. *QRS_pulse* and *PPG_slope_pulse* are inputs to the *PTT_calculator* module which calculate $PTTI[10..0]$, an integer equivalent of *PTT*. $PTTI[10..0]$ is sent out by UART controller.

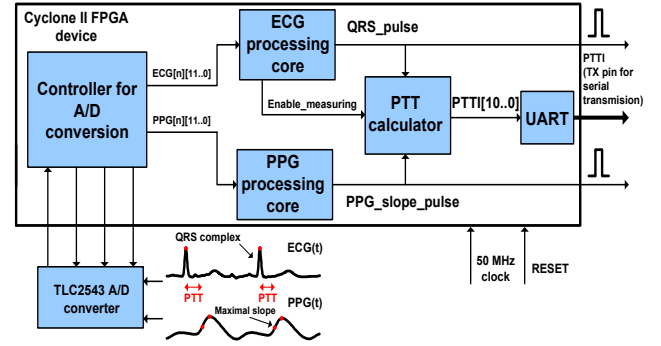

Fig. 4. Block diagram of PTT extraction by FPGA chip.

B. QRS Detection

The internal structure of the *ECG processing core* is given in Fig. 5. The digital samples $ECG[n][11..0]$ are fed to the *Haar DWT* block whose outputs are detail coefficients $D_i(n)[11..0]$ and approximation coefficients $A_i(n)[11..0]$, $i=1..3$. The $D_i(n)[11..0]$, collected during 1s, from all levels, make arrays $D_1[NC_1...1][11..0]$, $D_2[NC_2...1][11..0]$ and $D_3[NC_3...1][11..0]$, $NC_i=1s*f_s/2^i$, $NC_1=400$, $NC_2=200$ and $NC_3=100$. Each of these arrays is then searched by module *Local_min.*, *Local_max.* and *Zero_cross. detector* in order to locate characteristic points, *local_min*, *ZC* and *local_max*. In case of their occurrence in true sequence, the *Pulse_i* is generated. Condition for successful detection of QRS complex is appearance of at least one *Pulse_i* at the inputs of OR gate. Afterwards, the *Final_pulse generator* produces a *QRS_pulse* which is sent out of the *ECG processing core*.

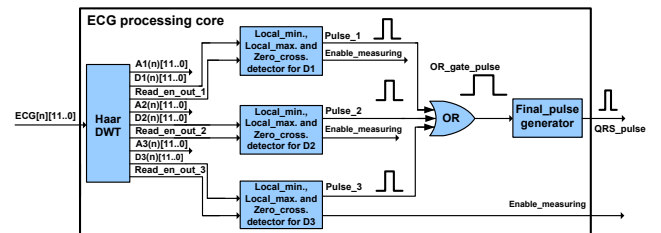

Fig. 5. Internal structure of ECG processing core.

Each module *Local min*, *Local max* and *Zero-cross.* consists of 5 sub-modules: *Local_min.detector*; *Local_max.detector*; *Zero_cross.detector*; *State machine for QRS recognition* and *Pulse generator*, Fig. 6. Operation of *Local_min.detector* and *Local_max.detector* follows the logic from Fig. 7. They generate signals *Min_detected* and *Max_detected*.

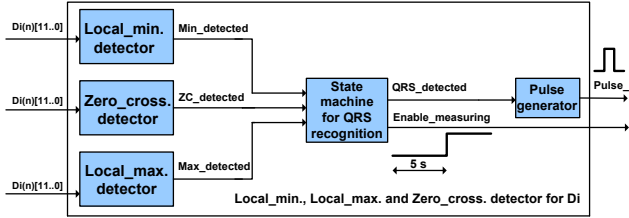

Fig. 6. QRS detection from $D_i(n)$ - structure.

Decision on local min/max is based on adaptive thresholds T_{pi} or T_{ni} and the contents of three registers that contain three successive points $R1=D_i(n)[11..0]$, $R2=D_i(n-1)[11..0]$ and $R3=D_i(n-2)[11..0]$. The decision rules are as following: first, IF $((R3 < R2) \text{ and } (R2 > T_{pi}) \text{ and } (R1 < R2))$ then $Local_max=R2$ and second, IF $((R3 > R2) \text{ and } (R2 < T_{ni}) \text{ and } (R1 > R2))$ then $Local_min=R2$. ZC circuit works under principle $D_i(n)[11..0] > 0$ and $D_i(n-1)[11..0] < 0$ and only sign bits are compared.

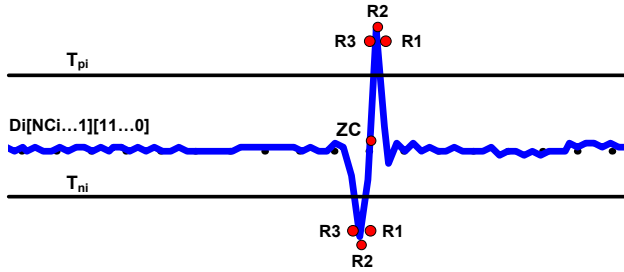

Fig. 7. Finding modulus maxima from $D_i(n)$.

QRS recognition is carried out using a state machine (SM) whose inputs are *Min_detected*, *ZC_detected* and *Max_detected*. The initial state lasts for five seconds and it serves for initial suiting of the adaptive thresholds, Fig. 8. After initial adaptation, the signal *Enable_measuring* becomes high and process of QRS detection begins. Detection of QRS complex is successful if local max is detected after local min and ZC. Then *QRS_detected* synchronized output of SM is generated. *QRS_detected* from SM is fed to the *Pulse_generator*, which generates *Pulse_i* of 30 ms duration. *Pulse_1*, *Pulse_2* and *Pulse_3* are passing through the OR gate creating *OR_gate_pulse* which is in fact the overlapped summation. *OR_gate_pulse* is fed to the *Final_pulse_generator* which produces *QRS_pulse* of 20 ms duration. *QRS_pulse* happens only if between two sequent *OR_gate_pulses* passed 200 ms that is considered as down physiological limit for RR interval.

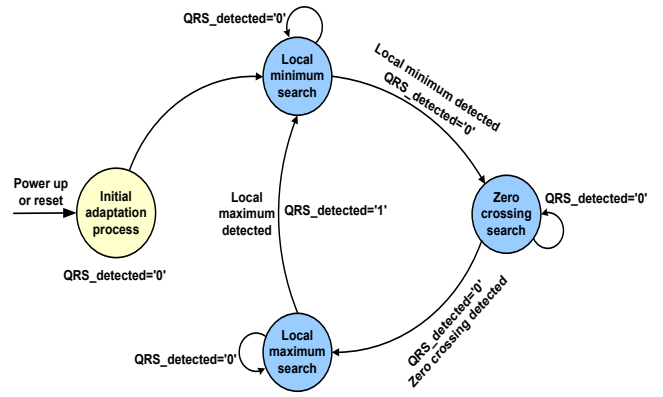

Fig. 8. State machine for QRS detection.

C. PPG Slope Detection

PPG samples, $PPG(n)[11..0]$, are decomposed up to 3^{rd} level. Approximation coefficients $A_1(n)[11..0]$, $A_2(n)[11..0]$ and $A_3(n)[11..0]$ are fed to the derivative filter, producing $D1f_i(n)[11..0]$, $D2f_i(n)[11..0]$ and $D3f_i(n)[11..0]$, and then to the *Max.detector 1*, *Max.detector 2*, and *Max.detector 3*, Fig. 9. The sequences of $D1f_i[NC_1..1][11..0]$, $D2f_i[NC_2..1][11..0]$ and $D3f_i[NC_3..1][11..0]$ ($NC_1=400$, $NC_2=200$, $NC_3=100$) are searched in order to find a local maxima by using thresholding technique. For each $Dif_i(n)[11..0]$, T_i ($i=1..3$) is an adaptive threshold.

Decision rule for local maxima detection for one Dif_i is: IF $((Dif_i(n-2)[11..0] < Dif_i(n-1)[11..0]) \text{ and } (Dif_i(n-1)[11..0] > T_i) \text{ and } (Dif_i(n)[11..0] < Dif_i(n-1)[11..0]))$ then $Local_max=Dif_i(n-1)[11..0]$. When local maxima are detected, pulses *Max_detected_1*, *Max_detected_2* and *Max_detected_3* are generated and fed to state machine, *SM* for detection of maximal slope. This SM has initial state of adaptation of T_i which lasts for five seconds. From *detection state*, after appearance of *Max_detected_1*, *Max_detected_2* or *Max_detected_3*, the SM goes into *PPG_slope_pulse generation state* which lasts for 20 ms. After this state, SM goes into *standby mode* for 180 ms. From *standby mode* SM returns to *detection state*.

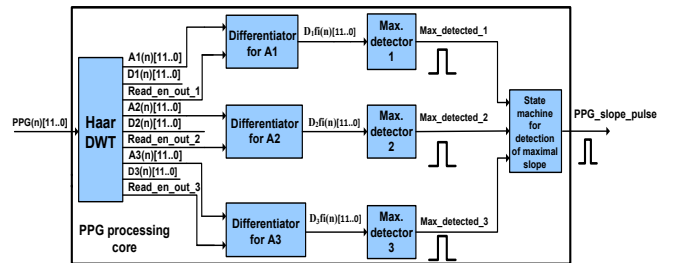

Fig. 9. Internal structure of PPG slope detection core.

D. PTT calculation

The circuit for PTT calculation consists of two counters (*C1* and *C2*), one *latch registers* and *control logic*, Fig. 10. When *QRS_pulse* appears at input of *PTT_calculator*, counters *C1* and *C2* are enabled by control logic. *C1* is clocked by system clock, while *C2* is clocked each 1 ms using overflow (*of.*) of *C1*, and latched by

PPG_slope_pulse. Output of *C2*, N_{ms} represents time elapsed from *QRS_pulse* appearance and it is latched to *PTTI[10..0]* each time the *PPG_slope_pulse* appears.

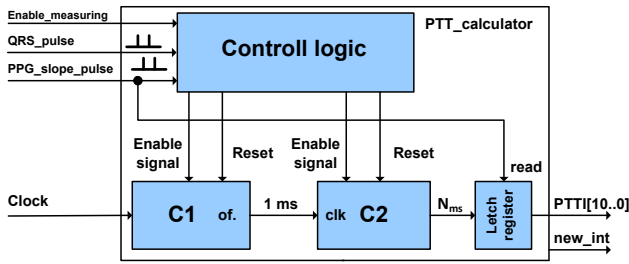

Fig. 10. PTT calculator structure.

IV. TESTING AND RESULTS

Overall system was developed in VHDL code and implemented in Cyclone II FPGA chip EP2C70F896C6N [5]. PTT intervals were transferred out via serial port, while *QRS_pulses* and *PPG_slope_pulses* were observed by oscilloscope.

The records from MIT-BIH Arrhythmia and MIMIC databases were used to test the system. Fig. 11 (a) shows the oscillograph of ECG signal and digital pulses, *QRS_pulses*, at output of the QRS detector, at the pin of the FPGA chip. Fig. 11 (b) shows the result for the detection of maximal slopes in PPG signals. QRS detector test was conducted on 10 records from MIT-BIH Arrhythmia database and it lasted for five hours. Testing was conducted on a total of 22031 beats, where there were 105 false detections and 424 missed detections. The average accuracy of the QRS detector is 97.53%. PPG processing core was tested on records from MIMIC database. 5 x 10-minute PPG records were examined, achieving average detection accuracy was 97.09%.

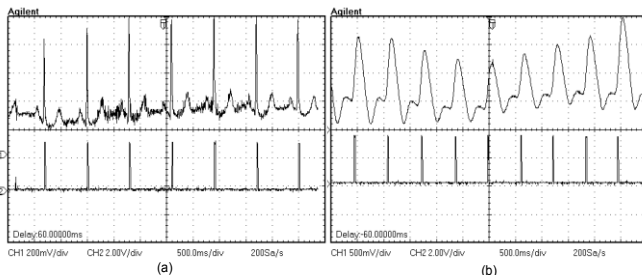

Fig. 11. (a) QRS detection from ECG (b) MS detection from PPG.

PTT calculation was tested on records from MIMIC database. ECG and PPG signals were processed in parallel in order to extract PTT intervals. Fig. 12 shows result for calculation of PTT intervals for MIMIC record no. 041 and confirms inverse correlation between PTT and systolic BP.

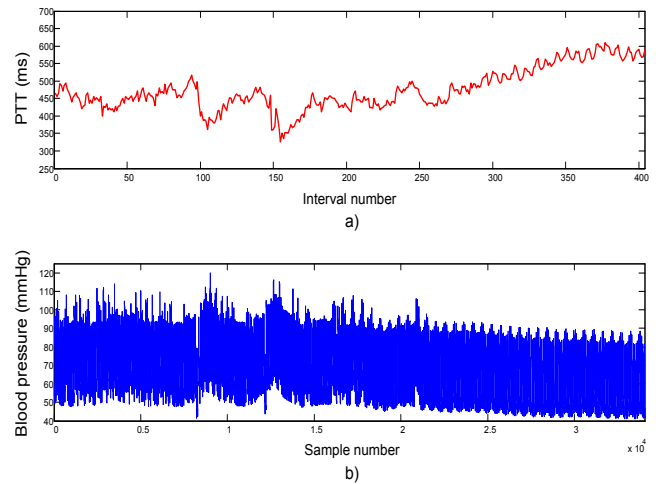

Fig. 12. (a) PPT intervals and their correlation with (b) BP signal.

V. CONCLUSION

A system and methodology for real-time ECG and PPG processing and PTT interval calculation are presented. All tasks are implemented in a single FPGA chip. The system is achieving an accuracy of more than 97% for ECG and PPG signals. As such, it is ideal for embeded systems or wearable health care devices where cuff-less measurement of blood pressure is necessary.

REFERENCES

- [1] WHO, "Cardiovascular diseases (CVDs)", Fact sheet N°317, March 2013, accessible at <http://www.who.int/mediacentre/factsheets/fs317/en/>.
- [2] M. H. Voelz, C. F. Babbs, J. D. Bourland, "Pulse Transit Time as an Indicator of Arterial Blood Pressure ", *Psychophysiology*, vol. 18, pp. 71-74, 1980.
- [3] S.G. Mallat, "A theory for multiresolution signal decomposition: the wavelet representation", *IEEE Trans. Pattern Analysis and Machine Intelligence*, vol. 11, no. 7, pp. 674-693, 1989.
- [4] R. Stojanović, D. Karadaglić, M. Mirković, D. Milošević, "A FPGA system for QRS complex detection based on integer wavelet transform", *Measurement Science Review*, vol. 11, issue 4, pp. 131-138, 2011.
- [5] Altera Corporation, www.altera.com.