

Laser Cutting and Welding Tools for use In-bore on EU-DEMO Service Pipes

K. Keogh^{a*}, S. Kirk^a, W. Suder^b, I. Farquhar^a, T. Tremethick^a, A. Loving^a

^aUnited Kingdom Atomic Energy Authority, Culham Science Centre, Abingdon, OX14 3DB, UK

^bCranfield University, College Road, Cranfield, Bedfordshire, MK43 0AL, UK

Replacement of blanket modules and divertor cassettes in the EU-DEMO will require rapid removal of hundreds of service pipes during maintenance downtime. Duration analysis of conventional joining processes, estimate cutting and welding would account for ~60% of EU-DEMO remote maintenance. To minimize duration, laser cutting and welding tools have been developed for use within these pipes. The tools consist of a mechanical system to position the tool and the pipe correctly, and a miniaturized laser optics package to apply the process around the entire pipe circumference. Prototypes of the optics for the cutting and welding tools were produced, and the laser processing performances were assessed. Here, we will present the concept and prototype designs of the laser cutting and welding tools, the results of the prototype tool trials, and how the tools fit within the overall remote maintenance strategy for EU-DEMO, highlighting the duration reduction compared to conventional techniques.

Keywords: EU-DEMO, Remote Maintenance, Laser Welding, Laser Cutting, Service Pipes

1. Introduction

The EU-DEMO tokamak will be a first-generation fusion plant to output electrical power and breed its own tritium fuel. EU-DEMO first wall components will require active cooling during operations and a breeding fluid which will be used in tritium production and transportation. The specifics of the fluid requirements are dependent on the final blanket design. For the purpose of this work it is assumed there will be fluids and they will be delivered through a collection of service pipes connecting in-vessel components to the plant.

The EU-DEMO baseline proposes all service pipes and component extraction utilise existing ports in the vessel. The breeding blankets will be removed and replaced by a vertical extraction process through the vertical port. (See Figure 1). The divertor cassettes will be removed through the lower port. The service pipes to these components will need to be disconnected and removed from the ports for regular maintenance, this maintenance cycle has been detailed in [1]. Due to the number of pipes and diameters required for each in vessel component, there are significant space constraints in the port.

2. EU-DEMO Pipe Layout and Environment

The Remote Maintenance (RM) development work is based on a developing RM baseline model development in 2015 [2]. The RM baseline diverges from the current EU-DEMO baseline, due the need to have fixed values for components requiring handling, and the principles developed here will remain relevant to handle the actual EU-DEMO components.

The RM concept for EU-DEMO service pipes, which is based on historical work from 2012 [3], has resulted in the number of pipes that are expected to be separated and joined are 784 pipes per reactor maintenance cycle. This estimate is based on conceptual designs for a 16-port model, with five blankets and three divertors per sector.

The pipe distribution estimates can be seen below in Tables 1 and 2. During the RM cycle it is expected that all in-vessel components and pipes will be completely replaced.

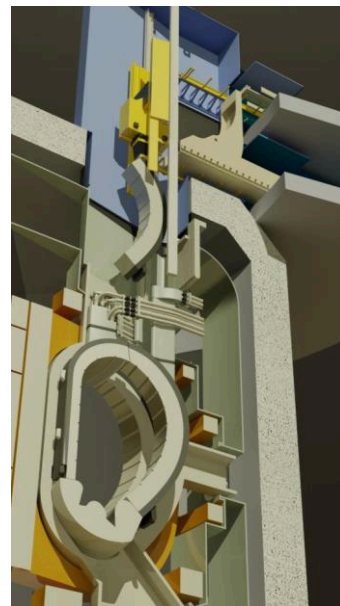

Fig. 1: Vertical port blanket extraction handling scheme

Table 1. Blanket pipe distribution

Pipe use	Number of Pipes per upper port	Pipe Inner Diameter (mm)	Pipe Wall Thickness (mm)
Coolant per Blanket LiPb	4	200	15
Breeder per Blanket	2	75	5
Coolant per neutron shield	2	80	5

Keelan.keogh@ukaea.uk

Table 2. Divertor pipe distribution

Pipe use	Number of Pipes per Divertor port	Pipe Inner Diameter (mm)	Pipe Wall Thickness (mm)
Water			
Coolant per Divertor	4	80	5
Drain pipe per Blanket	1	80	5

The positioning of the magnets limits the size of the ports; this in addition to the number of pipes, results in no external access to the pipes [1]. The RM pipe layout can be seen in Figure. 2. For deployment the pipes are grouped into enclosed modules, one for each in-vessel component. Any tool design will be required to be scalable to the various pipe diameters and remotely provide all functionality needed, specifically swiftness of operation to maintain a viable maintenance duration.

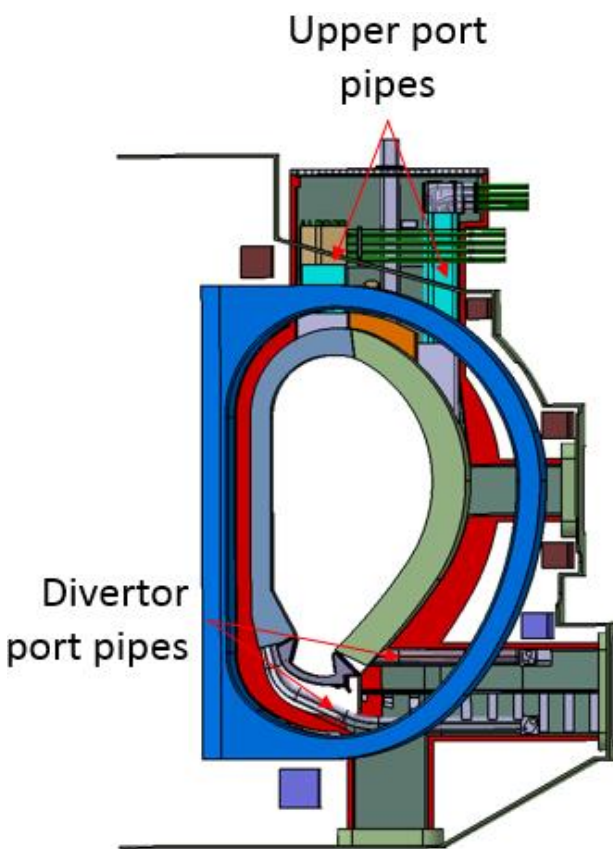

Fig. 2: Port with pipe locations

The pipe alignment will be assisted by dowel pins connected to the pipe modules; once the pipes are in position the tool will be deployed to perform the final alignment working with the pipe feature. This feature can be seen in Figure. 3.

The RM concept includes a bend in the divertor port pipes of 1500 mm bend radius. This is required to connect the inner wall blankets drain pipes to the plant.

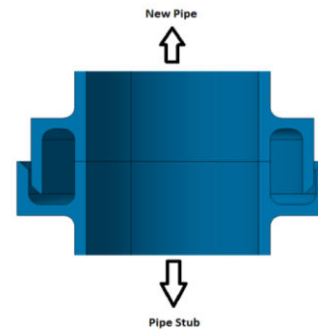

Fig. 3: Pipe alignment feature

2.1 Timing Duration

Due to the number of pipes, various processing techniques were investigated to identify the most suitable for further research. Laser processing was chosen after comparing it to conventional methods due to the advantages of high depth of penetration and speed of welding as key factors [4].

Conventional TIG welding and non-lubricated cutting is used as the baseline, as it is used on JET and ITER maintenance solutions [5,6]. Using the DEMO Maintenance duration tool developed by RACE [7], a clear advantage can be seen in laser processing regarding speed of process. Particularly in the cutting duration as seen in Tables 3 and 4. As an example, using conventional cutting processes on the large DEMO pipe diameters and thicknesses an estimated duration of cutting of ~1.5 hour per 200 mm pipe, compared to laser cutting of ~30 seconds.

Table 3. Comparing welding operations per port

	TIG Welding	Laser Welding
Total Welding operation	148 hours	121 hours
Total port Assembly	330 hours	312 hours

Table 4. Comparing cutting operations per port

	Mechanical Cutting	Laser Cutting
Total Cutting operation	488 hours	5 hours
Total port Clearance	700 hours	217 hours

With this difference the total DEMO maintenance cycles change from eight months with conventional technologies to five months using laser processing. The target DEMO maintenance cycle is expected to be six months. This shows a clear advantage to reduce the DEMO service joining durations by using a laser processing.

Though the laser based processes are much faster the peripheral service joining activities: deployment, inspection, and Post Weld Heat Treatment (PWHT) remain the same. This prevents major savings in welding duration.

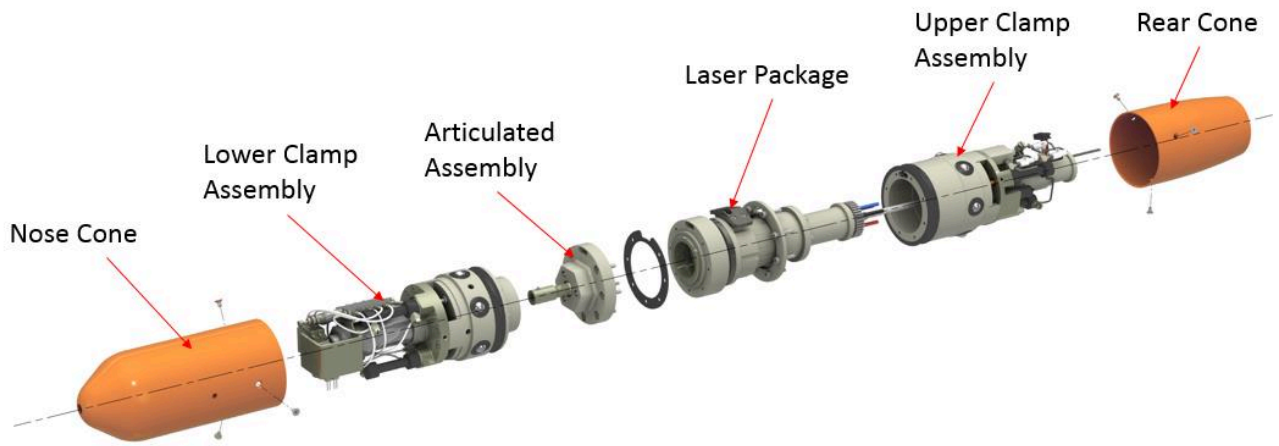

Fig. 4: Exploded proof of principle tool design

3. EU-DEMO Pipe Tool Concept

The concept pipe tool for EU-DEMO [8] uses two separate tools with common features. A cutting tool and a welding tool, the difference between both tools is found in the optics design and the focused processing gas systems. The concept operation of the tool is; the tool is inserted in a pipe; deployed to location; it then secures to the pipe wall; performs a laser process; and is extracted.

In the development of the tooling design a Proof of Principle (PoP) model for both the cutting and welding tooling has been developed Figure. 4.

To create a PoP tool capable of all relevant features the following features were identified to be demonstrated in a PoP tool:

1. Inspection capability
2. A stable platform
3. Quantify waste generated
4. Minimal pipe bend radius
5. Tool fits inside the smallest relevant pipe diameter
6. Laser processes can be achieved
7. Alignment of pipe faces

The PoP tool design achieves all the DEMO tool features utilising commercially available components such as standard: pneumatics, high power fibre connectors, optics lens, high torque motors. This has resulted in the PoP tool design capable of fitting inside a standard DN 90 Sch 40 pipe (90 mm ID, 5 mm wall thickness).

3.1 Clamping system

At each end of the tool there is a clamping system, the clamping system consists of a pneumatically driven tapered ring that deploys 6 ball bearings into a mating datum feature in the pipe. When the clamp is released the ball bearings are loose acting as wheels, allowing the tool to roll through the pipe during deployment. When engaged in the pipe feature the clamping strength is dependent on the yield force of the steel components. The clamping also acts a reaction force to locally draw the pipes together, by using the central cylinder needed for pipe manipulation.

3.2 Articulation system

The articulated assembly in the centre of the tool uses a balled hex design. This geometric shape prevents rotation of the tool axially but allows the tool to pitch in any direction up to 10°. This allows the tool to travel around a pipe bend of 1500 mm. This combined with the ball bearings of the clamping system allows the tool to travel through the service pipes.

3.3 Laser package

The laser package is the tool payload; it is rotated by an electrical motor housed in the upper clamp section. This motor rotates the head equating to a travel speed of 0.5-1.5 m/min. The laser package focuses the laser delivered through a high-power fibre, creating the required spot for processing of 0.2–0.6 mm (See Figure 8) through a bespoke optics set up. Two attached endoscope cameras allow visibility of the pipe fit-up and laser processing.

The laser packages also concentrate the gases onto the process zone. These gases are used as optics coolant before they are used for processing. A focused cutting gas is directed onto the cutting spot in the cutting package. In the welding package the gas is used to create an inert environment around the weld and create a gas knife over the optics protecting the optics from debris created in the process.

3.4 Pipe manipulation

There is also a large pneumatic actuator in the lower section. Once the tool is clamped to the pipe the actuator allows it to pull them together or apart, during welding and cutting. This is to ensure during welding specifically that the line-up of the pipes faces is ideally 0.1 mm apart to ensure a good weld. The tool is designed to be used in conjunction with an external pipe alignment feature seen in Figure. 3. This feature provides the gross alignment of the pipe within millimetres of optimal the tool then has capability to perform the finally manipulation of the pipes.

The cutting tool can apply a tension to the pipes during processing to ensure separation of the pipes and prevent molten waste re-joining the pipes.

4. Proof of Principle results

The key technological risk identified during tool development was that of the miniaturised optics compared to standard off the shelf optics packages. Testing of the principles of joining have been performed with a standard welding head at the Welding Engineering and Laser Processing Centre (WELP) at Cranfield University to identify material and process compatibility; followed by a testing of the custom optics head tested at TWI to; quantify the thermal response of the optics; the processing gas delivery as cutting and welding requires; and investigate the power distribution capable from the optics.

4.1 Process design tests

Tests at WELP were performed with a standard “Precitec” head creating a single beam weld which demonstrated the capability of welding Eurofer 97 with high power laser processing and comparing it to welding of standard available P91, this can be seen in Figure 5. As can be seen in the cross sections both materials create similar appearing welds. These welds were performed on 6 mm plate at 4 kW with a spot size of 0.6 mm and 0.5 m/min travel speed [9].

These welds were examined for mechanical properties, and seen to be similar in all tests. The weld hardness has shown to have increased significantly above the parent material, further investigation into a Post Weld Heat Treatment (PWHT) is required for Eurofer 97 [10], to return the material to its original properties.

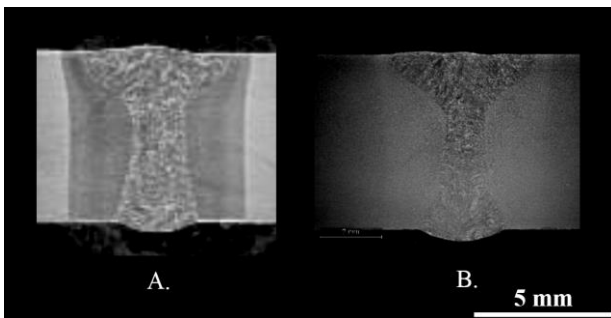

Fig. 5: Process test weld samples (A.) Eurofer97 (B.) P91

4.2 Optics head trials

To gather empirical data for the concept, the design of the bespoke optics was manufactured and mounted in a special holder. At TWI this holder was mounted to a “Kawasaki” articulated arm and positioned over material samples as seen in Figure 6. The optical fibre was then connected to an IPG YLS-5000 laser system. The material samples were held in a special jig positioning the pipes against each other, in Figure 6 one half of a weld sample can be seen with the tool in its mount positioned inside.

During the bespoke optics testing the key areas of investigation were:

- thermal response of the system
- ability of the shielding gas to protect optics
- optics performance

These tests were performed on both the cutting and welding tooling, with the thermal response monitored.

The optics thermal response showed minimal temperature increase of the process duration. The optics in the processing heads are gas cooled utilizing the process gas. The thermocouple readings showed a peak temperature delta in the welding tool of 5°C which returned to room temperature after 30 seconds of cooling. No thermal damage was caused to the optics.

The welding tool was successful in creating thin wall 1.2 mm carbon steel welds as well as partial penetration 5 mm thick, 316L and P91, 90 mm pipe and plate welds. These thick wall welds have been cross-sectioned and show penetration depths of 2.5 mm and 2.8 mm in 316L and P91 pipes respectively Figure 7.

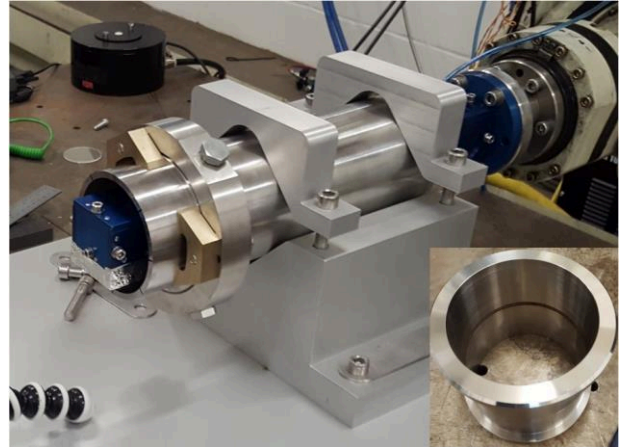

Fig. 6: Bespoke optics testing bed at TWI (inserted welded pipe sample)

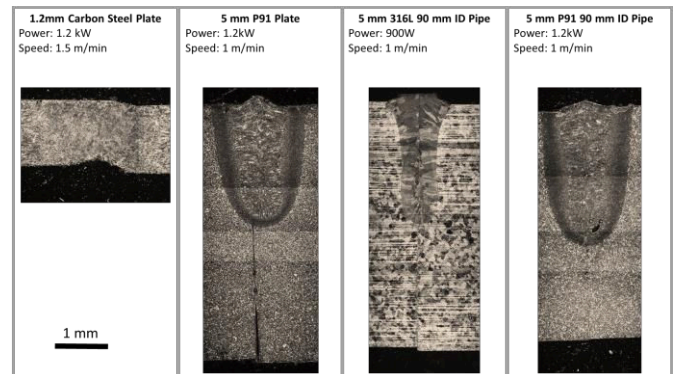

Fig. 7: Cross-section results of plate and pipe welds

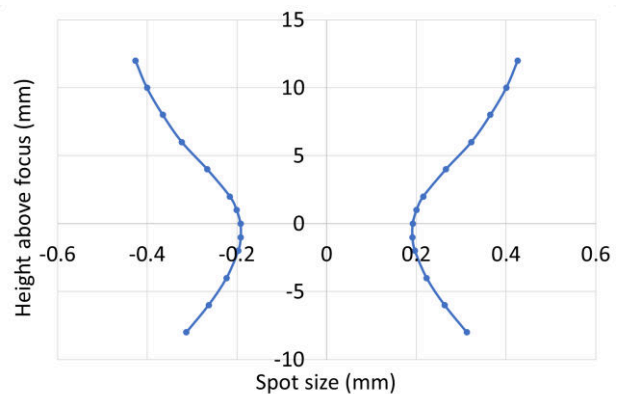

Fig. 8: Laser divergence profile produced by bespoke optics at 45 mm stand off

These welds were performed with 1.2 kW power with a nominal 0.4 mm spot size (See Figure 8), travelling at 1 m/min. The laser spot size and divergence produced by the optics was measured using a profilometer prior to processing samples. The optics produce a focused spot with a 45 mm offset distance of diameter 0.38 mm, suitable for cutting and welding. The spot is still less than 0.45 mm diameter ± 3 mm of nominal focus point as seen in Figure 8.

5. Conclusions

Due to the high expected number of pipes, the overall viable remote maintenance window is dependent on processing of the service pipes. Laser processing has been identified as a feasible and rapid technology option that can be used to join and separate the DEMO pipes.

The concept design of the service joining tooling has been designed with laser processing into a proof of principle tool combining various technologies using off the shelf components. The processing of DEMO relevant materials with high power fiber lasers has been demonstrated with the Cranfield experiments. Highlighting the material limitations of Eurofer 97 requiring extensive heat treatment processes.

The bespoke optics package has been tested at TWI demonstrating the capability of the optics for short durations. The combination of these technologies and principles has demonstrated a potential DEMO solution.

6. Further work

This work is part of an ongoing project to develop a full service joining system relevant for a DEMO environment. In the near term the planned work is:

- Testing of the mechanical functions of the PoP tools actuators
- Increasing the power through the bespoke optics set up
- High power cutting with the bespoke optics

Acknowledgments

The Authors would like to thank Dr. Supriyo Ganguly, Cranfield University, for his advice on this work and Dr. Chris Allen, TWI, for his assistance and advice performing trials with the bespoke tools. The authors would also like to thank Samuel Ha, UKAEA, for his work and assistance with conceptual work on cutting technology when developing this work.

This work has been carried out within the framework of the EUROfusion Consortium and has received funding from the Euratom research and training programme 2014-2018 under grant agreement No 633053 and from the RCUK Energy Programme [grant number EP/I501045]. The views and opinions expressed herein do not necessarily reflect those of the European Commission.

References

- [1] R. Buckingham and A. Loving, "Remote-handling challenges in fusion research and beyond," *Nature Physics*, vol. 12, pp. 391-393, 2016.
- [2] J. Davis and V. Agudo, "Concept Design Description for the DEMO Upper Port Maintenance System," RACE, EFDA_D_2MMR6P, 2015.
- [3] M. Westall, "Assesment of the feasibility of in-bore cutting, welding and testing for DEMO Blanket service pipes," CCFE, 2012.
- [4] J. C. Ion, *Laser Processing of Engineering Materials*, Elsevir, 2005.
- [5] D. Locke, "JET Remote Handling Requirements," CCFE, 2006.
- [6] L. Thomson, J. Woodwark and et. al, "Neutral beam remote cutting & welding development," *Fusion Engineering and Design (In preperation)*, 2017.
- [7] I. Farquhar, "AWP2016-RM-2-T002 RM Systems Integration 2016," RACE, 2016.
- [8] K. Keogh, "RM-5.1.1-T002-D003 PD22-Concept Design for the Bore Pipe Welding Tool," RACE, 2015.
- [9] W. Suder, S. Ganguly, K. Keogh and S. Kirk, "Fabrication of advanced structural steels for fusion reactors by laser-laser hybrid processing," *ISFNT (In preperation)*, 2017.
- [10] S. Kirk, W. Suder, K. Keogh, T. Tremethick and A. Loving, "Laser Welding of Fusion Relevant Steels for the European DEMO," *In preperation*, 2017.