

## Physicochemical characterization of Saccharides Powder Obtained from Yacon Roots (*Smallanthus sonchifolius*) by Membrane Technology

Maria Julia Ledur Alles<sup>1</sup>, Isabel Cristina Tessaro<sup>2</sup> and Caciano Pelayo Zapata Noreña<sup>1\*</sup>

<sup>1</sup>Instituto de Ciência e Tecnologia de Alimentos; Universidade Federal do Rio Grande do Sul; Porto Alegre - RS – Brasil. <sup>2</sup>Departamento de Engenharia Química; Universidade Federal do Rio Grande do Sul; Porto Alegre - RS – Brasil

### ABSTRACT

Fructooligosaccharides (FOS) are food ingredients applied due to combination of prebiotic benefits and interesting technological properties, being used as a sugar substitute. The knowledge of their physicochemical characteristics is important for predicting the stability of the food products where they are added. For this reason, a saccharides powder extracted from yacon (*Smallanthus sonchifolius*) roots by membrane technology and freeze-dried was investigated. Color, water activity ( $a_w$ ), microstructure by Scanning Electron Microscopy coupled to Energy-dispersive X-ray Spectroscopy (SEM-EDS) and crystallinity by X-ray diffraction were evaluated. The obtained product, containing 19.75% FOS, 36.66% glucose and 43.59% fructose (w/w) was a whitish granulated powder, with  $a_w$  of 0.284 and CIELAB color coordinates  $L^*$ ,  $a^*$  and  $b^*$  of  $76.25 \pm 1.19$ ,  $-1.03 \pm 0.09$  and  $1.02 \pm 0.03$ , respectively. It was highly hygroscopic and with agglomeration tendency, confirmed by the formation of bridges between particles on the SEM images. No peaks were identified at X-ray diffractograms, indicating its amorphous characteristics, but sample high hygroscopicity and formation of a rigid mass might have hampered a trustable X-ray analysis.

**Key words:** yacon, fructooligosaccharides, microstructure, cristallinity

### INTRODUCTION

Nowadays, the strong relationship between the diet and health is well accepted. In this regard, functional foods play an outstanding role. Besides exhibiting an adequate nutritional value, a food can be considered functional if it beneficially affects one, or more target functions in the body in a way to prevent nutrition-related diseases, or improve consumers' physical and mental well-being (Siró et al. 2008; Figueroa-Gonzalez et al. 2011). The functional foods market was estimated to reach US\$ 167 billion after 2010, with an yearly growth potential of 10% (Granato et al. 2010).

Probiotics and prebiotics, fundamental ingredients of fermented milks and yogurts, account for the most important fraction of the overall market for functional foods (Figueroa-Gonzalez et al. 2011), probably related to the growing evidence of colonic microbiota positive influence on health (Wang 2009). Fructooligosaccharides (FOS), also known as oligofructose, are considered prebiotic because they are not hydrolyzed by human intestinal digestive enzymes and reach the colon intact, where they are selectively fermented by the probiotic bacteria such as Lactobacilli and Bifidobacteria (Jenkins et al. 1999; Tuohy et al. 2001; Kolida and Gibson 2007), contributing to a

\* Author for correspondence: czapatan@ufrgs.br

more balanced composition of intestinal microbiota (Menne and Guggenbuhl 2000; Rao 2001; Guigoz et al. 2002; Veereman 2007; Waligora-Dupriet et al. 2007). They are oligomers with degree of polymerization (DP) between 3 and 10, consisting mainly of  $\beta$ -(2 $\rightarrow$ 1) fructosyl-fructose linkages, sometimes containing a starting  $\alpha$ -D-glucose moiety. It is the  $\beta$ -configuration of the anomeric C2 in their fructose monomers that affects the digestibility, because human enzymes are specific for  $\alpha$ -glycosidic bonds (Kolida and Gibson 2007; Roberfroid 2007).

FOS are considered food ingredients and used in many food applications due to the combination of nutritional benefits and technological properties closely related to those of sugar and glucose syrups. They are highly soluble and often used in combination with high intensity sweeteners. Commercially available FOS are obtained by partial enzymatic hydrolysis of inulin extracted from chicory roots using an endo-inulinase, or by synthesis from sucrose using fructosyl-transferase. They are presented as a colorless viscous syrup (75% dry substance, or a spray-dried powder (Franck 2002). There are, however, some reports on their extraction from other sources such as Jerusalem artichoke (Lingyun et al. 2007; Panchev et al. 2011), dahlia tubers (Anan'ina et al. 2009) and yacon roots (Kamada et al. 2002).

Yacon (*Smallanthus sonchifolius*) is a perennial plant originated from the Andean region, whose roots outstand by storing the carbohydrates in the form of FOS, especially 1-kestose (GF<sub>2</sub>), nystose (GF<sub>3</sub>) and 1- $\beta$ -D-fructofuranosylnystose (GF<sub>4</sub>), instead of starch (Ojansivu et al. 2011). There are also 15-40 % of simple sugars such as sucrose, fructose and glucose. Other nutrients are reported to be low, except for potassium (Lachman et al. 2004). FOS extraction from yacon roots may be performed by membrane technology, a potential feasible strategy for industrial manufacture of oligosaccharides (Goulas et al. 2002; Kuhn et al. 2010) that have been used successfully for their purification (Minhalma et al. 2006; Nabarlantz et al. 2007; Sjöman et al. 2007; Catarino et al. 2008).

Commercializing FOS in the powder form has the advantage of facilitating manipulation, transport, storage and consumption. However, variations on FOS powder's moisture content may cause undesirable physical changes such as caking, or agglomeration (Figueira et al. 2004). For this reason, the determination of parameters such as water activity ( $a_w$ ) is important to understand the

physicochemical changes mechanisms in food products and predict their stability. The caking phenomenon on a polysaccharide surface can be observed by Scanning Electron Microscopy (SEM), which allows the visualization of the formation of solid bridges between the adjoining particles (Ronkart et al. 2006). It is well established on various well-known products, such as sucrose, trehalose, starch, or dairy products that the degree of crystallinity greatly affects the stability, or the utilization in many domains, e.g., food industry, or pharmaceuticals (Ronkart et al. 2007). The crystallinity of the product has an impact on the flowability of the powder during the storage (i.e., caking) and on its water absorption properties (Ronkart et al. 2006). Powder X-ray diffraction has been used to understand the crystallization behavior of the amorphous fraction of polysaccharides, relating it to the physical state and glass transition temperature (Zimeri and Kokini 2002; Kawai et al. 2011).

Thus, the objective of this work was to evaluate the physicochemical characteristics of a saccharides powder, obtained from yacon roots by combining ultrafiltration (UF) and nanofiltration (NF) and freeze-dried, describing its characteristics for color, microstructure and crystallinity degree and comparing them to commercial samples of FOS and inulin.

## MATERIALS AND METHODS

### Commercial fructooligosaccharides sample

Commercial fructooligosaccharides were supplied by Beneo Orafit and, according to information provided by the manufacturer, were produced by partial enzymatic hydrolysis of chicory inulin. They were in form of a spray-dried fine white powder with purity  $\geq 93.2\%$  on dry matter basis (glucose + fructose + sucrose  $< 6.8\%$ ) and degree of polymerization between 2 and 8.

### Yacon roots

The yacon (*Smallanthus sonchifolius*) roots were cultivated in São Paulo State, Brazil, and acquired from the Supply Centre of the Rio Grande do Sul State in the city of Porto Alegre, Brazil. The roots were cleaned and selected considering the absence of visible injury and infection and were stored under refrigeration ( $8 \pm 2^\circ\text{C}$ ) until used, for not more than three weeks.

### Yacon saccharides powder production by membrane processes

The yacon extract used in the UF-NF processes was prepared in two steps, adapting the methodology described by Toneli et al. (2007). Firstly, yacon roots were sliced and kept for 20 min in a 0.5% sodium metabisulphite solution for minimizing yacon enzymatic darkening (Padilha et al. 2009). After soaking, samples were washed using distilled water. Next, the roots were ground in a food multiprocessor and the extracted juice was kept refrigerated. After this, residual saccharides were extracted from the ground roots by lixiviation through the addition of 80°C water in a proportion of 2 L of water to 1 kg of ground roots. This mixture was kept at an average temperature of  $80 \pm 2^\circ\text{C}$  for 1 h and then filtered through a 270 mesh sieve for removing the yacon triturated roots. The two yacon fractions - the juice and the liquid extracted from the ground roots - were then filtered using a 1  $\mu\text{m}$  nominal pore sizes filter and mixed, resulting in the yacon extract.

The yacon extract was processed in two stages, combining UF and NF cross-flow processes, according to the methodology described by Kamada et al. (2002). It was first subjected to batch UF processing (30 kDa polymeric membrane, DBO Filters), recirculating the retentate to the feed tank in order to remove the large molecules such as protein, starch, fibers and suspended substances, yielding a saccharide-rich permeate. The concentration-mode experiments were performed at a transmembrane pressure of 0.75 bar and 25°C, controlled by the water-cooling the feed tank (these operating conditions were determined in previous experiments). UF process was conducted until the amount of retentate became less than the hold-up volume and could no longer be recycled, which took approximately 200 min. The initial feed volume was reduced by half. In the second stage, the UF-permeate was processed by NF (1000 Da regenerated cellulose membrane, Millipore), also in a batch mode with full recycling of retentate, in order to concentrate the oligosaccharides in the retentate and reduce glucose, fructose, sucrose and salts concentration. This operation was done in association with a discontinuous diafiltration (DF) mode, which consisted of adding incremental volumes of distilled water to retentate aiming to optimize the salts, mono and disaccharides withdraw in the permeate while removing this added volume, increasing the degree of FOS purification. Every

time permeate volume reached 50 mL, the same volume of water was added to retentate, totalizing 200 mL of added water. The NF experiments took approximately 300 min under a transmembrane pressure of 4.5 bar, also determined in previous experiments. Experiments were performed in a pilot plant, WGM-KOCH PROTOSEP IV, shown schematically in Figure 1.

The NF-retentate was frozen at  $-40^\circ\text{C}$  in an ultrafreezer (Terroni, São Carlos, Brazil) and freeze-dried at  $-40^\circ\text{C}$  and 100  $\mu\text{mHg}$  (13.3 Pa) (LS6000 Lyophiliser, Terroni, São Carlos, Brazil). The obtained powder was kept in a desiccator until use.

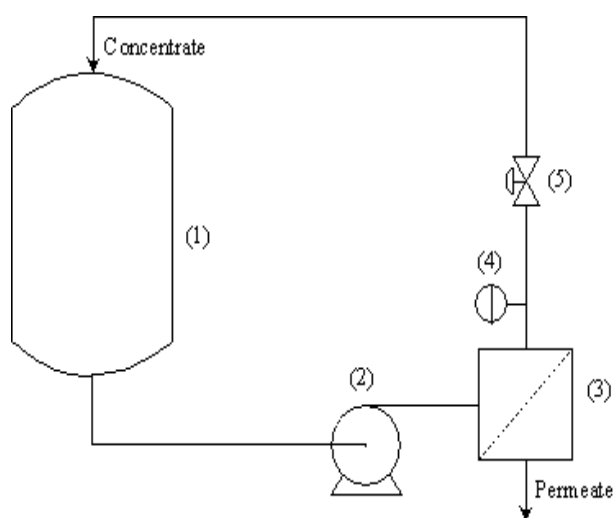

**Figure 1** - Schematic representation of the membrane bench scale unit. Legend: (1) tank, (2) pump, (3) membrane module, (4) manometer and (5) valve for pressure control.

### Saccharides content determination by HPLC

The saccharides content (FOS, glucose and fructose) in final NF-retentate was evaluated by the high performance liquid chromatography (HPLC) as described by Zuleta and Sambucetti (2001) and Scher et al. (2009), using a Perkin Elmer series 200 chromatograph equipped with a refractive index detector (HPLC-RI) (PerkinElmer Life and Analytical Sciences, Shelton, CT, USA) and ultrapure water as the mobile phase at  $0.6 \text{ mL} \cdot \text{min}^{-1}$ , temperature of  $80^\circ\text{C}$  and a Phenomenex Rezex RHM monosaccharide column, 330 mm  $\cdot$  7.8 mm, with a total run time of 14 min. Reference sugars (glucose, fructose and inulin) were purchased from Sigma-Aldrich. Calibration curves were plotted with 0.005-

4.0 g/100 mL for all the sugars. The retention times were 6.766 min for oligofructose, 9.946 min for glucose and 10.742 min for fructose. All the injections were carried out in duplicate.

#### Color measurement

The color of yacon saccharides powder and of commercial inulin and FOS samples was measured directly in the powder at three different locations by using a Minolta colorimeter (Chroma Meter CR400/410) after standardization with a white calibration plate ( $L^*=97.47$ ;  $a^*=0.08$ ;  $b^*=1.76$ ) (Rosell et al. 2009). The color was recorded using the tridimensional CIEL\*a\*b\* system, where  $L^*$  indicated the luminosity (varying from 9=black to 100=white),  $a^*$  was a measurement varying from green (-60) to red (+60) and  $b^*$  varied from blue (-60) to yellow (+60).

#### Scanning Electron Microscopy and Energy-dispersive X-ray Spectroscopy

The microstructures of the yacon saccharides powder and of commercial FOS were visualized by the SEM using the method recommended by Toneli et al. (2008), which consisted of weighing approximately one gram of sample onto double faced adhesive tape fixed to a metal stub. The samples were viewed under the equipment TM3000, Hitachi High Technologies Corporation (Tokyo, Japan) operating at 15 kV. The microscope was equipped with the energy-dispersive X-ray spectroscopy (EDS) system SwiftED3000, Oxford Instruments, allowing powders chemical characterization by elemental analysis. EDS is a technique coupled to SEM able to analyze the atomic composition of a sample and presents the advantage to permit the observation of the sample by SEM before making the analysis (Murrieta-Pazos et al. 2012).

#### Water activity ( $a_w$ )

The water activity was measured using a dew point hygrometer, Aqualab 3TE-decagon device (Pullman, USA) according to AOAC method n. 978.18 (1).

#### X-ray diffraction

X-ray diffraction analyses were performed adapting the method described by Ronkart et al. (2006), Kawai et al. (2011) and Panchev et al. (2011). Patterns of saccharides samples (in powder form) at room temperature were registered on Bruker D2 Phaser diffractometer (Bruker AXS,

Karlsruhe, Germany) with Cu  $K\alpha$  radiation ( $\lambda=0.5418$ ), generated by an anode device operating at 30 kV and 10 mA. X-ray diffraction spectra were collected within the  $2\theta$  range from  $5^\circ$  to  $45^\circ$  with a constant step of  $0.02^\circ$  and counting time of 1 s/step.

## RESULTS AND DISCUSSION

#### Yacon saccharides powder

The obtained yacon saccharides powder contained (%) 19.75 FOS, 36.66 glucose and 43.59 fructose (w/w). It was a whitish granulated powder, sticky, highly hygroscopic and with agglomeration tendency. The hygroscopic behavior was probably related to the high content of fructose and glucose content, reducing sugars that counted for 80.25 % of the saccharides mixture in weight and known for their hygroscopicity, mainly fructose (Davis 1995). These sugars are responsible for strong interactions with the water molecules due to polar hydroxyl groups that also influence the solubility properties (Maia and Cal-Vidal 1994). Commercial FOS also presented a slight hygroscopic behavior, but in much less extent, which could be related as well to the small reducing sugars content - as informed by the manufacturer, glucose, fructose and sucrose represented less than 6.8% of the powder.

The higher water content of the experimental yacon saccharides powder was confirmed by the water activity measurement. While yacon FOS presented  $a_w$  of 0.284, the commercial chicory FOS  $a_w$  was 0.138. This result could similarly be related to the higher content of reducing sugars in experimentally obtained samples related to commercial ones. It could also be related to the drying method. Ahmed et al. (2005) observed that freeze-dried samples rapidly adsorbed the moisture compared to the control sample (without freeze-drying).

Results from the color measurements indicated that for the experimentally obtained yacon saccharides powder the rectangular coordinates  $L^*$ ,  $a^*$  and  $b^*$  were  $76.25\pm1.19$ ,  $-1.03\pm0.09$  and  $1.02\pm0.03$ , respectively. For the commercial chicory FOS, these values were  $96.86\pm0.57$ ,  $-0.05\pm0.04$  and  $0.69\pm0.14$ , respectively. Rosell et al. (2009), measuring inulin powder color, observed the values of  $85.57 \pm 0.37$  for  $L^*$ ,  $-1.23 \pm 0.06$  for  $a^*$  and  $7.04 \pm 0.06$  for  $b^*$ . According to the color measures, yacon saccharides powder was

neither as white as the commercial FOS nor as inulin powder evaluated by Rosell et al. (2009) due to the smaller  $L^*$  value. The negative value for  $a^*$  indicated that the experimentally obtained sugar mixture's color tended to green and was greener than the commercial FOS due to the smaller  $a^*$  value. The positive  $b^*$  value showed that yacon saccharides tended to yellow and were a little yellower than the commercial FOS ( $>b^*$ ), but not as yellow than Rosell et al. (2009) study's inulin ( $<b^*$ ).

These data indicated the occurrence of enzymatic browning due to the presence of polyphenoloxidase (PPO) and peroxidase (POD) enzymes before the membrane separation processes. Yacon is rich in polyphenolic antioxidants and contains considerable phenolic acid levels, including chlorogenic acid, caffeic acid, and ferulic acid (Takenaka et al. 2003). It is also possible that during the extraction process some Maillard reaction might have taken place and its products could have contributed to the darker color. Lachman et al. (2004) mentioned that the yacon tuberous roots contained 0.3–3.7% protein. De Gennaro et al. (2000) and Huebner et al. (2008)

demonstrated that the sugars produced by partial hydrolysis of fructooligosaccharides could be involved in the Maillard reaction. Shorter chain inulins result, thus in even darker color as it possessed more low molecular weight fructans (Peressini and Sensidoni 2009).

#### Scanning electron microscopy

The microstructure of the yacon saccharides powder and of commercial chicory FOS is shown in Figure 2. The high hygroscopicity of experimentally obtained samples, leading to agglomeration, was easily observed at microscopic images, which showed agglomerates of particles pasted ones with others. After one-week storage of yacon saccharides powder at room temperature, particles were more agglomerated (Fig. 2B) than that removed from the lyophilizer at the same day (Fig. 2A). Spray-dried commercial FOS were formed by the spherical individual particles, with just a few agglomerates (Fig. 2C), indicating smaller water adsorption. Even with magnification of  $\times 1000$ , it was still possible to distinguish the commercial FOS single particles (Fig. 2D).

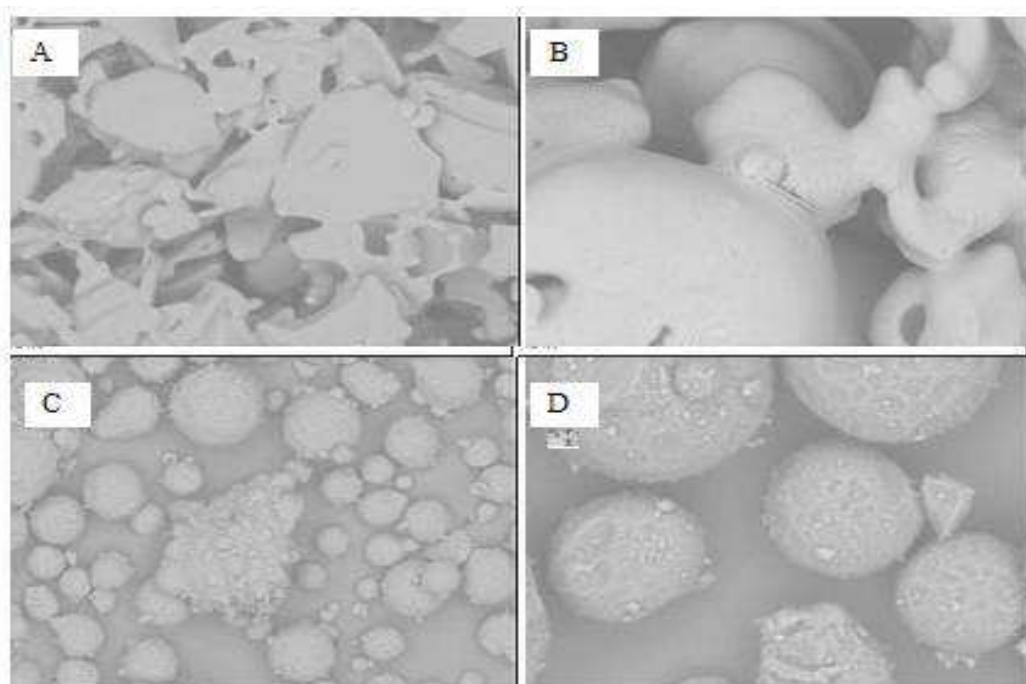

**Figure 2** - Electron microscopy images of yacon saccharides powder (A and B) and of commercial chicory FOS (C and D). Legend: (A) yacon saccharides powder just after freeze-drying - image with magnification of  $\times 250$ ; (B) yacon saccharides powder after 1-week storage - image with magnification of  $\times 250$ ; (C) Commercial chicory FOS - image with magnification of  $\times 250$ ; (D) Commercial chicory FOS - image with magnification of  $\times 1000$ , still allowing single particles observation.

According to Cano-Chauca et al. (2005), the adherence of small particles into bigger ones indicated the absence of crystalline surfaces and was typical of amorphous products.

Lago et al. (2011) evaluated the microscopic structure of the powder obtained from yacon pulp and yacon juice encapsulated with native starch and air dried at 70°C and also observed strong tendency for agglomeration. The obtained images showed that the encapsulated yacon juice powder was formed of starch granules of variable size with mostly smooth surfaces, although some particles had a slightly wrinkled surface. A tendency for the smaller particles to agglomerate around particles of higher diameter could also be seen. Their images of yacon pulp powder revealed the presence of laminar-type structures with 'wrinkles', quite similar to particles of yacon saccharides powder obtained in this work (Fig. 2A).

Toneli et al. (2008) evaluated the effect of humidity on spray-dried chicory inulin microstructure and observed individual spherical particles, similar to images obtained at this experiment for commercial FOS at low humidity levels (until  $a_w$  of 0.31 and equilibrium moisture of 6.26 %) (Fig. 2C and 2D). As humidity was increased, these particles started to agglomerate and, when exposed to an ambient with  $a_w$  higher than 0.52, the powder became a continuous mass, and it was impossible to distinguish individual particles anymore. Ronkart et al. (2006) observed that a commercial spray-dried chicory roots inulin in the powder state was formed by amorphous spherical that agglomerated and formed a continuous mass at  $a_w$  higher than 0.56. Toneli et al. (2008) observed a change in powder color from whitish to yellowish with the increase in humidity. The yacon saccharides powder's color also presented a tendency to yellow, as was indicated by the positive  $b^*$  value of  $1.02 \pm 0.03$ .

The differences observed in the yacon saccharides and commercial chicory FOS could also be related to the drying method. A study undertaken by Haque and Roos (2006) has shown that the spray-dried and freeze-dried lactose and lactose/protein mixtures had different physical structures, thermal transitions and time-dependent lactose crystallization behavior. Spray-dried materials were round shaped particles, but freeze-dried materials resembled broken glass, or had a flake-like structure. These features could be correlated to the SEM images obtained in this work, which

showed spray-dried commercial FOS as spherical particles (Fig. 2C and 2D), while freeze-dried yacon FOS, even agglomerated, looked more angular (Fig. 2A). Ahmed et al. (2005) during microscopic examination of freeze-dried samples, observed the layers of needle-like void spaces previously occupied by the ice crystals formed during the freezing before drying.

### Energy-dispersive X-ray spectroscopy

The elemental atomic qualitative composition for the experimentally obtained yacon saccharides powder and commercial chicory FOS is shown in Table 1. The commercial FOS were mainly composed of carbon and oxygen, with the traces of silicon and aluminum, while experimental yacon FOS, besides carbon and oxygen, contained the traces of many other elements. These components present at experimental FOS sample probably had origin in yacon roots, which contained 180-334 mg/100g fresh roots of potassium and 21-309 mg/100g fresh roots of phosphorous (Lachman et al. 2003; Ojansivu et al. 2011). Traces of sodium and sulfur could be the residues of the sodium metabisulphite ( $\text{Na}_2\text{S}_2\text{O}_5$ ) solution where yacon roots were immersed for avoiding the enzymatic browning of the juice.

The non-negligible potassium content of the yacon saccharides could also have influenced the powder water sorption, in addition to the hygroscopic behavior of reducing sugars. There are reports on the hygroscopic behavior of potassium salts, which possess very rapid moisture sorption rates, reaching the equilibrium in less 10 min when exposed to 33, 52, or 75% relative humidity (Morris et al. 1994). Omar and Roos (2007) studied the water sorption behavior of the freeze-dried lactose-salt mixtures and observed that the amount of water sorbed by the lactose:KCl mixtures at a 9:1 ratio was somewhat higher than that of pure lactose at 11.6–44.0% relative vapor pressure. Imtiaz-U-Islam and Langrish (2008) evaluating the effect of the KCl salt content on the water sorption and microstructure of spray-dried lactose, observed that the powder particle agglomeration seemed more noticeable in the lactose:KCl mixtures at 5:1 and 5:2 ratios. In SEM micrographs, the same authors noticed that, while pure lactose were formed by the spherical particles with smooth surface, lactose:KCl samples had rough surfaces with sharp peaks, indicating that the salt crystals were covered by lactose. These results showed that

KCl slightly bound with lactose, producing amorphous products after spray drying.

**Table 1** - Atomic composition (weight %) obtained by energy-dispersive X-ray spectroscopy (EDS) in experimental yacon saccharides powder and commercial chicory FOS

Atomic element	Weight (%)					
	Experimental yacon saccharides			Commercial chicory FOS		
Carbon	50.337	±	0.320	64.517	±	0.214
Oxygen	46.299	±	0.307	35.345	±	0.214
Sodium	0.186	±	0.023	-	-	-
Magnesium	0.166	±	0.017	-	-	-
Silicon	0.104	±	0.013	0.086	±	0.014
Phosphorus	0.218	±	0.016	-	-	-
Sulfur	0.261	±	0.016	-	-	-
Chlorine	0.287	±	0.017	-	-	-
Potassium	2.140	±	0.031	-	-	-
Aluminum	-	-	-	0.053	±	0.013

### X-ray diffraction

X-ray diffractograms of the commercial chicory FOS are shown in Figure 3. Commercial FOS presented a broad halo pattern with the absence of peaks, characteristic of amorphous form (Kawai et al. 2011). Yacon saccharides diffractograms also did not present any peaks, indicating its amorphous characteristics, but sample high hygroscopicity and formation of a rigid continuous mass might have hindered a trustable X-ray analysis. These results were in accordance with Kawai et al. (2011) study, who observed that two samples of low molecular weight inulin, with degree of polymerization (DP) of 7 and 13, were amorphous, while high molecular weight inulin (DP=27) showed some peaks in the X-ray diffractogram, indicating the existence of an ordered structure typical of a semi-crystal state.

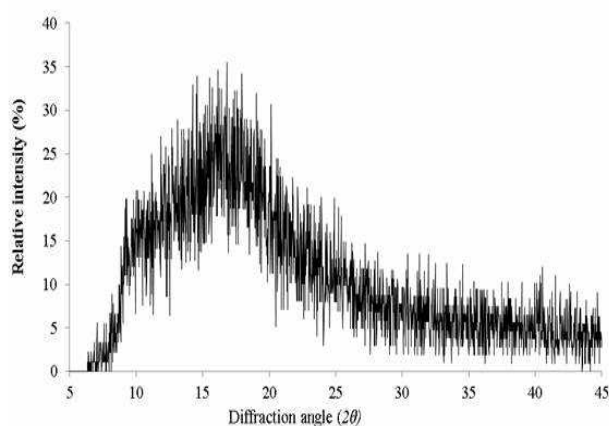

**Figure 3** - X-ray diffractograms of commercial chicory roots FOS.

However, the diffractograms peaks disappeared when this semi-crystalline high molecular weight inulin was dissolved in the water (40% weight) and freeze-dried, indicating that it turned into an amorphous state. Panchev et al. (2011) found that X-ray diffraction patterns of high molecular inulin (DP 28-33) obtained from four varieties of Jerusalem artichoke represented a combination of amorphous and crystalline parts, with degree of crystallinity between 4 and 21%.

Ronkart et al. (2009) reported that the diffractograms of inulin sample extracted from chicory roots (inulin had an average degree of polymerization of 23) and dried by spray-dried presented either a broad halo pattern or diffraction peaks, characteristic of an amorphous, or a semi-crystalline sample, respectively. These samples remained amorphous up to a water content of 15.7 g water/100 g dry inulin; while crystallization occurred between 15.7 and 16.3 g water/100 g dry inulin. In addition, Panchev et al. (2011) obtained inulins from the tubers of four varieties of Jerusalem artichoke (*Helianthus tuberosus* L.). The inulins had a degree of polymerization of around 30 fructose units and the X-ray diffraction patterns of all inulins represented a combination of amorphous and crystalline parts. However, the degree of crystallinity of inulins of three varieties was very low. On the other hand, Goto et al. (1995) reported that the fructooligosaccharides in yacon represented mainly oligosaccharides from trisaccharide to decasaccharide with terminal saccharose.

The amorphous structure of the yacon saccharides powder may explain its high hygroscopicity. A relatively large amount of works have reported the

caking of amorphous products exposed to various water vapor pressures (Meste et al. 2002; Ronkart et al. 2006; Omar and Roos 2007; Ronkart et al. 2009a, b). According to Hartmann and Palzer (2011) crystalline substances preserve their mechanical properties with increasing humidity until they dissolve at a substance-specific critical relative humidity of the surrounding air. Differently, on amorphous water-soluble materials, water does not dissolve particles, but migrates into the amorphous molecular matrix, having a plastifying effect on the structure, with decrease of material viscosity and elasticity (Hartmann and Palzer 2011). Ronkart et al. (2009a), evaluating commercial inulin dissolved in distilled water and spray-dried with air inlet temperature of 120 and 230°C, found that the formation of a continuous mass was observed for the initial amorphous samples stored at 75–94% relative humidity, when particles appeared fused-agglomerated. They also observed that the presence of crystals in the amorphous matrix limited the advanced caking of inulins.

It is known that the amorphous sucrose absorbs higher content of water than the crystalline sucrose when exposed to the same relative humidity. In the crystalline state, the sugar presents a smaller probability of interacting with water molecules due to solid increased organization and rigidity, while on amorphous state, functional groups are more exposed to humidity, allowing this type of interaction (Carlos et al. 2005). The amorphous products' agglomeration process can be explained by the Bhandari and Howes (1999) assumption that low molecular weight carbohydrates with amorphous structure are very hygroscopic and can absorb water in its amorphous regions, locally depressing the glass transition temperature and accelerating the crystallization rate of that particular portion. Tight and orderly molecular packing during the crystallization cannot generally accommodate excess moisture, resulting in the loss of adsorbed water and absorption of this ejected moisture at the surface of neighboring particles, creating inter-particle liquid bridges, leading to 'caking'. Surrounding particles, which absorb the moisture, will also be crystallized and the crystallization can proceed as a chain phenomenon (Bhandari and Howes 1999).

## CONCLUSIONS

The saccharides powder obtained from the yacon roots by membrane purification and freeze-dried, containing 19.75 % FOS, 36.66 % glucose and 43.59 % fructose (w/w), was a granulated whitish powder, with rectangular coordinates  $L^*$ ,  $a^*$  and  $b^*$  of  $76.25 \pm 1.19$ ,  $-1.03 \pm 0.09$  and  $1.02 \pm 0.03$ , respectively. It presented  $a_w$  of 0.284 and was a very hygroscopic product, probably due to the presence of high content of reducing sugars (fructose and glucose). The water adsorption of the experimentally obtained powder was confirmed by the SEM images, which showed intense particles agglomeration. Just after freeze-drying, its particles looked more angular, while a spray-dried commercial FOS evaluated for comparison presented spherical particles, which was related to the drying method. Its amorphous structure, which also might have contributed to the high hygroscopicity, was confirmed by the X-ray diffraction.

## ACKNOWLEDGMENTS

The authors thank the CNPq (National Counsel of Technological and Scientific Development) and the Research Foundation of the State of Rio Grande do Sul (FAPERGS) for financial support.

## REFERENCES

- Ahmed J, Ramaswamy HS, Khan AR. Effect of water activity on glass transitions of date pastes. *J Food Eng.* 2005; 66(2): 253-258.
- Anan'ina N, Andreeva O, Mycots L, Oganessian E. Standardization of inulin extracted from &lt;i>&lt;/i> Dahlia single tubers and some physicochemical properties of inulin. *Pharm Chem J.* 2009; 43(3): 157-159.
- Bhandari BR, Howes T. 1999. Implication of glass transition for the drying and stability of dried foods. *J Food Eng.* 1999; 40: 71-79.
- Cano-Chauca M, Stringheta PC, Ramos AM, Cal-Vidal J. Effect of the carriers on the microstructure of mango powder obtained by spray drying and its functional characterization. *Innovat Food Sci Emerg Tech.* 2005; 6(4): 420-428.
- Carlos LA, Resende JV, Cal-Vidal J. Reduction of freeze-dried powder hygroscopicity by inducing crystallization in model fruit sugar solutions. *Braz J Food Technol.* 2005; 8(2): 163-173.



- Catarino I, Minhalma M, Beal LL, Mateus M, de Pinho MN. Assessment of saccharide fractionation by ultrafiltration and nanofiltration. *J Membr Sci.* 2008; 312(1-2): 34-40.
- Davis E. Functionality of sugars: physicochemical interactions in foods. *Am J Clin Nutr.* 1995; 62(1): 170S-177S.
- De Gennaro S, Birch GG, Parke SA, Stancher B. Studies on the physicochemical properties of inulin and inulin oligomers. *Food Chem.* 2000; 68(2): 179-183.
- Figueira GM, Park KJ, Brod FPR, Honorio SL. Evaluation of desorption isotherms, drying rates and inulin concentration of chicory roots (*Cichorium intybus L.*) with and without enzymatic inactivation. *J Food Eng.* 2004; 63(3): 273-280.
- Figueroa-Gonzalez I, Quijano G, Ramirez G, Cruz-Guerrero A. Probiotics and prebiotics - perspectives and challenges. *J Sci Food Agric.* 2011; 91(8): 1341-1348.
- Franck A. Technological functionality of inulin and oligofructose. *Br J Nutr.* 2002; 87: 287-S291.
- Goto K, Fukai K, Hikida J, Nanjo F, Hara Y. Isolation and structural analysis of oligosaccharides from yacon (*Polymnia sonchifolius*). *Biosci Biotechnol Biochem.* 1995; 59: 2346-2347.
- Goulas AK, Kapasakalidis PG, Sinclair HR, Rastall RA, Grandison AS. Purification of oligosaccharides by nanofiltration. *J Membr Sci.* 2002; 209(1): 321-335.
- Granato D, Branco GF, Nazzaro F, Cruz AG, Faria JAF. Functional Foods and Nondairy Probiotic Food Development: Trends, Concepts, and Products. *Compr Rev Food Sci Food Saf.* 2010; 9(3): 292-302.
- Guigoz Y, Rocha, F, Perruisseau-Carrier G, Rochat I, Schiffrin EJ. Effects of oligosaccharide on the faecal flora and non-specific immune system in elderly people. *Nutr Res.* 2002; 22(1): 13-25.
- Haque MK, Roos YH. Differences in the physical state and thermal behavior of spray-dried and freeze-dried lactose and lactose/protein mixtures. *Innovat Food Sci Emerg Tech.* 2006; 7(1-2): 62-73.
- Hartmann M, Palzer S. Caking of amorphous powders — Material aspects, modelling and applications. *Powder Technol.* 2011; 206(1-2): 112-121.
- Huebner J, Wehling RL, Parkhurst A, Hutkins, RW. Effect of processing conditions on the prebiotic activity of commercial prebiotics. *Int Dairy J.* 2008; 18: 287-293.
- Imtiaz-U-Islam M, Langrish T. The effect of the salt content on the crystallization behaviour and sorption fingerprints of spray-dried lactose. *Food Bioprod Process.* 2008; 86(C4): 304-311.
- Jenkins DJA, Kendall CWC, Vuksan V. Inulin, Oligofructose and Intestinal Function. *J Nutr.* 1999; 129(7): 1431-1433.
- Kamada T, Nakajima M, Nabetani H, Iwamoto S. Pilot-scale study of the purification and concentration of non-digestible saccharides from yacon rootstock using membrane technology. *Food Sci Technol Res.* 2002; 8(2): 172-177.
- Kawai K, Fukami K, Thanatukorn P, Viriyarattanasak C, Kajiwaru K. Effects of moisture content, molecular weight, and crystallinity on the glass transition temperature of inulin. *Carbohydr Polym.* 2011; 83(2): 934-939.
- Kolida S, Gibson GR. Prebiotic Capacity of Inulin-Type Fructans. *J Nutr.* 2007; 137(11): 2503S-2506S.
- Kuhn RC, Maugeri Filho F, Silva V, Palacio L, Hernandez A, Pradanos P. Mass transfer and transport during purification of fructooligosaccharides by nanofiltration. *J Membr Sci.* 2010; 365(1-2): 356-365.
- Lachman J, Fernandez EC, Orsak M. Yacon *Smallanthus sonchifolia* (Poepp. et Endl.) H. Robinson chemical composition and use - a review. *Plant Soil Environ.* 2003; 49(6): 283-290.
- Lachman J, Havrland B, Fernandez EC, Dudjak J. Saccharides of yacon *Smallanthus sonchifolius* (Poepp. et Endl.) H. Robinson tubers and rhizomes and factors affecting their content. *Plant Soil Environ.* 2004; 50(9): 383-390.
- Lago C, Bernstein A, Brandelli A, Noreña C. Characterization of Powdered Yacon (*Smallanthus sonchifolius*) Juice and Pulp. *Food Bioprocess Tech.* 2011; 4: 1-9.
- Lingyun W, Jianhua W, Xiaodong Z, Da T, Yalin Y, Chenggang C, Tianhua F, Fan Z. Studies on the extracting technical conditions of inulin from Jerusalem artichoke tubers. *J Food Eng.* 2007; 79(3): 1087-1093.
- Maia MCA, Cal-Vidal J. Kinetics of water uptake by citrus juices in powder form. *Int J Food Sci Technol.* 1994; 29(2): 137-141.
- Menne E. Guggenbuhl N. Fn-type Chicory Inulin Hydrolysate Has a Prebiotic Effect in Humans. *J Nutr.* 2000; 130(5): 1197-1199.
- Meste ML, Champion D, Roudaut G, Blond G, Simatos D. Glass Transition and Food Technology: A Critical Appraisal. *J Food Sci.* 2002; 67(7): 2444-2458.
- Minhalma M, Beal LL, Catarino I, Mateus M, Norberta de Pinho M. Optimization of saccharide fractionation using nanofiltration/ultrafiltration. *Desalination.* 2006; 199(1-3): 337-339.
- Morris KR, Fakes MG, Thakur AB, Newman AW, Singh AK, Venit JJ, Spagnuolo CJ, Serajuddin ATM. An integrated approach to the selection of optimal salt form for a new drug candidate. *Int J Pharm.* 1994; 105(3): 209-217.
- Murrieta-Pazos I, Gaiani C, Galet L, Scher J. Composition gradient from surface to core in dairy powders: Agglomeration effect. *Food Hydrocolloid.* 2012; 26(1): 149-158.

- Nabarlatz D, Torras, C, Garcia-Valls R, Montané D. Purification of xylo-oligosaccharides from almond shells by ultrafiltration. *Sep Purif Technol.* 2007; 53(3): 235-243.
- Ojansivu I, Ferreira CL, Salminen S. Yacon, a new source of prebiotic oligosaccharides with a history of safe use. *Trends Food Sci Technol.* 2011; 22(1): 40-46.
- Omar AME, Roos, YH. Water sorption and time-dependent crystallization behaviour of freeze-dried lactose-salt mixtures. *LWT-Food Sci Technol.* 2007; 40(3): 520-528.
- Padilha VM, Rolim PM, Salgado SM, Livera AVS, Oliveira MGD. Avaliação do tempo de secagem e da atividade de óxido-redutases de yacon (*Smallanthus sonchifolius*) sob tratamento químico. *Cienc Rural.* 2009; 39: 2178-2184.
- Panchev I, Delchev N, Kovacheva D, Slavov A. Physicochemical characteristics of inulins obtained from Jerusalem artichoke (*Helianthus tuberosus L.*). *Eur Food Res Technol.* 2011; 233(5): 889-896.
- Peressini D, Sensidoni A. Effect of soluble dietary fibre addition on rheological and breadmaking properties of wheat doughs. *J Cereal Sci.* 2009; 49: 190-201.
- Rao V.A. The prebiotic properties of oligofructose at low intake levels. *Nutr Res.* 2001; 21(6): 843-848.
- Roberfroid MB. Inulin-Type Fructans: Functional Food Ingredients. *J Nutr.* 2007; 137(11): 2493S-2502S.
- Ronkart S, Blecker C, Fougnyes C, Van Herck JC, Wouters J, Paquot M. Determination of physical changes of inulin related to sorption isotherms: An X-ray diffraction, modulated differential scanning calorimetry and environmental scanning electron microscopy study. *Carbohydr Polym.* 2006; 63(2): 210-217.
- Ronkart S, Deroanne C, Paquot M, Fougnyes C, Lambrechts JC, Blecker C. Characterization of the Physical State of Spray-Dried Inulin. *Food Biophys.* 2007; 2(2): 83-92.
- Ronkart SN, Paquot M, Blecker CS, Fougnyes C, Doran L, Lambrechts JC, Norberg B, Deroanne, C. Impact of the Crystallinity on the Physical Properties of Inulin during Water Sorption. *Food Biophys.* 2009a; 4(1): 49-58.
- Ronkart SN, Paquot M, Fougnyes C, Deroanne C, Blecker CS. Effect of water uptake on amorphous inulin properties. *Food Hydrocolloid.* 2009b; 23(3): 922-927.
- Rosell CM, Santos E, Collar C. Physico-chemical properties of commercial fibres from different sources: A comparative approach. *Food Res Int.* 2009; 42(1): 176-184.
- Scher CF, De Oliveira Rios A, Noreña CPZ. Hot air drying of yacon (*Smallanthus sonchifolius*) and its effect on sugar concentrations. *Int J Food Sci Technol.* 2009; 44(11): 2169-2175.
- Siró I, Kápolna E, Kápolna B, Lugasi A. Functional food. product development, marketing and consumer acceptance—A review. *Appetite.* 2008; 51(3): 456-467.
- Sjöman E, Mänttari M, Nyström M, Koivikko H, Heikkilä H. Separation of xylose from glucose by nanofiltration from concentrated monosaccharide solutions. *J Membr Sci.* 2007; 292(1-2): 106-115.
- Takenaka, M, Yan, X, Ono H, Yoshida M., Nagata T., Nakanishi, T. Caffeic Acid Derivatives in the Roots of Yacon (*Smallanthus sonchifolius*). *J Agric Food Chem.* 2003; 51(3): 793-796.
- Toneli JTCL, Mürr FEX, Martinelli P, Dal Fabbro IM, Park KJ. Optimization of a physical concentration process for inulin. *J Food Eng.* 2007; 80(3): 832-838.
- Toneli JTCL, Park KJ, Mürr FEX, Negreiros AA. Efeito da umidade sobre a microestrutura da inulina em pó. *Ciênc Tecnol Aliment.* 2008; 28: 122-131.
- Tuohy K.M, Kolida S, Lustenberger AM, Gibson GR. The prebiotic effects of biscuits containing partially hydrolysed guar gum and fructo-oligosaccharides - a human volunteer study. *Br J Nutr.* 2001; 86(3): 341-348.
- Veereman G. Pediatric applications of inulin and oligofructose. *J Nutr.* 2007; 137(11): 2585S-2589S.
- Waligora-Dupriet AJ, Campeotto F, Nicolis I, Bonet A, Soulaïnes P, Dupont C, Butel M-J. Effect of oligofructose supplementation on gut microflora and well-being in young children attending a day care centre. *Int J Food Microbiol.* 2007; 113(1): 108-113.
- Wang Y. Prebiotics: Present and future in food science and technology. *Food Res Int.* 2009; 42(1): 8-12.
- Zimeri JE, Kokini JL. The effect of moisture content on the crystallinity and glass transition temperature of inulin. *Carbohydr Polym.* 2002; 48(3): 299-304.
- Zuleta A. Sambucetti, M.E. Inulin determination for food labeling. *J Agric Food Chem.* 2001; 49(10): 4570-4572.

Received: November 12, 2012;

Accepted: November 04, 2013.